



78 riva

OWNER'S MANUAL

Vino

YJ50RN

LIT-11626-14-50

5LY-28199-10

Dear Yamaha ATV Owner: Please Review this IMPORTANT SAFETY CARD before operating your ATV (If card is not attached, call 1-800-344-6418).

Dear New Yamaha ATV Owner:

CONGRATULATIONS ON THE PURCHASE OF YOUR NEW YAMAHA ATV. You have purchased a quality Yamaha product that, with proper use and care, will provide hours of riding pleasure. **BEFORE YOU OPERATE YOUR NEW ATV, Yamaha recommends these important points:**

- READ YOUR OWNER'S MANUAL
- A CHILD UNDER 12 YEARS OLD SHOULD NOT OPERATE AN ATV WITH ENGINE SIZE 70CC OR GREATER
- A CHILD UNDER 16 YEARS OLD SHOULD NOT OPERATE AN ATV WITH ENGINE SIZE GREATER THAN 90CC
- TAKE THE FREE HANDS-ON TRAINING COURSE OFFERED BY YAMAHA — ASK YOUR DEALER FOR DETAILS OR CALL 1-800-447-4700

If you have any questions about these points, **or if you purchased your ATV from an authorized Yamaha dealership and were not informed of the age recommendation for your ATV by the dealership**, please fill out the information below and mail this card to Yamaha **today**.

Name:

ATV Model:

Purchase Date:

_____|_____|_____|
MO. DAY YR.

Address:

Primary I.D. (Engine Number):

_____|_____|_____|_____|_____|_____|_____|_____|

Telephone:

() _____

Dealer Name & Address:

READ CAREFULLY

This is not a warranty card



NO POSTAGE
NECESSARY
IF MAILED
IN THE
UNITED STATES

BUSINESS REPLY MAIL
FIRST CLASS PERMIT NO. 4 CYPRESS, CA

POSTAGE WILL BE PAID BY ADDRESSEE

**YAMAHA MOTOR CORPORATION U.S.A.
P.O. BOX 6555
CYPRESS, CALIFORNIA 90630-9989**

ATTN: SALES ADMINISTRATION

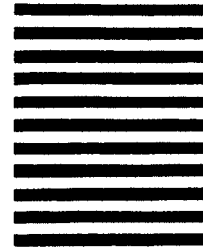

EAU03438

⚠ WARNING

The engine exhaust from this product contains chemicals known to the State of California to cause cancer, birth defects or other reproductive harm.

YAMAHA

LIT-CALIF-65-01

Congratulations on your purchase of the Yamaha YJ50R. This model is the result of Yamaha's vast experience in the production of fine sporting, touring, and pacesetting racing machines. It represents the high degree of craftsmanship and reliability that have made Yamaha a leader in these fields.

This manual will give you an understanding of the operation, inspection, and basic maintenance of this scooter. If you have any questions concerning the operation or maintenance of your scooter, please consult a Yamaha dealer.

IMPORTANT MANUAL INFORMATION

Particularly important information is distinguished in this manual by the following notations:



The Safety Alert Symbol means ATTENTION! BECOME ALERT! YOUR SAFETY IS INVOLVED!

WARNING

Failure to follow WARNING instructions could result in severe injury or death to the scooter operator, a bystander or a person inspecting or repairing the scooter.

CAUTION:

A CAUTION indicates special precautions that must be taken to avoid damage to the scooter.

NOTE:

A NOTE provides key information to make procedures easier or clearer.

NOTE:

- This manual should be considered a permanent part of this scooter and should remain with it even if the scooter is subsequently sold.
 - Yamaha continually seeks advancements in product design and quality. Therefore, while this manual contains the most current product information available at the time of printing, there may be minor discrepancies between your scooter and this manual. If you have any questions concerning this manual, please consult your Yamaha dealer.
-

IMPORTANT MANUAL INFORMATION

EW000000

⚠ WARNING

PLEASE READ THIS MANUAL AND THE “YOU AND YOUR MOTORCYCLE: RIDING TIPS” BOOKLET CAREFULLY AND COMPLETELY BEFORE OPERATING THIS SCOOTER. DO NOT ATTEMPT TO OPERATE THIS SCOOTER UNTIL YOU HAVE ATTAINED ADEQUATE KNOWLEDGE OF ITS CONTROLS AND OPERATING FEATURES AND UNTIL YOU HAVE BEEN TRAINED IN SAFE AND PROPER RIDING TECHNIQUES. REGULAR INSPECTIONS AND CAREFUL MAINTENANCE, ALONG WITH GOOD RIDING SKILLS, WILL ENSURE THAT YOU SAFELY ENJOY THE CAPABILITIES AND THE RELIABILITY OF THIS SCOOTER.

AFFIX DEALER

LABEL HERE

EAU03336

YJ50RN

OWNER'S MANUAL

©2000 by Yamaha Motor Corporation, U.S.A.

1st Edition, November 2000

All rights reserved.

**Any reprinting or unauthorized use
without the written permission of
Yamaha Motor Corporation, U.S.A.
is expressly prohibited.**

Printed in Japan.

P/N LIT-11626-14-50

TABLE OF CONTENTS

1	SAFETY INFORMATION	1-1	Seat.....	3-9
	Safe riding.....	1-1	Helmet holder.....	3-10
	Protective apparel.....	1-2	Storage compartment	3-10
	Modifications	1-3	Carrier	3-11
	Loading and accessories	1-3		
	Gasoline and exhaust gas	1-5	4	PRE-OPERATION CHECKS
	Further safe-riding points	1-6		Pre-operation check list
	Location of important labels	1-7		4-1
2	DESCRIPTION	2-1	5	OPERATION AND IMPORTANT
	Left view	2-1		RIDING POINTS
	Right view	2-2		Starting and warming up a cold
	Controls and instruments	2-3		engine
			
				Starting off.....
			
				Acceleration and deceleration.....
			
				Braking.....
			
				Engine break-in.....
			
				Parking.....
			
3	INSTRUMENT AND CONTROL		6	PERIODIC MAINTENANCE AND
	FUNCTIONS	3-1		MINOR REPAIR
	Main switch/steering lock	3-1		Periodic maintenance and lubrication chart
	Indicator and warning lights	3-2	
	Speedometer unit.....	3-3		Removing and installing the panel
	Fuel gauge	3-4	
	Handlebar switches.....	3-4		Checking the spark plug
	Front brake lever	3-5	
	Rear brake lever	3-5		Final gear oil
	Fuel tank cap	3-6	
	Fuel	3-7		Cleaning the air filter element
	2-stroke engine oil.....	3-8	
	Kickstarter	3-9		Adjusting the carburetor.....
			
				Adjusting the throttle cable

TABLE OF CONTENTS

free play	6-10
Tires	6-10
Adjusting the front and rear brake lever	
free play	6-12
Checking the front and rear brake shoes	6-13
Adjusting the Autolube pump	6-13
Battery	6-14
Lubricating the brake lever	6-16
Replacing the fuse	6-16
Troubleshooting	6-17
Troubleshooting chart	6-18

Riva limited warranty	9-6
Yamaha extended service	9-8

SCOOTER CARE AND

STORAGE	7-1
Care	7-1
Storage	7-4

7

SPECIFICATIONS	8-1
Specification	8-1

8

CONSUMER INFORMATION	9-1
Identification numbers	9-1
Key identification number	9-1

9

Vehicle identification number	9-1
Model label	9-2
Reporting safety defects	9-3
Scooter noise regulation	9-4



SCOOTERS ARE SINGLE TRACK VEHICLES. THEIR SAFE USE AND OPERATION ARE DEPENDENT UPON THE USE OF PROPER RIDING TECHNIQUES AS WELL AS THE EXPERTISE OF THE OPERATOR. EVERY OPERATOR SHOULD KNOW THE FOLLOWING REQUIREMENTS BEFORE RIDING THIS SCOOTER.

HE OR SHE SHOULD:

1. OBTAIN THOROUGH INSTRUCTIONS FROM A COMPETENT SOURCE ON ALL ASPECTS OF SCOOTER OPERATION.
2. OBSERVE THE WARNINGS AND MAINTENANCE REQUIREMENTS IN THE OWNER'S MANUAL.
3. OBTAIN QUALIFIED TRAINING IN SAFE AND PROPER RIDING TECHNIQUES.
4. OBTAIN PROFESSIONAL TECHNICAL SERVICE AS INDICATED BY THE OWNER'S MANUAL AND/OR WHEN MADE NECESSARY BY MECHANICAL CONDITIONS.

Safe riding

1. Always make pre-operation checks. Careful checks may help prevent an accident.
2. This scooter is designed to carry the operator only. No passengers.
3. The failure of motorists to detect and recognize scooters in traffic is the predominating cause of automobile/scooter accidents. Many accidents have been caused by an automobile driver who did not see the scooter. Making yourself conspicuous appears to be very effective in reducing the chance of this type of accident.

Therefore:

- a. Wear a brightly colored jacket.
- b. Use extra caution when approaching and passing through intersections, since intersections are the most likely places for scooter accidents to occur.
- c. Ride where other motorists can see you. Avoid riding in another motorist's blind spot.



SAFETY INFORMATION

4. Many accidents involve inexperienced operators. In fact, many operators who have been involved in accidents do not even have a current driver's license.
 - a. Make sure that you are qualified and that you only lend your scooter to other qualified operators.
 - b. Know your skills and limits. Staying within your limits may help you to avoid an accident.
 - c. We recommend that you practice riding your scooter where there is no traffic until you have become thoroughly familiar with the scooter and all of its controls.
5. Many accidents have been caused by error of the scooter operator. A typical error made by the operator is veering wide on a turn due to EXCESSIVE SPEED or undercornering (insufficient lean angle for the speed).
 - a. Always obey the speed limit and never travel faster than warranted by road and traffic conditions.
 - b. Always signal before turning or changing lanes. Make sure that other motorists can see you.
6. The posture of the operator is important for proper control. The operator should keep both hands on the handlebar and both feet on the footboard during operation to maintain control of the scooter.
7. Never ride under the influence of alcohol or other drugs.
8. This scooter is designed for on-road use only. It is not suitable for off-road use.

Protective apparel

The majority of fatalities from scooter accidents are the result of head injuries. The use of a safety helmet is the single most critical factor in the prevention or reduction of head injuries.

1. Always wear an approved helmet.
2. Wear a face shield or goggles. Wind in your unprotected eyes could contribute to an impairment of vision that could delay seeing a hazard.



3. The use of a jacket, substantial shoes, trousers, gloves, etc., is effective in preventing or reducing abrasions or lacerations.
4. Never wear loose-fitting clothes, otherwise they could catch on the control levers or wheels and cause injury or an accident.
5. Never touch the engine or exhaust system during or after operation. They become very hot and can cause burns. Always wear protective clothing that covers your legs, ankles, and feet.

Modifications

Modifications made to this scooter not approved by Yamaha, or the removal of original equipment, may render the scooter unsafe for use and may cause severe personal injury. Modifications may also make your scooter illegal to use.

Loading and accessories

Adding accessories or cargo to your scooter can adversely affect stability and handling if the weight distribution of the scooter is changed. To avoid the possibility of an accident, use extreme caution when adding cargo or accessories to your scooter. Use extra care when riding a scooter that has added cargo or accessories. Here are some general guidelines to follow if loading cargo or adding accessories to your scooter:

Loading

The total weight of the operator, accessories and cargo must not exceed the maximum load limit of 75 kg (165 lb). When loading within this weight limit, keep the following in mind:

1. Cargo and accessory weight should be kept as low and close to the scooter as possible. Make sure to distribute the weight as evenly as possible on both sides of the scooter to minimize imbalance or instability.



SAFETY INFORMATION

2. Shifting weights can create a sudden imbalance. Make sure that accessories and cargo are securely attached to the scooter before riding. Check accessory mounts and cargo restraints frequently.
3. Never attach any large or heavy items to the handlebar, front fork, or front fender. Such items can create unstable handling or a slow steering response.

Accessories

Genuine Yamaha accessories have been specifically designed for use on this scooter. Since Yamaha cannot test all other accessories that may be available, you must personally be responsible for the proper selection, installation and use of non-Yamaha accessories. Use extreme caution when selecting and installing any accessories.

Keep the following guidelines in mind, as well as those provided under “Loading” when mounting accessories.

1. Never install accessories or carry cargo that would impair the performance of your scooter. Carefully inspect the accessory before using it to make sure that it does not in any way reduce ground clearance or cornering clearance, limit suspension travel, steering travel or control operation, or obscure lights or reflectors.
 - a. Accessories fitted to the handlebar or the front fork area can create instability due to improper weight distribution or aerodynamic changes. If accessories are added to the handlebar or front fork area, they must be as lightweight as possible and should be kept to a minimum.
 - b. Bulky or large accessories may seriously affect the stability of the scooter due to aerodynamic effects. Wind may attempt to lift the scooter, or the scooter may become unstable in cross winds. These accessories may also cause instability when passing or being passed by large vehicles.



- c. Certain accessories can displace the operator from his or her normal riding position. This improper position limits the freedom of movement of the operator and may limit control ability, therefore, such accessories are not recommended.
2. Use caution when adding electrical accessories. If electrical accessories exceed the capacity of the scooter's electrical system an electric failure could result, which could cause a dangerous loss of lights or engine power.

Gasoline and exhaust gas

1. GASOLINE IS HIGHLY FLAMMABLE:
 - a. Always turn the engine off when refueling.
 - b. Take care not to spill any gasoline on the engine or exhaust system when refueling.
 - c. Never refuel while smoking or in the vicinity of an open flame.
2. Never start the engine or let it run for any length of time in a closed area. The exhaust fumes are poisonous and may cause loss of consciousness and death within a short time. Always operate your scooter in an area that has adequate ventilation.
3. Always turn the engine off before leaving the scooter unattended and remove the key from the main switch. When parking the scooter, note the following:
 - a. The engine and exhaust system may be hot, therefore, park the scooter in a place where pedestrians or children are not likely to touch these hot areas.
 - b. Do not park the scooter on a slope or soft ground, otherwise it may fall over.
 - c. Do not park the scooter near a flammable source (e.g., a kerosene heater, or near an open flame), otherwise it could catch fire.
4. If you should swallow any gasoline, inhale a lot of gasoline vapor, or allow gasoline to get in your eyes, see your doctor immediately. If any gasoline spills on your skin or clothing, immediately wash the affected area with soap and water and change your clothes.



SAFETY INFORMATION

EAU00023

Further safe-riding points

1. Make sure to signal clearly when making turns.

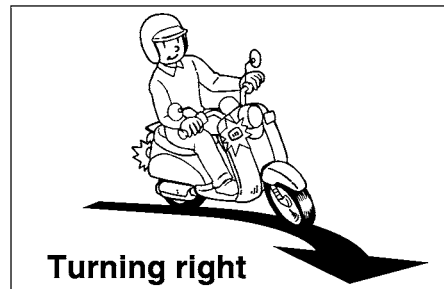
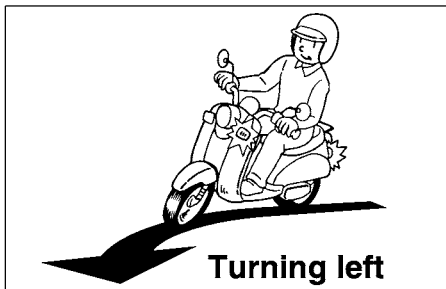

2. Braking can be extremely difficult on a wet road. Avoid hard braking, because the scooter could slide. Apply the brakes slowly when stopping on a wet surface.
3. Slow down as you approach a corner or turn. Once you have completed a turn, accelerate slowly.
4. Be careful when passing parked cars. A driver might not see you and open a door in your path.
5. Railroad crossings, streetcar rails, iron plates on road construction sites, and manhole covers become extremely slippery when wet. Slow down and cross them with caution. Keep the scooter upright, otherwise it could slide out from under you.
6. The brake lining could get wet when you wash the scooter. After washing the scooter, check the brakes before riding.
7. Always wear a helmet, gloves, trousers (tapered around the cuff and ankle so they do not flap), and a bright colored jacket.
8. Do not carry too much luggage on the scooter. An overloaded scooter is unstable. Use a strong cord to secure any luggage to the carriers. A loose load will affect the stability of the scooter and could divert your attention from the road. (See page 1-3 in the "Loading and accessories" section for instructions on carrying a load.)



Location of important labels

Please read the following important labels carefully before operating this scooter.

1

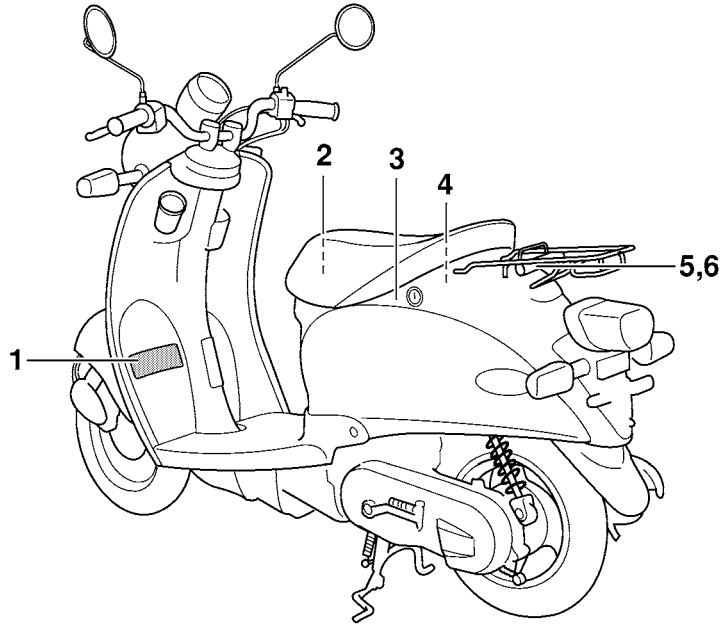



SAFETY INFORMATION

1

⚠ WARNING

- **BEFORE YOU OPERATE THIS VEHICLE, READ THE OWNER'S MANUAL AND ALL LABELS.**
- **NEVER CARRY A PASSENGER.** you increase your risk of losing control if you carry a passenger.
- **ALWAYS WEAR AN APPROVED MOTORCYCLE HELMET,** eye protection, and protective clothing.

3SL-2118K-A0

5

⚠ WARNING

NEVER sit here.

3MX-24875-A0

2

LOAD LIMIT

5 kg {11 lbs}

3LD-24877-A0

6

LOAD LIMIT

3 kg {7 lbs}

3TB-24877-A0

3

⚠ WARNING

Improper loading can cause loss of control.
Read owner's manual for proper loading.

3JJ-28446-A0

4

TIRE INFORMATION

Cold tire normal pressure should be set as follows.

FRONT : 150 kPa,{1.50 kgf/cm²}, 22 psi
REAR : 175 kPa,{1.75 kgf/cm²}, 25 psi

5LY-21688-A0



DESCRIPTION

Left view

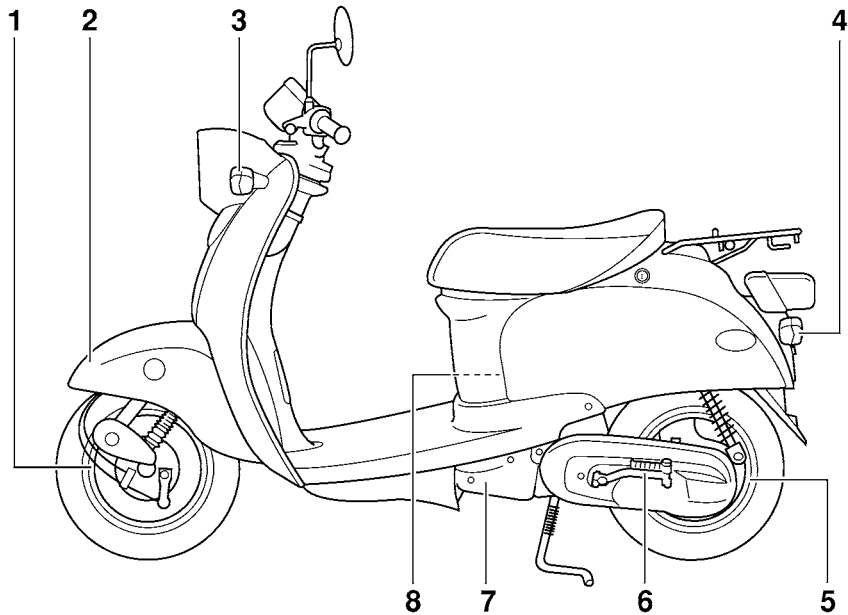

1. Front wheel
2. Front fender
3. Front turn signal light
4. Rear turn signal light
5. Rear wheel

6. Kick starter
7. Air filter element
8. Battery

(page 3-9)
(page 6-8)
(page 6-14)

Right view

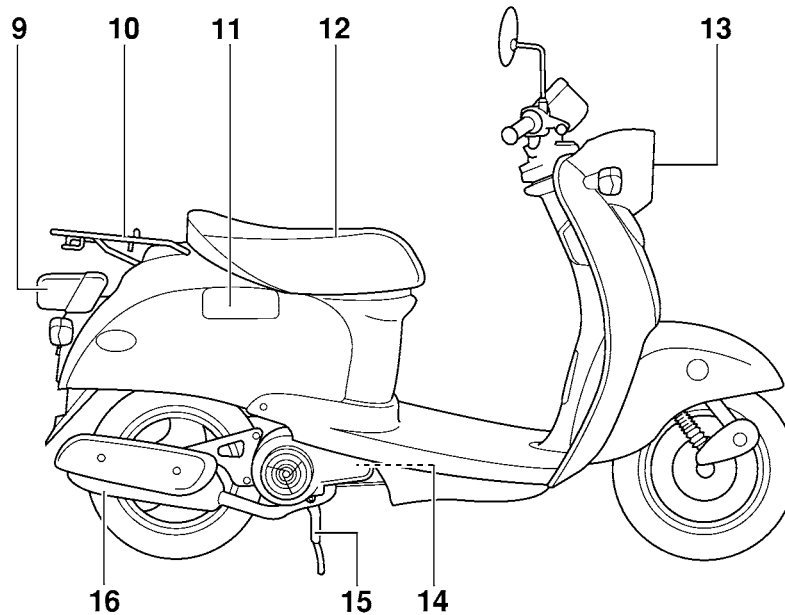

- 9. Tail/brake light
- 10. Carrier (page 3-11)
- 11. 2-stroke engine oil tank cap cover (page 3-8)
- 12. Seat (page 3-9)
- 13. Headlight

- 14. Spark plug
- 15. Centerstand
- 16. Muffler

(page 6-5)

DESCRIPTION

Controls and instruments

2

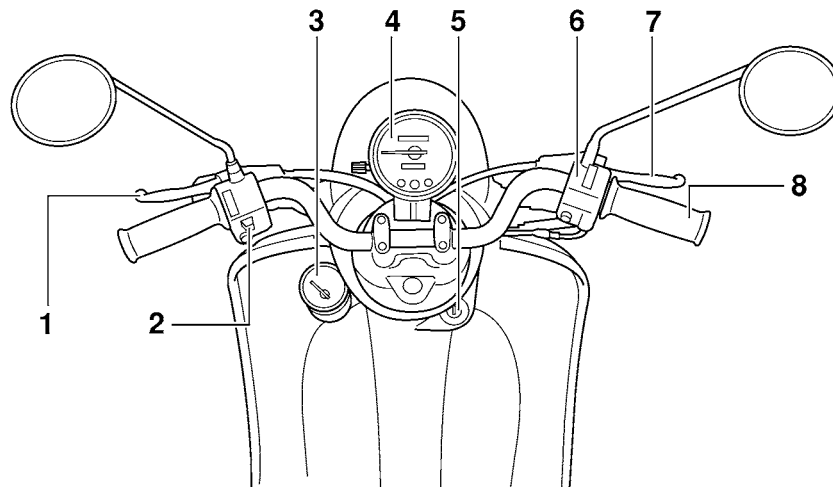

- 1. Rear brake lever
- 2. Left handlebar switches
- 3. Fuel gauge
- 4. Speedometer unit
- 5. Main switch/steering lock

(page 3-5)
(page 3-4)
(page 3-4)
(page 3-3)
(page 3-1)

- 6. Right handlebar switches
- 7. Front brake lever
- 8. Throttle grip

(page 3-4)
(page 3-5)
(page 6-10)

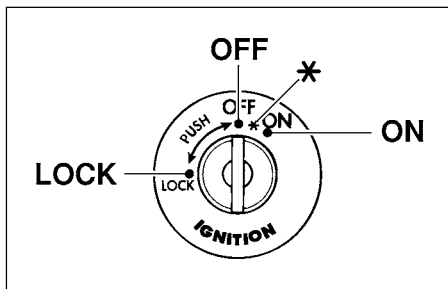

EAU00029

Main switch/steering lock

The main switch/steering lock controls the ignition and lighting systems, and is used to lock the steering. The various positions are described below.

EAU00034

ON

All electrical circuits are supplied with power, the taillight comes on, and the engine can be started. The key cannot be removed.

NOTE: _____

The headlight and meter lighting come on automatically when the engine is started.

EAU00038

OFF

All electrical systems are off. The key can be removed.

EAU02954

*

The engine oil level warning light should come on. See page 3-2 for an explanation of the engine oil level warning light.

EAU00040

LOCK

The steering is locked, and all electrical systems are off. The key can be removed.

INSTRUMENT AND CONTROL FUNCTIONS

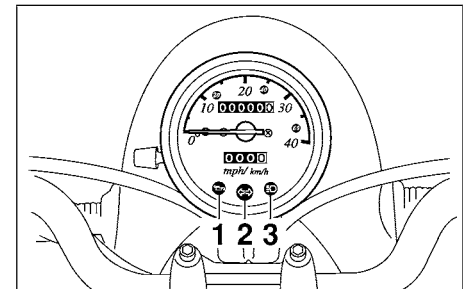
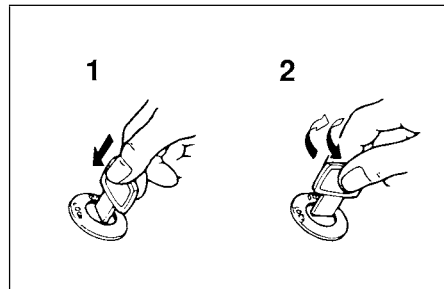
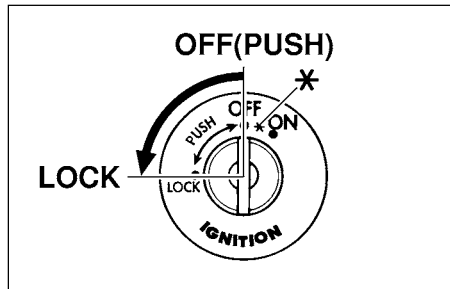

1. 2-stroke oil level warning light “”
2. Turn signal indicator light “”
3. High beam indicator light “”

EAU03034

To lock the steering

1. Turn the handlebars all the way to the left.
2. Push the key in from the “OFF” position, and then turn it to “LOCK” while still pushing it.
3. Remove the key.

To unlock the steering

Push the key in, and then turn it to “OFF” while still pushing it.

EW000016

⚠WARNING

Never turn the key to “OFF” or “LOCK” while the scooter is moving, otherwise the electrical systems will be switched off, which may result in loss of control or an accident. Make sure that the scooter is stopped before turning the key to “OFF” or “LOCK”.

Indicator and warning lights

EAU03990

2-stroke oil level warning light “”

The warning light comes on when the key is in the “*” position or when the engine oil level in the 2-stroke engine oil tank is low during operation. If the warning light comes on during operation, stop immediately and fill the oil tank with Yamalube 2 or an equivalent 2-stroke engine oil. The warning light should go off after the 2-stroke engine oil tank has been refilled.

INSTRUMENT AND CONTROL FUNCTIONS

NOTE:

If the warning light does not come on when the key is in the “*” position or does not go off after the 2-stroke engine oil tank has been refilled, have a Yamaha dealer check the electrical circuit.

CAUTION:

Do not operate the scooter until you know that the engine oil level is sufficient.

The electrical circuit of the warning light can be checked according to the following procedure.

1. Turn the key to “*” from the “OFF” position.
2. If the warning light does not come on, have a Yamaha dealer check the electrical circuit.

Turn signal indicator light “↔”

This indicator light flashes when the turn signal switch is pushed to the left or right.

High beam indicator light “≡”

This indicator light comes on when the high beam of the headlight is switched on.

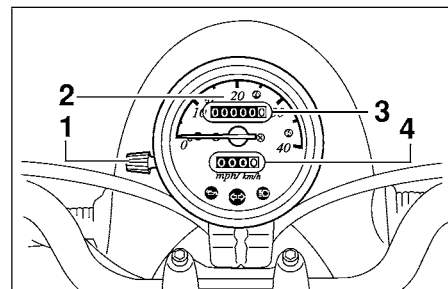

1. Tripmeter reset knob
2. Speedometer
3. Odometer
4. Tripmeter

Speedometer unit

The speedometer unit is equipped with a speedometer, an odometer and a tripmeter. The speedometer shows riding speed. The odometer shows the total distance traveled. The tripmeter shows the distance traveled since it was last set to zero with the reset knob. The tripmeter can be used to estimate the distance that can be traveled with a full tank of fuel. This information will enable you to plan future fuel stops.

INSTRUMENT AND CONTROL FUNCTIONS

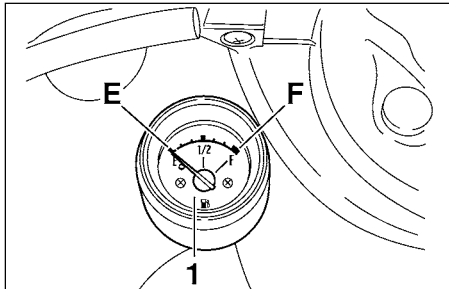

1. Fuel gauge

EAU00113

Fuel gauge

The fuel gauge indicates the amount of fuel in the fuel tank. The needle moves towards “E” (Empty) as the fuel level decreases. When the needle reaches “E”, refuel as soon as possible.

NOTE:

Do not allow the fuel tank to empty itself completely.

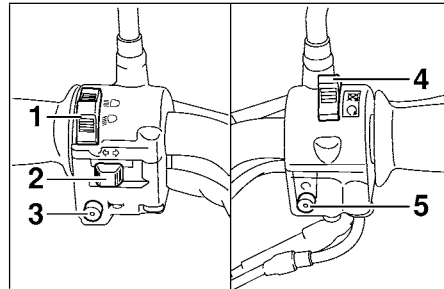

1. Dimmer switch “ ”
2. Turn signal switch “ ”
3. Horn switch “ ”
4. Engine stop switch “ ”
5. Start switch “ ”

EAU00118

Handlebar switches

EAU03888

Dimmer switch “ ”

Set this switch to “ ” for the high beam and to “ ” for the low beam.

EAU03889

Turn signal switch “ ”

To signal a right-hand turn, push this switch to “ ”. To signal a left-hand turn, push this switch to “ ”. When released, the switch returns to the center position. To cancel the turn signal lights, push the switch in after it has returned to the center position.

EAU00129

Horn switch “ ”

Press this switch to sound the horn.

EAU03890

Engine stop switch “ ”

Set this switch to “ ” before starting the engine. Set this switch to “ ” to stop the engine in case of an emergency, such as when the scooter overturns or when the throttle cable is stuck.

INSTRUMENT AND CONTROL FUNCTIONS

Start switch “”

Push this switch to crank the engine with the starter.

EAU00143

CAUTION:

See page 5-1 for starting instructions prior to starting the engine.

EC006005

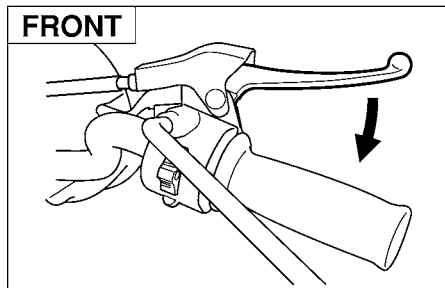

EAU03882

Front brake lever

The front brake lever is located on the right handlebar grip. To apply the front brake, pull this lever toward the handlebar grip.

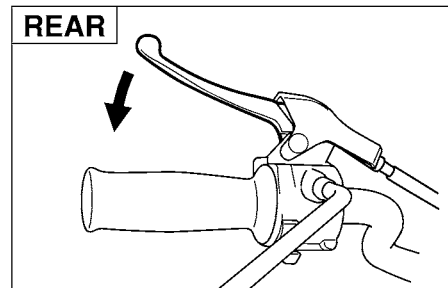

EAU00163

Rear brake lever

The rear brake lever is located on the left handlebar grip. To apply the rear brake, pull this lever toward the handlebar grip.

INSTRUMENT AND CONTROL FUNCTIONS

EW000024

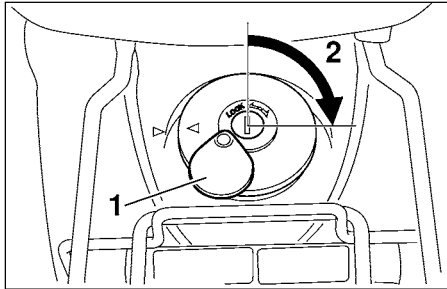

1. Fuel tank cap lock cover
2. Unlock.

EAU03447

Fuel tank cap

To remove the fuel tank cap

Slide the lock cover open, insert the key into the lock, and then turn it 1/4 turn clockwise. The lock will be released and the fuel tank cap can be removed.

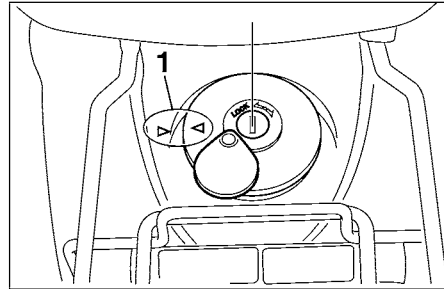

1. Match marks

To install the fuel tank cap

1. Insert the fuel tank cap into the tank opening with the key inserted in the lock and with the marks on the cap and tank aligned.
2. Turn the key counterclockwise to the original position, remove it, and then close the lock cover.

NOTE: _____

The fuel tank cap cannot be installed unless the key is in the lock. In addition, the key cannot be removed if the cap is not properly installed and locked.

⚠ WARNING

Make sure that the fuel tank cap is properly installed before riding.

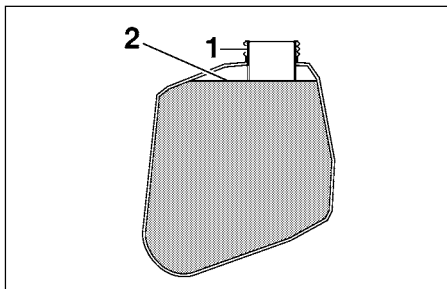

1. Fuel tank filler tube
2. Fuel level

EAU03753

Fuel

Make sure that there is sufficient fuel in the tank. Fill the fuel tank to the bottom of the filler tube as shown.

EW000130

⚠ WARNING

- Do not overfill the fuel tank, otherwise it may overflow when the fuel warms up and expands.
- Avoid spilling fuel on the hot engine.

EAU00185

CAUTION:

Immediately wipe off spilled fuel with a clean, dry, soft cloth, since fuel may deteriorate painted surfaces or plastic parts.

EAU03448

Recommended fuel:
UNLEADED FUEL

Fuel tank capacity:

Total amount:

6 L

(1.32 Imp gal, 1.59 US gal)

Your Yamaha engine has been designed to use regular unleaded gasoline with a pump octane number [(R+M)/2] of 86 or higher, or a research octane number of 91 or higher. If knocking (or pinging) occurs, use a gasoline of a different brand or premium unleaded fuel. Use of unleaded fuel will extend spark plug life and reduce maintenance costs. If unleaded gasoline is not available, then leaded regular gasoline can be used.

Gasohol

There are two types of gasohol: gasohol containing ethanol and that containing methanol. Gasohol containing ethanol can be used if the ethanol content does not exceed 10%. Gasohol containing methanol is not recommended by Yamaha because it can cause damage to the fuel system or vehicle performance problems.

INSTRUMENT AND CONTROL FUNCTIONS

EAU03969

2-stroke engine oil

Make sure that there is sufficient oil in the 2-stroke engine oil tank. If necessary, add the recommended 2-stroke engine oil as follows.

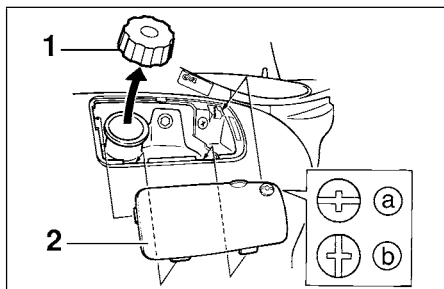

1. 2-stroke engine oil tank cap
 2. 2-stroke engine oil tank cap cover
 - a. Unlock.
 - b. Lock.
1. Remove the 2-stroke engine oil tank cap cover as shown.
 2. Remove the 2-stroke engine oil tank cap and add the recommended oil.
 3. Install the 2-stroke engine oil tank cap and tank cap cover.

NOTE: _____

Make sure that the 2-stroke engine oil tank cap is properly installed.

Recommended oil:

See page 8-1.

Oil quantity:

Total amount:

1.3 L

(1.14 Imp qt, 1.37 US qt)

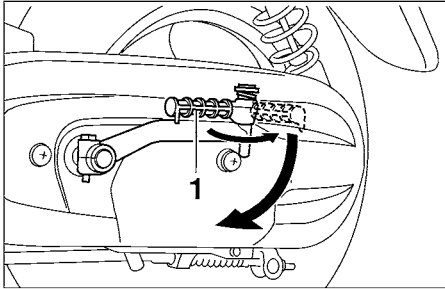

1. Kickstarter

EAU00214

Kickstarter

To start the engine, fold out the kickstarter lever, move it down lightly with your foot until the gears engage, and then push it down smoothly but forcefully.

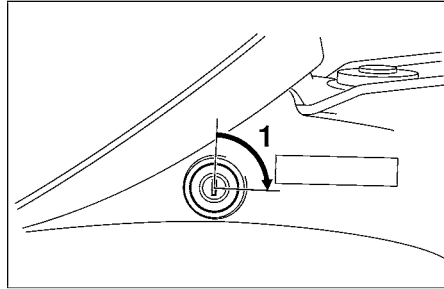

1. Open.

EAU02978

Seat

To open the seat

1. Insert the key in the lock, and then turn it as shown.
2. Fold the seat up.

To close the seat

1. Fold the seat down, and then push it down to lock it in place.
2. Remove the key.

NOTE: _____

Make sure that the seat is properly secured before riding.

INSTRUMENT AND CONTROL FUNCTIONS

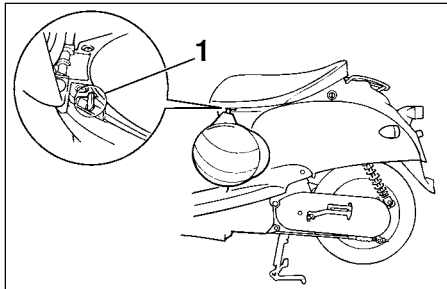

1. Helmet holder

EAU00262

Helmet holder

The helmet holder is located under the seat.

To secure a helmet to the helmet holder

1. Open the seat. (See page 3-9 for opening procedures.)
2. Attach the helmet to the helmet holder, and then securely close the seat.

EW000030

⚠WARNING

Never ride with a helmet attached to the helmet holder, since the helmet may hit objects, causing loss of control and possibly an accident.

To release the helmet from the helmet holder

Open the seat, remove the helmet from the helmet holder, and then close the seat.

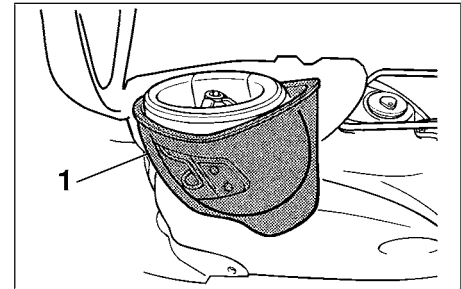

1. Storage compartment

EAU03450

Storage compartment

There is a storage compartment under the seat. (See page 3-9 for seat opening and closing procedures.)

EWA00005

⚠WARNING

- Do not exceed the load limit of 5 kg (11 lb) for the storage compartment.
- Do not exceed the maximum load of 75 kg (165 lb) for the vehicle.

INSTRUMENT AND CONTROL FUNCTIONS

EC000010

CAUTION:

Keep the following points in mind when using the storage compartment.

- Since the storage compartment accumulates heat when exposed to the sun, do not store anything susceptible to heat inside it.
- To avoid humidity from spreading through the storage compartment, wrap wet articles in a plastic bag before storing them in the compartment.
- Since the storage compartment may get wet while the scooter is being washed, wrap any articles stored in the compartment in a plastic bag.
- Do not keep anything valuable or breakable in the storage compartment.

To store a helmet in the storage compartment, place the helmet upside-down with the front facing forward.

NOTE:

- Some helmets cannot be stored in the storage compartment because of their size or shape.
- Do not leave your scooter unattended with the seat open.

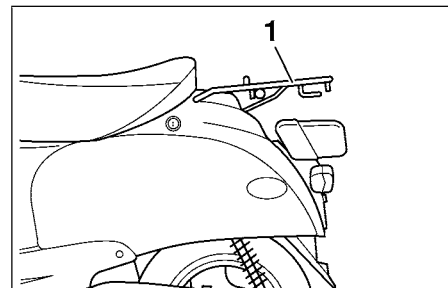

1. Carrier

EAU00320

Carrier

EW000332

⚠ WARNING

- Do not exceed the load limit of 3 kg (7 lb) for the carrier.
- Do not exceed the maximum load of 75 kg (165 lb) for the vehicle.

PRE-OPERATION CHECKS

The condition of a vehicle is the owner's responsibility. Vital components can start to deteriorate quickly and unexpectedly, even if the vehicle remains unused (for example, as a result of exposure to the elements). Any damage, fluid leakage or loss of tire air pressure could have serious consequences. Therefore, it is very important, in addition to a thorough visual inspection, to check the following points before each ride.

EAU03439

Pre-operation check list

ITEM	CHECKS	PAGE
Fuel	<ul style="list-style-type: none"> • Check fuel level in fuel tank. • Refuel if necessary. • Check fuel line for leakage. 	3-6-3-7
Two-stroke engine oil	<ul style="list-style-type: none"> • Check oil level in oil tank. • If necessary, add recommended oil to specified level. • Check vehicle for oil leakage. 	3-8
Final gear oil	<ul style="list-style-type: none"> • Check oil level in final gear oil case. • If necessary, add recommended oil to specified level. 	6-7
Front brake	<ul style="list-style-type: none"> • Check operation. • Lubricate cable if necessary. • Check lever free play. • Adjust if necessary. 	3-5, 6-12-6-13, 6-16
Rear brake	<ul style="list-style-type: none"> • Check operation. • Lubricate cable if necessary. • Check lever free play. • Adjust if necessary. 	3-5, 6-12-6-13, 6-16
Throttle grip	<ul style="list-style-type: none"> • Make sure that operation is smooth. • Lubricate throttle grip, housing and cables if necessary. • Check free play. • If necessary, have Yamaha dealer make adjustment. 	6-10

PRE-OPERATION CHECKS

ITEM	CHECKS	PAGE
Wheels and tires	<ul style="list-style-type: none"> • Check for damage. • Check tire condition and tread depth. • Check air pressure. • Correct if necessary. 	6-10–6-12
Brake levers	<ul style="list-style-type: none"> • Make sure that operation is smooth. • Lubricate lever pivoting points if necessary. 	3-5, 6-12–6-13, 6-16
Centerstand	<ul style="list-style-type: none"> • Make sure that operation is smooth. • Lubricate pivot if necessary. 	—
Chassis fasteners	<ul style="list-style-type: none"> • Make sure that all nuts, bolts and screws are properly tightened. • Tighten if necessary. 	—
Instruments, lights, signals and switches	<ul style="list-style-type: none"> • Check operation. • Correct if necessary. 	3-1–3-5

NOTE:

Pre-operation checks should be made each time the scooter is used. Such an inspection can be accomplished in a very short time; and the added safety it assures is more than worth the time involved.

⚠ WARNING

If any item in the Pre-operation check list is not working properly, have it inspected and repaired before operating the scooter.

EWA00033

OPERATION AND IMPORTANT RIDING POINTS

EAU01118

⚠️ WARNING

- Become thoroughly familiar with all operating controls and their functions before riding. Consult a Yamaha dealer regarding any control or function that you do not thoroughly understand.
- Never start the engine or operate it in a closed area for any length of time. Exhaust fumes are poisonous, and inhaling them can cause loss of consciousness and death within a short time. Always make sure that there is adequate ventilation.
- For safety, always start the engine with the centerstand down.

EAU00376

⚠️ CAUTION:

- Make sure not to store personal items near the air cleaner intake, otherwise air intake will be blocked and performance will suffer.
- Make sure not to put anything near the battery and its terminals, otherwise electrical failure and acid corrosion may result.

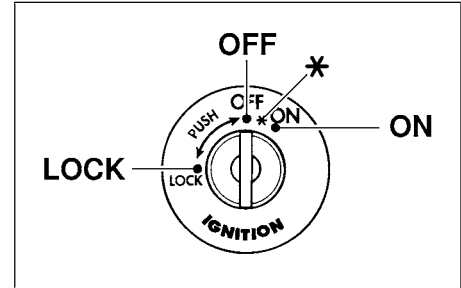

EAU03967

Starting and warming up a cold engine

EC000046

⚠️ CAUTION:

See page 5-4 for engine break-in instructions prior to operating the vehicle for the first time.

1. Set the engine stop switch to "⊙".
2. Turn the key to "✳️", and when the oil level warning light comes on, turn it to "ON".

OPERATION AND IMPORTANT RIDING POINTS

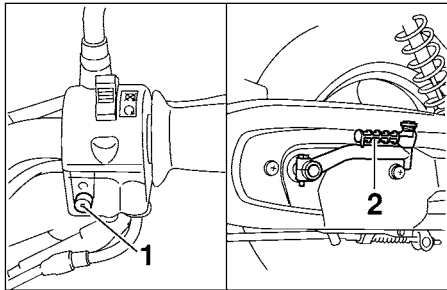

1. Start switch “(S)”
2. Kick starter

EC000045

CAUTION:

If the oil level warning light does not come on, have a Yamaha dealer check the electrical circuit.

3. Close the throttle completely.
4. Start the engine by pushing the start switch or by pushing the kickstarter lever down, while applying the front or rear brake.

NOTE:

If the engine fails to start by pushing the start switch, release the switch, wait a few seconds, and then try again. Each starting attempt should be as short as possible to preserve the battery. Do not crank the engine more than 5 seconds on any one attempt. If the engine does not start with the starter motor, try using the kickstarter.

CAUTION:

For maximum engine life, always warm the engine up before starting off. Never accelerate hard when the engine is cold!

ECA00055

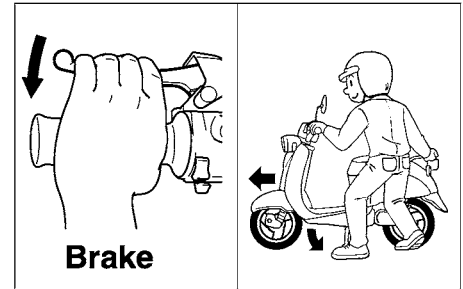

Starting off

NOTE:

Before starting off, allow the engine to warm up.

1. While pulling the rear brake lever with your left hand and holding the grab bar with your right hand, push the scooter off the center-stand.
2. Sit astride the seat, and then adjust the rear view mirrors.
3. Switch the turn signal on.

EAU00433

OPERATION AND IMPORTANT RIDING POINTS

4. Check for oncoming traffic, and then slowly turn the throttle grip (on the right) in order to take off.
5. Switch the turn signal off.

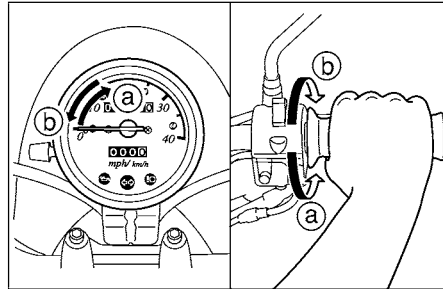

EAU00434

Acceleration and deceleration

The speed can be adjusted by opening and closing the throttle. To increase the speed, turn the throttle grip in direction (a). To reduce the speed, turn the throttle grip in direction (b).

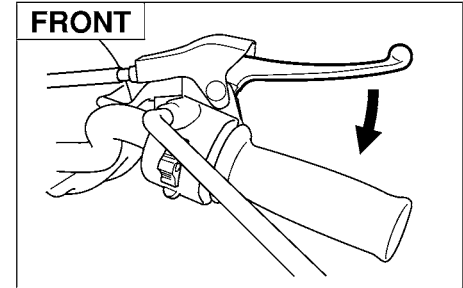

EAU00435

Braking

1. Close the throttle completely.
2. Apply both front and rear brakes simultaneously while gradually increasing the pressure.

EW000057

⚠ WARNING

- **Avoid braking hard or suddenly (especially when leaning over to one side), otherwise the scooter may skid or overturn.**

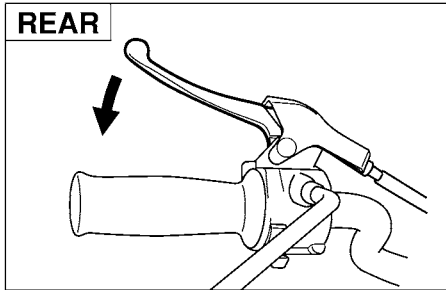

- **Railroad crossings, streetcar rails, iron plates on road construction sites, and manhole covers become extremely slippery when wet. Therefore, slow down when approaching such areas and cross them with caution.**
- **Keep in mind that braking on a wet road is much more difficult.**
- **Ride slowly down a hill, as braking downhill can be very difficult.**

Engine break-in

There is never a more important period in the life of your engine than the period between 0 and 1,000 km (600 mi). For this reason, you should read the following material carefully. Since the engine is brand new, do not put an excessive load on it for the first 1,000 km (600 mi). The various parts in the engine wear and polish themselves to the correct operating clearances. During this period, prolonged full-throttle operation or any condition that might result in engine overheating must be avoided.

0–150 km (0–90 mi)

- Avoid prolonged operation above 1/3 throttle.
- After every hour of operation, stop the engine, and then let it cool for five to ten minutes.
- Vary the engine speed from time to time. Do not operate the engine at one set throttle position.

150–500 km (90–300 mi)

Avoid prolonged operation above 1/2 throttle.

CAUTION:

After 500 km (300 mi) of operation, be sure to replace the final gear oil.

500–1,000 km (300–600 mi)

Avoid prolonged operation above 3/4 throttle.

OPERATION AND IMPORTANT RIDING POINTS

1,000 km (600 mi) and beyond

Avoid prolonged full-throttle operation. Vary the engine speed occasionally.

EC000049

CAUTION:

If any engine trouble should occur during the engine break-in period, immediately have a Yamaha dealer check the vehicle.

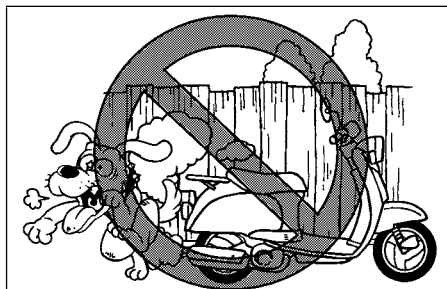

Incorrect.

EAU00461

Parking

When parking, stop the engine, and then remove the key from the main switch.

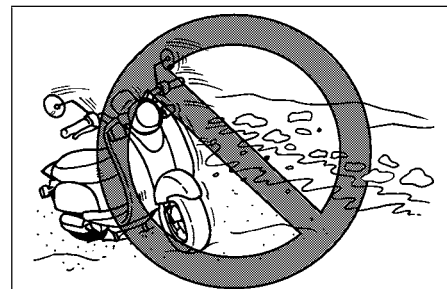

Incorrect.

EW000058

⚠ WARNING

- Since the engine and exhaust system can become very hot, park in a place where pedestrians or children are not likely to touch them.
- Do not park on a slope or on soft ground, otherwise the scooter may overturn.

EC000062

CAUTION:

Never park in an area where there are fire hazards such as grass or other flammable materials.

EAU03453

Safety is an obligation of the owner. Periodic inspection, adjustment and lubrication will keep your vehicle in the safest and most efficient condition possible. The most important points of scooter inspection, adjustment, and lubrication are explained on the following pages.

⚠ WARNING

If you are not familiar with scooter maintenance work, have a Yamaha dealer do it for you.

EW000060

EAU00466

⚠ WARNING

This scooter is designed for use on paved roads only. If this scooter is operated in abnormally dusty, muddy or wet conditions, the air filter element should be cleaned or replaced more frequently, otherwise rapid engine wear may result. Consult a Yamaha dealer for proper maintenance intervals.

PERIODIC MAINTENANCE AND MINOR REPAIR

EAU00473

Periodic maintenance and lubrication chart

NO.	ITEM	ROUTINE	BREAK-IN 300 mi (500 KM)	EVERY	
				2,000 mi (3,000 km) or 6 months	4,000 mi (6,000 km) or 12 months
1	Spark plug	<ul style="list-style-type: none"> • Check condition. • Clean or replace if necessary. 	√	√	√
2	Air filter element	<ul style="list-style-type: none"> • Clean. • Replace if necessary. 		√	√
3 *	Carburetor	<ul style="list-style-type: none"> • Check idle speed. • Adjust if necessary. 	√		√
4 *	Fuel line	<ul style="list-style-type: none"> • Check fuel hose and vacuum pipe for cracks or damage. • Replace if necessary. 		√	√
5 *	Final gear oil	<ul style="list-style-type: none"> • Check oil leakage. • Correct if necessary. • Replace every 8,000 mi (12,000 km) or 24 months. (Ride scooter a few minutes before draining.) 	REPLACE.	√	√
6 *	Autolube pump	<ul style="list-style-type: none"> • Check operation. • Correct if necessary. • Bleed. 	√		√
7	Brakes	<ul style="list-style-type: none"> • Check operation. • Adjust if necessary. 		√	√
8 *	Wheels	<ul style="list-style-type: none"> • Check damage/runout. • Replace if necessary. 		√	√
9 *	Wheel bearings	<ul style="list-style-type: none"> • Check bearing assembly for looseness/damage. • Replace if damaged. 		√	√
10 *	Steering bearings	<ul style="list-style-type: none"> • Check bearing assembly for looseness. • Correct if necessary. • Moderately repack every 8,000 mi (12,000 km) or 24 months.** 	√	√	√
11 *	Rear shock absorber	<ul style="list-style-type: none"> • Check operation/oil leakage. • Replace if necessary. 		√	√

PERIODIC MAINTENANCE AND MINOR REPAIR

NO.	ITEM	ROUTINE	BREAK-IN 300 mi (500 KM)	EVERY	
				2,000 mi (3,000 km) or 6 months	4,000 mi (6,000 km) or 12 months
12	* V-belt	<ul style="list-style-type: none"> • Check damage and wear. • Replace if necessary. • Replace every 6,000 mi (10,000 km). 			√
13	* Chassis fasteners	<ul style="list-style-type: none"> • Check all chassis fittings and fasteners. • Correct if necessary. 	√	√	√
14	* Control and meter cable	<ul style="list-style-type: none"> • Apply chain lube thoroughly. 	√	√	√
15	* Centerstand	<ul style="list-style-type: none"> • Check operation. • Repair if necessary. 	√	√	√

* Since these items require special tools, data and technical skills, have a Yamaha dealer perform the service.

** Lithium soap base grease.

EAU00479

NOTE:

The air filter needs more frequent service if you are riding in unusually wet or dusty areas.

6

EAU03903

NOTE:

From 6,000 mi (9,000 km) or 18 months, repeat the maintenance intervals starting from 2,000 mi (3,000 km) or 6 months.

PERIODIC MAINTENANCE AND MINOR REPAIR

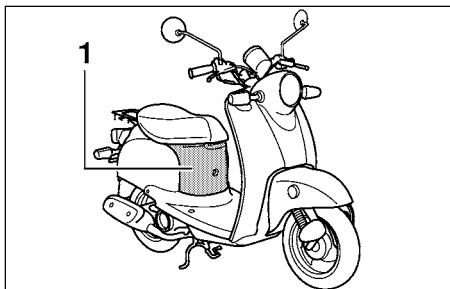

1. Panel A

EAU01122*

Removing and installing the panel

The panels shown above need to be removed to perform some of the maintenance jobs described in this chapter. Refer to this section each time a panel needs to be removed and installed.

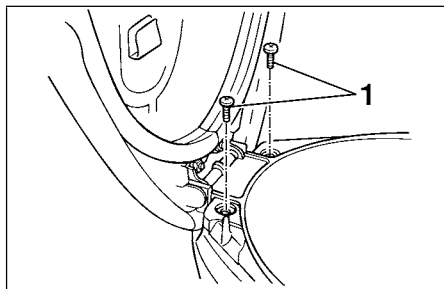

1. Screw (x2)

EAU03971

Panel A

To remove the panel

1. Open the seat. (See page 3-9 for seat opening and closing procedures.)

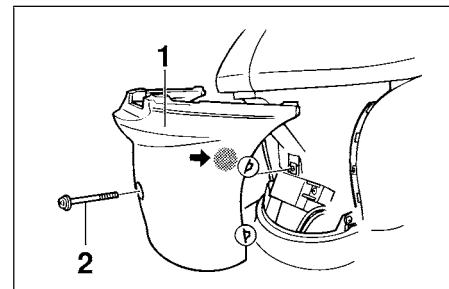

1. Panel "A"
2. Screw

2. Remove the screws, and then pull the panel off as shown.

To install the panel

Place the panel in the original position, and then install the screws.

EAU03972

Checking the spark plug

The spark plug is an important engine component, which is easy to check. Since heat and deposits will cause any spark plug to slowly erode, the spark plug should be removed and checked in accordance with the periodic maintenance and lubrication chart. In addition, the condition of the spark plug can reveal the condition of the engine.

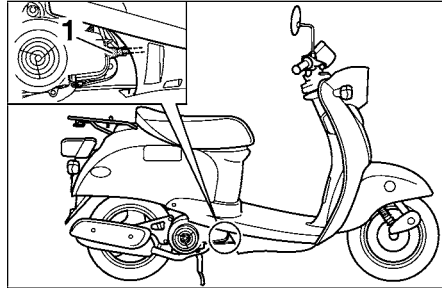

1. Spark plug cap

To remove the spark plug

1. Remove the spark plug cap.

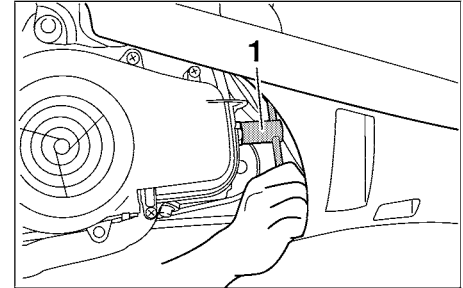

1. Spark plug wrench
2. Remove the spark plug as shown, with a spark plug wrench available at a Yamaha dealer.

PERIODIC MAINTENANCE AND MINOR REPAIR

To check the spark plug

1. Check that the porcelain insulator around the center electrode of the spark plug is a medium-to-light tan (the ideal color when the scooter is ridden normally).

NOTE: _____

If the spark plug shows a distinctly different color, the engine could be defective. Do not attempt to diagnose such problems yourself. Instead, have a Yamaha dealer check the scooter.

2. Check the spark plug for electrode erosion and excessive carbon or other deposits, and replace it if necessary.

Specified spark plug:
BPR7HS (NGK)

To install the spark plug

1. Measure the spark plug gap with a wire thickness gauge and, if necessary, adjust the gap to specification.

Spark plug gap:
0.6–0.7 mm (0.024–0.028 in)

2. Clean the surface of the spark plug gasket and its mating surface, and then wipe off any grime from the spark plug threads.
3. Install the spark plug with the spark plug wrench, and then tighten it to the specified torque.

Tightening torque:
Spark plug:
20 Nm (2.0 m·kg, 14 ft·lb)

NOTE: _____

If a torque wrench is not available when installing a spark plug, a good estimate of the correct torque is 1/4–1/2 turn past finger tight. However, the spark plug should be tightened to the specified torque as soon as possible.

4. Install the spark plug cap.

PERIODIC MAINTENANCE AND MINOR REPAIR

EW000066

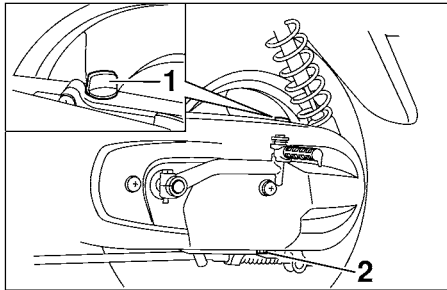

1. Final gear oil filler cap
2. Final gear oil drain bolt

EAU03901

Final gear oil

The final gear case must be checked for oil leakage before each ride. If any leakage is found, have a Yamaha dealer check and repair the scooter. In addition, the final gear oil must be changed as follows at the intervals specified in the periodic maintenance and lubrication chart.

1. Start the engine, warm it up by riding the scooter for several minutes, and then stop the engine.

2. Place the scooter on the centerstand.
3. Place an oil pan under the final gear case to collect the used oil.
4. Remove the oil filler cap and drain bolt to drain the oil from the final gear case.
5. Install the final gear oil drain bolt, and then tighten it to the specified torque.

Tightening torque:

Final gear oil drain bolt:
18 Nm (1.8 m·kgf, 13 ft·lb)

6. Add the specified amount of the recommended final gear oil, and then install and tighten the oil filler cap.

Recommended final gear oil:

See page 8-1.

Oil quantity:

0.11 L (0.1 Imp qt, 0.12 US qt)

⚠ WARNING

- Make sure that no foreign material enters the final gear case.
 - Make sure that no oil gets on the tire or wheel.
7. Check the final gear case for oil leakage. If oil is leaking, check for the cause.

PERIODIC MAINTENANCE AND MINOR REPAIR

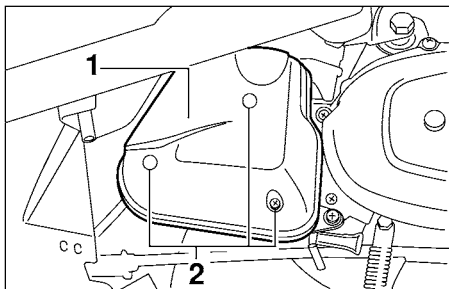

1. Air filter case cover
2. Screw (×3)

EAU03973

Cleaning the air filter element

The air filter element should be cleaned at the intervals specified in the periodic maintenance and lubrication chart. Clean the air filter element more frequently if you are riding in unusually wet or dusty areas.

1. Remove panel A. (See page 6-4 for panel removal and installation procedures.)

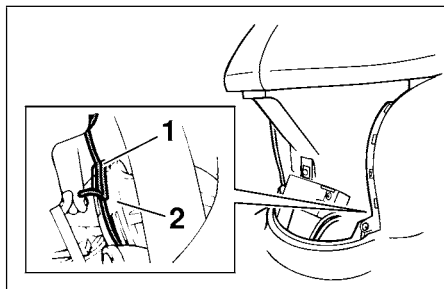

1. Clamp
 2. Carburetor intake
2. Remove the air filter case cover by removing the screws, then pulling the cover off while squeezing the clamp.

ECA00086

CAUTION:

Make sure that no foreign material enters the carburetor intake.

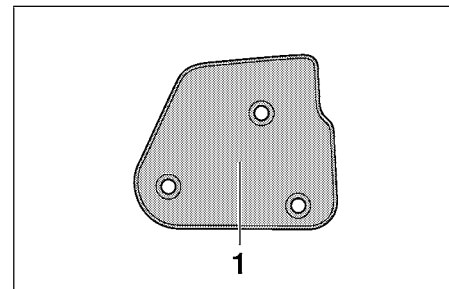

1. Air filter element
3. Pull the air filter element out, clean it with solvent, and then squeeze the remaining solvent out.

EW000075

WARNING

Use only a dedicated parts cleaning solvent. To avoid the risk of fire or explosion, do not use gasoline or solvents with a low flash point.

PERIODIC MAINTENANCE AND MINOR REPAIR

EAU00631

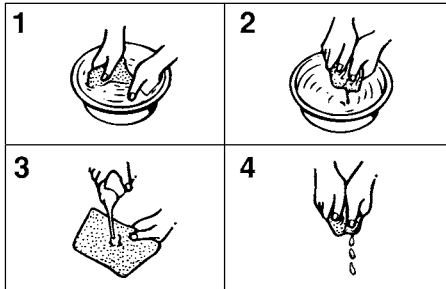

EC000090

CAUTION:

To avoid damaging the air filter element, handle it gently and carefully, and do not twist it.

4. Apply oil of the recommended type to the entire surface of the air filter element, and then squeeze the excess oil out.

NOTE:

The air filter element should be wet but not dripping.

Recommended oil:
2-stroke engine oil

5. Insert the element into the air filter case.

EC000082

CAUTION:

- Make sure that the air filter element is properly seated in the air filter case.
- The engine should never be operated without the air filter element installed, otherwise the piston and/or cylinder may become excessively worn.

6. Install the air filter case cover by placing it in the original position, fastening it with the clamp, then installing the screws.
7. Install the panel.

Adjusting the carburetor

The carburetor is an important part of the engine and requires very sophisticated adjustment. Therefore, all carburetor adjustments should be left to a Yamaha dealer, who has the necessary professional knowledge and experience.

PERIODIC MAINTENANCE AND MINOR REPAIR

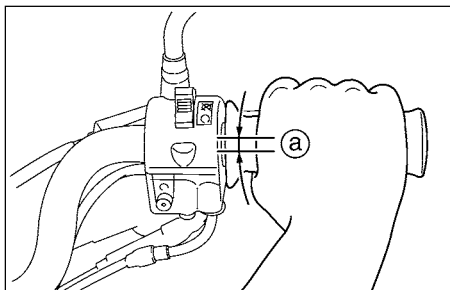

a. Throttle cable free play

EAU00635

Adjusting the throttle cable free play

The throttle cable free play should measure 1.5–3.5 mm (0.06–0.14 in) at the throttle grip. Periodically check the throttle cable free play and, if necessary, have a Yamaha dealer adjust it.

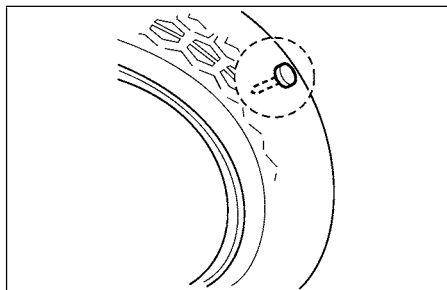

EAU03991

Tires

To maximize the performance, durability, and safe operation of your scooter, note the following points regarding the specified tires.

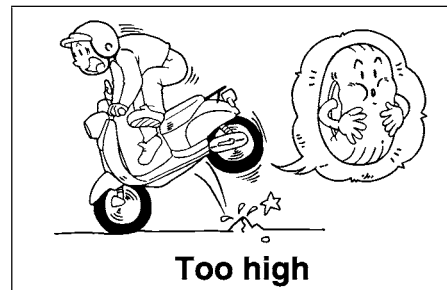

Tire air pressure

The tire air pressure should be checked and, if necessary, adjusted before each ride.

EW000089

⚠ WARNING

Because loading has an enormous impact on the handling, braking, performance and safety characteristics of your scooter, you should keep the following precautions in mind.

PERIODIC MAINTENANCE AND MINOR REPAIR

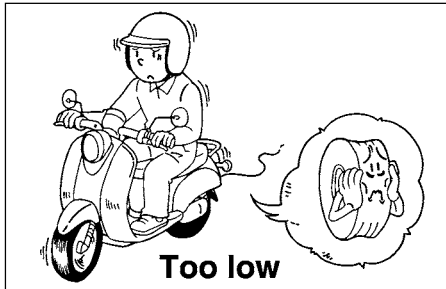

- **NEVER OVERLOAD THE SCOOTER!** Operation of an overloaded scooter may result in tire damage, loss of control, or severe injury. Make sure that the total weight of rider, cargo, and accessories does not exceed the specified maximum load for the vehicle.
- **Improper tire air pressure greatly affects tire life and handling.**
- **If the tire air pressure is too high, shocks from the road will not be dampened but instead be transmitted to the frame and handlebars, which impairs**

riding comfort. In addition, the scooter will be unstable in curves.

- **If the tire air pressure is too low, the tires will be damaged and the tire life shortened. In addition, the tires could slip off the wheel rims during braking, which could result in tube damage. The scooter could also easily turn over in a curve.**

Tire air pressure (measured on cold tires)	
Front	Rear
150 kPa (1.50 kg/cm ² 21 psi)	175kPa (1.75 kg/cm ² 25 psi)

Maximum load*	75 kg (165 lb)
---------------	----------------

* Total weight of rider, cargo and accessories

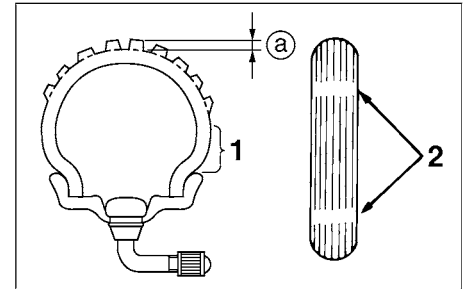

1. Sidewall
2. Tire wear indicator
- a. Tire tread depth

Tire inspection

Always check the tires before operating the scooter. If a tire tread shows crosswise lines (minimum tread depth), if the tire has a nail or glass fragments in it, or if the sidewall is cracked, contact a Yamaha dealer immediately and have the tire replaced.

Minimum tire tread depth (front and rear)	1.0 mm (0.04 in)
----------------------------------------------	------------------

PERIODIC MAINTENANCE AND MINOR REPAIR

EW000079

⚠ WARNING

- Have a Yamaha dealer replace excessively worn tires. Besides being illegal, operating the scooter with excessively worn tires decreases riding stability and can lead to loss of control.
- The replacement of all wheel- and brake-related parts, including the tires, should be left to a Yamaha dealer, who has the necessary professional knowledge and experience.

Tire information

This scooter is equipped with panel wheels and tubeless tires.

FRONT

Manufacturer	Size	Model
IRC	80/90-10 34J	MB38
CHENG-SHIN	80/90-10 34J	C922

REAR

Manufacturer	Size	Model
IRC	80/90-10 34J	MB38
CHENG SHIN	80/90-10 34J	C922

EAU00682*

⚠ WARNING

- It is dangerous to ride with a worn-out tire. When a tire tread begins to show cross-wise lines, have a Yamaha dealer replace the tire immediately.

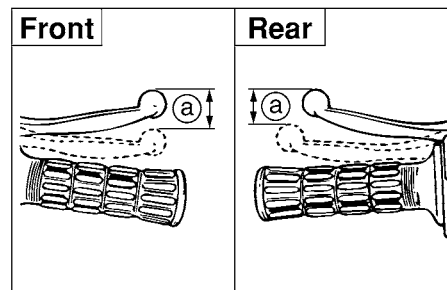

a. Brake lever free play

EAU00702

Adjusting the front and rear brake lever free play

The front and rear brake lever free play should measure 10–20 mm (0.4–0.8 in) as shown. Periodically check the front and rear brake lever free play and, if necessary, adjust them as follows.

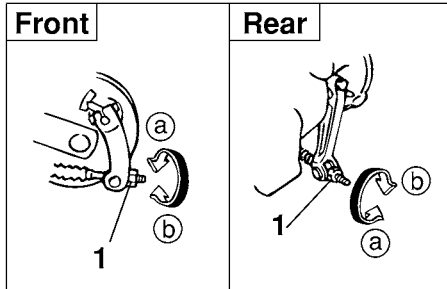

1. Brake lever free play adjusting nut

To increase the brake lever free play, turn the adjusting nut at the brake shoe plate in direction (a). To decrease the brake lever free play, turn the adjusting nut in direction (b).

EW000101

⚠ WARNING

If proper adjustment cannot be obtained as described, have a Yamaha dealer make this adjustment.

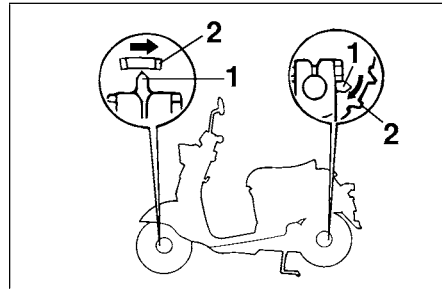

1. Brake shoe wear indicator
2. Wear limit

EAU00719

Checking the front and rear brake shoes

The front and rear brake shoes must be checked for wear at the intervals specified in the periodic maintenance and lubrication chart. Each brake is provided with a wear indicator, which allows you to check the brake shoe wear without having to disassemble the brake. To check the brake shoe wear, check the position of the wear indicator while applying the brake. If a brake shoe has worn to the point that the wear indicator reaches the wear limit line, have a Yamaha dealer replace the brake shoes as a set.

Adjusting the Autolube pump

The Autolube pump is a vital and sophisticated component of the engine, which must be adjusted by a Yamaha dealer at the intervals specified in the periodic maintenance and lubrication chart.

PERIODIC MAINTENANCE AND MINOR REPAIR

Battery

This motorcycle is equipped with a sealed-type (MF) battery, which does not require any maintenance. There is no need to check the electrolyte or to add distilled water.

EAU03989

EW000116

⚠ WARNING

- **Electrolyte is poisonous and dangerous since it contains sulfuric acid, which causes severe burns. Avoid any contact with skin, eyes or clothing and always shield your eyes when working near batteries. In case of contact, administer the following FIRST AID.**

- **EXTERNAL:** Flush with plenty of water.
- **INTERNAL:** Drink large quantities of water or milk and immediately call a physician.
- **EYES:** Flush with water for 15 minutes and seek prompt medical attention.

- **Batteries produce explosive hydrogen gas. Therefore, keep sparks, flames, cigarettes, etc., away from the battery and provide sufficient ventilation when charging it in an enclosed space.**
- **KEEP THIS AND ALL BATTERIES OUT OF THE REACH OF CHILDREN.**

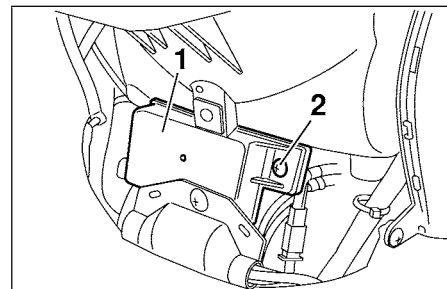

1. Battery box cover
2. Screw

To remove the battery

1. Remove panel A. (See page 6-4 for panel removal and installation procedures.)
2. Remove the battery box cover by removing the screw.
3. Pull the battery out from the battery box, and then disconnect the battery coupler.

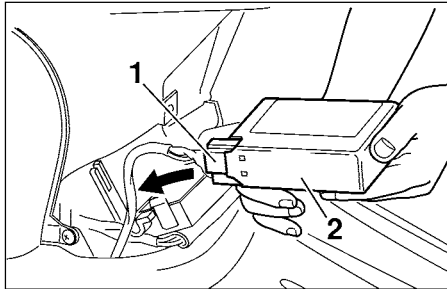

1. Battery coupler
2. Battery

To install the battery

1. Connect the battery coupler, and then place the battery in the original position.
2. Install the battery box cover by installing the screw.
3. Install the panel.

To charge the battery

Have a Yamaha dealer charge the battery as soon as possible if it seems to have discharged. Keep in mind that the battery tends to discharge more quickly if the motorcycle is equipped with optional electrical accessories.

To store the battery

1. If the motorcycle will not be used for more than one month, remove the battery, fully charge it, and then place it in a cool, dry place.
2. If the battery will be stored for more than two months, check it at least once a month and fully charge it if necessary.
3. Fully charge the battery before installation.

CAUTION:

- Always keep the battery charged. Storing a discharged battery can cause permanent battery damage.
- To charge a sealed-type (MF) battery, a special (constant-voltage) battery charger is required. Using a conventional battery charger will damage the battery. If you do not have access to a sealed-type (MF) battery charger, have a Yamaha dealer charge your battery.

PERIODIC MAINTENANCE AND MINOR REPAIR

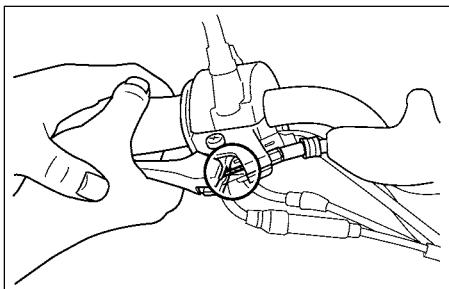

EAU03471

Lubricating the brake lever

The pivoting points of the brake lever must be lubricated at the intervals specified in the General maintenance and lubrication chart.

Recommended lubricant:
Lithium-soap-based grease
(all-purpose grease)

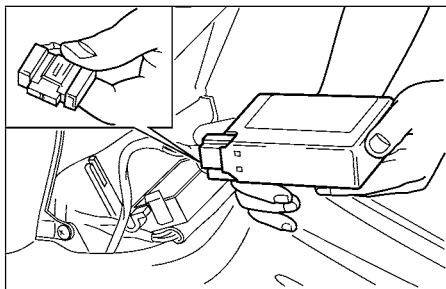

EAU00824

Replacing the fuse

The fuse is located inside the battery lead coupler. If the fuse is blown, replace it as follows.

1. Turn the key to "OFF" and turn off all electrical circuits.
2. Remove the blown fuse, and then install a new fuse of the specified amperage.

Specified fuse: 7.5 A

EC000103

CAUTION:

Do not use a fuse of a higher amperage rating than recommended to avoid causing extensive damage to the electrical system and possibly a fire.

3. Turn the key to "ON" and turn on the electrical circuits to check if the devices operate.
4. If the fuse immediately blows again, have a Yamaha dealer check the electrical system.

EAU01008

Troubleshooting

Although Yamaha scooters receive a thorough inspection before shipment from the factory, trouble may occur during operation. Any problem in the fuel, compression, or ignition systems, for example, can cause poor starting and loss of power.

The following troubleshooting chart represents a quick and easy procedure for checking these vital systems yourself. However, should your scooter require any repair, take it to a Yamaha dealer, whose skilled technicians have the necessary tools, experience, and know-how to service the scooter properly.

Use only genuine Yamaha replacement parts. Imitation parts may look like Yamaha parts, but they are often inferior, have a shorter service life and can lead to expensive repair bills.

PERIODIC MAINTENANCE AND MINOR REPAIR

EAU01397

Troubleshooting chart

EW000125

⚠WARNING

Keep away open flames and do not smoke while checking or working on the fuel system.

1. Fuel

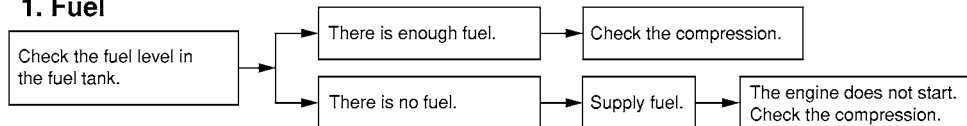

2. Compression

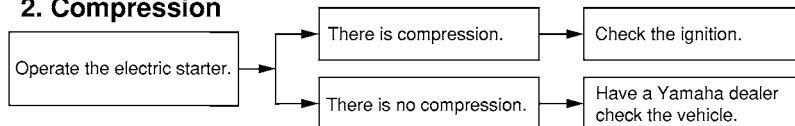

3. Ignition

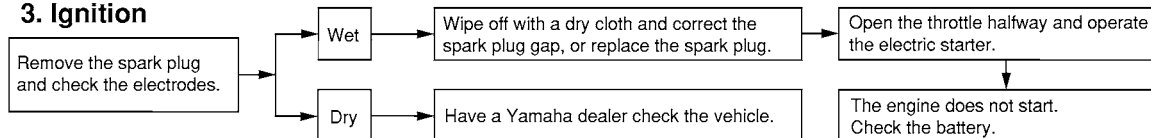

4. Battery

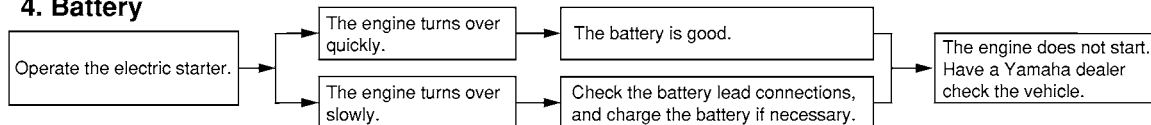

Care

While the open design of a scooter reveals the attractiveness of the technology, it also makes it more vulnerable. Rust and corrosion can develop even if high-quality components are used. A rusty exhaust pipe may go unnoticed on a car, however, it detracts from the overall appearance of a scooter. Frequent and proper care does not only comply with the terms of the warranty, but it will also keep your scooter looking good, extend its life and optimize its performance.

Before cleaning

1. Cover the muffler outlet with a plastic bag after the engine has cooled down.
2. Make sure that all caps and covers as well as all electrical couplers and connectors, including the spark plug cap, are tightly installed.
3. Remove extremely stubborn dirt, like oil burnt onto the crankcase, with a degreasing agent and a brush, but never apply such products onto seals, gaskets and wheel axles. Always rinse the dirt and degreaser off with water.

Cleaning

ECA00011

CAUTION:

- **Avoid using strong acidic wheel cleaners, especially on spoked wheels. If such products are used on hard-to-remove dirt, do not leave the cleaner on the affected area any longer than instructed. Also, thoroughly rinse the area off with water, immediately dry it, and then apply a corrosion protection spray.**
- **Improper cleaning can damage windshields, cowlings, panels and other plastic parts. Use only a soft, clean cloth or sponge with mild detergent and water to clean plastic.**

SCOOTER CARE AND STORAGE

- Do not use any harsh chemical products on plastic parts. Be sure to avoid using cloths or sponges which have been in contact with strong or abrasive cleaning products, solvent or thinner, fuel (gasoline), rust removers or inhibitors, brake fluid, antifreeze or electrolyte.
- Do not use high-pressure washers or steam-jet cleaners since they cause water seepage and deterioration in the following areas: seals (of wheel and swingarm bearings, fork and brakes), electric components (couplers, connectors, instruments, switches and lights), breather hoses and vents.

- For scooters equipped with a windshield: Do not use strong cleaners or hard sponges as they will cause dulling or scratching. Some cleaning compounds for plastic may leave scratches on the windshield. Test the product on a small hidden part of the windshield to make sure that it does not leave any marks. If the windshield is scratched, use a quality plastic polishing compound after washing.

After normal use

Remove dirt with warm water, a mild detergent, and a soft, clean sponge, and then rinse thoroughly with clean water. Use a toothbrush or bottle-brush for hard-to-reach areas. Stubborn dirt and insects will come off more easily if the area is covered with a wet cloth for a few minutes before cleaning.

After riding in the rain, near the sea or on salt-sprayed roads

Since sea salt or salt sprayed on the roads during winter are extremely corrosive in combination with water, carry out the following steps after each ride in the rain, near the sea or on salt-sprayed roads.

NOTE: _____

Salt sprayed on roads in the winter may remain well into spring.

1. Clean the scooter with cold water and a mild detergent after the engine has cooled down.

ECA00012

CAUTION: _____

Do not use warm water since it increases the corrosive action of the salt.

2. Apply a corrosion protection spray on all metal, including chrome- and nickel-plated, surfaces to prevent corrosion.

After cleaning

1. Dry the scooter with a chamois or an absorbing cloth.
2. Use a chrome polish to shine chrome, aluminum and stainless-steel parts, including the exhaust system. (Even the thermally induced discoloring of stainless-steel exhaust systems can be removed through polishing.)
3. To prevent corrosion, it is recommended to apply a corrosion protection spray on all metal, including chrome- and nickel-plated, surfaces.
4. Use spray oil as a universal cleaner to remove any remaining dirt.
5. Touch up minor paint damage caused by stones, etc.
6. Wax all painted surfaces.
7. Let the scooter dry completely before storing or covering it.

EWA00002

⚠ WARNING

- **Make sure that there is no oil or wax on the brakes or tires. If necessary, clean the brake discs and brake linings with a regular brake disc cleaner or acetone, and wash the tires with warm water and a mild detergent.**
- **Before operating the scooter test its braking performance and cornering behavior.**

ECA00013

CAUTION:

- **Apply spray oil and wax sparingly and make sure to wipe off any excess.**
- **Never apply oil or wax to any rubber and plastic parts, but treat them with a suitable care product.**
- **Avoid using abrasive polishing compounds as they will wear away the paint.**

NOTE:

Consult a Yamaha dealer for advice on what products to use.

SCOOTER CARE AND STORAGE

Storage

Short-term

Always store your scooter in a cool, dry place and, if necessary, protect it against dust with a porous cover.

ECA00015

CAUTION:

- **Storing the scooter in a poorly ventilated room or covering it with a tarp, while it is still wet, will allow water and humidity to seep in and cause rust.**
 - **To prevent corrosion, avoid damp cellars, stables (because of the presence of ammonia) and areas where strong chemicals are stored.**
-

Long-term

Before storing your scooter for several months:

1. Follow all the instructions in the “Care” section of this chapter.
2. Drain the carburetor float chamber by loosening the drain bolt; this will prevent fuel deposits from building up. Pour the drained fuel into the fuel tank.
3. Fill up the fuel tank and add fuel stabilizer (if available) to prevent the fuel tank from rusting and the fuel from deteriorating.
4. Perform the following steps to protect the cylinder, piston rings, etc. from corrosion.
 - a. Remove the spark plug cap and spark plug.
 - b. Pour a teaspoonful of engine oil into the spark plug bore.

- c. Install the spark plug cap onto the spark plug, and then place the spark plug on the cylinder head so that the electrodes are grounded. (This will limit sparking during the next step.)
- d. Turn the engine over several times with the starter. (This will coat the cylinder wall with oil.)
- e. Remove the spark plug cap from the spark plug, and then install the spark plug and the spark plug cap.

EWA00003

WARNING

To prevent damage or injury from sparking, make sure to ground the spark plug electrodes while turning the engine over.

5. Lubricate all control cables and the pivoting points of all levers and pedals as well as of the sidestand/centerstand.
6. Check and, if necessary, correct the tire air pressure, and then lift the scooter so that both of its wheels are off the ground. Alternatively, turn the wheels a little every month in order to prevent the tires from becoming degraded in one spot.
7. Cover the muffler outlet with a plastic bag to prevent moisture from entering it.
8. Remove the battery and fully charge it. Store it in a cool, dry place and charge it once a month. Do not store the battery in an excessively cold or warm place [less than 0 °C (30 °F) or more than 30 °C (90 °F)]. For more information on storing the battery, see page 6-15.

NOTE: _____
Make any necessary repairs before storing the scooter.

SPECIFICATIONS

Specifications

Model	YJ50R
Dimensions	
Overall length	1,620 mm (63.8 in)
Overall width	630 mm (24.8 in)
Overall height	1,005 mm (39.6 in)
Seat height	715 mm (28.2 in)
Wheelbase	1,150 mm (45.3 in)
Ground clearance	85 mm (3.4 in)
Minimum turning radius	1,600 mm (63.0 in)
Basic weight (with oil and full fuel tank)	74 kg (163 lb)
Engine	
Engine type	Air cooled 2-stroke
Cylinder arrangement	Forward inclined single cylinder
Displacement	49 cm ³
Bore × Stroke	40.0 × 39.2 mm (1.57 × 1.54 in)
Compression ratio	7.3:1
Starting system	Electric and kick starter
Lubrication system	Separate lubrication (Yamaha autolube)

Engine oil	
Type	YAMALUBE 2-cycle oil or 2-stroke engine oil
Quantity	
Total amount	1.3 L (1.14 Imp qt, 1.37 US qt)
Transmission oil	
Type	Yamalube 4, SAE10W30SE or GL gear oil
Quantity	
Periodic oil change	0.1 L (0.09 Imp qt, 0.11 US qt)
Total amount	0.11 L (0.1 Imp qt, 0.12 US qt)
Air filter	Wet type element
Fuel	
Type	Unleaded fuel
Fuel tank capacity	6 L (1.32 Imp gal, 1.59 US gal)
Carburetor	
Manufacturer	TEIKEI
Model × quantity	Y14P × 1
Spark plug	
Manufacturer/model	NGK / BPR7HS
Gap	0.6–0.7 mm (0.024–0.028 in)
Clutch type	Wet, centrifugal automatic

Transmission

Primary reduction system	Helical gear
Primary reduction ratio	3.692
Secondary reduction system	Spur gear
Secondary reduction ratio	3.230
Transmission type	V-belt automatic
Operation	Centrifugal automatic type

Chassis

Frame type	Steel tube underbone
Caster angle	25°
Trail	71 mm (2.8 in)

Tires

Front		
	Type	Tubeless tire
	Size	80/90-10 34J
	Manufacturer/ model	INOUE / MB38 CHENG-SHIN / C-922
Rear		
	Type	Tubeless tire
	Size	80/90-10 34J
	Manufacturer/ model	INOUE / MB38 CHENG-SHIN / C-922
Maximum load*		75 kg (165 lb)

Tire air pressure (measured on cold tires)

Front	150 kPa (1.50 kgf/cm ² , 21 psi)
Rear	175 kPa (1.75 kgf/cm ² , 25 psi)

Wheels

Front		
	Type	Panel wheel
	Size	10 × 2.15
Rear		
	Type	Panel wheel
	Size	10 × 2.15

Brakes

Front		
	Type	Drum brake
	Operation	Right hand
Rear		
	Type	Drum brake
	Operation	Left hand

Suspension

Front	Bottom link fork
Rear	Unit swing

Spring/shock absorber

Front	Coil spring / oil damper
Rear	Coil spring / oil damper

SPECIFICATIONS

Wheel travel

Front	52 mm (2.05 in)
Rear	46 mm (1.81 in)

Electrical system

Ignition system	DC. C.D.I.
Charging system	
Type	AC magneto
Battery	
Model	GT4B-5
Voltage, capacity	12 V, 2.5 Ah
Headlight type	Bulb

Bulb voltage, wattage × quantity

Headlight	12 V, 35/35 W × 1
Tail/brake light	12 V, 8/27 W × 1
Front turn signal light	12 V, 10 W × 2
Rear turn signal light	12 V, 10 W × 2
Meter lighting	12 V, 1.7 W × 1
High beam indicator light	12 V, 1.7 W × 1
Oil level warning light	12 V, 1.7 W × 1
Turn signal indicator light	14 V, 3 W × 1

Fuse	7.5 A
-------------	-------

Identification numbers

Record the key identification number, vehicle identification number and model label information in the spaces provided below for assistance when ordering spare parts from a Yamaha dealer or for reference in case the vehicle is stolen.

1. KEY IDENTIFICATION NUMBER:

2. VEHICLE IDENTIFICATION NUMBER:

3. MODEL LABEL INFORMATION:

EAU02944

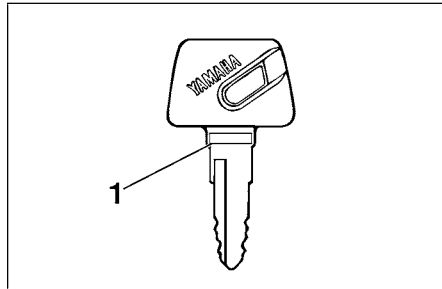

1. Key identification number

EAU01042

Key identification number

The key identification number is stamped into the key.

Record this number in the space provided and use it for reference when ordering a new key.

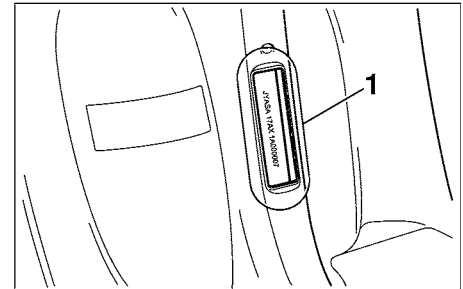

1. Vehicle identification number

EAU01044

Vehicle identification number

The vehicle identification number is stamped into the frame.

NOTE: _____

The vehicle identification number is used to identify your scooter and may be used to register your scooter with the licensing authority in your area.

CONSUMER INFORMATION

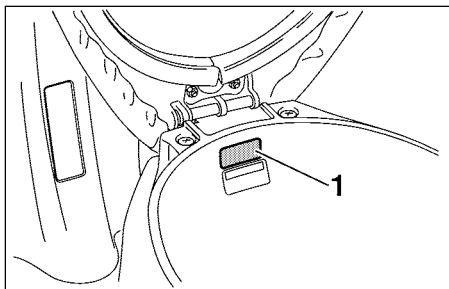

1. Model label

EAU03097

Model label

The model label is affixed to the inside of the rear storage compartment. (See page 3-10 for rear storage compartment opening and closing procedures.) Record the information on this label in the space provided. This information will be needed when ordering spare parts from a Yamaha dealer.

Reporting safety defects

If you believe that your vehicle has a defect which could cause a crash or could cause injury or death, you should immediately inform the National Highway Traffic Safety Administration (NHTSA) in addition to notifying Yamaha Motor Corporation, U.S.A. If NHTSA receives similar complaints, it may open an investigation, and if it finds that a safety defect exists in a group of vehicles, it may order a recall and remedy campaign. However, NHTSA cannot become involved in individual problems between you, your dealer, or Yamaha Motor Corporation, U.S.A.

To contact NHTSA, you may either call the Auto Safety Hotline toll-free at 1-800-424-9393 (or 366-0123 in Washington, D.C. area) or write to: NHTSA, U.S. Department of Transportation, Washington, D.C. 20590. You can also obtain other information about motor vehicle safety from the Hotline.

CONSUMER INFORMATION

EAU01055

Scooter noise regulation

TAMPERING WITH NOISE CONTROL SYSTEM PROHIBITED: Federal law prohibits the following acts or the causing thereof: (1) The removal or rendering inoperative by any person other than for purposes of maintenance, repair, or replacement of any device or element of design incorporated into any new vehicle for the purpose of noise control prior to its sale or delivery to the ultimate purchaser or while it is in use or (2) the use of the vehicle after such device or element of design has been removed or rendered inoperative by any person.

“AMONG THOSE ACTS PRESUMED TO CONSTITUTE TAMPERING ARE THE ACTS LISTED BELOW.”

These acts include tampering with the following systems; i.e., modification, removal, etc.

Exhaust system	Muffler Exhaust pipe Silencer
Intake system	Air cleaner case Air cleaner element Intake duct

YAMAHA MOTOR CORPORATION, U.S.A. RIVA LIMITED WARRANTY

Yamaha Motor Corporation, U.S.A. hereby warrants that each new Yamaha Riva purchased from an authorized Yamaha Riva dealer in the continental United States will be free from defects in material and workmanship for the period of time stated herein, subject to certain stated limitations.

THE PERIOD OF WARRANTY for Yamaha Riva shall be one (1) year from the date of purchase, with no mileage limitation.

MODELS EXCLUDED FROM WARRANTY include those used for non-Yamaha-authorized renting, leasing, or other commercial purposes.

DURING THE PERIOD OF WARRANTY any authorized Yamaha motorcycle dealer will, free of charge, repair or replace any part adjudged defective by Yamaha due to faulty workmanship or material from the factory. Parts used in warranty repairs will be warranted for the balance of the product's warranty period. All parts replaced under warranty become property of Yamaha Motor Corp. U.S.A.

GENERAL EXCLUSIONS from this warranty shall include any failures caused by:

- a. Competition or racing use.
- b. Installation of parts or accessories that are not qualitatively equivalent to genuine Yamaha parts.
- c. Abnormal strain, neglect, or abuse.
- d. Lack of proper maintenance.
- e. Accident or collision damage.

SPECIFIC EXCLUSIONS from this warranty shall include parts replaced due to normal wear or routine maintenance.

THE CUSTOMER'S RESPONSIBILITY under this warranty shall be to:

1. Operate and maintain the Riva as specified in the appropriate Owner's Manual, and

2. Give notice to an authorized Yamaha Riva dealer of any and all apparent defects within ten (10) days after discovery, and make the machine available at that time for inspection and repairs at such dealer's place of business.

WARRANTY TRANSFER: To transfer the warranty from the original purchaser to any subsequent purchaser, it is imperative that the machine be inspected and registered for warranty by an authorized Yamaha Riva dealer. In order for this warranty to remain in effect, this inspection and registration must take place within (10) days after transfer. An inspection and registration fee will be charged for this service.

EMISSIONS CONTROL SYSTEM WARRANTY

Yamaha Motor Corporation, U.S.A. also warrants to the ultimate purchaser and each subsequent purchaser of each Yamaha Riva covered by this warranty with a displacement of 50cc or greater, that the vehicle is designed, built, and equipped so as to conform at the time of sale with all U.S. emissions standards applicable at the time of manufacture and that it is free from defects in materials and workmanship which would cause it not to meet these standards within the periods listed immediately below. Failure other than those resulting from defects in material or workmanship which arise solely as a result of owner abuse and / or lack of proper maintenance are not covered by this warranty.

ENGINE

DISPLACEMENT	PERIOD
50cc to 169cc	12,000 km (7,465 miles) or five years, whichever occurs first
170cc to 279cc	18,000 km (11,185 miles) or five years, whichever occurs first
280cc or over	30,000 km (18,641 miles) or five years, whichever occurs first

YAMAHA MOTOR CORPORATION, U.S.A. MAKES NO OTHER WARRANTY OF ANY KIND, EXPRESSED OR IMPLIED. ALL IMPLIED WARRANTIES OF MERCHANTABILITY AND FITNESS FOR A PARTICULAR PURPOSE WHICH EXCEED THE OBLIGATIONS AND TIME LIMITS STATED IN THIS WARRANTY ARE HEREBY DISCLAIMED BY YAMAHA MOTOR CORPORATION, U.S.A. AND EXCLUDED FROM THIS WARRANTY.

SOME STATES DO NOT ALLOW LIMITATIONS ON HOW LONG AN IMPLIED WARRANTY LASTS, SO THE ABOVE LIMITATION MAY NOT APPLY TO YOU. ALSO EXCLUDED FROM THIS WARRANTY ARE ANY INCIDENTAL OR CONSEQUENTIAL DAMAGES INCLUDING LOSS OF USE. SOME STATES DO NOT ALLOW THE EXCLUSION OR LIMITATION OF INCIDENTAL OR CONSEQUENTIAL DAMAGES, SO THE ABOVE EXCLUSION MAY NOT APPLY TO YOU.

THIS WARRANTY GIVES YOU SPECIFIC LEGAL RIGHTS, AND YOU MAY ALSO HAVE OTHER RIGHTS WHICH VARY FROM STATE TO STATE.

YAMAHA MOTOR CORPORATION, U.S.A.
P. O. Box 6555
Cypress, California 90630

- Q. What costs are my responsibility during the warranty period?
- A. The customer's responsibility includes all costs of normal maintenance services, non-warranty repairs, accident and collision damages, and oil, oil filters, air filters, spark plugs, and brake shoes.
- Q. What are some examples of "abnormal" strain, neglect, or abuse?
- A. These terms are general and overlap each other in areas. Specific examples include: Running the machine out of oil, sustained high-rpm, full-throttle, operating the machine with a broken or damaged part which causes another part to fail, damage or failure due to improper or careless transportation and or tie down. If you have any specific questions on operation or maintenance, please contact your dealer for advice.
- Q. Does the warranty cover incidental costs such as towing or transportation due to a failure?
- A. No. The warranty is limited to repair of the machine itself.
- Q. May I perform any or all of the recommended maintenance shown in the Owner's Manual instead of having the dealer do them?
- A. Yes, if you are a qualified mechanic and follow the procedures specified in the Owner's and Service Manual. We do recommend, however, that items requiring special tools or equipment be done by a Yamaha Riva dealer.
- Q. Will the warranty be void or cancelled if I do not operate or maintain my new Riva exactly as specified in the Owner's Manual?
- A. No. The warranty on a new Riva cannot be "voided" or "cancelled." **However, if a particular failure is caused by operation or maintenance other than as shown in the Owner's Manual, that failure may not be covered under warranty.**
- Q. What responsibility does my dealer have under this warranty?
- A. Each Yamaha Riva dealer is expected to:
1. Completely set up every new machine before sale.
 2. Explain the operation, maintenance, and warranty requirements to your satisfaction at the time of sale, and upon your request at any later date.
 3. Each Yamaha Riva dealer is held responsible for his setup, service and warranty repair work.
- Q. Is the warranty transferable to second owners?
- A. Yes. The remainder of the existing warranty can be transferred upon request. The unit has to be inspected and re-registered by an authorized Yamaha Riva dealer for the policy to remain effective.

If your machine requires warranty service, you must take it to any authorized Yamaha Riva dealer within the continental United States. Be sure to bring your warranty registration card or other valid proof of the original date of purchase. If a question or problem arises regarding warranty, first contact the owner of the dealership. Since all warranty matters are handled at the dealer level, this person is in the best position to help you. If you are still not satisfied and require additional assistance, please write:

YAMAHA MOTOR CORPORATION U.S.A.
CUSTOMER RELATIONS DEPARTMENT
P.O. Box 6555
Cypress, California 90630

When contacting Yamaha Motor Corporation, U.S.A. don't forget to include any important information such as names, addresses, model, V.I.N (frame number), dates, and receipts.

CHANGE OF ADDRESS

The federal government requires each manufacturer of a motor vehicle to maintain a complete, up-to-date list of all first purchasers against the possibility of a safety-related defect and recall. This list is compiled from the purchase registrations sent to Yamaha Motor Corporation, U.S.A. by the selling dealer at the time of your purchase.

If you should move after you have purchased your new motorcycle, please advise us of your new address by sending a postcard listing your Riva model name, V.I.N (frame number), dealer number (or dealer's name) as it is shown on your warranty card, your name and new mailing address. Mail to:

YAMAHA MOTOR CORPORATION, U.S.A.
P.O. Box 6555
Cypress, California 90630
Attention: Warranty Department

This will ensure that Yamaha Motor Corporation, U.S.A. has an up-to-date registration record in accordance with federal law.

YAMAHA EXTENDED SERVICE (Y.E.S.)

Keep your Yamaha protected even after your warranty expires with genuine Yamaha Extended Service (Y.E.S.).

- Y.E.S. is designed and administered by Yamaha Motor Corporation to provide maximum owner satisfaction. You get uninterrupted factory-backed coverage for extra peace of mind.
- Y.E.S. is flexible. You choose the plan that's right for you: 12 months, 24 months, or 36 months beyond your warranty period.
- Y.E.S. is designed and administered by the same Yamaha people who handle your warranty — and it shows in the comprehensive coverage benefits. There are no mileage limitations. Coverage isn't limited to "moving parts" or the "drive train" like many other plans. And Y.E.S. covers manufacturing defects just like the warranty. See the sample contract at your Yamaha dealer to see how comforting uninterrupted factory-backed protection can be.
- You don't have to pay anything for covered repairs. There's no deductible to pay, and repairs aren't "pro-rated." You don't have any "out-of-pocket" expenses for covered repairs.
- In addition, Travel and Recreation Interruption Protection (TRIP) is included at no extra cost. TRIP gives you up to \$150 reimbursement per occurrence for any reasonable expenses you incur because your Yamaha needs covered service: replacement vehicle rental, emergency towing, phone calls, even food and lodging when you are away from home. This superb coverage goes into effect when you purchase Y.E.S., so it applies to any warranty repairs as well as covered repairs during your entire Y.E.S. plan period.
- Y.E.S. coverage is honored at any authorized Yamaha dealer nationwide.
- Y.E.S. coverage is transferrable to a new owner if you sell or trade-in. That can make your Yamaha much more valuable!

This excellent Y.E.S. plan coverage is only available to Yamaha owners like you, and only while your Yamaha is still within the Yamaha Limited Warranty period. So visit your authorized Yamaha dealer to get all the facts. He can show you how easy it is to protect your investment with Yamaha Extended Service.

We urge you to act now. You'll get the excellent benefits of TRIP coverage right away, and you'll rest easy knowing you'll have strong factory-backed protection even after your Yamaha Limited Warranty expires. You can also save money: Y.E.S. costs less within the first 90 days after you buy your Yamaha. See your dealer today!

A special note:

If visiting your dealer isn't convenient, contact Yamaha with your Primary ID number (your frame number). We'll be happy to help you get the Y.E.S. coverage you need.

Yamaha Service Marketing
P.O. Box 6555
Cypress, CA 90630



YAMAHA EXTENDED SERVICE

PROTECT YOUR INVESTMENT

Use Genuine YAMAHA Parts And Accessories.

See your Authorized YAMAHA Dealer for a Genuine YAMAHA Service Manual.



YAMAHA

YAMAHA MOTOR CO., LTD.

PRINTED ON RECYCLED PAPER

PRINTED IN JAPAN

2000-11-3.2x1(E) 