

YAMAHA

OWNER'S MANUAL

JOG
CY50L

LIT-11626-12-11

4FE-28199-18

Congratulations on your purchase of the Yamaha CY50. This model is the result of Yamaha's vast experience in the production of fine sporting, touring, and pacesetting racing machines. It represents the high degree of craftsmanship and reliability that have made Yamaha a leader in these fields.

This manual will give you an understanding of the operation, inspection, and basic maintenance of this scooter. If you have any questions about the operation or maintenance of your scooter, please consult a Yamaha dealer.

IMPORTANT MANUAL INFORMATION

EAU00003

Particularly important information is distinguished in this manual by the following notations:



The Safety Alert Symbol means **ATTENTION! BECOME ALERT! YOUR SAFETY IS INVOLVED!**



Failure to follow **WARNING** instructions could result in severe injury or death to the scooter operator, a bystander or a person inspecting or repairing the scooter.



A **CAUTION** indicates special precautions that must be taken to avoid damage to the scooter.

NOTE:

A **NOTE** provides key information to make procedures easier or clearer.

NOTE: _____

- This manual should be considered a permanent part of this scooter and should remain with it even if the scooter is subsequently sold.
 - Yamaha continually seeks advancements in product design and quality. Therefore, while this manual contains the most current product information available at the time of printing, there may be minor discrepancies between your scooter and this manual. If there is any question concerning this manual, please consult your Yamaha dealer.
-

IMPORTANT MANUAL INFORMATION

EW000000

WARNING

PLEASE READ THIS MANUAL AND THE “YOU AND YOUR MOTORCYCLE: RIDING TIPS” BOOKLET CAREFULLY AND COMPLETELY BEFORE OPERATING THIS SCOOTER. DO NOT ATTEMPT TO OPERATE THIS SCOOTER UNTIL YOU HAVE ATTAINED A SATISFACTORY KNOWLEDGE OF ITS CONTROLS AND OPERATING FEATURES AND UNTIL YOU HAVE BEEN TRAINED IN SAFE AND PROPER RIDING TECHNIQUES. REGULAR INSPECTIONS AND CAREFUL MAINTENANCE, ALONG WITH GOOD RIDING SKILLS, WILL ENSURE THAT YOU SAFELY ENJOY THE CAPABILITIES AND THE RELIABILITY OF THIS SCOOTER.

AFFIX DEALER

LABEL HERE

EAU01193

CY50L

OWNER'S MANUAL

©1998 by Yamaha Motor Corporation, U.S.A.

1st Edition, May 1998

**All rights reserved. Any reprinting or
unauthorized use without the written
permission of Yamaha Motor Corporation,
U.S.A. is expressly prohibited.**

Printed in Japan

P/N LIT-11626-12-11

1	SAFETY INFORMATION	1-1	Kick starter	3-8	
	Safe riding	1-1	Seat.....	3-9	
	Protective apparel	1-2	Helmet holder	3-9	
	Modification	1-3	Trunk.....	3-10	
	Loading and accessories	1-3	Storage compartment	3-10	
	Gasoline and exhaust gas.....	1-5	Rear carrier	3-11	
	Further safe riding points for this model.....	1-6			
	Location of the important labels	1-7			
2	DESCRIPTION	2-1	4	PRE-OPERATION CHECKS	4-1
	Left view	2-1	5	OPERATION AND IMPORTANT RIDING	
	Controls/Instruments	2-1		POINTS	5-1
	Right view	2-1		Starting and warming up a cold engine	5-1
3	INSTRUMENT AND CONTROL FUNCTIONS	3-1		Starting off.....	5-2
	Main switch/Steering lock.....	3-1		Acceleration	5-3
	Indicator lights	3-2		Braking.....	5-3
	Oil level indicator light circuit check	3-3		Engine break-in.....	5-4
	Speedometer.....	3-4		Parking.....	5-5
	Fuel gauge.....	3-4	6	PERIODIC MAINTENANCE AND MINOR	
	Handlebar switches	3-4		REPAIR	6-1
	Front brake lever	3-5		Periodic maintenance and lubrication	6-2
	Rear brake lever.....	3-5		Spark plug inspection	6-4
	Fuel tank cap	3-6		Air filter element cleaning	6-5
	Fuel.....	3-7		Throttle cable free play inspection.....	6-7
	Engine oil.....	3-8		Tires	6-8

TABLE OF CONTENTS

Front and rear brake lever free play adjustment.....	6-10
Checking the brake shoes	6-10
Battery.....	6-11
Fuse replacement.....	6-12
Troubleshooting	6-13
Troubleshooting chart.....	6-14

7 CLEANING AND STORAGE.....	7-1
A. Cleaning	7-1
B. Storage	7-2

8 SPECIFICATIONS.....	8-1
------------------------------	-----

9 CONSUMER INFORMATION	9-1
Identification numbers record	9-1
Key identification number	9-1
Vehicle identification number.....	9-1
Model label.....	9-2
Reporting safety defects	9-3
Scooter noise regulation.....	9-4
RIVA LIMITED WARRANTY	9-5
YAMAHA EXTENDED SERVICE.....	9-7



SAFETY INFORMATION

EAU00011

TWO-WHEELED SCOOTERS ARE SINGLE TRACK VEHICLES. THEIR SAFE USE AND OPERATION ARE DEPENDENT UPON THE USE OF PROPER RIDING TECHNIQUES AS WELL AS THE EXPERIENCE OF THE OPERATOR.

EVERY OPERATOR SHOULD KNOW THE FOLLOWING REQUIREMENTS BEFORE RIDING. HE OR SHE SHOULD:

1. OBTAIN THOROUGH INSTRUCTIONS FROM A COMPETENT SOURCE ON ALL ASPECTS OF SCOOTER OPERATION.
2. OBSERVE THE WARNINGS AND MAINTENANCE REQUIREMENTS IN THE OWNER'S MANUAL.
3. OBTAIN QUALIFIED TRAINING IN SAFE AND PROPER RIDING TECHNIQUES.
4. OBTAIN PROFESSIONAL TECHNICAL SERVICE AS INDICATED BY THE OWNER'S MANUAL AND/OR WHEN MADE NECESSARY BY MECHANICAL CONDITIONS.

Safe riding

1. Always make pre-operation checks. Careful checks may help prevent an accident.
2. This scooter is designed to carry the operator only. No passengers.
3. The failure of motorists to detect and recognize scooters in traffic is the predominating cause of automobile/scooter accidents. Many accidents have been caused by an automobile driver who did not see the scooter. Making yourself conspicuous appears to be very effective in reducing the chance of this type of accident.

Therefore:

- a. Wear a brightly colored jacket.
- b. Use extra caution when you approach and pass through intersections, since intersections are the most likely places for scooter accidents.
- c. Ride where other motorists can see you. Avoid riding in another motorist's "blind spot".



4. Many accidents involve inexperienced operators. In fact, many operators who have been involved in accidents do not even have a current driver's license.
 - a. Make sure you are qualified. Also, only lend your scooter to experienced operators.
 - b. Know your skills and limits. Staying within your limits may help you to avoid an accident.
 - c. We recommend that you practice riding your scooter where there is no traffic until you have become thoroughly familiar with your scooter and all of its controls.
5. Many scooter accidents have been caused by scooter operator errors. A typical error made by the operator is veering wide on a turn due to EXCESSIVE SPEED or undercornering (insufficient lean angle for the speed).
 - a. Always obey the speed limits and never travel faster than warranted by road and traffic conditions.
 - b. Always signal before turning or changing lanes. Make sure other motorists see you.
6. The operator's posture is important for proper control. The operator should keep both hands on the handlebars and both feet on the footboard during operation to maintain control of the scooter.
7. Never ride under the influence of alcohol or drugs.
8. This scooter is designed for on-road use only. It is not suitable for off-road use.

Protective apparel

The majority of fatalities from scooter accidents are the result of head injuries. The use of a safety helmet is the single most critical factor in the prevention or reduction of head injuries.

1. Always wear an approved helmet.
2. Wear a face shield or goggles. Wind on your unprotected eyes could contribute to an impairment of vision which could delay seeing a hazard.
3. The use of substantial shoes, jacket, trousers, gloves, etc. is effective in preventing or reducing abrasions or lacerations.



SAFETY INFORMATION

4. Never wear loose fitting clothing. It could catch on the control levers or wheels and cause injury or accident.
5. Never touch the engine or exhaust system during or after operation. They become very hot and can cause burns. Always wear protective clothing that covers your legs, ankles, and feet.

Modification

Modifications made to the scooter not approved by Yamaha, or the removal of original equipment, may render your scooter unsafe for use and may cause severe personal injury. Modifications may also make your scooter illegal to use.

Loading and accessories

Adding accessories or cargo to your scooter can adversely affect stability and handling if the weight distribution of the machine is changed. To avoid the possibility of an accident, extreme caution should be used if adding cargo or accessories to your scooter. Use extra care if riding a scooter which has added cargo or accessories. Here are some general guidelines to follow if loading cargo or adding accessories to your scooter:

Loading

The total weight of the operator, accessories and cargo must not exceed the maximum load limit of 165 lbs. (75 kg).

When loading within these weight limits, keep the following in mind:

1. Cargo and accessory weight should be kept as low and close to the scooter as possible. Be sure to distribute the weight as evenly as possible on both sides of the machine to minimize imbalance or instability.



2. Shifting weights can create a sudden imbalance. Make sure that accessories and cargo are securely attached to the scooter before riding. Recheck accessory mounts and cargo restraints frequently.
3. Never attach any large or heavy items to the handlebars, front forks, or front fender. These items can create unstable handling or slow steering response.

Accessories

Genuine Yamaha accessories have been specifically designed for use on this scooter. Since Yamaha cannot test all other accessories which may be available, you must personally be responsible for the proper selection, installation and use of non-Yamaha accessories. You should use extreme caution when selecting and installing any accessories.

Keep in mind these guidelines for mounting accessories in addition to those provided under “LOADING”.

1. Never install accessories or carry cargo that would impair the performance of your scooter. Carefully inspect the accessory before using it to make sure it does not in any way reduce ground clearance or cornering clearance, limit suspension travel, steering travel or control operation, or obscure lights or reflectors.
 - a. Accessories fitted to the handlebar or the front fork area can create instability due to improper weight distribution or aerodynamic changes. If accessories are added to the handlebar or front fork area, they must be as lightweight as possible and should be kept to a minimum.
 - b. Bulky or large accessories may seriously affect the stability of the scooter due to aerodynamic effects. Wind may attempt to lift the scooter, or the scooter may become unstable in cross winds. These accessories may also cause instability when being passed by or passing large vehicles.
 - c. Certain accessories can displace the operator from his or her normal riding position. This improper position limits the freedom of movement of the operator and may limit control ability. Therefore such accessories are not recommended.



SAFETY INFORMATION

2. Caution must be used if adding electrical accessories. If these accessories exceed the capacity of the scooter's electrical system, an electric failure could result, which could cause a dangerous loss of lights or engine power.

Gasoline and exhaust gas

1. **GASOLINE IS HIGHLY FLAMMABLE:**
 - a. Always turn off the engine when refueling.
 - b. Take care not to spill any gasoline on the engine or exhaust system when refueling.
 - c. Never refuel while smoking or in the vicinity of an open flame.
2. Never start the engine or let it run for any length of time in a closed area. The exhaust fumes are poisonous and may cause loss of consciousness and death within a short time. Always operate your scooter in an area that has adequate ventilation.
3. Always turn off the engine before leaving the scooter unattended and remove the ignition key. When parking the scooter, note the following:
 - a. The engine and exhaust system may be hot. Park the scooter in a place where pedestrians or children are not likely to touch these hot areas.
 - b. Do not park the scooter on a slope or soft ground; the scooter may fall over.
 - c. Do not park the scooter near a flammable source, e.g. a kerosene heater, or near an open flame. The scooter could catch fire.
4. If you should swallow any gasoline, inhale a lot of gasoline vapor, or allow gasoline to get in your eyes, see your doctor immediately. If any gasoline spills on your skin or clothing, immediately wash with soap and water and change your clothes.



Further safe riding points for this model

1. Be sure to signal clearly in the following instances:

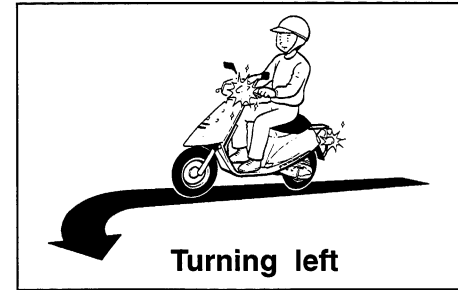
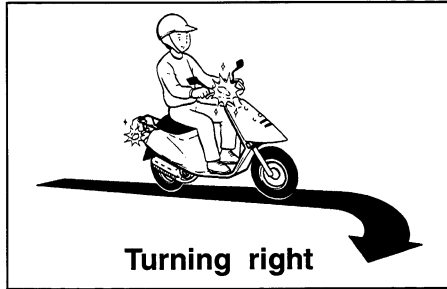

2. Braking can be extremely difficult on a wet road. Avoid hard braking, because the scooter could slide. Apply the brakes slowly when stopping on a wet surface.
3. Slow down as you approach a corner or turn. Once you have completed a turn, accelerate slowly.
4. Be careful when passing parked cars. A driver might not see you and open a door in your path.
5. Street car rails, iron plates on road construction sites, and man-hole covers become extremely slippery when wet. Slow down and cross them with caution. Keep the scooter upright. It could slide out from under you.
6. The brake lining could get wet when you wash the scooter. After washing the scooter, check the brakes before riding.
7. Always wear a helmet, gloves, trousers (tapered around the cuff and ankle so they do not flap), and a bright colored jacket.
8. Do not carry too much luggage on the scooter. An overloaded scooter is unstable. Refer to "SAFETY INFORMATION" for instructions about carrying luggage. Use a strong cord to secure any luggage to the luggage racks. A loose load will affect the stability of the scooter and could divert your attention from the road.



SAFETY INFORMATION

EAU00025

Location of the important labels

Please read the following labels carefully before operating this scooter.

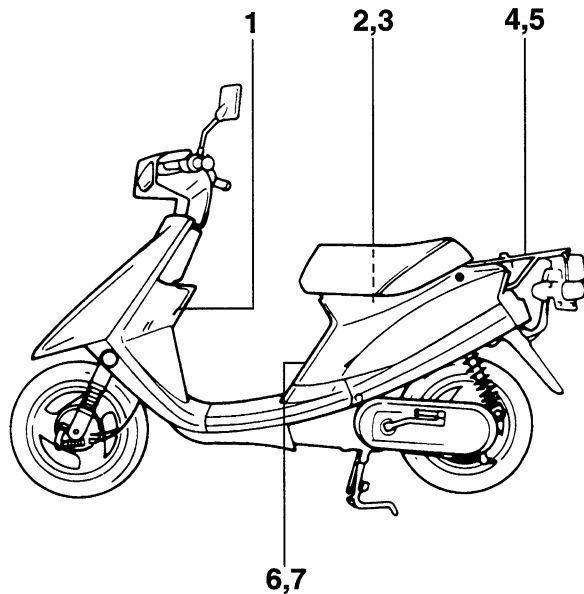



SAFETY INFORMATION

1

①

LOAD LIMIT
1.5 Kg (3 lbs)
YAMAHA 3SA-24877-00

②

⚠ WARNING
Improper loading can cause loss of control. Read owner's manual for proper loading.
YAMAHA 3JJ-28446-00

③

LOAD LIMIT
5 Kg (11 lbs)
YAMAHA 3LD-24877-10

④

LOAD LIMIT
3 Kg (7 lbs)
YAMAHA 3TB-24877-00

⑤

⚠ WARNING
NEVER sit here
YAMAHA 3MX-24875-00

⑥

⚠ WARNING
<ul style="list-style-type: none">● BEFORE YOU OPERATE THIS VEHICLE, READ THE OWNER'S MANUAL AND ALL LABELS.● NEVER CARRY A PASSENGER. You increase your risk of losing control if you carry a passenger.● ALWAYS WEAR AN APPROVED MOTORCYCLE HELMET, eye protection, and protective clothing.
YAMAHA 3SL-2118K-00

⑦

TIRE INFORMATION
Cold tire normal pressure should be set as follows.
FRONT : 125 kPa, {1.25 kgf/cm ² }, 18 psi
REAR : 175 kPa, {1.75 kgf/cm ² }, 25 psi
YAMAHA 3SA-21668-01

DESCRIPTION

EAU00026

Left view

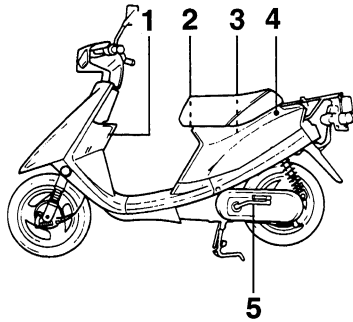

Right view

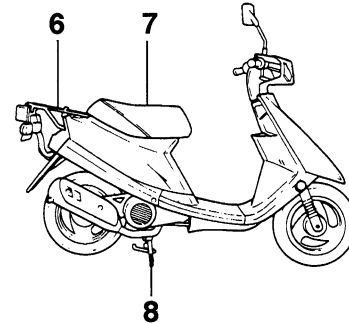

Controls/Instruments

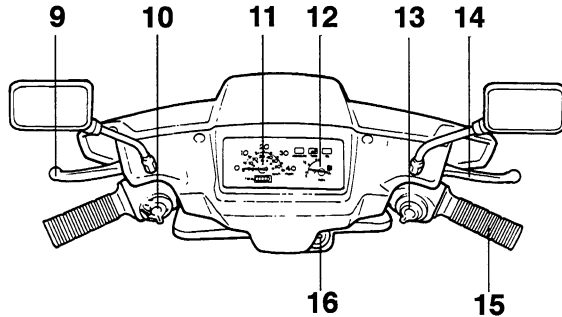

- 1. Front storage compartment
- 2. Helmet holder
- 3. Trunk
- 4. Seat lock
- 5. Kick starter
- 6. Rear carrier
- 7. Seat
- 8. Centerstand

- 9. Rear brake lever
- 10. Left handlebar switches
- 11. Speedometer
- 12. Fuel gauge
- 13. Right handlebar switches
- 14. Front brake lever
- 15. Throttle grip
- 16. Main switch

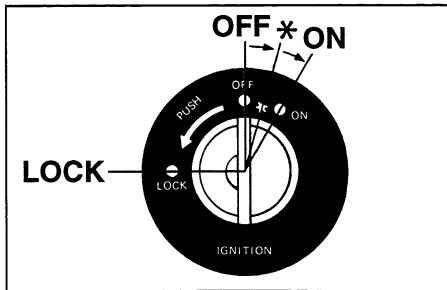

EAU00029

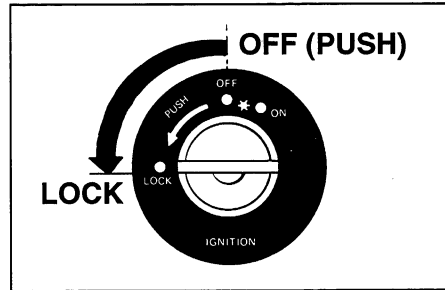

EAU00038

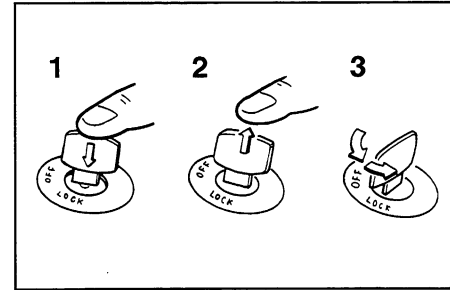

Main switch/Steering lock

The main switch controls the ignition and lighting systems. Its operation is described below.

EAU00034

ON:

Electrical circuits are switched on and the taillight comes on. The engine can be started. The key cannot be removed in this position.

NOTE:

When the engine is started, the headlight and meter lights come on automatically.

OFF:

All electrical circuits are switched off. The key can be removed in this position.

* :

The oil level indicator light will come on. For details of the oil level indicator light, refer to "Oil level indicator light" on page 3-3.

LOCK:

The steering is locked in this position and all electrical circuits are switched off. The key can be removed in this position. To lock the steering, turn the handlebars all the way to the left.

1. Push
2. Release
3. Turn

With the key at "OFF", push it into the main switch and release it, turn it counterclockwise to "LOCK" and remove it. To release the lock, turn the key to "OFF".

EW000016

! WARNING

Never turn the key to "OFF" or "LOCK" when the scooter is moving. The electrical circuits will be switched off which may result in loss of control or an accident. Be sure the scooter is stopped before turning the key to "OFF" or "LOCK".

INSTRUMENT AND CONTROL FUNCTIONS

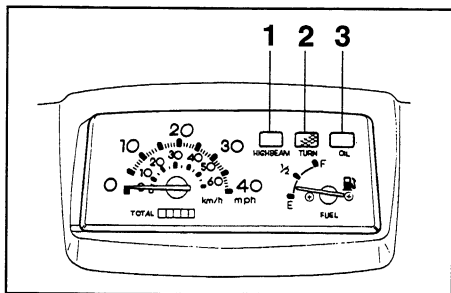

1. High beam indicator light "HIGH BEAM"
2. Turn indicator light "TURN"
3. Oil level indicator light "OIL"

EAU00056

Indicator lights

EAU00064

High beam indicator light "HIGH BEAM"

This indicator comes on when the headlight high beam is used.

EAU00059

Turn indicator light "TURN"

This indicator flashes when the turn switch is moved to the left or right.

EAU01488

Oil level indicator light "OIL"

The light comes on when the main switch is at "✱" or when there is little oil in the oil tank during operation. If the oil level indicator light comes on during operation, refill the tank immediately with Yamalube 2-cycle engine oil or 2-stroke engine oil. When the tank is refilled, the indicator light will go off.

If the oil level indicator light does not come on while the key is at "✱", have a Yamaha dealer inspect it.

EC000000

CAUTION:

Do not run the scooter until you know it has sufficient engine oil.

Oil level indicator light circuit check

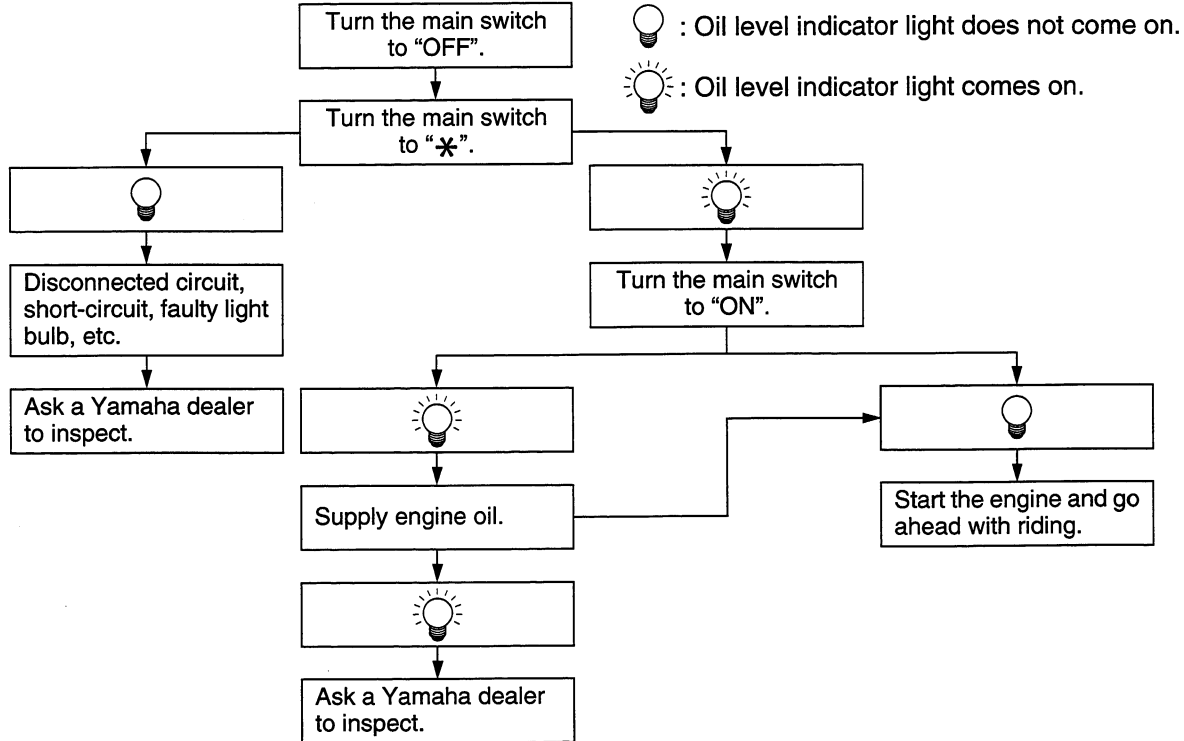

INSTRUMENT AND CONTROL FUNCTIONS

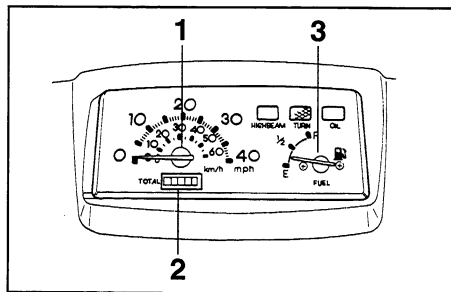

1. Speedometer
2. Odometer
3. Fuel gauge

Speedometer

EAU00098

The speedometer shows riding speed. This speedometer is equipped with an odometer.

EAU00113

Fuel gauge

The fuel gauge indicates the quantity of the remaining gasoline in the tank. The gauge needle moves from “F” (Full) to “E” (Empty) as the fuel level decreases. When the needle moves to the “E” position, add fuel as soon as possible.

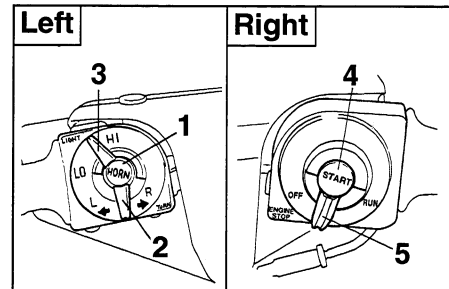

1. Horn switch “HORN”
2. Turn signal switch “TURN”
3. Dimmer switch “LIGHTS”
4. Start switch “START”
5. Engine stop switch “ENGINE STOP”

EAU00118

Handlebar switches

EAU00122

Dimmer switch “LIGHTS”

Turn the switch to “HI” for the high beam and to “LO” for the low beam.

EAU00128

Turn signal switch “TURN”

This is a three-position switch. The center position is off. Turn to “L” to turn on the left flasher, and to “R” for the right flasher. Be sure to turn the switch off after completing a turn.

INSTRUMENT AND CONTROL FUNCTIONS

Horn switch “HORN”

Press the switch to sound the horn.

EAU00130

Engine stop switch “ENGINE STOP”

The engine stop switch is a safety device for use in an emergency such as when the scooter overturns or if trouble occurs in the throttle system. Turn the switch to “RUN” to start the engine. In case of emergency, turn the switch to “OFF” to stop the engine.

EAU00137

EAU00142

Start switch “START”

The starter motor cranks the engine when pushing the start switch while applying the front or rear brake.

EC000005

CAUTION:

See starting instructions prior to starting the engine.

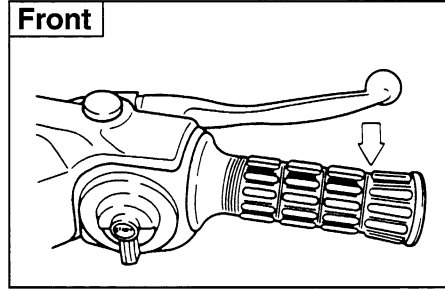

EAU00158

Front brake lever

The front brake lever is located on the right handlebar. Pull it toward the handlebar to apply the front brake.

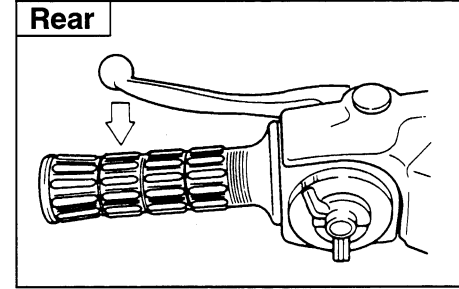

EAU00163

Rear brake lever

The rear brake lever is located on the left handlebar. Pull it toward the handlebar to apply the rear brake.

INSTRUMENT AND CONTROL FUNCTIONS

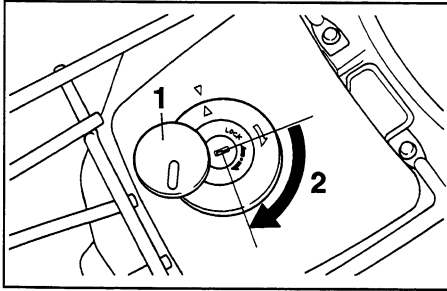

1. Cover
2. Open

EAU00173

Fuel tank cap

TO OPEN:

Slide the cover open. Insert the key and turn it 1/4 turn clockwise. The lock will be released and the cap can be opened.

TO CLOSE:

Align the match marks and push the tank cap into position with the key inserted. To remove the key, turn it counterclockwise to the original position. Close the cover.

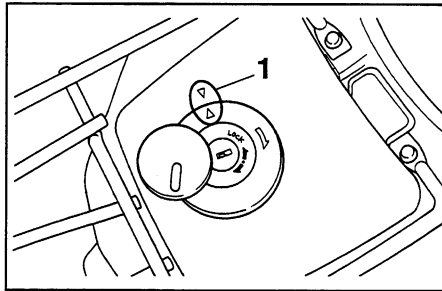

1. Match marks

NOTE:

This tank cap cannot be closed unless the key is in the lock. The key cannot be removed if the cap is not locked properly.

EW000023



WARNING

Be sure the cap is properly installed and locked in place before riding the scooter.

INSTRUMENT AND CONTROL FUNCTIONS

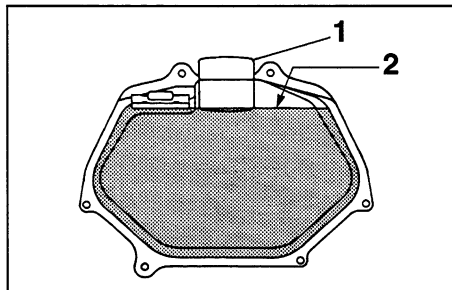

1. Filler tube
2. Fuel level

EAU01183

Fuel

Make sure there is sufficient fuel in the tank. Fill the fuel tank to the bottom of the filler tube as shown in the illustration.

EW000130

WARNING

Do not overfill the fuel tank. Avoid spilling fuel on the hot engine. Do not fill the fuel tank above the bottom of the filler tube or it may overflow when the fuel heats up later and expands.

EAU00185

CAUTION:

Always wipe off spilled fuel immediately with a dry and clean soft cloth. Fuel may deteriorate painted surfaces or plastic parts.

EAU00189*

Recommended fuel:
UNLEADED FUEL

Fuel tank capacity:

Total:

3.5 L (0.77 Imp gal, 0.93 US gal)

Your Yamaha engine has been designed to use regular unleaded gasoline with a pump octane number $([R+M]/2)$ of 86 or higher, or research octane number of 91 or higher. If knocking or pinging occurs, use a different brand of gasoline or premium unleaded fuel. Unleaded fuel will give you longer spark plug life and reduced maintenance cost. If unleaded gasoline is not available, then leaded regular gasoline can be used.

Gasohol

There are two types of gasohol; gasohol containing ethanol and that containing methanol. Gasohol containing ethanol can be used if ethanol content does not exceed 10%. Gasohol containing methanol is not recommended by Yamaha because it can cause fuel system damage or vehicle performance problems.

INSTRUMENT AND CONTROL FUNCTIONS

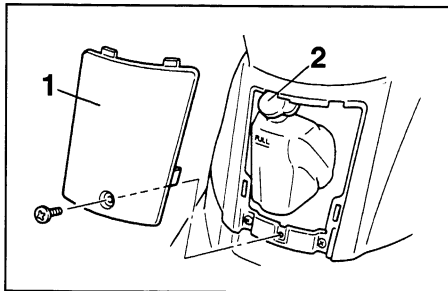

1. Front cover
2. Oil tank cap

EAU01489

Engine oil

Remove the front cover and check the oil level. If necessary, remove the cap and fill with the specified oil to the maximum mark. Then replace the cap.

Recommended oil:

Yamalube 2-cycle oil or 2-stroke engine oil

Oil quantity:

Total amount

0.8 L (0.70 Imp qt, 0.85 US qt)

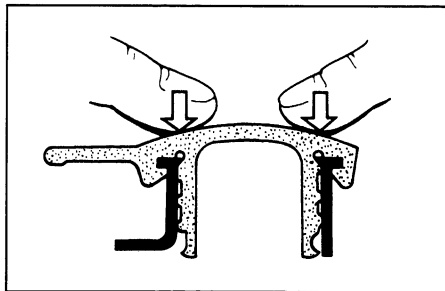

NOTE:

Be sure the cap is properly seated when replacing.

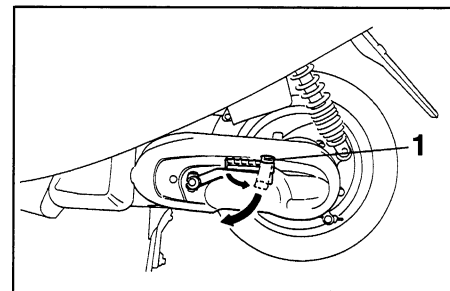

1. Kick starter

EAU00214

Kick starter

Rotate the kick starter away from the engine. Push the starter down lightly with your foot until the gears engage, then kick smoothly and forcefully to start the engine.

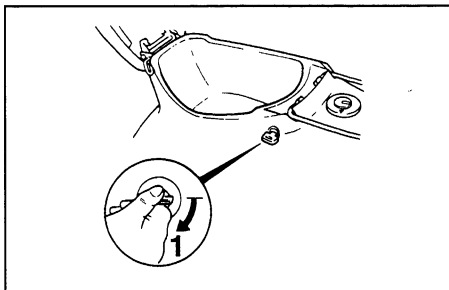

1. Open

EAU00234

Seat

To open the seat:

1. Insert the key in the lock and turn it as shown.
2. Lift the end of the seat up to open.

To lock the seat:

1. Replace the seat in the original position.
2. Slightly push the end of the seat down to lock.

NOTE: _____

Lift the end of the seat up to make sure the seat is securely locked.

Make sure the key is not in the trunk when locking the seat.

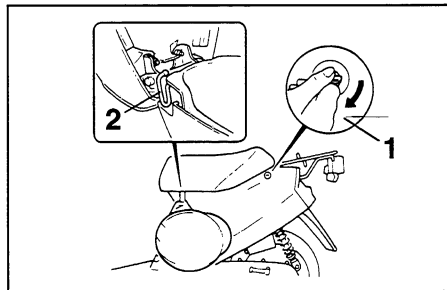

1. Open
2. Helmet holder

EAU00262

Helmet holder

The helmet holder is located under the seat. Open the seat and hook the helmet on the helmet holder. Then lock the seat.

EW000030



WARNING _____
Never ride with a helmet in the helmet holder. The helmet may hit objects, causing loss of control and possibly an accident.

INSTRUMENT AND CONTROL FUNCTIONS

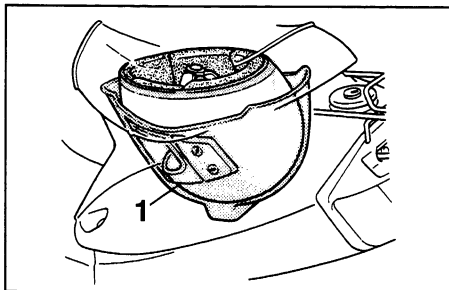

1. Trunk

EAU00268

Trunk

The trunk is under the seat.

EW000032

! WARNING

Do not exceed the load limit of 5 kg (11 lbs).

EC000010

CAUTION

Keep the following in mind when using the trunk.

1. The trunk gets hot inside when exposed to the sun. Do not put anything in the trunk susceptible to heat.

2. Put wet articles in a vinyl bag when storing them in the trunk.
3. The trunk may get wet while the scooter is being washed. Put articles in a vinyl bag before storing them in the trunk.
4. Do not put anything in the trunk that is valuable or easy to break.

When storing a helmet in the trunk, place it upside-down with the front facing forward.

NOTE:

- Some helmets cannot be stored in the trunk because of their size or shape.
- Do not leave your scooter with the seat open.

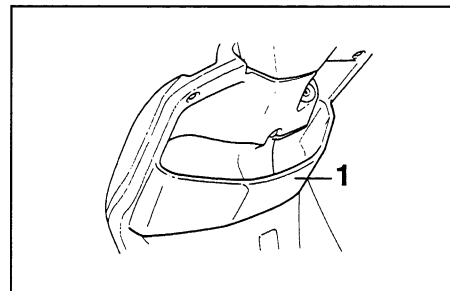

1. Front storage compartment

EAU01490

Storage compartment

EWA00004

! WARNING

Do not exceed the load limit of 1.5 kg (3 lbs).

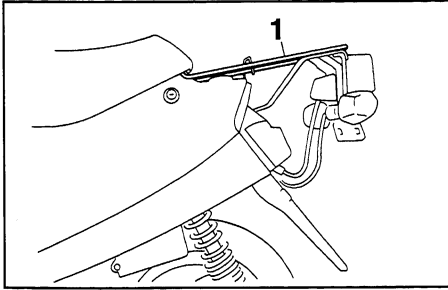

1. Rear carrier

EAU00320

Rear carrier

EW000032

WARNING

**Do not exceed the load limit of 3 kg
(7 lbs).**

PRE-OPERATION CHECKS

EAU01114

Owners are personally responsible for their vehicle's condition. Your scooter's vital functions can start to deteriorate quickly and unexpectedly, even if it remains unused (for instance, if it is exposed to the elements). Any damage, fluid leak or loss of tire pressure could have serious consequences. Therefore, it is very important that, in addition to a thorough visual inspection, you check the following points before each ride.

PRE-OPERATION CHECK LIST

EAU00340

ITEM	ROUTINE	PAGE
Front and rear brakes	<ul style="list-style-type: none">• Check operation, condition and free play.• Adjust if necessary.	6-10
Throttle grip and housing	<ul style="list-style-type: none">• Check for smooth operation.• Lubricate if necessary.	6-7
Engine oil	<ul style="list-style-type: none">• Check oil level.• Fill with oil if necessary.	3-8
Wheels and tires	<ul style="list-style-type: none">• Check tire pressure, wear and damage.	6-8 ~ 6-9
Control and meter cable	<ul style="list-style-type: none">• Check for smooth operation.• Lubricate if necessary.	-
Brake lever pivots	<ul style="list-style-type: none">• Check for smooth operation.• Lubricate if necessary.	-
Centerstand pivot	<ul style="list-style-type: none">• Check for smooth operation.• Lubricate if necessary.	-
Chassis fasteners	<ul style="list-style-type: none">• Make sure that all nuts, bolts and screws are properly tightened.• Tighten if necessary.	-
Fuel tank	<ul style="list-style-type: none">• Check fuel level.• Fill with fuel if necessary.	3-7
Lights, signals and switches	<ul style="list-style-type: none">• Check for proper operation.	-

PRE-OPERATION CHECKS

NOTE:

Pre-operation checks should be made each time the scooter is used. Such an inspection can be thoroughly accomplished in a very short time, and the added safety it assures is more than worth the time involved.

WARNING

1. The engine, exhaust pipe, and muffler will be very hot after the engine has been run. Be careful not to touch them or to allow any clothing item to contact them during inspection or repair.
 2. If any item in the PRE-OPERATION CHECK is not working properly, have it inspected and repaired before operating the scooter. If necessary ask a Yamaha dealer.
-

OPERATION AND IMPORTANT RIDING POINTS

EAU00372

EAU01118

⚠ WARNING

1. Before riding this scooter, become thoroughly familiar with all operating controls and their functions. Consult a Yamaha dealer regarding any control or function that you do not thoroughly understand.
2. Never start your engine or let it run for any length of time in a closed area. The exhaust fumes are poisonous and can cause loss of consciousness and death within a short time. Always operate your scooter in an area with adequate ventilation.
3. For safety, be sure to start the engine with the centerstand down.

CAUTION:

1. Be careful where you store personal items on the scooter. Avoid blocking the air cleaner intake or performance will suffer.
2. Be careful not to put anything near the battery and its terminals. Electrical failure and acid corrosion may result.

EAU00376

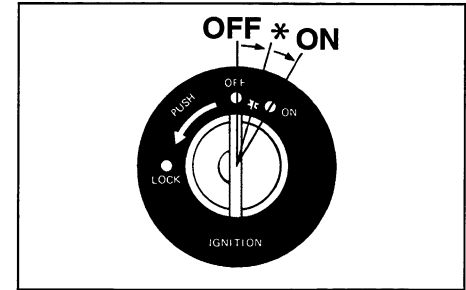

EAU00414

Starting and warming up a cold engine

1. Turn the engine stop switch to "RUN".
2. Turn the main switch to " * ". If the oil level indicator light comes on, turn the main switch to "ON".

EC000045

CAUTION:

If the oil level indicator light does not come on, ask a Yamaha dealer to inspect it.

OPERATION AND IMPORTANT RIDING POINTS

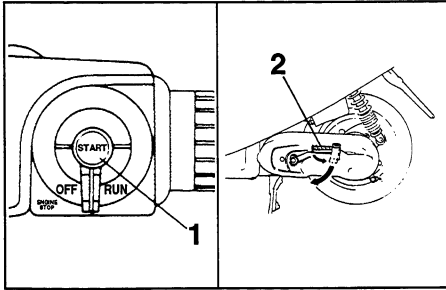

1. Start switch "START"
2. Kick starter

3. Completely close the throttle grip and start the engine by pushing the start switch while applying the front or rear brake or by kicking the kick starter.

NOTE:

If the engine fails to start, release the start switch, wait a few seconds, then try again. Each attempt should be as short as possible to preserve the battery. Do not crank the engine more than 5 seconds on any one attempt. If the engine does not start with the starter motor, kick the kick starter to start the engine.

NOTE:

For maximum engine life, always warm up the engine about 1 ~ 3 minutes before riding your scooter. Never accelerate hard with a cold engine.

EC000046

CAUTION

See the "Engine break-in" section prior to operating the scooter for the first time.

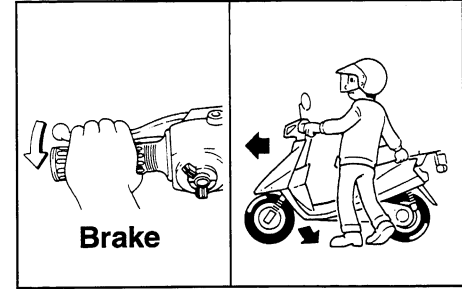

EAU00433

Starting off

After warming up the engine:

1. Apply the rear brake lever with your left hand and hold the grab bar with your right hand. Then push the scooter off the centerstand.
2. Sit astride the seat and adjust the rear view mirrors.
3. Check the oncoming traffic and use a turn signal.
4. Turn the throttle grip on the right handlebar slowly and you will start off. Remember to turn off the turn signal.

OPERATION AND IMPORTANT RIDING POINTS

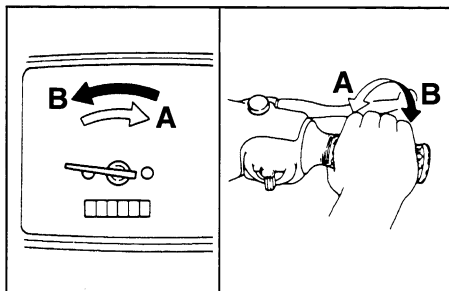

EAU00434

Acceleration

The speed can be adjusted by opening and closing the throttle grip. Turning it toward you increases the speed, and turning it in the opposite direction decreases the speed.

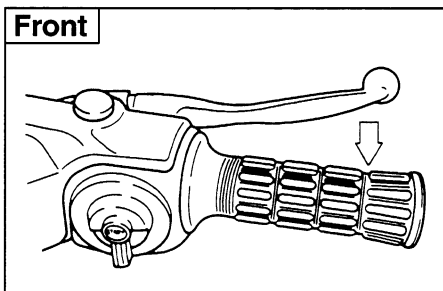

EAU00435

Braking

1. Close the throttle grip.
2. Apply both front and rear brakes simultaneously with light pressure and increase the pressure slowly.

EW000057

⚠ WARNING

1. **Avoid hard or sudden braking. It may cause the scooter to skid or overturn.**
2. **Be sure to apply the brake carefully if leaning over to one side. Improper braking could lead to a skid.**

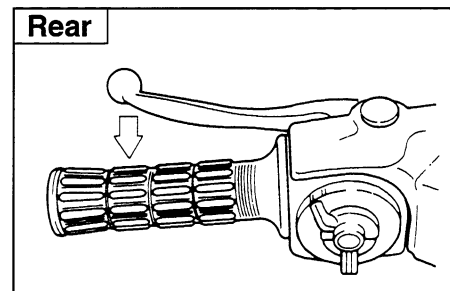

3. **Street car rails, metal plates on road construction sites, and man-hole covers become particularly slippery when they get wet. Cross them slowly and cautiously.**

4. **Braking on a wet road is very difficult.**
5. **Braking on a hill can be difficult. Proceed slowly when riding downhill.**

OPERATION AND IMPORTANT RIDING POINTS

EAU00436

Engine break-in

There is never a more important period in the life of your scooter than the period between zero and 1,000 km (600 mi). For this reason we ask that you carefully read the following material. Because the engine is brand new, you must not put an excessive load on it for the first 1,000 km (600 mi). The various parts in the engine wear and polish themselves to the correct operating clearances. During this period, prolonged full throttle operation, or any condition which might result in excessive heating of the engine, must be avoided.

EAU00456

1. 0 ~ 150 km (0 ~ 90 mi):
Avoid operation above 1/3 throttle. Stop the engine and let it cool for 5 to 10 minutes after every hour of operation. Vary the speed of the scooter from time to time. Do not operate it at one set throttle position.
2. 150 ~ 500 km (90 ~ 300 mi):
Avoid prolonged operation above 1/2 throttle.

EC000061

CAUTION:

After 500 km (300 mi) of operation, be sure to replace the transmission oil.

3. 500 ~ 1,000 km (300 ~ 600 mi):
Avoid cruising speeds in excess of 3/4 throttle.
4. 1,000 km (600 mi) and beyond:
Avoid prolonged full throttle operation. Vary speeds occasionally.

EC000049

CAUTION:

If any engine trouble should occur during the break-in period, consult a Yamaha dealer immediately.

OPERATION AND IMPORTANT RIDING POINTS

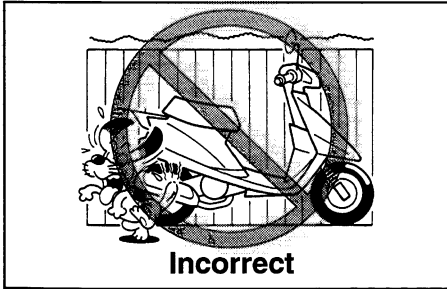

EAU00460

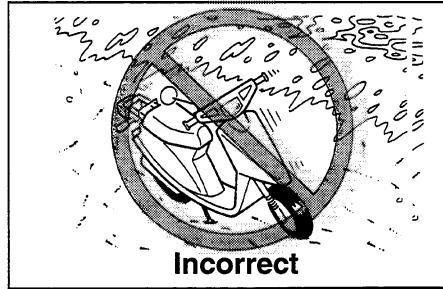

EW000058

Parking

When parking the scooter, stop the engine and remove the ignition key.

WARNING

The exhaust system is hot. Park the scooter in a place where pedestrians or children are not likely to touch the scooter. Do not park the scooter on a slope or soft ground; the scooter may overturn.

EAU00465

Periodic inspection, adjustment, and lubrication will keep your scooter in the safest and most efficient condition possible. Safety is an obligation of the scooter owner. The maintenance and lubrication schedule chart should be considered strictly as a guide to general maintenance and lubrication intervals. **YOU MUST TAKE INTO CONSIDERATION THAT WEATHER, TERRAIN, GEOGRAPHICAL LOCATIONS, AND A VARIETY OF INDIVIDUAL USES ALL TEND TO DEMAND THAT EACH OWNER ALTER THIS TIME SCHEDULE TO SHORTER INTERVALS TO MATCH THE ENVIRONMENT.** The most important points of scooter inspection, adjustment and lubrication are explained in the following pages.

EW000060

⚠ WARNING

If you are not familiar with scooter service, this work should be done by a Yamaha dealer.

EAU00466

CAUTION:

This scooter is designed for use on paved road surface only. If this scooter is operated in abnormally dusty, muddy or wet conditions, the air filter should be cleaned or replaced more frequently. Otherwise, rapid engine wear may result. Consult a Yamaha dealer for proper maintenance intervals.

PERIODIC MAINTENANCE AND MINOR REPAIR

EAU00473

PERIODIC MAINTENANCE AND LUBRICATION

NO.	ITEM	ROUTINE	BREAK-IN 500km (300 mi)	EVERY	
				3,000 km (2,000 mi) or 6 months	6,000 km (4,000 mi) or 12 months
1	Spark plug	<ul style="list-style-type: none"> • Check condition. • Clean or replace if necessary. 	√	√	√
2	Air filter	<ul style="list-style-type: none"> • Clean. • Replace if necessary. 		√	√
3	* Carburetor	<ul style="list-style-type: none"> • Check idle speed. • Adjust if necessary. 	√		√
4	* Fuel line	<ul style="list-style-type: none"> • Check fuel hose and vacuum pipe for cracks or damage. • Replace if necessary. 		√	√
5	* Transmission oil	<ul style="list-style-type: none"> • Check oil leakage. • Correct if necessary. • Replace every 12,000 km (8,000 mi) or 24 months. (Warm engine before draining.) 	REPLACE	√	√
6	* Autolube pump	<ul style="list-style-type: none"> • Check operation. • Correct if necessary. • Bleed the air. 	√		√
7	Brakes	<ul style="list-style-type: none"> • Check operation. • Adjust if necessary. 		√	√
8	* Wheels	<ul style="list-style-type: none"> • Check damage/runout. • Replace if necessary. 		√	√
9	* Wheel bearings	<ul style="list-style-type: none"> • Check bearing assembly for looseness/damage. • Replace if damaged. 		√	√
10	* Steering bearings	<ul style="list-style-type: none"> • Check bearing assembly for looseness. • Correct if necessary. • Moderately repack every 12,000 km (8,000 mi) or 24 months.** 	√	√	√
11	* Rear shock absorber	<ul style="list-style-type: none"> • Check operation/oil leakage. • Repair if necessary. 		√	√

PERIODIC MAINTENANCE AND MINOR REPAIR

NO.	ITEM	ROUTINE	BREAK-IN 500km (300 mi)	EVERY	
				3,000 km (2,000 mi) or 6 months	6,000 km (4,000 mi) or 12 months
12 *	V-belt	<ul style="list-style-type: none"> • Check damage and wear. • Replace if necessary. 			√
13 *	Fittings and fasteners	<ul style="list-style-type: none"> • Check all chassis fittings and fasteners. • Tighten if necessary. 	√	√	√
14 *	Centerstand	<ul style="list-style-type: none"> • Check operation. • Repair if necessary. 	√	√	√

* Since these items require special tools, data and technical skills, they should be serviced by a Yamaha dealer.

** Medium weight wheel bearing grease.

EAU00479

NOTE: _____

The air filter needs more frequent service if you are riding in unusually wet or dusty areas.

PERIODIC MAINTENANCE AND MINOR REPAIR

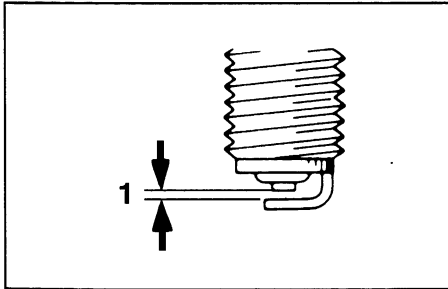

1. Spark plug gap

EAU00495

Spark plug inspection

The spark plug is an important engine component and is easy to inspect. The condition of the spark plug can indicate the condition of the engine. The ideal color on the white insulator around the center electrode is a medium-to-light tan color for a scooter that is being ridden normally. Do not attempt to diagnose any problems yourself. Instead, take the scooter to a Yamaha dealer. You should periodically remove and inspect the spark plug because heat and deposits will cause the spark plug to slowly break down and erode. If electrode erosion becomes excessive, or if

carbon and other deposits are excessive, you should replace the spark plug with the specified plug.

Specified spark plug:
BR7HS (NGK)

Before installing the spark plug, measure the electrode gap with a wire thickness gauge; adjust the gap to specification as necessary.

Spark plug gap:
0.5 ~ 0.6 mm (0.020 ~ 0.024 in)

When installing the plug, always clean the gasket surface and use a new gasket. Wipe off any grime from the threads and tighten the spark plug to the specified torque.

Tightening torque:
Spark plug:
20 Nm (2.0 m·kg, 14 ft·lb)

NOTE: _____
If a torque wrench is not available when you are installing a spark plug, a good estimate of the correct torque is 1/4 to 1/2 turn past finger tight. Have the spark plug tightened to the specified torque as soon as possible.

PERIODIC MAINTENANCE AND MINOR REPAIR

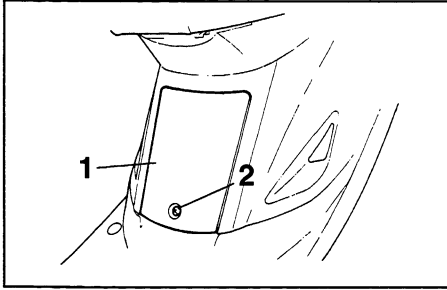

1. Front cover
2. Screw

EAU01491

Air filter element cleaning

This air filter should be cleaned at the specified intervals. It should be cleaned more frequently you are riding in unusually wet or dusty areas.

1. Remove the front cover.

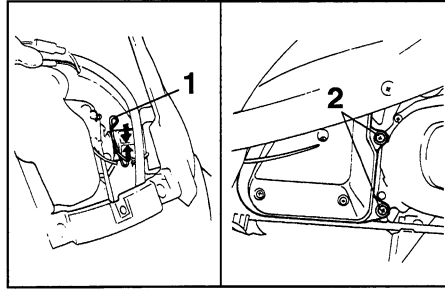

1. Clamp
2. Screw (x 2)

2. Remove the air filter case assembly by removing the clamp and screws.

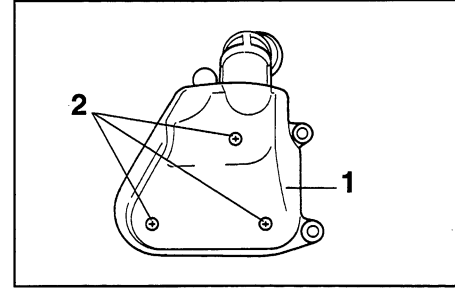

1. Air filter case cover
2. Screw (x 3)

3. Remove the air filter case cover by removing the screws.

PERIODIC MAINTENANCE AND MINOR REPAIR

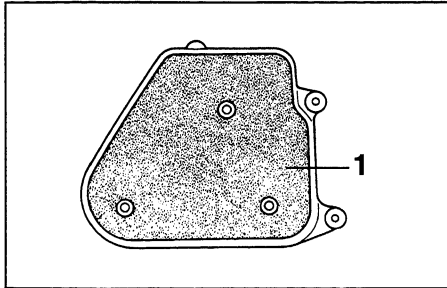

1. Air filter

4. Remove the air filter from its case. Wash the air filter gently, but thoroughly, in solvent.

EW000075

WARNING

Use parts cleaning solvent only. Never use gasoline or low flash point solvents which may lead to a fire or explosion.

5. Squeeze the excess solvent out of the air filter and let it dry.

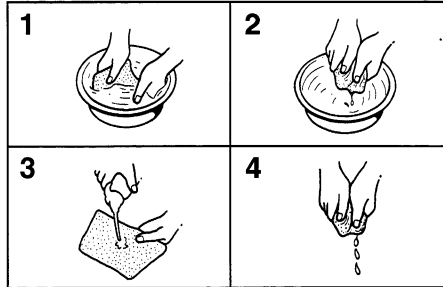

EC000090

CAUTION:

Do not twist or wring out the air filter element. This could damage the foam material.

6. Apply oil to the entire surface of the air filter and squeeze out the excess oil. It should be damp, but not dripping with oil.

Recommended oil:

Yamalube 2-cycle oil or 2-stroke engine oil

7. Install the air filter in its case. Be sure the sealing edge of the air filter perfectly matches with the sealing surface of its case so there is no air leakage.
8. Install the air filter case cover. Be sure that the seal is in place and that the bolts are tightened securely to avoid the possibility of unfiltered air entering the engine.

EC000084

CAUTION:

The engine should never be run without the air filter element installed; excessive piston and/or cylinder wear may result.

PERIODIC MAINTENANCE AND MINOR REPAIR

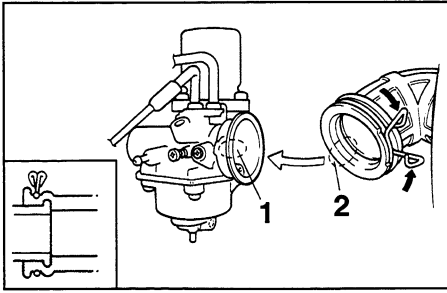

1. Carburetor projection
2. Air filter joint slot

9. Install the air filter case assembly.

NOTE:

Align the carburetor projection with air filter joint slot.

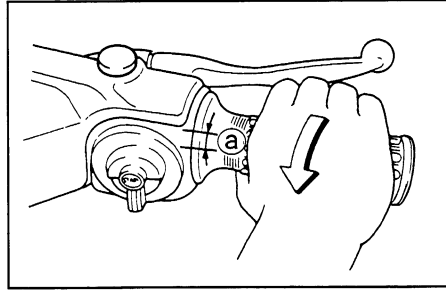

- a. Free play

EAU00635

Throttle cable free play inspection

There should be a free play of 1.5 ~ 3.5 mm (0.06 ~ 0.14 in) at the throttle grip. If the free play is incorrect, ask a Yamaha dealer to make this adjustment.

PERIODIC MAINTENANCE AND MINOR REPAIR

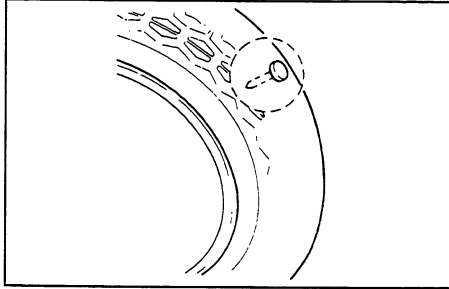

EAU00672*

Tires

Check both front and rear tire pressures. Also check for nails, fragments of glass, or stones embedded in the tire treads. Check the run-out of each tire rim, and recondition as necessary. Ask a Yamaha dealer, if required.

EW000089

! WARNING

1. Proper loading is important for several characteristics of your scooter; such as handling, braking, performance and safety. **NEVER OVERLOAD YOUR SCOOTER.** Make sure the total weight of the cargo, rider, and accessories (fairing, saddlebags, etc. if approved for this model) does not exceed the maximum load of the scooter. Operation of an overloaded scooter could cause tire damage, an accident, or even injury.

2. Improper tire pressure greatly affects tire life and handling. Check the pressure of both tires prior to each trip and adjust properly if necessary. If tire pressure is too high, shocks from the road will not be damped and will be carried to the frame and handlebars, thus adversely affecting riding comfort. In addition, scooter stability will be poor when making a turn. If tire pressure is too low, tires will be deformed greatly, thus shortening tire life. When braking, the tires could slip over the wheel rims and the tubes could be damaged. Also, when turning a corner or going around a curve, the scooter could easily turn over.

PERIODIC MAINTENANCE AND MINOR REPAIR

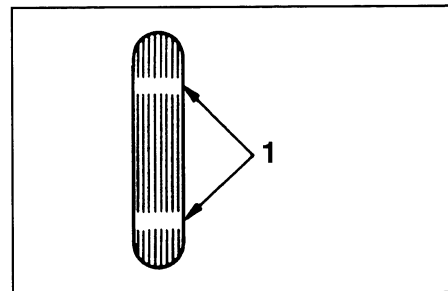
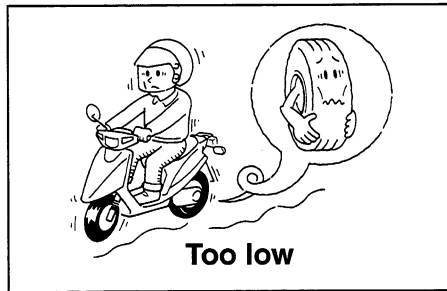
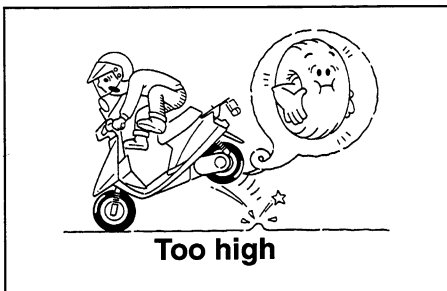

Cold tire pressure:

Front:

125 kPa (1.25 kgf/cm², 18 psi)

Rear:

175 kPa (1.75 kgf/cm², 25 psi)

Maximum loading limit*:

75 kg (165 lb)

* Load is the total weight of cargo, rider and accessories.

If tire treads are excessively worn, the scooter tends to slip or skid on wet roads or even on paved roads covered with dirt. If a tread depth shows cross-wise lines, it means that the tire is worn to its limit. Replace the tire.

1. Wear indicator

Minimum tire tread depth (front and rear)	1.0 mm (0.04 in)
--	------------------

EAU00682

⚠ WARNING

It is dangerous to ride with a worn-out tire. When a tire tread begins to show lines, have a Yamaha dealer replace the tire immediately. Brakes, tires and related wheel parts replacement should also be left to a Yamaha dealer.

PERIODIC MAINTENANCE AND MINOR REPAIR

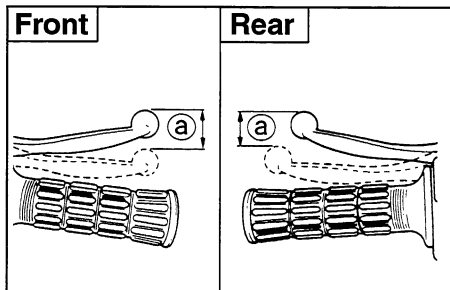

a. Free play

EAU00702

Front and rear brake lever free play adjustment

The front and rear brake lever free play should be adjusted to 10 ~ 20 mm (0.4 ~ 0.8 in) at the brake lever end.

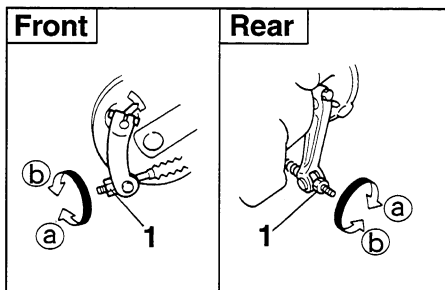

1. Adjusting nut

Make adjustment at the corresponding brake hub. Turn the adjusting nut in direction Ⓐ to increase free play and in direction Ⓑ to decrease free play.

EW000101



WARNING

When it is impossible to make the proper adjustment, ask a Yamaha dealer.

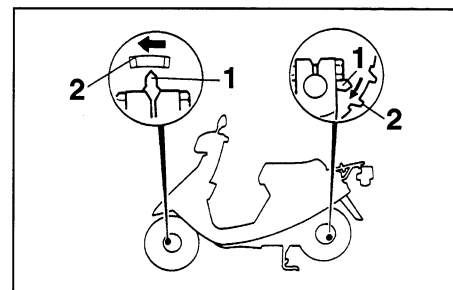

1. Wear indicator

2. Wear limit

EAU00719

Checking the brake shoes

A wear indicator is provided on each brake. This indicator allows inspection of shoe wear without disassembling the brake. Apply the brake and inspect the position of the indicator. If the indicator reaches to the wear limit line, ask a Yamaha dealer to replace the shoes.

PERIODIC MAINTENANCE AND MINOR REPAIR

EAU00800

EW000116

Battery

This scooter is equipped with a sealed-type battery. Therefore it is not necessary to check the electrolyte or fill the battery with distilled water.

- If the battery seems to have discharged, consult a Yamaha dealer.
- If the scooter is equipped with optional electrical accessories, the battery tends to discharge more quickly, so be sure to recharge it periodically.

EC000101

CAUTION:

Never try to remove the sealing caps of the battery cells. The battery will be damaged.

WARNING

Battery electrolyte is poisonous and dangerous, causing severe burns, etc. It contains sulfuric acid. Avoid contact with skin, eyes or clothing.

Antidote:

EXTERNAL: Flush with water.

INTERNAL: Drink large quantities of water or milk. Follow with milk of magnesia, beaten egg, or vegetable oil. Call a physician immediately.

EYES: Flush with water for 15 minutes and get prompt medical attention. Batteries produce explosive gases. Keep sparks, flame, cigarettes etc., away. Ventilate when charging or using in an enclosed space. Always shield your eyes when working near batteries.

KEEP OUT OF REACH OF CHILDREN.

Battery storage

When the scooter is not used for a month or longer, remove the battery, fully charge it and store it in a cool, dry place.

EC000102

CAUTION:

- Completely recharge the battery before storing. Storing a discharged battery can cause permanent battery damage.
- Use a battery charger designed for a sealed-type (MF) battery. Using a conventional battery charger will cause battery damage. If you do not have a sealed-type battery charger, contact your Yamaha dealer.
- Always make sure the connections are correct when reinstalling the battery.

PERIODIC MAINTENANCE AND MINOR REPAIR

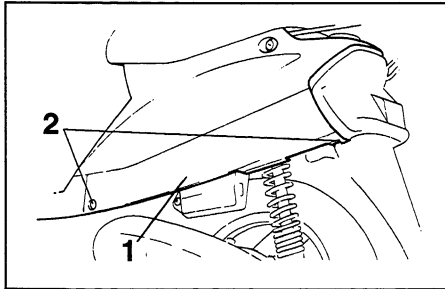

1. Left side panel
2. Screw (× 2)

EAU00809

Fuse replacement

1. Remove the left side panel.

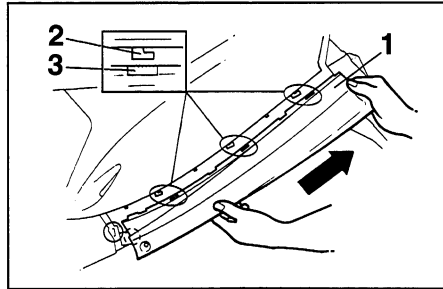

1. Left side panel
2. Catch
3. Slot

NOTE:

Pull the front of the left side panel outward and slide it backward to unhook the slots on the side panel from the catches on the tail cowl.

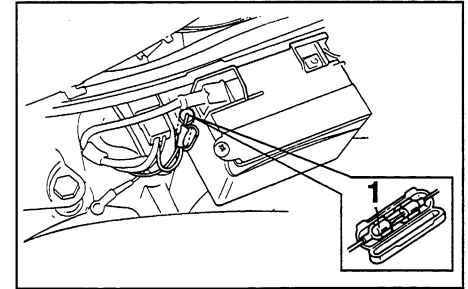

1. Main fuse
2. The fuse case is located beside the battery box.
3. If a fuse is blown, turn off the ignition switch and the switch of the circuit in question. Install a new fuse of specified amperage. Turn on the switches, and see if the electrical device operates. If the fuse immediately blows again, consult a Yamaha dealer.

EC000103

EAU01008

CAUTION

Do not use fuses of higher amperage rating than those recommended. Substitution of a fuse of improper rating can cause extensive electrical system damage and possibly a fire.

Specified fuse: 7 A

Troubleshooting

Although Yamaha scooters receive a rigid inspection before shipment from the factory, trouble may occur during operation.

Any problem in the fuel, compression, or ignition systems can cause poor starting and loss of power. The troubleshooting chart describes a quick, easy procedure for making checks.

If your scooter requires any repair, bring it to a Yamaha dealer. The skilled technicians at a Yamaha dealership have the tools, experience, and know-how to properly service your scooter. Use only genuine Yamaha parts on your scooter. Imitation parts may look like Yamaha parts, but they are often inferior. Consequently, they have a shorter service life and can lead to expensive repair bills.

PERIODIC MAINTENANCE AND MINOR REPAIR

EAU01397

Troubleshooting chart

EW000125



Never check the fuel system while smoking or in the vicinity of an open flame.

1. Fuel

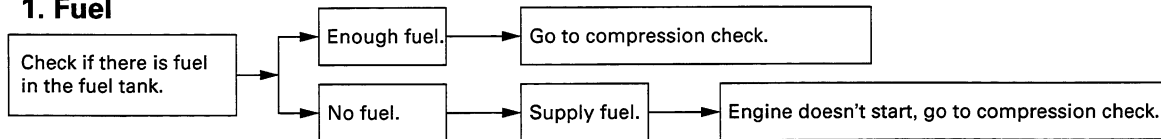

2. Compression

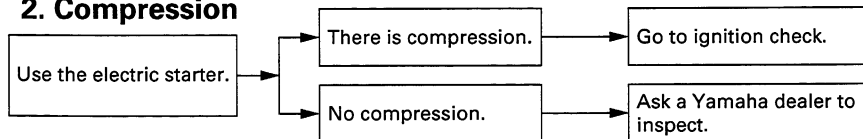

3. Ignition

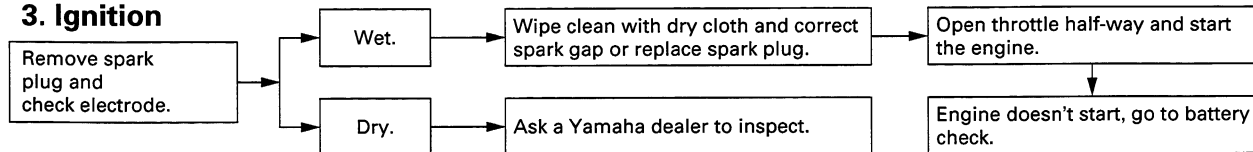

4. Battery

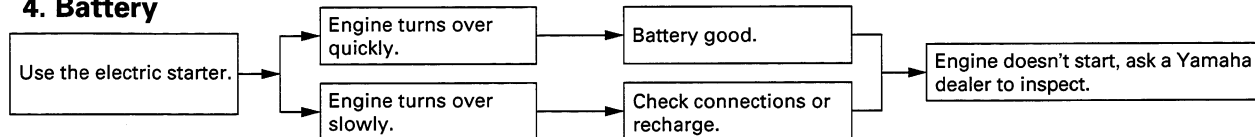

EAU01012

EC000111

A. CLEANING

Frequent, thorough cleaning of your scooter will not only enhance its appearance but will improve its general performance and extend the useful life of many components.

1. Before cleaning the scooter:
 - a. Block off the end of the exhaust pipe to prevent water entry; a plastic bag and strong rubber band may be used.
 - b. Make sure the spark plug and all filler caps are properly installed.
2. If the engine case is excessively greasy, apply degreaser with a paint brush. Do not apply degreaser to wheel axles.
3. Rinse the dirt and degreaser off with a garden hose. Use only enough pressure to do the job.

CAUTION:

Excessive hose pressure may cause water seepage and deterioration of wheel bearings, front fork, brakes, transmission seals and electrical parts.

Many expensive repair bills have resulted from improper high pressure detergent applications such as those available in coin-operated car washers.

4. After riding on salted roads, wash the scooter with cold water immediately. Do not use warm water as it increases the chemical reaction of the salt.
5. Once the majority of the dirt has been hosed off, wash all surfaces with warm water and mild, detergent-type soap. An old toothbrush or bottle brush is handy for hard-to-get-at places.

6. Rinse the scooter off immediately with clean water and dry all surfaces with a chamois, clean towel, or soft absorbent cloth.
7. Clean the seat with a vinyl upholstery cleaner to keep the cover pliable and glossy.
8. Automotive-type wax may be applied to all painted and chrome-plated surfaces. Avoid combination cleaner-waxes. Many contain abrasives which may mar the paint or protective finish. When finished, start the engine and let it idle for several minutes.

CLEANING AND STORAGE

EAU01024

B. STORAGE

Long term storage (60 days or more) of your scooter will require some preventive procedures to guard against deterioration. After thoroughly cleaning the scooter, prepare for storage as follows:

1. Fill the fuel tank with fuel and fuel stabilizer (if available).
2. Remove the spark plug, pour about one tablespoon of SAE 10W30 or 20W40 motor oil in the spark plug hole and reinstall the spark plug. Turn the engine over several times (with the ignition off) to coat the cylinder wall with oil.

EW000126

WARNING

When using the starter motor to crank the engine, remove the spark plug wire, and ground it to prevent sparking.

3. Lubricate all control cables.
4. Block up the frame to raise both wheels off the ground.

5. Tie a plastic bag over the exhaust pipe outlet to prevent moisture from entering.
6. If storing in a humid or salt-air atmosphere, coat all exposed metal surfaces with a light film of oil. Do not apply oil to any rubber parts or the seat cover.
7. Remove the battery and fully charge it. Store it in a cool, dry place and recharge it once a month. Do not store the battery in an excessively warm or cold place (less than 0°C (30°F) or more than 30°C (90°F)). See page 6-11 for battery storage precautions.

NOTE:

Make any necessary repairs before storing the scooter.

Specifications

Model	CY50		
Dimensions:			
Overall length	1,645 mm (64.8 in)		
Overall width	630 mm (24.8 in)		
Overall height	980 mm (38.6 in)		
Seat height	710 mm (28.0 in)		
Wheelbase	1,115 mm (43.9 in)		
Ground clearance	80 mm (3.1 in)		
Minimum turning radius	1,600 mm (63.0 in)		
Basic weight:			
With oil and full fuel tank	65 kg (143 lb)		
Engine:			
Engine type	Air-cooled 2-stroke		
Cylinder arrangement	Forward, inclined signal cylinder		
Displacement	49 cm ³		
Bore × stroke	40.0 × 39.2 mm (1.57 × 1.54 in)		
Compression ratio	7.2:1		
Starting system	Electric and kick starter		
Lubrication system	Separate lubrication (Yamaha autolube)		
Engine oil:			
Type	YAMALUBE 2-cycle oil or 2-stroke engine oil		
		Quantity:	
		Total amount	0.8 L (0.70 Imp qt, 0.85 US qt)
		Transmission oil:	
		Type	SAE10W30SE
		Quantity:	
		Periodic oil change	0.1 L (0.09 Imp qt, 0.11 US qt)
		Total amount	0.11 L (0.10 Imp qt, 0.12 US qt)
		Air filter	Wet type element
		Fuel:	
		Type	Unleaded fuel
		Fuel tank capacity	3.5 L (0.77 Imp gal, 0.93 US gal)
		Carburetor:	
		Type × quantity	Y14P × 1
		Manufacturer	TEIKEI
		Spark plug:	
		Type/Manufacturer	BR7HS/NGK
		Spark plug gap	0.5 ~ 0.6 mm (0.020 ~ 0.024 in)
		Clutch type	Dry, centrifugal automatic
		Transmission:	
		Primary reduction system	Helical gear
		Primary reduction ratio	3.692
		Secondary reduction system	Spur gear
		Secondary reduction ratio	3.000

SPECIFICATIONS

Transmission type	V-belt automatic
Operation	Centrifugal automatic type
Chassis:	
Frame type	Steel tube underbone
Caster angle	26.5°
Trail	72 mm (2.83 in)
Tire:	
Type	Tubeless
Size:	
Front	80/90-10 34J
Rear	80/90-10 34J
Manufacturer / model:	
Front	INOUE/MB38 CHENG SHIN/C-922
Rear	INOUE/MB38 CHENG SHIN/C-922
Tire pressure:	
Front	125 kPa; 1.25 kgf/cm ² ; 18 psi
Rear	175 kPa; 1.75 kgf/cm ² ; 25 psi
Wheels:	
Type:	
Front	Panel wheel
Rear	Panel wheel

Rim size:	
Front	J10 × 2.15
Rear	J10 × 2.15
Brakes:	
Front:	
Type	Drum brake
Operation	Right hand operation
Rear:	
Type	Drum brake
Operation	Left hand operation
Suspension:	
Front:	
Type	Telescopic fork
Rear:	
Type	Unit swing
Shock absorber:	
Front	Coil spring
Rear	Coil spring / oil damper
Wheel travel:	
Front	42 mm (1.65 in)
Rear	42 mm (1.65 in)

Electrical:

Ignition system	C.D.I.
Generator system	C.D.I. magneto
Battery:	
Type	YT4L-BS
Capacity	12 V, 3 AH
Headlight type	Sealed beam

Bulb voltage, wattage × quantity:

Headlight	12 V, 25 W / 25 W × 1
Tail / brake light	12 V, 21 W / 5 W × 1
Front flasher light	12 V, 10 W × 2
Rear flasher light	12 V, 10 W × 2
Meter light	12 V, 3.4 W × 1
High beam indicator light	12 V, 1.7 W × 1
Oil level indicator light	12 V, 3.4 × 1
Turn indicator light	12 V, 1.7 W × 1

Fuses:

Main	7 A
------	-----

EAU01040

Identification numbers record

Record the key identification number, vehicle identification number and model label information in the spaces provided for assistance when ordering spare parts from a Yamaha dealer or for reference in case the vehicle is stolen.

1. KEY IDENTIFICATION NUMBER:

2. VEHICLE IDENTIFICATION NUMBER:

3. MODEL LABEL INFORMATION:

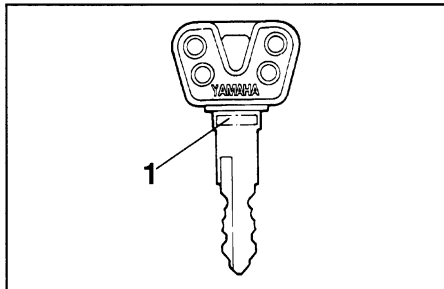

1. Key identification number

EAU01042

Key identification number

The key identification number is stamped on the key. Record this number in the space provided and use it for reference when obtaining a new key.

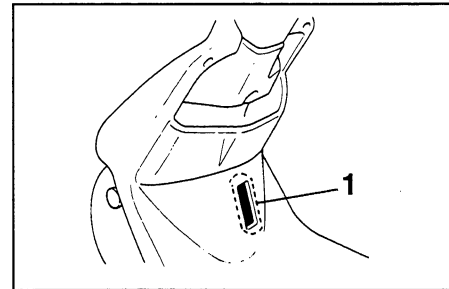

1. Vehicle identification number

EAU01044

Vehicle identification number

The vehicle identification number is stamped into the frame.

NOTE: _____

The vehicle identification number is used to identify your scooter and may be used to register your scooter with the licensing authority in your state.

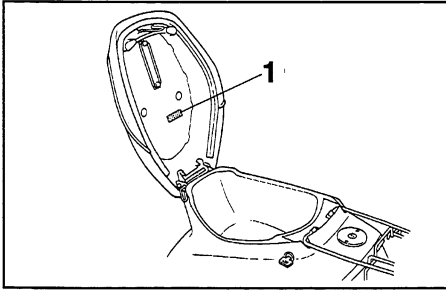

1. Model label

EAU01049

Model label

The model label is affixed to the location shown in the figure. Record the information on this label in the space provided. This information will be needed to order spare parts from your Yamaha dealer.

CONSUMER INFORMATION

EAU01051

Reporting safety defects

If you believe that your vehicle has a defect which could cause a crash or could cause injury or death, you should immediately inform the National Highway Traffic Safety Administration (NHTSA) in addition to notifying YAMAHA MOTOR CORP. U.S.A.. If NHTSA receives similar complaints, it may open an investigation, and if it finds that a safety defect exists in group of vehicles, it may order a recall and remedy campaign. However, NHTSA cannot become involved in individual problems between you, your dealer, or YAMAHA MOTOR CORP. U.S.A..

To contact NHTSA, you may either call the Auto Safety Hotline toll-free at 1-800-424-9393 (or 366-0123 in Washington, D.C. area) or write to: NHTSA, U.S. Department of Transportation, Washington, D.C. 20590. You can also obtain other information about motor vehicle safety from the Hotline.

Scooter noise regulation

TAMPERING WITH NOISE CONTROL SYSTEM PROHIBITED:

Federal law prohibits the following acts or the causing thereof: (1) The removal or rendering inoperative by any person other than for purposes of maintenance, repair, or replacement of any device or element of design incorporated into any new vehicle for the purpose of noise control prior to its sale or delivery to the ultimate purchaser or while it is in use or (2) the use of the vehicle after such device or element of design has been removed or rendered inoperative by any person.

“AMONG THOSE ACTS PRESUMED TO CONSTITUTE TAMPERING ARE THE ACTS LISTED BELOW.”

These acts include tampering with the following systems; i.e., modification, removal, etc.

Exhaust system	Muffler Exhaust pipe Silencer
Intake system	Air cleaner case Air cleaner element Intake duct

CONSUMER INFORMATION

EAU01061

YAMAHA MOTOR CORPORATION, U.S.A. RIVA LIMITED WARRANTY

Yamaha Motor Corporation, U.S.A. hereby warrants that each new Yamaha Riva purchased from an authorized Yamaha Riva dealer in the continental United States will be free from defects in material and workmanship for the period of time stated herein, subject to certain stated limitations.

THE PERIOD OF WARRANTY for Yamaha Riva shall be one (1) year from the date of purchase, with no mileage limitation.

MODELS EXCLUDED FROM WARRANTY include those used for non-Yamaha-authorized renting, leasing, or other commercial purposes.

DURING THE PERIOD OF WARRANTY any authorized Yamaha motorcycle dealer will, free of charge, repair or replace any part adjudged defective by Yamaha due to faulty workmanship or material from the factory. Parts used in warranty repairs will be warranted for the balance of the product's warranty period. All parts replaced under warranty become property of Yamaha Motor Corp. U.S.A.

GENERAL EXCLUSIONS from this warranty shall include any failures caused by:

- Competition or racing use.
- Installation of parts or accessories that are not qualitatively equivalent to genuine Yamaha parts.
- Abnormal strain, neglect, or abuse.
- Lack of proper maintenance.
- Accident or collision damage.

SPECIFIC EXCLUSIONS from this warranty shall include parts replaced due to normal wear or routine maintenance.

THE CUSTOMER'S RESPONSIBILITY under this warranty shall be to:

- Operate and maintain the Riva as specified in the appropriate Owner's Manual, and

- Give notice to an authorized Yamaha Riva dealer of any and all apparent defects within ten (10) days after discovery, and make the machine available at that time for inspection and repairs at such dealer's place of business.

WARRANTY TRANSFER: To transfer the warranty from the original purchaser to any subsequent purchaser, it is imperative that the machine be inspected and registered for warranty by an authorized Yamaha Riva dealer. In order for this warranty to remain in effect, this inspection and registration must take place within ten (10) days after transfer. An inspection and registration fee will be charged for this service.

EMISSIONS CONTROL SYSTEM WARRANTY

Yamaha Motor Corporation, U.S.A. also warrants to the ultimate purchaser and each subsequent purchaser of each Yamaha Riva covered by this warranty with a displacement of 50cc or greater, that the vehicle is designed, built, and equipped so as to conform at the time of sale with all U.S. emissions standards applicable at the time of manufacture and that it is free from defects in materials and workmanship which would cause it not to meet these standards within the periods listed immediately below. Failure other than those resulting from defects in material or workmanship which arise solely as a result of owner abuse and / or lack of proper maintenance are not covered by this warranty.

ENGINE DISPLACEMENT	PERIOD
50cc to 169cc	12,000 km (7,465 miles) or five years, whichever occurs first
170cc to 279cc	18,000 km (11,185 miles) or five years, whichever occurs first
280cc or over	30,000 km (18,641 miles) or five years, whichever occurs first

YAMAHA MOTOR CORPORATION, U.S.A. MAKES NO OTHER WARRANTY OF ANY KIND, EXPRESSED OR IMPLIED. ALL IMPLIED WARRANTIES OF MERCHANTABILITY AND FITNESS FOR A PARTICULAR PURPOSE WHICH EXCEED THE OBLIGATIONS AND TIME LIMITS STATED IN THIS WARRANTY ARE HEREBY DISCLAIMED BY YAMAHA MOTOR CORPORATION, U.S.A. AND EXCLUDED FROM THIS WARRANTY.

SOME STATES DO NOT ALLOW LIMITATIONS ON HOW LONG AN IMPLIED WARRANTY LASTS, SO THE ABOVE LIMITATION MAY NOT APPLY TO YOU. ALSO EXCLUDED FROM THIS WARRANTY ARE ANY INCIDENTAL OR CONSEQUENTIAL DAMAGES INCLUDING LOSS OF USE. SOME STATES DO NOT ALLOW THE EXCLUSION OR LIMITATION OF INCIDENTAL OR CONSEQUENTIAL DAMAGES, SO THE ABOVE EXCLUSION MAY NOT APPLY TO YOU.

THIS WARRANTY GIVES YOU SPECIFIC LEGAL RIGHTS, AND YOU MAY ALSO HAVE OTHER RIGHTS WHICH VARY FROM STATE TO STATE.

YAMAHA MOTOR CORPORATION, U.S.A.
P. O. Box 6555
Cypress, California 90630

WARRANTY QUESTIONS AND ANSWERS

- Q. What costs are my responsibility during the warranty period?
- A. The customer's responsibility includes all costs of normal maintenance services, non-warranty repairs, accident and collision damages, and oil, oil filters, air filters, spark plugs, and brake shoes.
- Q. What are some examples of "abnormal" strain, neglect, or abuse?
- A. These terms are general and overlap each other in areas. Specific examples include: Running the machine out of oil, sustained high-rpm, full-throttle, operating the machine with a broken or damaged part which causes another part to fail, damage or failure due to improper or careless transportation and or tie down. If you have any specific questions on operation or maintenance, please contact your dealer for advice.
- Q. Does the warranty cover incidental costs such as towing or transportation due to a failure?
- A. No. The warranty is limited to repair of the machine itself.
- Q. May I perform any or all of the recommended maintenance shown in the Owner's Manual instead of having the dealer do them?
- A. Yes, if you are a qualified mechanic and follow the procedures specified in the Owner's and Service Manual. We do recommend, however, that items requiring special tools or equipment be done by Yamaha Riva dealer.
- Q. Will the warranty be void or cancelled if I do not operate or maintain my new Riva exactly as specified in the Owner's Manual?
- A. No. The warranty on a new Riva cannot be "voided" or "cancelled." **However, if a particular failure is caused by operation or maintenance other than as shown in the Owner's Manual, that failure may not be covered under warranty.**
- Q. What responsibility does my dealer have under this warranty?
- A. Each Yamaha Riva dealer is expected to:
1. Completely set up every new machine before sale.
 2. Explain the operation, maintenance, and warranty requirements to your satisfaction at the time of sale, and upon your request at any later date.
 3. Each Yamaha Riva dealer is held responsible for his setup, service and warranty repair work.
- Q. Is the warranty transferable to second owners?
- A. Yes. The remainder of the existing warranty can be transferred upon request. The unit has to be inspected and re-registered by an authorized Yamaha Riva dealer for the policy to remain effective.

CUSTOMER SERVICE

If your machine requires warranty service, you must take it to any authorized Yamaha Riva dealer within the continental United States. Be sure to bring your warranty registration card or other valid proof of the original date of purchase. If a question or problem arises regarding warranty, first contact the owner of the dealership. Since all warranty matters are handled at the dealer level, this person is in the best position to help you. If you are still not satisfied and require additional assistance, please write:

YAMAHA MOTOR CORPORATION U.S.A.
CUSTOMER RELATIONS DEPARTMENT
P.O. Box 6555
Cypress, California 90630

When contacting Yamaha Motor Corporation, U.S.A. don't forget to include any important information such as names, addresses, model, V.I.N. (frame number), dates, and receipts.

CHANGE OF ADDRESS

The federal government requires each manufacturer of a motor vehicle to maintain a complete, up-to-date list of all first purchasers against the possibility of a safety-related defect and recall. This list is compiled from the purchase registrations sent to Yamaha Motor Corporation, U.S.A. by the selling dealer at the time of your purchases.

If you should move after you have purchased your new motorcycle, please advise us of your new address by sending a postcard listing your Riva model name, V.I.N. (frame number), dealer number (or dealer's name) as it is shown on your warranty card, your name and new mailing address. Mail to:

YAMAHA MOTOR CORPORATION, U.S.A.
P.O. Box 6555
Cypress, California 90630
Attention: Warranty Department

This will ensure that Yamaha Motor Corporation, U.S.A. has an up-to-date registration record in accordance with federal law.

CONSUMER INFORMATION

EAU01063

YAMAHA EXTENDED SERVICE (Y.E.S.)

Keep your Yamaha protected even after your warranty expires with genuine Yamaha Extended Service (Y.E.S.).

- Y.E.S. is designed and administered by Yamaha Motor Corporation to provide maximum owner satisfaction. You get uninterrupted factory-backed coverage for extra peace of mind.
- Y.E.S. is flexible. You choose the plan that's right for you: 12 months, 24 months, or 36 months beyond your warranty period.
- Y.E.S. is designed and administered by the same Yamaha people who handle your warranty — and it shows in the comprehensive coverage benefits. There are no mileage limitations. Coverage isn't limited to "moving parts" or the "drive train" like many other plans. And Y.E.S. covers manufacturing defects just like the warranty. See the sample contract at your Yamaha dealer to see how comforting uninterrupted factory-backed protection can be.
- You don't have to pay anything for covered repairs. There's no deductible to pay, and repairs aren't "pro-rated." You don't have any "out-of-pocket" expenses for covered repairs.
- In addition, Travel and Recreation Interruption Protection (TRIP) is included at no extra cost. TRIP gives you up to \$150 reimbursement per occurrence for any reasonable expenses you incur because your Yamaha needs covered service: replacement vehicle rental, emergency towing, phone calls, even food and lodging when you are away from home. This superb coverage goes into effect when you purchase Y.E.S., so it applies to any warranty repairs as well as covered repairs during your entire Y.E.S. plan period.
- Y.E.S. coverage is honored at any authorized Yamaha dealer nationwide.
- Y.E.S. coverage is transferable to a new owner if you sell or trade-in. That can make your Yamaha much more valuable!

This excellent Y.E.S. plan coverage is only available to Yamaha owners like you, and only while your Yamaha is still within the Yamaha Limited Warranty period. So visit your authorized Yamaha dealer to get all the facts. He can show you how easy it is to protect your investment with Yamaha Extended Service.

CONSUMER INFORMATION

We urge you to act now. You'll get the excellent benefits of TRIP coverage right away, and you'll rest easy knowing you'll have strong factory-backed protection even after your Yamaha Limited Warranty expires. You can also save money: Y.E.S. costs less within the first 90 days after you buy your Yamaha. See your dealer today!

A special note:

If visiting your dealer isn't convenient, contact Yamaha with your Primary ID number (your frame number). We'll be happy to help you get the Y.E.S. coverage you need.

Yamaha Service Marketing
P.O. Box 6555
Cypress, CA 90630



YAMAHA EXTENDED SERVICE