

YAMAHA

82 riva

OWNER'S MANUAL

JOG

CY50K

LIT-11626-10-83

4FB-28199-17

Dear Yamaha ATV Owner: Please Review this IMPORTANT SAFETY CARD before operating your ATV (if card is not attached, call 1-800-344-6418).

Dear New Yamaha ATV Owner:

CONGRATULATIONS ON THE PURCHASE OF YOUR NEW YAMAHA ATV. You have purchased a quality Yamaha product that, with proper use and care, will provide hours of riding pleasure. **BEFORE YOU OPERATE YOUR NEW ATV, Yamaha recommends these important points:**

- READ YOUR OWNER'S MANUAL
- A CHILD UNDER 12 YEARS OLD SHOULD NOT OPERATE AN ATV WITH ENGINE SIZE 70CC OR GREATER
- A CHILD UNDER 16 YEARS OLD SHOULD NOT OPERATE AN ATV WITH ENGINE SIZE GREATER THAN 90CC
- TAKE THE FREE HANDS-ON TRAINING COURSE OFFERED BY YAMAHA — ASK YOUR DEALER FOR DETAILS OR CALL 1-800-887-2887

If you have any questions about these points, **or if you purchased your ATV from an authorized Yamaha dealership and were not informed of the age recommendation for your ATV by the dealership**, please fill out the information below and mail this card to Yamaha **today**.

Name:

Address: _____

Telephone:

() _____

ATV Model:

Primary I.D. (Engine Number): _____

Purchase Date:

MO. DAY YR.

Dealer Name & Address:

CAREFULLY
READ

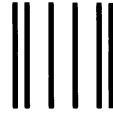

NO POSTAGE
NECESSARY
IF MAILED
IN THE
UNITED STATES

BUSINESS REPLY MAIL
FIRST CLASS PERMIT NO. 4 CYPRESS, CA

POSTAGE WILL BE PAID BY ADDRESSEE

YAMAHA MOTOR CORPORATION U.S.A.
P.O. BOX 6555
CYPRESS, CALIFORNIA 90630-9989

ATTN: SALES ADMINISTRATION

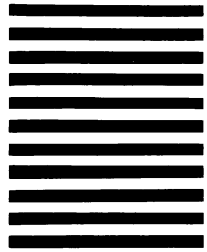

INTRODUCTION

Congratulations on your purchase of the Yamaha CY50. This model is the result of Yamaha's vast experience in the production of fine sporting, touring, and pacesetting racing machines. It represents the high degree of craftsmanship and reliability that have made Yamaha a leader in these fields.

This manual will give you an understanding of the operation, inspection, and basic maintenance of this scooter. If you have any questions about the operation or maintenance of your scooter, please consult a Yamaha dealer.

IMPORTANT MANUAL INFORMATION

Particularly important information is distinguished in this manual by the following notations:



The Safety Alert Symbol means **ATTENTION! BECOME ALERT! YOUR SAFETY IS INVOLVED!**



Failure to follow **WARNING** instructions could result in severe injury or death to the scooter operator, a bystander or a person inspecting or repairing the scooter.

CAUTION:

A **CAUTION** indicates special precautions that must be taken to avoid damage to the scooter.

NOTE:

A **NOTE** provides key information to make procedures easier or clearer.

NOTE:

- This manual should be considered a permanent part of this scooter and should remain with it even if the scooter is subsequently sold.
 - Yamaha continually seeks advancements in product design and quality. Therefore, while this manual contains the most current product information available at the time of printing, there may be minor discrepancies between your scooter and this manual. If there is any question concerning this manual, please consult your Yamaha dealer.
-

 **WARNING**

PLEASE READ THIS MANUAL AND THE “YOU AND YOUR MOTORCYCLE: RIDING TIPS” BOOKLET CAREFULLY AND COMPLETELY BEFORE OPERATING THIS SCOOTER. DO NOT ATTEMPT TO OPERATE THIS SCOOTER UNTIL YOU HAVE ATTAINED A SATISFACTORY KNOWLEDGE OF ITS CONTROLS AND OPERATING FEATURES AND UNTIL YOU HAVE BEEN TRAINED IN SAFE AND PROPER RIDING TECHNIQUES. REGULAR INSPECTIONS AND CAREFUL MAINTENANCE, ALONG WITH GOOD RIDING SKILLS, WILL ENSURE THAT YOU SAFELY ENJOY THE CAPABILITIES AND THE RELIABILITY OF THIS SCOOTER.

AFFIX DEALER

LABEL HERE

EAA00000

CY50K
OWNER'S MANUAL
©1997 by Yamaha Motor Corporation, U.S.A.
1st Edition, April 1997
All rights reserved. Any reprinting or
unauthorized use without the written
permission of Yamaha Motor Corporation,
U.S.A. is expressly prohibited.
Printed in Japan
P/N LIT-11626-10-83

CONTENTS

SAFETY INFORMATION	1-1	Oil level indicator light circuit check ..	6-4
FURTHER SAFE RIDING POINTS FOR THIS MODEL	2-1	Speedometer	6-5
LOCATION OF THE IMPORTANT LABELS.....	3-1	Fuel gauge	6-5
DESCRIPTION	4-1	Handlebar switches.....	6-6
SCOOTER IDENTIFICATION	5-1	Front brake lever	6-7
Identification numbers record.....	5-1	Rear brake lever.....	6-8
Key identification number	5-1	Fuel tank cap.....	6-8
Vehicle identification number	5-2	Oil tank cap	6-9
Model label.....	5-2	Kick starter	6-10
CONTROL FUNCTIONS	6-1	Seat.....	6-11
Main switch	6-1	Helmet holder	6-11
Steering lock	6-2	Trunk.....	6-12
Indicator lights	6-3	Storage compartment.....	6-13
		Rear carrier.....	6-13
		PRE-OPERATION CHECKS	7-1
		Brakes	7-3
		Throttle grip	7-4
		Engine oil	7-4
		Air filter.....	7-5

Tires.....	7-5
Accessories or replacement parts.....	7-8
Lights, signals and switches.....	7-9
Fuel.....	7-9

OPERATION AND IMPORTANT

RIDING POINTS	8-1
Starting and warming up a cold engine	8-1
Starting the scooter	8-3
Acceleration.....	8-3
Braking.....	8-3
Engine break-in	8-5
Parking	8-6

PERIODIC MAINTENANCE

AND MINOR REPAIR.....	9-1
Periodic maintenance / lubrication	9-2
Air filter element cleaning	9-4
Spark plug inspection.....	9-7

Front and rear brake lever free play adjustment.....	9-8
Checking the brake shoes.....	9-9
Battery	9-10
Fuse replacement.....	9-11
Troubleshooting	9-13
Troubleshooting chart.....	9-14

CLEANING AND STORAGE	10-1
A. Cleaning.....	10-1
B. Storage.....	10-2

SPECIFICATIONS	11-1
----------------------	------

CONSUMER INFORMATION	12-1
Reporting safety defects.....	12-1
Scooter noise regulation	12-2
Riva limited warranty.....	12-3
Yamaha extended service	12-5

⚠ SAFETY INFORMATION

TWO-WHEELED SCOOTERS ARE SINGLE TRACK VEHICLES. THEIR SAFE USE AND OPERATION ARE DEPENDENT UPON THE USE OF PROPER RIDING TECHNIQUES AS WELL AS THE EXPERTISE OF THE OPERATOR.

EVERY OPERATOR SHOULD KNOW THE FOLLOWING REQUIREMENTS BEFORE RIDING.

HE OR SHE SHOULD:

- 1. OBTAIN THOROUGH INSTRUCTIONS FROM A COMPETENT SOURCE ON ALL ASPECTS OF SCOOTER OPERATION.**
- 2. OBSERVE THE WARNINGS AND MAINTENANCE REQUIREMENTS IN THE OWNER'S MANUAL.**
- 3. OBTAIN QUALIFIED TRAINING IN SAFE AND PROPER RIDING TECHNIQUES.**
- 4. OBTAIN PROFESSIONAL TECHNICAL SERVICE AS INDICATED BY THE OWNER'S MANUAL AND/OR WHEN MADE NECESSARY BY MECHANICAL CONDITIONS.**

SAFE RIDING

- 1. Always make pre-operation checks. Careful checks may help prevent an accident.**
- 2. This scooter is designed to carry the operator only. No passengers.**

- 3. The failure of motorists to detect and recognize scooters in traffic is the predominant cause of automobile/scooter accidents. Many accidents have been caused by an automobile driver who did not see the scooter. Making yourself conspicuous appears to be very effective in reducing the chance of this type of accident.**

Therefore:

- a. Wear a brightly colored jacket.**
 - b. Use extra caution when you approach and pass through intersections, since intersections are the most likely places for scooter accidents.**
 - c. Ride where other motorists can see you. Avoid riding in another motorist's "blind spot".**
- 4. Many accidents involve inexperienced operators. In fact, many operators who have been involved in accidents do not even have a current driver's license.**
 - a. Make sure you are qualified. Also, only lend your scooter to experienced operators.**
 - b. Know your skills and limits. Staying within your limits may help you to avoid an accident.**
 - c. We recommend that you practice riding your scooter where there is no traffic until you have become thoroughly familiar with your scooter and all of its controls.**
 - 5. Many scooter accidents have been caused by scooter operator errors. A typical error made by the operator is veering wide on a turn due to EXCESSIVE SPEED or undercornering (insufficient lean angle for the speed).**

- a. **Always obey the speed limits and never travel faster than warranted by road and traffic conditions.**
 - b. **Always signal before turning or changing lanes. Make sure other motorists see you.**
6. **The operator's posture is important for proper control. The operator should keep both hands on the handlebars and both feet on the footboard during operation to maintain control of the scooter.**
 7. **Never ride under the influence of alcohol or drugs.**
 8. **This scooter is designed for on-road use only. It is not suitable for off-road use.**

PROTECTIVE APPAREL

The majority of fatalities from scooter accidents are the result of head injuries. The use of a safety helmet is the single most critical factor in the prevention or reduction of head injuries.

1. **Always wear an approved helmet.**
2. **Wear a face shield or goggles. Wind on your unprotected eyes could contribute to an impairment of vision which could delay seeing a hazard.**
3. **The use of substantial shoes, jacket, trousers, gloves, etc. is effective in preventing or reducing abrasions or lacerations.**

- 4. Never wear loose fitting clothing. It could catch on the control levers or wheels and cause injury or accident.**
- 5. Never touch the engine or exhaust system during or after operation. They become very hot and can cause burns. Always wear protective clothing that covers your legs, ankles, and feet.**

MODIFICATION

Modifications made to the scooter not approved by Yamaha, or the removal of original equipment, may render your scooter unsafe for use and may cause severe personal injury. Modifications may also make your scooter illegal to use.

LOADING AND ACCESSORIES

Adding accessories or cargo to your scooter can adversely affect stability and handling if the weight distribution of the machine is changed. To avoid the possibility of an accident, extreme caution should be used if adding cargo or accessories to your scooter. Use extra care if riding a scooter which has added cargo or accessories. Here are some general guidelines to follow if loading cargo or adding accessories to your scooter:

LOADING

The total weight of the operator, accessories and cargo must not exceed the maximum load limit of 165 lbs. (75 kg).

When loading within these weight limits, keep the following in mind:

1. Cargo and accessory weight should be kept as low and close to the scooter as possible. Be sure to distribute the weight as evenly as possible on both sides of the machine to minimize imbalance or instability.
2. Shifting weights can create a sudden imbalance. Make sure that accessories and cargo are securely attached to the scooter before riding. Recheck accessory mounts and cargo restraints frequently.
3. Never attach any large or heavy items to the handlebars, front forks, or front fender. These items can create unstable handling or slow steering response.

ACCESSORIES

Genuine Yamaha accessories have been specifically designed for use on this scooter. Since Yamaha cannot test all other accessories which may be available, you must personally be responsible for the proper selection, installation and use of non-Yamaha accessories. You should use extreme caution when selecting and installing any accessories.

Keep in mind these guidelines for mounting accessories in addition to those provided under “LOADING”.

- 1. Never install accessories or carry cargo that would impair the performance of your scooter. Carefully inspect the accessory before using it to make sure it does not in any way reduce ground clearance or cornering clearance, limit suspension travel, steering travel or control operation, or obscure lights or reflectors.**
 - a. Accessories fitted to the handlebar or the front fork area can create instability due to improper weight distribution or aerodynamic changes. If accessories are added to the handlebar or front fork area, they must be as lightweight as possible and should be kept to a minimum.**
 - b. Bulky or large accessories may seriously affect the stability of the scooter due to aerodynamic effects. Wind may attempt to lift the scooter, or the scooter may become unstable in cross winds. These accessories may also cause instability when being passed by or passing large vehicles.**
 - c. Certain accessories can displace the operator from his or her normal riding position. This improper position limits the freedom of movement of the operator and may limit control ability. Therefore such accessories are not recommended.**
- 2. Caution must be used if adding electrical accessories. If these accessories exceed the capacity of the scooter’s electrical system, an electric failure could result, which could cause a dangerous loss of lights or engine power.**

GASOLINE AND EXHAUST GAS

- 1. GASOLINE IS HIGHLY FLAMMABLE:**
 - a. Always turn off the engine when refueling.**
 - b. Take care not to spill any gasoline on the engine or exhaust system when refueling.**
 - c. Never refuel while smoking or in the vicinity of an open flame.**
- 2. Never start the engine or let it run for any length of time in a closed area. The exhaust fumes are poisonous and may cause loss of consciousness and death within a short time. Always operate your scooter in an area that has adequate ventilation.**
- 3. Always turn off the engine before leaving the scooter unattended and remove the ignition key. When parking the scooter, note the following:**
 - a. The engine and exhaust system may be hot. Park the scooter in a place where pedestrians or children are not likely to touch these hot areas.**
 - b. Do not park the scooter on a slope or soft ground; the scooter may fall over.**
 - c. Do not park the scooter near a flammable source, e.g. a kerosene heater, or near an open flame. The scooter could catch fire.**
- 4. If you should swallow any gasoline, inhale a lot of gasoline vapor, or allow gasoline to get in your eyes, see your doctor immediately. If any gasoline spills on your skin or clothing, immediately wash with soap and water and change your clothes.**

FURTHER SAFE RIDING POINTS FOR THIS MODEL

1. Be sure to signal clearly in the following instances:

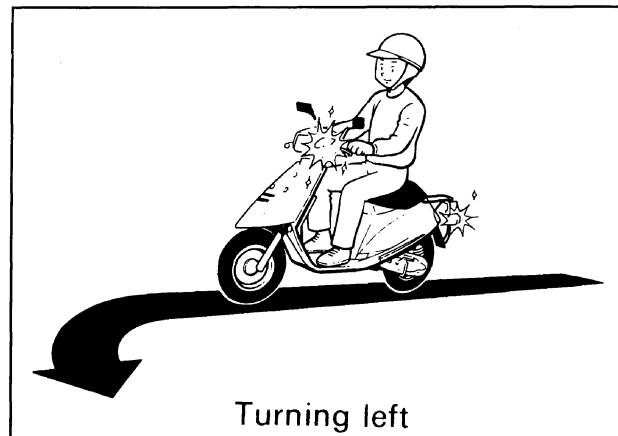
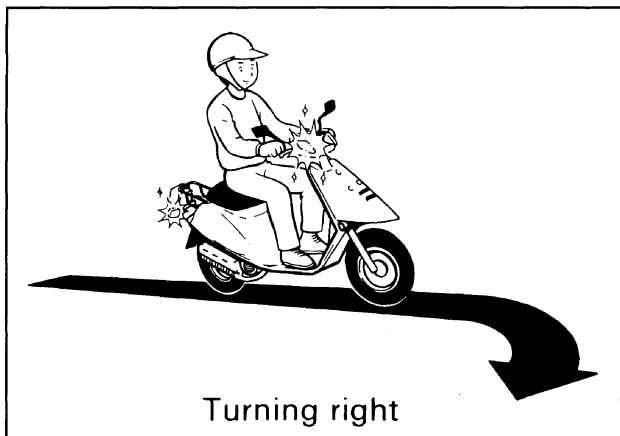

2. Braking can be extremely difficult on a wet road. Avoid hard braking, because the scooter could slide. Apply the brakes slowly when stopping on a wet surface.
3. Slow down as you approach a corner or turn. Once you have completed a turn, accelerate slowly.
4. Be careful when passing parked cars. A driver might not see you and open a door in your path.

- 5. Street car rails, iron plates on road construction sites, and man-hole covers become extremely slippery when wet. Slow down and cross them with caution. Keep the scooter upright. It could slide out from under you.**
- 6. The brake lining could get wet when you wash the scooter. After washing the scooter, check the brakes before riding.**
- 7. Always wear a helmet, gloves, trousers (tapered around the cuff and ankle so they do not flap), and a bright colored jacket.**
- 8. Do not carry too much luggage on the scooter. An overloaded scooter is unstable. Refer to "SAFETY INFORMATION" for instructions about carrying luggage. Use a strong cord to secure any luggage to the luggage racks. A loose load will affect the stability of the scooter and could divert your attention from the road.**

LOCATION OF THE IMPORTANT LABELS

Please read the following labels carefully before operating this scooter.

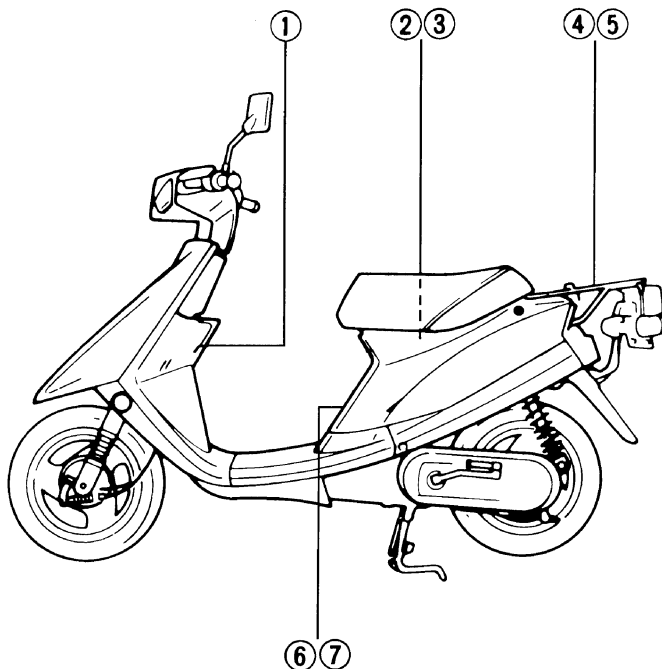

①

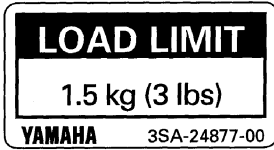

②

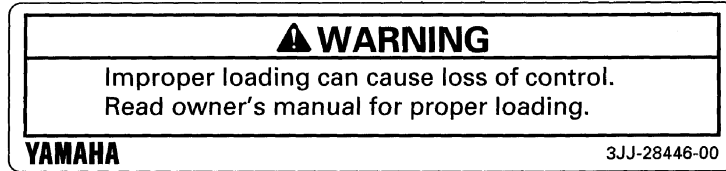

③

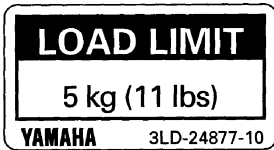

④

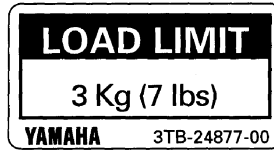

⑤



⑥

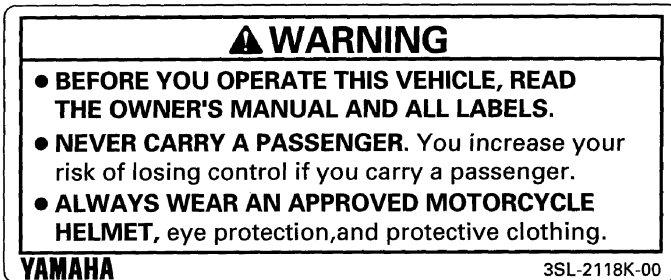

⑦

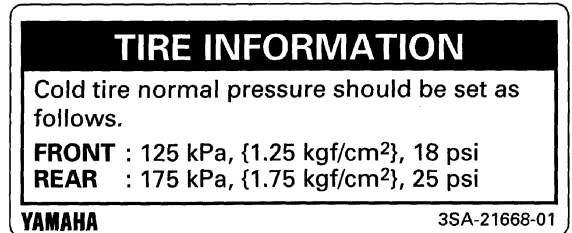

DESCRIPTION

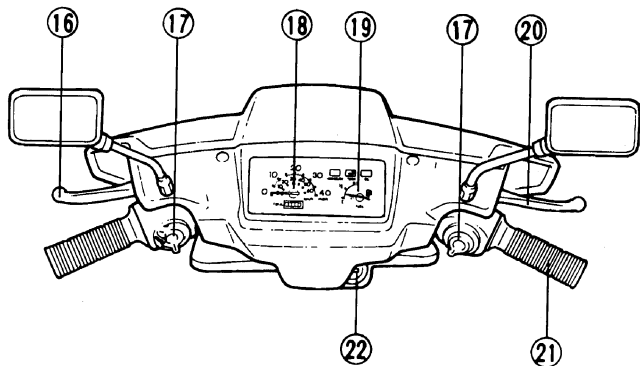
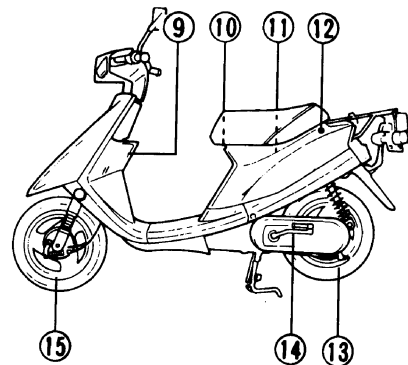
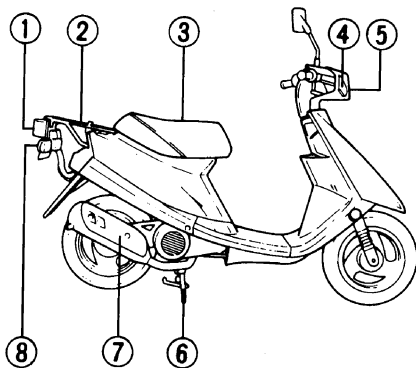

- | | |
|------------------------------|------------------------|
| 1. Tail/brake light | 12. Seat lock |
| 2. Rear carrier | 13. Rear wheel |
| 3. Seat | 14. Kick starter |
| 4. Front flasher light | 15. Front wheel |
| 5. Headlight | 16. Rear brake lever |
| 6. Centerstand | 17. Handlebar switches |
| 7. Muffler | 18. Speedometer |
| 8. Rear flasher light | 19. Fuel gauge |
| 9. Front storage compartment | 20. Front brake lever |
| 10. Helmet holder | 21. Throttle grip |
| 11. Trunk | 22. Main switch |

SCOOTER IDENTIFICATION

Identification numbers record

Record the key identification number, vehicle identification number and model label information in the spaces provided for assistance when ordering spare parts from a Yamaha dealer or for reference in case the vehicle is stolen.

1. KEY IDENTIFICATION NUMBER:

2. VEHICLE IDENTIFICATION NUMBER:

3. MODEL LABEL INFORMATION:

Key identification number

The key identification number is stamped on the key. Record this number in the space provided and use it for reference when obtaining a new key.

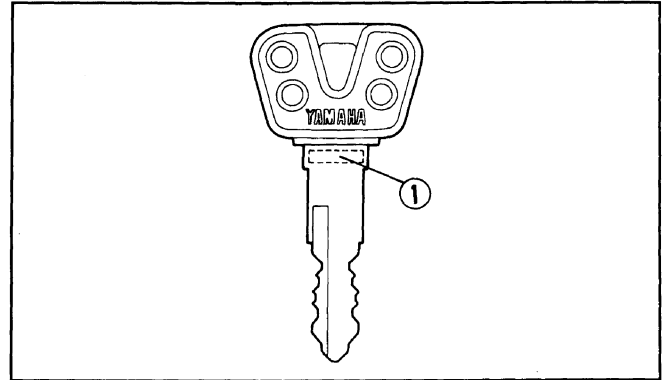

1. Key identification number

Vehicle identification number

The vehicle identification number is stamped into the frame.

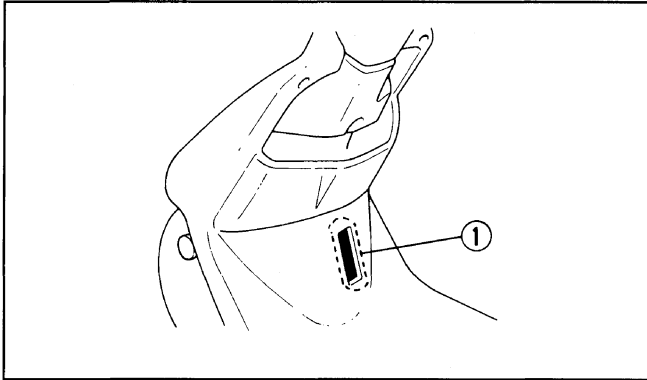

1. Vehicle identification number

EUU00400

NOTE:

The vehicle identification number is used to identify your scooter and may be used to register your scooter with the licensing authority in your state.

Model label

The model label is affixed to the location shown in the figure. Record the information on this label in the space provided. This information will be needed to order spare parts from your Yamaha dealer.

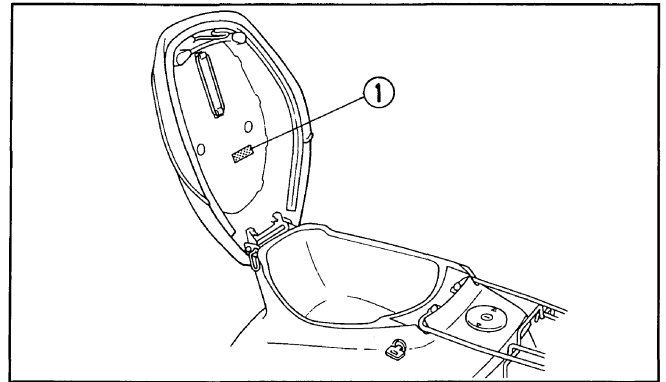

1. Model label

CONTROL FUNCTIONS

EAB00100

Main switch

The main switch controls the ignition and lighting systems. Its operation is described below.

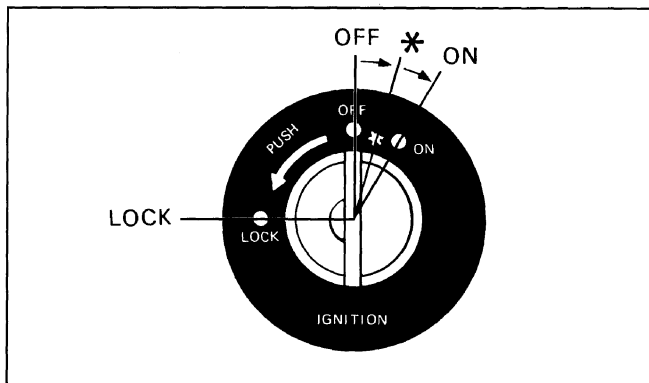

EAB02300

ON:

Electrical circuits are switched on and the taillight comes on. The engine can be started. The key cannot be removed in this position.

EUA10100

NOTE:

When the engine is started, the headlight and meter lights come on automatically.

EAB00600

OFF:

All electrical circuits are switched off. The key can be removed in this position.

EAB02101

* :

The oil level indicator light will come on. For details of the oil level indicator light, refer to "Oil level indicator light" on page 6-3.

EAB00701

LOCK:

The steering is locked in this position, and all electrical circuits are switched off. The key can be removed in this position. Refer to "Steering lock" (page 6-2) for operation instructions.

NOTE:

Always turn the main switch to "OFF" or "LOCK" and remove the key when the scooter is unattended.

Steering lock

The steering is locked when the main switch is turned to "LOCK". To lock the steering, turn the handlebars all the way to the left. With the key at "OFF", push it into the main switch and release it, turn it counterclockwise to "LOCK", and remove it. To release the lock, turn the key to "OFF".

! WARNING

Never turn the key to "LOCK" when the scooter is moving.

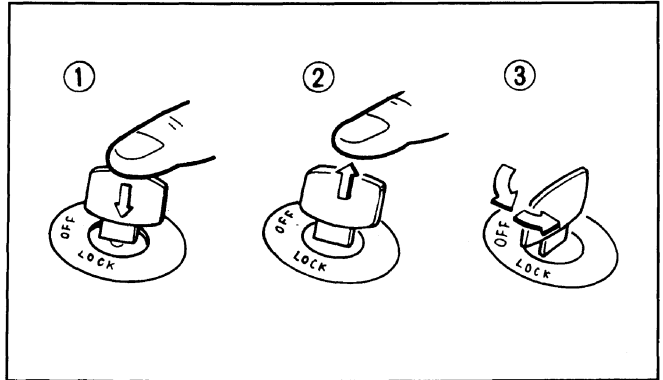
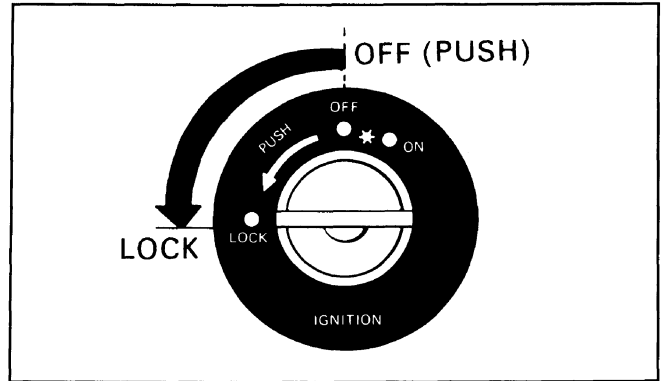

1. Push

2. Release

3. Turn

Indicator lights

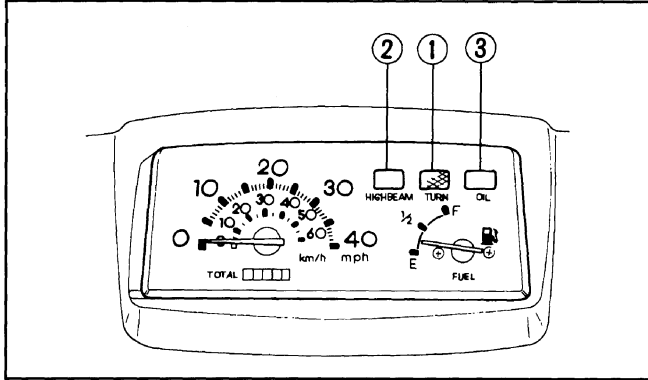

1. Turn indicator light "TURN"
2. High beam indicator light "HIGH BEAM"
3. Oil level indicator light "OIL"

Turn indicator light "TURN"

This indicator flashes when the turn switch is moved to the left or right.

High beam indicator light "HIGH BEAM"

This indicator comes on when the headlight high beam is used.

Oil level indicator light "OIL"

The light comes on when the main switch is at " * " or when there is little oil in the oil tank during operation. If the oil level indicator light comes on during operation, refill the tank immediately with Yamalube 2-cycle engine oil or air cooled 2-stroke engine oil. When the tank is refilled, the indicator light will go off.

NOTE:

If the oil level indicator light does not come on while the key is at " * ", have a Yamaha dealer inspect it.

CAUTION:

Do not run the scooter until you know it has sufficient engine oil.

Oil level indicator light circuit check

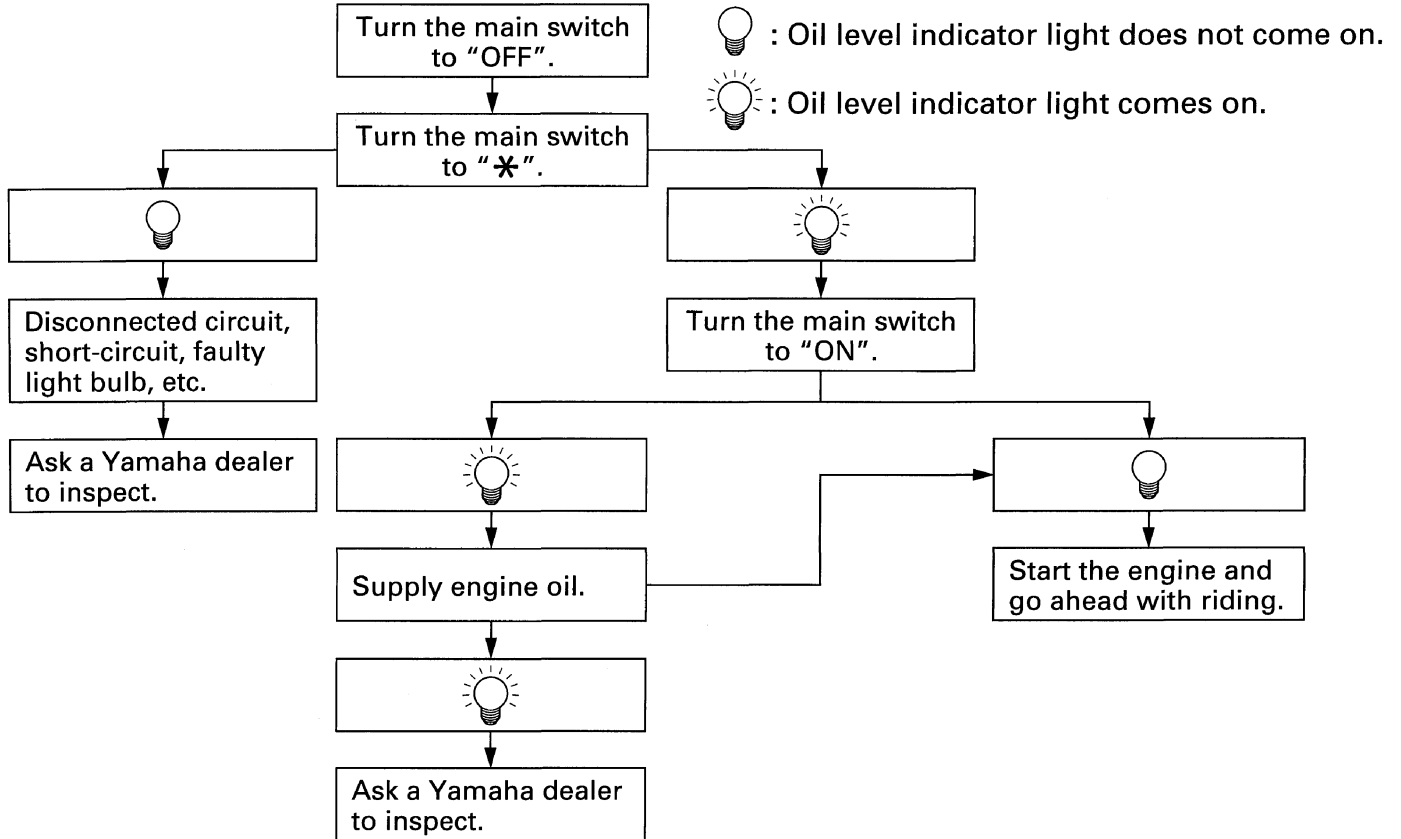

Speedometer

The speedometer shows riding speed. This speedometer is equipped with an odometer.

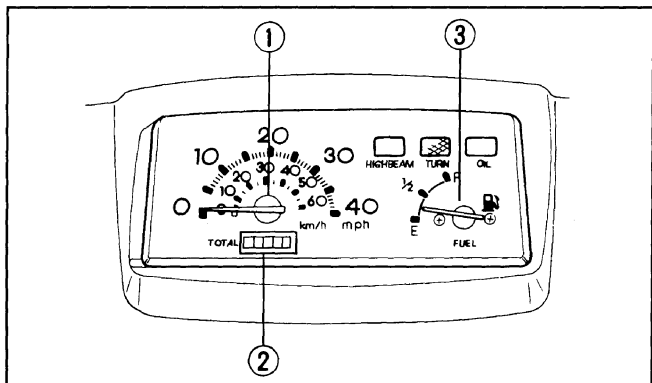

1. Speedometer 2. Odometer 3. Fuel gauge

Fuel gauge

The fuel gauge indicates the quantity of the remaining gasoline in the tank. The gauge needle moves from "F" (Full) to "E" (Empty) as the fuel level decreases. When the needle moves to the "E" position, add fuel as soon as possible.

EUU09701

NOTE: _____
 The needle of this fuel gauge does not move when the main switch is turned to "OFF".

Handlebar switches

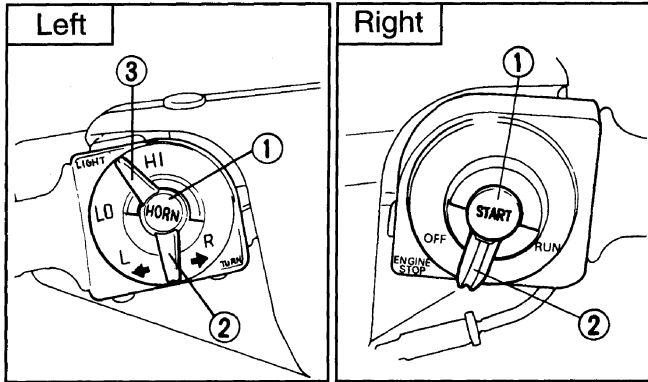

- | | |
|------------------------------|-------------------------------------|
| 1. Horn switch "HORN" | 1. Start switch "START" |
| 2. Turn signal switch "TURN" | 2. Engine stop switch "ENGINE STOP" |
| 3. Dimmer switch "LIGHTS" | |

Dimmer switch "LIGHTS"

Turn the switch to "HI" for the high beam and to "LO" for the low beam.

Turn signal switch "TURN"

This is a three-position switch. The center position is off. Turn to "L" to turn on the left flasher, and to "R" for the right flasher. Be sure to turn the switch off after completing a turn.

Horn switch "HORN"

Press the switch to sound the horn.

Engine stop switch "ENGINE STOP"

The engine stop switch is a safety device for use in an emergency such as when the scooter overturns or if trouble occurs in the throttle system. Turn the switch to "RUN" to start the engine. In case of emergency, turn the switch to "OFF" to stop the engine.

EAB61902

Start switch "START"

The starter motor cranks the engine when pushing the start switch while applying the front or rear brake.

EUU30700

CAUTION

See starting instructions prior to starting the engine.

EAB90001

Front brake lever

The front brake lever is located on the right handlebar. Pull it toward the handlebar to apply the front brake.

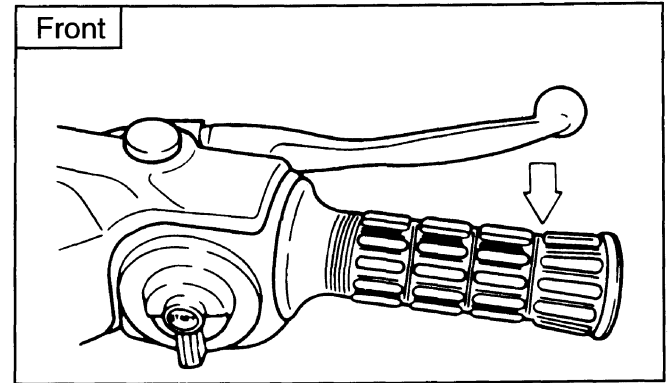

Rear brake lever

The rear brake lever is located on the left handlebar. Pull it toward the handlebar to apply the rear brake.

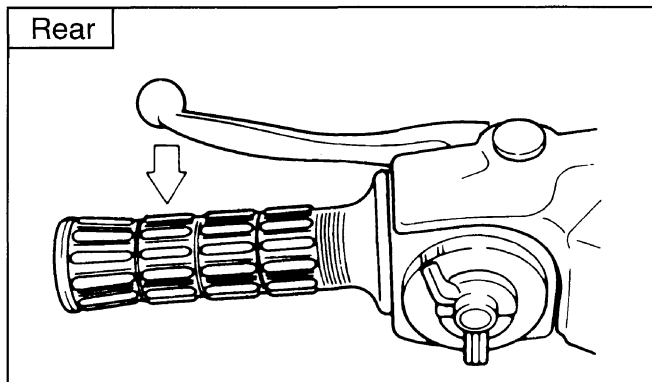

Fuel tank cap

TO OPEN:

Slide the cover open. Insert the key and turn it 1/4 turn clockwise. The lock will be released and the cap can be opened.

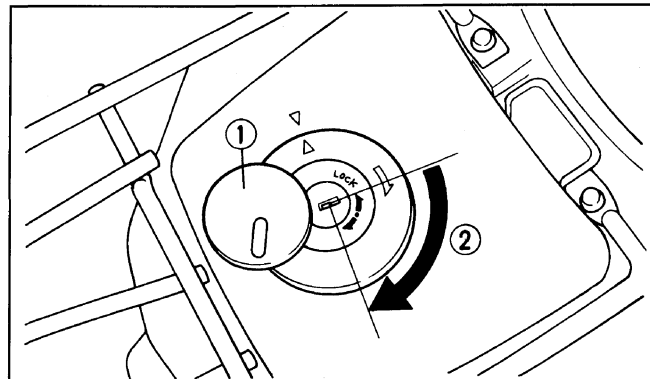

1. Cover

2. Open

TO CLOSE:

Align the match marks and push the tank cap into position with the key inserted. To remove the key, turn it counterclockwise to the original position. Close the cover.

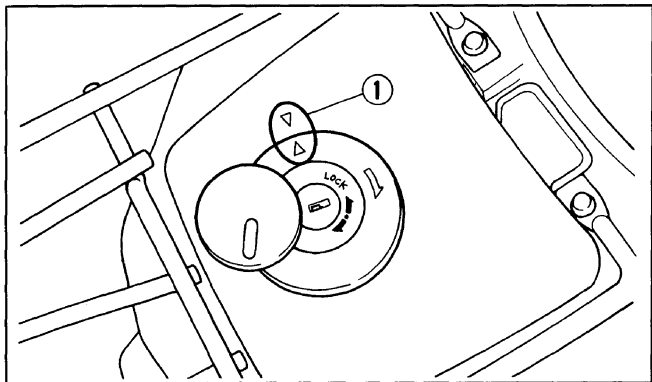

1. Match marks

EUU01200

NOTE:

This tank cap cannot be closed unless the key is in the lock. The key cannot be removed if the cap is not locked properly.

EUU61100

! WARNING

Be sure the cap is properly installed and locked in place before riding the scooter.

EAC01001

Oil tank cap

Remove the front cover.

Pull the oil tank cap up to remove it.

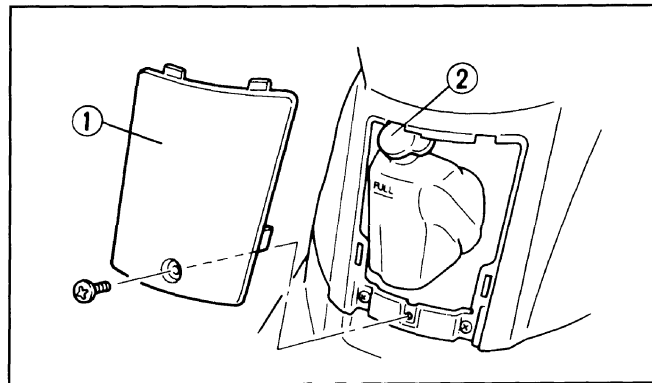

1. Front cover

2. Oil tank cap

NOTE: _____
Be sure the cap is properly seated when replacing.

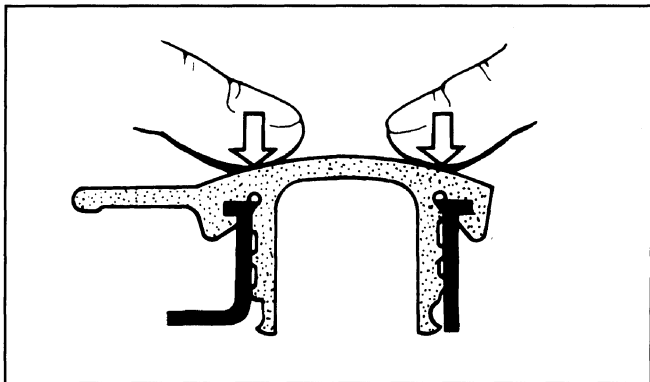

Kick starter

Rotate the kick starter away from the engine. Push the starter down lightly with your foot until the gears engage, then kick smoothly and forcefully to start the engine.

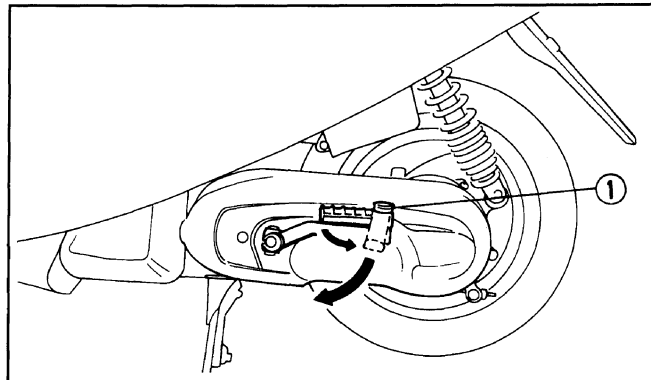

1. Kick starter

Seat

To open the seat:

1. Insert the key in the lock and turn it as shown.
2. Lift the end of the seat up to open.

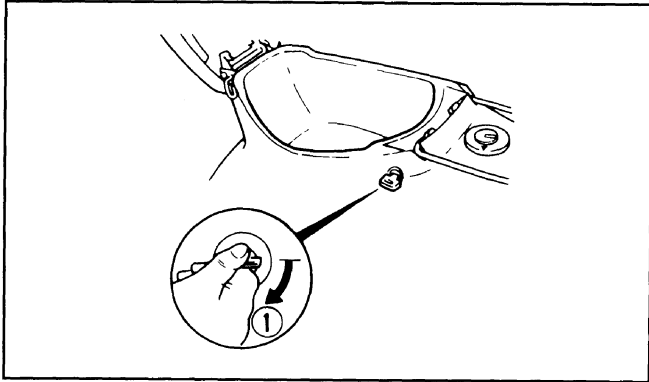

1. Open

To lock the seat:

1. Replace the seat in the original position.
2. Slightly push the end of the seat down to lock.

NOTE: _____

Lift the end of the seat up to make sure the seat is securely locked.

Make sure the key is not in the trunk when locking the seat.

Helmet holder

The helmet holder is located under the seat. Open the seat and hook the helmet on the helmet holder. Then lock the seat.

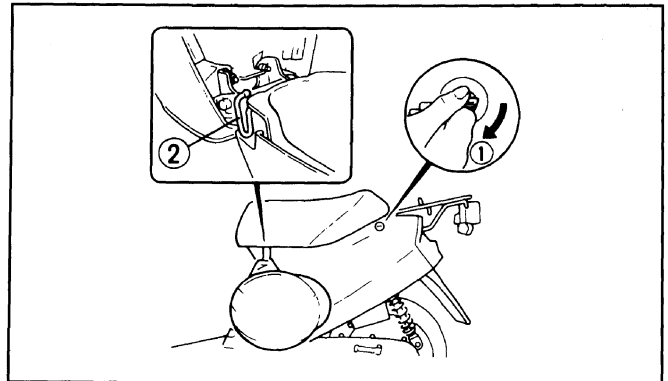

1. Open

2. Helmet holder

⚠ WARNING

Never ride with a helmet in the helmet holder. The helmet may hit objects, causing loss of control and possibly an accident.

Trunk

The trunk is under the seat.

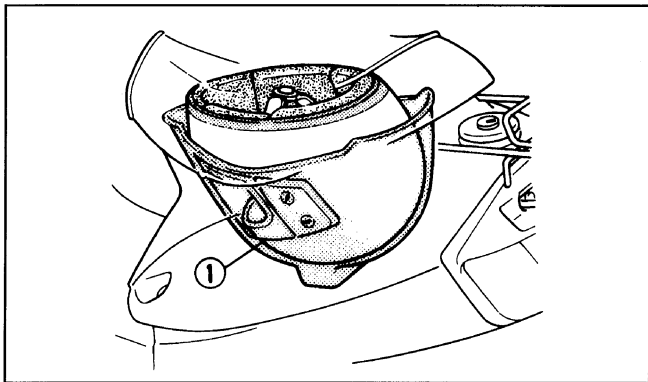

1. Trunk

⚠ WARNING

Do not exceed the load limit of 5 kg (11 lbs).

CAUTION:

Keep the following in mind when using the trunk.

1. The trunk gets hot inside when exposed to the sun. Do not put anything in the trunk susceptible to heat.
2. Put wet articles in a vinyl bag when storing them in the trunk.
3. The trunk may get wet while the scooter is being washed. Put articles in a vinyl bag before storing them in the trunk.
4. Do not put anything in the trunk that is valuable or easy to break.

When storing a helmet in the trunk, place it upside-down with the front facing forward.

EUU13901

NOTE: _____

- Some helmets cannot be stored in the trunk because of their size or shape.
- Do not leave your scooter with the seat open.

EAC74501

Storage compartment

EUU76001

⚠ WARNING _____

Do not exceed the load limit of 1.5 kg (3 lbs).

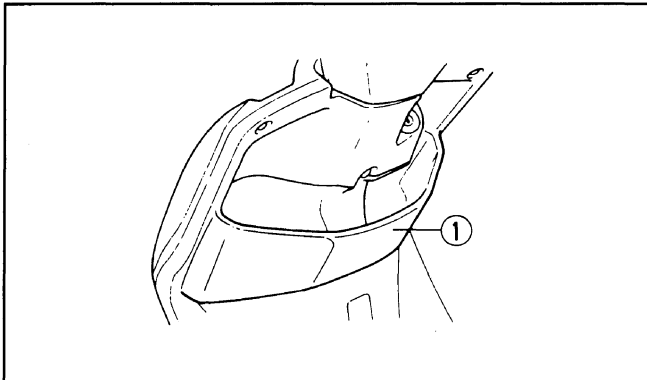

1. Front storage compartment

EAC72001

Rear carrier

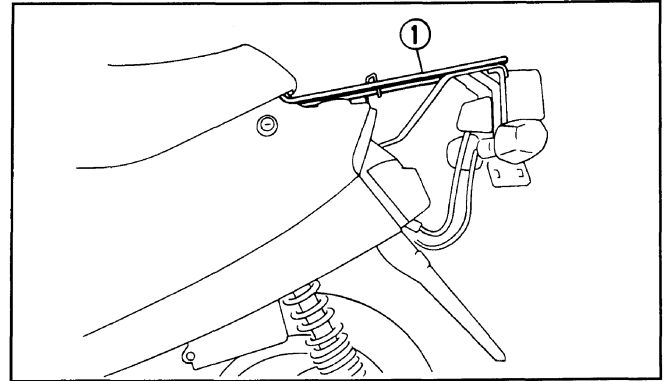

1. Rear carrier

EUU76001

⚠ WARNING _____

Do not exceed the load limit of 3 kg (7 lbs).

PRE-OPERATION CHECKS

Owners are personally responsible for their vehicle's condition. Your scooter's vital functions can start to deteriorate quickly and unexpectedly, even if it remains unused (for instance, if it is exposed to the elements). Any damage, fluid leak or loss of tire pressure could have serious consequences. Therefore, it is very important that, in addition to a thorough visual inspection, you check the following points before each ride.

ITEM	ROUTINE	PAGE
Front and rear brakes	<ul style="list-style-type: none"> • Check operation, condition and free play. • Adjust if necessary. 	7-3, 9-8 ~ 9-9
Throttle grip and housing	<ul style="list-style-type: none"> • Check for smooth operation. • Lubricate/adjust if necessary. 	7-4
Engine oil	<ul style="list-style-type: none"> • Check oil level/Fill with oil if necessary. 	7-4 ~ 7-5
Wheels and tires	<ul style="list-style-type: none"> • Check tire pressure, wear and damage. 	7-5 ~ 7-8
Control and meter cable	<ul style="list-style-type: none"> • Check for smooth operation. • Lubricate if necessary. 	-
Brake lever pivots	<ul style="list-style-type: none"> • Check for smooth operation. • Lubricate if necessary. 	-
Centerstand pivot	<ul style="list-style-type: none"> • Check for smooth operation. • Lubricate if necessary. 	-
Chassis fasteners	<ul style="list-style-type: none"> • Check all chassis fittings and fasteners. • Tighten if necessary. 	-
Fuel tank	<ul style="list-style-type: none"> • Check fuel level/Fill with fuel if necessary. 	7-9 ~ 7-10

ITEM	ROUTINE	PAGE
Lights, signals and switches	• Check for proper operation.	7-9

NOTE:

Pre-operation checks should be made each time the scooter is used. Such an inspection can be thoroughly accomplished in a very short time, and the added safety it assures is more than worth the time involved.

⚠ WARNING

1. The engine, exhaust pipe, and muffler will be very hot after the engine has been run. Be careful not to touch them or to allow any clothing item to contact them during inspection or repair.
2. If any item in the PRE-OPERATION CHECK is not working properly, have it inspected and repaired before operating the scooter. If necessary ask a Yamaha dealer.

Brakes

1. Brake levers

Check for correct free play in the brake levers and adjust if necessary. (See page 9-8 for details.) Make sure the brakes are working properly by checking at low speed shortly after starting out.

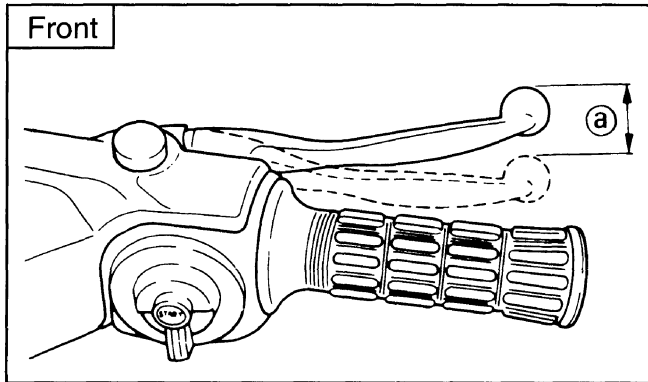

a. Free play

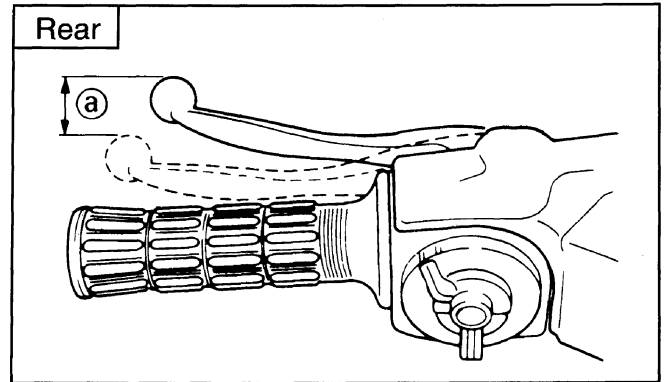

a. Free play

2. Check the brake shoes.
Refer to page 9-9.

EUU02201

NOTE: _____
When this brake service is necessary, consult a Yamaha dealer.

Throttle grip

Turn the throttle grip to see if it operates properly. Make sure the grip returns by spring force when released. There should be a free play of 1.5 ~ 3.5 mm (0.06 ~ 0.14 in) at the throttle grip. If the free play is incorrect, ask a Yamaha dealer to make this adjustment.

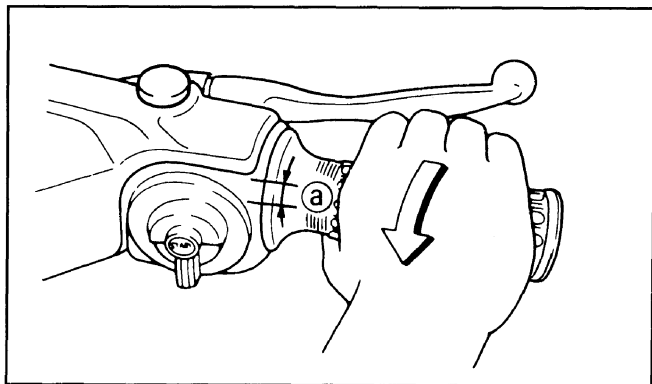

a. Free play

Engine oil

Make sure the engine oil is at the specified level. Fill with oil as necessary.

Recommended oil:

YAMALUBE 2-cycle oil or
air-cooled 2-stroke engine oil

Oil quantity:

Total amount

0.8 L (0.70 Imp qt, 0.85 US qt)

EUU04201

NOTE: _____

Be sure the cap is properly seated when replacing.

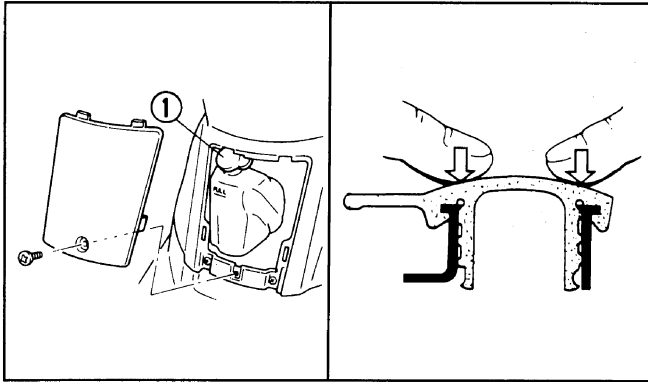

1. Oil tank cap

EAE50104

Air filter

The air filter prevents dirt from entering the engine. However, if the air filter is not properly maintained, dirt may enter the engine. The air filter should be cleaned regularly. Follow the periodic maintenance schedule on page 9-2.

CAUTION:

If the scooter is operated in dusty, muddy or wet conditions, check and/or clean the air filter each time before operating the scooter.

EAE96502

Tires

Check both front and rear tire pressures. Also check for nails, fragments of glass, or stones embedded in the tire treads. Check the run-out of each tire rim, and recondition as necessary. Ask a Yamaha dealer, if required.

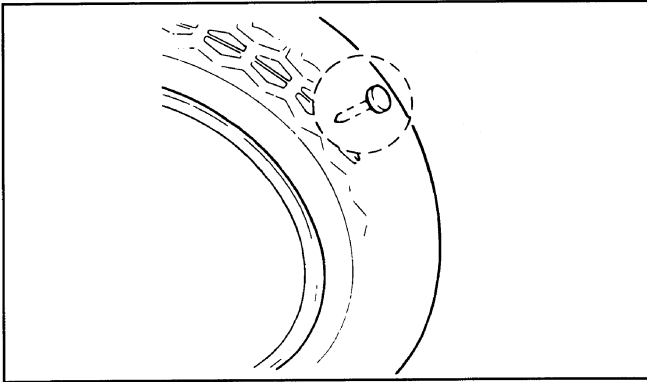

EUU73702

! WARNING

1. Proper loading is important for several characteristics of your scooter; such as handling, braking, performance and safety. **NEVER OVERLOAD YOUR SCOOTER.** Make sure the total weight of the cargo, rider, and accessories (fairing, saddlebags, etc. if approved for this model) does not exceed the maximum load of the scooter. Operation of an overloaded scooter could cause tire damage, an accident, or even injury.

2. Improper tire pressure greatly affects tire life and handling. Check the pressure of both tires prior to each trip and adjust properly if necessary. If tire pressure is too high, shocks from the road will not be damped and will be carried to the frame and handlebars, thus adversely affecting riding comfort. In addition, scooter stability will be poor when making a turn. If tire pressure is too low, tires will be deformed greatly, thus shortening tire life. When braking, the tires could slip over the wheel rims and the tubes could be damaged. Also, when turning a corner or going around a curve, the scooter could easily turn over.

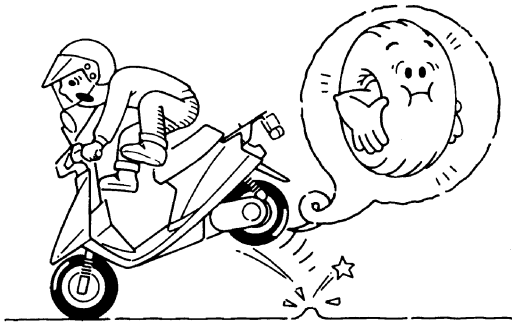

Too high



Too low

Cold tire pressure:

Front:

125 kPa (1.25 kgf/cm², 18 psi)

Rear:

175 kPa (1.75 kgf/cm², 25 psi)

Maximum loading limit*:

75 kg (165 lb)

* Load is the total weight of cargo, rider and accessories.

If tire treads are excessively worn, the scooter tends to slip or skid on wet roads or even on paved roads covered with dirt. If a tread depth shows crosswise lines, it means that the tire is worn to its limit. Replace the tire.

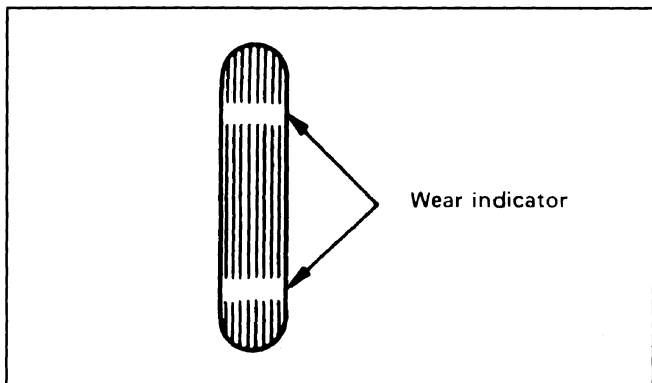

Minimum tire tread depth (front and rear)	1.0 mm (0.04 in)
--	------------------

EUU68001

! WARNING

It is dangerous to ride with a worn-out tire. When a tire tread begins to show lines, have a Yamaha dealer replace the tire immediately. Brakes, tires and related wheel parts replacement should also be left to a Yamaha dealer.

EAE93900

Accessories or replacement parts

EUU69700

! WARNING

This scooter is not designed to pull a trailer or to be attached to a sidecar. The accessories or replacement parts you choose for your scooter should be designed specifically for it, and they must be securely mounted to maintain the inherent stability of the original design. Genuine Yamaha Parts and Accessories are designed and tested to be compatible with your scooter. Please consider Genuine Yamaha Parts and Accessories before making an accessory purchase. Use of non-Yamaha-approved parts or accessories may cause loss of handling stability and riding safety. Since Yamaha cannot control the quality of parts or accessories manufactured by other companies, Yamaha cannot be held liable for any consequences caused by the use of items which have not been approved by Yamaha.

EAE71500

Lights, signals and switches

Check all the lights, meter lights and indicator lights to make sure they are in working condition.

Check the operation of the handlebar switches and main switch.

EAE80000

Fuel

Make sure there is sufficient fuel in the tank.

EUU61000

! WARNING

Do not overfill the fuel tank. Avoid spilling fuel on the hot engine. Do not fill the fuel tank above the bottom of the filler tube as shown in the illustration or it may overflow when the fuel heats up later and expands.

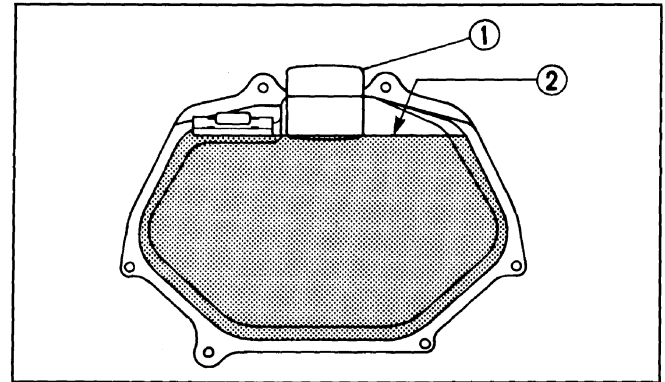

1. Filler tube

2. Fuel level

EUU39302

CAUTION:

Always wipe off spilled fuel immediately with a dry and clean soft cloth. Fuel may deteriorate painted surfaces or plastic parts.

Recommended fuel:

UNLEADED FUEL

Fuel tank capacity:

Total:

3.5 L (0.77 Imp gal, 0.92 US gal)

Your Yamaha engine has been designed to use regular unleaded gasoline with a pump octane number $([R+M]/2)$ of 86 or higher, or research octane number of 91 or higher. If knocking or pinging occurs, use a different brand of gasoline or premium unleaded fuel. Unleaded fuel will give you longer spark plug life and reduced maintenance cost. If unleaded gasoline is not available, then leaded regular gasoline can be used.

Gasohol

There are two types of gasohol; gasohol containing ethanol and that containing methanol. Gasohol containing ethanol can be used if ethanol content does not exceed 10%. Gasohol containing methanol is not recommended by Yamaha because it can cause fuel system damage or vehicle performance problems.

OPERATION AND IMPORTANT RIDING POINTS

EUU81800

WARNING

1. Before riding this scooter, become thoroughly familiar with all operating controls and their functions. Consult a Yamaha dealer regarding any control or function that you do not thoroughly understand.
2. Never start your engine or let it run for any length of time in a closed area. The exhaust fumes are poisonous and can cause loss of consciousness and death within a short time. Always operate your scooter in an area with adequate ventilation.
3. Before starting out, be sure to use the centerstand for safety.

EAF14303

Starting and warming up a cold engine

1. Turn the engine stop switch to "RUN".
2. Turn the main switch to " * ". If the oil level indicator light comes on, turn the main switch to "ON".

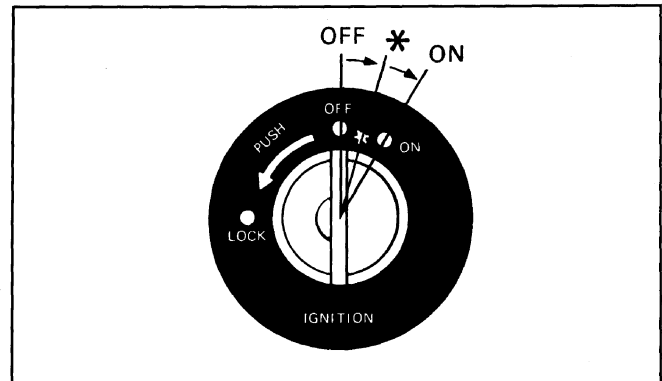

EUU43802

CAUTION:

If the oil level indicator light does not come on, ask a Yamaha dealer to inspect it.

3. Completely close the throttle grip and start the engine by pushing the start switch while applying the front or rear brake or by kicking the kick starter.

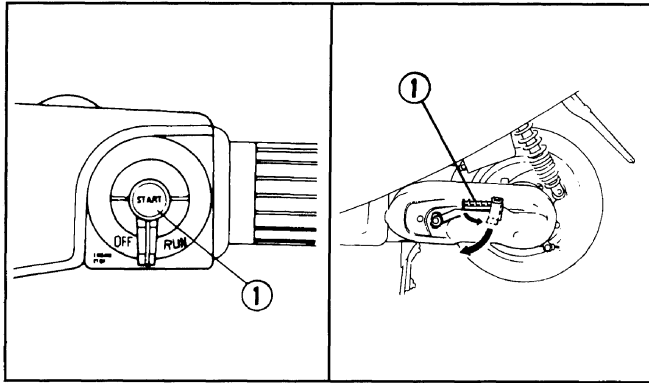

1. Start switch "START"

1. Kick starter

EUU10002

NOTE: _____

If the engine fails to start, release the start switch, wait a few seconds, then try again. Each attempt should be as short as possible to preserve the battery. Do not crank the engine more than 5 seconds on any one attempt. If the engine does not start with the starter motor, kick the kick starter to start the engine.

EUU17000

NOTE: _____

For maximum engine life, always warm up the engine about 1 ~ 3 minutes before riding your scooter. Never accelerate hard with a cold engine.

EUU31401

CAUTION: _____

See the "Engine break-in" section prior to operating the scooter for the first time.

Starting the scooter

After warming up the engine:

1. Hold the rear brake lever with your left hand, and push the scooter off the centerstand while holding the rear carrier with your right hand.

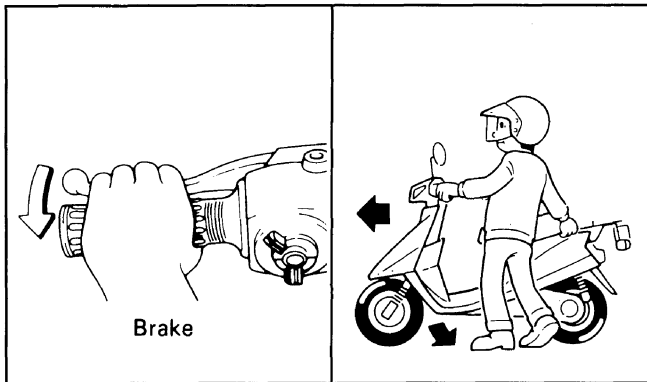

2. Sit astride the seat and check the mirror for its angle.
3. Check the oncoming traffic, and use a turn signal before entering traffic.
4. Turn out the throttle grip on the right handlebar slowly, and you can now start off. After starting off, turn off the flasher.

Acceleration

The speed can be adjusted by opening and closing the throttle grip. Turning it toward you increases the speed, and turning it in the opposite direction decreases the speed.

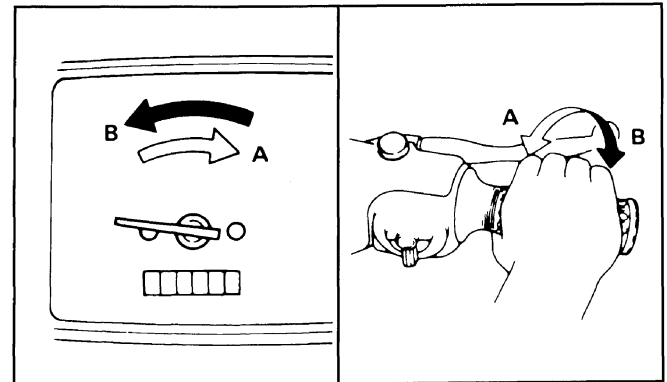

Braking

1. Close the throttle grip.
2. Apply both front and rear brakes simultaneously with light pressure and increase the pressure slowly.

⚠ WARNING

1. **Avoid hard or sudden braking. It may cause the scooter to skid or overturn.**
2. **Be sure to apply the brake carefully if leaning over to one side. Improper braking could lead to a skid.**
3. **Street car rails, metal plates on road construction sites, and man-hole covers become particularly slippery when they get wet. Cross them slowly and cautiously.**
4. **Braking on a wet road is very difficult.**
5. **Braking on a hill can be difficult. Proceed slowly when riding downhill.**

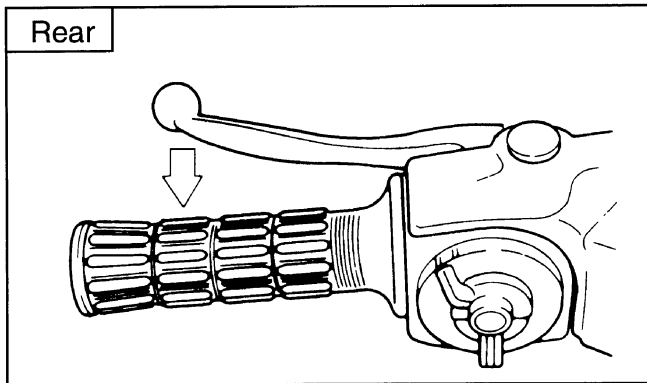
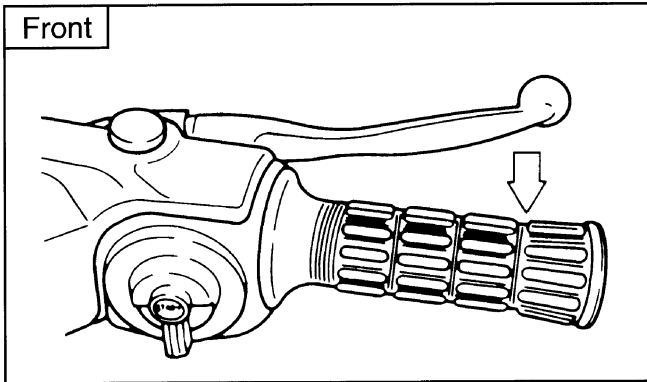

Engine break-in

There is never a more important period in the life of your scooter than the period between zero and 1,000 km (600 mi). For this reason we ask that you carefully read the following material. Because the engine is brand new, you must not put an excessive load on it for the first 1,000 km (600 mi). The various parts in the engine wear and polish themselves to the correct operating clearances. During this period, prolonged full throttle operation, or any condition which might result in excessive heating of the engine, must be avoided.

1. 0 ~ 150 km (0 ~ 90 mi):
Avoid operation above 1/3 throttle. Stop the engine and let it cool for 5 to 10 minutes after every hour of operation. Vary the speed of the scooter from time to time. Do not operate it at one set throttle position.

2. 150 ~ 500 km (90 ~ 300 mi):
Avoid prolonged operation above 1/2 throttle.

CAUTION:

After 500 km (300 mi) of operation, be sure to replace the transmission oil.

3. 500 ~ 1,000 km (300 ~ 600 mi):
Avoid cruising speeds in excess of 3/4 throttle.
4. 1,000 km (600 mi) and beyond:
Avoid prolonged full throttle operation. Vary speeds occasionally.

CAUTION:

If any engine trouble should occur during the break-in period, consult a Yamaha dealer immediately.

Parking

When parking the scooter, stop the engine and remove the ignition key.

⚠ WARNING

The exhaust system is hot. Park the scooter in a place where pedestrians or children are not likely to touch the scooter. Do not park the scooter on a slope or soft ground; the scooter may overturn.



Incorrect

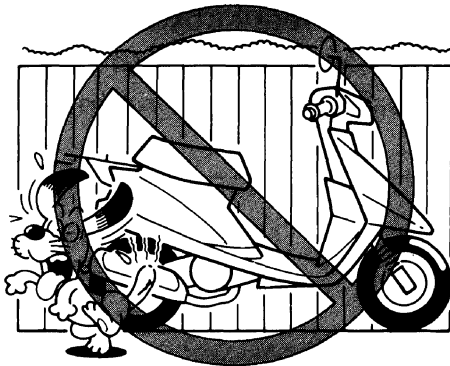

Incorrect

PERIODIC MAINTENANCE AND MINOR REPAIR

EAH00502

Periodic inspection, adjustment, and lubrication will keep your scooter in the safest and most efficient condition possible. Safety is an obligation of the scooter owner. The maintenance and lubrication schedule chart should be considered strictly as a guide to general maintenance and lubrication intervals. YOU MUST TAKE INTO CONSIDERATION THAT WEATHER, TERRAIN, GEOGRAPHICAL LOCATIONS, AND A VARIETY OF INDIVIDUAL USES ALL TEND TO DEMAND THAT EACH OWNER ALTER THIS TIME SCHEDULE TO SHORTER INTERVALS TO MATCH THE ENVIRONMENT. The most important points of scooter inspection, adjustment and lubrication are explained in the following pages.

EUU63200

WARNING

If you are not familiar with scooter service, this work should be done by a Yamaha dealer.

EUU76500

CAUTION:

This scooter is designed for use on paved road surface only. If this scooter is operated in abnormally dusty, muddy or wet conditions, the air filter should be cleaned or replaced more frequently. Otherwise, rapid engine wear may result. Consult a Yamaha dealer for proper maintenance intervals.

PERIODIC MAINTENANCE / LUBRICATION

Unit: Km(miles)

No.	ITEM	ROUTINE	BREAK-IN 500 (300)	EVERY	
				3,000 (2,000) or 6 months	6,000 (4,000) or 12 months
1	Spark plug	<ul style="list-style-type: none"> • Check condition. • Clean or replace if necessary. 	○	○	○
2	Air filter	<ul style="list-style-type: none"> • Clean. • Replace if necessary. 		○	○
3	* Carburetor	<ul style="list-style-type: none"> • Check idle speed. • Adjust if necessary. 	○		○
4	* Fuel line	<ul style="list-style-type: none"> • Check fuel hose and vacuum pipe for cracks or damage. • Replace if necessary. 		○	○
5	* Transmission oil	<ul style="list-style-type: none"> • Check oil leakage. • Correct if necessary. • Replace every 12,000 (8,000) or 24 months. (Warm engine before draining.) 	REPLACE	○	○
6	* Autolube pump	<ul style="list-style-type: none"> • Check operation. • Correct if necessary. • Bleed the air. 	○		○
7	Brakes	<ul style="list-style-type: none"> • Check operation. • Adjust if necessary. 		○	○
8	* Wheels	<ul style="list-style-type: none"> • Check damage/runout. • Replace if necessary. 		○	○
9	* Wheel bearings	<ul style="list-style-type: none"> • Check bearing assembly for looseness/damage. • Replace if damaged. 		○	○
10	* Steering bearings	<ul style="list-style-type: none"> • Check bearing assembly for looseness. • Correct if necessary. • Moderately repack every 12,000 (8,000) or 24 months** 	○	○	○

Unit: Km(miles)

No.	ITEM	ROUTINE	BREAK-IN 500 (300)	EVERY	
				3,000 (2,000) or 6 months	6,000 (4,000) or 12 months
11	* Rear shock absorber	<ul style="list-style-type: none"> • Check operation/oil leakage. • Repair if necessary. 		○	○
12	* V-belt	<ul style="list-style-type: none"> • Check damage and wear. • Replace if necessary. 			○
13	* Fittings and fasteners	<ul style="list-style-type: none"> • Check all chassis fittings and fasteners. • Tighten if necessary. 	○	○	○
14	* Centerstand	<ul style="list-style-type: none"> • Check operation. • Repair if necessary. 	○	○	○

Items marked with an asterisk (*) require special tools, data and technical skills for servicing.

Take the motorcycle to a Yamaha Dealer or refer to the Service Manual when servicing these items.

** : Medium weight wheel bearing grease.

EUU21900

NOTE: _____

The air filter needs more frequent service if you are riding in unusually wet or dusty areas.

Air filter element cleaning

This air filter should be cleaned at the specified intervals. It should be cleaned more frequently you are riding in unusually wet or dusty areas.

1. Remove the front cover.

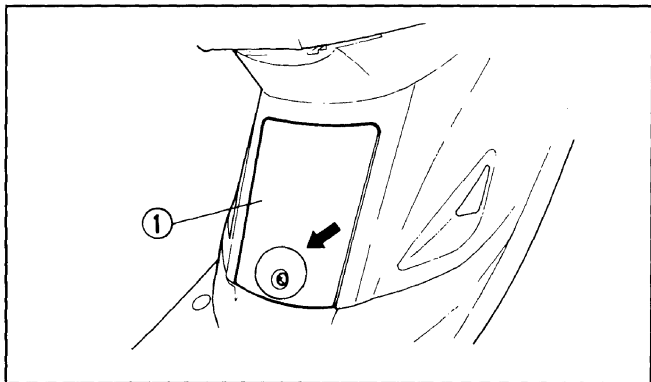

1. Front cover

2. Remove the air filter case assembly by removing the clamp and screws.

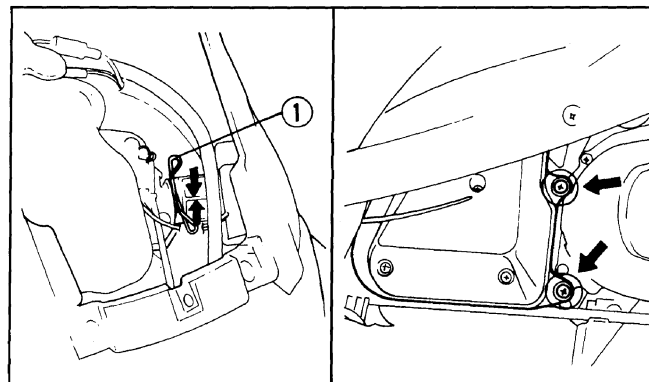

1. Clamp

3. Remove the air filter case cover by removing the screws.

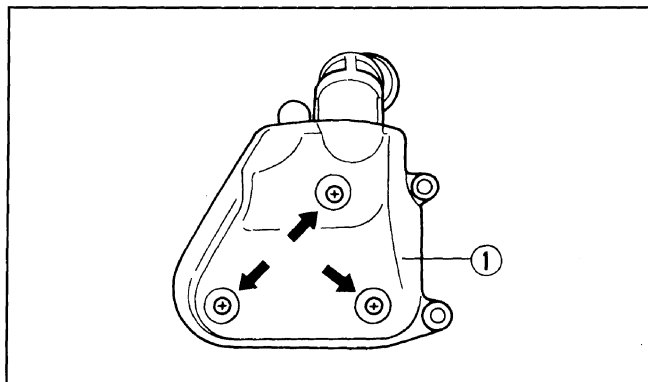

1. Air filter case cover

4. Remove the air filter from its case. Wash the air filter gently, but thoroughly, in solvent.

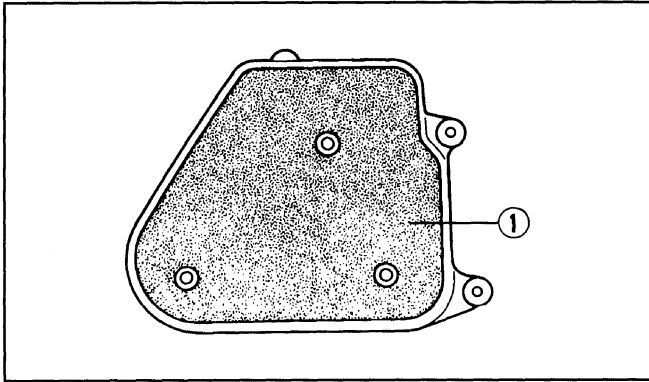

1. Air filter

EUU77000

⚠ WARNING

Use parts cleaning solvent only. Never use gasoline or low flash point solvents which may lead to a fire or explosion.

5. Squeeze the excess solvent out of the air filter and let it dry.

EUU42301

CAUTION:

Do not twist or wring out the air filter element. This could damage the foam material.

6. Apply oil to the entire surface of the air filter and squeeze out the excess oil. It should be damp, but not dripping with oil.

**Recommended oil:
YAMALUBE 2-cycle oil or
air-cooled, 2-stroke engine oil**

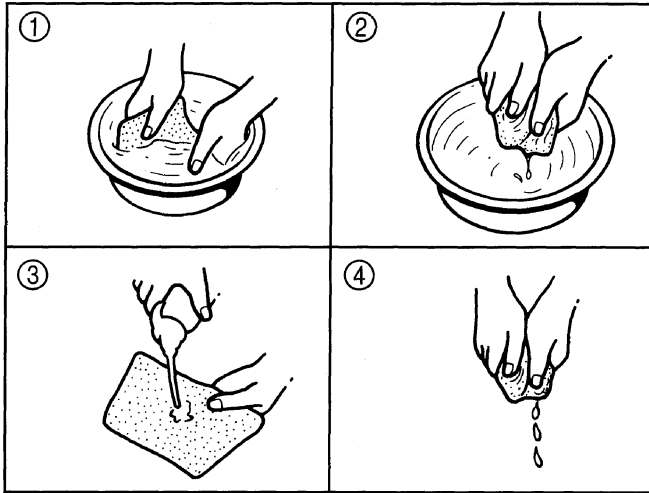

7. Install the air filter in its case. Be sure the sealing edge of the air filter perfectly matches with the sealing surface of its case so there is no air leakage.
8. Install the air filter case cover. Be sure that the seal is in place and that the bolts are tightened securely to avoid the possibility of unfiltered air entering the engine.

CAUTION:

The engine should never be run without the air filter element installed; excessive piston and/or cylinder wear may result.

9. Install the air filter case assembly.

NOTE:

Align the carburetor projection ① with air filter joint slot ②.

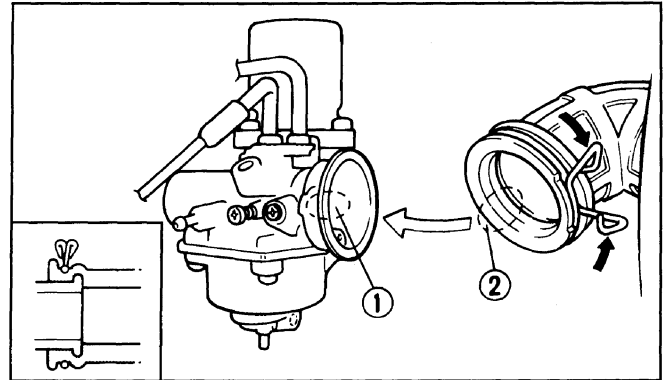

1. Carburetor projection

2. Air filter joint slot

Spark plug inspection

The spark plug is an important engine component and is easy to inspect. The condition of the spark plug can indicate the condition of the engine. The ideal color on the white insulator around the center electrode is a medium-to-light tan color for a scooter that is being ridden normally. Do not attempt to diagnose any problems yourself. Instead, take the scooter to a Yamaha dealer. You should periodically remove and inspect the spark plug because heat and deposits will cause the spark plug to slowly break down and erode. If electrode erosion becomes excessive, or if carbon and other deposits are excessive, you should replace the spark plug with the specified plug.

Specified spark plug:
BR7HS (NGK)

Before installing the spark plug, measure the electrode gap with a wire thickness gauge; adjust the gap to specification as necessary.

Spark plug gap:
0.5 ~ 0.6 mm (0.020 ~ 0.024 in)

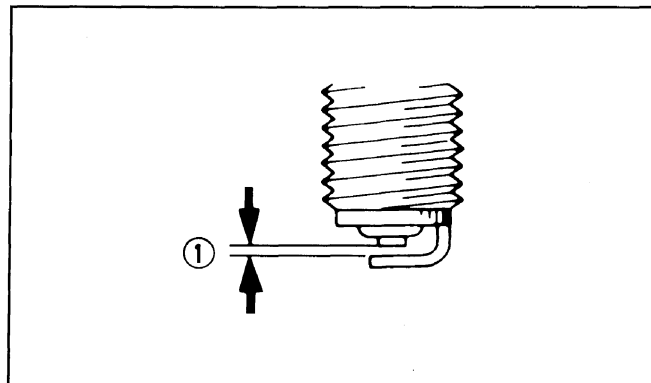

1. Spark plug gap

When installing the plug, always clean the gasket surface and use a new gasket. Wipe off any grime from the threads and tighten the spark plug to the specified torque.

Tightening torque:

Spark plug:

20 Nm (2.0 m·kg, 14 ft·lb)

EUU03802

NOTE:

If a torque wrench is not available when you are installing a spark plug, a good estimate of the correct torque is 1/4 to 1/2 turn past finger tight. Have the spark plug tightened to the specified torque as soon as possible.

EAH85803

Front and rear brake lever free play adjustment

The front and rear brake lever free play should be adjusted to 10 ~ 20 mm (0.4 ~ 0.8 in) at the brake lever end.

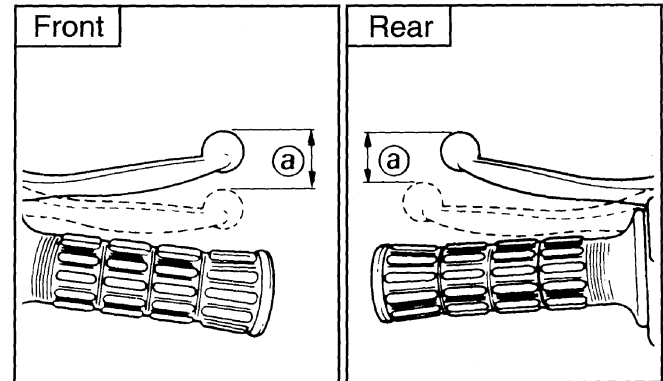

a. Free play

Make adjustment at the corresponding brake hub. Turn the adjusting nut in direction ⑥ to increase free play and in direction ⑤ to decrease free play.

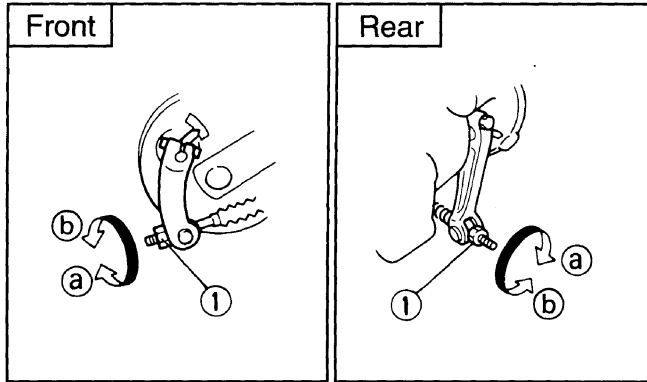

1. Adjusting nut

EUU73200

⚠ WARNING

When it is impossible to make the proper adjustment, ask a Yamaha dealer.

Checking the brake shoes

A wear indicator is provided on each brake. This indicator allows inspection of shoe wear without disassembling the brake. Apply the brake and inspect the position of the indicator. If the indicator reaches to the wear limit line, ask a Yamaha dealer to replace the shoes.

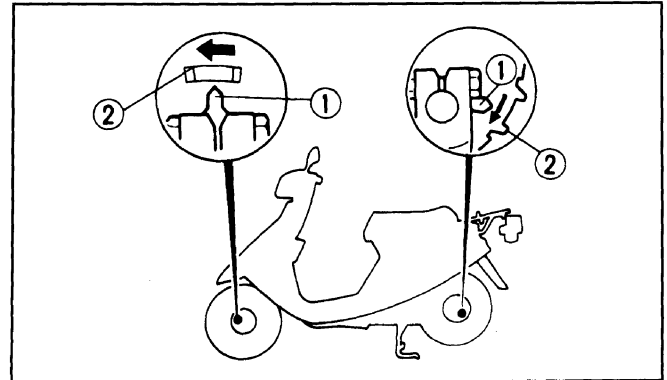

1. Wear indicator

2. Wear limit

Battery

This scooter is equipped with a sealed-type battery. Therefore it is not necessary to check the electrolyte or fill the battery with distilled water.

- If the battery seems to have discharged, consult a Yamaha dealer.
- If the scooter is equipped with optional electrical accessories, the battery tends to discharge more quickly, so be sure to recharge it periodically.

EUU43402

CAUTION:

Never try to remove the sealing caps of the battery cells. The battery will be damaged.

WARNING

Battery electrolyte is poisonous and dangerous, causing severe burns, etc. It contains sulfuric acid. Avoid contact with skin, eyes or clothing.

Antidote:

EXTERNAL: Flush with water.

INTERNAL: Drink large quantities of water or milk. Follow with milk of magnesia, beaten egg, or vegetable oil. Call a physician immediately.

EYES: Flush with water for 15 minutes and get prompt medical attention. Batteries produce explosive gases. Keep sparks, flame, cigarettes etc., away. Ventilate when charging or using in an enclosed space. Always shield your eyes when working near batteries.

KEEP OUT OF REACH OF CHILDREN.

Storage

When the scooter is not used for a month or longer, remove the battery, fully charge it and store it in a cool, dry place.

EUU43503

CAUTION:

- **Completely recharge the battery before storing. Storing a discharged battery can cause permanent battery damage.**
- **Use a battery charger designed for a sealed-type (MF) battery. Using a conventional battery charger will cause battery damage. If you do not have a sealed-type battery charger, contact your Yamaha dealer.**
- **Always make sure the connections are correct when reinstalling the battery.**

EAI92502

Fuse replacement

1. Remove the left side panel.

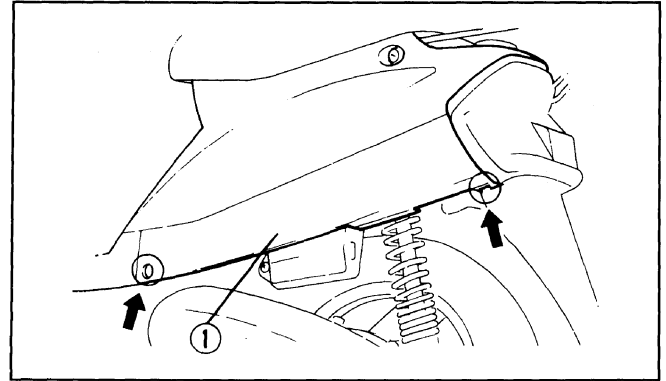

1. Left side panel

EUU14102

NOTE:

Pull the front of the left side panel outward and slide it backward to unhook the slots ③ on the side panel from the catches ② on the tail cowl.

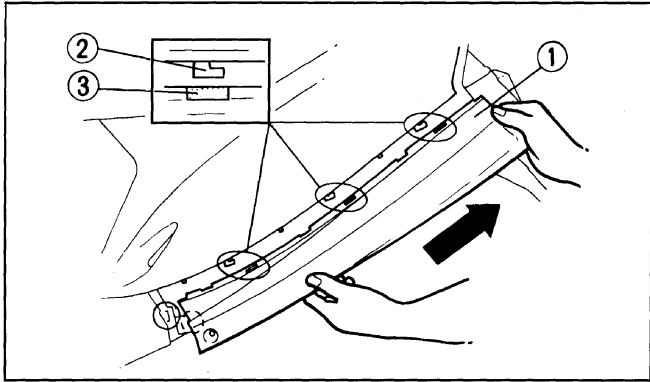

1. Left side panel 2. Catch 3. Slot

2. The fuse case is located beside the battery box.

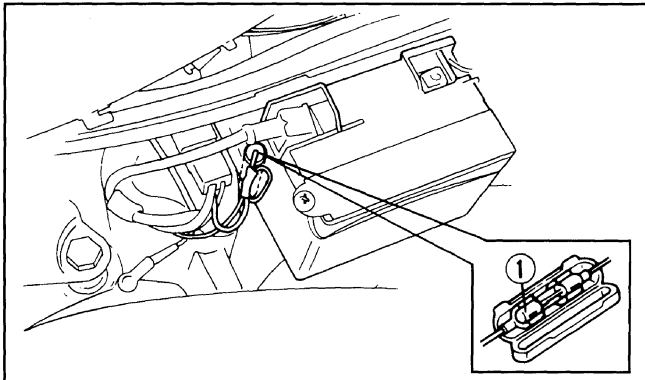

1. Fuse

3. If a fuse is blown, turn off the ignition switch and the switch of the circuit in question. Install a new fuse of specified amperage. Turn on the switches, and see if the electrical device operates. If the fuse immediately blows again, consult a Yamaha dealer.

EUU34400

CAUTION:

Do not use fuses of higher amperage rating than those recommended. Substitution of a fuse of improper rating can cause extensive electrical system damage and possibly a fire.

Specified fuse: 7A

Troubleshooting

Although Yamaha scooters receive a rigid inspection before shipment from the factory, trouble may occur during operation.

Any problem in the fuel, compression, or ignition systems can cause poor starting and loss of power. The troubleshooting chart describes a quick, easy procedure for making checks.

If your scooter requires any repair, bring it to a Yamaha dealer. The skilled technicians at a Yamaha dealership have the tools, experience, and know-how to properly service your scooter. Use only genuine Yamaha parts on your scooter. Imitation parts may look like Yamaha parts, but they are often inferior. Consequently, they have a shorter service life and can lead to expensive repair bills.

Troubleshooting chart

EUU66300

⚠ WARNING

Never check the fuel system while smoking or in the vicinity of an open flame.

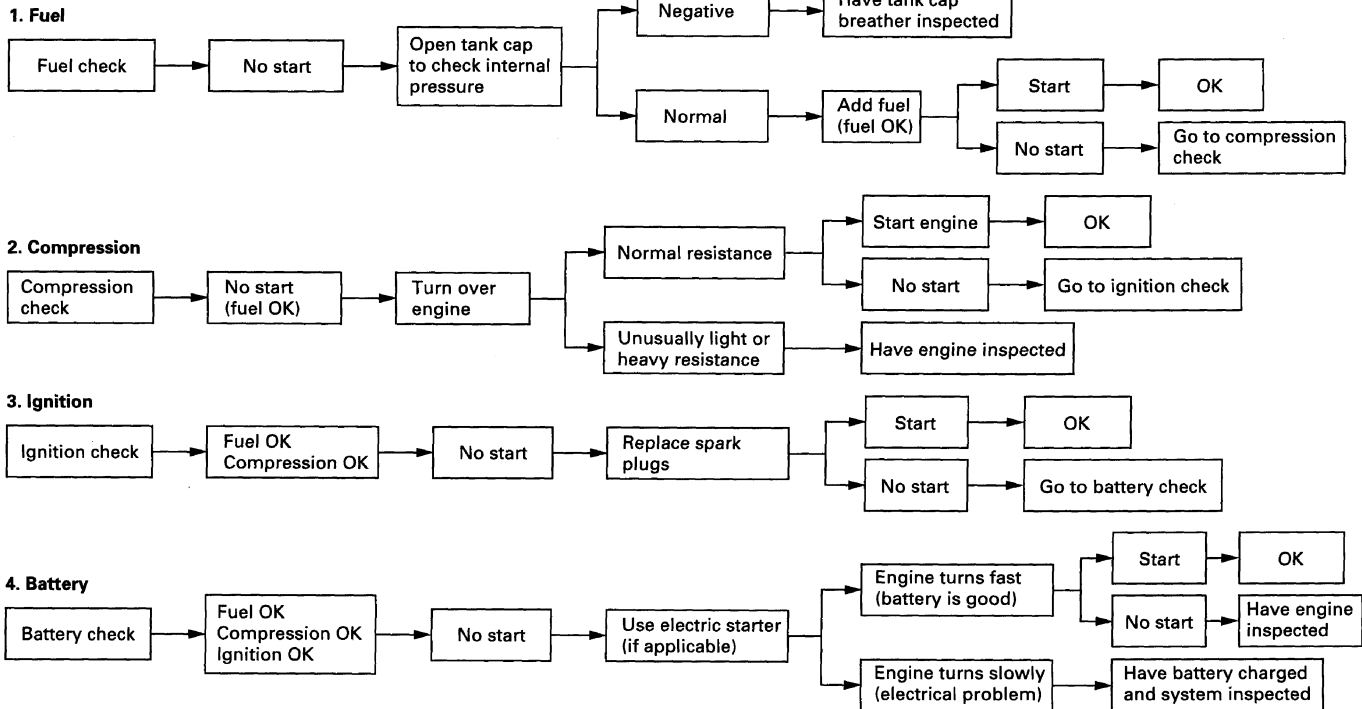

CLEANING AND STORAGE

EAK01104

A. CLEANING

Frequent, thorough cleaning of your scooter will not only enhance its appearance but will improve its general performance and extend the useful life of many components.

1. Before cleaning the scooter:
 - a. Block off the end of the exhaust pipe to prevent water entry; a plastic bag and strong rubber band may be used.
 - b. Make sure the spark plug and all filler caps are properly installed.
2. If the engine case is excessively greasy, apply degreaser with a paint brush. Do not apply degreaser to wheel axles.
3. Rinse the dirt and degreaser off with a garden hose. Use only enough pressure to do the job.

CAUTION

Excessive hose pressure may cause water seepage and deterioration of wheel bearings, front fork, brakes, transmission seals and electrical parts.

Many expensive repair bills have resulted from improper high pressure detergent applications such as those available in coin-operated car washers.

4. After riding on salted roads, wash the scooter with cold water immediately. Do not use warm water as it increases the chemical reaction of the salt.
5. Once the majority of the dirt has been hosed off, wash all surfaces with warm water and mild, detergent-type soap. An old toothbrush or bottle brush is handy for hard-to-get-at places.

6. Rinse the scooter off immediately with clean water and dry all surfaces with a chamois, clean towel, or soft absorbent cloth.
7. Clean the seat with a vinyl upholstery cleaner to keep the cover pliable and glossy.
8. Automotive-type wax may be applied to all painted and chrome-plated surfaces. Avoid combination cleaner-waxes. Many contain abrasives which may mar the paint or protective finish. When finished, start the engine and let it idle for several minutes.

EAK01502

B. STORAGE

Long term storage (60 days or more) of your scooter will require some preventive procedures to guard against deterioration. After thoroughly cleaning the scooter, prepare for storage as follows:

1. Fill the fuel tank with fuel and fuel stabilizer (if available).
2. Remove the spark plug, pour about one tablespoon of SAE 10W30 or 20W40 motor oil in the spark plug hole and reinstall the spark plug. Turn the engine over several times (with the ignition off) to coat the cylinder wall with oil.

EUU81400

WARNING

When using the starter motor to crank the engine, remove the spark plug wire, and ground it to prevent sparking.

3. Lubricate all control cables.
4. Block up the frame to raise both wheels off the ground.
5. Tie a plastic bag over the exhaust pipe outlet to prevent moisture from entering.

6. If storing in a humid or salt-air atmosphere, coat all exposed metal surfaces with a light film of oil. Do not apply oil to any rubber parts or the seat cover.
7. Remove the battery and fully charge it. Store it in a cool, dry place and recharge it once a month. Do not store the battery in an excessively warm or cold place (less than 0°C (30°F) or more than 30°C (90°F)). See page 9-11 for battery storage precautions.

EUU05800

NOTE: _____
Make any necessary repairs before storing the scooter.

SPECIFICATIONS

Model	CY50
Dimension: Overall length Overall width Overall height Seat height Wheel base Minimum ground clearance Minimum turning radius	1,645 mm (64.8 in) 630 mm (24.8 in) 980 mm (38.6 in) 710 mm (28.0 in) 1,115 mm (43.9 in) 80 mm (3.15 in) 1,600 mm (63.0 in)
Basic weight: With oil and full fuel tank	65 kg (143 lb)
Engine: Type Cylinder arrangement Displacement Bore × Stroke Compression ratio Starting system Lubrication system Engine oil type Capacity	Air cooled, 2-stroke Single cylinder, Forward inclined 49 cm ³ 40.0 × 39.2 mm (1.57 × 1.54 in) 7.2 : 1 Electric and Kick Starter Separate Lubrication (Yamaha Autolube) YAMALUBE 2-cycle oil or Air cooled 2-stroke engine oil 0.8 L (0.70 Imp qt, 0.85 US qt)

Model	CY50
Transmission oil: Type Oil capacity Periodic oil change Total amount	YAMALUBE 4 (10W30) or SAE 10W30 type SE motor oil 0.1 L (0.09 Imp qt, 0.11 US qt) 0.11 L (0.10 Imp qt, 0.12 US qt)
Air filter:	Wet Type Element
Fuel: Type Tank capacity	UNLEADED FUEL 3.5 L (0.77 Imp gal, 0.93 US gal)
Carburetor: Type/Quantity Manufacturer	Y14P/1 TEIKEI
Spark plug: Type Manufacturer Spark plug gap	BR7HS NGK 0.5 ~ 0.6 mm (0.020 ~ 0.024 in)
Clutch type:	Dry, Centrifugal Automatic
Transmission: Primary reduction system Primary reduction ratio Secondary reduction system Secondary reduction ratio Transmission type Operation	Helical gear 48/13 (3.692) Spur gear 36/12 (3.000) V-Belt centrifugal automatic type Automatic

Model	CY50
Chassis: Frame type Caster angle Trail	Steel tube underbone 26.5° 72 mm (2.83 in)
Tire: Type Size – Front Rear	Tubeless 80/90-10 34J 80/90-10 34J
Brake: Front brake type Front brake operation Rear brake type Rear brake operation	Drum brake Right hand operation Drum brake Left hand operation
Suspension: Front Rear	Telescopic fork Unit swing
Shock absorber: Front Rear	Coil spring Coil spring, oil damper
Wheel travel: Front Rear	42 mm (1.65 in) 42 mm (1.65 in)

Model	CY50
Electrical: Ignition system Generator system Battery type Battery voltage, capacity	C.D.I. Flywheel magneto YT4L-BS/GT4L-BS 12V, 3AH
Headlight type:	Bulb
Bulb voltage, wattage × quantity: Headlight Tail/brake light Flasher light Meter light	12V, 25W/25W × 1 12V, 5W/21W × 1 12V, 10W × 4 12V, 3.4W × 1
Indicator light voltage, wattage × quantity: High beam indicator light Oil level indicator light Turn indicator light	12V, 1.7W × 1 12V, 3.4W × 1 12V, 1.7W × 1

CONSUMER INFORMATION

Reporting safety defects

If you believe that your vehicle has a defect which could cause a crash or could cause injury or death, you should immediately inform the National Highway Traffic Safety Administration (NHTSA) in addition to notifying YAMAHA MOTOR CORP. U.S.A.. If NHTSA receives similar complaints, it may open an investigation, and if it finds that a safety defect exists in group of vehicles, it may order a recall and remedy campaign. However, NHTSA cannot become involved in individual problems between you, your dealer, or YAMAHA MOTOR CORP. U.S.A..

To contact NHTSA, you may either call the Auto Safety Hotline tollfree at 1-800-424-9393 (or 366-0123 in Washington, D.C. area) or write to: NHTSA, U.S. Department of Transportation, Washington, D.C. 20590. You can also obtain other information about motor vehicle safety from the Hotline.

SCOOTER NOISE REGULATION

TAMPERING WITH NOISE CONTROL SYSTEM PROHIBITED:

Federal law prohibits the following acts or the causing thereof: (1) The removal or rendering inoperative by any person other than for purposes of maintenance, repair, or replacement of any device or element of design incorporated into any new vehicle for the purpose of noise control prior to its sale or delivery to the ultimate purchaser or while it is in use or (2) the use of the vehicle after such device or element of design has been removed or rendered inoperative by any person.

“AMONG THOSE ACTS PRESUMED TO CONSTITUTE TAMPERING ARE THE ACTS LISTED BELOW”.

These acts include tampering with the following systems; i.e., modification, removal, etc.

Exhaust system	Muffler Exhaust pipe Silencer
Intake system	Air cleaner case Air cleaner element Intake duct

YAMAHA MOTOR CORPORATION, U.S.A. RIVA LIMITED WARRANTY

Yamaha Motor Corporation, U.S.A. hereby warrants that each new Yamaha Riva purchased from an authorized Yamaha Riva dealer in the continental United States will be free from defects in material and workmanship for the period of time stated herein, subject to certain stated limitations.

THE PERIOD OF WARRANTY for Yamaha Riva shall be one (1) year from the date of purchase, with no mileage limitation.

MODELS EXCLUDED FROM WARRANTY include those used for non-Yamaha-authorized renting, leasing, or other commercial purposes.

DURING THE PERIOD OF WARRANTY any authorized Yamaha motorcycle dealer will, free of charge, repair or replace, at Yamaha's option, any part adjudged defective by Yamaha due to faulty workmanship or material from the factory. Parts used in warranty repairs will be warranted for the balance of the product's warranty period. All parts replaced under warranty become property of Yamaha Motor Corporation U.S.A.

GENERAL EXCLUSIONS from this warranty shall include any failures caused by:

- a. Competition or racing use.
- b. Installation of parts or accessories that are not qualitatively equivalent to genuine Yamaha parts.
- c. Abnormal strain, neglect, or abuse.
- d. Lack of proper maintenance.
- e. Accident or collision damage.
- f. Damage due to improper transportation.

SPECIFIC EXCLUSIONS from this warranty shall include parts replaced due to normal wear or routine maintenance.

THE CUSTOMER'S RESPONSIBILITY under this warranty shall be to:

1. Operate and maintain the Riva as specified in the appropriate Owner's Manual, and
2. Give notice to an authorized Yamaha Riva dealer of any and all apparent defects within ten (10) days after discovery, and make the machine available at that time for inspection and repairs at such dealer's place of business.

WARRANTY TRANSFER: To transfer the warranty from the original purchaser to any subsequent purchaser, it is imperative that the machine be inspected and registered for warranty by an authorized Yamaha Riva dealer. In order for this warranty to remain in effect, this inspection and registration must take place within ten (10) days after transfer. An inspection and registration fee will be charged for this service.

EMISSIONS CONTROL SYSTEM WARRANTY

Yamaha Motor Corporation, U.S.A. also warrants to the ultimate purchaser and each subsequent purchaser of each Yamaha Riva covered by this warranty with a displacement of 50cc or greater, that the vehicle is designed, built, and equipped so as to conform at the time of sale with all U.S. emissions standards applicable at the time of manufacture and that it is free from defects in materials and workmanship which would cause it not to meet these standards within the periods listed immediately below. Failure other than those resulting from defects in material or workmanship which arise solely as a result of owner abuse and/or lack of proper maintenance are not covered by this warranty.

ENGINE DISPLACEMENT

50cc to 169cc

PERIOD

12,000 km (7,465 miles)
or five years, whichever occurs first

170cc to 279cc 18,000 km (11,185 miles)
or five years, whichever occurs first

280cc or over 30,000 km (18,641 miles)
or five years, whichever occurs first

YAMAHA MOTOR CORPORATION, U.S.A. MAKES NO OTHER WARRANTY OF ANY KIND, EXPRESSED OR IMPLIED. ALL IMPLIED WARRANTIES OF MERCHANTABILITY AND FITNESS FOR A PARTICULAR PURPOSE WHICH EXCEED THE OBLIGATIONS AND TIME LIMITS STATED IN THIS WARRANTY ARE HEREBY DISCLAIMED BY YAMAHA MOTOR CORPORATION, U.S.A. AND EXCLUDED FROM THIS WARRANTY.

SOME STATES DO NOT ALLOW LIMITATIONS ON HOW LONG AN IMPLIED WARRANTY LASTS, SO THE ABOVE LIMITATION MAY NOT APPLY TO YOU. ALSO EXCLUDED FROM THIS WARRANTY ARE ANY INCIDENTAL OR CONSEQUENTIAL DAMAGES INCLUDING LOSS OF USE. SOME STATES DO NOT ALLOW THE EXCLUSION OR LIMITATION OF INCIDENTAL OR CONSEQUENTIAL DAMAGES, SO THE ABOVE EXCLUSION MAY NOT APPLY TO YOU.

THIS WARRANTY GIVES YOU SPECIFIC LEGAL RIGHTS, AND YOU MAY ALSO HAVE OTHER RIGHTS WHICH VARY FROM STATE TO STATE.

YAMAHA MOTOR CORPORATION, U.S.A.
P. O. Box 6555
Cypress, California 90630

WARRANTY QUESTIONS AND ANSWERS

- Q. What costs are my responsibility during the warranty period?
- A. The customer's responsibility includes all costs of normal maintenance services, non-warranty repairs, accident and collision damage, and oil, oil filters, air filters, spark plugs, and brake shoes or pads.
- Q. What are some examples of "abnormal" strain, neglect, or abuse?
- A. These terms are general and overlap each other in areas. Specific examples include: Running the machine out of oil; sustained high-rpm, full-throttle use; operating the machine with a broken or damaged part which causes another part to fail; damage or failure due to improper or careless transportation and or tie down; and so on. If you have any specific questions on operation or maintenance, please contact your dealer for advice.
- Q. Does the warranty cover incidental costs such as towing or transportation due to a failure?
- A. No. The warranty is limited to repair of the machine itself.
- Q. May I perform any or all of the recommended maintenance shown in the Owner's Manual instead of having the dealer do them?
- A. Yes, if you are a qualified mechanic and follow the procedures specified in the Owner's and Service Manual. We do recommend, however, that items requiring special tools or equipment be done by a Yamaha Riva dealer.
- Q. Will the warranty be void or cancelled if I do not operate or maintain my new Riva exactly as specified in the Owner's Manual?
- A. No. The warranty on a new Riva cannot be "voided" or "cancelled." **However, if a particular failure is caused by operation or maintenance other than as shown in the Owner's Manual, that failure may not be covered under warranty.**
- Q. What responsibility does my dealer have under this warranty?
- A. Each Yamaha Riva dealer is expected to:
1. Completely set up every new machine before sale.
 2. Explain the operation, maintenance, and warranty requirements to your satisfaction at the time of sale, and upon your request at any later date.
 3. In addition, each Yamaha Riva dealer is held responsible for his setup, service and warranty repair work.
- Q. Is the warranty transferable to second owners?
- A. Yes. The remainder of the existing warranty can be transferred upon request. The unit has to be inspected and re-registered by an authorized Yamaha Riva dealer for the warranty coverage to remain effective.

CUSTOMER SERVICE

If your machine requires warranty service, you must take it to any authorized Yamaha Riva dealer within the continental United States. Be sure to bring your warranty registration identification or other valid proof of the original date of purchase. If a question or problem arises regarding warranty, first contact the owner of the dealership. Since all warranty matters are handled at the dealer level, this person is in the best position to help you. If you are still not satisfied and require additional assistance, please write:

YAMAHA MOTOR CORPORATION U.S.A.
CUSTOMER RELATIONS DEPARTMENT
P.O. Box 6555
Cypress, California 90630

When contacting Yamaha Motor Corporation, U.S.A. don't forget to include any important information such as names, addresses, model, engine serial number, dates, and receipts.

CHANGE OF ADDRESS

The federal government requires each manufacturer of a motor vehicle to maintain a complete, up-to-date list of all first purchasers against the possibility of a safety-related defect and recall. This list is compiled from the purchase registrations sent to Yamaha Motor Corporation, U.S.A. by the selling dealer at the time of your purchase.

If you should move after you have purchased your new Riva, please advise us of your new address by sending a postcard listing your Riva model name, engine serial number, dealer number (or dealer's name) as it is shown on your warranty identification, your name and new mailing address. Mail to:

YAMAHA MOTOR CORPORATION, U.S.A.
WARRANTY DEPARTMENT
P.O. Box 6555
Cypress, California 90630

This will ensure that Yamaha Motor Corporation, U.S.A. has an up-to-date registration record in accordance with federal law.

YAMAHA EXTENDED SERVICE (Y.E.S.)

Keep your Yamaha protected even after your warranty expires with genuine Yamaha Extended Service (Y.E.S.).

- Y.E.S. is designed and administered by Yamaha Motor Corporation to provide maximum owner satisfaction. You get uninterrupted factory-backed coverage for extra peace of mind.
- Y.E.S. is flexible. You choose the plan that's right for you: 12 months, 24 months, or 36 months beyond your warranty period.
- Y.E.S. is designed and administered by the same Yamaha people who handle your warranty — and it shows in the comprehensive coverage benefits. There are no mileage limitations. Coverage isn't limited to "moving parts" or the "drive train" like many other plans. And Y.E.S. covers manufacturing defects just like the warranty. See the sample contract at your Yamaha dealer to see how comforting uninterrupted factory-backed protection can be.
- You don't have to pay anything for covered repairs. There's no deductible to pay, and repairs aren't "pro-rated." You don't have any "out-of-pocket" expenses for covered repairs.

- In addition, Travel and Recreation Interruption Protection (TRIP) is included at no extra cost. TRIP gives you up to \$150 reimbursement per occurrence for any reasonable expenses you incur because your Yamaha needs covered service: replacement vehicle rental, emergency towing, phone calls, even food and lodging when you are away from home. This superb coverage goes into effect when you purchase Y.E.S., so it applies to any warranty repairs as well as covered repairs during your entire Y.E.S. plan period.
- Y.E.S. coverage is honored at any authorized Yamaha dealer nationwide.
- Y.E.S. coverage is transferrable to a new owner if you sell or trade-in. That can make your Yamaha much more valuable!

This excellent Y.E.S. plan coverage is only available to Yamaha owners like you, and only while your Yamaha is still within the Yamaha Limited Warranty period. So visit your authorized Yamaha dealer to get all the facts. He can show you how easy it is to protect your investment with Yamaha Extended Service.

We urge you to act now. You'll get the excellent benefits of TRIP coverage right away, and you'll rest easy knowing you'll have strong factory-backed protection even after your Yamaha Limited Warranty expires. You can also save money: Y.E.S. costs less within the first 90 days after you buy your Yamaha. See your dealer today!

A special note:

If visiting your dealer isn't convenient, contact Yamaha with your Primary ID number (your engine number). We'll be happy to help you get the Y.E.S. coverage you need.

Yamaha Service Marketing
P.O. Box 6555
Cypress, CA 90630
(714) 761-7631

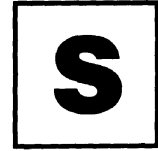
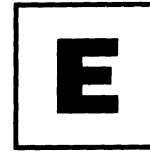
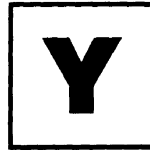

YAMAHA EXTENDED SERVICE