



WORKSHOP MANUAL

633424



LX 4tempi



WORKSHOP MANUAL

LX 4tempi

The descriptions and illustrations given in this publication are not binding. While the basic specifications as described and illustrated in this manual remain unchanged, PIAGGIO-GILERA reserves the right, at any time and without being required to update this publication beforehand, to make any changes to components, parts or accessories, which it considers necessary to improve the product or which are required for manufacturing or construction reasons.

Not all versions shown in this publication are available in all Countries. The availability of single versions should be checked at the official Piaggio sales network.

"© Copyright 2007 - PIAGGIO & C. S.p.A. Pontedera. All rights reserved. Reproduction of this publication in whole or in part is prohibited."

PIAGGIO & C. S.p.A. - After-Sales

V.le Rinaldo Piaggio, 23 - 56025 PONTEDERA (Pi)

WORKSHOP MANUAL

LX 4tempi

This workshop manual has been drawn up by Piaggio & C. Spa to be used by the workshops of Piaggio-Gilera dealers. This manual is addressed to Piaggio service mechanics who are supposed to have a basic knowledge of mechanics principles and of vehicle fixing techniques and procedures. Any important changes made to the vehicles or to specific fixing operations will be promptly reported by updates to this manual. Nevertheless, no fixing work can be satisfactory if the necessary equipment and tools are unavailable. It is therefore advisable to read the sections of this manual relating to specific tools, along with the specific tool catalogue.

N.B. Provides key information to make the procedure easier to understand and carry out.

CAUTION Refers to specific procedures to carry out for preventing damages to the vehicle.

WARNING Refers to specific procedures to carry out to prevent injuries to the repairer.



Personal safety Failure to completely observe these instructions will result in serious risk of personal injury.



Safeguarding the environment Sections marked with this symbol indicate the correct use of the vehicle to prevent damaging the environment.



Vehicle intactness The incomplete or non-observance of these regulations leads to the risk of serious damage to the vehicle and sometimes even the invalidity of the guarantee.



INDEX OF TOPICS

CHARACTERISTICS

CHAR

TOOLING

TOOL

MAINTENANCE

MAIN

TROUBLESHOOTING

TROUBL

ELECTRICAL SYSTEM

ELE SYS

ENGINE FROM VEHICLE

ENG VE

ENGINE

ENG

SUSPENSIONS

SUSP

BRAKING SYSTEM

BRAK SYS

CHASSIS

CHAS

PRE-DELIVERY

PRE DE

TIME

TIME

INDEX OF TOPICS

CHARACTERISTICS

CHAR

Rules

Safety rules

- If work can only be done on the vehicle with the engine running, make sure that the premises are well-ventilated, using special extractors if necessary; never let the engine run in an enclosed area. Exhaust fumes are toxic.
 - The battery electrolyte contains sulphuric acid. Protect your eyes, clothes and skin. Sulphuric acid is highly corrosive; in the event of contact with your eyes or skin, rinse thoroughly with abundant water and seek immediate medical attention.
 - The battery produces hydrogen, a gas that can be highly explosive. Do not smoke and avoid sparks or flames near the battery, especially when charging it.
 - Fuel is highly flammable and it can be explosive given some conditions. Do not smoke in the working area, and avoid open flames or sparks.
 - Clean the brake pads in a well-ventilated area, directing the jet of compressed air in such a way that you do not breathe in the dust produced by the wear of the friction material. Even though the latter contains no asbestos, inhaling dust is harmful.
-

Maintenance rules

- Use original PIAGGIO spare parts and lubricants recommended by the Manufacturer. Non-original or non-conforming spares may damage the vehicle.
 - Use only the appropriate tools designed for this vehicle.
 - Always use new gaskets, sealing rings and split pins upon refitting.
 - After removal, clean the components using non-flammable or low flash-point solvent. Lubricate all the work surfaces except the tapered couplings before refitting.
 - After refitting, make sure that all the components have been installed correctly and work properly.
 - For removal, overhaul and refit operations use only tools with metric measures. Metric bolts, nuts and screws are not interchangeable with coupling members with English measurement. Using unsuitable coupling members and tools may damage the scooter.
 - When carrying out maintenance operations on the vehicle that involve the electrical system, make sure the electric connections have been made properly, particularly the ground and battery connections.
-

Vehicle identification

VEHICLE IDENTIFICATION

Specification	Desc./Quantity
Chassis prefix	ZAPC383000001001
Engine prefix	C383M

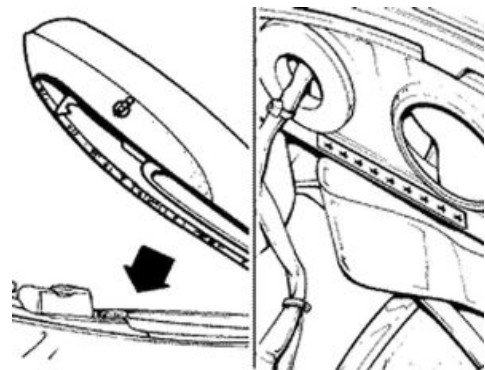

Dimensions and mass

WEIGHT AND DIMENSIONS

Specification	Desc./Quantity
Dry weight	102 ± 5
Width	740 mm
Length	1755 mm
Wheel base	1290 mm.
Overall height	1140 mm

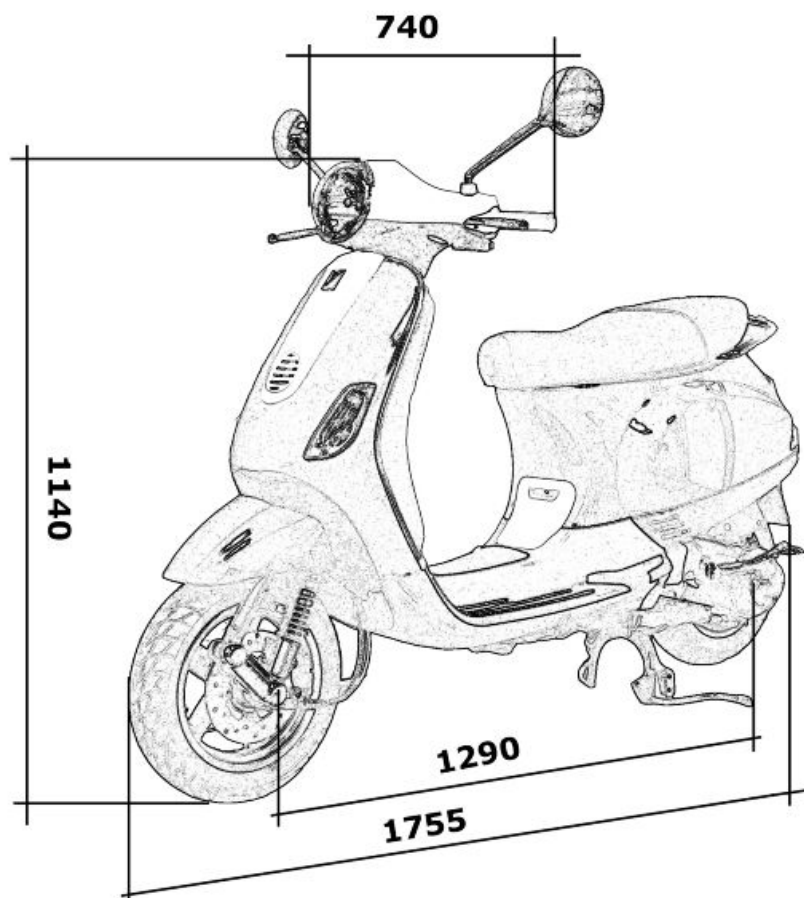

Engine

ENGINE

Specification	Desc./Quantity
Type	Single-cylinder, 4-stroke, Piaggio Hi-Per 4
Bore	39 mm
Stroke	41,8 mm
Cubic capacity	49.93 cm ³
Compression ratio	11,5 ÷ 12 : 1
Timing system	single overhead camshaft, driven by a chain to the left side.
Vacuum-type carburettor	KEIHIN CVK Ø 18 mm
CO adjustment	3.2% ± 0.5
Engine idle speed	1900 ÷ 2000 rpm
Air filter	Sponge impregnated with fuel mixture (50% SELENIA air filter oil and 50% unleaded petrol).
Starting system	electric starter/kickstarter
Lubrication	engine lubrication with lobe pump (in the crankcase) driven by a chain. Mesh prefilter and centrifugal on the crankshaft
Fuel supply	Gravity feed, with unleaded petrol (with a minimum octane rating of 95) with carburettor.
Max. power (crankshaft)	2,5 KW (3,4 CV) at 6500 rpm.
Cooling system	forced coolant circulation system
Valve clearance (cold engine)	intake 0.10 mm

Specification	Desc./Quantity
	discharge 0.15 mm

Transmission

TRANSMISSION

Specification	Desc./Quantity
Transmission	With automatic expandable pulley variator, torque server, V belt, automatic clutch, gear reduction unit.

Capacities

CAPACITY

Specification	Desc./Quantity
Fuel tank (including 2 litre reserve)	~ 8,5 l
Rear hub oil	85 cc
Engine oil	~ 850 cc

Electrical system

ELECTRICAL SYSTEM:

Specification	Desc./Quantity
Type of ignition	Capacitive discharge type electronic ignition, with incorporated high voltage coil
Ignition advance variable, with microprocessor (before T.D.C.)	8° at 1000 + 2000 rpm - 21° at 4000 + 7000 rpm
Spark plug	NGK CR 8EB
Battery	12V-9Ah
Fuse	10A
Generator	single-phase alternating current

Frame and suspensions

FRAME AND SUSPENSIONS

Specification	Desc./Quantity
Type	Unitised body made of stamped plate
Front suspension	Single arm suspension with swinging arm articulated to the steering tube. Hydraulic double-acting shock absorber and coaxial spring
Front suspension stroke	70 mm
Trail (suspension rebounded/compressed)	71/68 mm
Rear suspension	Single hydraulic double-acting shock absorber, helicoidal coaxial spring. Chassis engine support with swinging arm.
Rear suspension travel:	83.5 mm

Brakes

Wheels and tyres

WHEELS AND TYRES

Specification	Desc./Quantity
Front tyre size	110/70"-11"
Rear tyre size	120/70-10"
Front tyre pressure	1.6 bar
Rear tyre pressure:	2 bar
Light alloy rims (Front rim)	2.50" x 11"
Light alloy rims (rear rim)	3.00 x 10"

N.B.

CHECK AND ADJUST TYRE PRESSURE WITH TYRES AT AMBIENT TEMPERATURE. ADJUST PRESSURE ACCORDING TO THE WEIGHT OF THE RIDER AND ACCESSORIES.

Carburettor

50cc Version

Kehin

KEHIN CARBURETTOR

Specification	Desc./Quantity
Type	CVK 18
Throttle valve diameter:	Ø 18,5
Choke diameter	Ø 17
Marking on body:	Z61B
Maximum thrust	75
Maximum air thrust (on body)	Ø1,1
Marking on conical needle:	NGBA
Throttle spring:	100 ÷ 159 gr
Minimum thrust	35
Idle air jet (on body):	Ø 1,4
Initial opening - idle mixture screw:	1 3/4
Starter jet	40
Starter air nozzle (on the body):	Ø 1.5
Choke needle travel:	11,5 mm

Tightening Torques

STEERING

Name	Torque in Nm
Upper steering ring nut	30 ÷ 40
Lower steering ring nut	8 ÷ 10
Handlebar fastening screw	50 ÷ 55 Nm

FRAME ASSEMBLY

Name	Torque in Nm
Engine-swinging arm bolt	33 ÷ 41
Floating arm-frame pin	44 ÷ 52
Frame-rear shock absorber nut	20 ÷ 25
Shock absorber-engine nut	33 ÷ 41
Rear wheel nut	104 ÷ 126
Speedometer gear plate fixing screw	4 ÷ 6

FRONT SUSPENSION

Name	Torque in Nm
Shock absorber upper nut	20 ÷ 30
Front wheel axle nut	75 ÷ 90
Shock absorber upper bracket bolts	20 ÷ 25
Wheel rim screws	20 ÷ 25
Shock absorber lower bolts (°)	20 ÷ 27

(°)Tighten these two bolts after tightening the shock absorber central upper nut.

N.B.

FOR INFORMATION ON SAFETY TIGHTENINGS, REFER TO CHAPTER «PRE-CONSIGNMENT CHECKS».

FRONT BRAKE

Name	Torque in Nm
Brake fluid pump-hose fitting	8 ÷ 12
Brake fluid pipe-calliper fitting	20 ÷ 25
Screw tightening calliper to the support	20 ÷ 25
Brake disc screw	5 ÷ 6.5
Oil bleed valve (on the calliper)	10 ÷ 12
Handlebar pump	7 ÷ 10

ENGINE ASSEMBLY

Name	Torque in Nm
Spark plug:	10 ÷ 15 Nm
Screw fixing floating head	6 ÷ 7
Head-cylinder stud bolt nuts	6 ÷ 7 + 90° + 90° *
Screws fixing head and cylinder to crankcase	8 ÷ 10
Chain tightener pad screw	5 ÷ 7 Nm
Timing chain tensioner central screw	5 - 6
Camshaft pulley screw	12 ÷ 14
Rocking lever axle and camshaft bearing screw	3 ÷ 4 Nm
Rocker-arm adjusting nuts:	7 ÷ 9 Nm
Engine oil pre-filter cover:	25 ÷ 28 Nm
Engine oil drainage cap	25 ÷ 28
Flywheel nut	40 to 44 N.m
Stator screws	3 ÷ 4
Pick-up screws	3 ÷ 4
Oil pump bulkhead screw	4 ÷ 5
Timing chain/oil pump compartment cover screws	4 ÷ 5
Oil decantation labyrinth sheet screws	7 ÷ 8
Oil pump crown screw	8 ÷ 10
Screws fixing oil pump to the crankcase	5 - 6
Oil sump screws	8 ÷ 10 Nm

Name	Torque in Nm
Inlet manifold screw	7 ÷ 9
Manifold/carburettor clamp screw	1,2 ÷ 1,5
Screws fixing cables to starter	1.5 ÷ 2.5
Starter motor screws	11 ÷ 13
Transmission cover screws	11 ÷ 13
Start-up lever screw	11 ÷ 13
Crankcase cooling cover screw	2 ÷ 2.5
Clutch assembly nut	55 ÷ 60
Crankshaft pulley nut	18 to 20 + 90° N.m
Driven pulley shaft nut	40 to 44 Nm
Hub oil drainage screw	3 ÷ 5 Nm
Rear hub cover screws	11 ÷ 13
Half casing union screw	8 ÷ 10

*When new stud bolts are assembled, tighten them with 3 turns at 90° after the first tightening at 6-7 N·m, therefore 6-7 N·m + 90° + 90° + 90°, in a crosswise manner.

Overhaul data

Assembly clearances

Cylinder - piston assy.

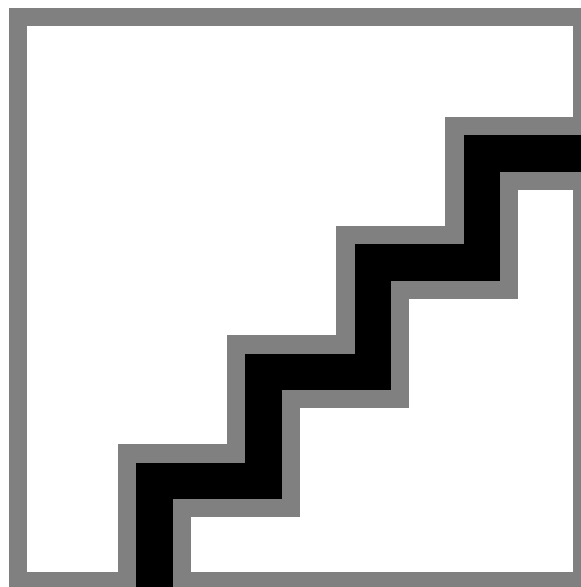

CONNECTION PISTON AND CYLINDER

Name	Initials	Cylinder	Piston	Play on fitting
Cylinder (with asso piston/right way)	A	38,993 ÷ 39,000	38,954 ÷ 38,961	0.032 ÷ 0.046
Cylinder (with shiram piston)	A	38,993 ÷ 39,000	38,949 ÷ 38,956	0.037 ÷ 0.051
Cylinder (with asso piston/right way)	B	39,000 ÷ 39,007	38,961 ÷ 38,968	0.032 ÷ 0.046

Name	Initials	Cylinder	Piston	Play on fitting
Cylinder (with shiram piston)	B	39,000 ÷ 39,007	38,956 ÷ 38,966	0,037 ÷ 0,051
Asso piston/right way (with asso cylinder/right way)	C	39,007 ÷ 39,014	38,968 ÷ 38,975	0,032 ÷ 0,046
Asso piston/right way (with shiram cylinder)	C	39,007 ÷ 39,014	38,963 ÷ 38,970	0,037 ÷ 0,051
Shiram piston (with asso cylinder/right way)	D	39,014 ÷ 39,021	38,975 ÷ 38,982	0,032 ÷ 0,046
Shiram piston (with shiram cylinder)	D	39,014 ÷ 39,021	38,970 ÷ 38,977	0,037 ÷ 0,051
Cylinder first uprat.	A1	39,193 ÷ 39,200	39,154 ÷ 39,161	0,032 ÷ 0,046
Cylinder first uprat.	B1	39,200 ÷ 39,207	39,161 ÷ 39,168	0,032 ÷ 0,046
Piston first uprat.	C1	39,207 ÷ 39,214	39,168 ÷ 39,175	0,032 ÷ 0,046
Piston first uprat.	D1	39,214 ÷ 39,221	39,175 ÷ 39,182	0,032 ÷ 0,046
Cylinder second uprat.	A2	39,393 ÷ 39,400	39,354 ÷ 39,361	0,032 ÷ 0,046
Cylinder second uprat.	B2	39,400 ÷ 39,407	39,361 ÷ 39,368	0,032 ÷ 0,046
Piston second uprat.	C2	39,407 ÷ 39,414	39,368 ÷ 39,375	0,032 ÷ 0,046
Piston second uprat.	D2	39,414 ÷ 39,421	39,375 ÷ 39,382	0,032 ÷ 0,046
Cylinder third uprat.	A3	39,593 ÷ 39,600	39,554 ÷ 39,561	0,032 ÷ 0,046
Cylinder third uprat.	B3	39,600 ÷ 39,607	39,561 ÷ 39,568	0,032 ÷ 0,046
Piston third uprat.	C3	39,607 ÷ 39,614	39,568 ÷ 39,575	0,032 ÷ 0,046
Piston third uprat.	D3	39,614 ÷ 39,621	39,575 ÷ 39,582	0,032 ÷ 0,046

Piston rings

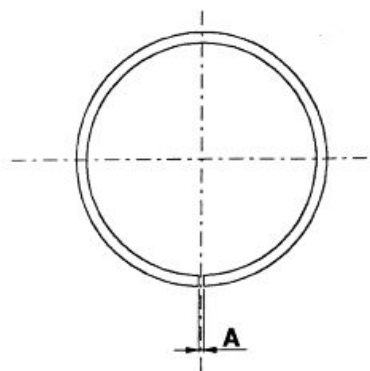

UPRATING TABLE

Name	Description	Dimensions	Initials	Quantity
1° Compression lining		39 x 1	A	0,08 ÷ 0,20
2° Compression lining		39 x 1	A	0,05 ÷ 0,20
Scraper ring lining		39 x 2	A	0,20 ÷ 0,70

Name	Description	Dimensions	Initials	Quantity
1° Compression lining 1° greater		39,2 x 1	A	0,08 ÷ 0,20
2° Compression lining 1° greater		39,2 x 1	A	0,05 ÷ 0,20
Scraper ring lining 1° greater		39,2 x 2	A	0,20 ÷ 0,70
1° Compression lining 2° greater		39,4 x 1	A	0,08 ÷ 0,20
2° Compression lining 2° greater		39,4 x 1	A	0,05 ÷ 0,20
Scraper ring lining 2° greater		39,4 x 2	A	0,20 ÷ 0,70
1° Scraper ring lining 3° greater		39,6 x 1	A	0,08 ÷ 0,20
2° Scraper ring lining 3° greater		39,6 x 1	A	0,05 ÷ 0,20
Scraper ring lining 3° greater		39,6 x 2	A	0,20 ÷ 0,70

Crankcase - crankshaft - connecting rod

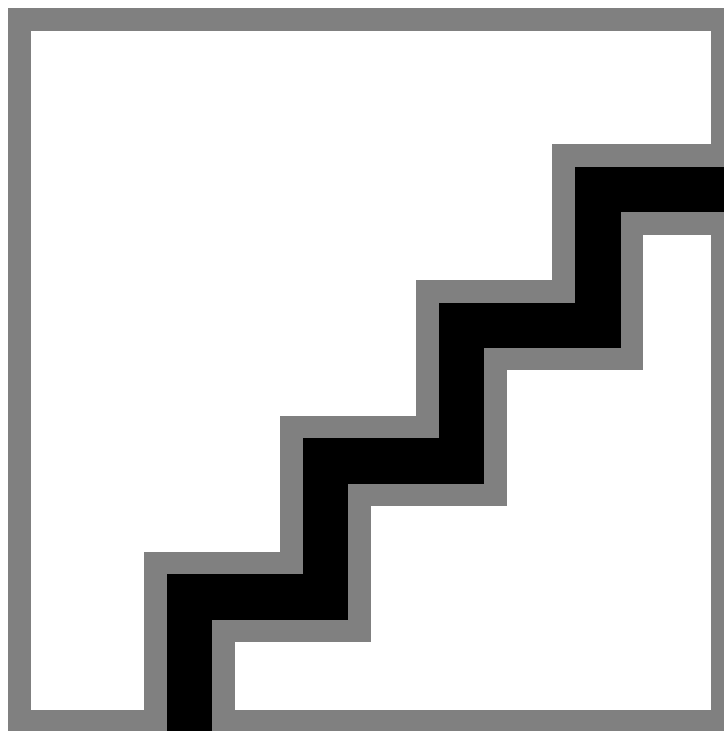

END PLAY BETWEEN DRIVING SHAFT AND CONNECTING ROD

Name	Description	Dimensions	Initials	Quantity
Transmission side half shaft		14 +0 -0.005	A	
Flywheel side half shaft		16 +0 -0.005	B	
Connecting rod		14.8 +0.05 -0	C	

Name	Description	Dimensions	Initials	Quantity
Spacing tool		45,00 / assembly games D = 0,15 ÷ 0,30	E	

Slot packing system

N.B.

MEASUREMENT "A" TO BE TAKEN IS A VALUE OF PISTON RE-ENTRY, IT INDICATES BY HOW MUCH THE PLANE FORMED BY THE PISTON CROWN FALLS BELOW THE PLANE FORMED BY THE TOP OF THE CYLINDER. THE FURTHER THE PISTON GETS INSIDE THE CYLINDER, THE THINNER THE HEAD GASKET TO BE APPLIED SHOULD BE (TO RECOVER THE COMPRESSION RATIO) AND VICE VERSA.

Characteristic

Shimming system to control the compression ratio

CR: 11.1 ÷ 12.9

PISTON PROTRUSION CHECK

Name	Measure A	Thickness
shimming_1	0.05 ÷ 0.25	0.35
shimming_2	0.25 ÷ 0.40	0.25

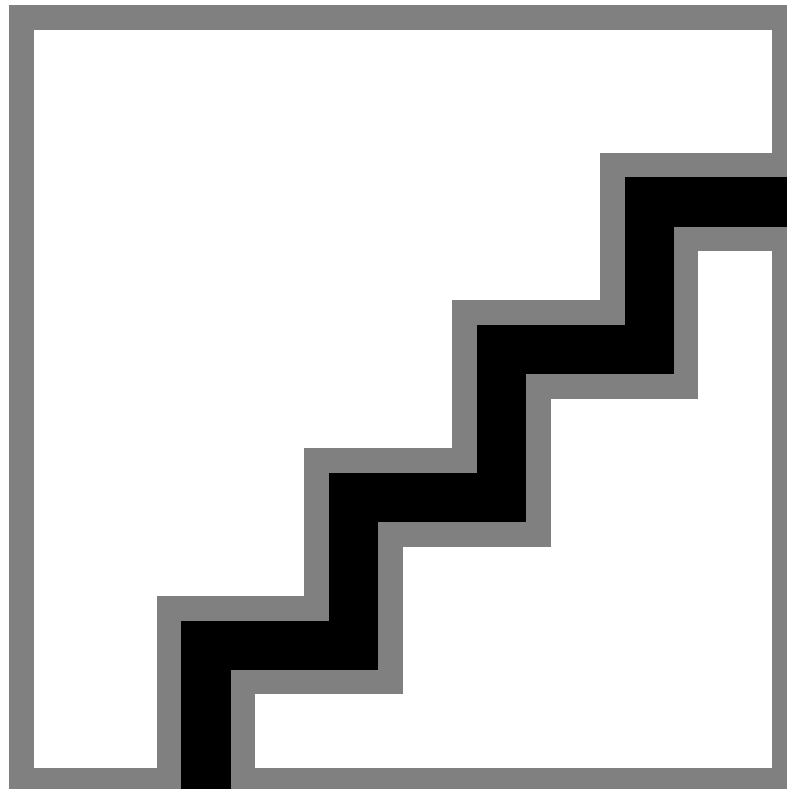

N.B.

MEASUREMENT "A" TO BE TAKEN IS A VALUE OF PISTON RE-ENTRY, IT INDICATES BY HOW MUCH THE PLANE FORMED BY THE PISTON CROWN FALLS BELOW THE PLANE FORMED BY THE TOP OF THE CYLINDER. THE FURTHER THE PISTON GETS INSIDE THE CYLINDER, THE THINNER THE HEAD GASKET TO BE APPLIED SHOULD BE (TO RECOVER THE COMPRESSION RATIO) AND VICE VERSA.

Characteristic

Shimming system to control the compression ratio

CR: 11.1 ÷ 12.9

PISTON PROTRUSION CHECK

Name	Measure A	Thickness
shimming_1	0.05 ÷ 0.25	0.35
shimming_2	0.25 ÷ 0.40	0.25

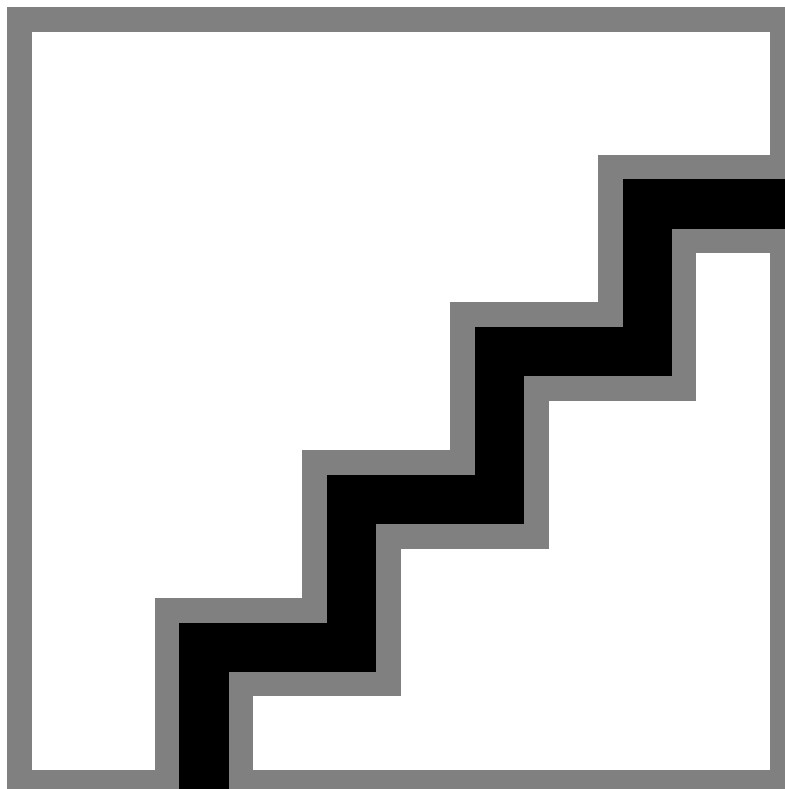

Products

TABLE OF RECOMMENDED PRODUCTS

Product	Description	Specifications
AGIP ROTRA 80W-90	Rear hub oil	SAE 80W/90 Oil that exceeds the requirements of API GL3 specifications
AGIP CITY HI TEC 4T	Oil to lubricate flexible transmissions (brakes, throttle control and odometer)	Oil for 4-stroke engines
AGIP FILTER OIL	Oil for air filter sponge	Mineral oil with specific additives for increased adhesiveness
AGIP CITY HI TEC 4T	Engine oil	SAE 5W-40, API SL, ACEA A3, JASO MA Synthetic oil
AGIP GREASE MU3	Grease for odometer transmission gear case	Soap-based lithium grease with NLGI 3; ISO-L-XBCHA3, DIN K3K-20
AGIP BRAKE 4	Brake fluid	FMVSS DOT4 Synthetic fluid

Product	Description	Specifications
MONTBLANC MOLYBDENUM GREASE	Grease for driven pulley shaft adjusting ring and movable driven pulley housing	Molybdenum disulphide grease
AGIP GREASE PV2	Grease for steering bearings, bolt seatings for swinging arms and contact surface of driven pulley spring (only pulley side)	Lithium soap and zinc oxide grease NLGI 2; ISO-L-XBCIB2
AGIP GP 330	Grease for brake levers, throttle	White calcium complex soap-based spray grease with NLGI 2; ISO-L-XBCIB2

INDEX OF TOPICS





TOOLING

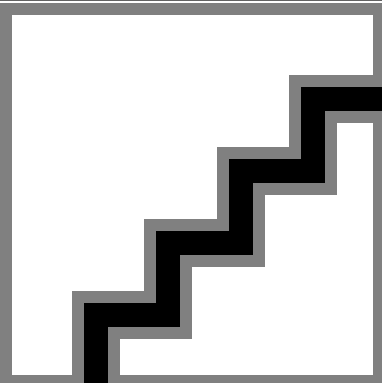
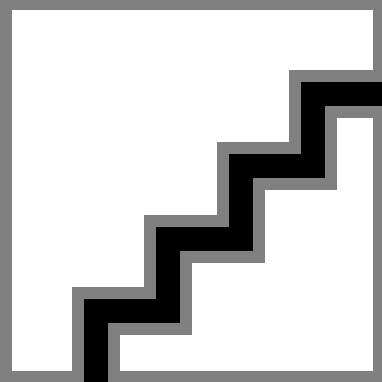
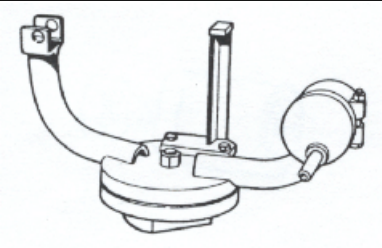
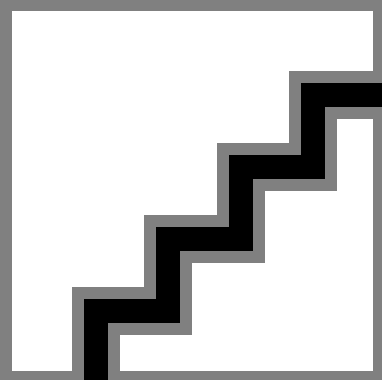

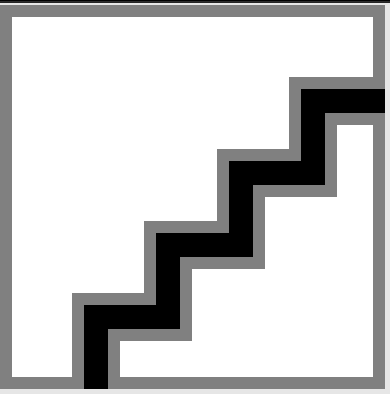

TOOL

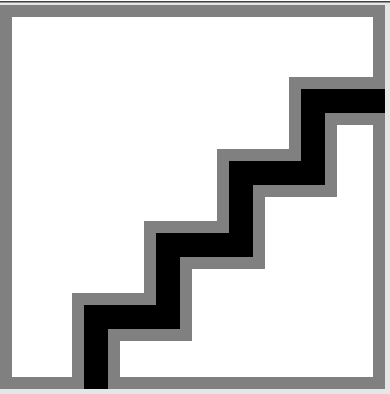
TOOLING



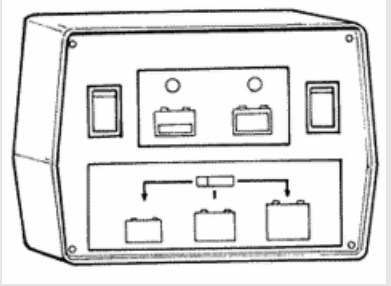

Stores code	Description	
001467Y008	Pliers to extract 17 mm \varnothing bearings	
001467Y029	Bell for bearings, O.D. 38 mm	
004499Y	Bearing extractor. Fitted with: 1 Bell, 2 Sleeve, 3 Screw, 6 Ring, 27 Half rings, 34 Half rings	
005095Y	Engine support	
008119Y009	Tube to assemble shafts and axles	

Stores code	Description	
020004Y	Punch for removing fifth wheels from headstock	
020055Y	Wrench for steering tube ring nut	
020074Y	Tool to align crankshaft	
020150Y	Air heater support	
020151Y	Air heater	
020162Y	Flywheel extractor	
020171Y	Punch for driven pulley roller bearing	



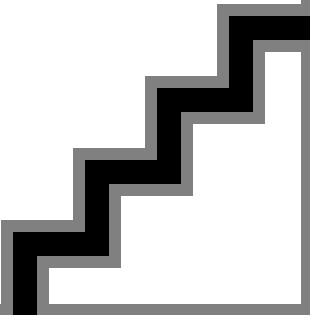

Stores code	Description	
020265Y	Bearing fitting base	
020288Y	Fork to assemble piston on cylinder	
020291Y	Valves assembly/disassembly tool	
020306Y	Punch for assembling valve seal rings	
020329Y	MityVac vacuum-operated pump	

Stores code	Description	
020330Y	Stroboscopic light for timing control	
020331Y	Digital multimeter	
020332Y	Digital rev counter	
020333Y	Single battery charger	
020334Y	Multiple battery charger	

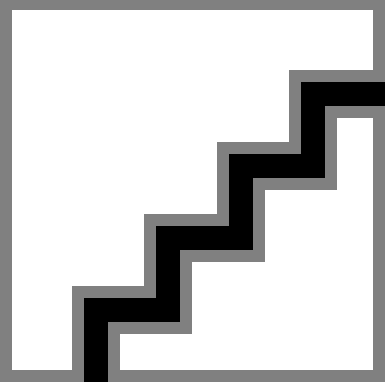
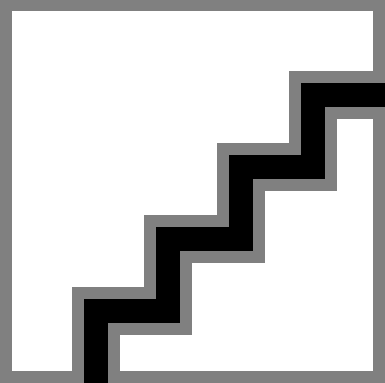
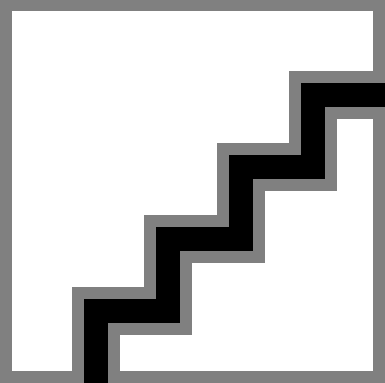
Stores code	Description	
020335Y	Magnetic support for dial gauge	
020340Y	Flywheel and transmission oil seals fitting punch	
020358Y	37x40-mm adaptor	
020359Y	42x47-mm adaptor	
020360Y	Adaptor 52 x 55 mm	
020362Y	12 mm guide	

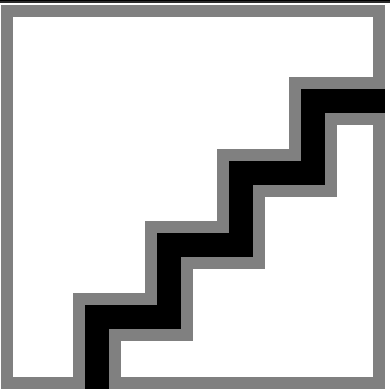
Stores code	Description	
020363Y	20 mm guide	
020364Y	25-mm guide	
020376Y	Adaptor handle	
020431Y	Valve oil seal extractor	
020432Y	Tool to fit the start-up sector spring	

Stores code	Description	
020439Y	17 mm guide	
020444Y	Test probe removal / fitting tool	
020448Y	Pin lock fitting tool	
020449Y	Piston position check support	
020450Y	Camshaft fitting/removal tool	
020451Y	Drive pulley stop wrench	

Stores code	Description	
020452Y	Tube for removing and refitting the driven pulley shaft	
020456Y	Ø 24 mm adaptor	
020565Y	Flywheel lock calliper spanner	
494929Y	Exhaust fumes analyser	

INDEX OF TOPICS

MAINTENANCE

MAIN

Maintenance chart

AFTER 1,000 KM OR 4 MONTHS

90'

Action

Hub oil - change
Valve clearance - check
Idle speed (*) - adjustment
Throttle lever - adjustment
Steering - adjustment
Brake control levers - greasing
Brake pads - check condition and wear
Brake fluid level - check
Safety locks - check
Electrical system and battery - check
Tyre pressure - check
Vehicle and brake test - road test

(*) See instructions in «Idle speed adjustment» section

AT 6000 KM OR 12 MONTHS, 18000, 30000, 42000, 54000 AND 66000 KM

60'

Action

Engine oil - replacement
Hub oil level - check
Spark plug / electrode gap - check
Oil filter (net filter) - clean
Variable speed rollers - check or replacement
Brake pads - check condition and wear
Brake fluid level - check
Electrical system and battery - check
Tyre inflation and wear - Check
Vehicle and brake test - road test

EVERY 12000 OR 24 MONTHS AND AT 60000 KM

Action

Engine oil - replacement
Hub oil level - check
Spark plug / electrode gap - check / replacement
Air filter - clean
Oil filter (net filter) - clean
Idle speed (*) - adjustment
Throttle lever - adjustment
Variable speed rollers - check or replacement
Driving belt - replacement
Odometer cable - greasing
Steering - adjustment
Brake control levers - greasing
Brake pads - check condition and wear
Brake fluid level - check
Transmission elements - lubrication
Emergency blockings (°) - Check
Suspensions - check

Action

Electrical system and battery - check

Headlight - adjustment

Tyres condition and wear - Check

Tyre pressure - check

Vehicle and brake test - road test

(*) Refer to rules (Check to CO)

(°) Refer to predelivery operations

EVERY 24000 KM OR 48000 KM**Action**

Engine oil - replacement

Hub oil level - check

Spark plug / electrode gap - check / replacement

Air filter - clean

Oil filter (net filter) - clean

Valve clearance - check

Idle speed (*) - adjustment

Throttle lever - adjustment

Variable speed rollers - check or replacement

Driving belt - replacement

Cylinder ventilation system - check

Odometer cable - greasing

Steering - adjustment

Brake control levers - greasing

Brake pads - check condition and wear

Brake fluid level - check

Transmission elements - lubrication

Emergency blockings (°) - Check

Suspensions - check

Electrical system and battery - check

Headlight - adjustment

Tyres condition and wear - Check

Tyre pressure - check

Vehicle and brake test - road test

(*)Refer to rules (Check to CO)

(°) Refer to predelivery operations.

EVERY 36000**Action**

Engine oil - replacement

Hub oil level - check

Spark plug / electrode gap - check / replacement

Air filter - clean

Oil filter (net filter) - clean

Idle speed (*) - adjustment

Throttle lever - adjustment

Variable speed rollers - check or replacement

Driving belt - replacement

Odometer cable - greasing

Steering - adjustment

Brake control levers - greasing

Brake pads - check condition and wear

Brake fluid hoses - replacement

Action

Brake fluid level - check
 Transmission elements - lubrication
 Emergency blockings (°) - Check
 Suspensions - check
 Electrical system and battery - check
 Headlight - adjustment
 Tyres condition and wear - Check
 Tyre pressure - check
 Vehicle and brake test - road test

(*)Refer to rules (Check to CO)

(°) Refer to predelivery operations.

EVERY 72000**Action**

Engine oil - replacement
 Hub oil level - check
 Spark plug / electrode gap - check / replacement
 Air filter - clean
 Oil filter (net filter) - clean
 Valve clearance - check
 Idle speed (*) - adjustment
 Throttle lever - adjustment
 Variable speed rollers - check or replacement
 Driving belt - replacement
 Cylinder ventilation system - check
 Odometer cable - greasing
 Steering - adjustment
 Brake control levers - greasing
 Brake pads - check condition and wear
 Brake fluid hoses - replacement
 Brake fluid level - check
 Transmission elements - lubrication
 Emergency blockings (°) - Check
 Suspensions - check
 Electrical system and battery - check
 Headlight - adjustment
 Tyres condition and wear - Check
 Tyre pressure - check
 Vehicle and brake test - road test

(*)Refer to rules (Check to CO)

(°) Refer to predelivery operations.

EVERY 2 YEARS**Action**

Brake fluid - change

EVERY 3,000 KM

10'

Action

Engine oil - level check/ top-up

Carburettor

- Disassemble the carburettor in its parts, wash all of them with solvent, dry all body grooves with compressed air to ensure adequate cleaning.
- Check carefully that the parts are in good condition.
- The **throttle valve** should move freely in the chamber. Replace valve in case of wear due to excessive clearance.
- If there are wear marks in the chamber causing inadequate tightness or a free valve slide (even if it is new), replace the carburettor.
- It is advisable to replace the gaskets at every refit.

WARNING

PETROL IS HIGHLY EXPLOSIVE ALWAYS REPLACE THE GASKETS TO AVOID PETROL LEAKS

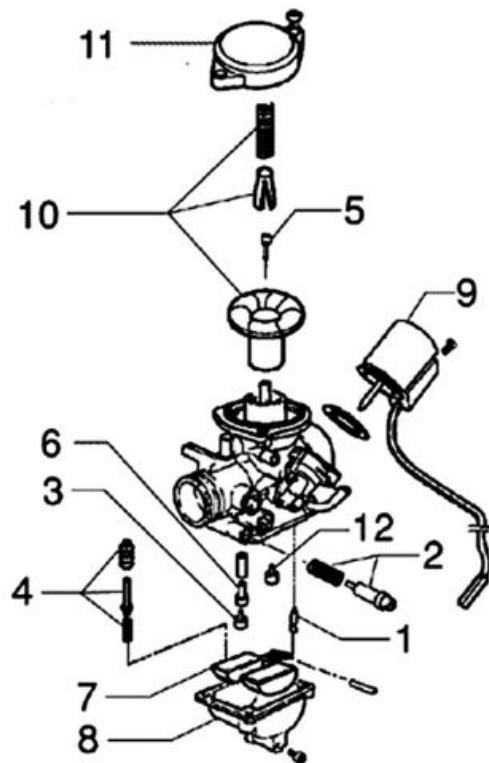

1. Needle valve - 2. Idle speed adjustment screw - 3. Max jet - 4. Accelerating pump - 5. Tapered pin - 6. Jet holder - 7. Float - 8. Tank - 9. Starter device - 10. Vacuum valve - 11. Cover - 12. Minimum jet.

Checking the spark advance

The vehicle is provided with a variable spark advance electronic device. Two reference marks for the timing can be found on the flywheel cover as to find out with more precision the reference mark on the fan. To check, use a stroboscopic gun Tecnotest 130/P or similar type. Start the engine and let it run at 1900 revs/min, act on the phase shifter to align the reference mark on the flywheel fan in between the two reference marks on the casing; at the same time, read the spark advance value on the stroboscopic gun display. The value should be 10°.

Repeat the above operation with engine running at 5000-6000 revs/min, spark advance should be 26°.

CAUTION

SHOULD THE FLASH INDICATIONS BE UNSTABLE AND THE RPM INDICATION DOES NOT CORRESPOND WITH THE TRUE ENGINE SPEED VARIATION (FOR EXAMPLE, VALUES SHOWN ARE HALVED), INSTALL A 10 ÷ 15 KΩ RESISTIVE CABLE CONNECTED IN SERIES TO AN HV CABLE. IF THE IRREGULAR READING CONTINUES AFTER THIS OPERATION, CHECK THE COMPONENTS OF THE IGNITION SYSTEM.

N.B.

WHEN THE INDUCTION CLAMP READS THE SIGNAL CORRECTLY, A READING CAN BE CARRIED OUT AT OVER 6000 RPM.

RPM LIMITER

Specification	Desc./Quantity
1 spark out of 7	8200 Revs/min
1 spark out of 3	8300 Revs/min
Suppression of all sparks	8500 Revs/min

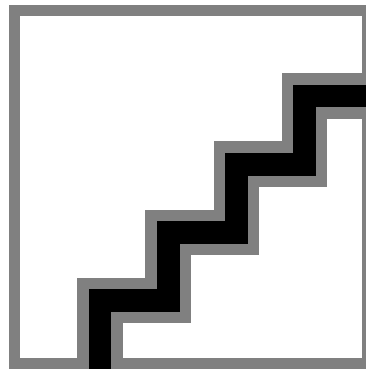
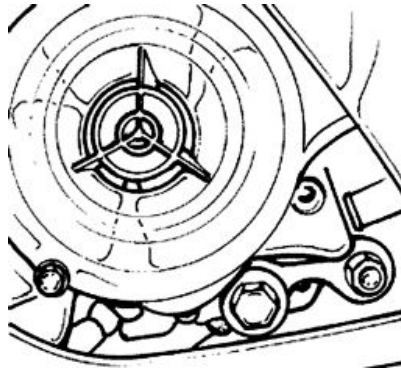
**Spark plug**

The central electrode of the above spark plug is treated with silicone oil that acts as an antioxidant agent. If the silicone oil is in excess, crystals tend to form and, by causing hot fire points to preignition phenomena, tend to reduce the spark plug performance. This results in difficulties for vehicles to reach the maximum speed and anomalous noises.

If the above situation should occur, replace the spark plug before performing any other intervention.

Before installing the new spark plug, blow with air to remove the silicone oil in excess.

Direct the jet of compressed air into the round groove between the threaded metal part and the ceramic part of the inner electrode while turning the spark plug to allow removal of the oil in excess.

Detach the spark plug cap and then remove the spark plug.

- Carefully examine the spark plug, and replace it if the insulator is damaged or chipped.
- With the aid of a feeler gauge, measure the spark gap and, if necessary, adjust by bending outer electrode with care.
- Ensure the sealing washer is in good conditions.
- Refit the spark plug by engaging the thread manually and then tightening it to the prescribed torque using the box-spanner provided.

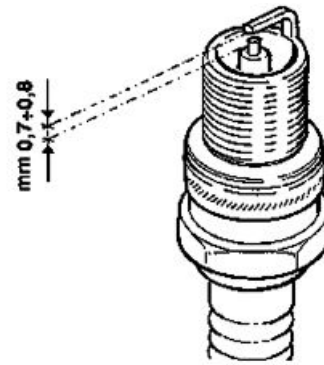

Characteristic

Electrode gap

0.7 ÷ 0.8 mm

Spark plug

NGK CR 8EB

Locking torques (N*m)

Spark plug 10 ÷ 15 Nm

Hub oil

Check

- Place the vehicle on the stand on level ground.
- Unscrew oil dipstick «A», wipe it with a clean rag, reinsert it and **screw it in fully**.
- Pull out the dipstick and check that the oil level is in the middle (two-notch dipstick) or reaches the middle notch (three-notch dipstick).
- Reinsert the dipstick and screw it in fully.

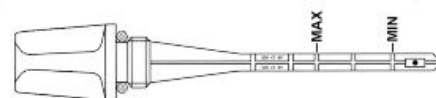
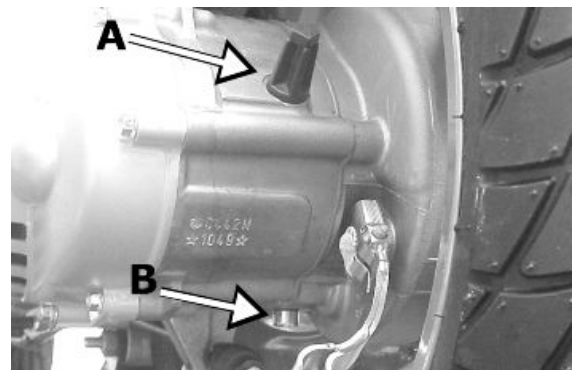

Recommended products

AGIP ROTRA 80W-90 rear oil hub

SAE 80W/90 Oil that exceeds the requirements of API GL3 specifications

Replacement

- Remove oil filler cap/dipstick «A».
- Unscrew the drain plug «B» shown in the figure and allow the oil to drain out.
- Retighten the drain plug and fill the hub with oil (about 100 cc).

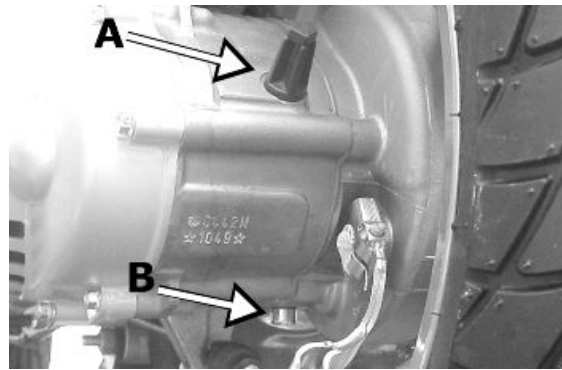

Air filter

After removing the lower part of the left-hand side cover, unscrew the four fixing screws and the two knobs (which are exposed by overturning the saddle and removing the helmet compartment), remove the filter cover and then pull out the filter cartridge.

Cleaning:

- Wash the filter with soap and water.
- Dry with a clean cloth without wringing and with compressed air.
- Soak with a 50% fuel-oil mixture.
- Let the filter cartridge drip and then squeeze it between the hands without wringing.

CAUTION

NEVER RUN THE ENGINE WITHOUT THE AIR FILTER, THIS WOULD RESULT IN AN EXCESSIVE WEAR OF THE PISTON AND CYLINDER.

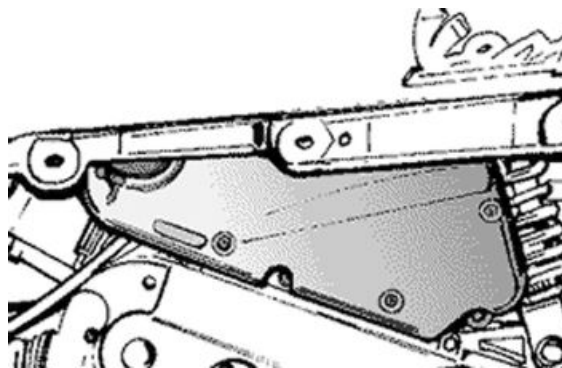

Engine oil

Replacement

- Loosen the oil filler plug.
- Unscrew the gauze strainer drain plug on the fly-wheel side and allow the oil to drain completely.
- Retighten the drain plug and pour in approximately 600-650 cc of oil.

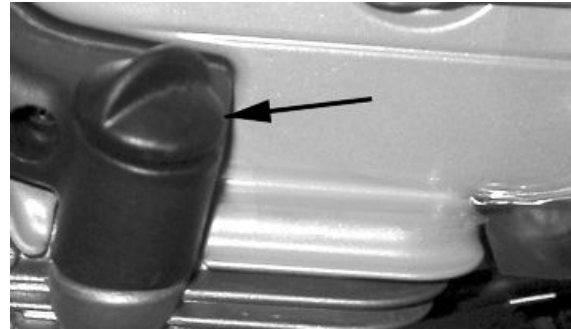

Check

- Rest the vehicle (with the engine cold) on its centre stand on flat ground.
- Ensure the oil level is between the MAX and MIN marks on the dipstick.
 - The MAX mark implies a quantity of ~ 850 cc of oil in the engine.
 - If the oil level approaches the MIN mark, top up with fresh oil without ever exceeding the MAX mark.

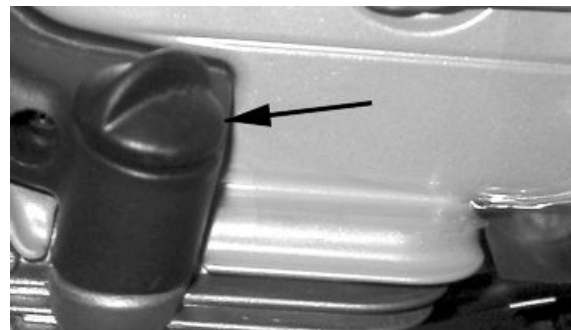

Recommended products

AGIP CITY HI TEC 4T Oil to lubricate flexible transmissions (brakes, throttle control and odometer)

Oil for 4-stroke engines



Engine oil filter

- Change the oil when the engine is warm.
- Place a container under the oil sump and remove the cap for draining the oil.
- After draining the oil clean the mesh filter with a specific solvent and then blow it down with compressed air.
- The latter is accessible by removing the cap «A» (see figure).

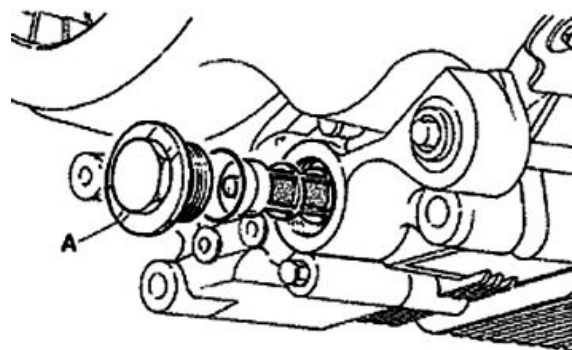

- After this operation refit the filter and tighten the oil cap to the sump using a new O-ring.
- Fill the engine oil through the hole located on the oil sump.
- Engine oil capacity: ~ 850 cc.
- Manually tighten cap.

N.B.

RUN THE ENGINE FOR A FEW MINUTES THEN RECHECK THE ENGINE OIL LEVEL WHEN THE ENGINE IS COLD, IT MUST ALWAYS REMAIN UNDER THE MAX LEVEL.

N.B.

IF FILLING FOR THE 1ST TIME OR FOR OVERHAUL ADD 850 C.C. OF ENGINE OIL, IN OTHER CASES 650 C.C. AND FILL UP IF NECESSARY.

Recommended products

AGIP CITY HI TEC 4T Engine oil

SAE 5W-40 Synthetic oil that exceed the requirements of API SL, ACEA A3, JASO MA specifications

Locking torques (N*m)

Engine oil pre-filter cover 25 ÷ 28 Nm

Checking the ignition timing

- Turn the flywheel clockwise until its 2nd notch coincides with the Pick-up reference mark as shown in the figure.

Make sure that the reference point on the camshaft command crown is aligned with the reference point on the head as shown in the second figure.

If the reference is opposite the indicator on the head, turn the crankshaft once more as the piston must be at the TDC of the bursting phase.

N.B.

TIME THE TIMING SYSTEM UNIT AS DESCRIBED IN CHAPTER 6 IF IT IS NOT IN PHASE

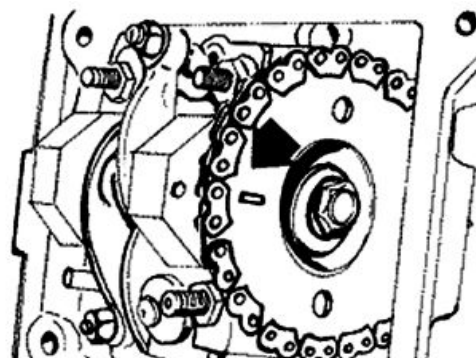
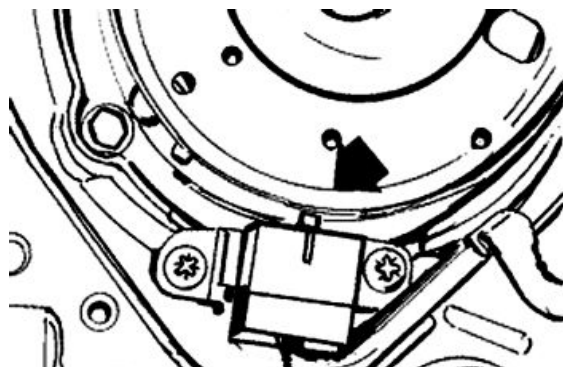

Checking the valve clearance

- Remove the spark plug access cover, undo the 4 fixing screws indicated in the figure and remove the tappet cover.

- To check valve clearance, centre the reference marks of the timing system point as described above.

- Use an adequate thickness gauge to check that the clearance between the valve and the register corresponds with the indicated values.

Should the valve clearance values, intake and drainage respectively, be different from the ones indicated below, adjust them by loosening the lock nut and operate on the register with a screwdriver as shown in the figure.

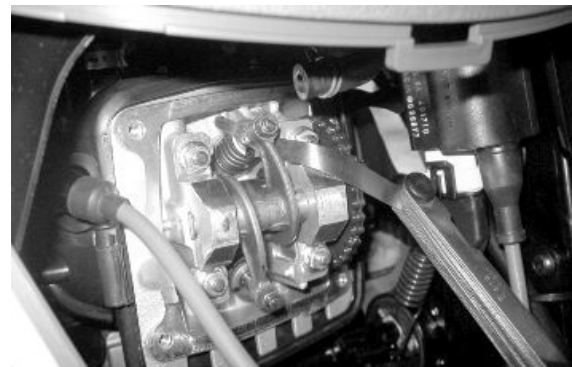
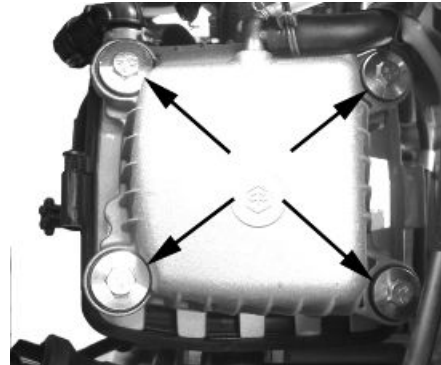

Characteristic

Intake (with cold engine)

0.10 mm

Drainage (with cold engine)

0.15 mm

Headlight adjustment

Proceed as follows:

1. Place the vehicle in running order and with the tyres inflated to the prescribed pressure, on a flat surface 10 m away from a white screen situated in a shaded area, making sure that the longitudinal axis of the scooter is perpendicular to the screen;
2. Turn on the headlight and check that the borderline of the projected light beam on the screen is not lower than 9/10 of the distance from the ground to the centre of vehicle headlamp and higher than 7/10;
3. If otherwise, adjust the right headlight with screw «A».

N.B.

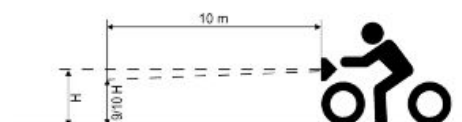
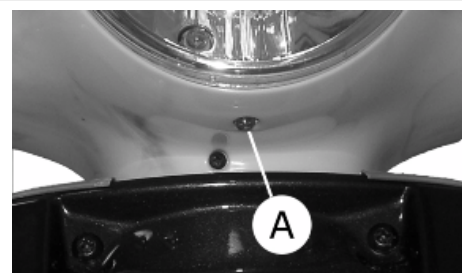

THE ABOVE PROCEDURE COMPLIES WITH THE EUROPEAN STANDARDS REGARDING MAXIMUM AND MINIMUM HEIGHT OF LIGHT BEAMS. REFER TO THE STATUTORY REGULATIONS IN FORCE IN EVERY COUNTRY WHERE THE vehicle IS USED.

SAS filters inspection and cleaning

Use the two screws "A" on the right side panel and remove it. Use the three screws "B" to remove the cover of the secondary air box. Move the cover of the box away and remove the sponge filter "C". Wash the sponge with water and a neutral soap, and dry it with a clean rag and shorts blasts of compressed air. When cleaning the filter, make sure the reed valve "D" is in good condition then reinsert it in its seat on the box.

Before closing the SAS box cover, check the condition of the O-ring seal; replace it if it appears damaged or deformed.

N.B.

The reed valve can be inserted in only one direction on the SAS housing

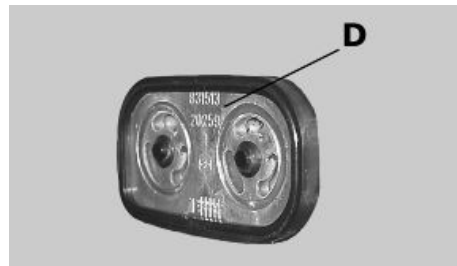
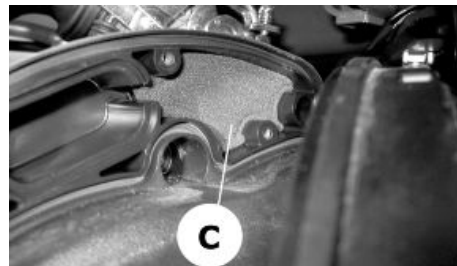
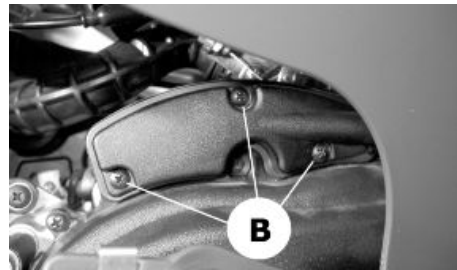

INDEX OF TOPICS

TROUBLESHOOTING

TROUBL

Engine

Poor performance

POOR PERFORMANCE

Possible Cause	Operation
Air filter clogged or dirty	Disassemble, wash sponge with water and shampoo and immerse in a mixture of 50% petrol and Selenia Air Filter oil. Let it drip. Wring out without squeezing it and then refit
Carburettor nozzles clogged or dirty	Dismantle, wash with solvent and dry with compressed air
Dirty or faulty vacuum-operated cock	Check the filter on the cock, remove the petrol and wash the tank, if necessary. Replace the cock as a last resource.
Clutch slipping	Check the clutch system and/or the bell and replace if necessary
Inefficient automatic transmission	Check the rollers and the pulley movement, replace the damaged parts and lubricate the driven pulley moveable guide with Montblanc Molybdenum Grease
Lack of compression parts, cylinder and valves wear	Replace the worn parts
Oil level exceeds maximum	Check for causes and fill to reach the correct level
Excess of encrustations in the combustion chamber	Descale the cylinder, the piston, the head and the valves
Timing failure or timing system parts worn	Reset timing phase or replace any worn parts (refer to 4-stroke 50 cc engine manual)
Muffler obstructed	Replace
Fuel filter on vacuum operated cock blocked	Clean the cock filter
Wrong valve adjustment	Adjust the valve clearance properly
Valve seat distorted	Replace the head assembly
Worn cylinder, Worn or broken piston rings	Replace the piston cylinder assembly or just the piston rings

Rear wheel spins at idle

REAR WHEEL

Possible Cause	Operation
Idling rpms too high	Check the idling speed and, if necessary, adjust the C.O.
Clutch fault	Check the spring/friction mass and the clutch bell
Air filter housing not sealed	Correctly refit the filter housing and replace it if it is damaged
Purifier-carburettor fitting damaged	Replace

Starting difficulties

STARTING PROBLEMS

Possible Cause	Operation
Defective spark plug or with incorrect electrode gap	Check and if necessary replace the spark plug and the electrode gap
Battery flat	Check the state of the battery. If it shows signs of sulphation replace it and bring the new battery into service charging it for eight hours at a current of 1/10 of the capacity of the battery itself
- Engine flooded.	Start up keeping the throttle fully open alternating approximately five seconds of turning it with five seconds still. If however it does not start, remove the spark plug, the engine over with the throttle open being careful to keep the cap in contact with the spark plug and the spark plug grounded but away from its hole. Refit a dry spark plug and start the vehicle.
Vacuum operated cock failure	Check that fuel is adequately supplied through the pipe by applying a vacuum to the suction pipe
Failing automatic starter on the carburettor	Check the electrical wiring and mechanical movement, replace if necessary.
Wrong ignition advance	Check flywheel keying on the crankshaft, replace control unit if necessary
Incorrect valve sealing or valve adjustment	Inspect the head and/or restore the correct clearance
Starting rpm too low. Starter motor faulty.	Check starting motor.
Altered fuel characteristics	Drain off the fuel no longer up to standard; then, refill
Carburettor nozzles clogged or dirty	Dismantle, wash with solvent and dry with compressed air

Engine tends to cut-off at full throttle

ENGINE TENDS TO CUT OUT AT FULL THROTTLE

Possible Cause	Operation
Maximum jet clogged	Remove the carburettor, wash with solvent and dry with compressed air
Water or condensate in the carburettor tank	Remove the tank, wash with solvent and dry with compressed air or empty the tank through the appropriate bleed screw
Incorrect ignition advance	Use a stroboscopic light to check ignition advance and the flywheel correct keying
Air filter blocked or dirty.	Dismantle the sponge, wash with water and shampoo, then soak it in a mixture of 50% petrol and 50% of specific oil (Selenia Air Filter Oil), then hand dry without squeezing, allow to drip dry and then reassemble.
Incorrect float level	Restore the correct level in the tank (the float must be parallel to the upper cover contact plane, that is the throttle valve membrane cover)
Fuel supply pipes choked or clogged	Restore the adequate fuel supply
Tank breather hole obstructed	Restore the proper tank aeration

Possible Cause

Operation

Level in tank too low

Restore the correct level in the tank (the float must be parallel to the upper cover contact plane, that is the throttle valve membrane cover)

Engine tends to cut-off at idle

ENGINE TENDS TO STOP WHEN IDLING

Possible Cause

Operation

Air calibrated holes in carburettor blocked

Dismantle, wash with solvent and dry with compressed air

Defective floating valve

Check the proper sliding of the float and the functioning of the valve

Level in tank too high

Restore the correct level in the tank (the float must be parallel to the upper cover contact plane, that is the throttle valve membrane cover)

Automatic choke stays activated

Check that the piston slides freely and that fuel is supplied to the automatic choke. Renew if necessary

Air filter blocked or dirty.

Dismantle the sponge, wash with water and shampoo, then soak it in a mixture of 50% petrol and 50% of specific oil (Selenia Air Filter Oil), then hand dry without squeezing, allow to drip dry and then reassemble.

Wrong idling adjustment

Correctly adjust the engine idling and check the level of the C.O.

Spark plug defective or faulty

Replace the spark plug with one with the specified degree and check the plug gap

Pressure too low at the end of compression

Check the thermal group seals and replace worn components

Incorrect timing

Time the system and check the timing system components

High fuel consumption

EXCESSIVE FUEL CONSUMPTION

Possible Cause

Operation

Air filter blocked or dirty.

Dismantle the sponge, wash with water and shampoo, then soak it in a mixture of 50% petrol and 50% of specific oil (Selenia Air Filter Oil), then hand dry without squeezing, allow to drip dry and then reassemble.

The starter remains on

Check that the starter runs correctly and it is properly powered

Loose nozzles

Check the maximum and minimum nozzles are adequately fixed in their fittings

Incorrect float level

Check and restore the correct fuel level in the tank

Transmission and brakes

Clutch grabbing or performing inadequately

IRREGULAR CLUTCH PERFORMANCE OR SLIPPAGE

Possible Cause	Operation
Faulty clutch	Check that there is no grease on the masses. Check that the clutch mass contact surface with the casing is mainly in the centre with equivalent characteristics on the three masses. Check that the clutch casing is not scored or worn in an anomalous way

Insufficient braking

INEFFICIENT BRAKING

Possible Cause	Operation
Worn brake pads or shoes	Replace the brake pads or shoes and check for brake disk or drum wear conditions.
Air bubbles inside the hydraulic braking system	Carefully bleed the hydraulic braking system, (there must be no flexible movement of the brake lever).
Brake disc or drum deformed	Use a dial gauge to check the levelness of the disk with the wheel correctly fitted and the concentricity of the rear drum; check the brake disc screws are locked
Fluid leakage in hydraulic braking system	Elastic fittings, piston seals or brake pump breakdown, replace
Excessive backlash in rear brake control cable	Adjust backlash with the appropriate adjuster on the shoe control lever
The brake fluid has lost its properties	Replace the front brake fluid and top up to the correct level in the pump
Return spring broken	Replace spring.
Shoe control bolt not lubricated	Lubricate with Z2 grease.

Brakes overheating

BRAKES OVERHEATING

Possible Cause	Operation
Defective sliding of pistons	Check calliper and replace any damaged part.
Brake disc or drum deformed	Use a dial gauge to check the levelness of the disk with the wheel correctly fitted and the concentricity of the rear drum; check the brake disc screws are locked

Electrical system

Battery

BATTERY

Possible Cause	Operation
This device requires the most assiduous surveillance and the most diligent maintenance.	This device requires the most assiduous surveillance and the most diligent maintenance. If the vehicle is not used for some time (1 month or more) the battery needs to be recharged periodically. The battery tends to exhaust its power supply in five to six months. If the battery is fitted on a motorcycle, be careful not to invert the connections, keeping in mind that the black earth wire is connected to the negative terminal while the red wire is connected to the terminal marked +.

Turn signal lights malfunction

ELECTRICAL EQUIPMENT FAILURE

Possible Cause	Operation
Turn indicators do not turn on	Check turn indicators device and/or wiring as described in the «Electrical system» chapter.

Steering and suspensions

Heavy steering

STEERING HARDENING

Possible Cause	Operation
Steering hardening	Check the tightening of the top and bottom ring nuts. If irregularities continue in turning the steering even after making the above adjustments, check the seats in which the ball bearings rotate: if they are recessed or if the balls are squashed, replace them.

Excessive steering play

EXCESSIVE STEERING CLEARANCE

Possible Cause	Operation
Excessive steering backlash	Check the tightening of the top ring nut. If irregularities continue in turning the steering even after making the above adjustments, check the seats in which the ball bearings rotate: replace if they are recessed.

Noisy suspension**SUSPENSION NOISY**

Possible Cause	Operation
Noisy suspension	<p>If the front suspension is noisy, check: that the front shock absorber works properly and the ball bearings are good condition.</p> <p>In conclusion, check the tightening torque of the wheel hub, the brake calliper, the shock absorber disk in the attachment to the hub and the steering tube.</p> <p>Check that the swinging arm connecting the engine to the chassis and the rear shock absorber work properly</p>

Suspension oil leakage**OIL LEAKAGE FROM SUSPENSION**

Possible Cause	Operation
Oil leakage from suspension	Replace the damper.

INDEX OF TOPICS

ELECTRICAL SYSTEM

ELE SYS

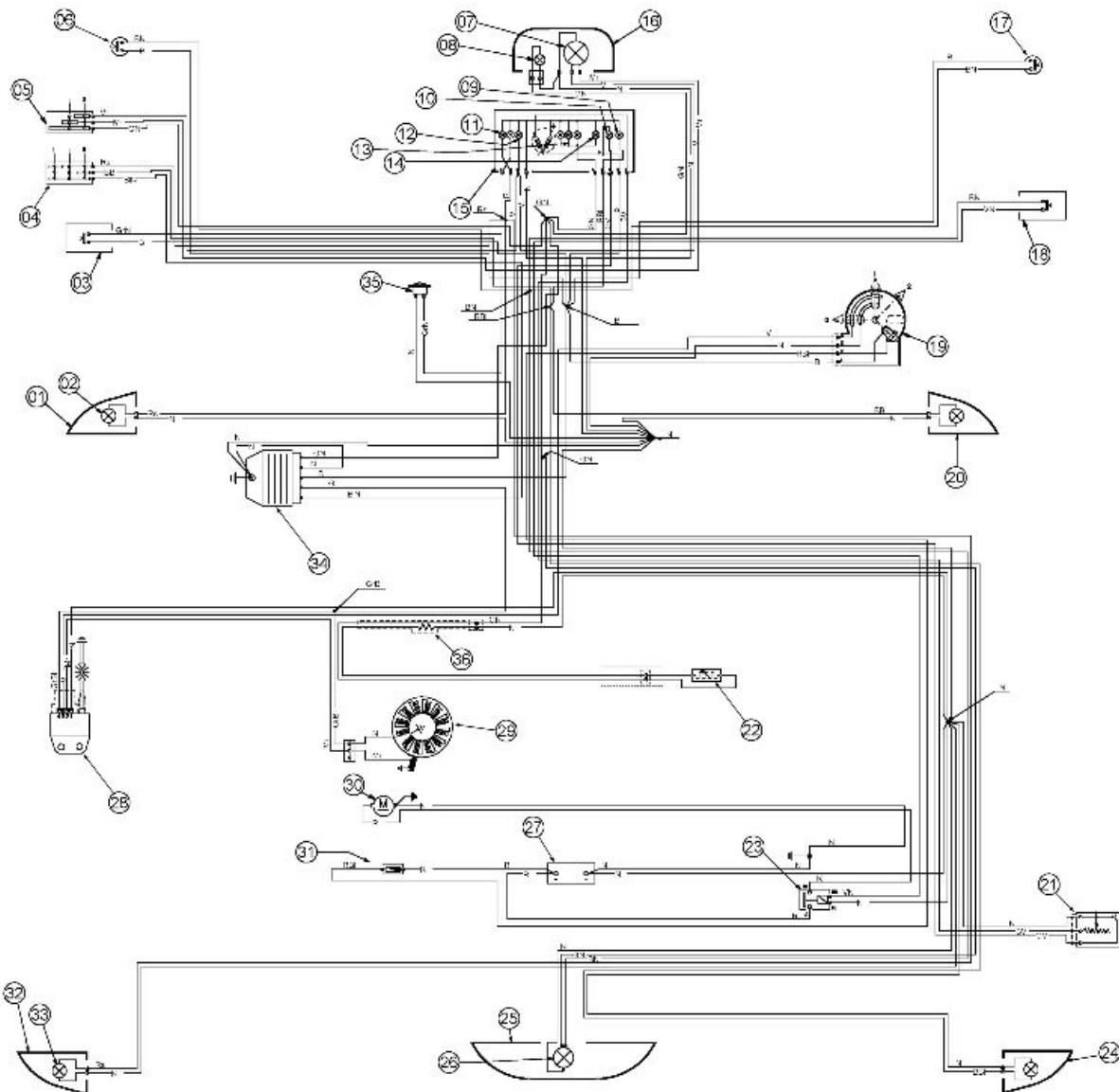

ELECTRICAL COMPONENTS

	Specification	Desc./Quantity
1	Front L.H. turn signal light	
2	Front direction indicator lights	12V-10W x 2
3	Horn button	
4	Indicators switch	
5	Light switch	
6	Rear stop switch	
7	Headlight bulb	12V-35/35W
8	Front tail light bulb	Type: All glass Power: 12V 5W Quantity: 1
9	Right turn indicator warning light	12V-2W
10	Reserve fuel light	12V-1,2W
11	left turn indicator warning light	12V-2W
12	High beam warning light bulb	12V-1,2W
13	Dashboard light bulbs	Type: Bayonet Power: 12V 1.2W

Specification		Desc./Quantity
		Quantity: 3
14	Headlamp warning light	12V 1,2W
15	Odometer with warning lights and level gauges	
16	Front headlight	
17	Front brake stop light switch	
18	Starter button	
19	Ignition key-switch	
20	Front R.H. turn signal light	
21	Fuel level sender	
22	Automatic starter	
23	Starter remote control	
24	Rear R.H. turn signal light	
25	Taillight assembly	
26	Stop and tail light bulb	Type: Spherical Power: 12V 21/5W Quantity: 1
27	Battery	12V - 9Ah
28	Control device ignition	
29	Flywheel magneto	
30	Starter motor	
31	Fuse carrier	(N° 1 fuse to 10 A)
32	Rear L.H. turn signal light	
33	Rear direction indicator lights	N° 2, 12V-10W, spherical
34	Voltage regulator	
35	Claxon in c.c.	
36	Resistance	10 Ohm - 10W

Electrical cables color:

B = White, **Bl** = Blu, **G** = Yellow, **Mr** = Brown, **N** = Black, **Gr** = Gray,

Rs = Pink, **R** = Red, **Vi** = Purple, **V** = Green

Conceptual diagrams

Ignition

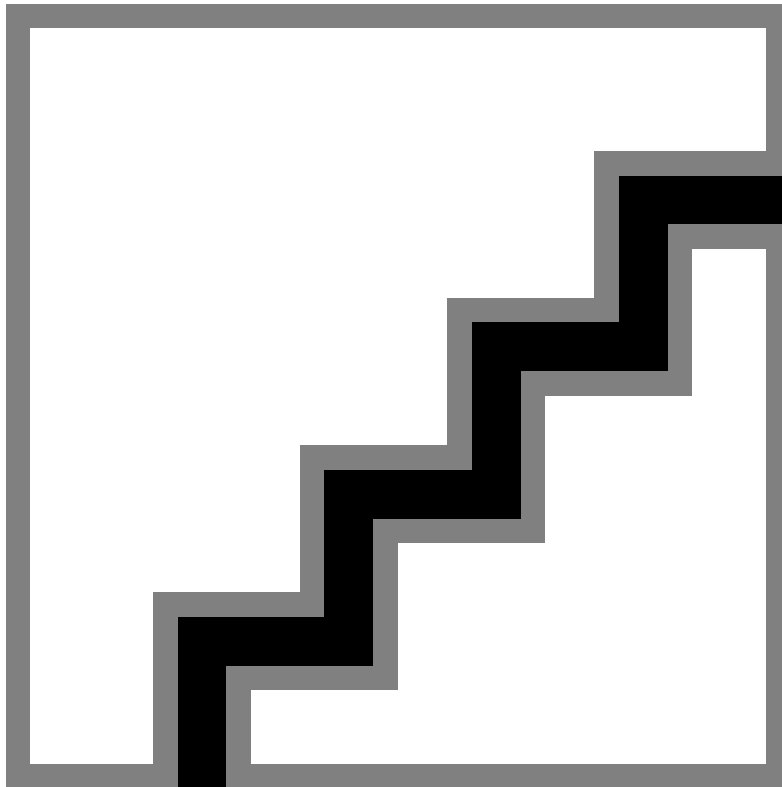

IGNITION

	Specification	Desc./Quantity
1	Magneto flywheel	
2	Pick - up	
3	Key switch contacts	
4	Electronic ignition device	
5	Fuse	10 A
6	Voltage regulator	
7	Battery	12V-9Ah

Headlights and automatic starter section

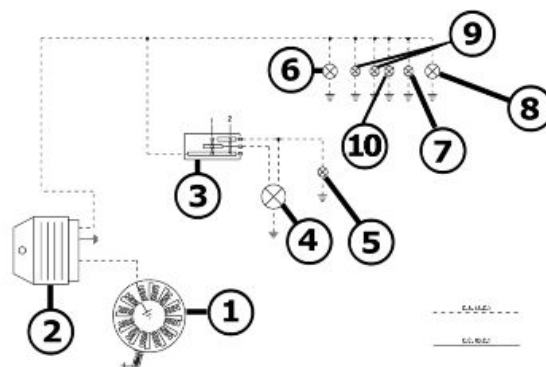

HEADLIGHTS

	Specification	Desc./Quantity
1	Magneto flywheel	
2	Voltage regulator	
3	Light switch	
4	Headlight bulb	12V-35/35W
5	High beam warning light bulb	12V-1,2W
6	Rear light bulb	12V - 5W
7	Headlight warning light	12V - 1.2W
8	Front position light filament	12V - 5W
9	Instrument panel light bulbs	Type: All glass Power: 12V 1.2W Quantity: 2
10	Dashboard light bulbs	12V-2W

Battery recharge and starting

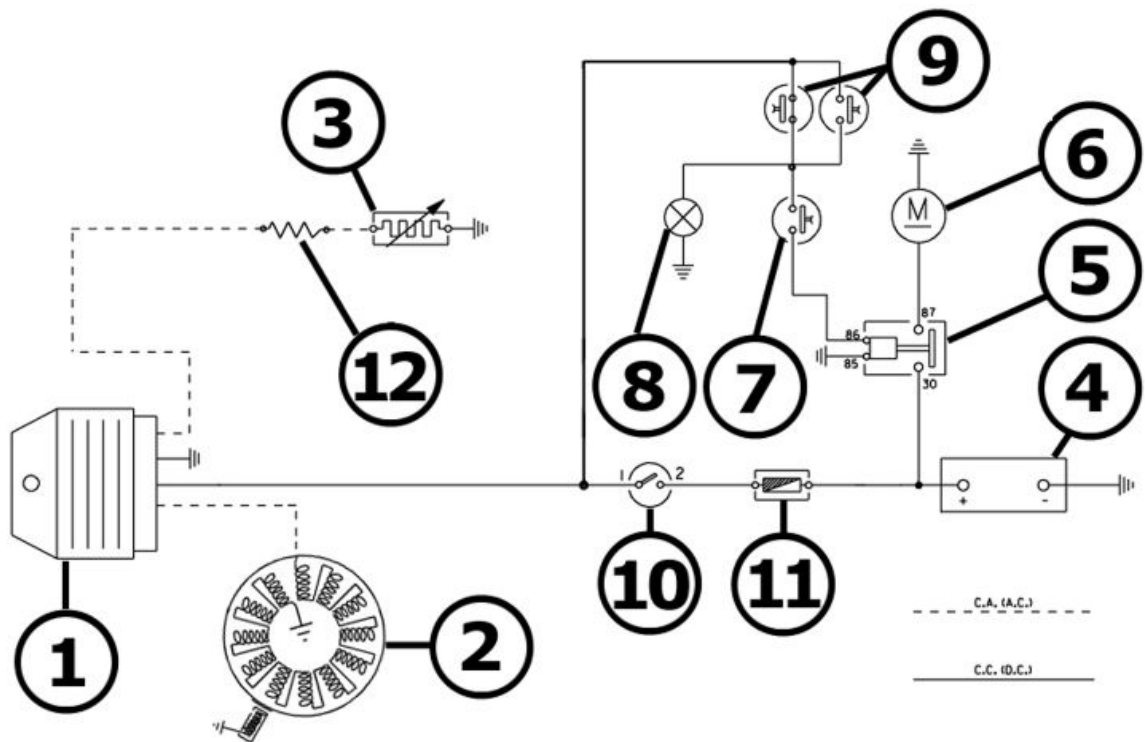

BATTERY RECHARGE AND START-UP SECTION

	Specification	Desc./Quantity
1	Voltage regulator	
2	Magneto flywheel	
3	Automatic starter	
4	Battery	12V-9Ah
5	Remote starter switch	
6	Starter motor	
7	Start up button	
8	Brake light filament	12V-21W
9	Front and rear brake light button	

	Specification	Desc./Quantity
10	Key switch	
11	Main fuse	10A
12	Resistance	6,8 Ohm - 10W

Level indicators and enable signals section

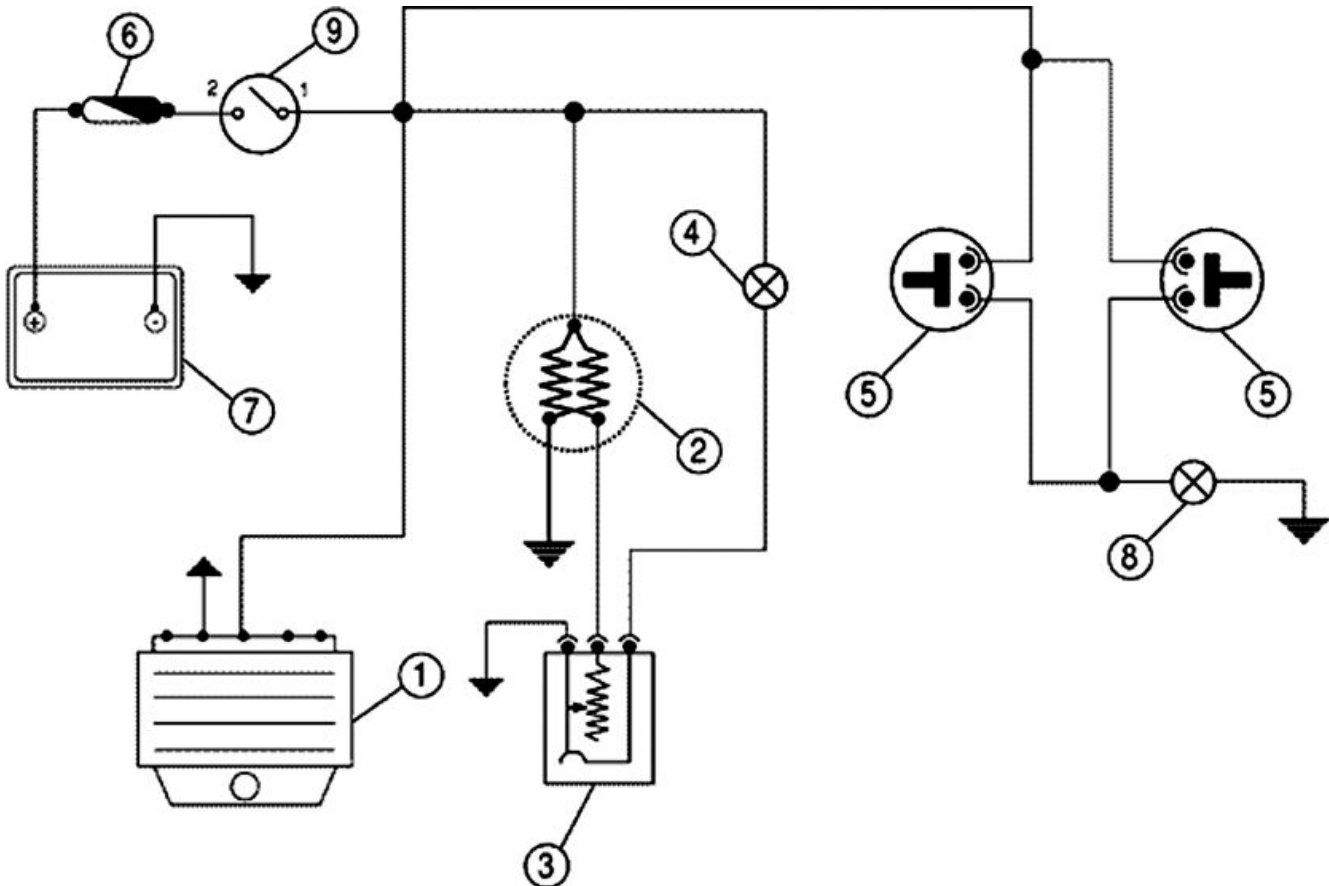

START PERMISSIVE BUTTONS AND LEVEL INDICATORS

	Specification	Desc./Quantity
1	Voltage regulator	
2	Fuel Level indicator	
3	Fuel level sender	
4	Reserve fuel light	12V-1,2W
5	Front and rear brake light button	
6	Fuse	10 A
7	Battery	12V-9Ah
8	Brake light filament	12V-21W
9	Key switch contacts	

Turn signal lights

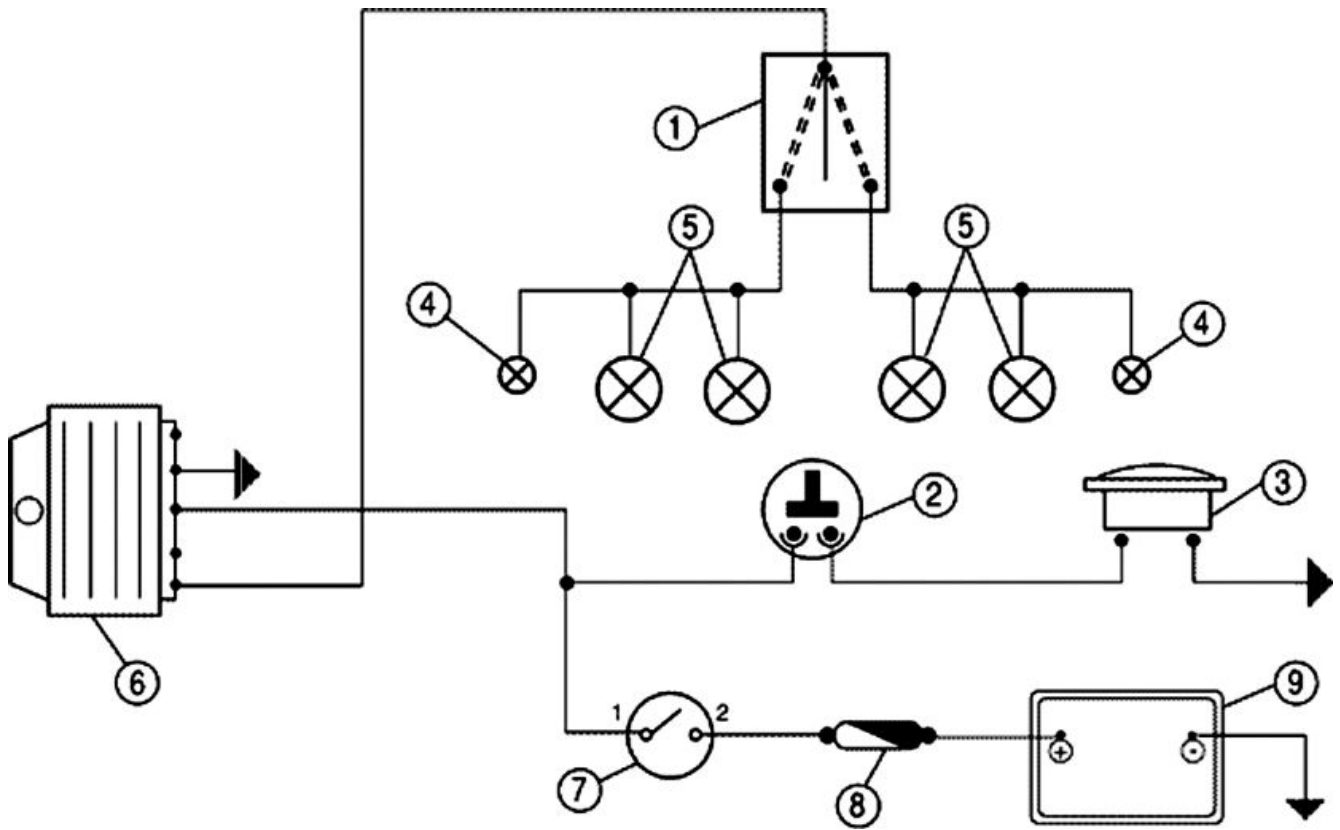

TURN INDICATORS AND HORN

	Specification	Desc./Quantity
1	Indicators switch	
2	Horn button	
3	Horn	
4	Two (2) turn signal warning light bulbs	12V - 2W
5	4 Turn indicator bulbs	12V-10W
6	Voltage regulator	
7	Key switch contacts	
8	Fuse	10 A
9	Battery	12V-9Ah

Instruments and warning lights control board

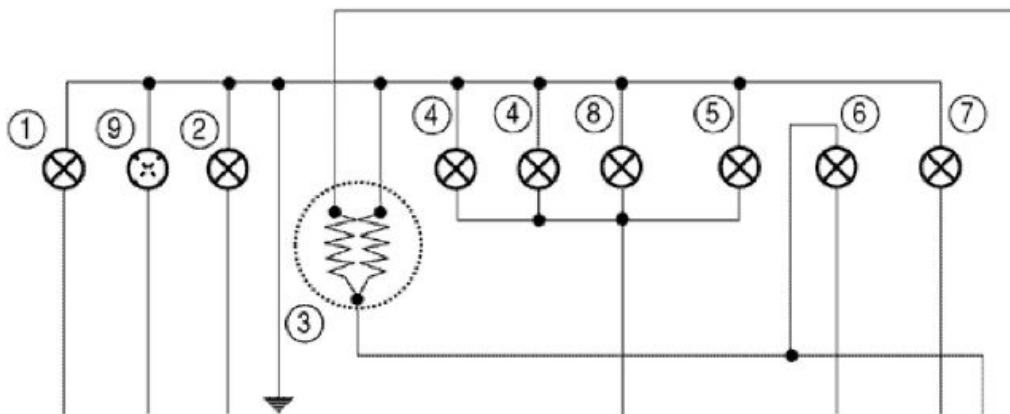

WARNING LIGHTS AND GAUGES PANEL

	Specification	Desc./Quantity
1	left turn indicator warning light	12V-2W
2	High beam warning light bulb	12V-1,2W
3	Fuel Level indicator	
4	Instrument panel lighting bulb	12V-1,2W
5	Headlamp warning light	12V 1,2W
6	Reserve fuel light	12V-1,2W
7	Right turn indicator warning light	12V-2W
8	Dashboard light bulbs	12V-2W
9	Available warning light	

Checks and inspections

In case the cause of ignition failure or malfunction cannot be easily identified at sight, first of all replace the control unit by another one in operating conditions.

Remember that the engine must be off to disconnect and replace the control unit.

If after replacement the vehicle starts properly, the control unit is failing and must be replaced.

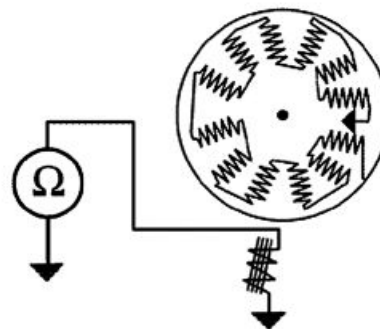

If faulty or failed operation persists, conduct the following checks on the generator and on the stator components:

After a visual inspection of the electrical connections, it is possible to perform measurements on the stator winding and pick-up (see table), using the specific multimeter.

If, during the checks on the charge coil and the pick-up, anomalies are found, replace the stator and other faulty parts.

Disconnect the connector on the flywheel housing and measure the resistance between each of the two contacts and the earth.

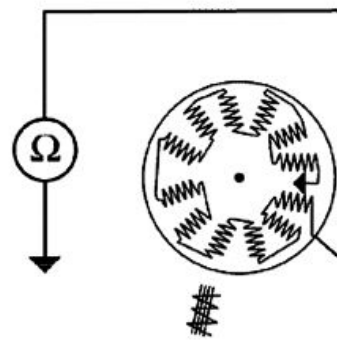

Specific tooling

020331Y Digital multimeter

PICK-UP CHECK

	Specification	Desc./Quantity
1	1) Brown cable and earth	~ 170 Ω

STATOR WINDING CHECK

	Specification	Desc./Quantity
1	1) Black cable and earth	~ 1 Ω

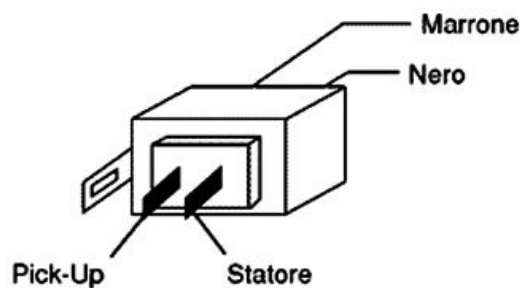

Ignition circuit

All the control operations of the system that require the disconnection of cables (checks of the connections and the devices making up the ignition circuit) must be done with the engine off: if this is not done, the controls might be irreparably damaged.

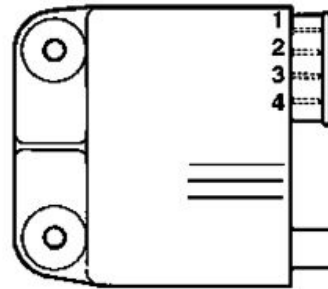

Stator check

- Using a tester, check the resistance between the brown-earth and black-earth terminal.

N.B.

VALUES ARE STATED AT AMBIENT TEMPERATURE. A CHECK WITH THE STATOR AT OPERATING TEMPERATURE LEADS TO VALUES HIGHER THAN THOSE STATED.

Electric characteristic

Stator : Brown-earth

approx. 170 Ω (Pick-Up)

Stator : Black-earth

~ 1 Ω (Stator)

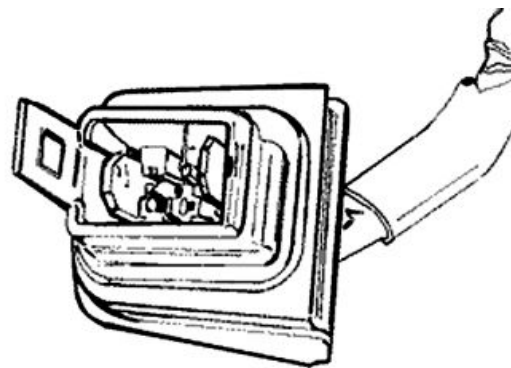

Voltage regulator check

The malfunctioning of the voltage regulator might cause the following problems depending on the type of fault:

- 1) Bulbs burnt out (regulator in short circuit).
- 2) The lighting and electrical starter system do not work (regulator interrupted).
- 3) Battery fails to charge
- 4) Turn indicators failure

The regulator is provided with earth supplied from the electrical equipment, therefore the regulator body does not supply earth to the internal circuits. Check the insulation between each terminal of the regulator and its body, using the specific tester.

2) LIGHTS AND CHOKE DEVICE NOT OPERATIONAL

Remove the plastic door on the leg-shield to reach the voltage regulator, start the engine and let it run at idle.

Place the positive terminal from the tester on terminal no. 1 (yellow-black wire) and the negative terminal on terminal no. 2 (black wire); check for voltage.

If voltage is present, check the wiring connecting the headlight switch to the voltage regulator, and the operation of the light switch.

If no voltage is found, put the negative terminal to earth; if this provides voltage readings, check the earth wire on the regulator; otherwise, replace the regulator as certainly faulty.

As a last test it is possible to check the output voltage from the stator:

-Detach the regulator connector and interpose the tester between the Gray-Blue wire (4) and earth (see figure).

-The voltage output at 2,000 rpm must be approx. 25 - 35V If this test gives no voltage readings too, replace the regulator as certainly faulty.

N.B.

TO MEASURE THE ABOVE VOLTAGE USE AN ANALOGUE TESTER THAT CAN MEASURE ALTERNATING VOLTAGES AND KEEP THE ENGINE AT IDLE TO HAVE AN ALTERNATING VOLTAGE OF A FREQUENCY AS CLOSE AS POSSIBLE TO 50HZ SO AS TO DETECT THE EFFICIENT VOLTAGE VALUE SUPPLIED BY THE REGULATOR (ABOUT 12V).

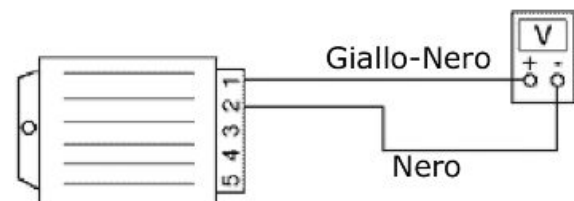
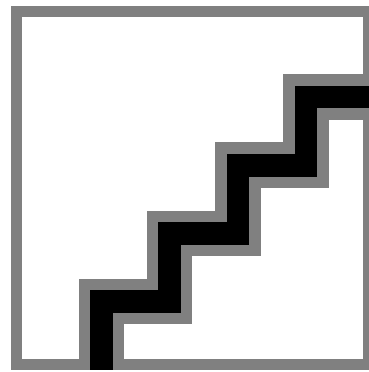

~ 12V a 1900÷2000 giri/min.

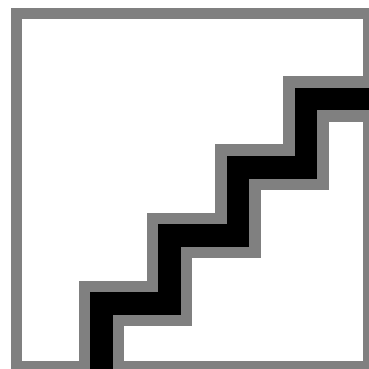
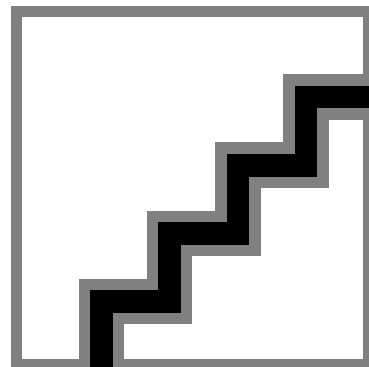

Recharge system voltage check

3) BATTERY DOES NOT RECHARGE

The fault in the DC section of the voltage regulator may cause, depending on the type of failure, the following faults:

a) Bursting of protection fuse due to excessively high voltage (regulator short-circuited) and resulting in the battery not recharging.

b) Battery not recharging (regulator circuit interrupted).

Interventions

a) Bursting of protection fuse (regulator short-circuited).

Check the wiring running from the fuse to the ignition key-switch is not damaged, as this may create a short-circuit with earth (thus excluding possible regulator failures); if the protection fuse bursts only after the ignition key-switch is turned to "ON", and with the regulator connector detached, it is then necessary to check the wirings and systems downstream the key-switch are not short-circuited with earth.

Proceed by measuring the resistance between contacts 3 (White) and 2 (Black) from the voltage regulator (with the connector detached).

If the reading differs excessively from the figures shown, replace the regulator as short-circuited.

b) Battery not recharging (regulator circuit interrupted).

To check for the presence of faults on the recharging section of the voltage regulator, it is necessary to initially operate on the battery, using two testers (one for voltages and one for currents), as shown in the second figure, and follow the operations given below:

Start the engine (connecting, temporarily, the red wire to the positive terminal of the battery, so to

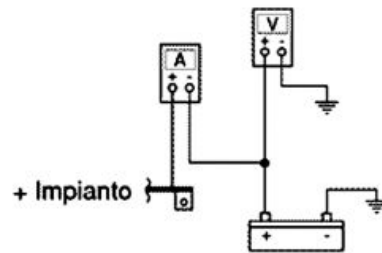
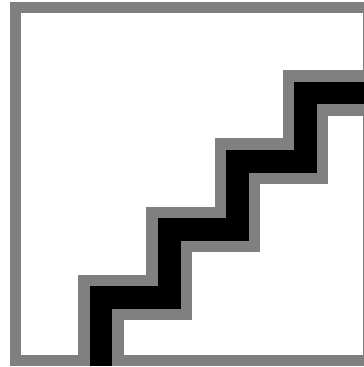

~ 2000 giri/min 13V/1,5÷2A
> 4000 giri/min 14÷14,5V > 4A

avoid damaging the instrument measuring the current).

Check the voltage at idle is at least 13V (charged battery) and the recharge current is 1.5 - 2A with the lighting system and the choke device excluded, as described in the chapter "CHECKING THE VOLTAGE REGULATOR".

As the engine speed increases, so do the recharge current and voltage, and at speeds above 4,000 rpm, a recharging current of approx. 4.5A must be observed; reactivating the lighting system and choke device, and operating the stop light and horn, current values of $\geq 5A$ may be found, with voltage readings of 14 - 14.5V (regulator threshold voltage).

If the readings do not match the above figures, replace the regulator; otherwise check wiring and connections.

Electric characteristic

Resistance of voltage regulator

~ 8 M Ω

Turn signals system check

4) TURN INDICATORS FAIL TO OPERATE

In case of turn indicators fault, proceed as follows:

- Remove the regulator connector and insert the multimeter prods between white wire (3) and black wire (2).
- Turn the key switch to ON and check that the battery is powered. If no voltage is measured, repeat the test between the earth and white cable. If the check is still unsuccessful, check the cables and the contacts on the key switch and battery. If the battery voltage is measured, check the regulator earth cables (black cable)
- If the above checks are successful, jump contacts 5 (blue/black) and 3 (white) on the connector, turn

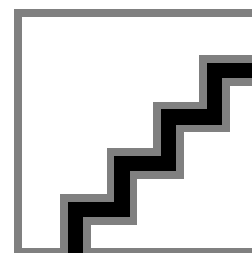
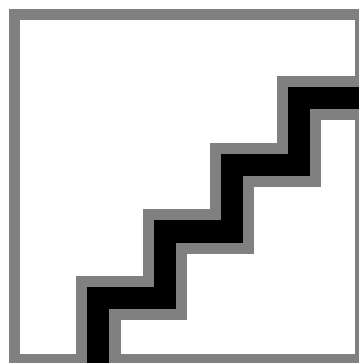

the key switch to ON and turn the flashlights switch to the left and to the right to check if lights goes on (these are directly fed by the battery).

If the flashlights do not go on, check the cables and the switch operation; otherwise, replace the regulator since it is faulty.

Specific tooling

020331Y Digital multimeter

Sealed battery

INSTRUCTIONS FOR REFRESHING THE STOCK CHARGE OF AN OPEN CIRCUIT

1) Voltage check

Before installing the battery on the vehicle, check the open circuit voltage with a normal tester.

- If the voltage exceeds 12.60 V, the battery may be installed without any renewal recharge.
- If voltage is below 12.60 V, a renewal recharge is required as explained in 2).

2) Constant voltage battery charge mode

- Constant voltage equal to 14.40÷14.70V
- Initial charge voltage equal to 0.3÷0.5 for nominal capacity
- Duration of the charge: 10 to 12 h recommended

Minimum 6 h

Maximum 24 h

3) Constant current battery charge mode

- Charge current equal to 1/10 of the nominal capacity of the battery
- Duration of the charge: 5 h

WARNING

-WHEN THE BATTERY IS REALLY FLAT (WELL BELOW 12.6V) IT MIGHT BE THAT 5 HOURS OF RECHARGING ARE NOT ENOUGH TO ACHIEVE OPTIMAL PERFORMANCE. IN THESE CONDITIONS IT IS HOWEVER ESSENTIAL NOT TO EXCEED EIGHT HOURS OF CONTINUOUS RECHARGING SO AS NOT TO DAMAGE THE BATTERY ITSELF.

Dry-charge battery

WARNING

- Battery electrolyte is toxic and it may cause serious burns. It contains sulphuric acid. Avoid contact with eyes, skin and clothing. In case of contact with eyes or skin, flush abundantly with water for about 15 minutes and seek immediate medical attention.

In the event of accidental ingestion of the fluid, immediately drink large quantities of water or milk. Follow with milk of magnesia, beaten egg or vegetable oil. Seek immediate medical attention

Batteries produce explosive gases; keep clear of free flames, sparks or cigarettes; ventilate the area when recharging the battery indoors.

Always protect your eyes when working close to batteries.

Keep out of the reach of children.

The battery is an electrical device which requires careful monitoring and diligent maintenance. The maintenance rules are:

1) Check the level of the electrolyte

The electrolyte level must be checked frequently and must reach the upper level. Only use distilled water, to restore this level.

If it is necessary to add water too frequently, check the vehicle's electrical system: the battery works overcharged and is subject to quick wear.

2) Load status check

After restoring the electrolyte level, check its density using an appropriate densitometer (see the figure).

When the battery is charged, you should detect a density of 30 to 32 Bé corresponding to a specific weight of 1.26 to 1.28 at a temperature of no lower than 15° C.

A density reading of less than 20° Bé indicates that the battery is completely flat and it must therefore be recharged.

After charging the battery, check each element electrolyte level and density. If the scooter is not used for a given time (1 month or more) it will be necessary to periodically recharge the battery.

The battery runs down completely in the course of three months.

If it is necessary to refit the battery in the vehicle, be careful not to reverse the connections, remembering that the earth wire (**black**) marked (-) must be connected to the - **negative** terminal while the other two **red** wires marked (+) must be connected to the terminal marked with the + **positive** sign.

Regular bench charging must be carried out with the specific battery charger, (single) or (multiple), setting the battery charger selector to the type of battery to be recharged. Connections to the power

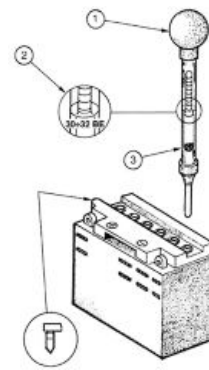

supply source must be implemented by connecting the corresponding poles (+ to+ and - to -).

4) Cleaning the battery

The battery should always be kept clean, especially on its top side, and the terminals should be coated with Vaseline.

WARNING

- Before recharging the battery, remove the plugs of each cell. Keep the battery away from naked flames or sparks when charging. Remove the battery from the vehicle removing the negative clamp first.

CAUTION

NEVER USE FUSES WITH A CAPACITY HIGHER THAN THAT RECOMMENDED. USING A FUSE OF UNSUITABLE RATING MAY SERIOUSLY DAMAGE THE VEHICLE OR EVEN CAUSE A FIRE.

CAUTION

DRINKING WATER CONTAINS MINERALS THAT CAN BE EXTREMELY HARMFUL TO THE BATTERY: USE DISTILLED WATER ONLY.

CAUTION

TO ENSURE MAXIMUM PERFORMANCE THE BATTERY MUST BE CHARGED BEFORE USE. INADEQUATE CHARGING OF THE BATTERY WITH A LOW ELECTROLYTE LEVEL BEFORE IT IS FIRST USED SHORTENS THE LIFE OF THE BATTERY.

Specific tooling

020333Y Single battery charger

020334Y Multiple battery charger

- 1)- Remove the short closed tube and the caps, then pour sulphuric acid into the cells using the type specified for batteries, with a specific gravity of 1.26, corresponding to 30° Bé, at a minimum temperature of 15°C until the upper level is reached.
- 2) - Leave to rest for at least 2 hours; then, restore the level with sulphuric acid.
- 3)- Within the following 24 hours, recharge with the specific battery charger (single) or (multiple) at a density of about 1/10 of the battery nominal capacity and until the acid density is about 1.27, corresponding to 31° Bé, and these values are stabilised.
- 4) - Once the charge is over, level the acid (by adding **distilled water**). Close and clean carefully.
- 5)- Once the above operations have been performed, install the battery in the vehicle ensuring the connections between the wiring and the battery terminals are correct.

WARNING

- ONCE THE BATTERY HAS BEEN INSTALLED IN THE VEHICLE IT IS NECESSARY TO REPLACE THE SHORT TUBE (WITH CLOSED END) NEAR THE + POSITIVE TERMINAL WITH THE CORRE-

SPONDING LONG TUBE (WITH OPEN END), THAT YOU FIND FITTED TO THE VEHICLE, TO ENSURE THAT THE GASES THAT FORM CAN ESCAPE PROPERLY.

Specific tooling

020333Y Single battery charger

020334Y Multiple battery charger

INDEX OF TOPICS

ENGINE FROM VEHICLE

ENG VE

Exhaust assy. Removal

- Remove the 2 fixing nuts from the manifold to the head

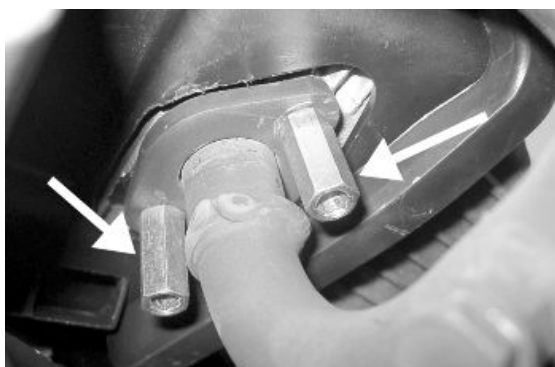

- Unscrew the 2 screws fixing the muffler to the housing; then remove the whole muffler paying attention to the interference between its supporting bracket and the cooling cover.

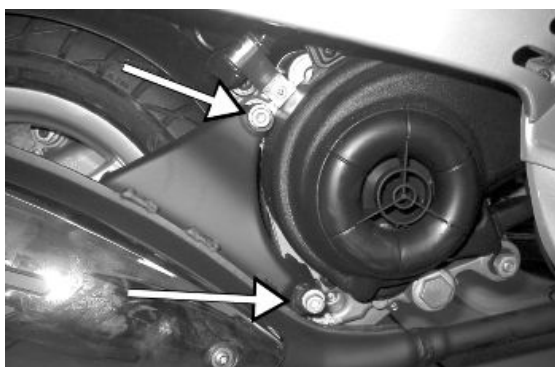

Removal of the engine from the vehicle

Removing the engine from the frame

- Disconnect the battery.
- Remove the muffler assembly.
- Remove the rear wheel.
- Remove the rear brake mechanical transmission.
- Disconnect the electric terminals.
- Remove the throttle grip transmission.
- Disconnect the tubing (petrol-vacuum operated cock control).
- Disconnect the swinging arm on the engine side
- Disconnect the rear shock absorber lower clamping

WARNING

Be very careful when handling fuel.

CAUTION

When installing the battery, first attach the positive cable and then the negative cable.

WARNING

Wear safety goggles when using hitting tools.

INDEX OF TOPICS

ENGINE

ENG

Automatic transmission

Transmission cover

- Remove the 12 fixing screws.
- Remove the oil filling cap and then slide out the cover.

If this operation is carried out directly on the vehicle, it is necessary to remove the transmission cooling coupling and the air filter housing retainers.

N.B.

USE A MALLET ON THE APPROPRIATE COUPLINGS TO REMOVE THE COVER.

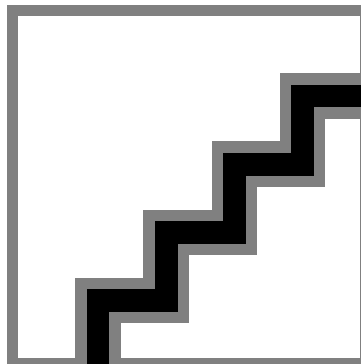

Kickstart

- To remove the start up pinion push the starter lever to facilitate extracting the pinion.
- Remove the kick-start screw and lever.
- Remove the seeger ring and the washer indicated in the figure.
- Pull out the toothed sector.

WARNING

THE SECTOR KEEPS THE SPRING SET, BE CAREFUL SO AS NOT TO CAUSE ANY ACCIDENTS

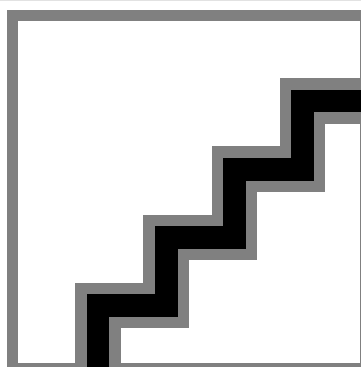

Air duct

- To remove the intake throat on the transmission cover, just remove the three fixing screws indicated in the figure.

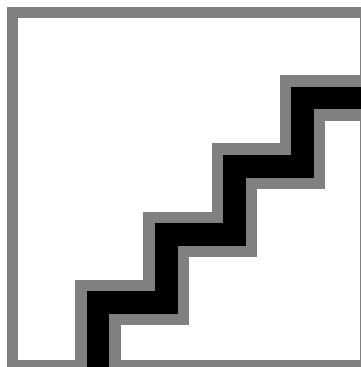

Removing the driven pulley shaft bearing

- Slightly heat the crankshaft from the inside side to avoid damaging the coated surface and use the driven pulley shaft or a pin of the same diameter to remove the bearing.

N.B.

IN CASE OF DIFFICULTY A STANDARD 8MM-INSIDE DIAMETER EXTRACTOR CAN BE USED.

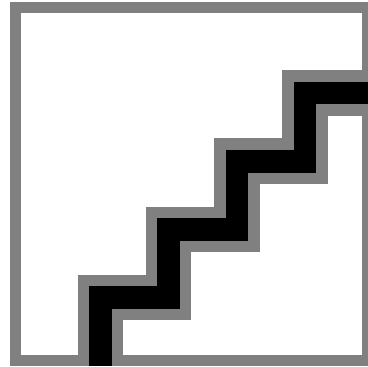

Refitting the driven pulley shaft bearing

Refit the bearing with the aid of a bushing with the same diameter as the external plate of the bearing after slightly heating the crankcase from the inside.

N.B.

WHEN REFITTING, ALWAYS REPLACE THE BEARING WITH A NEW ONE.

CAUTION

WHEN REMOVING/REFITTING THE BEARING, TAKE CARE NOT TO DAMAGE THE COVER PAINTED SURFACE.

Removing the driven pulley

- Lock the clutch bell housing with the specific tool.
- Remove the nut, the clutch bell housing and the whole of the driven pulley assembly.

N.B.

THE UNIT CAN ALSO BE REMOVED WITH THE DRIVE PULLEY MOUNTED.

Specific tooling

020565Y Flywheel lock calliper spanner

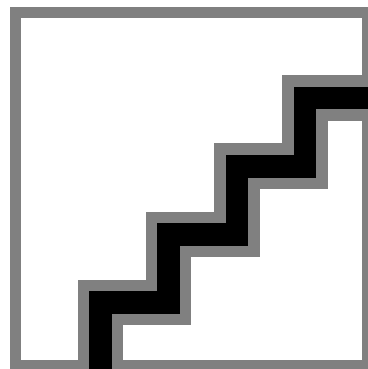

Inspecting the clutch drum

- Check that the clutch bell is not worn or damaged.
- Measure the inner diameter of the clutch bell.

Characteristic

Clutch bell diameter/standard value

Ø 107+0.2 +0 mm

Clutch bell diameter/max. value allowed after use

Ø 107.5 mm

Eccentricity measured /max.

0.20 mm

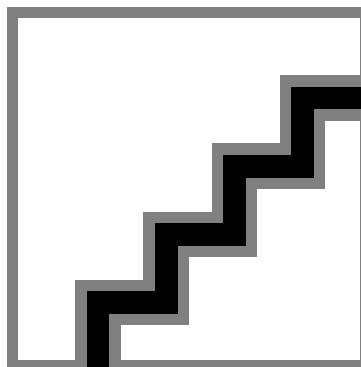

Removing the clutch

- Equip the tool with long pins screwed into position «A» from the outside, insert the entire driven pulley in the tool and have the central screw make contact.

CAUTION

THE TOOL WILL BE DEFORMED IF THE CENTRAL SCREW IS TIGHTENED UP TOO FAR.

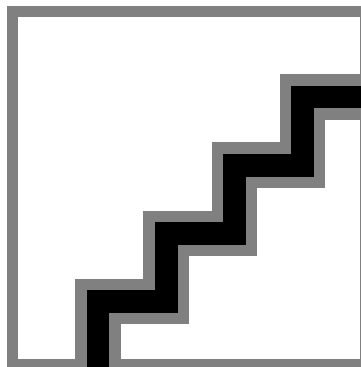

- Using a 34 mm socket wrench remove the clutch locking nut.
- Loosen the central screw by undoing spring of the driven pulley unit
- Separate the components.

Specific tooling

020444Y Tool for fitting/ removing the driven pulley clutch

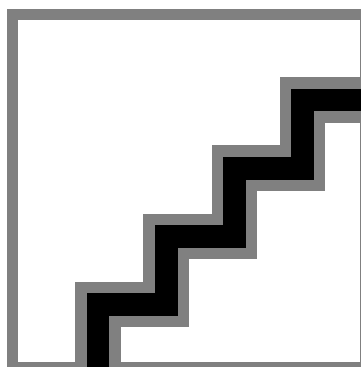

Inspecting the clutch

- Check the thickness of the clutch mass friction material.
- The masses must not show traces of lubricants; otherwise, check the driven pulley unit seals.

N.B.

UPON RUNNING-IN, THE MASSES MUST EXHIBIT A CENTRAL CONTACT SURFACE AND MUST NOT BE DIFFERENT FROM ONE ANOTHER.

VARIOUS CONDITIONS CAN CAUSE THE CLUTCH TO TEAR.

CAUTION

DO NOT OPEN THE MASSES USING TOOLS TO PREVENT A VARIATION IN THE RETURN SPRING LOAD.

Characteristic

Check minimum thickness

1 mm

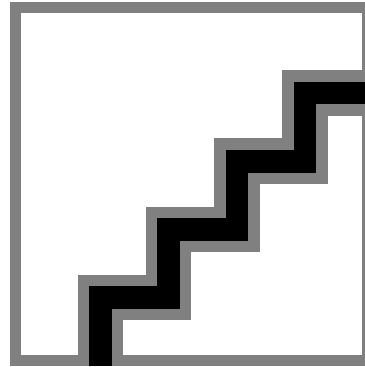

Pin retaining collar

- Remove the collar with the aid of 2 screwdrivers.

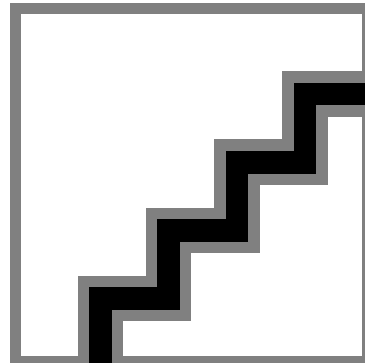

- Remove the three guide pins and the mobile half pulley.

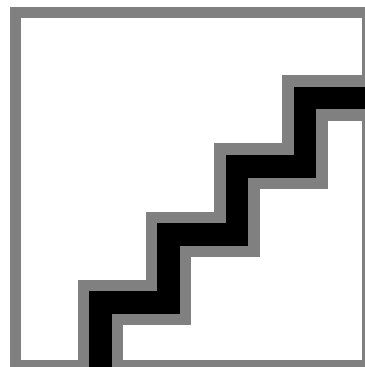

Removing the driven half-pulley bearing

- Remove the roller bearing with the special extractor inserted from the bottom of the fixed half-pulley.

CAUTION

POSITION THE HOLDING EDGE OF THE EXTRACTION PLIERS BETWEEN THE END OF THE BEARING AND THE BUILT IN SEALING RING.

Specific tooling

001467Y029 Bell for bearings, O.D. 38 mm

- Remove the ball bearing retention snap ring.
- Expel the ball bearing from the side of the clutch housing by means of the special tool.

N.B.

PROPERLY SUPPORT THE HALF-PULLEY SO AS NOT TO DEFORM THE SLIDING SURFACE OF THE DRIVING BELT

Specific tooling

020376Y Adaptor handle

020363Y 20 mm guide

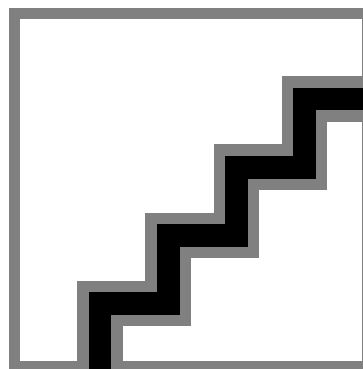
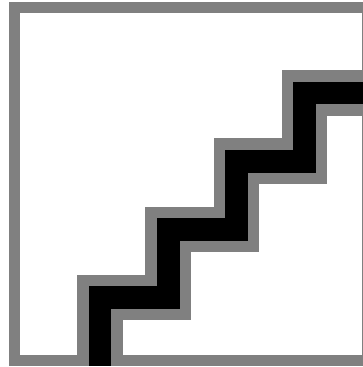

Inspecting the driven fixed half-pulley

- Check that there are no signs of wear on the work surface of the belt. If there are, replace the half-pulley..
- Make sure the bearings do not show signs of unusual wear.
- Measure the external diameter of the pulley bushing.

Characteristic

Stationary driven half-pulley/Standard diameter

Ø 33.965 to 33.985 mm

Stationary driven half-pulley / Minimum diameter admitted after use

Ø 33.96 mm

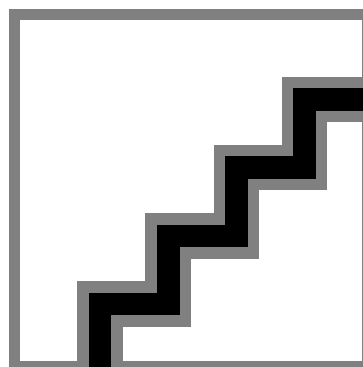

Inspecting the driven sliding half-pulley

- Remove the 2 inner sealing rings and the two O-rings.
- Measure the inside diameter of the mobile half-pulley bushing.

Characteristic

Mobile driven half-pulley/ Maximum diameter allowed

Ø 34.08 mm

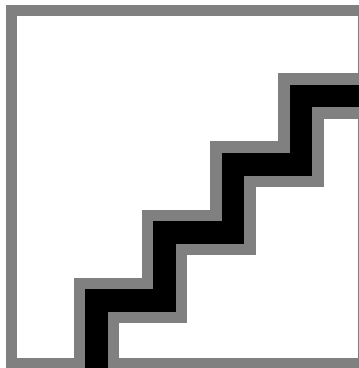

- Check the belt contact surfaces.
- Insert the new oil seal and O-rings on the mobile half-pulley.
- Fitting the half-pulley on the bushing.

Recommended products

AGIP GREASE SM 2 Grease for the tone wheel revolving ring

Soap-based lithium grease containing NLGI 2 Molybdenum disulphide; ISO-L-XBCHB2, DIN KF2K-20

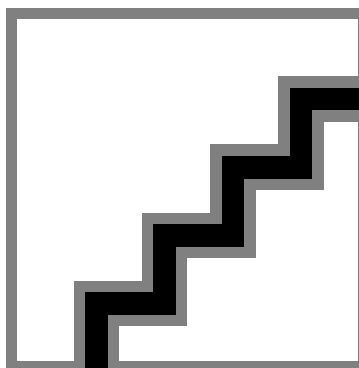

- Make sure the pins and collar are not worn, reassemble the pins and collar.
- Use a greaser with a curved spout to lubricate the driven pulley unit with around 6 gr. of grease. This operation must be done through one of the holes inside the bushing until grease comes out of the opposite hole. This procedure is necessary to prevent the presence of grease beyond the O-ring.

Recommended products

AGIP GREASE SM 2 Grease for the tone wheel revolving ring

Soap-based lithium grease containing NLGI 2 Molybdenum disulphide; ISO-L-XBCHB2, DIN KF2K-20

Refitting the driven half-pulley bearing

- Fit a new ball bearing with the specific tool.
- Fit the ball bearing retention snap ring.
- Fit the new roller bearing with the wording visible from the outside.

CAUTION

PROPERLY SUPPORT THE HALF-PULLEY TO PREVENT DAMAGE TO THE THREADED END WHILE THE BEARINGS ARE BEING FITTED.

Specific tooling

020376Y Adaptor handle

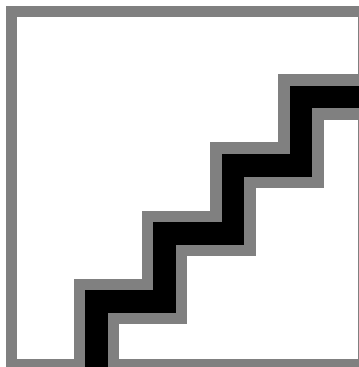

020456Y Ø 24 mm adaptor

020362Y 12 mm guide

020171Y Punch for Ø 17 mm roller case

Inspecting the clutch spring

- Check that the contrast spring of the driven pulley does not show signs of deformation
- Measure the free length of the spring

Characteristic

Standard length

118 mm

Minimum length allowed after use

XXXX

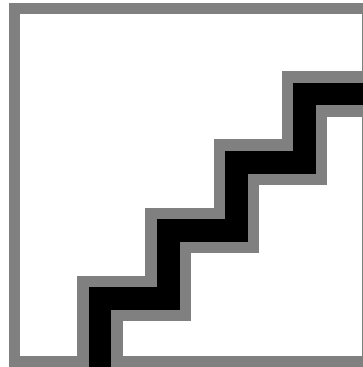

- Check the thickness of the clutch mass friction material.
- The masses must not show traces of lubricants; otherwise, check the driven pulley unit.

N.B.

UPON RUNNING-IN, THE MASSES MUST EXHIBIT A CENTRAL CONTACT SURFACE AND MUST NOT BE DIFFERENT FROM ONE ANOTHER. VARIOUS CONDITIONS CAN CAUSE THE CLUTCH TO TEAR.

CAUTION

DO NOT OPEN THE MASSES USING TOOLS SO AS TO PREVENT A VARIATION IN THE RETURN SPRING LOAD.

Characteristic

Minimum thickness permitted:

1 mm

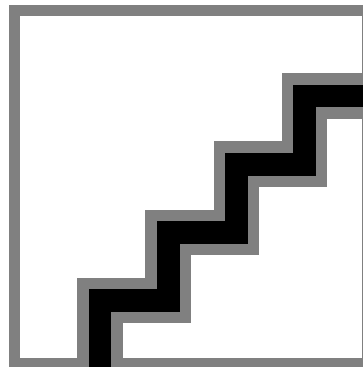

Refitting the clutch

- Preassemble the driven pulley group with spring, sheath and clutch.
- Position the spring with the sheath
- Insert the components in the tool and preload the spring being careful not to damage the plastic sheath and the end of the threaded bar.

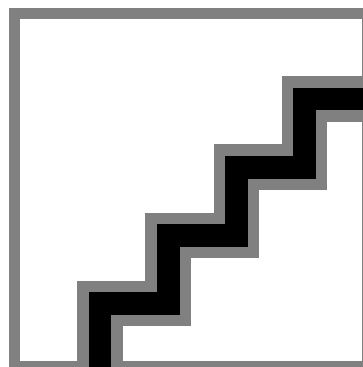

-
- Reassemble the nut securing the clutch and tighten to the prescribed torque.

CAUTION

SO AS NOT TO DAMAGE THE CLUTCH NUT USE A SOCKET WRENCH WITH SMALL CHAMFER.

CAUTION

POSITION THE NON-CHAMFERED SURFACES OF THE NUT IN CONTACT WITH THE CLUTCH

Locking torques (N*m)

Nut locking clutch unit on pulley 55 ÷ 60 Nm

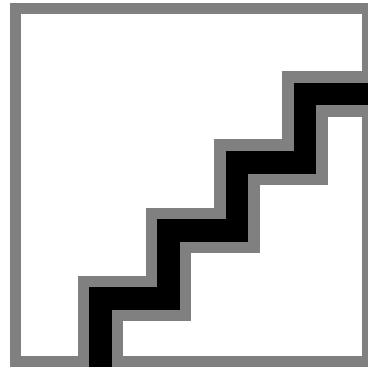
**Refitting the driven pulley**

-
- Refit the driven pulley assembly, the clutch bell and the nut, using the specific tool.

Specific tooling

020565Y Flywheel lock calliper spanner

Locking torques (N*m)

Driven pulley shaft nut 40 to 44 Nm

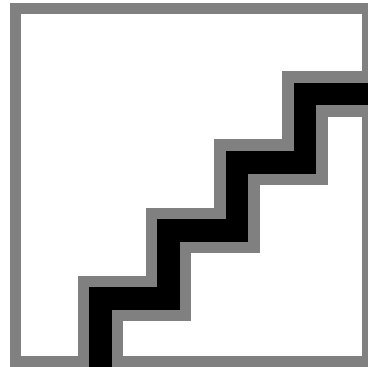
**Drive-belt**

-
- Make sure the driving belt is not damaged and does not have cracks in the toothed grooves.
 - Check the width of the belt.

Characteristic

Transmission belt/Minimum width

17.5 mm

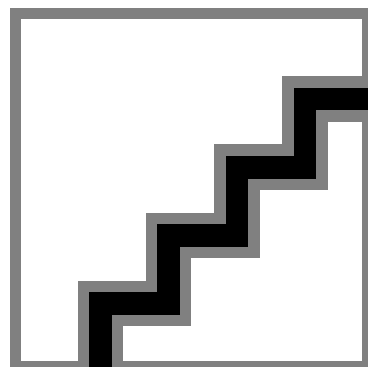

Removing the driving pulley

- Lock the driving pulley using the appropriate tool.
- Remove the central nut with the related washer, then remove the drive and the plastic fan.
- Remove the stationary half-pulley.

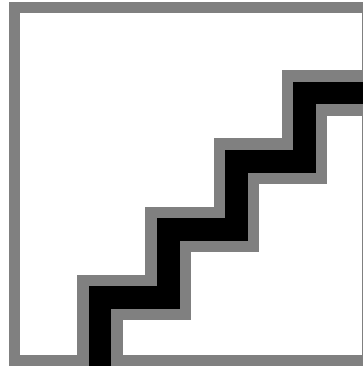

- Remove the belt, washer and remove the mobile half-pulley with its bushing, being careful that the rollers and contrast plate fitted loosely on it do not come off.

Specific tooling

020451Y Start-up crown lock

Inspecting the rollers case

- 1) Check that the bushing and the sliding rings of the mobile pulley do not show signs of scoring or deformation.
- 2) Check the roller running tracks on the contact pulley; there must not be signs of wear and check the condition of the contact surface of the belt on the half-pulleys (mobile and stationary).
- 3) Check that the rollers do not show signs of marked facetting on the sliding surface and that the metallic insert does not come out of the plastic shell borders.
- 4) Check the integrity of the sliding blocks of the contact plate.

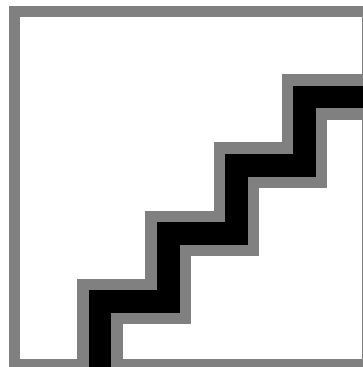

- Check that the internal bushing shown in the figure is not abnormally worn and measure inside diameter «A».
- Measure outside diameter «B» of the pulley sliding bushing shown in the figure.

CAUTION

DO NOT LUBRICATE OR CLEAN THE BUSHING.

Characteristic

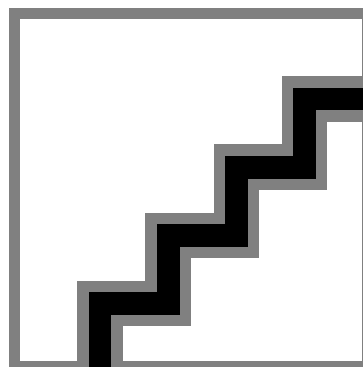

Driving pulley / Maximum diameter:

20.12 mm

Driving pulley/ Standard diameter:

20.021 mm

Driving pulley bushing/ Diameter maximum:

XXX mm

Driving pulley bushing/ Standard diameter:

20 -0.020/-0.041mm

Refitting the driving pulley

- Manually move the mobile driven half-pulley away pulling it towards the clutch unit and insert the belt repeating the direction of rotation of the first fitting.

N.B.

IT IS GOOD PRACTICE ALWAYS TO FIT THE BELT SO THE WORDING CAN BE READ, IN THE CASE THAT THIS DOES NOT SHOW A FITTING SIDE.

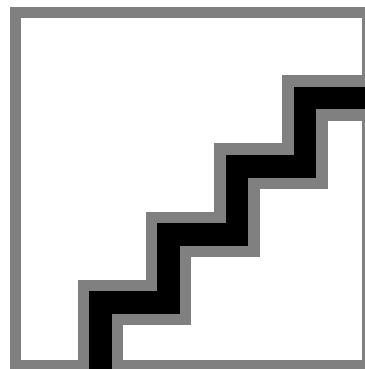

- Refit the particular components of the assembly (roller container assembly with bushing, limiting washer, stationery half-pulley, cooling fan belt with drive, washer and nut).

- Tighten the lock nut to torque 20 Nm and then perform a final 90° lock preventing the rotation of the drive pulley with the specific tooling.

N.B.

REPLACE THE NUT WITH A NEW ONE AT EVERY REFIT

CAUTION

IT IS MOST IMPORTANT WHEN FITTING THE DRIVING PULLEY UNIT THAT THE BELT IS FREE INSIDE IN ORDER TO AVOID MAKING A WRONG TIGHTENING WITH THE POSSIBLE LATER DAMAGE OF THE CRANKSHAFT KNUURLING.

Specific tooling

020451Y Start-up crown lock

Locking torques (N*m)

Crankshaft pulley nut 18 to 20 + 90° N.m

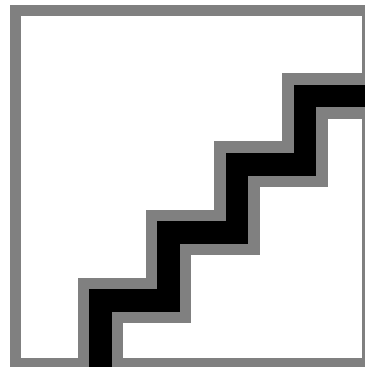

Refitting the transmission cover

- Check the following for wear: toothed section, toothed section shaft, cover seat bushing, pinion shaft and its seating in the crankcase and the return spring.
- Remove the damaged components.
- Grease the spring.
- Remove the toothed sector and load the spring with an appropriate tool.
- Refit the washer, the seeger and the Kick-start lever.

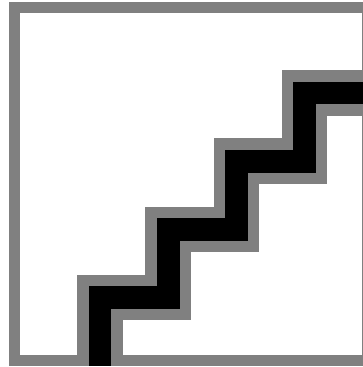

Recommended products

AGIP GREASE MU3 Grease for odometer transmission gear case

Soap-based lithium grease with NLGI 3; ISO-L-XBCHA3, DIN K3K-20

- Insert the pinion in its seating by pushing the starter lever.
- Fit the intake throat and tighten the 3 screws.

- Make sure the oil sump presents centring dowels and sealing gaskets.
- Replace the cover tightening the 12 screws to the prescribed torque.
- Refit the oil filling cap.

Locking torques (N*m)

Transmission cover screws 11 ÷ 13 Nm

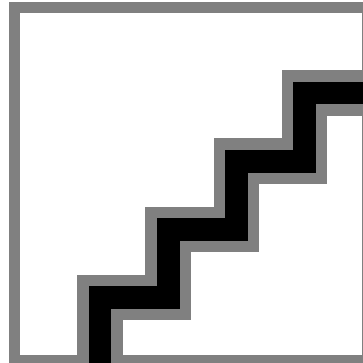

End gear

Removing the hub cover

- Remove the transmission cover
- Remove the clutch assembly
- Discharge the rear hub oil.
- Remove the 5 screws indicated in the figure.
- Remove the hub cover with driven pulley shaft.

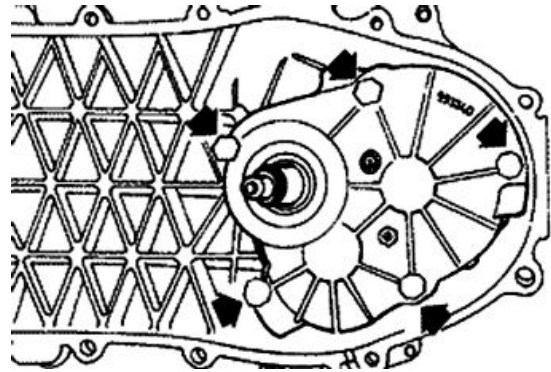

See also

[Refitting the clutch](#)

Removing the wheel axle

- Remove the intermediate gear and the complete gear wheel axle.
- When removing the intermediate gear pay attention to the various shim adjustments.

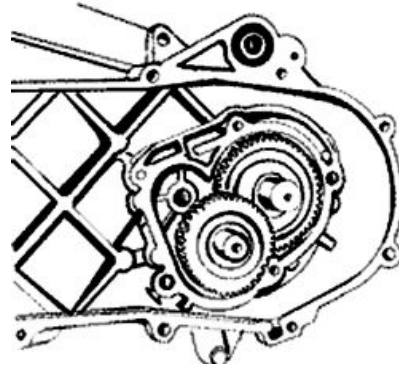

Removing the wheel axle bearings

- Remove the oil seal and the seeger ring.
- Remove the bearing by pushing from the outside towards the inside of the gear compartment, using the appropriate punch.

Specific tooling

020363Y 20 mm guide

020376Y Adaptor handle

020358Y 37x40-mm adaptor

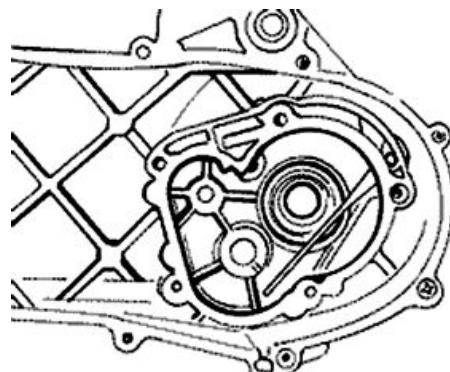

Removing the driven pulley shaft bearing

- Remove the seeger ring inside the cover.
- Remove the oil seal from the outside.
- Remove the centring dowels and position the cover on a plane.
- Position the special tool on the internal track of the bearing and remove said bearing with the aid of a press.

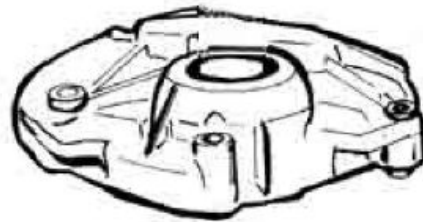

Specific tooling

020452Y Tube for removing and refitting the driven pulley shaft

- Position the special tube on the internal raceway of the bearing and from the shaft toothed side as indicated in the figure. Expel the driven pulley shaft with the aid of a press.

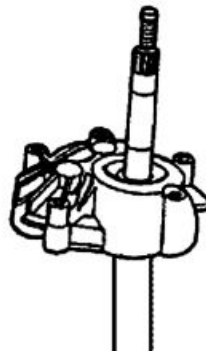

Specific tooling

020452Y Tube for removing and refitting the driven pulley shaft

Inspecting the hub shaft

- Check the three shafts for wear or distortion of the toothed surfaces, the bearing housings, and the oil seal housings.
- In case of anomalies, replace the damaged components.
- Check capacity (A) of the transmission gear (wear, deformations, etc.)
- Check the pulley shaft seating: Superficial wear (B) may indicate irregularities in the crankcase seatings or in the pulley shaft capacities

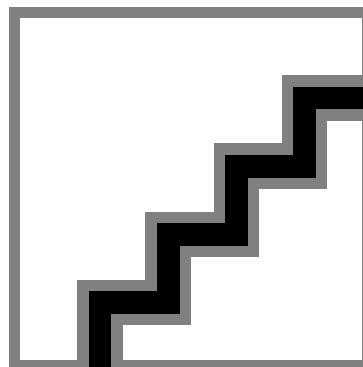

Inspecting the hub cover

- Check that the fitting surface is not dented or distorted.
- If faults are found, replace the hub cover.

Refitting the driven pulley shaft bearing

- Support the inner track of the bearing from the outside of the hub cover with the specific tool positioned under the press and insert the driven pulley axle.
- Refit the oil seal flush with the cover.

Specific tooling

020452Y Tube for removing and refitting the driven pulley shaft

- Heat the hub cover and insert the bearing with the specific punch.
- Fit the snap ring with the concave or radial part on the bearing side.

N.B.

FIT THE BALL BEARING WITH THE SHIELD FACING THE OIL SEAL.

Specific tooling

020151Y Air heater

020376Y Adaptor handle

020439Y 17 mm guide

020358Y 37x40-mm adaptor

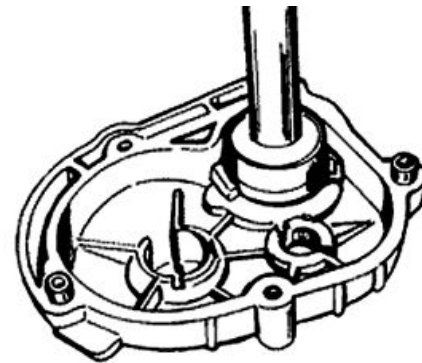
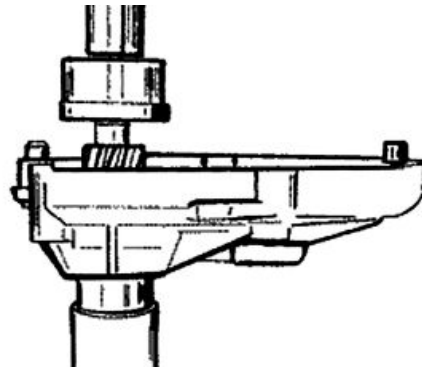

Refitting the wheel axle bearing

- Heat the half crankcase on the transmission side using a thermal gun.
- After lubricating its outer strip, insert the bearing with the special adapter with the aid of a hammer.
- Refit the seeger ring and the oil seal using the 42 x 47 mm adapter and the handle.

Specific tooling

020151Y Air heater

020376Y Adaptor handle

020363Y 20 mm guide

020359Y 42x47-mm adaptor

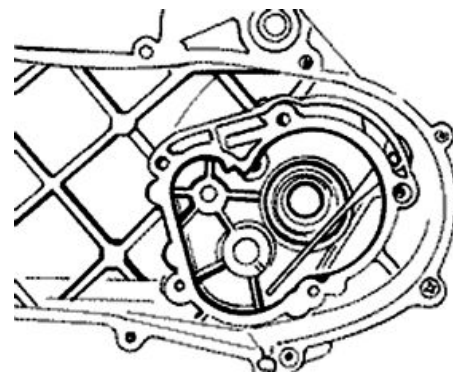

Refitting the ub cover

- Refit the whole wheel axle.
- Refit the intermediate gear paying attention to the two shim thicknesses.
- Apply LOCTITE 510 for surfaces to the hub covers and refit the same with driven pulley shaft.
- Refit the 5 screws and tighten them to the specified torque.

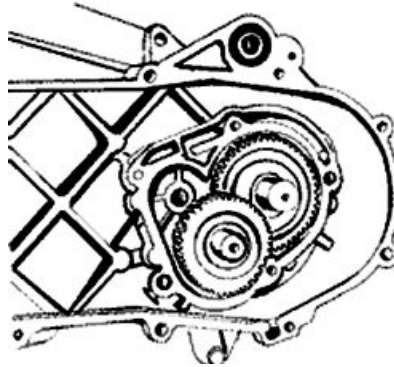

N.B.

CLEAN THE CONTACT SURFACES OF THE HUB COVER AND THE HALF CRANKCASE OF RESIDUE FROM PREVIOUS GASKETS BEFORE APPLYING A NEW ONE.

Locking torques (N*m)

Locking torque: 11 to 13 Nm

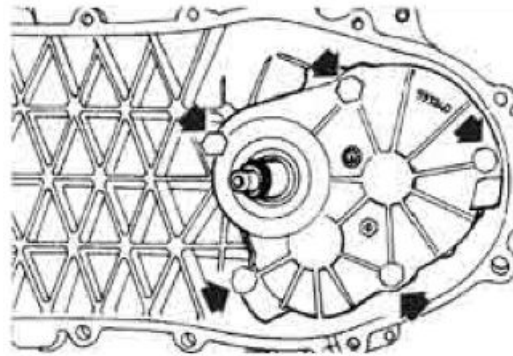

Flywheel cover

Cooling hood

- Remove the manifold and the carburettor undoing the 2 fixing screws on the head
- Remove the fastening clamp of the secondary air pipe and disconnect it
- Remove the 4 front coupling screws (1 of them is a knob) and the side fixing screw at the crankcase base.
- Remove the 4 side screws
- Extract the 3 covers - Remove the cover sealing gaskets on the head
- For refitting, repeat the removal steps but in reverse order

CAUTION

TAKE CARE TO CORRECTLY POSITION THE FLYWHEEL CONNECTOR.

N.B.

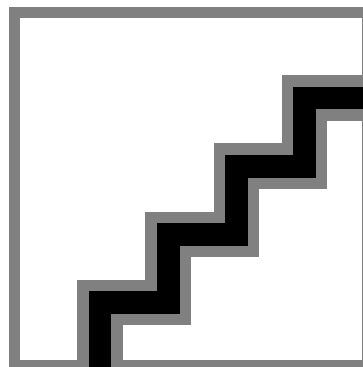

WHEN REFITTING THE COVER, TAKE CARE NOT TO DAMAGE THE STATOR WIRING.

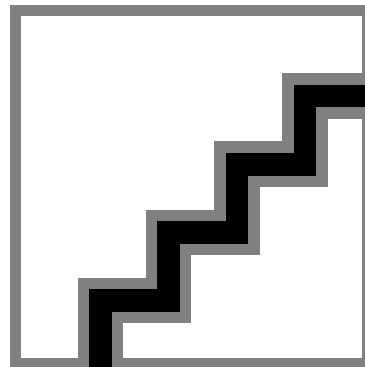
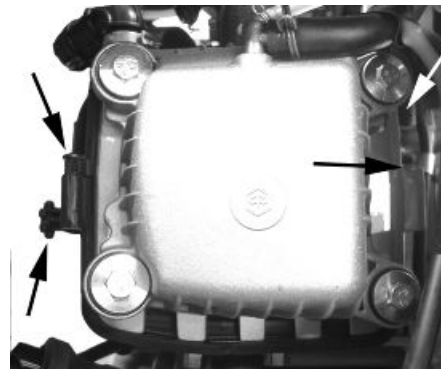

Cooling fan

- Remove the cooling fan by undoing the 3 screws fixing it to the rotor
- When refitting the fan, pay attention that the screw holes in the fan and the rotor coincide, then tighten screws at the specified torque.

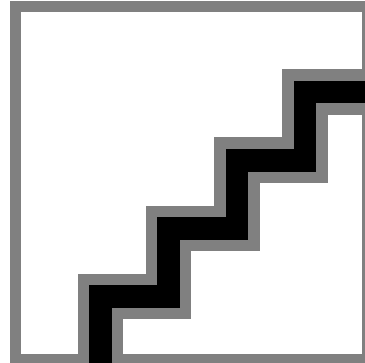

Removing the stator

- Remove the 2 Pick-Up screws and the 2 stator fixing screws indicated in the figure.
- Remove the stator and its wiring.

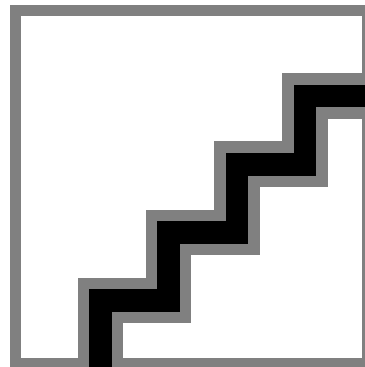

Refitting the stator

- Refit the stator and flywheel carrying out the removal procedure in reverse, tightening the retainers to the specified torque.

N.B.

THE PICK-UP CABLE MUST BE POSITIONED ADHERING TO THE FUSION TONGUE ON THE CRANKSHAFT IN SUCH A WAY AS TO AVOID BEING CRUSHED BY THE FAN COVER ASSEMBLY.

Locking torques (N*m)

Pick-up screws 3 ÷ 4 Stator screws 3 ÷ 4

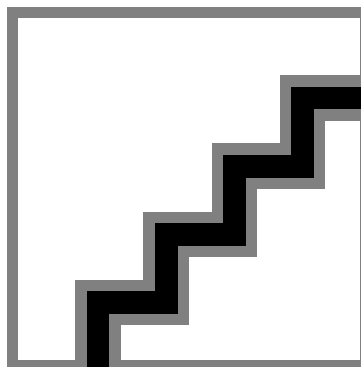

Flywheel and starting

Removing the starter motor

- Unscrew the screw on the power positive contact and disconnect the cable
- Unscrew the 2 screws fixing the starter motor to the crankcase and recover the power wiring.

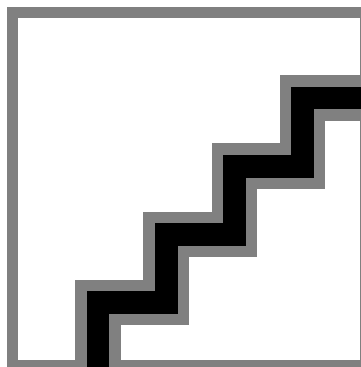
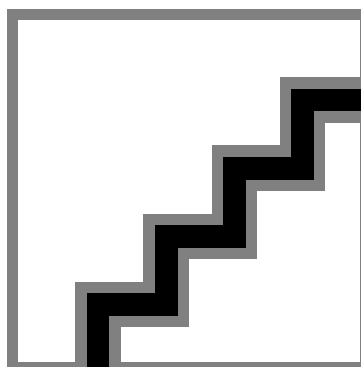

Removing the flywheel magneto

- Lock the rotation of the flywheel using the calliper spanner.
- Remove the nut.

CAUTION

THE USE OF A CALLIPER SPANNER OTHER THAN THE ONE SUPPLIED COULD DAMAGE THE STATOR COILS

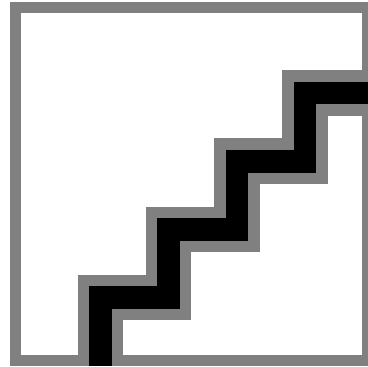

- Extract the flywheel with the extractor.

Specific tooling

020565Y Flywheel lock calliper spanner

020162Y Flywheel extractor

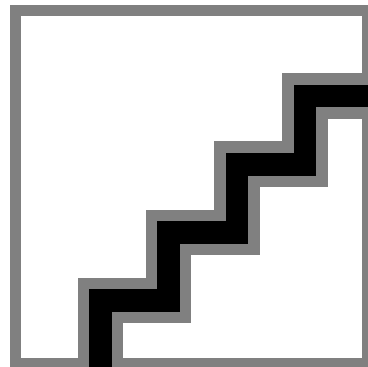

Inspecting the flywheel components

- Check that the flywheel internal magnets are in good conditions.
- Check that the flywheel riveted joints are correctly tightened.
- Check there are no deformations that may cause rubbing on the stator and the Pick-Up.
- Check that the stator winding, its ferromagnetic support and the pick-up are in good conditions.

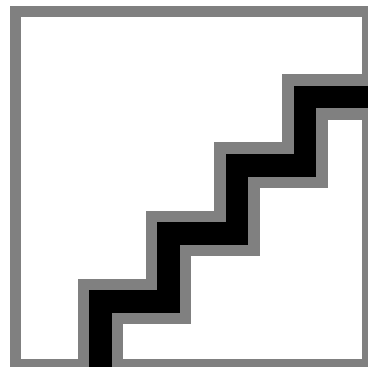

Starter gear rim

- Check the tothing is level and in good conditions

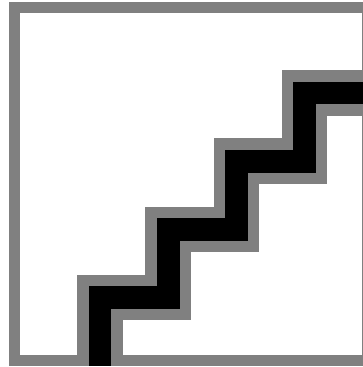

Intermediate gear

- Check that the keying tothing on the crown and the starter motor are in good conditions.
- Check that the bendix opens and returns adequately.

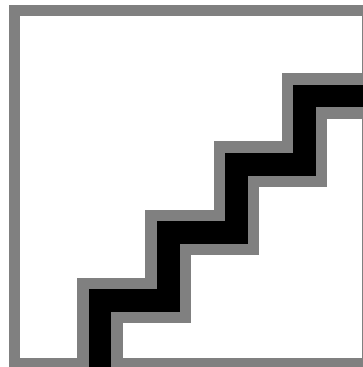

Refitting the flywheel magneto

- Refit the stator and the pick-up being careful to pass the wiring through the appropriate crankcase couplings.
- Refit the flywheel to the crankshaft being careful to respect the keying, then lock rotation with the specific tool and tighten the nut to the prescribed torque.

N.B.

A VARIATION OF THE AIR GAP DISTANCE CAN LEAD TO A VARIATION IN THE IGNITION ADVANCE SUCH AS TO CAUSE PINGING, KNOCKING ETC.

Specific tooling

020565Y Flywheel lock calliper spanner

Locking torques (N*m)

Flywheel nut 52 ÷ 58

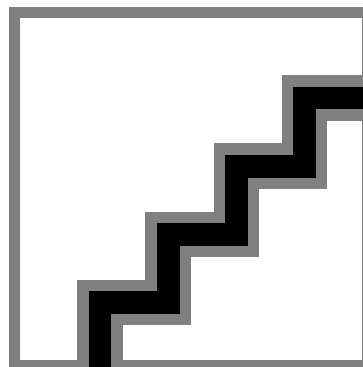

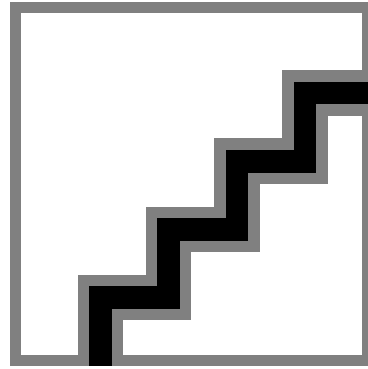

Refitting the starter motor

- Install the starter motor in its seating in the crankcase.
- Tighten the screw on the head side but do not lock it, screw the second screw inserting the earth cable (black), then tighten the 2 screws at the prescribed torque.
- Tighten the locking screw of the positive cable (red) on the side contact.

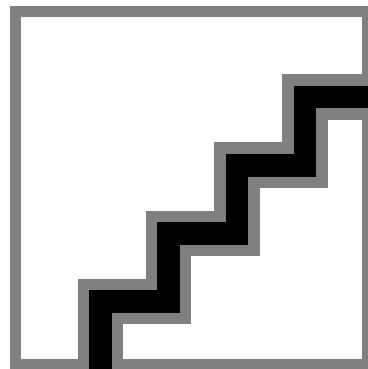

N.B.

REFIT THE REMAINING PARTS AS DESCRIBED IN THE CYLINDER HEAD, TIMING, LUBRICATION, FLYWHEEL AND TRANSMISSION CHAPTERS.

Locking torques (N*m)

Starter motor screws 11 ÷ 13

Cylinder assy. and timing system

Removing the rocker-arms cover

- Remove the cooling covers
- Remove the 4 retainers of the tappet cover
- Remove the cover and the O-ring
- Remove the 4 screws and then remove the Blow-by cover
- Clean the nozzle labyrinth and the membrane (replace it, if necessary), then remove the cover unit.

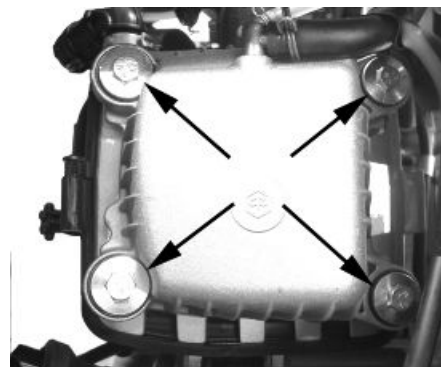



Removing the timing system drive

- Temporarily loosen the tensioner central screw and remove it together with the spring.
- Unscrew the 2 retainers indicated in the figure and remove the chain tightener support being careful to recover the sealing gasket.

N.B.

SHOULD THE GASKET NOT BE IN GOOD CONDITIONS, REPLACE IT AFTER CAREFULLY CLEANING THE FAYING SURFACE IN ORDER TO AVOID ENGINE OIL LEAKS

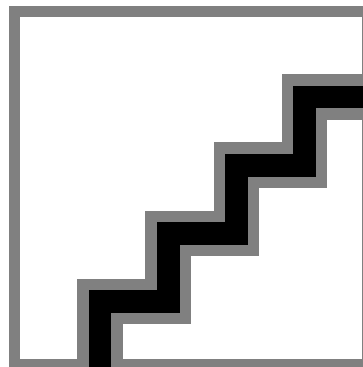

- Remove the driving pulley
- Remove the oil pump chain
- Remove the tappet cover
- Remove the central screw and the Belleville washer indicated in the figure and lock the camshaft crown with the specific tool.

N.B.

TO FACILITATE REMOVING THE HEAD COMPONENTS, SET THE CRANKSHAFT TO THE TIMING POINT (TDC OF THE COMPRESSION END).

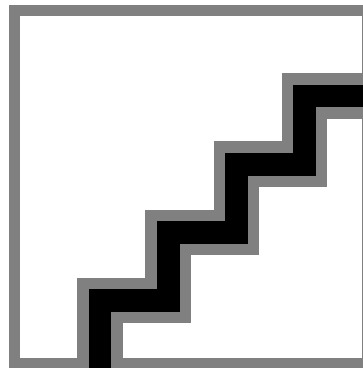

Specific tooling

020565Y Flywheel lock calliper spanner

- Remove the camshaft control pulley and the washer below.
- Remove the pinion of the crankshaft timing control
- To remove the chain lower guiding pad, remove the head by pulling it upwards

N.B.

IT IS ADVISABLE TO MARK THE CHAIN IN ORDER TO ENSURE THAT THE DIRECTION OF ROTATION IS MAINTAINED.

See also

[Removing the rocker-arms cover](#)

Removal
Removing the driving pulley

Removing the cam shaft

- Remove the bearing clamping screw indicated in the figure.

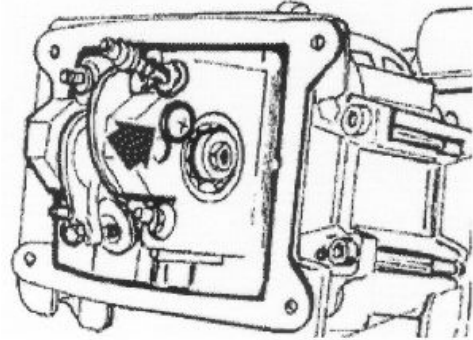

- Remove the entire camshaft with bearing using the specific tool shown in the figure.
- Take out the camshaft bearing with the aid of the specific tool, being careful to mount a screw on the camshaft in order to protect its thread.

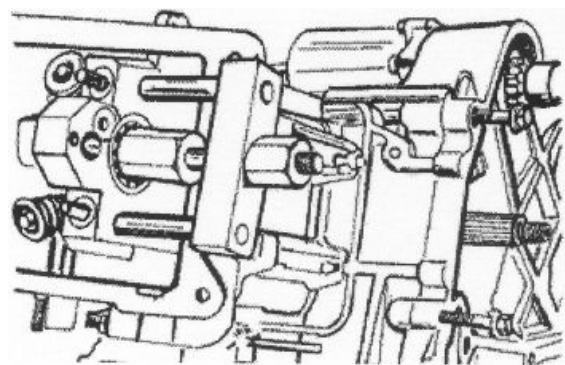

N.B.

IF A BEARING SEPARATES FROM THE CAM-SHAFT, IT IS ESSENTIAL TO FIT A NEW BEAR.

Specific tooling

020450Y Camshaft fitting/removal tool

004499Y Camshaft bearing extractor

004499Y001 Bearing extractor bell

004499Y002 Bearing extractor screw

004499Y006 Bearing extractor ring

004499Y027 Bearing extractor part

- Pull out the rocking lever bolt operating on the flywheel hole and remove the rocking levers at the same time.

N.B.

MARK THE ASSEMBLY POSITION OF THE ROCKING LEVERS IN ORDER TO AVOID MIS-PLACING THE INTAKE AND DISCHARGE ENDS.

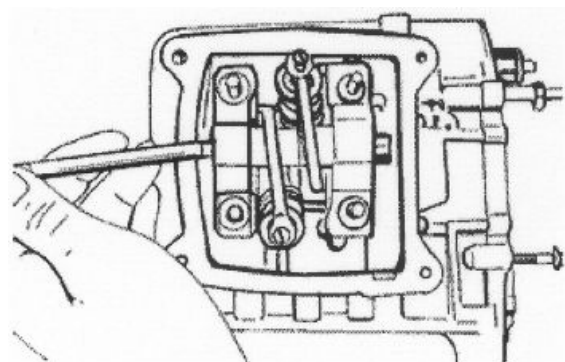

Removing the cylinder head

- Remove the cooling covers, the timing control, the camshaft and the rocking levers.
- Remove the spark plug.
- Remove the 2 side fixings shown in the figure.
- Loosen the 4 head-cylinder fastening nuts in two or three stages and in criss-cross fashion.
- Remove the head, the two centring dowels and the gasket.

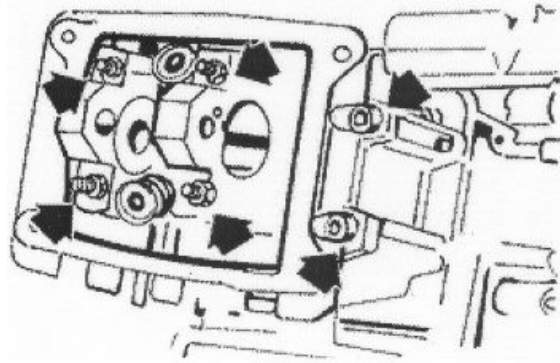

N.B.

IF NEEDED, THE HEAD MAY BE REMOVED WITH THE CAMSHAFT, PINS AND ROCKING LEVERS WITHOUT REMOVING THE DRIVING PULLEY UNIT. REMEMBER TO HOLD THE TIMING CHAIN WITH A PIECE OF METAL CABLE AND TO ADJUST THE CHAIN TIGHTENER UPON REFITTING.

Removing the valves

- Using the specific tool fitted with the element shown in the figure, remove the cotters, the plates and the spring between the valves.

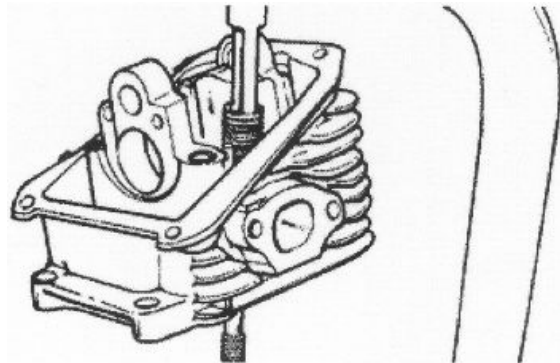

- Remove the oil seals with the appropriate tool.
- Remove the lower spring supports.

Specific tooling

020431Y Valve oil seal extractor

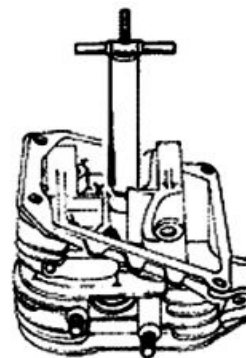

Removing the cylinder - piston assy.

- Remove the cylinder paying attention to the 2 cylinder centring dowels in the housing.

- Remove the cylinder base gasket.

To avoid damaging the piston, keep it fixed while removing the cylinder.

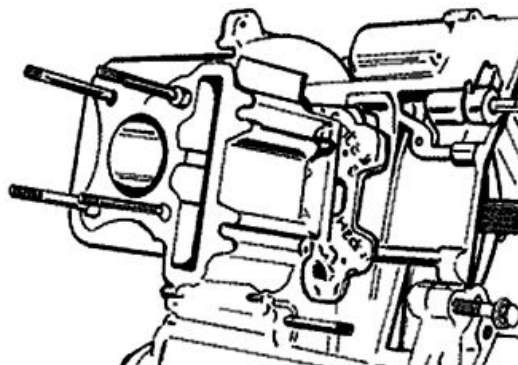

- Remove the two stop rings, the wrist pin and the piston.

- Remove the 3 piston rings.

N.B.

BE CAREFUL NOT TO DAMAGE THE PISTON RINGS DURING REMOVAL.

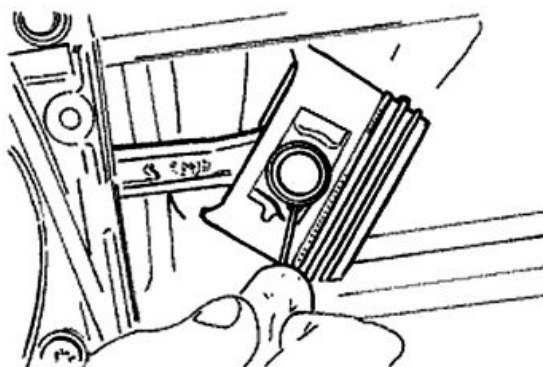

Inspecting the small end

- Measure the internal diameter of the small end using an internal micrometer.

N.B.

IF THE DIAMETER OF THE ROD SMALL END EXCEEDS THE MAXIMUM DIAMETER ALLOWED, SHOWS SIGNS OF WEAR OR OVERHEATING REPLACE THE CRANKSHAFT AS DESCRIBED IN THE "CRANKCASE AND CRANKSHAFT" CHAPTER".

Characteristic

Max. diameter admitted: check the small end

13.030 mm

Standard diameter check the small end

13 +0.025+0.015mm



Inspecting the wrist pin

- Measure the outer diameter of the gudgeon pin.

Characteristic

Standard diameter gudgeon pin

13 -0-0.004mm

Minimum admissible diameter pin

12.990 mm

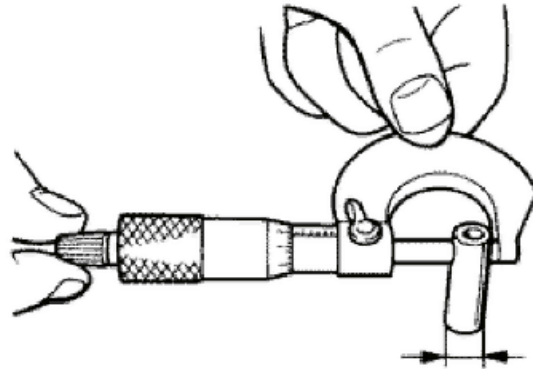

Inspecting the piston

- Carefully clean the sealing rings housings with the aid of an old piston ring.
- Measure the coupling clearance between the sealing rings and the piston grooves using a thickness gauge, as shown in the figure.
- If the clearances detected exceed the limits specified in the table, the piston and the piston rings should be replaced.

PISTON				
Name	Description	Dimensions	Initials	Quantity
Top piston ring		0.030 ÷ 0.065 mm		0.080 mm
Middle piston ring		0.020 ÷ 0.055 mm		0.070 mm
oil scraper		0.040 ÷ 0.160 mm		0.20 mm

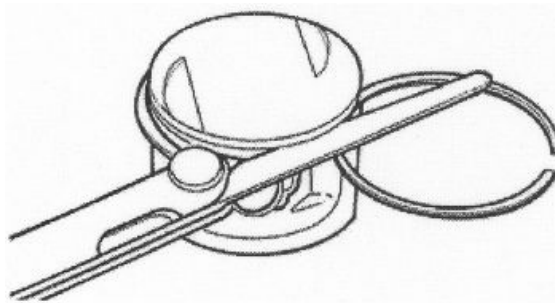

- Calculate the piston pin coupling clearance.

Fitting clearance

Pin coupling clearance 13 +0.010+0.005mm
0.005 ÷ 0.014 mm



- Measure the outside diameter of the piston, perpendicular to the gudgeon pin axis.
- Carry out the measurement at 27 from the piston crown as shown in the figure.

Inspecting the cylinder

- Using a bore meter, measure the inner cylinder diameter at three different points according to the directions shown in the figure.
- Check that the coupling surface with the head is not worn or misshapen.
- Pistons and cylinders are classified into categories based on their diameter. The coupling is carried out in pairs (A-A, B-B, C-C, D-D).

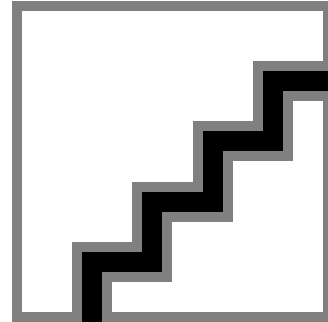

Characteristic

Maximum allowable run-out:

0.05 mm

- The cylinder rectifying operation should be carried out with a surfacing that respects the original angle. at 120° crossed.
- The cylinder surface roughness should be of R.A.= 0.30 ÷ 0.50.
- This is indispensable for a good seating of the sealing rings, which in turn minimises oil consumption and guarantees optimum performance.
- The pistons are oversized due to cylinder rectification and are subdivided into two categories 1st and 2nd with 0.2-0.4mm oversize. They are also classified into 4 categories A-A, B-B, C-C, D-D.

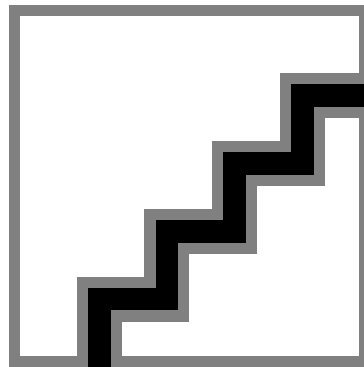

Inspecting the piston rings

- Alternately insert the three sealing rings into the cylinder, in the area where it retains its original diameter. Using the piston, insert the rings perpendicularly to the cylinder axis.
- Measure the opening, see figure, of the sealing rings using a thickness gauge.
- If any measurements are greater than specified, replace the piston rings.

N.B.

BEFORE REPLACING ONLY THE PISTON RINGS, ENSURE THAT THE CLEARANCE BETWEEN THE PISTON RINGS AND THE PISTON RING GROOVES, AND BETWEEN THE PISTON AND THE CYLINDER, IS AS SPECIFIED. IN ANY CASE, NEW PISTON RINGS USED IN COMBINATION WITH A USED CYLINDER MAY HAVE DIFFERENT BEDDING CONDITIONS THAN THE STANDARD.

SEALING RINGS

Name	Description	Dimensions	Initials	Quantity
Top piston ring		0.08 ÷ 0.20 mm		0.35 mm
Middle piston ring		0.05 ÷ 0.20 mm		0.30 mm
oil scraper		0.20 ÷ 0.70 mm		0.80 mm

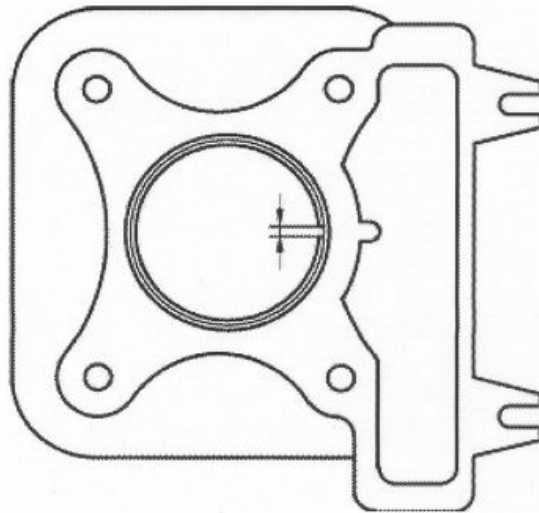

Removing the piston

- Install piston and wrist pin onto the connecting rod, aligning the piston arrow the arrow facing towards the exhaust.
- Fit the pin stop ring onto the appropriate tool.

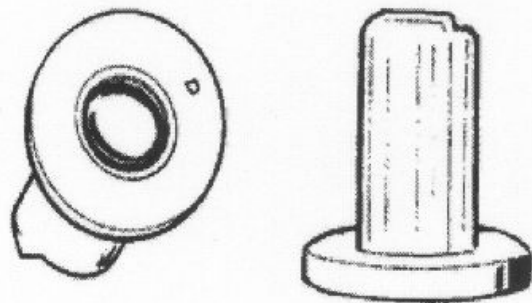

Specific tooling

020448Y Pin lock fitting tool

- With the opening in the position indicated on the tool, set the lock ring into position in the tool with the punch.
- Rest the tool on the piston paying attention that the 90° chamfered side faces upwards as indicated in the figure.
- Fit the gudgeon pin stop using the plug.

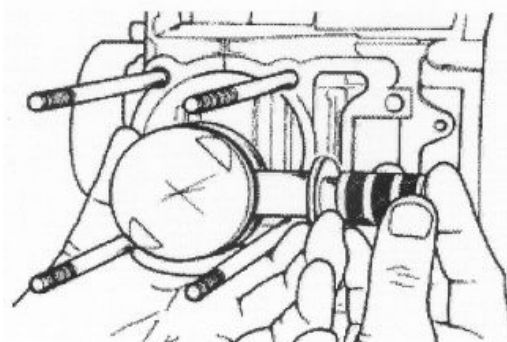

CAUTION

USING A HAMMER TO POSITION THE RINGS CAN DAMAGE THE LOCKING HOUSING.

Refitting the piston rings

- Alternately insert the three sealing rings into the cylinder, in the area where it retains its original diameter. Using the piston, insert the rings perpendicularly to the cylinder axis.
- Measure the opening, see figure, of the sealing rings using a thickness gauge.
- If any measurements are greater than specified, replace the piston rings.

N.B.

BEFORE REPLACING ONLY THE PISTON RINGS, ENSURE THAT THE CLEARANCE BETWEEN THE PISTON RINGS AND THE PISTON RING GROOVES, AND BETWEEN THE PISTON AND THE CYLINDER, IS AS SPECIFIED. IN ANY CASE, NEW PISTON RINGS USED IN COMBINATION WITH A USED CYLINDER MAY HAVE DIFFERENT BEDDING CONDITIONS THAN THE STANDARD.

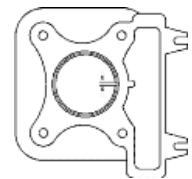

SEALING RINGS

Name	Description	Dimensions	Initials	Quantity
Top piston ring		0.08 ÷ 0.20 mm		0.35 mm
Middle piston ring		0.05 ÷ 0.20 mm		0.30 mm
oil scraper		0.20 ÷ 0.70 mm		0.80 mm

- Fit the oil scraper ring starting from the spring, taking care that the spring ends do not superimpose. Fit the two piston rings so that their gaps and that of the oil scraper ring are never aligned.
- Fit the 2nd sealing ring with the identifying letter «T» facing towards the piston crown.
- Fit the 1st sealing ring with the reference letter «T» facing towards the piston crown.
- Offset the ring gaps by 120° to each other as shown in the figure.
- Lubricate the components with engine oil.

N.B.

IN ORDER TO OBTAIN A GOOD BEDDING, THE 2 SEALING PISTON RINGS ARE MADE OF CONE SHAPED CONTACT SECTION TO THE CYLINDER. AS A RESULT IT IS IMPORTANT TO RESPECT THE FITTING INSTRUCTION TO ASSEMBLY THE RINGS WITH THE "T" MARK FACING UPWARDS.

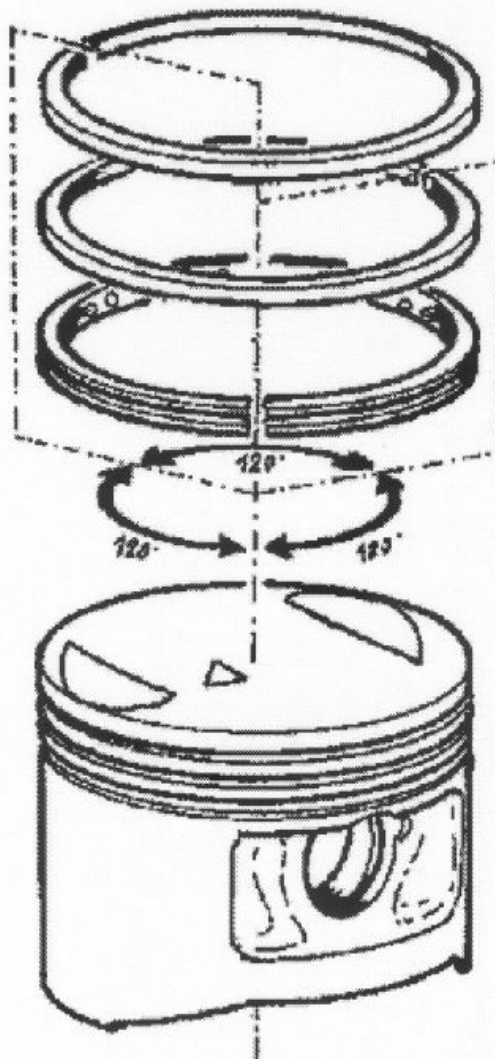

Refitting the cylinder

- Insert the cylinder base gasket.
- Fit the cylinder as shown in the figure.
- It is possible to maintain the piston out of the crankcase plane using the special tool.

N.B.

BEFORE FITTING THE CYLINDER, CAREFULLY BLOW OUT THE LUBRICATION DUCT AND OIL THE CYLINDER BARREL.

Specific tooling

020288Y Fork to assemble piston on cylinder

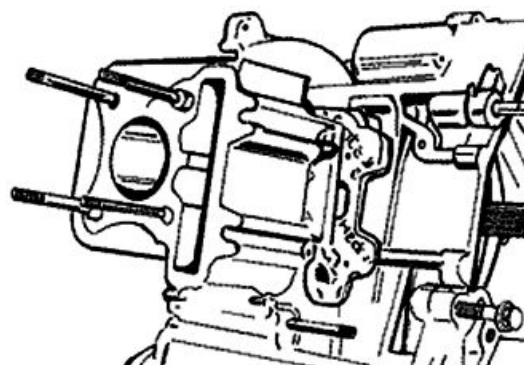

When replacing the four cylinder studs, on this engine, the head nuts must be tightened according to the procedure below.

This differs from what is specified on the vehicle's manual:

Head lock-nuts (cylinder stud replacement only) $6\div 7 \text{ N}\cdot\text{m} + 135^\circ + 90^\circ$

The 45° reduction in rotation is necessary to prevent the excessive straining of the studs.

Inspecting the cylinder head

- Using a trued bar check that the cylinder head surface is not worn or distorted.
- Check that the camshaft and rocking lever pin bearings show no signs of wear.
- Check that the cylinder head cover surface, the intake manifold and the exhaust manifold are not worn.

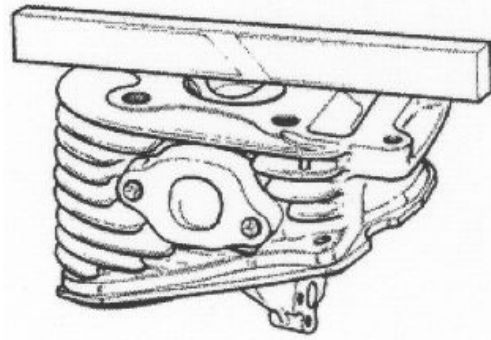

Characteristic

Maximum admitted unevenness: Head check

0.05 mm

HEAD CHECK

Specification	Desc./Quantity
Standard diameter (mm) A	$\varnothing 32.015 \div 32.025 \text{ mm}$
Standard diameter (mm) B	$\varnothing 16.0 \div 16.018$
Standard diameter (mm) C	$\varnothing 11.0 \div 11.018$

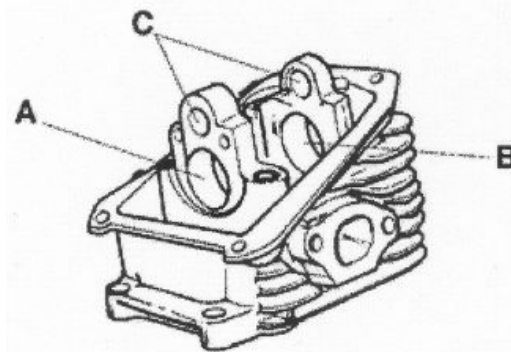

Inspecting the timing system components

- Check that the guide shoe and the tensioner shoe are not worn out.
- Ensure that the camshaft drive pulley, the chain assembly and the sprocket wheel are not worn.
- If sings of wear are found, replace the parts. if the chain, pinion or pulley are worn, replace the whole assembly.

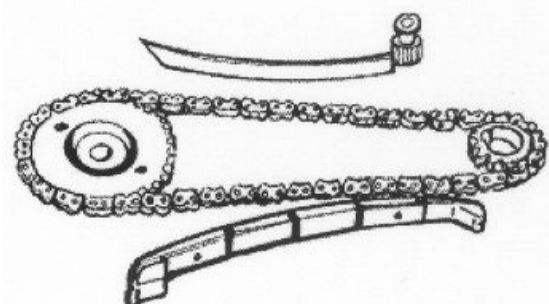

- Remove the central screw and the tensioner spring. Check that the one-way mechanism is not worn.
- Check the condition of the tensioner spring.
- If examples of wear are found, replace the whole assembly.

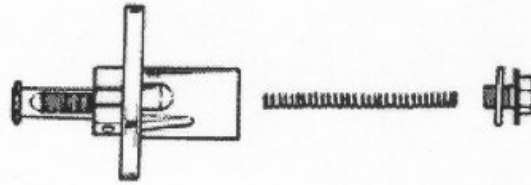

Inspecting the valve sealings

- Measure the width of the sealing surface on the valve seats.

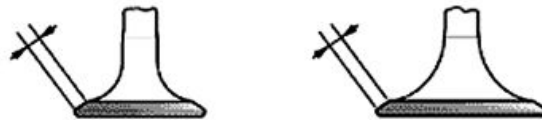

Characteristic

Sealing surface width: Intake

1.5 mm

Sealing surface width: Drainage

1.6 mm

- Insert the valves into the cylinder head.
- Test the 2 valves alternatively.
- The test is carried out by filling the manifold with petrol and checking that the head does not ooze through the valves when these are just pressed with the fingers.

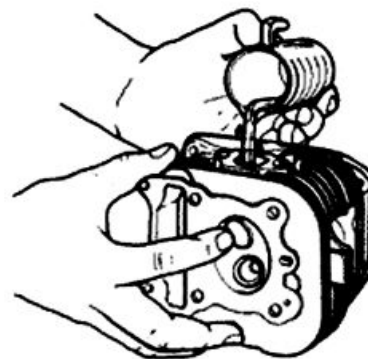

Inspecting the valve housings

- Remove any carbon formation from the valve guides.
- Measure the inside diameter of each valve guide.
- Take the measurement at three different heights in the rocker arm push direction.

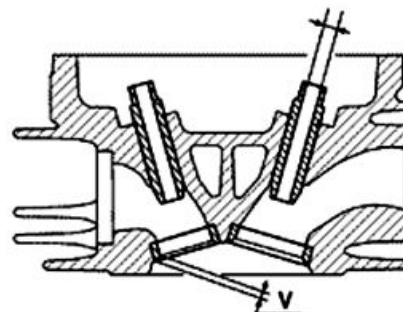

Characteristic

Discharge guide: Standard diameter

5 +0+0.012mm

Discharge guide: Wear limit

5.022 mm

Intake guide: Standard diameter

5 +0+0.012mm

Intake guide: Wear limit

5.022 mm

- If the width of the impression on the valve seat or the diameter of the valve guide exceed the specified limits, replace the cylinder head.

- Check width of the impression on the valve seat «V»

Characteristic

Wear limits:

Max. 1.6 mm.

Inspecting the valves

- Measure the diameter of the valve stems in the three positions indicated in the diagram.

- Calculate the clearance between the valve and the valve guide.

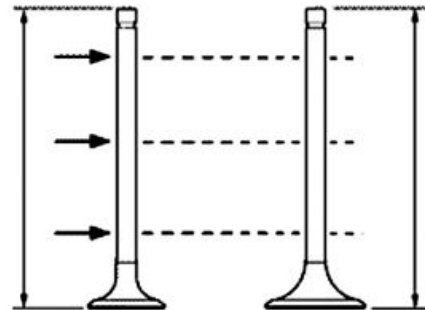

Characteristic

Minimum diameter allowed: Intake

4.970 mm

Minimum admissible diameter drainage

4.960 mm

Fitting clearance

Standard clearance: Intake 0.015 ÷ 0.042 mm

Standard clearance: drainage 0.025 ÷ 0.052 mm

- Check that there are no signs of wear on the contact surface with the articulated register terminal.

- If the sealing surface on the valves is wider than the specified limit, damaged in one or more points or curved, replace the valve with a new one.

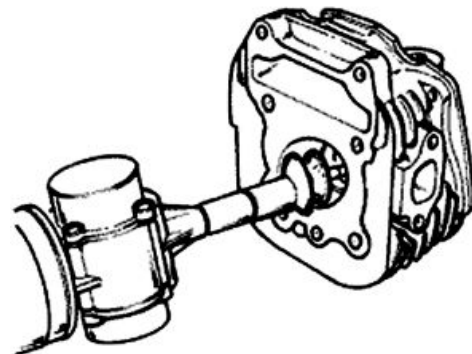

Characteristic

Valve standard length: Intake

70.1 mm

Valve standard length: drainage

69.2 mm

Fitting clearance

Max. clearance allowed: Intake 0.052 mm **Max.**

clearance allowed: drainage 0.062 mm

- If the checks above give no failures, you can use the same valves. For best sealing results, it is advisable to grind the valves. Grind the valves gently with a fine-grained lapping compound. During

grinding, keep the cylinder head in a horizontal position. This will prevent the lapping compound residues from penetrating between the valve stem/guide coupling.

CAUTION

TO AVOID SCORING THE CONTACT SURFACE, DO NOT KEEP ROTATING THE VALVE WHEN NO LAPPING COMPOUND IS LEFT. CAREFULLY WASH THE CYLINDER HEAD AND THE VALVES WITH A SUITABLE PRODUCT FOR THE TYPE OF LAPPING COMPOUND BEING USED.

Inspecting the springs and half-cones

- Check that the upper spring caps and the cotter halves show no signs of abnormal wear.

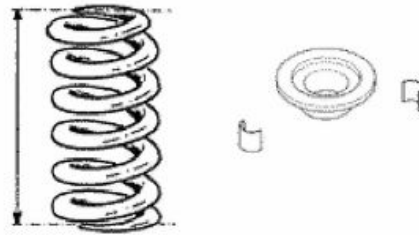

Refitting the valves

- Lubricate the valve guides with graphite grease.
- Place the lower plates of the valve spring on the head.
- Use the punch to fit the 2 sealing rings one at a time.

Specific tooling

020306Y Punch for assembling valve seal rings

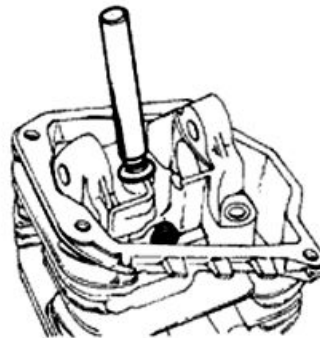

- Fit the valves, the springs and the upper plates.
- Using the appropriate tool, compress the springs and insert the cotters in their seats.

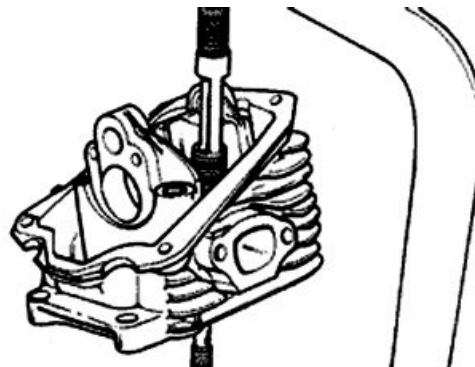

Inspecting the cam shaft

- Inspect the cam shaft for signs of abnormal wear on the cams.

Characteristic

Standard diameter - Bearing A:

$\varnothing 12 +0.002 +0.010$

Standard diameter - Bearing B:

$\varnothing 16-0.015 -0.023$ mm

Minimum diameter allowed - Bearing A:

$\varnothing 11.98$ mm

Minimum diameter allowed - Bearing B:

$\varnothing 15.96$ mm

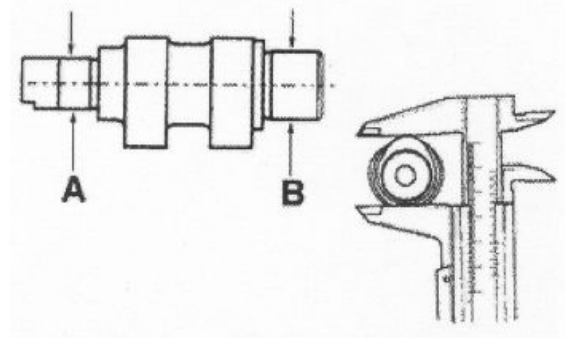

- If any of the above dimensions are outside the specified limits, or there are signs of excessive wear, replace the defective components with new ones.

N.B.

A BALL BEARING IS FITTED ON BEARING «A»; CONSEQUENTLY, BEARING «B» IS THE MOST IMPORTANT AS IT WORKS DIRECTLY ON THE HEAD ALUMINIUM

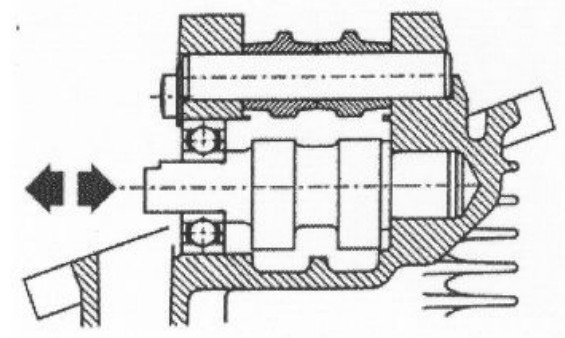

Characteristic

Standard height - Intake:

25.935 mm

Standard height - Discharge:

25.935 mm

Fitting clearance

Maximum admissible axial clearance 0.5 mm

- Check there are no signs of scoring or wear on the rocking lever bolt.

- Measure the diameter «A».

- Measure the internal diameter of each rocking lever. level «B».

Check there are no signs of wear on the pad from contact with the cam and on the jointed adjustment plate.

- In case of anomalies, replace the damaged components.

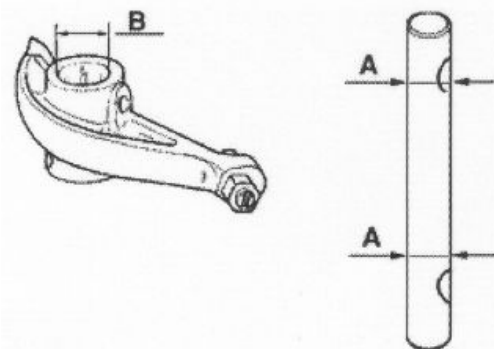

Characteristic**Minimum admissible diameter**

Ø 10.970 mm

Maximum diameter allowed:

Ø 11.030 mm

Refitting the head and timing system components

- Fix the head on a workbench.
- Screw the tool to fit the camshaft fully down on the bearing's inner track.
- Fit the camshaft fully into its seating together with the bearing with the aid of a mallet.
- Remove the tool.
- Fit the head gasket after cleaning the faying surface carefully.
- Insert the head in the cylinder stud bolts and tighten the 4 fixing nuts to the prescribed torque.

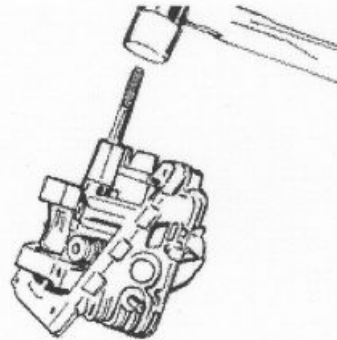
**Specific tooling****020450Y Camshaft fitting/removal tool****Locking torques (N*m)**

Head-cylinder stud bolt nuts: 6 ÷ 7 +135° +90° Nm first fitting, upon refitting tighten again at 6 ÷ 7 90° +90° Nm

- Loosen the rocking lever registers.
- Fit the pin, the intake rocking lever and the discharge rocking lever.
- Lubricate the 2 rocking levers through the holes.

N.B.

IF A BEARING SEPARATES FROM THE CAM-SHAFT, IT IS ESSENTIAL TO FIT A NEW BEARING.

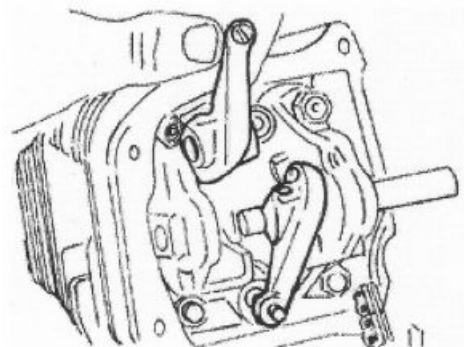

- Screw the limit screw for the pin and the camshaft with the washer indicated in the figure and tighten it to the prescribed torque.

Locking torques (N*m)

Rocking lever axle and camshaft bearing screw 3 ÷ 4 Nm

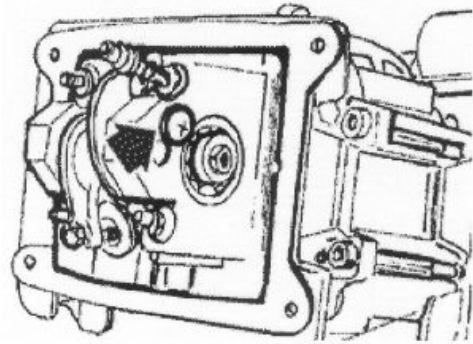

- Finish the head tightening following the procedure below: screw the four head nuts to an initial torque at two crossed passes. Afterwards tighten the nuts with 2 turns of 90° each to be done at two crossed passes.

-Finish the tightening of the head to the crankcase with the 2 side screws.

N.B.

SHOULD THE CRANKCASE OR THE CYLINDER STUD BOLTS BE REPLACED, IT IS NECESSARY TO CARRY OUT AN INITIAL TIGHTENING PLUS OTHER 3 TURNS OF 90° EACH AT 3 CROSSED PASSES

Locking torques (N*m)

Head-cylinder stud bolt nuts: 6 ÷ 7 +135° +90° Nm first fitting, upon refitting tighten again at 6 ÷ 7 90° +90° Nm Head cover screws 8 ÷ 10 Nm

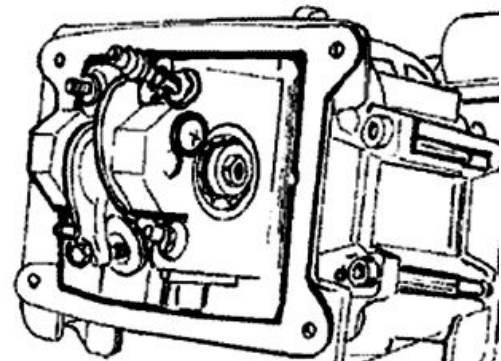

Refitting the timing chain

- Insert the timing chain pads in their corresponding seatings, the screw and the spacer as indicated in the figure.

- Tighten to the prescribed torque and check the tensioner pad moves adequately.

- Insert the timing pinion in driving shaft with the chamfered side facing the insertion (towards the main bearing).

- Loop the timing chain around the sprocket on the crankshaft.

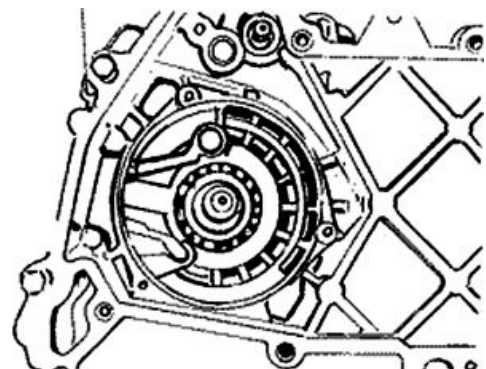

Locking torques (N*m)

Chain tightener pad screw 5 ÷ 7 Nm

- Refit the spacer on the cam shaft.
- Rotate the engine so that the piston is at top dead centre, using the reference marks on the flywheel and the crankcase.
- With this operation, insert the chain on the camshaft control pulley and make the reference notch coincide with the point on the head.
- Fit the pulley on the camshaft.
- Fit the belleville washer so that the outer rim touches the pulley.
- Bring the screw closer but without reaching its final locking point.

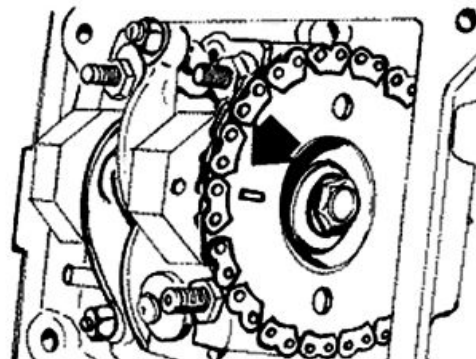
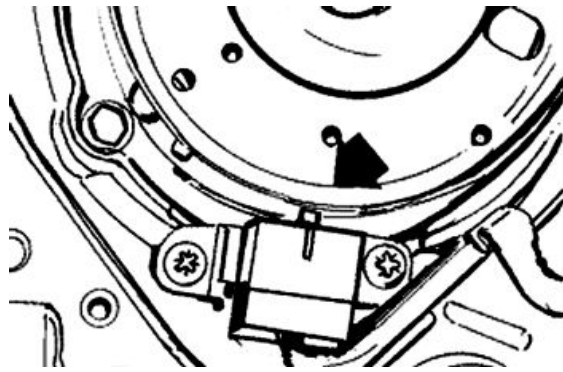

- Push the tensioner pad lightly so as to check the correct timing.
- Use the specific tool to lock the camshaft crown gear and tighten the screw.
- Adjust valve clearance.
- Replace the O-Ring on the tappet cover.
- Fit the tappet cover and lock it with the 4 fixing screws indicated in the figure.

Specific tooling

020565Y Flywheel lock calliper spanner

Locking torques (N*m)

Camshaft pulley screw 12 ÷ 14 Head cover screw 8 ÷ 10 Nm

- Set the tensioner cursor in the rest position.
- Fit the chain tensioner on the cylinder, using a new gasket, and tight the two screws to the prescribed torque.
- Insert the spring with the central screw and tighten it to the prescribed torque.
- Fit the spark plug.

Characteristic

Recommended spark plug

NGK CR 9EB - CHAMPION RG 4HC

Electric characteristic

Electrode gap

0.7 ÷ 0.8 mm

Locking torques (N*m)

Timing chain tensioner screw $8 \div 10$ Nm Timing chain tensioner central screw 5 - 6 Ignition spark plug $10 \div 15$ Nm

Refitting the rocker-arms cover

- Carry out the removal procedure but in reverse order and tighten the four fixing screws to the specified torque.

N.B.

FIT A NEW O-RING ON THE TAPPET COVER.

Locking torques (N*m)

Timing chain tensioner screws $8 \div 10$ Nm

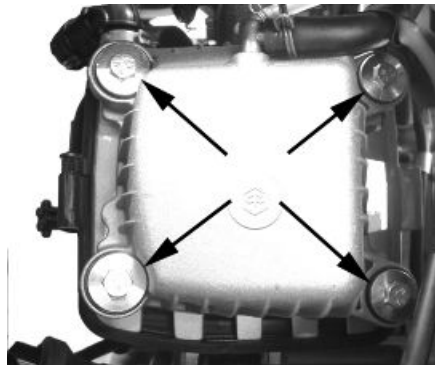

Refitting the intake manifold

- Fit the cover sealing gaskets on the head.
- Fit the 2 covers.
- Fit the inlet manifold and do up the 2 screws to the specified torque.
- Fit the carburettor on the inlet manifold and lock the clamp.
- Fit the secondary air pipe and fix it with the appropriate clamp.

N.B.

FIT THE CARBURETTOR THROUGH THE SUPPLEMENT ON THE MANIFOLD.

Locking torques (N*m)

Inlet manifold screw $7 \div 9$ Nm

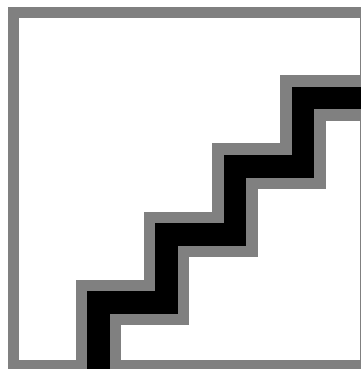

Crankcase - crankshaft

- First remove the following units:
Driving pulley Driven pulley
Final reduction greasing
Oil pump Flywheel with stator
Cylinder-piston-head unit
Starter motor with cables.

See also

[Removing the driving pulley](#)

[Removal](#)

[Removing the driven pulley](#)

[Removing the cylinder - piston assy.](#)

Removing the starter motor
Removing the stator

Splitting the crankcase halves

- Remove the ten crankshaft coupling screws.
- Separate the crankcase halves keeping the half casing driving shaft engaged on the transmission side.
- Remove the crankshaft.

CAUTION

IF YOU FAIL TO DO THIS, THE CRANKSHAFT MIGHT ACCIDENTALLY FALL.

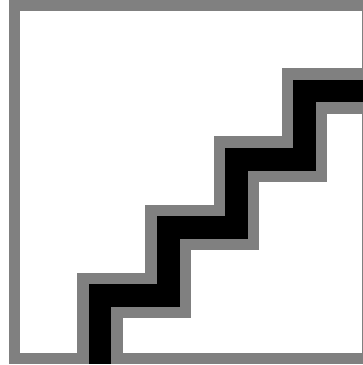

- Remove the oil guard on the flywheel side.

CAUTION

THE CENTRIFUGAL OIL FILTER IS IN THE FLYWHEEL AXLE SHAFT. CONSEQUENTLY, DO NOT WASH WITH SOLVENTS OR BLOW COMPRESSED AIR SO THAT NO IMPURITIES LEAK OUT. A CENTRIFUGAL OIL FILTER'S LIFE IS THE SAME AS THE ENGINE'S AND IS MAINTENANCE FREE.

- Check the axial clearance on the connecting rod.

Fitting clearance

Connecting rod endfloat - standard clearance 0.15 ÷ 0.30 mm
Connecting rod endfloat - standard clearance 0.5 mm

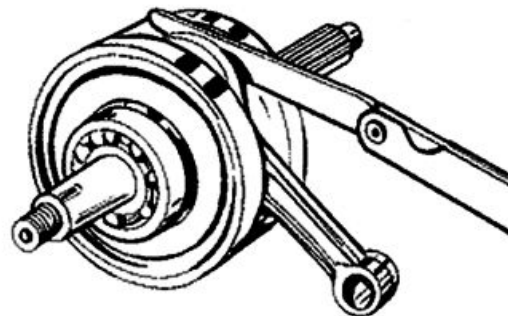

- Check the correct radial clearance of the connecting rod by holding the driving shaft with your hands and, with a dial gauge fitted to the rod small end, measuring the clearance, move the connecting rod vertically as shown in the figure.

Fitting clearance

Connecting rod radial - standard clearance 0.006 ÷ 0.018 mm
Connecting rod max. - radial clearance 0.25 mm

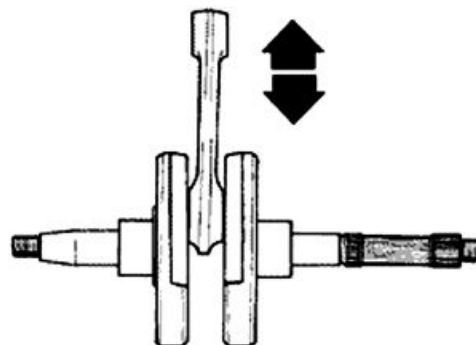

- Check that the half shaft surfaces are not scored and with the aid of a gauge check the driving shaft width as indicated in the figure.

Characteristic

Standard measure

45 mm

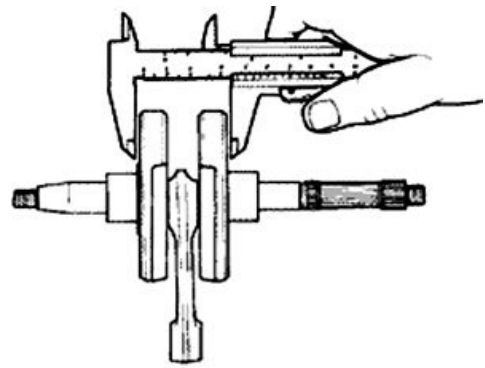

Removing the crankshaft bearings

- Remove the flywheel bearing fitted on the driving shaft using the specific tool.

Specific tooling

004499Y Camshaft bearing extractor

004499Y001 Bearing extractor bell

004499Y002 Bearing extractor screw

004499Y006 Bearing extractor ring

004499Y034 Bearing extractor part

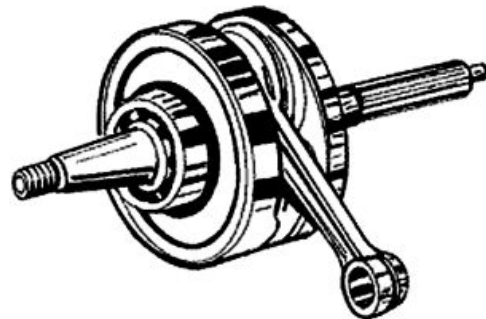

Refitting the crankshaft bearings

- Support the crankcase on a surface and place it with the driving shaft axle in a vertical position.

- Warm the crankcase at ~ 120° C with a thermal gun (and support).

- Fit the punch with guide and adaptor, place the bearing on the punch using grease (to keep it from falling).

- Insert the bearing in the crankcase; if needed, use a mallet but do so with extreme care so as not to damage the engine crankcase limit stop.

Specific tooling

020359Y 42x47-mm adaptor

020364Y 25-mm guide

020376Y Adaptor handle

020360Y Adaptor 52 x 55 mm

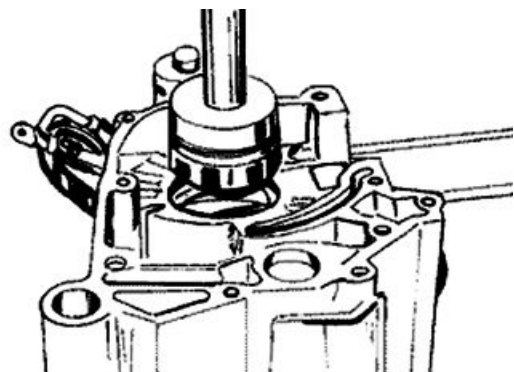

- Heat a new main bearing in an oil bath at 120°.
- Place the driving shaft on the support base and insert the bearing with the aid of an adequate piece of tube if necessary.

N.B.

USE A NEW BEARING WHEN REFITTING

WARNING

THE CENTRIFUGAL OIL FILTER IS IN THE FLY-WHEEL AXLE SHAFT. DO NOT WASH WITH SOLVENTS OR BLOW COMPRESSED AIR SO THAT NO IMPURITIES LEAK OUT.

Specific tooling

020265Y Bearing fitting base

008119Y009 Tube to assemble shafts and axles

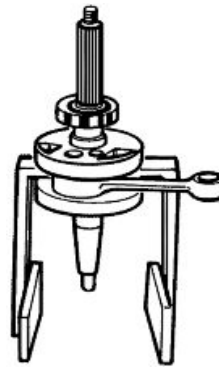

Inspecting the crankshaft alignment

To install the drive shaft on the support and to measure the misalignment in the 4 points indicated in figure.

N.B.

IF VALUES OTHER THAN THOSE ALLOWED ARE DETECTED, TRY STRAIGHTENING THE CRANKSHAFT BY INSERTING A WOODEN WEDGE BETWEEN THE HALF SHAFTS OR BY CLOSING THEM WITH A VICE AS NEEDED. IF EVEN AFTER THIS OPERATION THE VALUES ARE NOT THOSE ADMITTED, REPLACE THE CRANKSHAFT.

Characteristic

Off-line maximum admitted - A

0.15 mm

Off-line maximum admitted - B

0.02 mm

Off-line maximum admitted - C

0.02 mm

Off-line maximum admitted - D

0.10 mm

- Check that the driving shaft cone, the tab seat, the oil seal capacity, the toothed gear and the threaded tangs are in good working order.
- In case of failures, replace the driving shaft.

Specific tooling

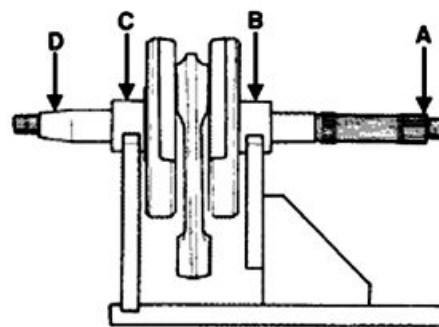

020074Y Support base for checking crankshaft alignment

Refitting the crankcase halves

- Be careful to place the two centring dowels preferably on the flywheel side half casing.
- Insert the crankshaft on the half casing on the transmission side.

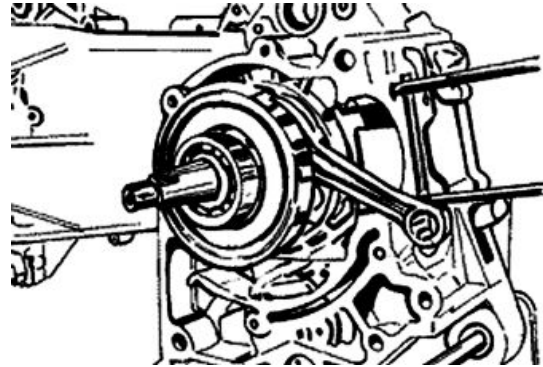

- Fit the gasket recommended for surfaces on the half casing on the transmission side after greasing the two faying surfaces carefully.
- Insert the flywheel half casing.
- Fit the 10 screws and tighten them to the prescribed torque.

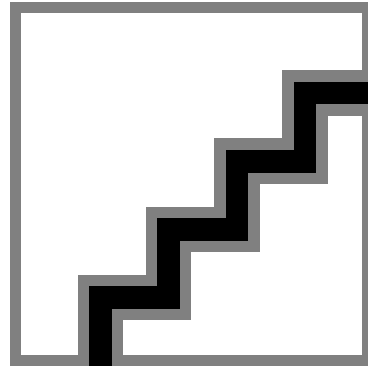

N.B.

WHEN FITTING THE HALF CASING AND THE CRANKSHAFT, TAKE CARE NOT TO DAMAGE THE SHAFT THREADED TANGS.

Recommended products

Loctite 510 Liquid sealant

Gasket

Locking torques (N*m)

Half casing joint bolts: 8 ÷ 10 Nm

- Fit a new O-Ring on the mesh oil filter and on the filling cap; lubricate the rings.
- Insert the filter on the engine and lock the cap to the prescribed torque.

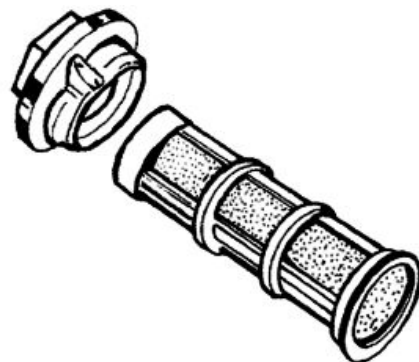
Locking torques (N*m)

Engine oil pre-filter cover: 25 ÷ 28 Nm

Lubrication

Crankshaft oil seals

Removal

- Extract the flywheel oil seal from the crankcase being careful not to damage or score the crankcase.

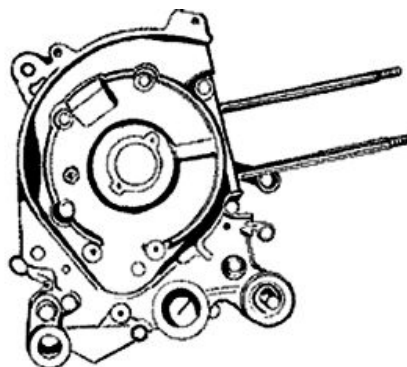

-
- Check that the chain contrast pad is not worn.
 - Otherwise, replace the pad or fit it inverted to make it work on the other side.
 - Any operation on the chain cover oil seal should be carried out placing the cover on the workbench on the covering plate side of the oil pump chain.
 - Remove the oil seal with a tube section of 30 mm in diameter (\varnothing 32 mm Max).

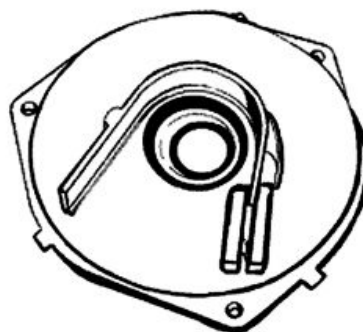

Refitting

- Apply engine oil on the oil seal and it seating on the crankcase.
- From the outside and using the specific punch, place the oil seal fully down until it reaches the bottom of the seating in the crankcase.

N.B.

FAILURE TO USE THE SPECIFIC TOOL CAN RESULT IN AN INCORRECT DEPTH POSITION AND AS A CONSEQUENCE IN INADEQUATE OIL SEALING.

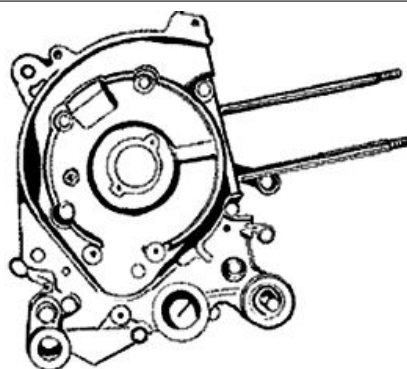

- Fit a new oil seal on the outer rim with the help of the specific tools below.
- Fit a new O-ring and lubricate it with grease.
- Install the cover on the engine crankcase, insert the three screws and place the cover in its position.
- Tighten the 3 screws to the prescribed torque.

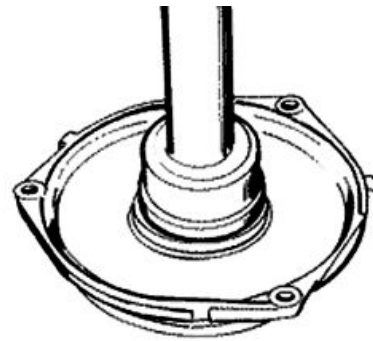

Specific tooling

020376Y Adaptor handle

020358Y 37x40-mm adaptor

Locking torques (N*m)

Timing chain/oil pump compartment cover
screws 4 ÷ 5 Nm

Oil pump

Removal

- Remove the chain compartment cover undoing the 3 fixing screws indicated in the figure.
- Take out the cover using the appropriate fusion couplings on the cover with a pair of pliers

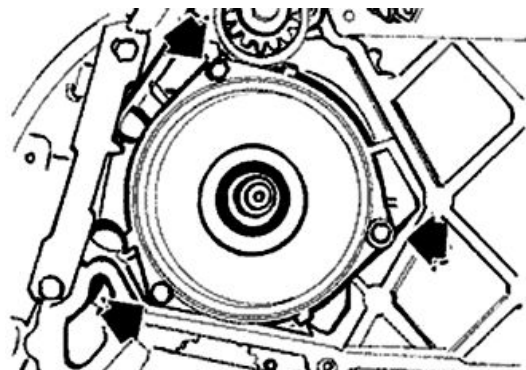

- Undo the 2 clamping screws in the figure and remove the cover over the pump control crown gear.
- Block the rotation of the oil pump control gear with a screwdriver inserted through one of its pump holes.

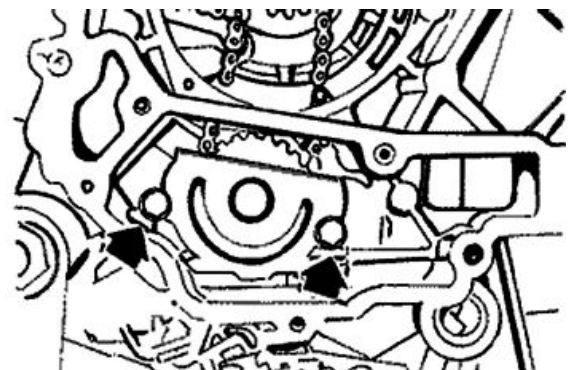

- Remove the central screw and the belleville washer
- Remove the chain with the crown gear.
- Remove the pinion of the crankshaft control.
- Remove the oil pump by undoing the 2 screws indicated in the figure.
- Remove the oil pump seal.

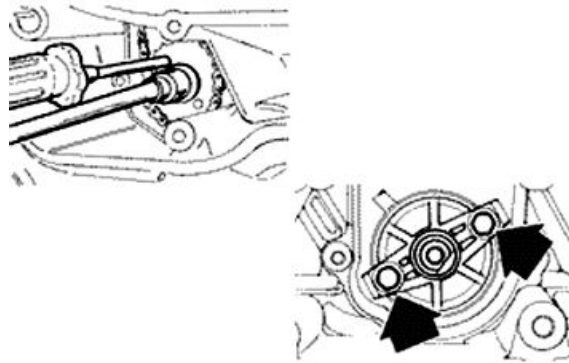

IT IS ADVISABLE TO MARK THE CHAIN IN ORDER TO ENSURE THAT THE INITIAL DIRECTION OF ROTATION IS MAINTAINED.

Inspection

- Remove the two screws and the oil pump cover.
- Remove the clip retaining the innermost rotor.
- Remove and wash the rotors thoroughly with a degreasing solvent and compressed air.
- Reassemble the rotors in the pump body, keeping the two reference marks visible. Replace the clip.



- Measure distance between rotors (inner rotor/ outer rotor) with a thickness gauge in the position shown in the picture.

Characteristic

Admissible maximum clearance 1

0.15 mm

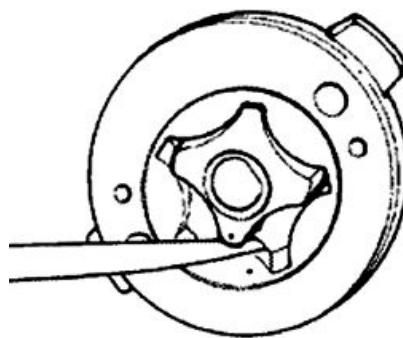

Measure the distance between the outer rotor and the pump body (see figure).

Characteristic

Admissible maximum clearance 2

0.20 mm

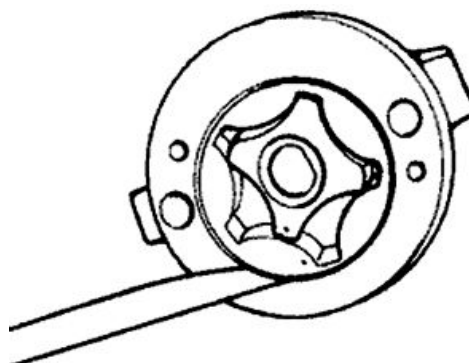

- Check the axial clearance of the rotors using a trued bar as reference as shown in the figure.

N.B.

MAKE SURE THE TRUED BAR IS POSITIONED PROPERLY ON THE TWO POINTS ON THE PUMP BODY.

Characteristic

Admissible maximum clearance 3

0.09 mm

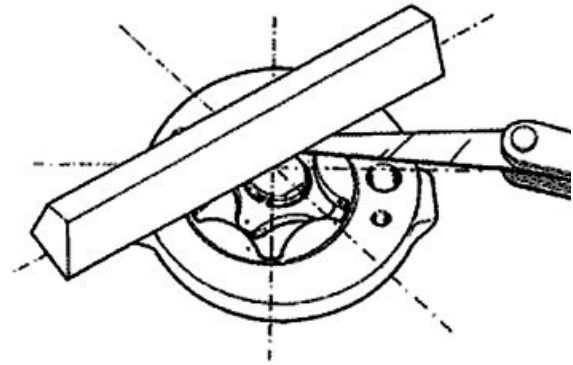

Refitting

- Check there are no signs of wear on the oil pump shaft or body.
- Check there are no signs of scoring or wear on the oil pump cover.
- If you detect non-conforming measurements or scoring, replace the faulty parts or the assembly.
- Fit the cover on the pump being careful to align the holes (2 on the cover and 2 on the pump body) fixing the oil pump on the crankcase.
- Fit the oil pump on the crankcase by tightening the two screws to the prescribed torque.
- Fit the pulley on the pump, the central screw to the specified torque and the belleville washer.
- Check that there is no seizing and/or friction during the pulley rotation.

N.B.

FIT THE BELLEVILLE WASHER SO THAT ITS OUTER (CURVED) RIM TOUCHES THE PULLEY.

Locking torques (N*m)

Central screw 12 ÷ 14 Nm Cover screws 0.7 ÷ 0.9 Nm Oil pump screws 5 - 6



Removing the oil sump

- Remove the oil filling cap, the transmission cover, the complete driving pulley assembly with belt and pinion.
- Unscrew the oil drainage cap «A» shown in the figure and drain out all the oil from the sump.
- Remove the 6 screws indicated in the figure.

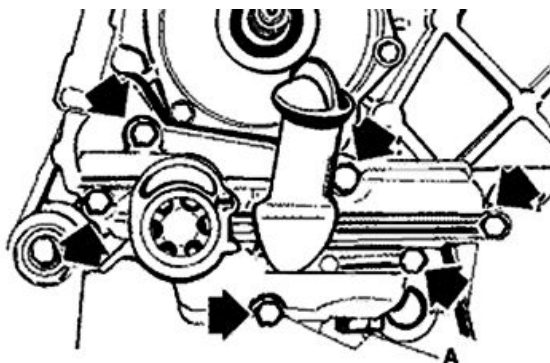

Refitting the oil sump

- Clean and grease the faying surfaces.
- Apply LOCTITE 510 on the sump surface and tighten the 6 fixing screws to the specified torque.
- Refit the driving pulley assembly, the belt, the pinion and the transmission cover.

WHEN TESTING THE LUBRICATION SYSTEM, REFER TO THE "CRANKCASE AND CRANK-SHAFT" CHAPTER, REGARDING LUBRICATION OF THE CRANKSHAFT AND CONNECTING ROD

Locking torques (N*m)

Oil sump screws 8 ÷ 10 Nm

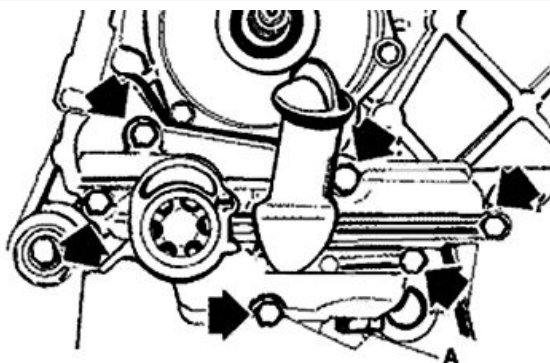

Fuel supply

- Disconnect the fuel supply and the suction taking pipe from the carburettor.
- Check that there are no fuel leaks between the two tubes.
- Close the fuel outlet pipe.
- By means of the MITIVAC pump apply 0.1 bar of suction to the tap.
- Make sure that the suction is kept stable and that there are no fuel leaks.
- Reconnect the suction pipe to the manifold.
- Position the fuel pipe with the outlet at the point of the tap.

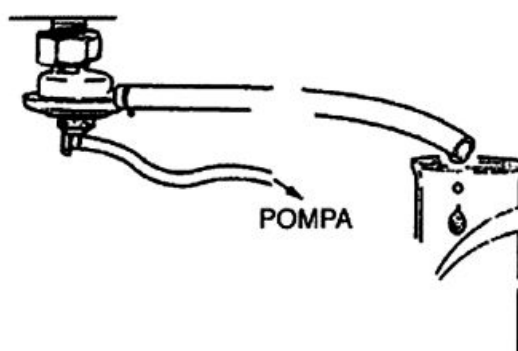

- Turn the engine by using the starter for five seconds with the carburettor at minimum.
- Take up the fuel by means of a graded burette.

N.B.

THE MEASUREMENT MAY BE FALSIFIED BY THE INCORRECT NUMBER OF REVS OR BY THE WRONG POSITION OF THE TUBE.. IN THIS CASE, THE TENDENCY IS TO OBTAIN A REDUCED FUEL FLOW RATE. THE SUCTION OUTLET ON THE MANIFOLD HAS A SECTION INTENTIONALLY REDUCED FOR THE PURPOSE OF ENHANCING THE SUCTION PULSATION AND THEREBY GUARANTEE A CONSTANT TAP FLOW RATE.

Specific tooling

020329Y MityVac vacuum-operated pump

Characteristic

Minimum flow rate

20 cc

- Completely empty the gas tank.
- Remove the petrol delivery tube and the suction tube.
- Loosen the clip and remove the tap.
- Clean the tank and the filter of the tap with a specific solvent.
- Refit the tap making sure that there is an O-Ring.
- Turn the tap to the direction it had before it was removed and block the clip.

N.B.

THE FILTER CAN BE UNSCREWED FROM THE COCK TO FACILITATE CLEANING.

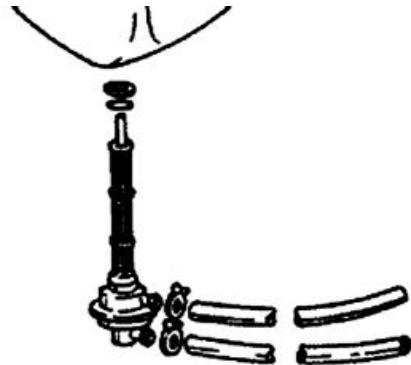

Removing the carburettor

- To detach the carburettor from the engine, remove the two clamps anchoring the carburettor to the inlet manifold and the air intake coupling to the filter.
- Remove the fuel supply pipe.
- Disconnect the starter connection.
- Detach the accelerator cable with the sheath that connects the plate and the support.
- Remove the carburettor.

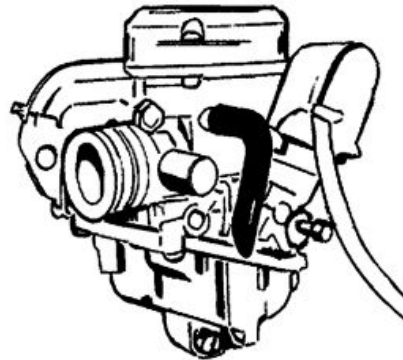

- Remove the protection, the bracket and the starter undoing the screw shown in the figure.

CAUTION

THE CARBURETTOR FEATURES AN ANTI-VIBRATION RUBBER BUFFER FITTED ON THE LOWER SUPPLEMENT OF THE ACCELERATING PUMP BODY. UPON REFITTING THE CARBURETTOR ON THE ENGINE, MAKE SURE THIS BUFFER IS PRESENT SO THAT THE PETROL IN THE TANK DOES NOT EMULSIFY.

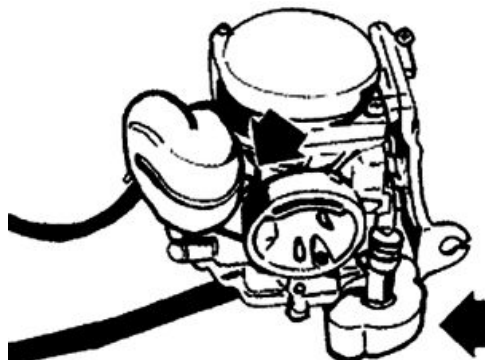

- Remove the 2 fixing screws indicated in the figure, the vacuum chamber cover and the spring.
- Remove the vacuum valve together with the diaphragm; the pin, the spring and its plastic guide.

WARNING

DURING THE REMOVAL OF THE COVER TAKE SPECIAL CARE NOT TO RELEASE THE SPRING ACCIDENTALLY.

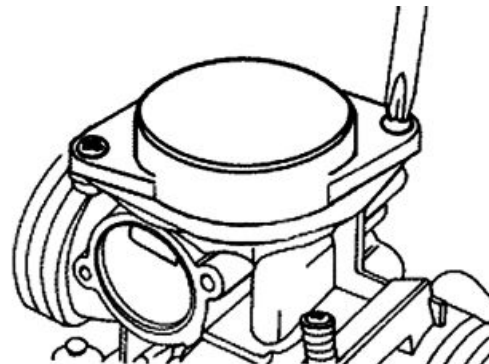

- Remove the 3 fixing screws and the tank with the gasket.

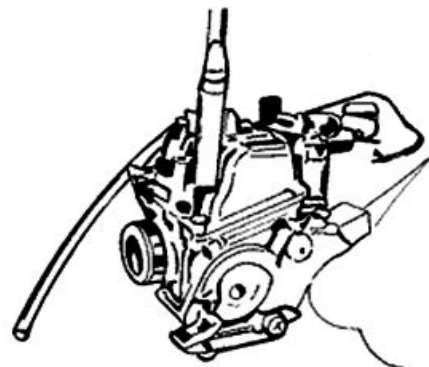

-
- Remove the tank components following the procedure below.
 - Undo the 2 screws fixing the intake pump diaphragm cover.

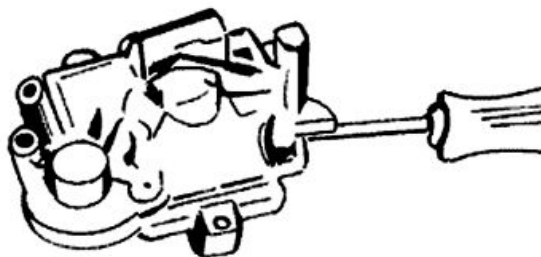

-
- Remove the cover being careful with the spring below, then remove the spring, take out the rubber protection and the diaphragm together with the pipe O-Ring.

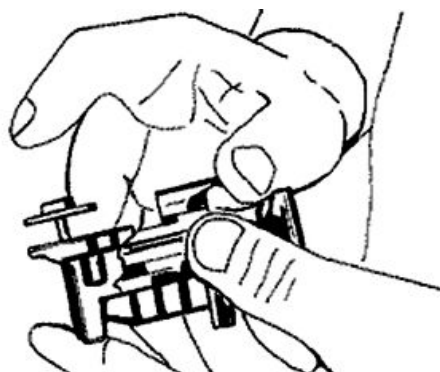

-
- Remove the accelerating pump jet together with the ball spring.

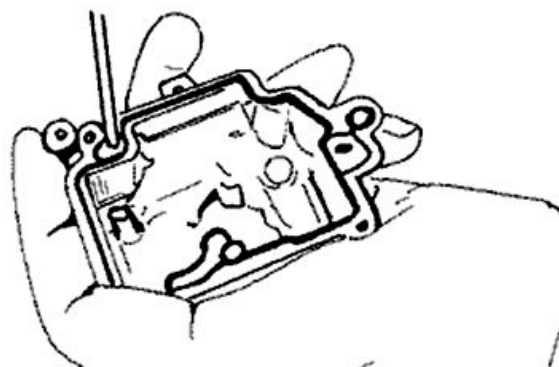

-
- Remove the screw indicated in the figure fixing the float pin.
 - Remove the float and the plunger.



-
- Remove the maximum nozzle.
 - Remove diffuser.

-Remove the minimum nozzle.

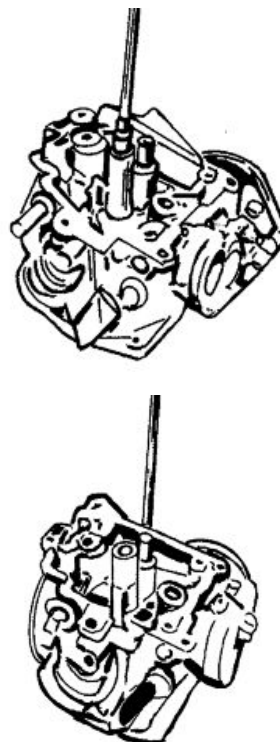

- Remove the sprayer tilting the carburettor body.

N.B.

THIS OPERATION IS NECESSARY TO AVOID LOSING SPRAYER PARTS WHEN CLEANING THE CARBURETTOR BODY. IF THE SPRAYER IS FORCED IN ITS HOUSING DO NOT ATTEMPT TO REMOVE IT AS THIS WILL ONLY DAMAGE IT.

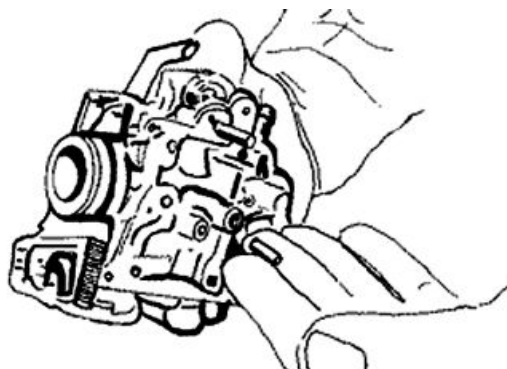

- Remove the idle flow screw with the O-ring and the spring.

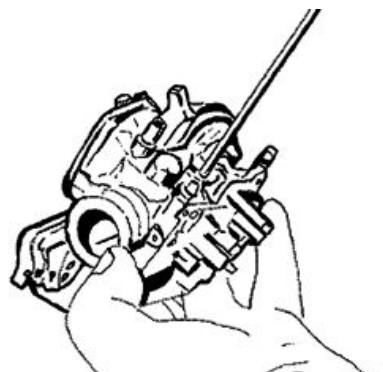

CAUTION

DO NOT ATTEMPT REMOVING PARTS EMBEDDED IN THE CARBURETTOR BODY SUCH AS: FUEL SUPPLY PIPE, PIN SEATING, STARTER NOZZLE, THROTTLE VALVE CONTROL VALVE SHAFT. DO NOT REMOVE THROTTLE-SHAFT CONNECTION SCREWS. THE FIXING SCREWS ARE CAULKED AFTER THE ASSEMBLY AND THEIR REMOVAL DAMAGES THE SHAFT.

Refitting the carburettor

- Before refitting, wash the carburettor body accurately with a degreasing solvent and compressed air.
- Pay special attention to the fuel supply pipe and the plunger seat.

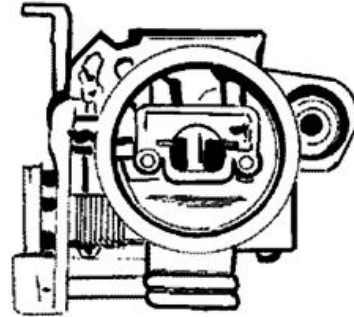

- For the minimum circuit, make sure the following points are properly cleaned: air gauging, outlet section controlled by the flow screw, progression holes near the throttle valve.

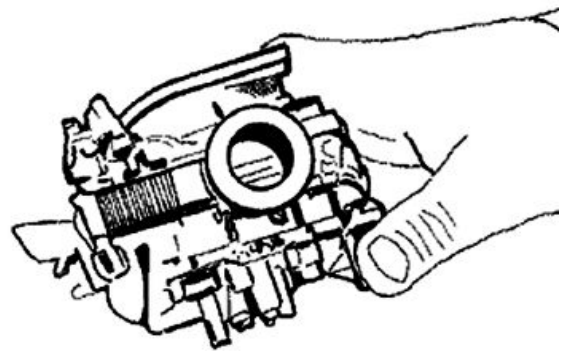

- For the starter circuit, blow the connection pipe properly with the jet. This is necessary because the nozzle support hides other inaccessible internal calibrations.

- Blow the intake nozzle properly.

The acceleration nozzle outlet is extremely small and is oriented to the throttle valve.

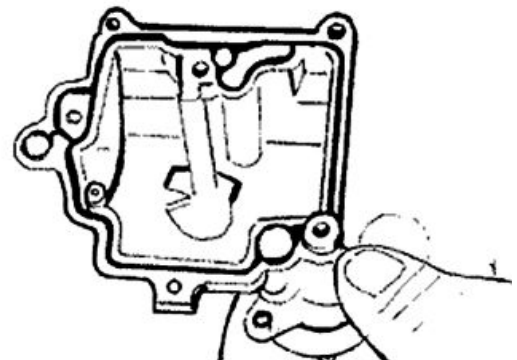

- Check that the carburettor body has the closing ball for the idle circuit pipe.
- Check that the coupling surfaces, the tank and the diaphragm are not dented.
- Check that the depression valve housing pipe is not scratched.
- Check that the throttle valve and the shaft do not show abnormal wear.
- Check that the plunger seat does not show abnormal wear.
- Replace the carburettor in case of irregularities.

N.B.

TO AVOID DAMAGES, DO NOT INTRODUCE METAL OBJECTS IN THE ADJUSTED SECTIONS.

- Wash and blow the minimum nozzle properly and reassemble it.



- Accurately wash and blow the components of the maximum circuit, the sprayer, the diffuser and the nozzle.
- Introduce the sprayer in the carburettor body with the bigger cylindric part directed to the diffuser.
- Fit the diffuser.
- Assemble the maximum nozzle.

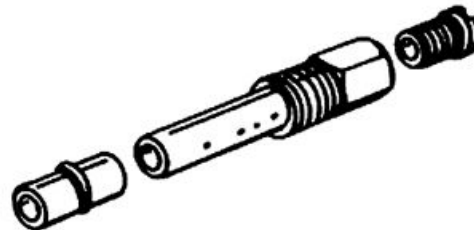

- Check that the tapered pin does not show signs of wear on the sealing surfaces of the shock absorber pin and the return clamp.
- Replace the rod if worn out.
- Check that the float is not worn on the pin housing or on the contact plate with the rod and that there are no fuel infiltrations.
- Replace it in case of anomalies.
- Fit the float together with the pin and rod in its position and lock it with its screw.

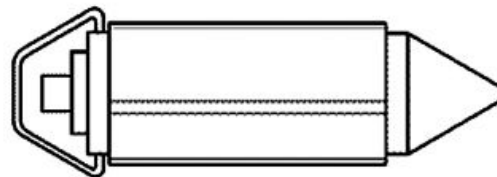

N.B.

INTRODUCE THE RETURN SPRING ON THE FLOAT PLATE ADEQUATELY

- Insert the ball in the corresponding accelerating pump.
- Fit the spring.
- Fit the accelerating pump nozzle.

WARNING

WHEN REFITTING, PAY SPECIAL ATTENTION TO THE COMPONENTS AS THEY ARE SMALL.

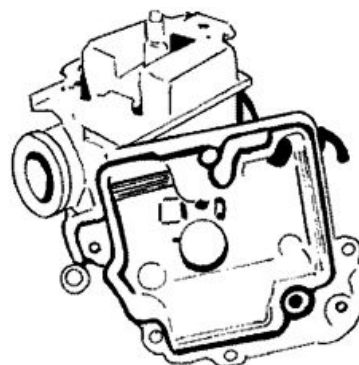

- Check the diaphragm is in good conditions and remove the remaining components of the accelerating pump following these steps:
- Insert the O-Ring in the pipe.
- Insert the diaphragm together with the pin and its spring.

N.B.

REPLACE THE DIAPHRAGM IF THERE ARE SIGNS OF UNDULATIONS, CRACKS OR HARDENING.

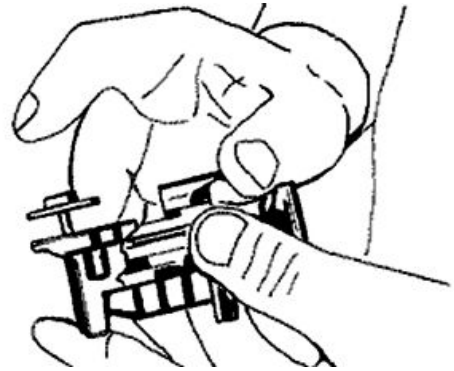

- Fit the accelerating pump diaphragm cover and tighten the 2 fixing screws making sure the spring below is correctly positioned.
- Fit the rubber bellows protecting the pin in the upper part of the accelerating pump.

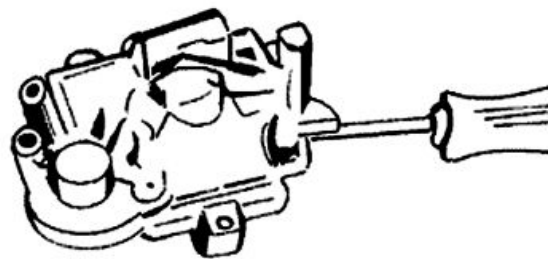

Level check

- Tilt the carburettor so that the needle valve at the fuel supply is closed and the float weight does not affect it.
- Check that the diaphragm closing line and the float central line are parallel as shown in the figure.

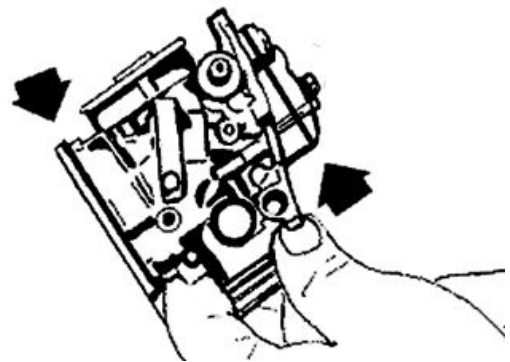

- Blow air in to the tank and then assembly it and its gasket on the carburettor body with the 3 fixing screws.

N.B.

-ALWAYS USE NEW RINGS AND GASKETS FOR REFITTING.

WARNING

THE SCREW IN THE TANK BOTTOM IS A BLEEDING ONE AND CONSEQUENTLY IT ONLY REQUIRES CLEANING.

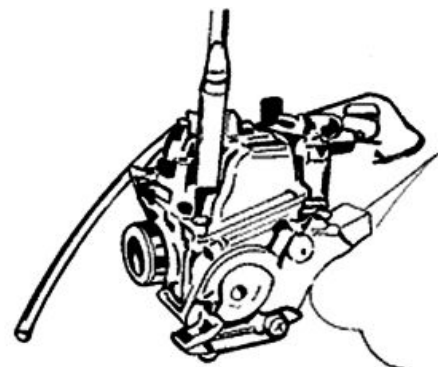

- Insert the diaphragm into the throttle valve.
- Insert the tapered pin together with the plastic support and the contrast spring into the throttle valve.

N.B.

PLACE THE SPRING PLASTIC SUPPORT WITH ITS TEETH FACING THE INNER SIDE OF THE MEMBRANE TO BE ABLE TO FIT THE LOWER END OF THE THROTTLE VALVE SPRING.

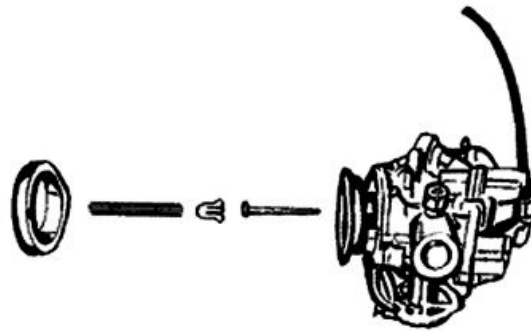

- Fit the vacuum chamber cover with the 2 fixing screws paying special attention to the spring.

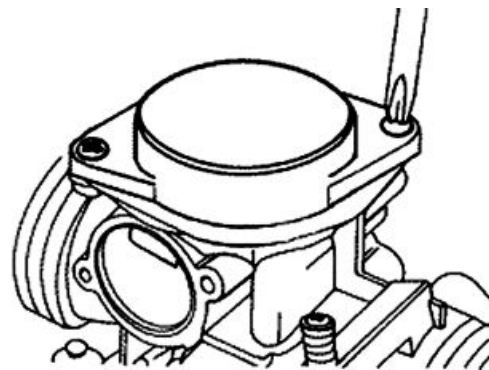

Inspecting the automatic choke device

- Ensure the automatic choke piston is not scratched or oxidised.
- Ensure the piston is free to slide within its housing.
- Check the piston O-ring is not deformed.
- The choke must be engaged as a function of the ambient temperature.
- Measure the piston projection, as shown in the figure, and check the corresponding value.
- Ensure the choke is settled to the ambient temperature.

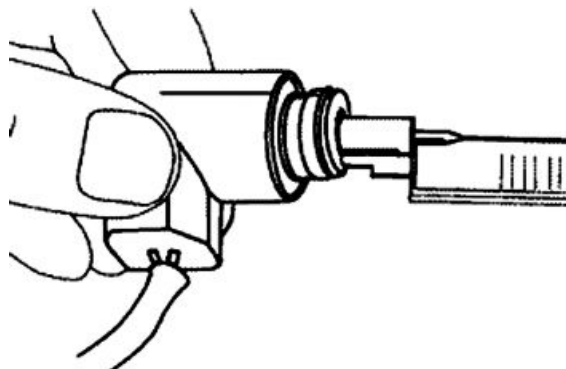
**Characteristic****Projection value**

11,5 mm

ambient temperature

24° C

- The choke device must disengage progressively through electric heating.
- Check the choke resistance when this has settled to ambient temperature.



Characteristic ambient temperature

24° C

Electric characteristic Automatic choke resistance

20 Ω ± 5 %

- Use battery to power the automatic starter and check that piston protrudes as much as possible.
- The correct warm up time depends on the ambient temperature.
- If protrusion, resistance or timing values are different from the ones prescribed, replace the starter.

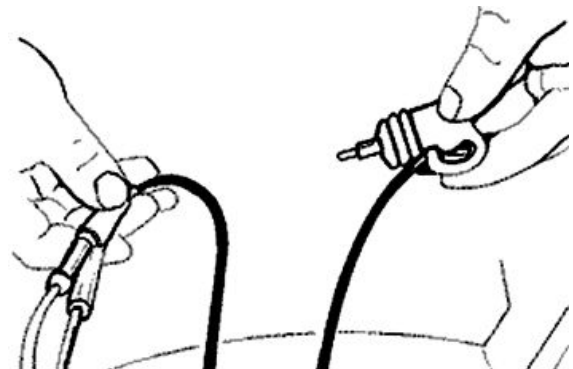

Characteristic Battery

12V-9Ah

max. protrusion

15 mm

max. time

15 min

- Fit the starter, the support bracket and the protection with the screw indicated in the figure.

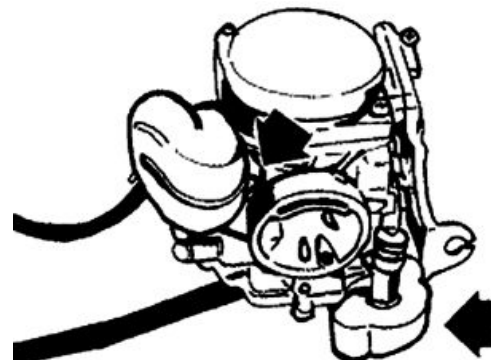

- Insert rubber pipes for tank ventilation.
- Insert the O-Ring, the washer, the spring and the idle flow screw in their seatings.

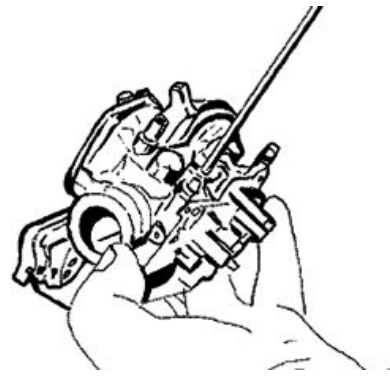

- Refit the carburettor on the engine and connect again the accelerator cable with the sheath and the support plate and the electrical connection of the starter.
- Reconnect the fuel supply pipe and tighten the 2 clamping screw fixing the carburettor to the inlet manifold and the air inlet coupling to the filter.

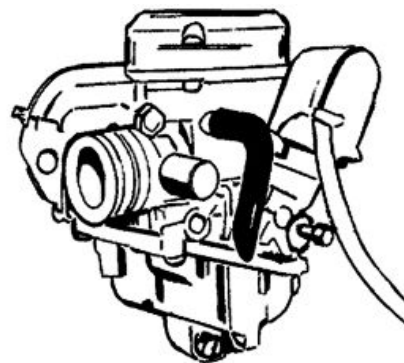

Adjusting the idle

- The engine does not require frequent idle speed adjustments, but it is essential to strictly follow certain rules when adjusting the idle speed.
- Before adjusting the carburettor make sure to respect requirements on lubrication, valve clearance, and complying timing; spark plug should be in optimum conditions, air filter clean and sealed, and the exhaust system tight.

- Warm up the engine by running it at least 10 minutes at a speed as close as possible to the maximum one.
- Connect the vehicle to the exhaust fumes analyser inserting the probe into a sealed extension pipe placed at the muffler exit end.

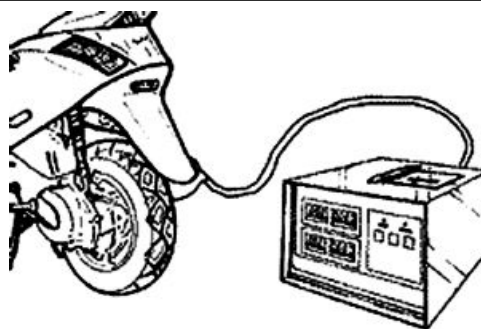

N.B.

THE EXTENSION TUBE IS INDISPENSABLE SO AS NOT TO SEND POLLUTED EXHAUST FUMES TO THE AMBIENT OXYGEN. IT IS ESSENTIAL TO USE AN EXHAUST FUMES ANALYSER PREVIOUSLY HEATED AND PREPARED TO GUARANTEE THE RESET OF THE READING OF GASES AND THE CORRECT GAS CAPACITY. FAILURE TO RESPECT THESE REGULATIONS RESULTS IN INACCURATE READINGS.

Characteristic**Pipe ideal length**

40 ÷ 50 cm

- Connect the tester thermometer to the sump, using a cover with oil expressly prepared for probes.
- Start the engine and before adjusting the idle speed, make sure that the oil temperature is between 70÷80 °C.

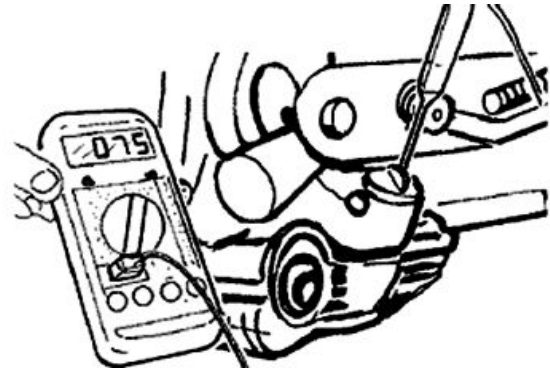
**Specific tooling**

020331Y Digital multimeter

- Using the rpm indicator in the analyser or a separate one, adjust the idle screw.

N.B.

THE WASTED SPARK IGNITION SYSTEM OFFERS REMARKABLE POWER. READINGS MAY NOT BE ACCURATE IF INADEQUATE RPM INDICATORS ARE USED.

Specific tooling

020332Y Digital rev counter

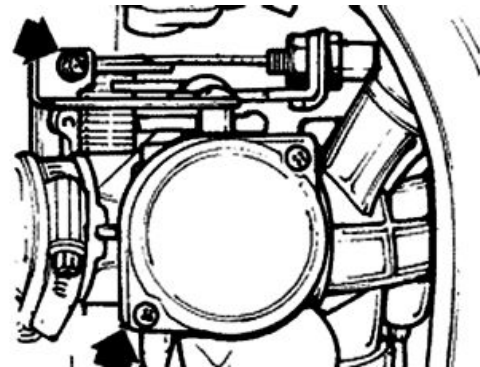
**Characteristic****Idle speed**

about 1900/2000 rpm

- Adjust the flow screw until a percentage of carbon monoxide (CO) is obtained. When the screw is loosened the CO value rises (rich mix). Tightening the screw decreases the CO (lean mix).
- If the adjustment of the flow screw causes a rpm increase readjust the revs again and if necessary, the flow screw to reach stable values.

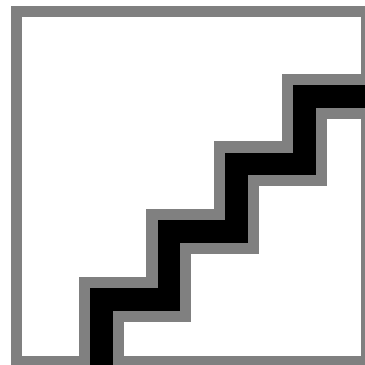
**Characteristic****CO**

2.5 ± 0.5%

- When the oil temperature, the numbers of revs and the percentage of carbon monoxide are respected the idle carburetion is considered correct.
- Further information can be drawn from the analyser:
 - carbon dioxide percentages (CO₂), the percentage of carbon dioxide has an inverted course compared to the percentage of (CO), values over 13% are considered correct.
 - Non complying values indicate lack of tightness in the exhaust system.

- Unburned hydrocarbons (HC) are measured in parts per million (PPM). The HC value decreases while the rpm increases; with the engine at idle it is normal to obtain 200 ÷ 400 PPM, these emission values are deemed normal for an engine with a diagram of timing for motorcycles. Higher values can cause loss of engine blows as the mixture is too lean (low CO), ignition failure or, incorrect timing or a clogged or unsealed exhaust valve.

If it is difficult to adjust CO values, check accurately:

- That the automatic starter is efficient.
 - That the tapered pin-housing is efficient
 - Tank level adjustments
-

INDEX OF TOPICS

SSUSPENSIONS

SUSP

Front

Removing the front wheel

- Remove the five Allen screws that fix the wheel to the hub.

N.B.

BEFORE REMOVING THE WHEEL HUB, REMOVE THE BRAKE CALLIPER.

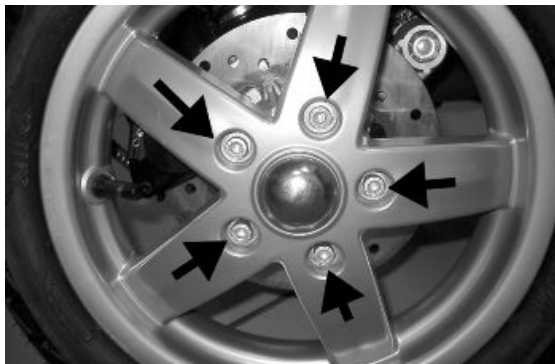

Front wheel hub overhaul

- Remove the ball bearing seeger ring indicated in the photograph



Extract the ball bearing using the specific tool

Specific tooling

001467Y014 Pliers to extract \varnothing 15-mm bearings

001467Y017 Bell for bearings, outside \varnothing 39 mm



- Remove the oil seal on the roller bearing side using a screwdriver.



- Remove the roller bearing using the specific tool

Specific tooling

020376Y Adaptor handle

020456Y Ø 24 mm adaptor

020363Y 20 mm guide



- Heat the roller bearing seat with a heat gun
- Use the specific tool to introduce and push the bearing until it stops, with the shielded side facing out
- Refit the ball bearing locking seeger ring

Specific tooling

020151Y Air heater

020376Y Adaptor handle

020359Y 42x47-mm adaptor

020412Y 15 mm guide



- Use the specific tool to fit and push the roller casing until it stops
- Refit the oil seal on the roller bearing side
- Lubricate the area between the roller bearing and the ball bearing

Specific tooling

020038Y Punch

Recommended products

AGIP GREASE MU3 Grease for odometer transmission gear case



Soap-based lithium grease with NLGI 3; ISO-L-XBCHA3, DIN K3K-20

Refitting the front wheel

- When refitting, tighten the 5 screws to the specified torque

Locking torques (N*m)

Nut tightening torque 20 to 25 N•m

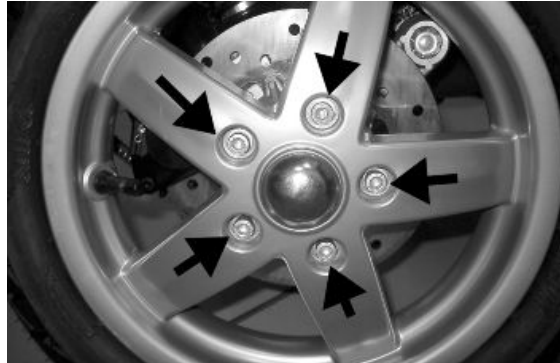

Handlebar

Removal

Remove the handlebar cover before carrying out this operation,.

- After removing the transmissions and disconnecting the electrical terminals, remove the terminal fixing the handlebar to the steering.
- Check all components and replace faulty parts.

N.B.

IF THE HANDLEBAR IS BEING REMOVED TO REMOVE THE STEERING, TILT THE HANDLEBAR FORWARD TO AVOIDING DAMAGING THE TRANSMISSIONS.

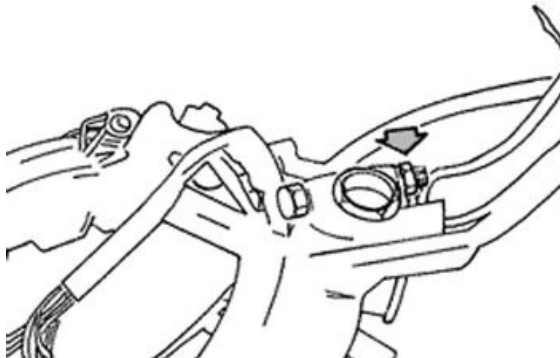

Refitting

Carry out the operations in the reverse order to the removal, observing the prescribed tightening torque.

Locking torques (N*m)

Handlebar lock nut 45 ÷ 50

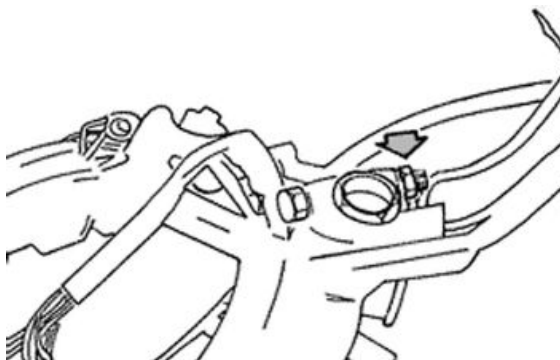

Steering column

Removal

After removing the upper seat, lean the vehicle on one side and extract the steering tube completely from the fork.

Specific tooling

020055Y Wrench for steering tube ring nut



Overhaul

-The front suspension service operation is useful to replace the connecting parts between the steering tube and the swinging hub of the front wheel holder, provided that the steering tube and the wheel holder hub are in excellent conditions.

- Press and remove the wedging washer with the help of a pointed end.
- For the second washer, repeat the operation using the punch on the side opposite to the one shown in the figure.

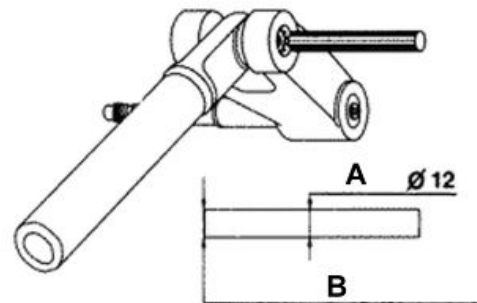

A = Ø12 Punch

B = Sharp-edged end

- Use the specific tool, fitted with part 1*, and operate the handgrip until the pin and the Nadella are simultaneously ejected in the direction opposite the tool thrusting force.

- To eject the second Nadella, use the tool fitted with part 2* instead of part 1, on the side opposite the one shown in the figure.

* Supplied with the tool

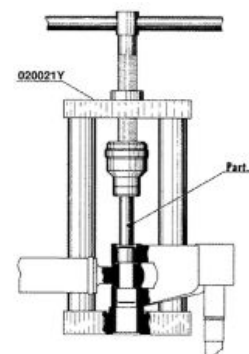

Specific tooling

020021Y Front suspension service tool

- Use the tool fitted with part 20* and part 21* on its stem as shown in the figure.
- Push the two roller casings with the handgrip until their bottoms make contact with the pin end.

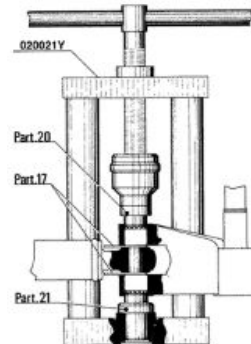

- Fit both dust guard rings «C» on the swinging hub as shown in the detail drawing «A».
- Connect the swinging hub to the steering tube with the guide pin, part 5*.
- Use the specific tool fitted with part 3* on its stem and with part 4 at the bottom of the tool.
- Insert the previously greased pin on the swinging hub and with the tool handgrip, move part 3 until it stops on the steering tube.
- After fitting the pin, insert the two spacers, part 17*, slightly hitting with the mallet.

* Supplied with the tool

Specific tooling

020021Y Front suspension service tool

Recommended products

AGIP GREASE PV2 Grease for control levers on the engine

White anhydrous-calcium based grease to protect roller bearings; temperature range between -20 ° C and +120 °C; NLGI 2; ISO-L-XBCIB2

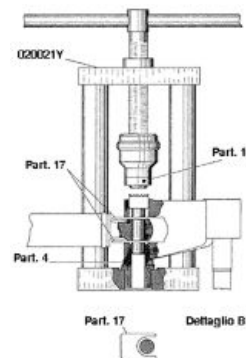
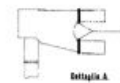
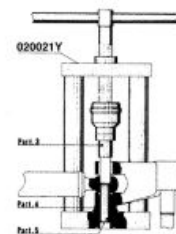

- Lubricate the sealing rings with mineral oil and half-fill the roller casings with grease.
- Insert the seal ring on the pin and the roller bushing with wedging washers at the same time.
- Remove the specific tool, then the part 5 (guiding) partially ejected in the previous assembly stage; leave part 4* always fitted.
- Replace part 3 with part 16* on the stem.
- Push, from the handgrip, the wedging washer - roller casing - seal ring unit, placing part 16 until it stops on the swinging hub
- Repeat the operation described above using the tool fitted with part 16 and part 22* instead of part 4 on the stem, on the side opposite the one shown in the figure to refit the second wedging washer - roller casing - sealing ring unit.

* Supplied with the tool

Specific tooling

020021Y Front suspension service tool

Recommended products

AGIP GREASE PV2 Grease for control levers on the engine

White anhydrous-calcium based grease to protect roller bearings; temperature range between -20 ° C and +120 °C; NLGI 2; ISO-L-XBCIB2

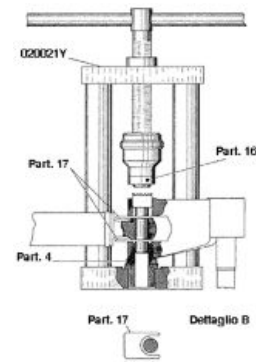

Use the tool fitted with parts 3 and 4, as indicated to fit the pin, and press operating the handgrip, until wedging the washers on the swinging hub.

- Remove the spacers, part 17, fill with grease the area between the steering tube and the swinging hub, and place the dust guard rings in that place.

* Supplied with the tool

N.B.

ASSEMBLE THE LOWER HOUSING ON THE STEERING TUBE WITH A TUBE SECTION OF AN ADEQUATE DIAMETER.

Specific tooling

020021Y Front suspension service tool

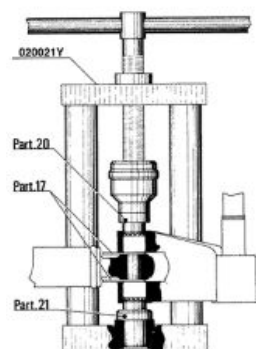

001330Y Tool for fitting steering seats**Recommended products****AGIP GREASE PV2 Grease for control levers on the engine**

White anhydrous-calcium based grease to protect roller bearings; temperature range between -20 °C and +120 °C; NLGI 2; ISO-L-XBCIB2

Refitting

When fitting the fork, lubricate with the steering bearing tracks with the recommended grease. Tighten the lower ring nut "A" and the upper ring nut "B" to the specified torque

Recommended products**AGIP GREASE PV2 Grease for the steering bearings, pin seats and swinging arm**

White anhydrous-calcium based protective grease for roller bearings; temperature range between -20 C and +120 C; NLGI 2; ISO-L-XBCIB2.

Locking torques (N*m)

Steering lower ring nut 8 ÷ 10 Steering upper ring nut 35 ÷ 40

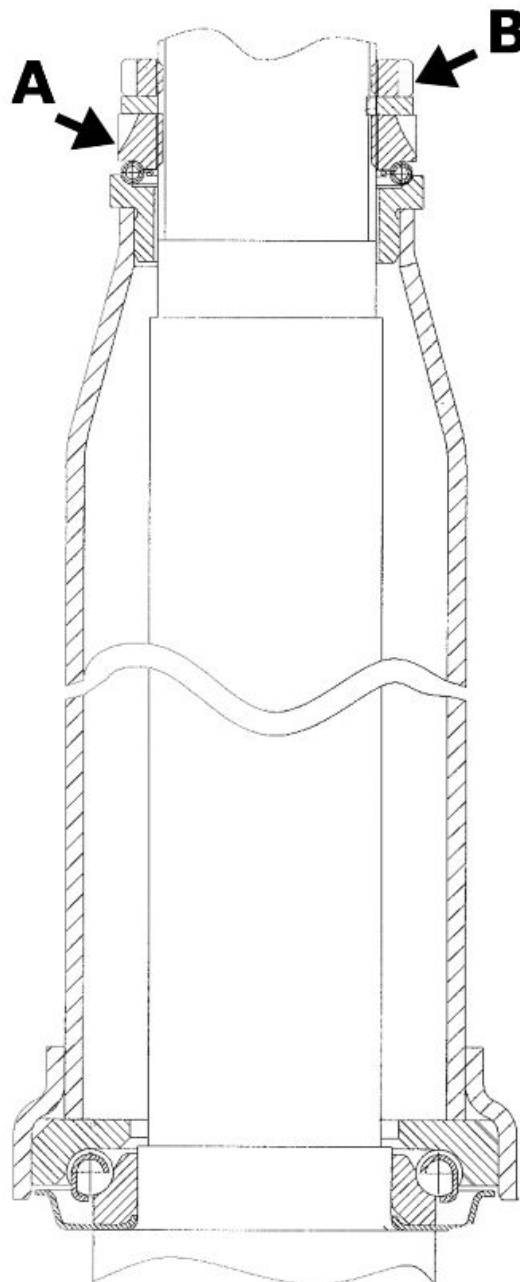
**CAUTION**

USE NEW ROLLER CASINGS, PIN, SEALING RINGS AND DUST GUARDS FOR REFITTING.

Front shock absorber

Removal

- Remove the steering tube
- Remove the shock absorber lower clamps
- Remove the shock absorber upper clamps



Refitting

To refit, carry out the removal operations in reverse order, observing the prescribed tightening torques.

Locking torques (N*m)

shock absorber lower clamp 20 - 27 Nm shock absorber upper clamp 20 ÷ 30

Shock-absorber - calliper bracket

Removal

- Remove the front wheel hub with the brake disc
- Remove the front shock absorber lower clamps



- Remove the bracket locking Seeger ring
- Unscrew the bracket



- Before refitting the bracket in the wheel axle, place the O-ring as shown in the photograph so that it is correctly placed after fitting the bracket.
- Refit the washer and the Seeger ring.
- Refit the lower screws fixing the shock absorber to the bracket and tighten at the prescribed torque



Locking torques (N*m)

Shock absorber lower clamp 20 ÷ 27

Overhaul

- The bracket for the shock absorber -calliper attachment has two roller bearings separated one from the other as shown in the photograph



- Remove the two roller bearings from the bracket with the specific tool operating on the shock absorber attachment side as shown in the photograph



Specific tooling

020376Y Adaptor handle

020441Y 26 x 28 mm adaptor

020365Y 22 mm guide

-
- Remove the oil seal on the wheel hub side with the screwdriver as shown in the photograph



-
- Suitably hold the brake calliper - shock absorber attachment bracket
 - Fit a new oil seal and move it until it stops using the specific tool

Specific tooling**020376Y Adaptor handle****020360Y Adaptor 52 x 55 mm**

-
- Assemble a new roller bearing on the shock absorber side and move it until it stops using the specific tool

Specific tooling**020036Y Punch**

-
- Suitably hold the brake calliper - shock absorber attachment bracket
 - Assemble a new roller bearing on the wheel hub side and move it until it stops using the specific tool

Specific tooling**020037Y Punch**

Refitting

- Refit the parts in reverse order of the removal operation.

CAUTION

BEFORE CARRYING OUT REFITTING OPERATIONS IN THE AREAS MARKED WITH AN ASTERISK, LUBRICATE THEM WITH THE RECOMMENDED PRODUCT

Specific tooling

020036Y Punch

020037Y Punch

Recommended products

AGIP GREASE PV2 Grease for control levers on the engine

White anhydrous-calcium based grease to protect roller bearings; temperature range between -20 °C and +120 °C; NLGI 2; ISO-L-XBCIB2

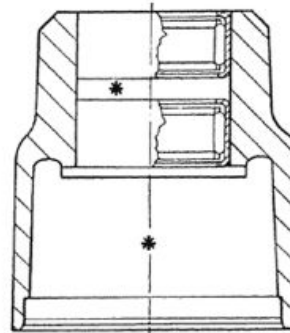

Steering bearing

Removal

- Use the specific tool both to remove the lower seat of the upper bearing and to remove the upper seat of the lower bearing fitted on the chassis.

N.B.

TO REMOVE THE LOWER SEAT OF THE LOWER STEERING BEARING JUST USE A SCREWDRIVER AS A LEVER BETWEEN THE SEATING AND THE SLEEVE.

Specific tooling

020004Y Punch for removing fifth wheels from headstock

- Remove the fifth wheel fitting and the dust guard on the steering tube as shown in figure, using the specific tool. Proceed giving a few taps with the mallet.

Specific tooling

020004Y Punch for removing fifth wheels from headstock



-
- Refit the fifth wheel fitting and the dust guard on the steering tube until they stop, using the specific tool.

Specific tooling

006029Y Punch for fitting fifth wheel seat on steering tube



Rear

Removing the rear wheel

- Straighten the split pin and remove the cap.
- Remove the wheel acting on the central fixing point.

Refitting the rear wheel

- Fit the wheel, tighten the nut to the prescribed torque.
- Refit the cap and the split pin folding it correctly as shown in the figure.

Locking torques (N*m)

Locking torque 137 ÷ 152 Nm

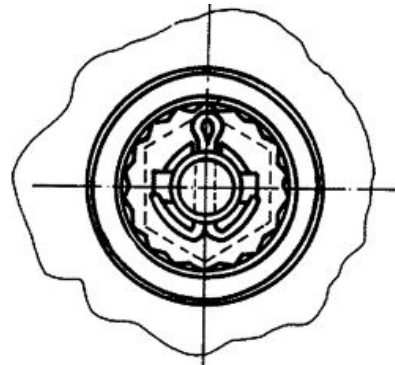

Swing-arm

Removal

Remove the swinging arm acting on the three clamps shown in the figure.

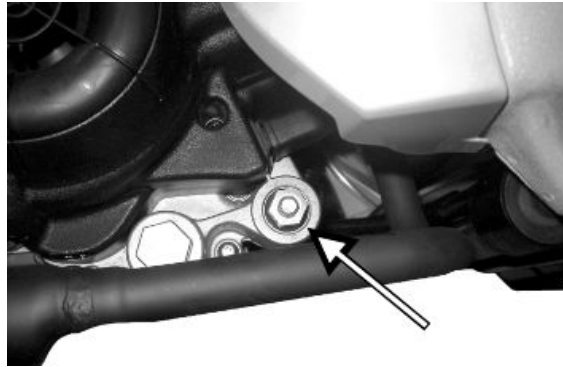

Refitting

For refitting, respect the locking torques

Locking torques (N*m)

Part C 33 ÷ 41 Part B 44 ÷ 52 Part A 33 ÷ 41

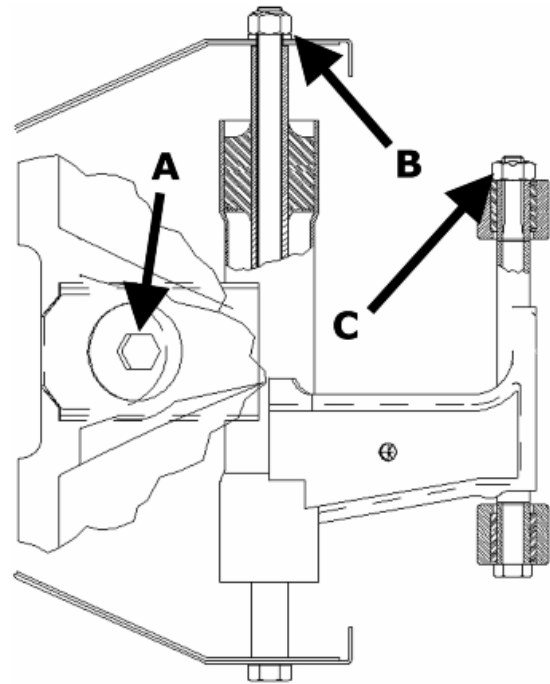

Shock absorbers

Removal

- To replace the shock absorber remove the battery access flap to reach and remove the shock absorber/ frame anchoring nut. Then remove the shock absorber/engine anchorage nut.

- When refitting, tighten the shock absorber/chassis anchoring nut and the shock absorber/engine pin to the prescribed torque.



Locking torques (N*m)

Shock absorber/engine pin torque 33 to 41 N·m Shock absorber/frame nut torque 20 to 25 Nm

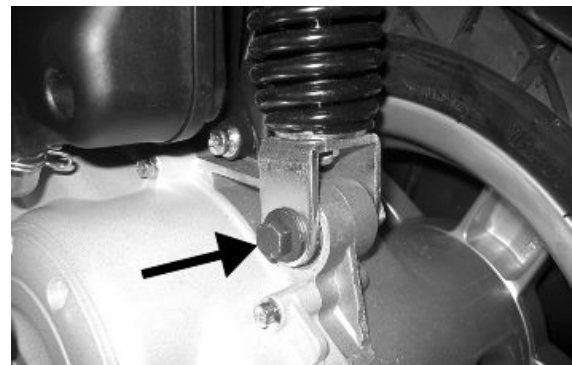

INDEX OF TOPICS

BRAKING SYSTEM

BRAK SYS

1. Tank cover.
- 2 - Pump body.
- 3 - Brake lever.
- 4 - Pump plunger.
- 5- Oil delivery hose.
- 6 - Protection cap for air bleed screw.
- 7- Calliper.
- 8- Dust guard
- 9- Piston sealing ring.
- 10- Piston.
- 11 - Brake pad.
- 12 - Brake disc.

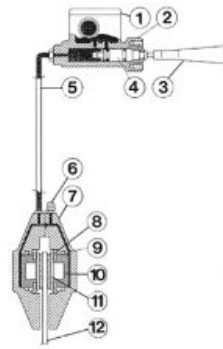

Front brake calliper

Removal

- Detach the oil brake hose from calliper, pouring the fluid inside a container.
- Remove the mountings indicated in the figure.
- When refitting, tighten the nuts to the prescribed torque.
- Bleed the system.

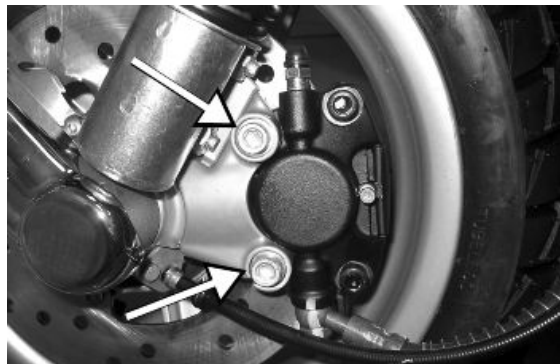

Locking torques (N*m)

Calliper tightening screw 20 ÷ 25 Nm
Brake fluid tube calliper 20 ÷ 25 Nm

Overhaul

- Remove the calliper assembling bolts and take out the internal bodies and components. If necessary, in order to make it easier to take out the plungers, inject (shorts blasts of) compressed air through the brake fluid pipe.
- Check that the cylinders of the internal and external body of the calliper do not show scratches or signs of erosion; otherwise, replace the entire calliper.

CAUTION

ALL THE INTERNAL COMPONENTS MUST BE REPLACED EVERY TIME THE CALLIPER IS SERVICED.

Fit to the calliper body:

- the sealing rings (1-2);
- the plungers (3);
- bed the O-Ring gasket (4) on a calliper body.

- Couple the internal body with the external one with assembling bolts. Refitting the pads and purging air (see previous sections).
- Place the calliper on the disc and lock it to the support by tightening the bolts.
- Lock the pipe joint to the calliper at the prescribed torque.

Upon fitting, the parts must be perfectly clean and **free of traces of oil, diesel fuel, grease, etc..** They should be washed thoroughly in denatured alcohol before proceeding.

The sealing rings must be immersed in the operating liquid; the use of the **PRF1** protection is tolerated.

CAUTION

RUBBER PARTS SHOULD NEVER BE LEFT IN ALCOHOL FOR LONGER THAN 20 SECONDS. AFTER WASHING, THE PIECES MUST BE DRIED WITH A BLAST OF COMPRESSED AIR AND A CLEAN CLOTH.

Locking torques (N*m)

Screw tightening calliper to the support 20 ÷ 25 Attachment to the calliper 25 ÷ 30 Nm

- 1 DUST GUARDS
- 2 SEALING RINGS
- 3 PLUNGERS
- 4 O-RING GASKET

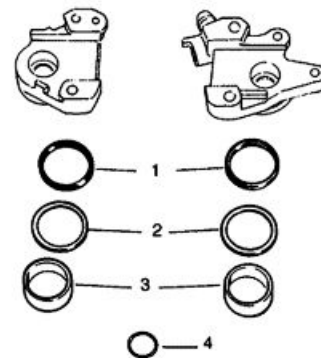

Front brake disc

Removal

- Should the brake disc be replaced, when refitting the hub, apply recommended product on the fixing bolts.

Tighten to the specified torque.

N.B.

THE SURFACE OF THE DISC WITH THE STAMPED ARROW INDICATING THE DIRECTION OF ROTATION MUST FACE THE SHOCK ABSORBER.

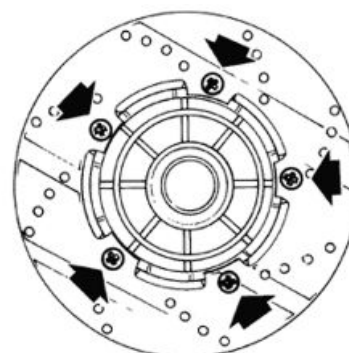

Recommended products

Loctite 242 product description

Apply LOCTITE medium type 242 threadlock

Locking torques (N*m)

tightening torque $5 \div 6.5$ Nm

Disc Inspection

Specific tooling

020335Y Magnetic support for dial gauge

Characteristic

Max oscillation allowed

0.1 mm.

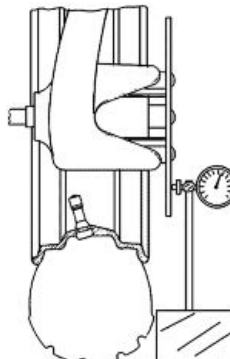

Front brake pads

Removal

- Pads must be replaced when the friction material thickness reaches the wear limit.

- To replace:

remove the protection cover, the bolt and the leaf spring. Slide off the pads and replace them once the plungers are down. Carry out these operations in reverse order to fit.

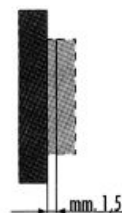

CAUTION

BEFORE USING THE BRAKE, OPERATE THE LEVER A FEW TIMES.

Front

-Once the bleed valve is closed, fill the system with brake liquid to the maximum level.

-Undo the bleed screw.

-Apply the tube of the special tool to the bleed screws.

When bleeding it is necessary to fill the oil tank in continuation while working with a MITYVAC pump on the bleed screws until no more air comes out of the system.

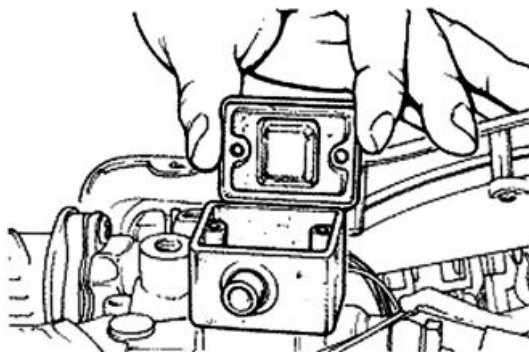

The operation is finished when just oil comes out of the bleed screws.

-Do up the bleed screw.

-When the operation is over, tighten up the oil bleed screw to the prescribed torque.

N.B.

IF AIR CONTINUES TO COME OUT DURING PURGING, EXAMINE ALL THE FITTINGS: IF SAID FITTINGS DO NOT SHOW SIGNS OF BEING FAULTY, LOOK FOR THE AIR INPUT AMONG THE VARIOUS SEALS ON THE PUMP AND CALLIPER PISTONS.

CAUTION

- DURING THE OPERATIONS, THE VEHICLE MUST BE ON THE STAND AND LEVEL.

N.B.

DURING PURGING FREQUENTLY CHECK THE LEVEL TO PREVENT AIR GETTING INTO THE SYSTEM THROUGH THE PUMP.

WARNING

- BRAKING CIRCUIT FLUID IS HYGROSCOPIC. IT ABSORBS HUMIDITY FROM THE SURROUNDING AIR.

IF THE LEVEL OF HUMIDITY IN THE BRAKING FLUID EXCEEDS A GIVEN VALUE, BRAKING EFFICIENCY WILL BE REDUCED.

THEREFORE, ALWAYS USE FLUID FROM SEALED CONTAINERS.

UNDER NORMAL DRIVING AND CLIMATIC CONDITIONS YOU SHOULD CHANGE THIS LIQUID EVERY TWO YEARS.

IF THE BRAKES ARE USED INTENSELY AND/OR IN HARSH CONDITIONS, CHANGE THE FLUID MORE FREQUENTLY.

CAUTION

WHEN CARRYING OUT THE OPERATION, BRAKE FLUID MAY LEAK FROM BETWEEN THE BLEED SCREW AND ITS SEAT ON THE CALLIPER.

CAREFULLY DRY THE CALLIPER AND DEGREASE THE DISC SHOULD THERE BE OIL ON IT.

Specific tooling

020329Y MityVac vacuum-operated pump

Recommended products

AGIP BRAKE 4 Brake fluid

FMVSS DOT4 Synthetic fluid

Locking torques (N*m)

Oil bleed screw 7 ÷ 10

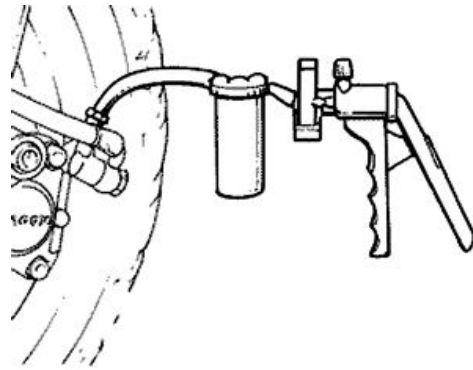

Front brake pump

Removal

- Bleed the circuit and drain the brake fluid through the bleeding screw located on the calliper and actuate the brake lever until no more fluid flows out.
- Remove the oil pump from the handlebar; remove the brake lever and then remove the wheel cylinder.

- 1 - Tank cap screw.
2. Tank cover.
3. Diaphragm.
4. Bellows.
5. Sealing ring.
6. Piston.
7. Gasket.
- 8 - Spring

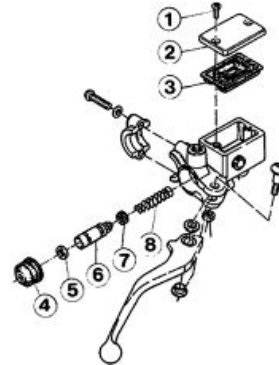

CAUTION

- THE PRESENCE OF BRAKE FLUID ON THE DISC OR BRAKE PADS REDUCES THE BRAKING EFFICIENCY. IN THIS CASE, REPLACE THE PADS AND CLEAN THE DISC WITH A HIGH-QUALITY SOLVENT.

CONTACT WITH BRAKE FLUID WILL DAMAGE PAINTED SURFACES.

RUBBER PARTS SHOULD NEVER BE LEFT IN ALCOHOL FOR LONGER THAN 20 SECONDS. AFTER WASHING, THE PIECES MUST BE DRIED WITH A BLAST OF COMPRESSED AIR AND A CLEAN CLOTH.

THE SEALING RINGS MUST BE IMMERSSED IN THE OPERATING LIQUID.

Refitting

Before fitting, the parts must be perfectly clean and free of traces of oil, diesel fuel, grease, etc.. They should be washed thoroughly in denatured alcohol before proceeding.

- Reinstall the individual parts in the reverse order to the removal, paying attention to the correct positioning of the rubber parts in order to ensure leak tightness.

- 1 - Tank cap screw.
- 2. Tank cover.
- 3. Diaphragm.
- 4. Bellows.
- 5. Sealing ring.
- 6. Piston.
- 7. Gasket.
- 8. Spring.

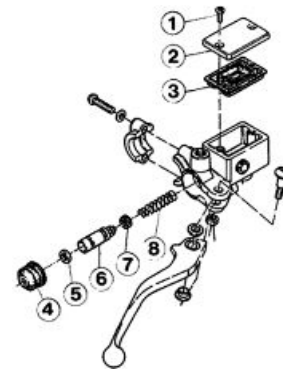

Rear drum brake

Once the muffler and the wheel have been removed, follow these steps:

1. Remove the shoe spring using the specific spanner.
2. Remove the shoe with the aid of a lever.
3. Refit the new shoes giving a few taps with the mallet.
4. Attach the spring using the specific pliers.

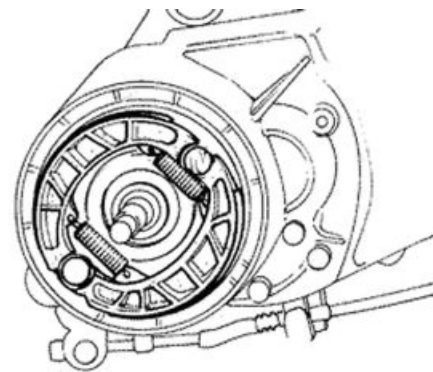

Specific tooling

020325Y Brake-shoe spring calliper

INDEX OF TOPICS

CHASSIS

CHAS

Rear handlebar cover

Undo the screws as shown in the figure and remove the handlebar rear section.

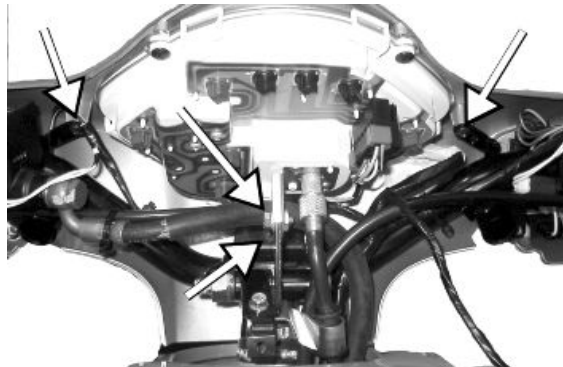

Instrument panel

Operate the 4 screws shown in the figure to replace the instrument panel.

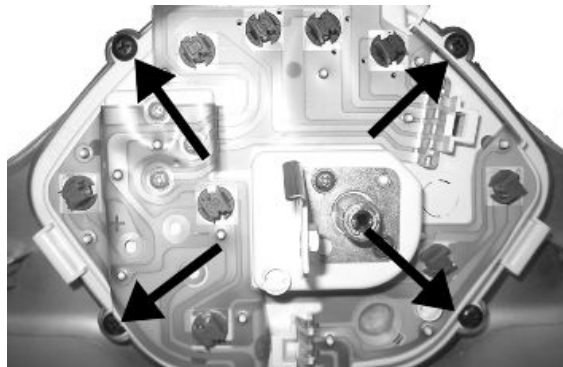

Front handlebar cover

- Remove the 2 screws in the rear handlebar cover and the screw under the headlamp.
- Pull up and detach the front handlebar cover, disconnect the headlight assembly connections.





Headlight assy.

After removing the front handlebar cover, operate the 4 screws shown in the figure and remove the headlight.



Knee-guard

- Unscrew the 2 screws shown in the figure placed under the front grille.
- Remove the 3 screws shown in the figure, placed inside the glove-box; they can be reached after opening the glove-box door.

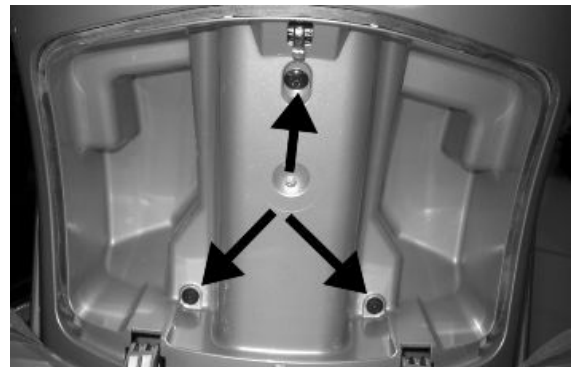
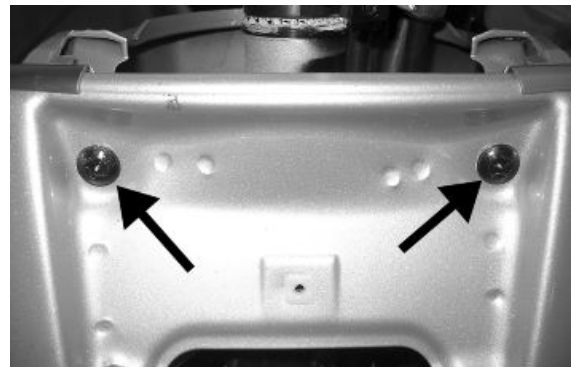

Footrest

- Operate on the 3 screws shown in the figure once the glove-box and fairing have been removed.

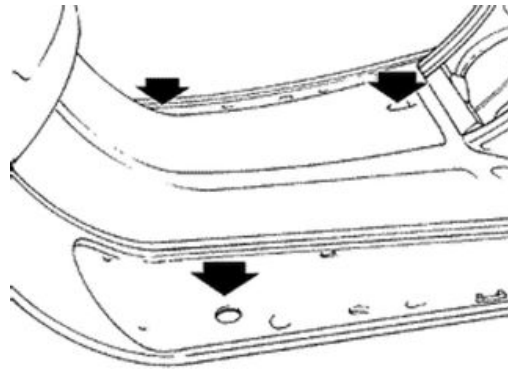

Air filter

- Remove the helmet compartment.
- after removing the side fairing, remove the 2 screws fixing the filter box to the engine, indicated in the figure.
- Remove the two clamps indicated in the figure

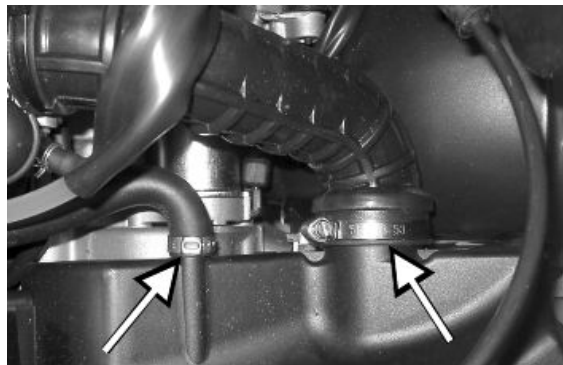
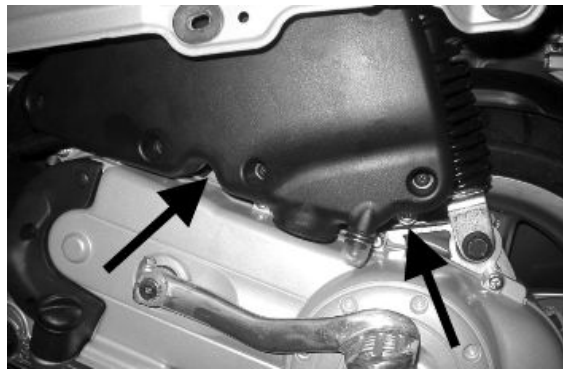

Front mudguard

- First remove the steering tube and uncouple the front brake pipes from the calliper in order to remove the front mudguard
- Remove the three mudguard-steering tube clamps indicated in the figure

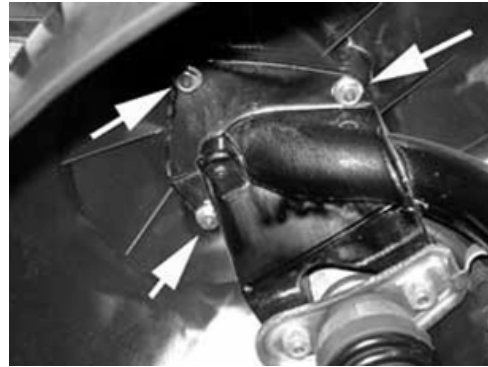

Front central cover

- Remove the "PIAGGIO" clip-on badge
- Unscrew the screw indicated in the figure
- Remove the grille



INDEX OF TOPICS

PRE-DELIVERY

PRE DE

Aesthetic inspection

- Paintwork
- Joins between plastic fairings
- Damage
- Cleanness

Tightening torques inspection

Fastenings check

- All tightening torques
- External fairing screws

SAFETY LOCKS

Name	Torque in Nm
Handlebar tightening	40 ÷ 50
Lower steering ring nut	8 ÷ 10
Upper steering ring nut	30 ÷ 40
Front wheel axle nut	75 ÷ 90
Rear wheel nut	137 ÷ 152
Rear shock absorber-engine nut	33 ÷ 41
Frame-rear shock absorber nut	20 ÷ 25
Engine-swinging arm bolt	33 ÷ 41
Floating arm-frame pin	44 ÷ 52

Electrical system

- Check that voltage is at least 12.6V; if not, recharge the battery according to directions.

Check the following devices:

- Keyswitch
- Headlight full/dipped beam, panel indicator lights, side lights
- Headlight adjustment
- Taillight
- Brake light (front and rear brake)
- Turn signals and relative indicators
- Speedometer and instrument panel lighting
- Horn
- Start button

CAUTION

**TO ENSURE BEST PERFORMANCE, BATTERY MUST BE CHARGED BEFORE USE ONLY IF VOLTAGE IS BELOW 12,7V. FAILURE TO RECHARGE THE BATTERY BEFORE ITS FIRST USE MAY SHORTEN THE BATTERY'S LIFE.
WHEN INSTALLING THE BATTERY ON THE VEHICLE CONNECT THE POSITIVE LEAD BEFORE THE NEGATIVE LEAD.**

NEVER USE A FUSE WITH A HIGHER RATING THAN THE PRESCRIBED VALUE. THE USE OF UNSUITABLY RATED FUSES CAN RESULT IN WIDESPREAD DAMAGE TO THE VEHICLE, INCLUDING FIRE.

WARNING

KEEP THE BATTERY WELL CLEAR OF NAKED FLAMES AND SPARKS DURING CHARGING. REMOVE THE BATTERY FROM THE VEHICLE BY DISCONNECTING THE NEGATIVE LEAD FIRST.

PROTECT THE EYES WHEN WORKING WITH BATTERIES OR IN THEIR IMMEDIATE VICINITY. KEEP BATTERIES AWAY FROM CHILDREN. BATTERY ELECTROLYTE CONTAINS SULPHURIC ACID. BATTERY ELECTROLYTE IS POISONOUS AND CAUSES SEVERE BURNS. AVOID CONTACT WITH THE EYES, SKIN AND CLOTHES. DO NOT FORCE OR DAMAGE THE EXTERNAL CASE.

IN CASE OF CONTACT WITH THE EYES AND/OR SKIN, WASH THE AFFECTED AREA WITH PLENTY OF CLEAN WATER FOR ABOUT 15 MINUTES AND SEEK MEDICAL ASSISTANCE IMMEDIATELY.

IN THE CASE OF INGESTION OF ELECTROLYTE DRINK PLENTY OF WATER OR VEGETABLE OIL AND CALL A DOCTOR IMMEDIATELY.

Levels check

- Brake fluid
 - Hub oil
 - Engine oil level
-

Road test

- Cold start.
 - Speedometer check.
 - Throttle check.
 - Riding stability.
 - Front and rear brake efficiency.
 - Front and rear shock-absorbers.
 - Unusual noises.
 - Hot engine restart.
 - Leakages (after trial run).
-

Functional inspection

- Brake lever excursion.
- Throttle excursion and adjustment.
- Homogeneous steering turning.

Other

- Tyre inflation pressure
 - Locks
 - Mirrors and accessories
 - Toolkit, user handbook, guarantee certificate and customer service card
-

CAUTION

CHECK AND ADJUST TYRE PRESSURE WITH TYRES AT AMBIENT TEMPERATURE.

CAUTION

NEVER EXCEED THE RECOMMENDED INFLATION PRESSURES OR TYRES MAY BURST.

WARNING

BE VERY CAREFUL WHEN HANDLING FUEL.

INDEX OF TOPICS

TIME

TIME

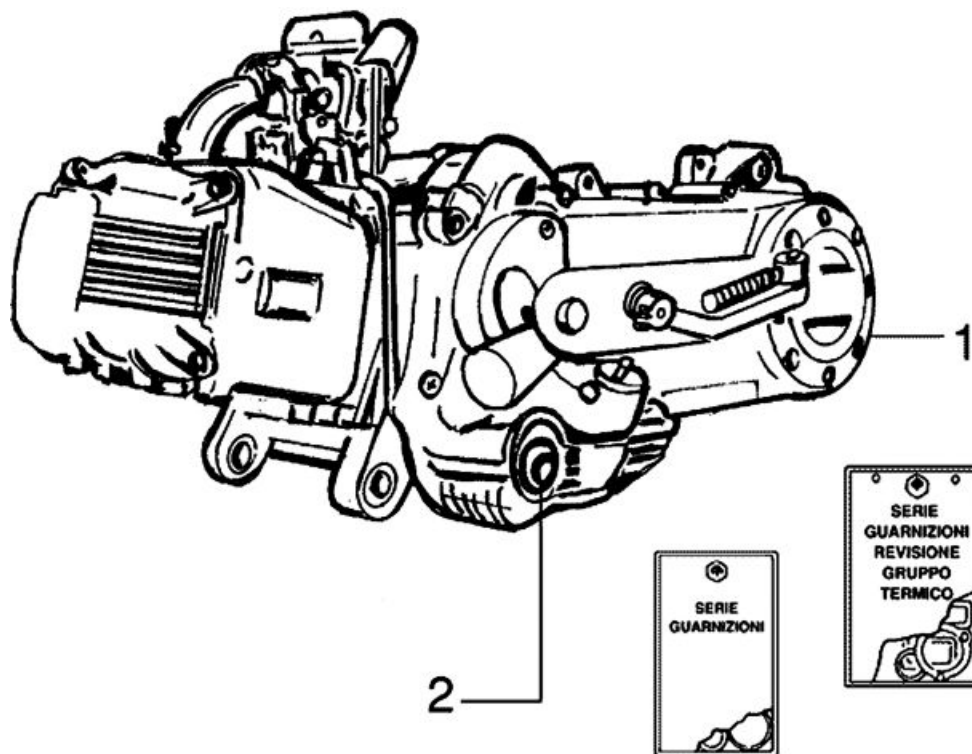
Engine
**ENGINE**

	Code	Action	Duration
1	001001	Engine from frame - Removal and refit.	
2	003064	Engine oil - change	

Crankcase

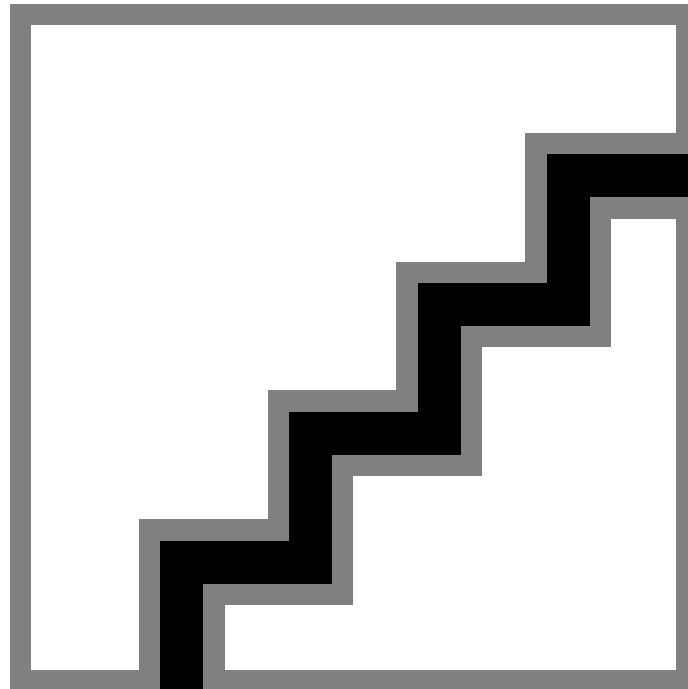

CRANKCASE

	Code	Action	Duration
1	001133	Engine crankcase - replace	

Crankshaft

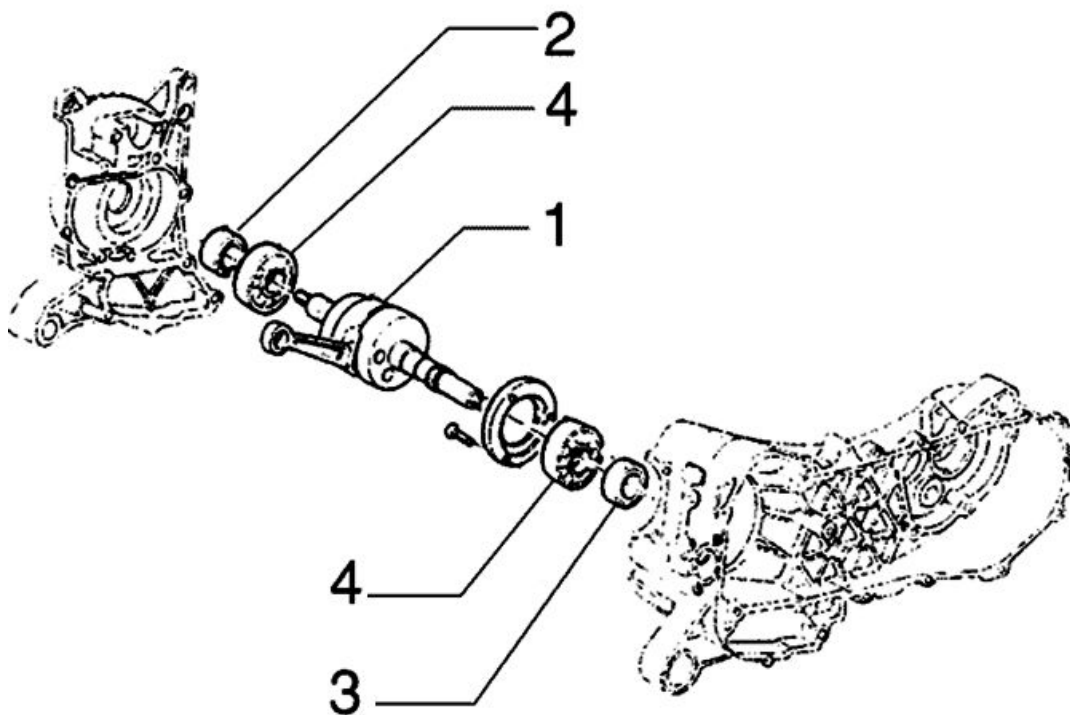

CRANKSHAFT

	Code	Action	Duration
1	001117	Crankshaft - Replacement	
2	001099	Oil seal, flywheel side - Replacement	
3	001100	Oil seal, clutch side - Replacement	
4	001118	Main bearings - Replacement	

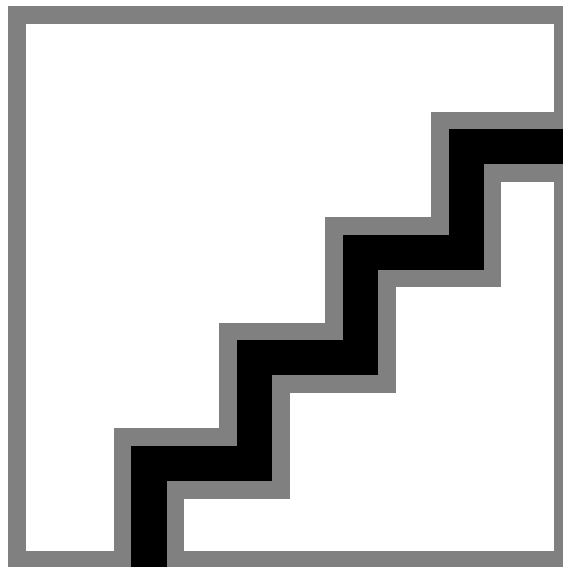
Cylinder assy.**CYLINDER- PISTON**

	Code	Action	Duration
1	001002	Cylinder Piston - Replacement	
2	001107	Cylinder Piston - Inspection / Cleaning	

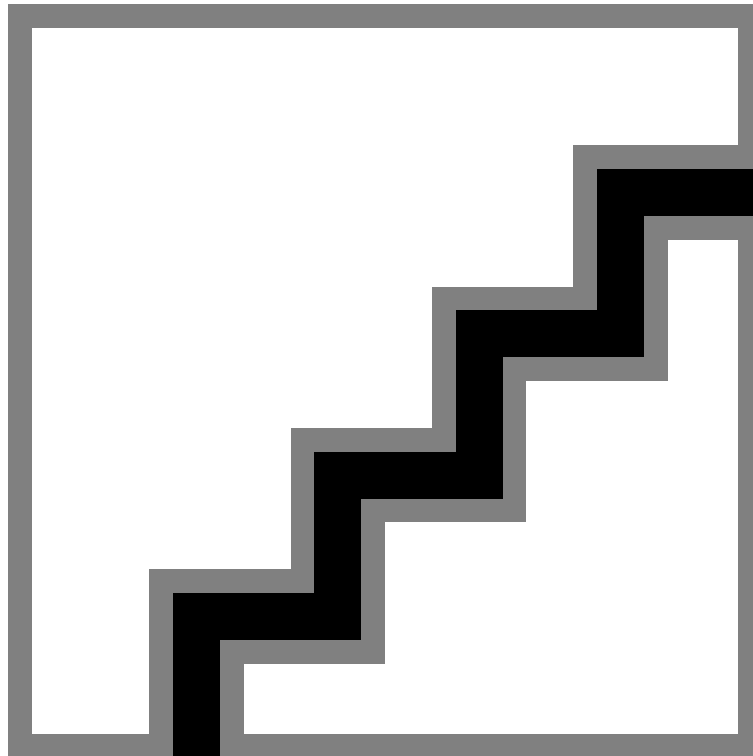
Cylinder head assy.**HEAD**

	Code	Action	Duration
1	001056	Head gasket - change	
2	001045	Valves - Replacement	
3	001126	Head - Replacement	

Rocker arms support assy.

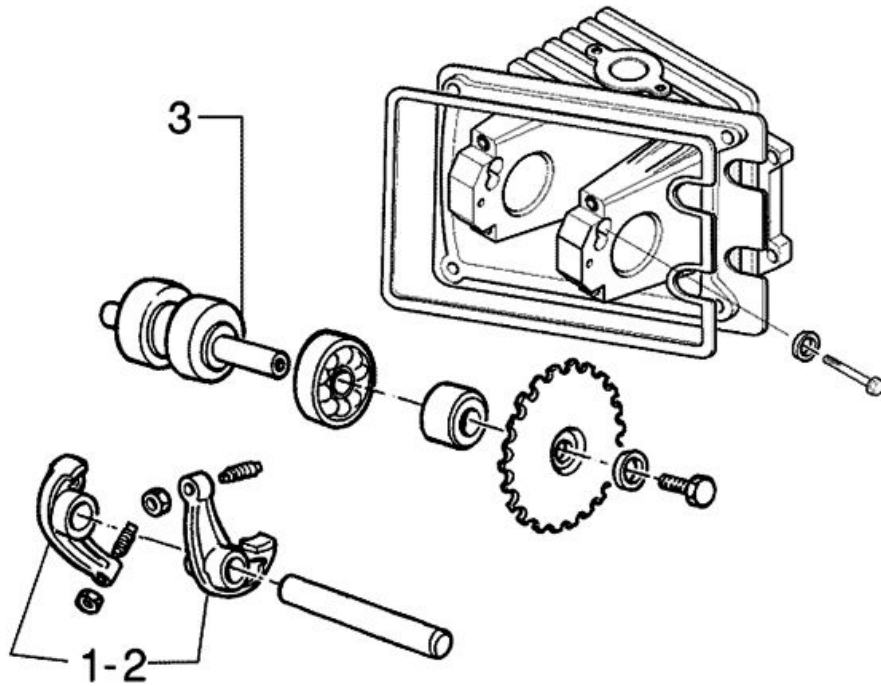

CAMSHAFT SUPPORT

	Code	Action	Duration
1	001049	Valve clearance - Adjustment	
2	001148	Valve rocking levers - Replacement	
3	001044	Camshaft - Replacement	

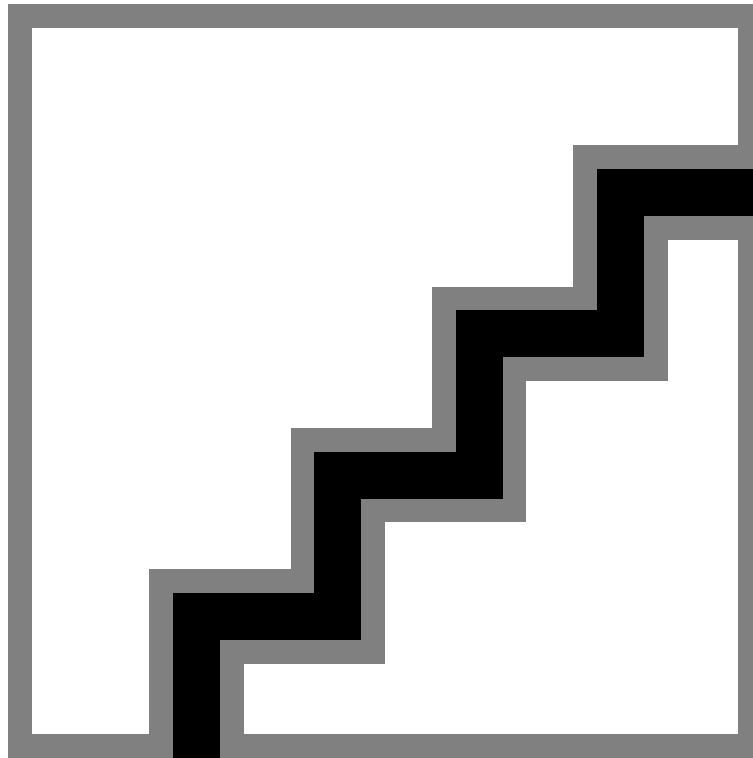
Cylinder head cover**HEAD COVER**

	Code	Action	Duration
1	001093	Spark plug - Replacement	
2	001088	Head cover gasket - change	
3	001097	Cooling hood - Replacement	
4	001089	Head cover - change	

Driven pulley

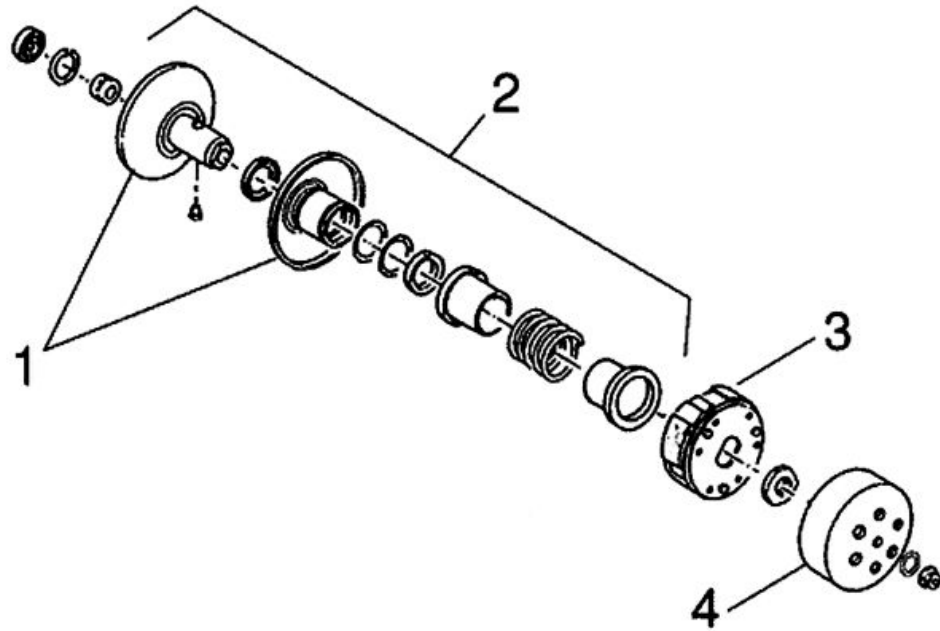

DRIVEN PULLEY - CLUTCH

	Code	Action	Duration
1	001110	Driven pulley- Replacement	
2	001012	Driven pulley - Overhaul	
3	001022	Clutch - Replacement	
4	001155	Clutch bell housing - Replacement	

Oil pump

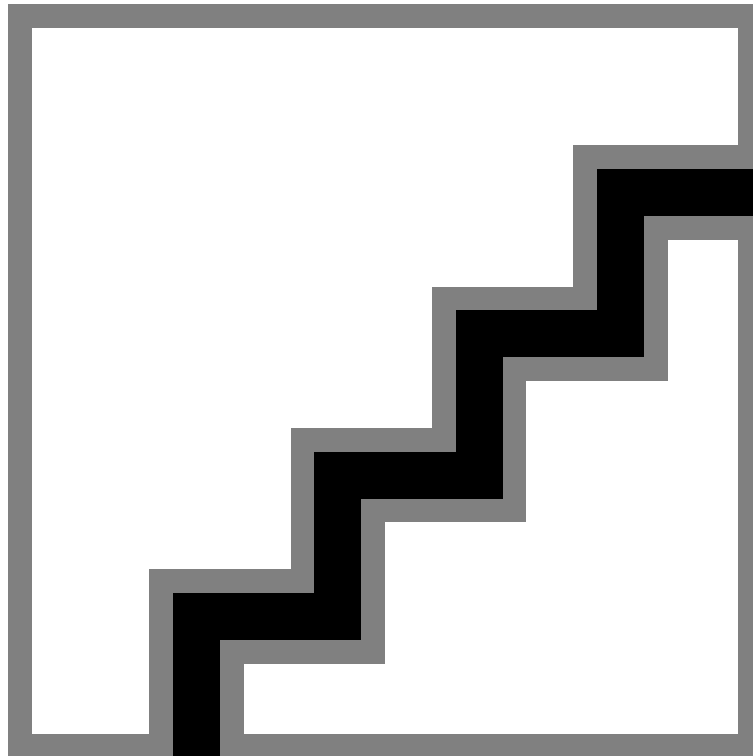
**OIL PUMP**

	Code	Action	Duration
1	001051	Belt/Timing chain - change	
2	001112	Oil pump - change	
3	001042	Oil pump - overhaul	
4	001121	Chain cover oil seal - Re- placement	
5	001122	Oil pump chain - change	
6	001125	Chain guide pads - change	
7	001130	Oil sump - change	
8	001129	Chain tightener - overhaul and replace	

Final gear assy.

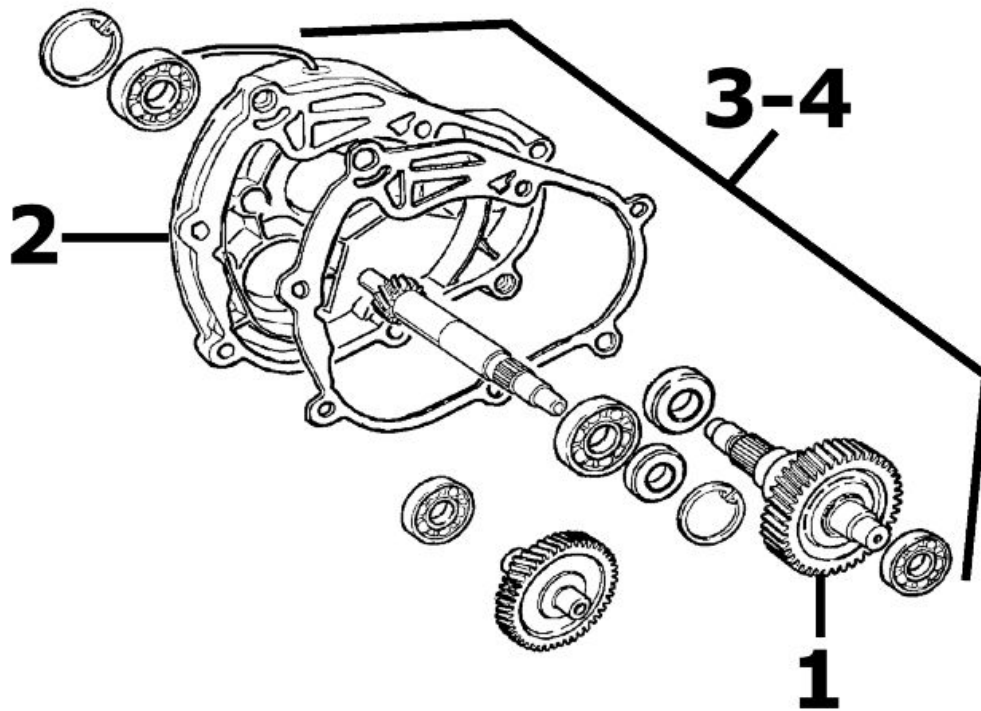
**FINAL REDUCTION GEAR ASSEMBLY**

	Code	Action	Duration
1	004125	Rear wheel axle - Replacement	
2	001156	Gear reduction unit cover - Replacement	
3	003065	Gear box oil - Replacement	
4	001010	Gear reduction unit - Inspection	

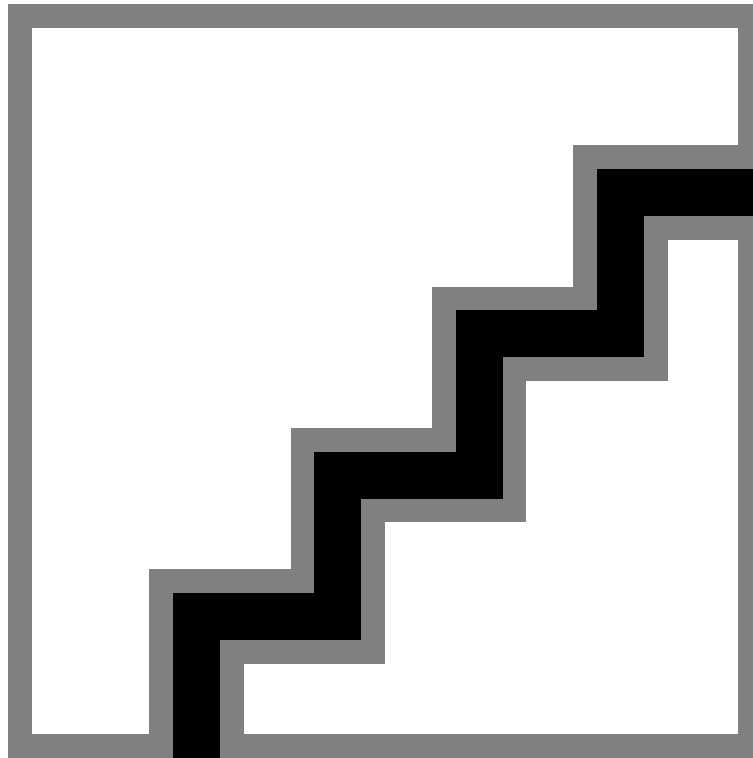
Driving pulley**DRIVING PULLEY**

	Code	Action	Duration
1	001177	Variator rollers / shoes - Replacement	
2	001086	Driving half-pulley - replace	
3	001066	Driving pulley - Removal and Refitting	
4	001011	Driving belt - Replacement	

Starter motor

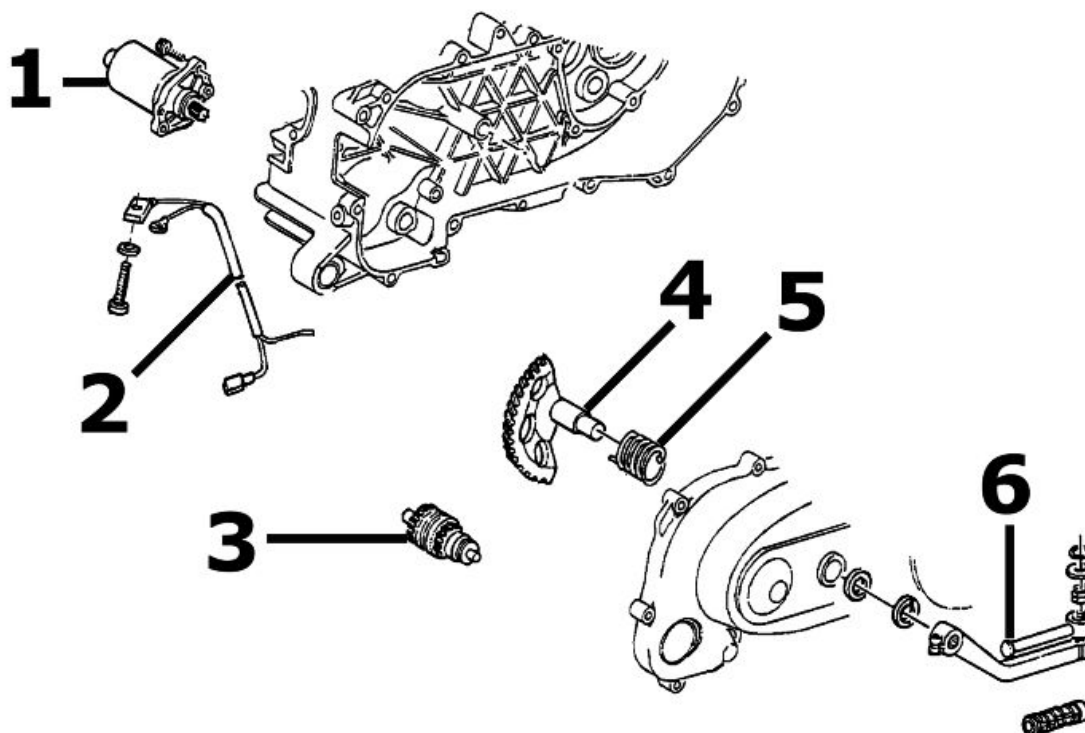

ELECTRICAL START-UP

	Code	Action	Duration
1	001020	Starter motor - Replacement	
2	005045	Starter motor cable harness - Replacement	
3	001017	Starter sprocket wheel - Replacement	
4	001021	Kick starter - Inspection	
5	008008	Starter spring pack - Replacement	
6	001084	Starter lever - Replacement	

Flywheel magneto

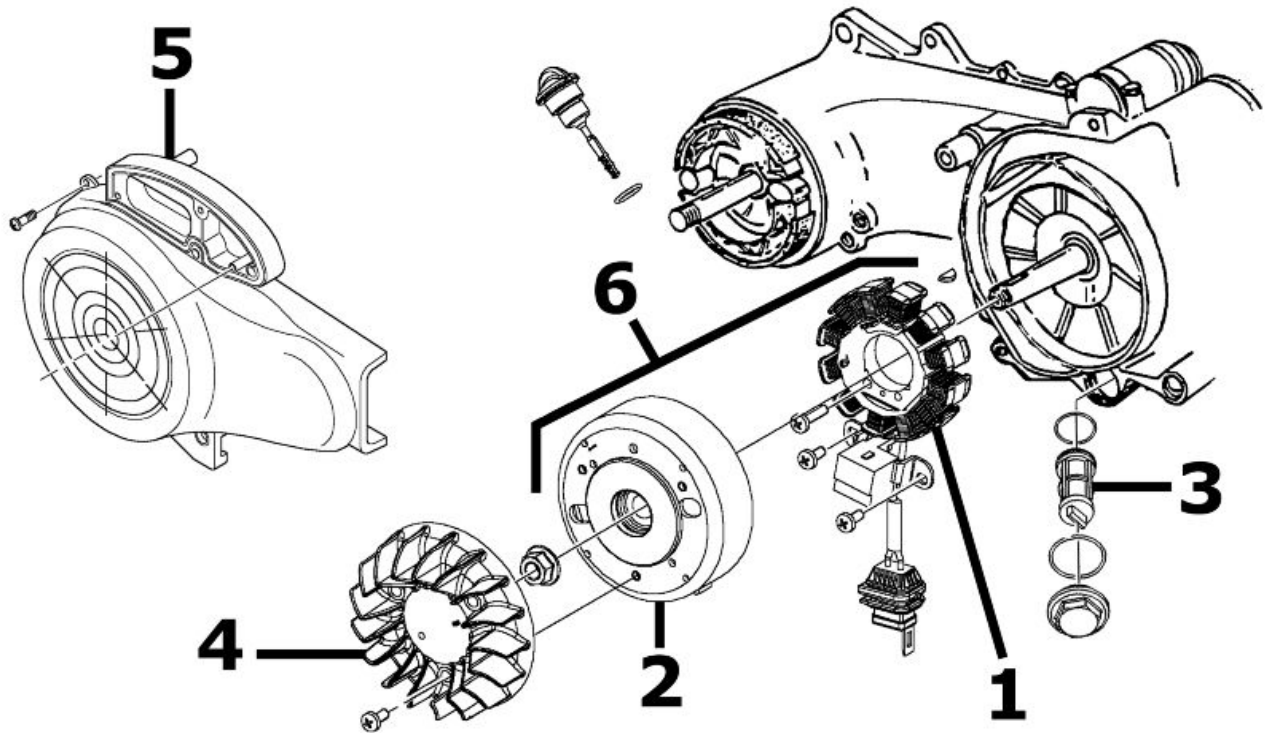
**FLYWHEEL MAGNETO**

	Code	Action	Duration
1	001067	Stator - Fitting and Refitting	
2	001173	Rotor - Replacement	
3	001102	Net oil filter - change / Cleaning	
4	001109	Cooling fan - Replacement	
5	001087	Flywheel cover - Replacement	
6	001058	Flywheel - Replacement	

Carburettor

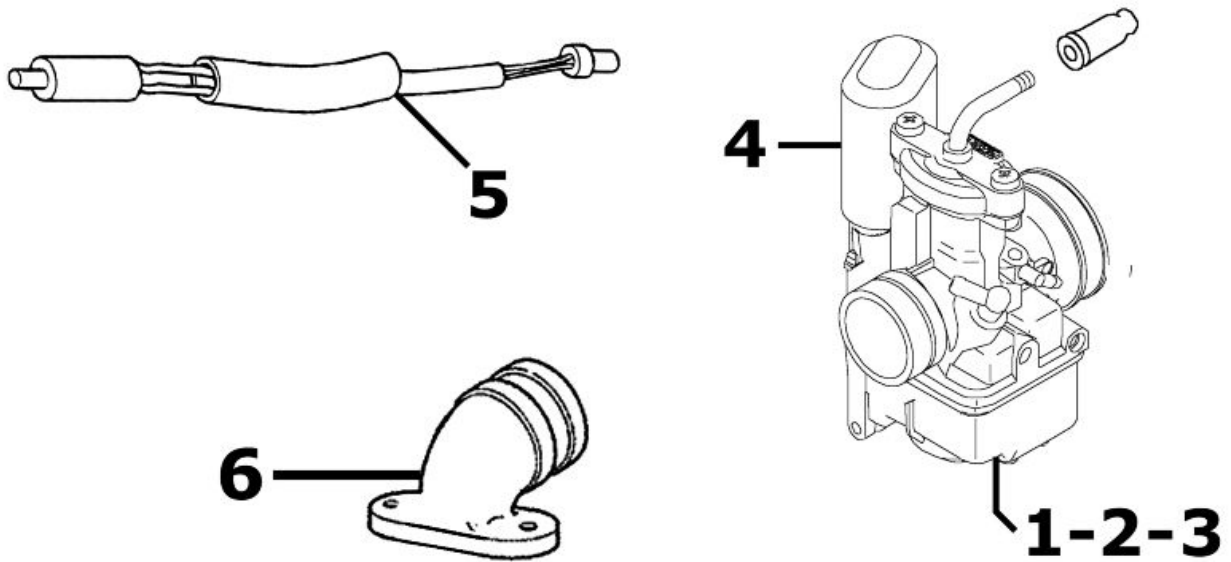

CARBURETTOR

	Code	Action	Duration
1	001063	Carburettor - Replacement	
2	001008	Carburettor - Inspection	
3	003058	Carburettor - Adjustment	
4	001081	Automatic choke - Replacement	
5	001082	Carburettor heating resistor - Replacement	
6	001013	Intake manifold - change	

Exhaust pipe

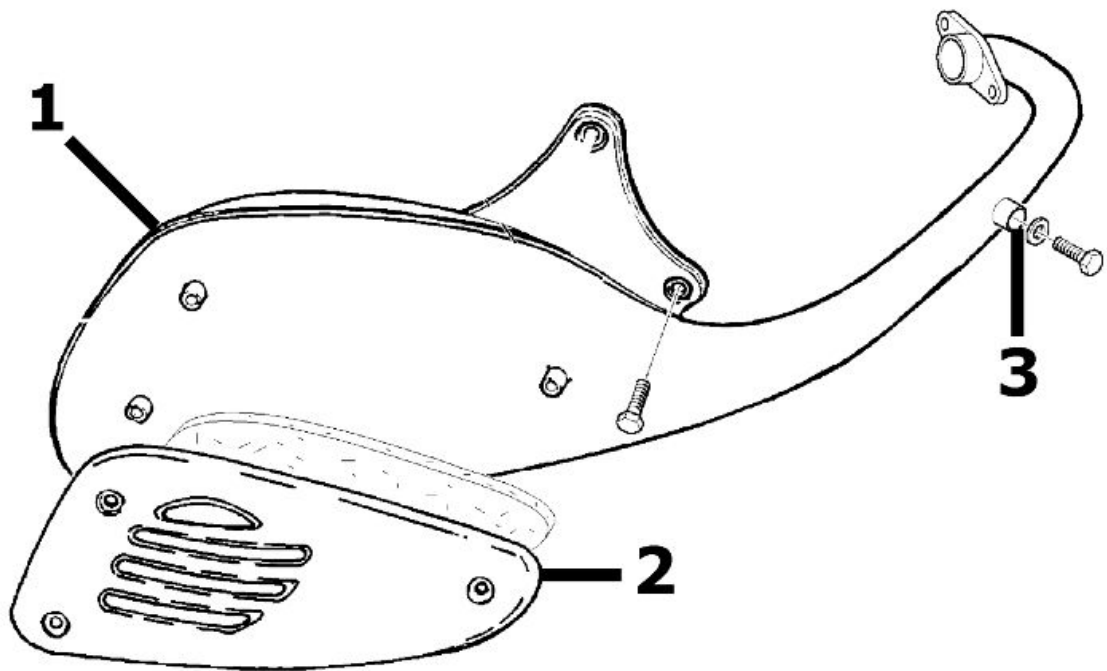
**MUFFLER**

	Code	Action	Duration
1	001009	Muffler - Replacement	
2	001095	Muffler guard - Replacement	
3	001136	Exhaust emissions - Adjustment	

Air cleaner

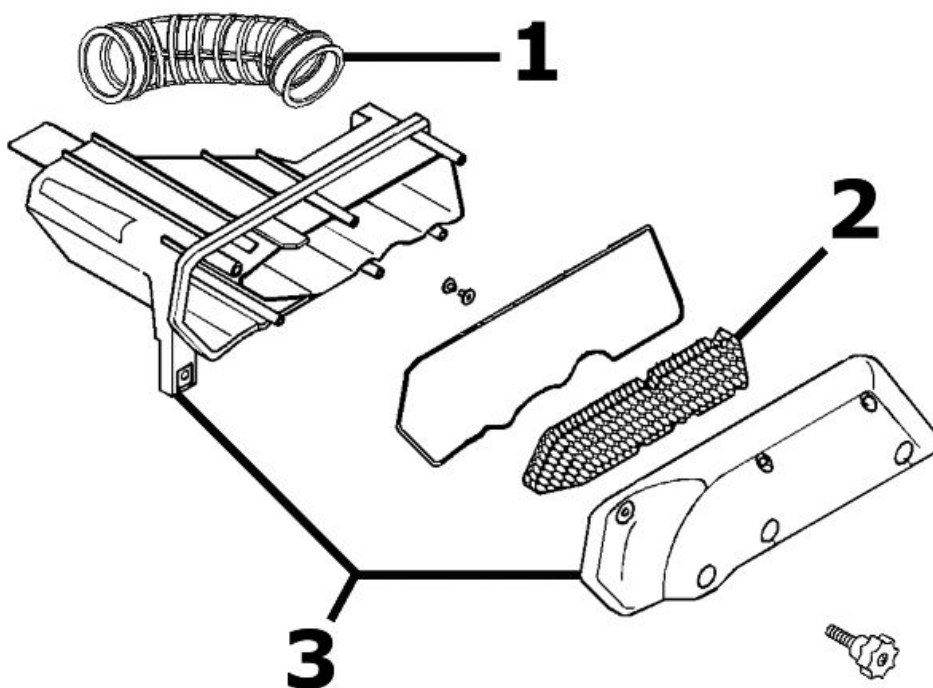

AIR CLEANER

	Code	Action	Duration
1	004122	Air cleaner carburettor fitting - Replacement	
2	001014	Air filter - Replacement / cleaning	
3	001015	Air filter box - Replacement	

Frame

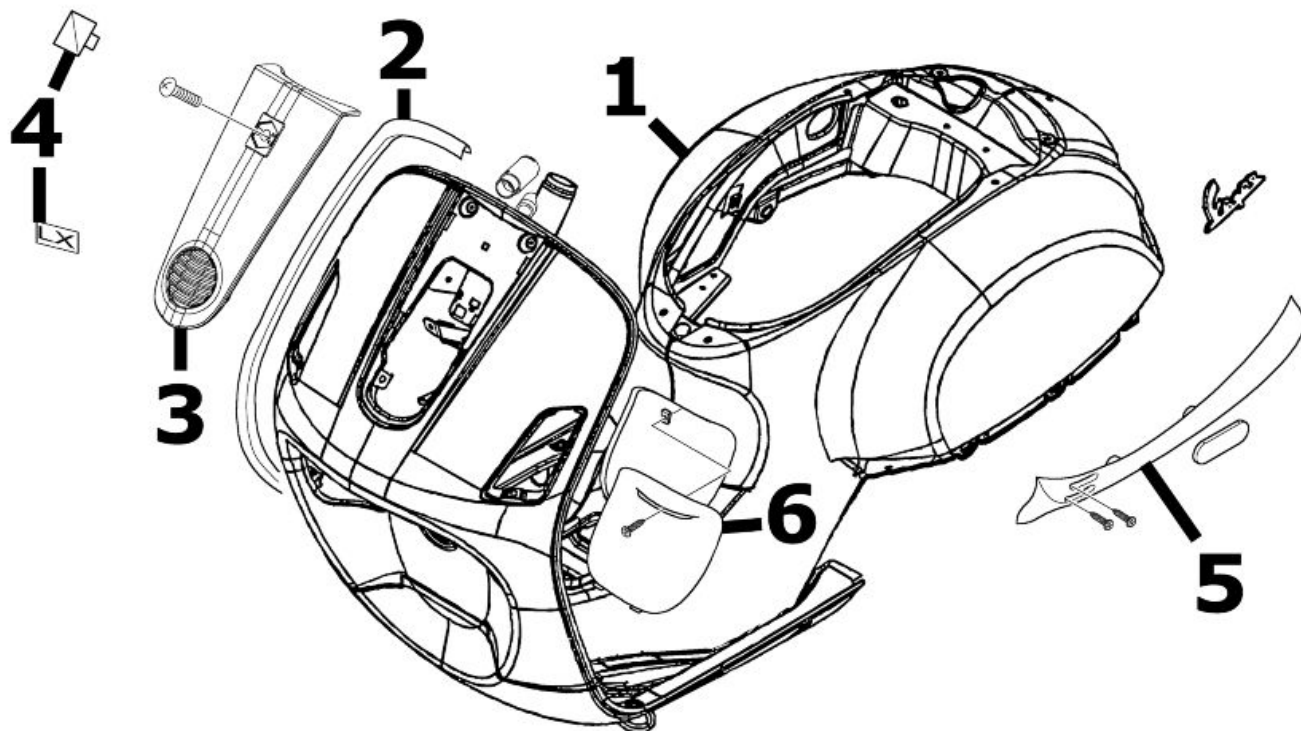
FRAME

	Code	Action	Duration
1	004001	Chassis - Replacement	
2	004023	Shield rim - Replacement	
3	004149	Shield central cover - Replacement	
4	004159	Plates / Stickers - Replacement	
5	004012	Rear side panels - Replacement	
6	004059	Spark plug inspection flap - Replacement	

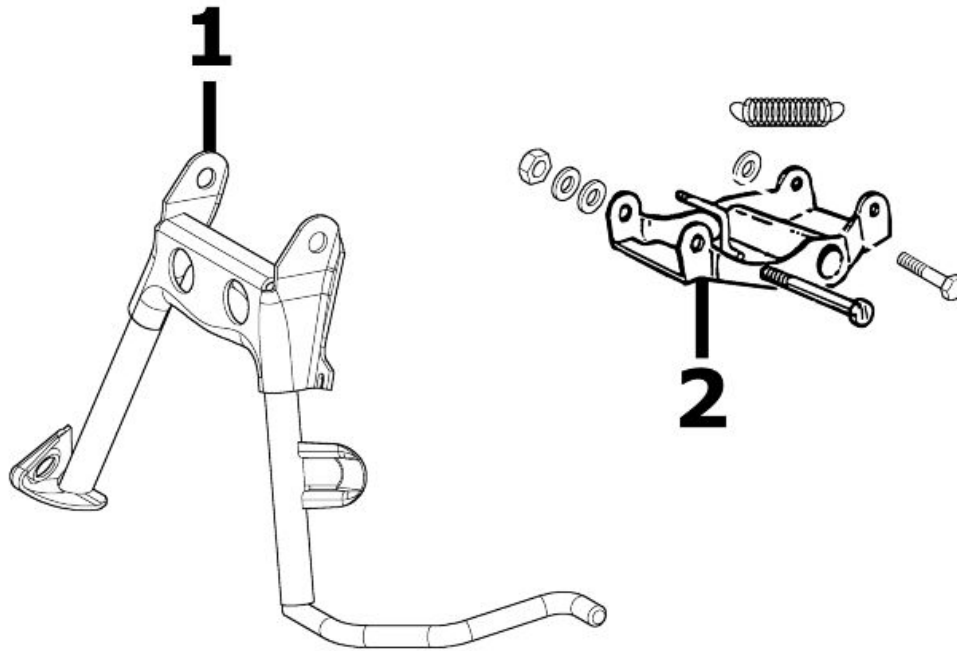
Centre-stand

	Code	STAND Action	Duration
1	004004	Stand - Replacement	
2	004171	Stand support plate - Replacement	

Footrests

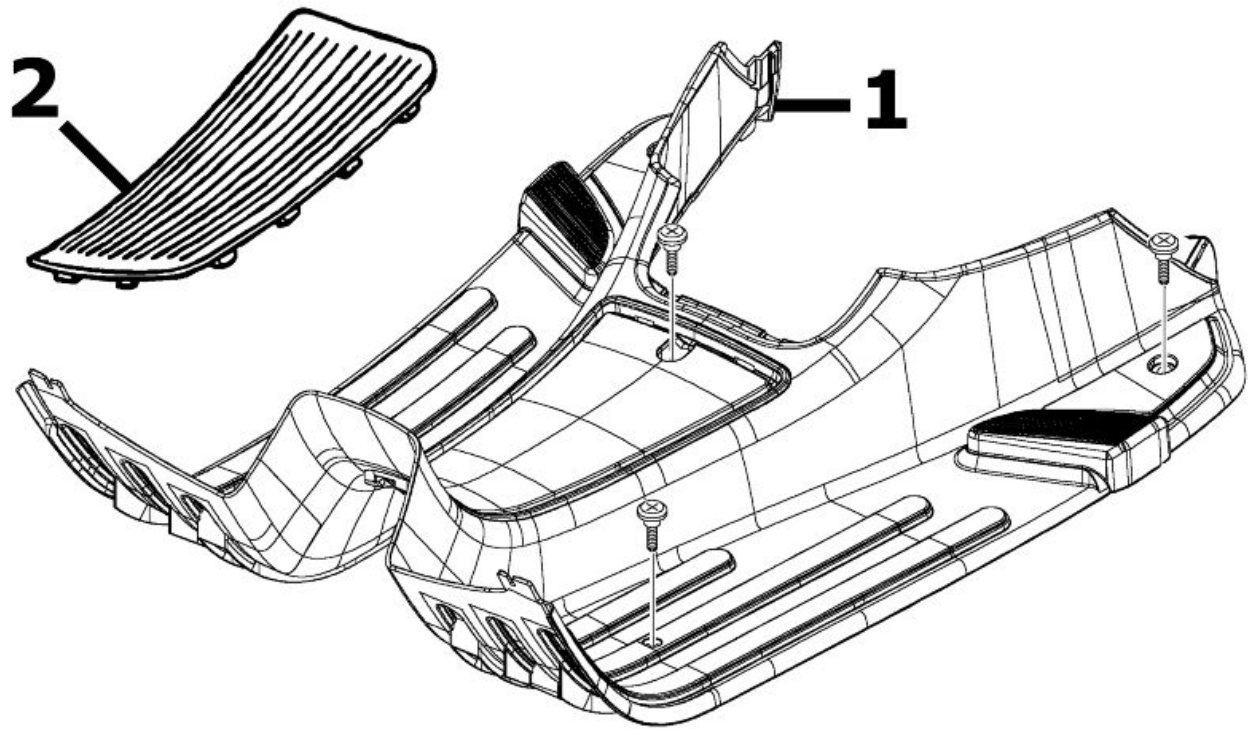

<u>FOOTREST</u>			
	Code	Action	Duration
1	004178	Footrest - Replacement	
2	004078	Front/rear footrest rubber - Replacement	

Rear cover

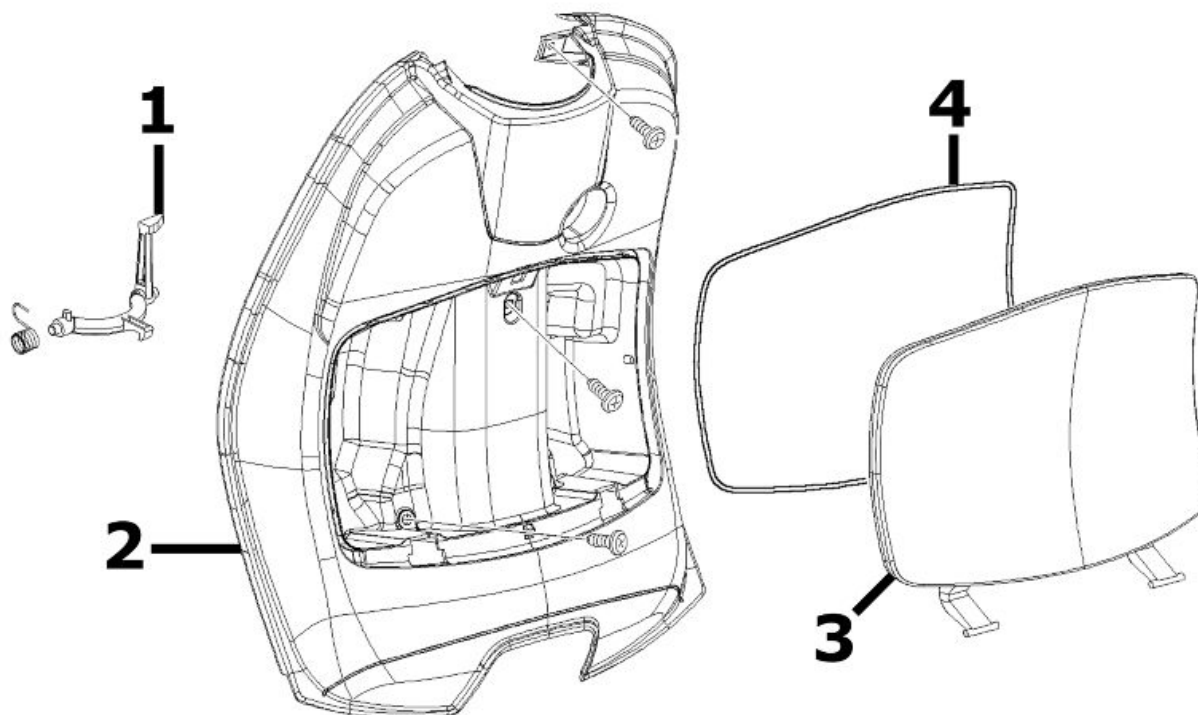
**SHIELD BACK PLATE**

	Code	Action	Duration
1	004174	Trunk levers - Replacement	
2	004065	Front shield, rear part - Removal and refitting	
3	004081	Glove box door - Replacement	
4	004082	Trunk gasket - Replacement	

Underseat compartment

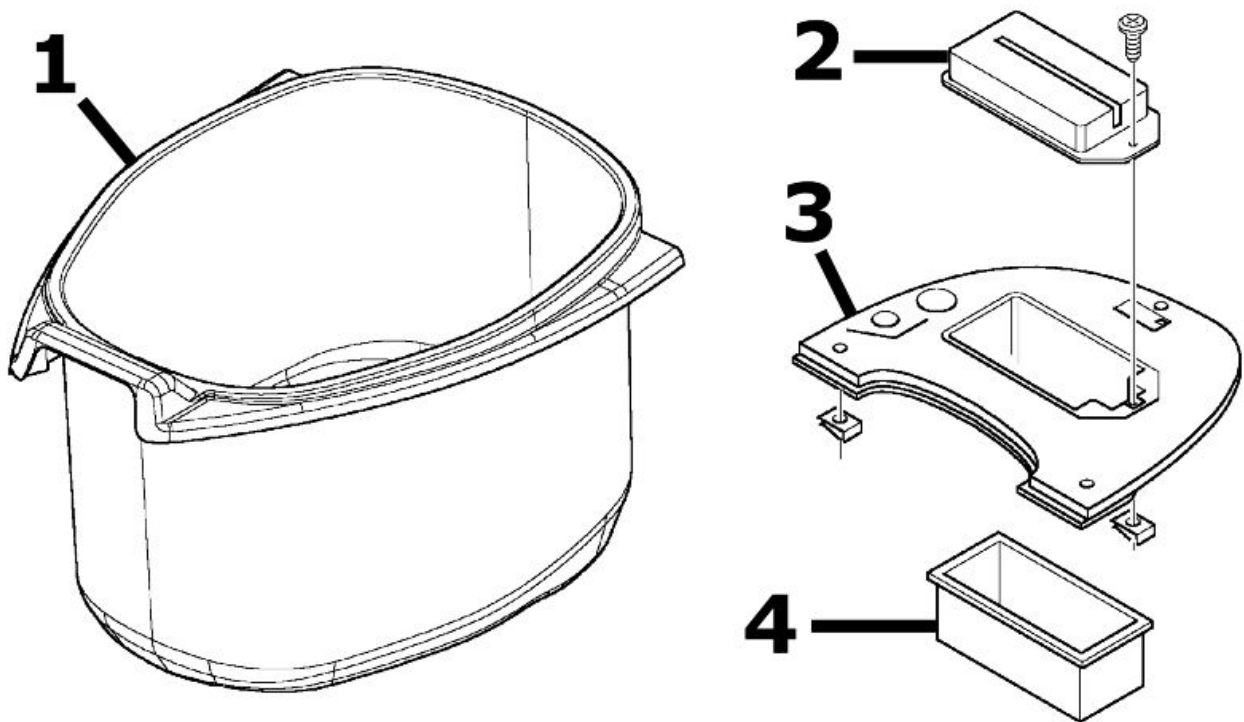
**HELMET COMPARTMENT**

	Code	Action	Duration
1	004016	Helmet compartment - Replacement	
2	005046	Battery cover - change	
3	004011	Central chassis cover - Replacement	
4	004071	Battery compartment - replacement	

Plate holder

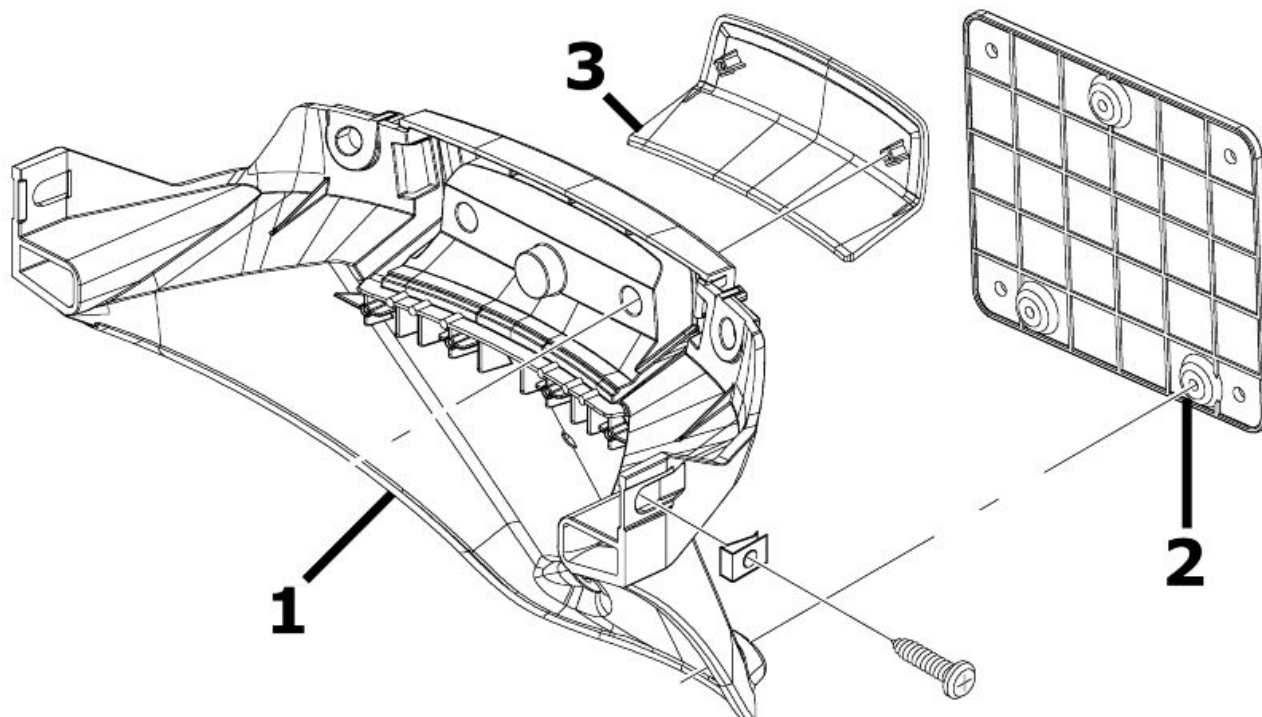

LICENSE PLATE HOLDER

	Code	Action	Duration
1	004136	License plate support - Replacement	
2	005048	Licence plate holder - Replacement	
3	005032	Transparent licence plate cover - replace	

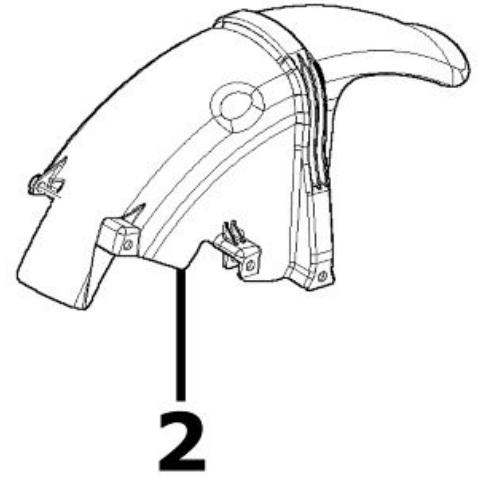
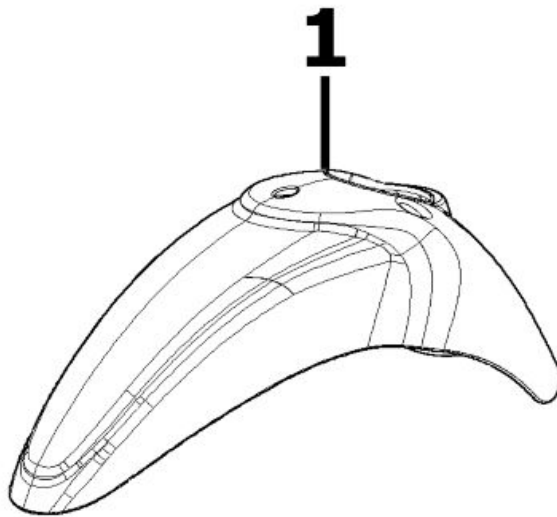
Mudguard**MUDGUARDS**

	Code	Action	Duration
1	004002	Front mudguard - Replacement	
2	004009	Rear mudguard - Replacement	

Fuel tank

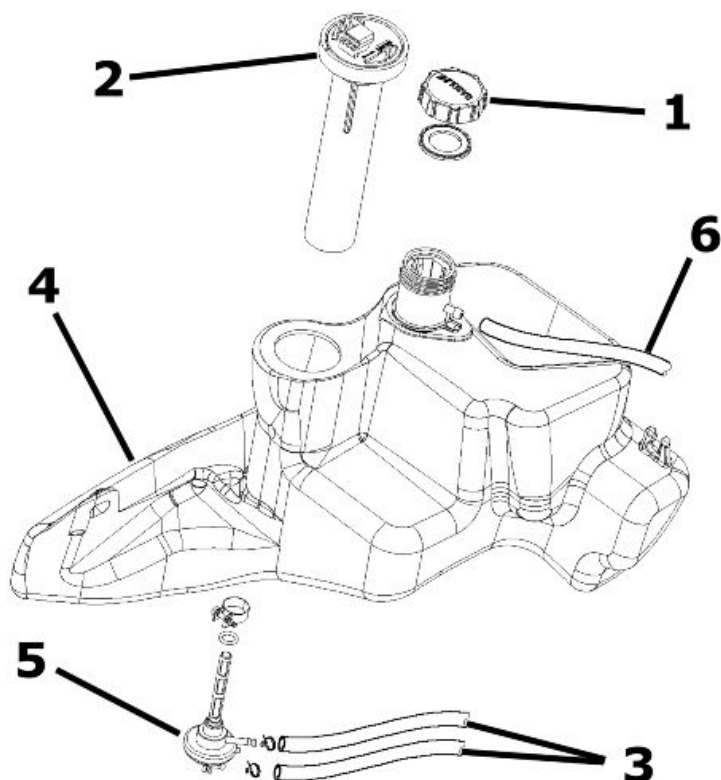
**FUEL TANK**

	Code	Action	Duration
1	004168	Fuel tank cap - Replacement	
2	005010	Tank float - Replacement	
3	004112	Cock-carburettor hose - Replacement	
4	004005	Fuel tank - Replacement	
5	004007	Fuel valve - Replacement	
6	004109	Fuel tank breather - Replacement	

Rear shock-absorber

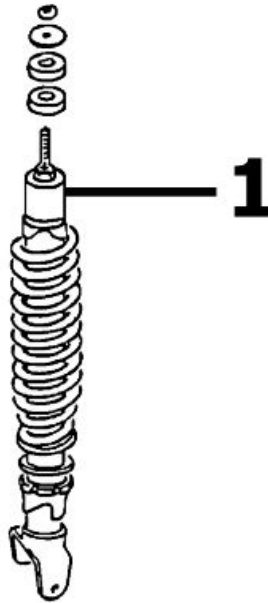
**REAR SHOCK ABSORBER**

	Code	Action	Duration
1	003007	Rear shock absorber - Removal and Refitting	

Steering column bearings

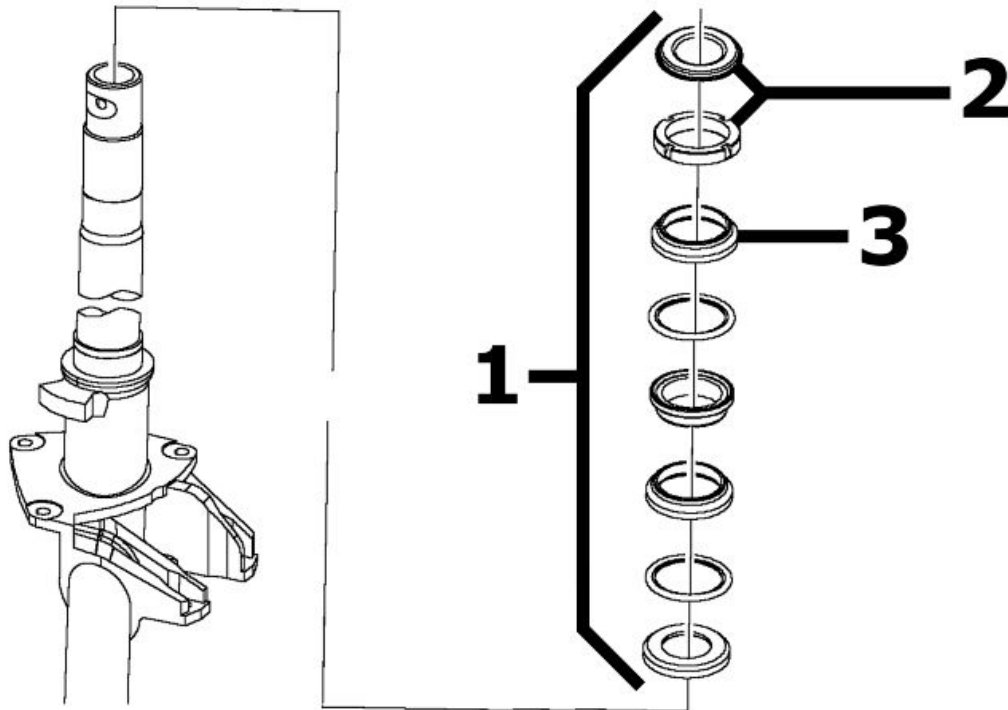

STEERING FIFTH WHEELS

	Code	Action	Duration
1	003002	Steering fifth wheel - Replacement	
2	003073	Steering clearance - Adjustment	
3	004119	Bearing / upper steering fifth wheel - Replacement	

Handlebar covers

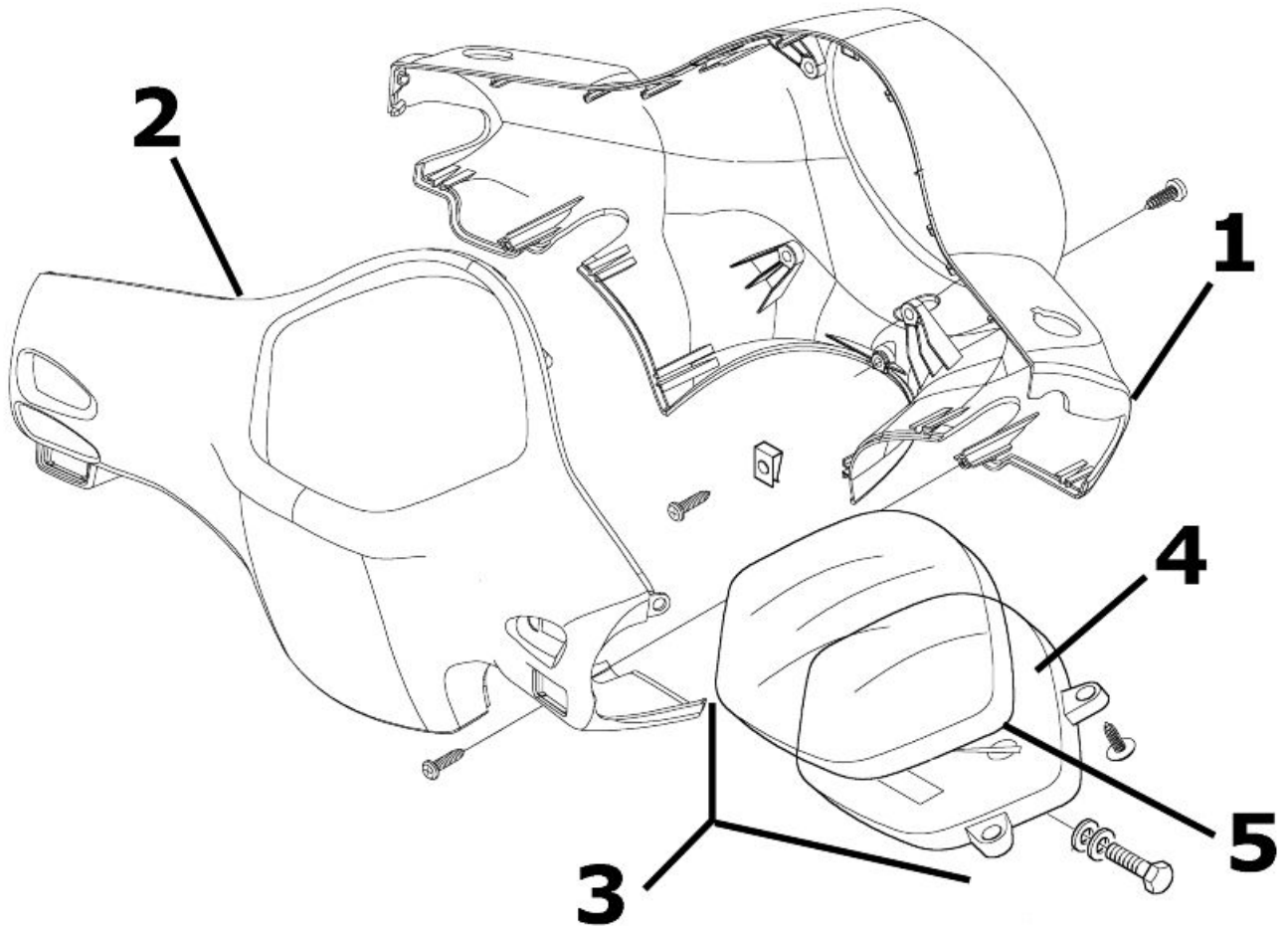

SPEEDOMETER - HANDLEBAR COVERS

	Code	Action	Duration
1	004018	Handlebar front section - Replacement	
2	004019	Handlebar rear section - Replacement	
3	005014	Odometer - Replacement	
4	005038	Instrument panel warning light bulbs - Replacement	
5	005078	Odometer glass - Replacement	

Handlebar components

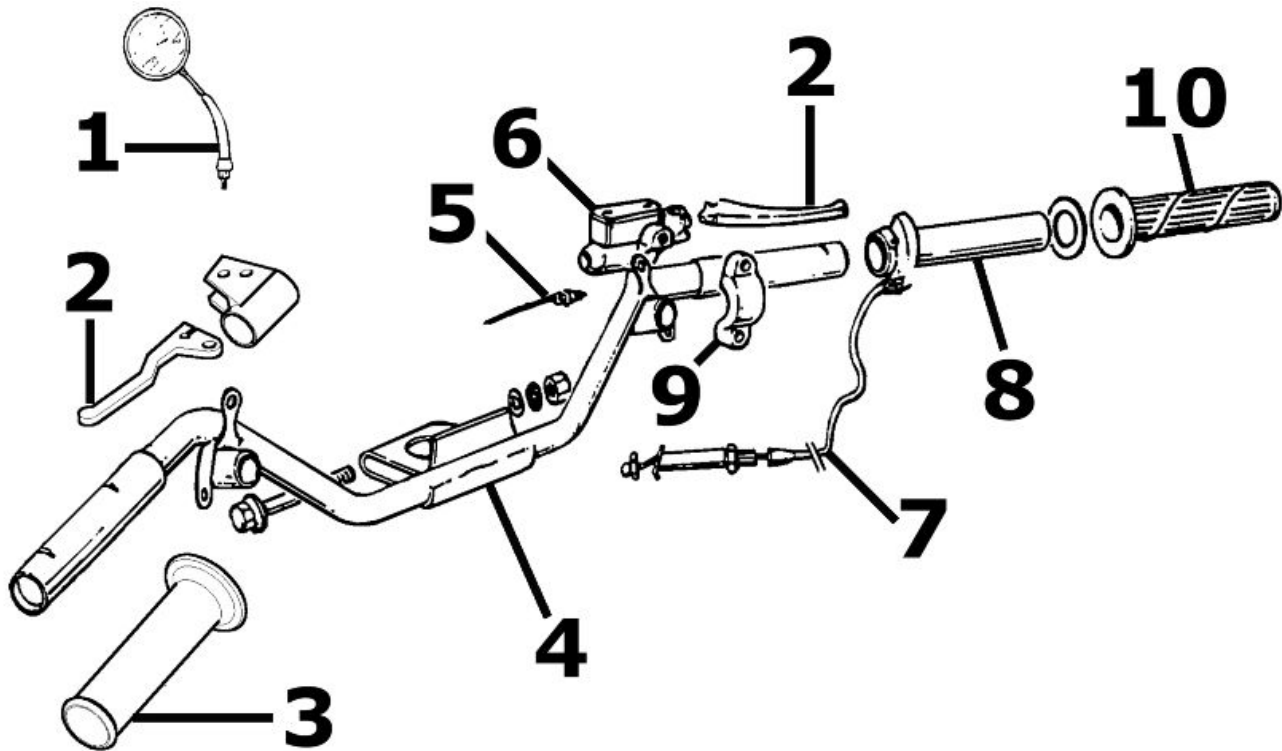

HANDLEBAR COMPONENTS

	Code	Action	Duration
1	004066	Driving mirror - Replacement	
2	002037	Brake or clutch lever - Replacement	
3	002071	Left hand grip - Replacement	
4	003001	Handlebar - Replacement	
5	005017	Stop switch - Replacement	
6	002024	Front brake pump - Removal and Refitting	
7	002063	Throttle control transmission - Replacement	
8	002060	Complete throttle control - Replacement	
9	004162	Mirror support and/or brake pump fitting U-bolt - Replacement	
10	002059	Right hand grip - Replacement	

Swing-arm

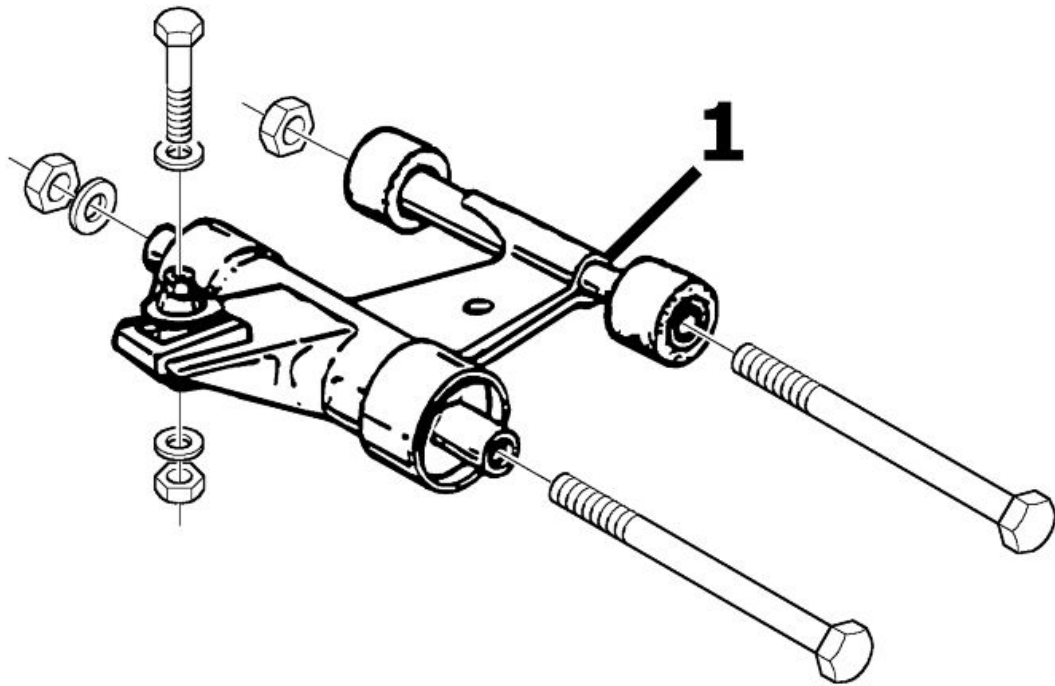

SWINGING ARM

	Code	Action	Duration
1	001072	Swinging arm - Engine-chassis connection - Replacement	

Seat

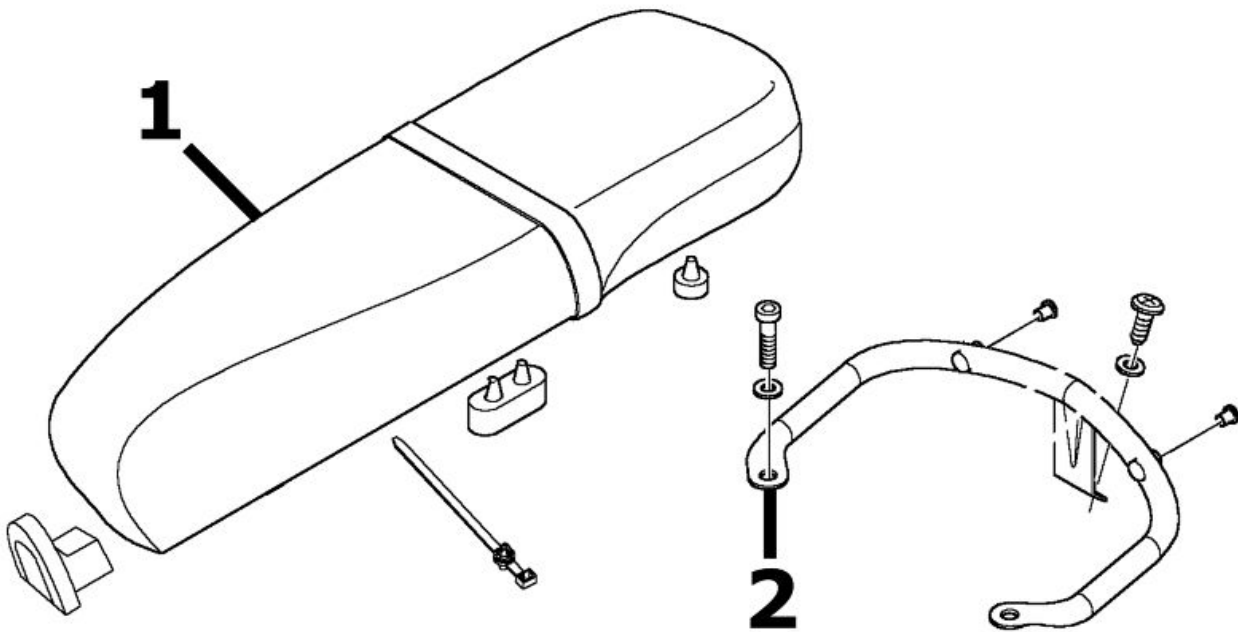
**SADDLE**

	Code	Action	Duration
1	004003	Saddle - Replacement	
2	004131	Luggage rack support - Replacement	

Turn signal lights

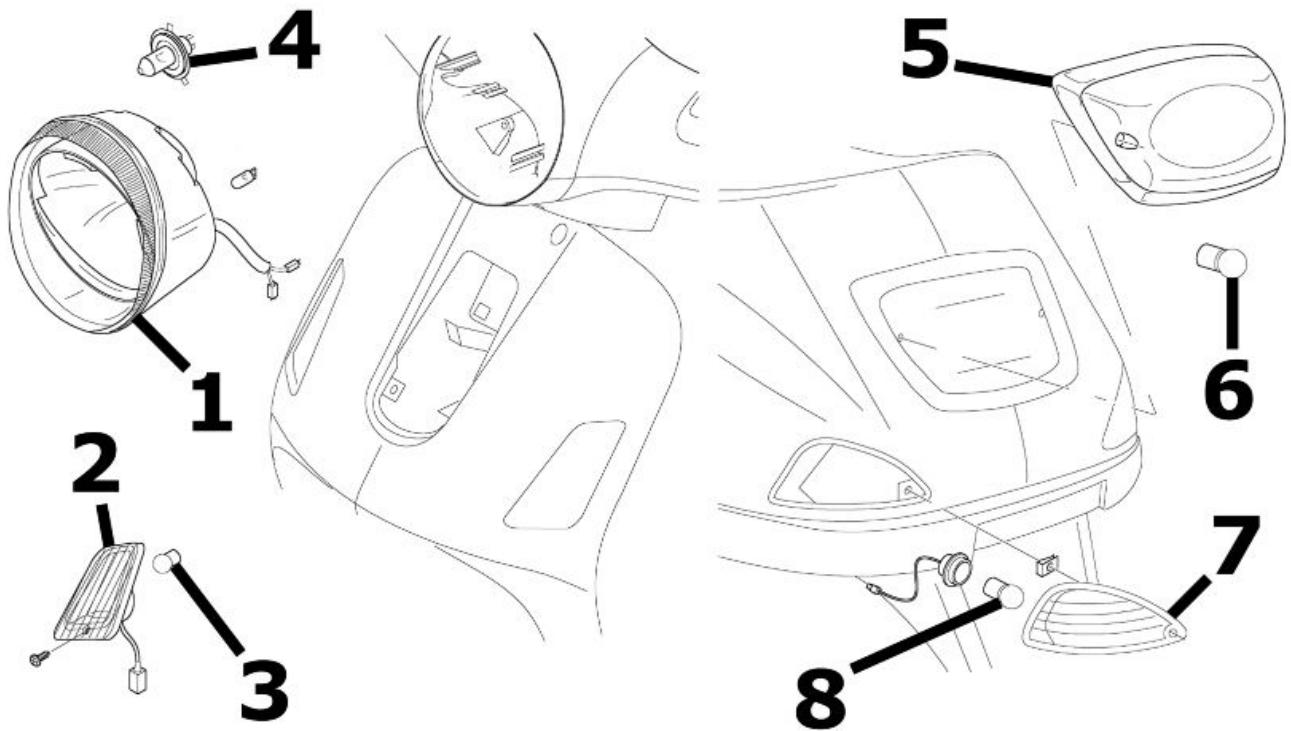

INDICATORS AND LIGHTS

	Code	Action	Duration
1	005002	Front headlamp - change	
2	005012	Front turn indicator - Replacement	
3	005067	Front turn indicator bulb - Replacement	
4	005008	Front headlamp bulbs - Replacement	
5	005005	Taillight - Replacement	
6	005066	Rear light bulbs - Replacement	
7	005022	Rear turn indicators - Replacement	
8	005068	Rear turn indicator bulb - Replacement	

Front wheel

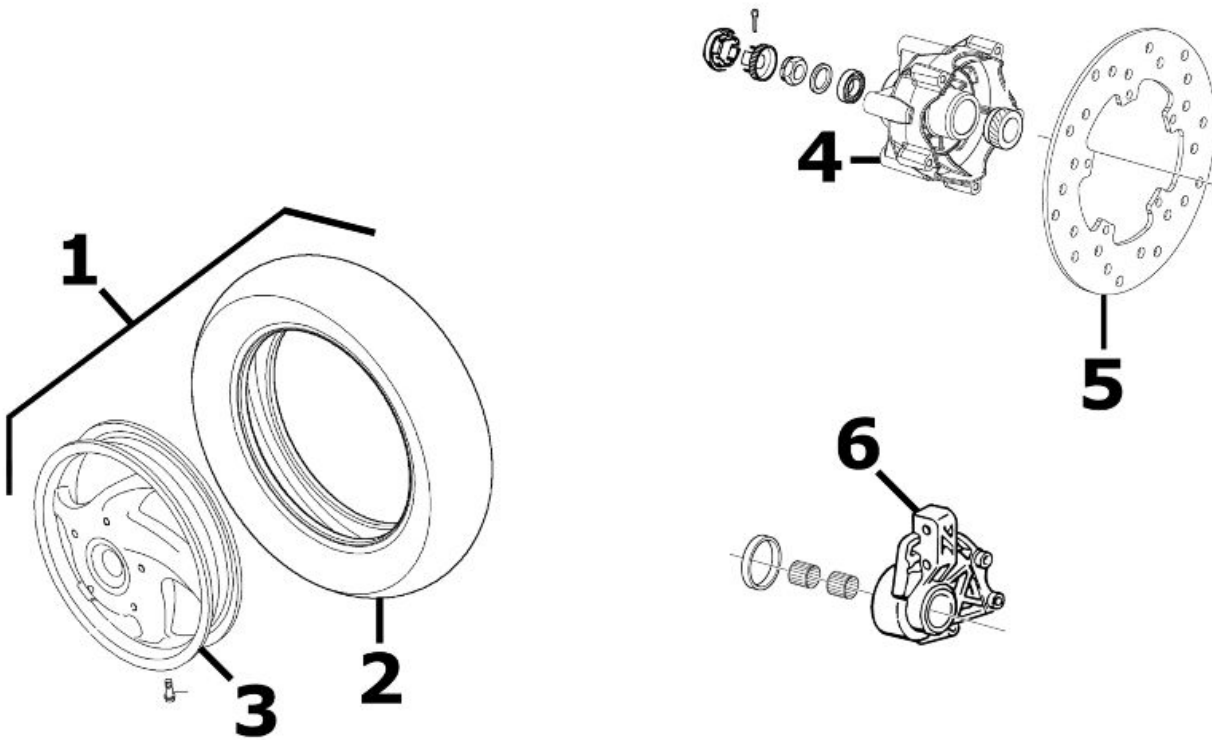

FRONT WHEEL

	Code	Action	Duration
1	004123	Front wheel - Replacement	
2	003047	Front tyre - Replacement	
3	003037	Front wheel rim- Replacement	
4	003033	Front wheel hub- Replacement	
5	002041	Front brake disc - Replacement	
6	003034	Front wheel hub bearing - Replacement	

Rear wheel

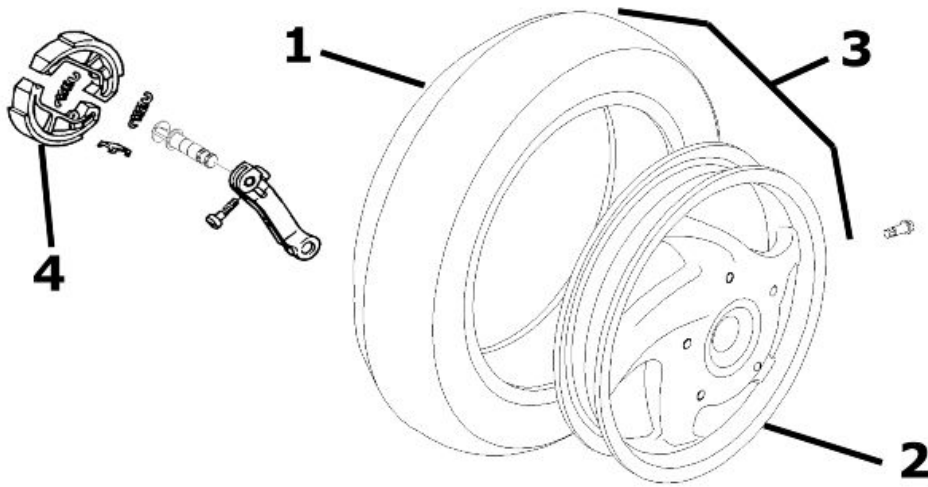

REAR WHEEL

	Code	Action	Duration
1	004126	Rear wheel tyre - Replacement	
2	001071	Rear wheel rim - Removal and Refitting	
3	001016	Rear wheel - Replacement	
4	002002	Rear brake pads/shoes - Replacement	

Electric devices

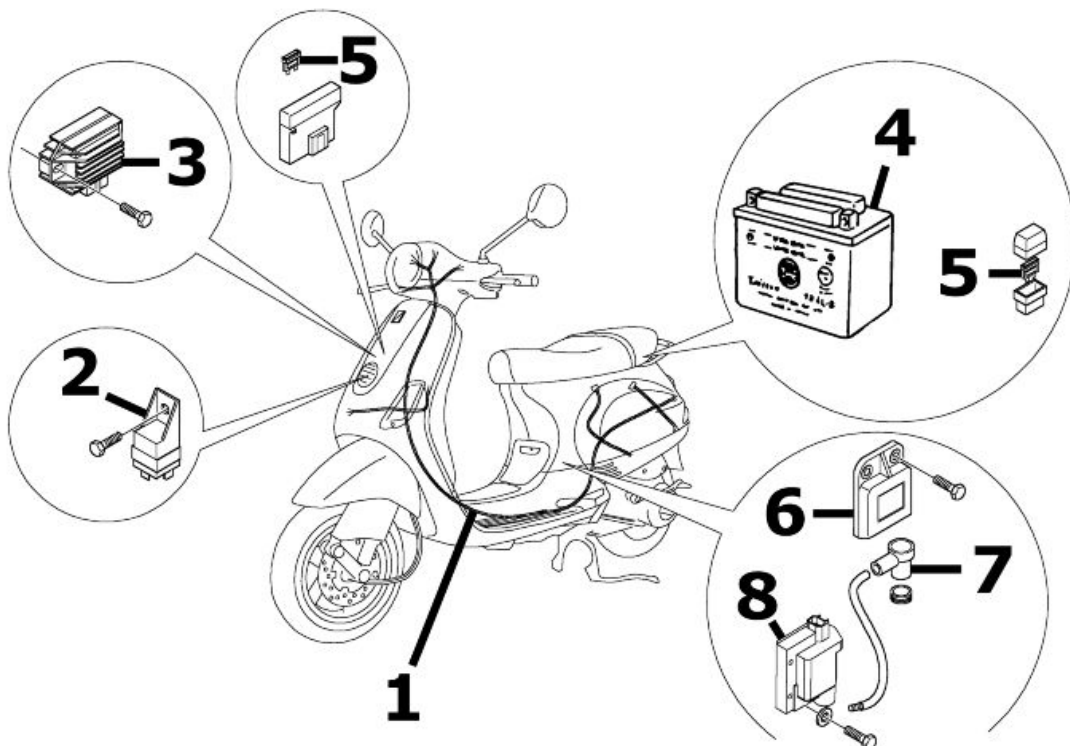

ELECTRICAL COMPONENTS

	Code	Action	Duration
1	005001	Electrical system - Replacement	
2	005011	Start-up remote control switch - Replacement	
3	005009	Voltage regulator - replace	
4	005007	Battery - Replacement	
5	005052	Fuse (1) - Replacement	
6	001023	Control unit - Replacement	
7	001094	Spark plug cap - Replacement	
8	001069	HV coil - replace	

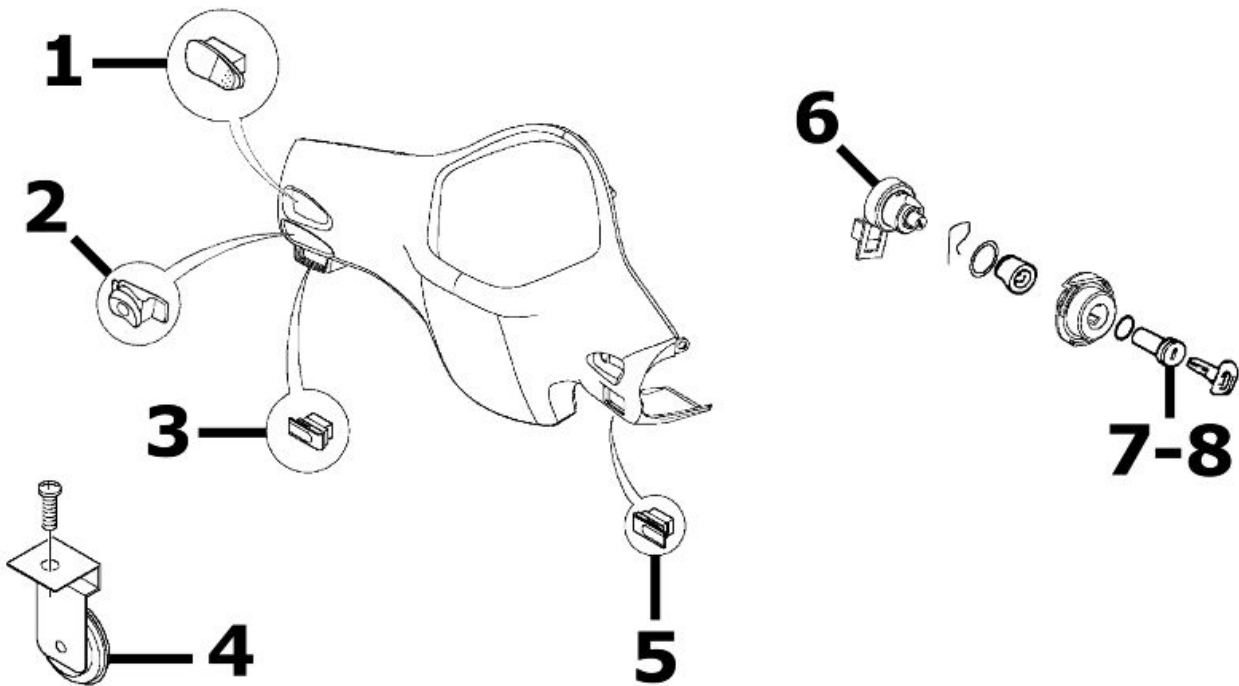
Electronic controls**ELECTRICAL CONTROLS**

	Code	Action	Duration
1	005039	Headlight switch - replace	
2	005006	Light switch or turn indicators - Replacement	
3	005040	Horn button - Replacement	
4	005003	Horn - Replacement	
5	005041	Starter button - Replacement	
6	005016	Key switch - Replacement	
7	004096	Lock series - Replacement	
8	004010	Anti-theft lock - Replacement	

Transmissions

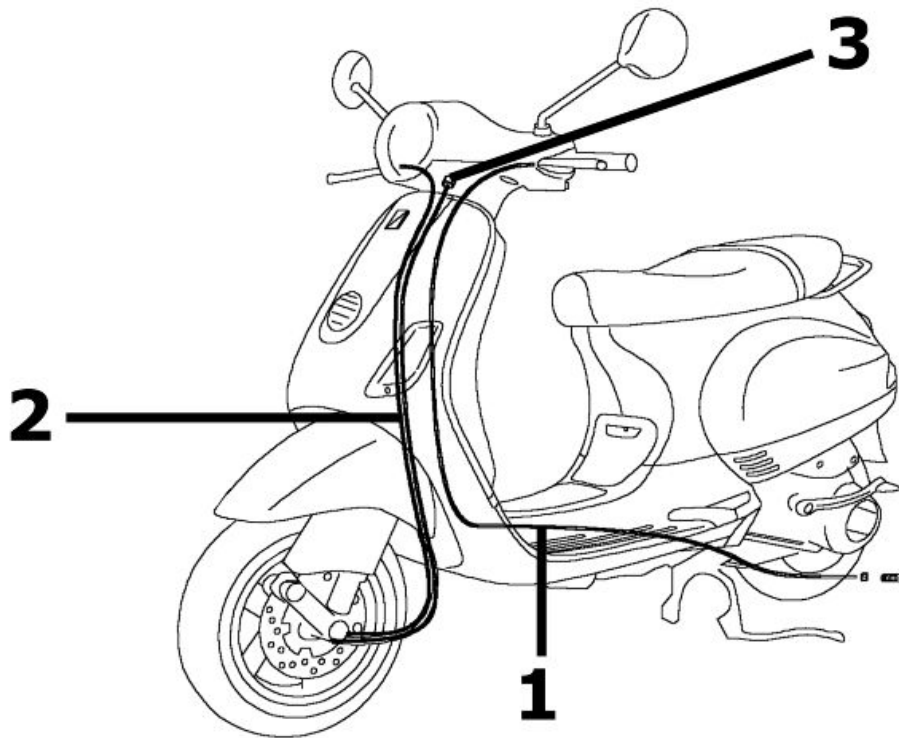

TRANSMISSIONS

	Code	Action	Duration
1	002053	Rear brake transmission complete - Replacement	
2	002051	Odometer transmission assembly - Replacement	
3	002049	Odometer cable - Replacement	

Front suspension

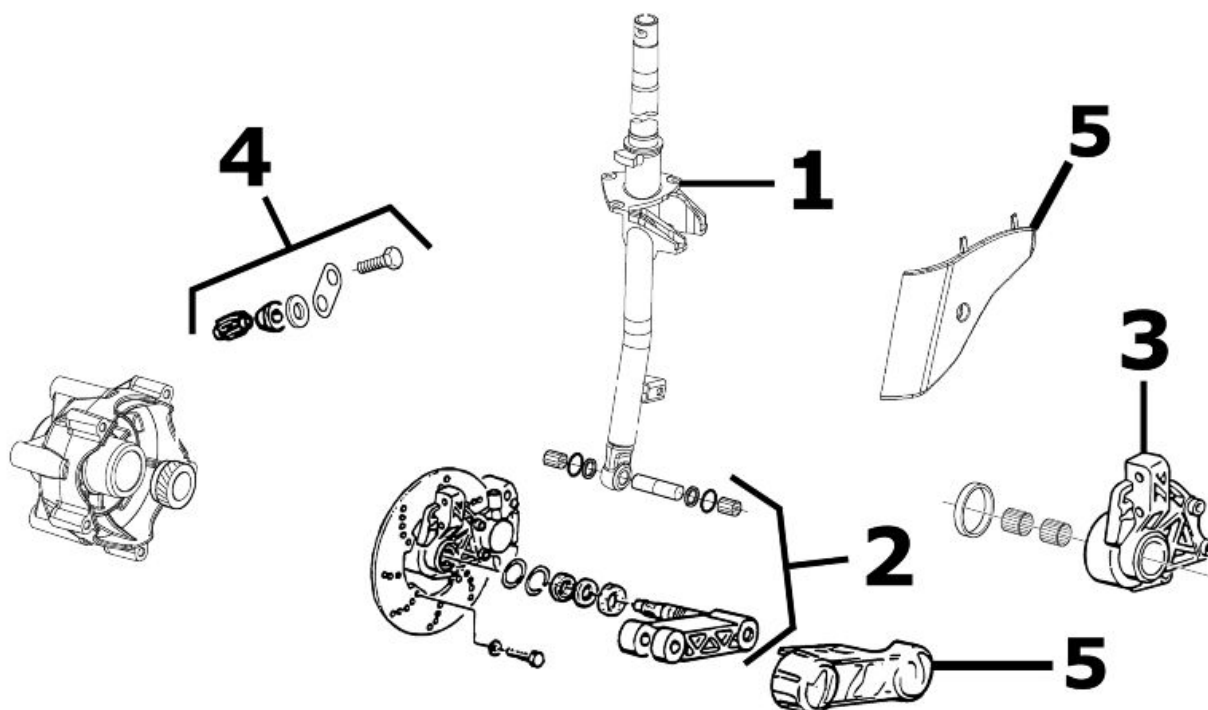

FRONT SUSPENSION

	Code	Action	Duration
1	003045	Steering tube - Replacement	
2	003010	Front suspension - Service	
3	003035	Shock absorber support and brake calliper - Replacement	
4	001064	Odometer reel - Replacement	
5	003044	Shock absorber cover - Replacement	

Braking system

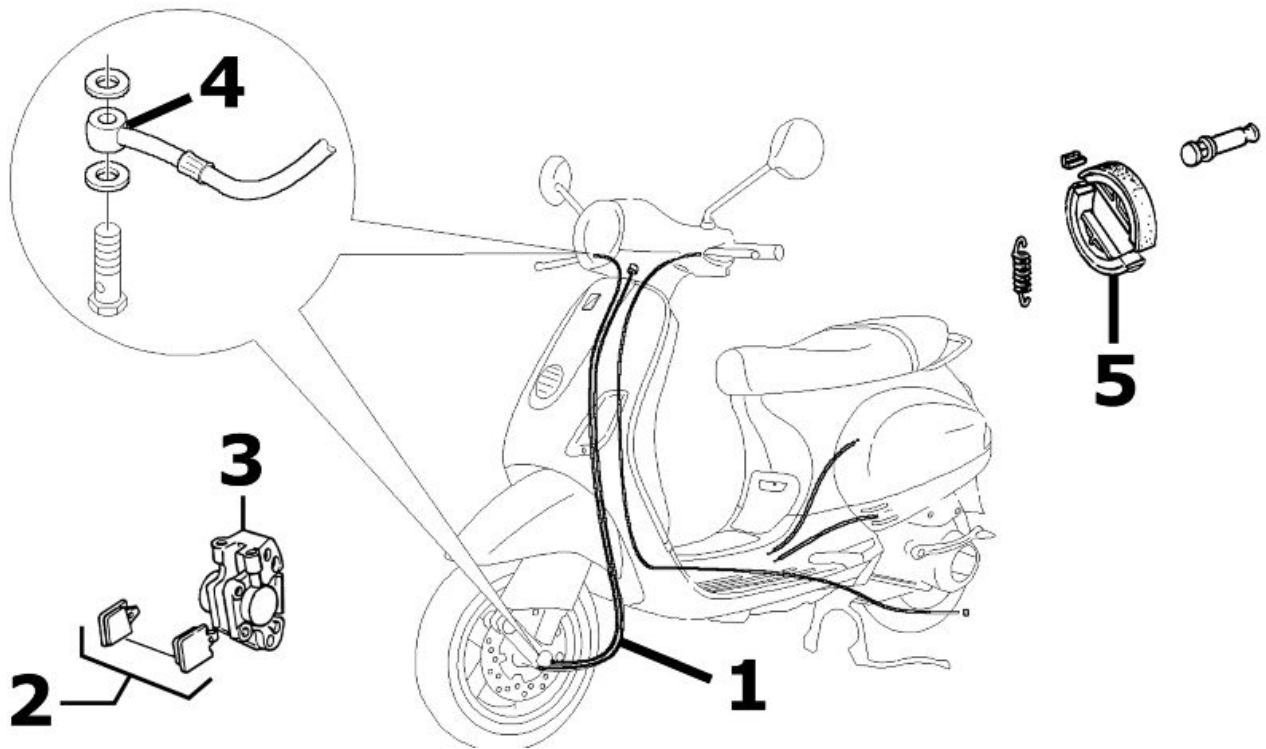

BRAKING SYSTEM

	Code	Action	Duration
1	002021	Front brake hose - Remov. and Refitt.	
2	002007	Front brake shoes/pads - Remov. and Refitt	
3	002039	Front brake calliper - Removal and Refitting	
4	002047	Front brake fluid and air bleeding system - Replacement	
5	002002	Shoes - Rear brake pads - Replacement	

Secondary air box

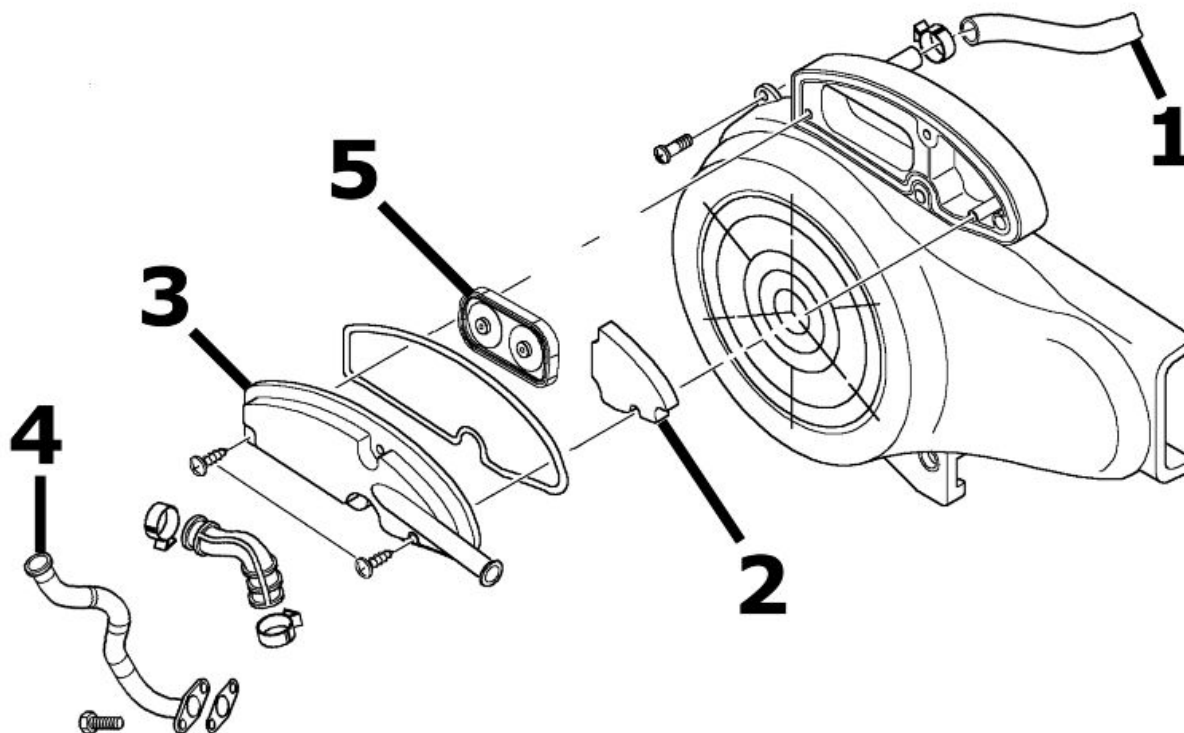

SECONDARY AIR HOUSING

	Code	Action	Duration
1	001164	Crankcase secondary air connection - Replacement	
2	001161	Secondary air filter - Replacement / Cleaning	
3	001162	Secondary air housing - Replacement	
4	001163	Muffler secondary air connection - Replacement	
5	001165	Secondary air reed - Replacement	