



---

# WORKSHOP MANUAL

---

633571

---



LX 4T USA

---



# WORKSHOP MANUAL

## LX 4T USA

The descriptions and illustrations supplied in this publication are not binding. PIAGGIO therefore reserves the right to make any changes to pieces, parts or accessory supplies, which it believes to be appropriate for improvement purposes or any requirement of a constructive or commercial nature, at any time, without the obligation to up-dating this publication before time, the essential characteristics of the type described and illustrated here remaining valid.

Not all versions reported in this publication are available in all Countries. The availability of single versions should be checked at the official Piaggio sales network.

"© Copyright 2005 - PIAGGIO & C. S.p.A. Pontedera. All rights reserved. No part of this publication may be reproduced."

PIAGGIO & C. S.p.A. - Q.C.S./ After Sale Service V.le Rinaldo Piaggio, 23 - 56025 Pontedera (PI)  
[www.piaggio.com](http://www.piaggio.com)

---

---

# WORKSHOP MANUAL

## LX 4T USA

This workshop manual has been drawn up by Piaggio & C. Spa to be used by the workshops of Piaggio-Gilera dealers. This manual is addressed to Piaggio service mechanics who are supposed to have a basic knowledge of mechanics principles and of vehicle fixing techniques and procedures. Any important changes made to the vehicles or to specific fixing operations will be promptly reported by updates to this manual. Nevertheless, no fixing work can be satisfactory if the necessary equipment and tools are unavailable. It is therefore advisable to read the sections of this manual relating to specific tools, along with the specific tool catalogue.

**N.B.** Provides key information to make the procedure easier to understand and carry out.

**CAUTION** Refers to specific procedures to carry out for preventing damages to the vehicle.

**WARNING** Refers to specific procedures to carry out to prevent injuries to the repairer.



**Personal safety** Failure to completely observe these instructions will result in serious risk of personal injury.



**Safeguarding the environment** Sections marked with this symbol indicate the correct use of the vehicle to prevent damaging the environment.



**Vehicle intactness** The incomplete or non-observance of these regulations leads to the risk of serious damage to the vehicle and sometimes even the invalidity of the guarantee.



---

---



## INDEX OF TOPICS

CHARACTERISTICS

CHAR

TOOLING

TOOL

MAINTENANCE

MAIN

TROUBLESHOOTING

TROUBL

ELECTRICAL SYSTEM

ELE SYS

ENGINE FROM VEHICLE

ENG VE

ENGINE

ENG

SUSPENSIONS

SUSP

BRAKING SYSTEM

BRAK SYS

CHASSIS

CHAS

PRE-DELIVERY

PRE DE

TIME

TIME



## INDEX OF TOPICS

CHARACTERISTICS

CHAR

---

## Rules

---

### Safety rules

- Should it be necessary to keep the engine running while servicing, make sure that the area or room is well ventilated, and use special exhaust fans, if required. Never let the engine running in closed rooms. In fact, exhaust gases are toxic.
  - The battery electrolyte contains sulphuric acid. Protect your eyes, cloths and skin. Sulphuric acid is highly corrosive; in the event of contact with your eyes or clothes, rinse thoroughly with water and consult a doctor immediately.
  - The battery produces hydrogen, a gas that can be highly explosive. Do not smoke and avoid sparks and flames when close to the battery, especially during recharge.
  - Fuel is highly flammable, and in some conditions it can be explosive. Do not smoke in the working area, and avoid free flames or sparks.
  - Clean the brake pads in a well ventilated environment, directing the compressed air jet so as to not intake the dust produced by the wear of the friction material. Even though the latter contains no asbestos, dust inhalation is harmful.
- 

### Maintenance rules

- Use original PIAGGIO spare parts and lubricants recommended by the Manufacturer. Non-original or non-conforming spares may damage the vehicle.
  - Use only the specific tools designed for this vehicle.
  - Always use new gaskets, sealing rings and split pins upon reassembly.
  - After removal, clean the components using non-flammable or low fire-point solvent. Lubricate all working surfaces before reassembly, except for conical couplings.
  - After reassembly, check that all components have been installed properly and that they are in good working order.
  - For removal, overhaul and reassembly operations use only tools provided with metric measures. Metric bolts, nuts and screws are not interchangeable with coupling members with English measurement. Using improper coupling members and tools may impair the vehicle.
  - Should any interventions to the vehicle electric system be required, check that the electrical connections - especially earth and battery connections - have been implemented properly.
- 

### Vehicle identification

---

**VEHICLE IDENTIFICATION**

Specification	Desc./Quantity
Chassis prefix	ZAPC38300 ÷ 1001
Engine prefix	M383M÷1001

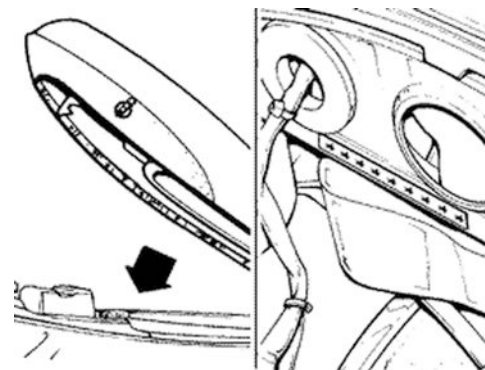
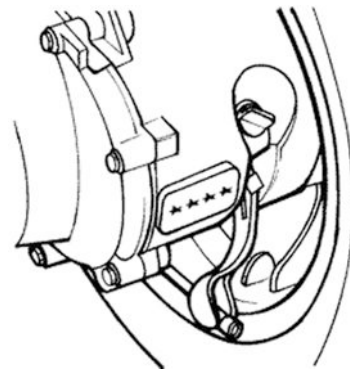

**Dimensions and mass**

**WEIGHT AND DIMENSIONS**

Specification	Desc./Quantity
Dry weight	102 ± 5
Width	740 mm
Length	1755 mm
Wheel base	1290 mm.
Maximum height	1140 mm.

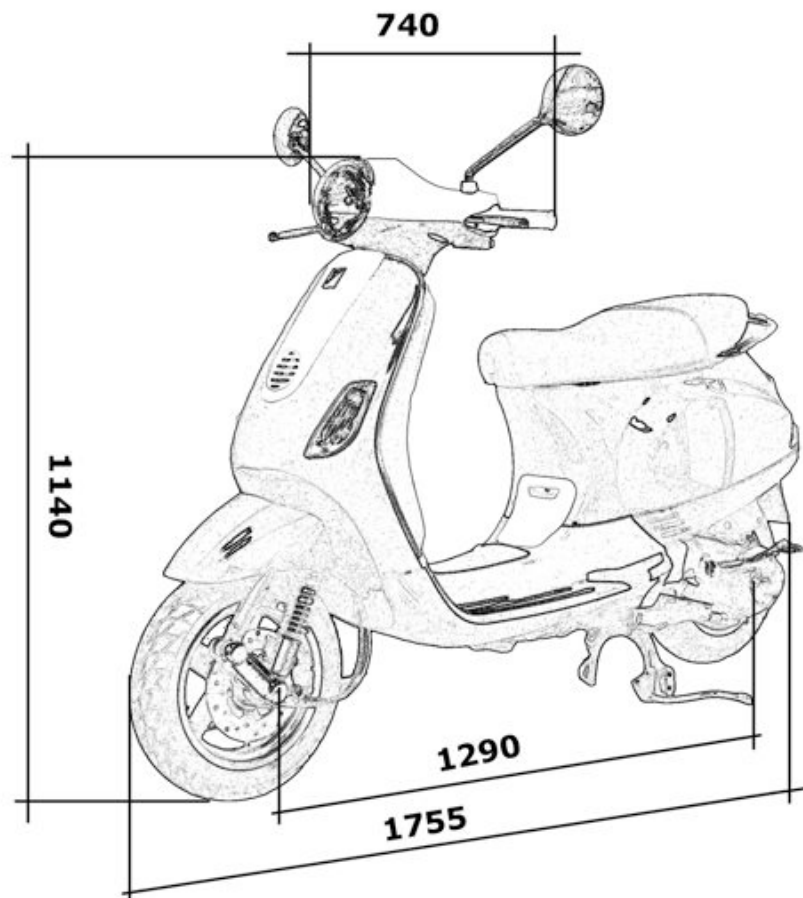

**Engine**

**ENGINE**

Specification	Desc./Quantity
Type	Single-cylinder, 4-stroke, Piaggio Hi-Per 4
Bore	39 mm
Stroke	41,8 mm
Displacement	49,93 cm <sup>3</sup>
Compression ratio	11,5 ÷ 12 : 1
Timing system	overhead single camshaft, two valves, chain-controlled on l.h. side.
Vacuum-type carburettor	KEIHIN CVK Ø 18 mm
CO Adjustment	3,2% ± 0,5
Engine idle speed	1900 ÷ 2000 rpm
Air filter	Sponge, impregnated with mixture (50% Selenia Air Filter Oil and 50% lead-free fuel).
Starter system	starter motor/kick-start.
Lubrication	of the engine with chain-controlled lobe pump

Specification	Desc./Quantity
	(inside the crankcase). Net prefilter and centrifugal filter obtained on the driving shaft.
Fuel system	Gravity, unleaded petrol (minimum octane number 95), through carburettor.
Max. power (crankshaft)	2,5 KW (3,4 CV) at 6500 rpm.
Cooling system	forced air
Valves play (cold)	induction 0.10 mm exhaust 0.15 mm

## Transmission

### TRASMISSIONS

Specification	Desc./Quantity
Transmission	Expanding pulley type automatic speed variator with vee belt, automatic clutch and gear final drive.

## Capacities

### CAPACITY

Specification	Desc./Quantity
Fuel tank (including 2 litre reserve)	~ 8,5 l
Rear hub oil	85 cc
Engine oil	~850 cc

## Electrical system

### ELECTRICAL SYSTEM:

Specification	Desc./Quantity
Ignition type	capacitive discharge electronic ignition with incorporated high-voltage coil.
Ignition advance variable, with microprocessor (before T.D.C.)	8° at 1000 + 2000 rpm - 21° at 4000 + 7000 rpm
Spark plug	NGK CR 8EB
Battery	12V-9Ah
Fuse	10A
Generator	AC current, single-phase.

## Frame and suspensions

**FRAME AND SUSPENSION**

Specification	Desc./Quantity
Type	Structural frame in pressed sheet steel.
Front suspension	Single-arm with swinging hub pivoting on steering tube. Double-acting hydraulic shock absorber with coaxial spring.
Front suspension stroke	70 mm
Trail (unloaded/loaded suspension)	71/68 mm
Rear suspension	Single double-acting hydraulic shock absorber with coaxial spiral spring. Engine-frame mount by swinging arm.
Rear suspension travel:	83,5 mm

**Brakes****Wheels and tyres****WHEELS AND TYRES**

Specification	Desc./Quantity
Front tyre dimensions	110/70"-11"
Rear tyre dimension	120/70-10"
Front tyre inflation pressure:	1,6 bar
Rear tyre inflation pressure:	2 bar
Light alloy rims (front)	2,50" x 11"
Lightweight alloy wheels (rear)	3,00 x 10"

N.B.

**CHECK AND ADJUST TYRE PRESSURE WITH TYRES AT AMBIENT TEMPERATURE.  
ADJUST PRESSURE ACCORDING TO THE WEIGHT OF THE RIDER AND ACCESSORIES.**

**Carburettor****50cc Version****Kehin****KEHIN CARBURETTOR**

Specification	Desc./Quantity
Type	CVK 18



Specification	Desc./Quantity
Throttle valve diameter:	Ø 18,5
Choke diameter	Ø 17
Marking on body:	Z61B
Maximum thrust	75
Maximum air thrust (on body)	Ø1,1
Marking on conical needle:	NGBA
Throttle spring:	100 ÷ 159 gr
Minimum thrust	35
Idle air jet (on body):	Ø 1,4
Initial opening - idle mixture screw:	1 3/4
Starter jet	40
Starter air thrust (on body)	Ø 1,5
Choke needle travel:	11,5 mm

## Tightening Torques

### STEERING

Name	Torque in Nm
Steering upper collar	30 ÷ 40
Steering lower collar	8 ÷ 10
Handlebar fastening screw	50 ÷ 55 Nm

### FRAME ASSEMBLY

Name	Torque in Nm
Oscillating arm pin - engine	33 ÷ 41
Floating arm-frame pin	44 ÷ 52
Frame-rear shock absorber nut	20 ÷ 25
Shock absorber-engine nut	33 ÷ 41
Rear wheel nut	104 ÷ 126
Speedometer gear plate fixing screw	4 ÷ 6

### FRONT SUSPENSION

Name	Torque in Nm
Shock absorber upper nut	20 ÷ 30
Front wheel spindle nut	75 ÷ 90
Shock absorber upper bracket bolt	20 ÷ 25
Wheel rim screw	20 ÷ 25

Name	Torque in Nm
Shock absorber lower bolts (°)	20 ÷ 27

(°)Tighten these two bolts after tightening the shock absorber central upper nut.

**N.B.**

**FOR INFORMATION ON SAFETY TIGHTENINGS, REFER TO CHAPTER «PRE-CONSIGNMENT CHECKS».**

### **FRONT BRAKE**

Name	Torque in Nm
Pump-tube oil connection	8 ÷ 12
Tube-caliper oil connection	20 ÷ 25
Screw fixing the caliper to the support	20 ÷ 25
Brake disc screw	5 ÷ 6,5
Oil bleeder valve (on caliper)	10 ÷ 12
Handlebar to pump	7 ÷ 10

### **ENGINE ASSEMBLY**

Name	Torque in Nm
Spark plug:	10 ÷ 15 Nm
Screw fixing floating head	6 ÷ 7
Head-cylinder stud bolts	6 ÷ 7 + 90° + 90° *
Head and cylinder fixing screws to crankcase	8 ÷ 10
Chain-tensioning pad screw:	5 ÷ 7 Nm
Timing chain tensioner central screw:	5 ÷ 6 Nm
Camshaft pulley screw:	12 ÷ 14 Nm
Rocker-arm shaft and camshaft bearing screw:	3 ÷ 4 Nm
Rocker-arm adjusting nuts:	7 ÷ 9 Nm
Engine oil pre-filter cap:	25 ÷ 28 Nm
Engine oil drain plug	25 ÷ 28
Flywheel nut	40 ÷ 44 N.m
Stator screws	3 ÷ 4
Pick up screws	3 ÷ 4
Oil pump guard screw	4 ÷ 5
Oil pump/timing chain compartment cover screws	4 ÷ 5
Oil decantation labyrinth lamination screws	7 ÷ 8
Oil pump gear screw	8 ÷ 10
Screws fixing the oil pump to the crankcase	5 ÷ 6

Name	Torque in Nm
Tightening torque	8 ÷ 10 Nm
Oil pump to crankcase fixing screw	7 ÷ 9
Manifold/carburettor clamp screw	1,2 ÷ 1,5
Cables to starting motor fixing screw	1,5 ÷ 2,5
Starting motor screws	11 ÷ 13
Transmission cover screws	11 ÷ 13
Starting lever screw	11 ÷ 13
Cooling casing screw on crankcase	2 ÷ 2,5
Clutch assembly nut	55 ÷ 60
Tightening torque plus angle	18 ÷ 20 + 90° N.m
Driven pulley shaft nut	40 -÷ 44 Nm
Hub oil drain screw	3 ÷ 5 Nm
Rear hub cover screws	11 ÷ 13
Half crankcase coupling screw	8 ÷ 10

\*When new stud bolts are assembled, tighten them with 3 turns at 90° after the first tightening at 6-7 N·m, therefore 6-7 N·m + 90° + 90° + 90°, in a crosswise manner.

**Overhaul data**

**Assembly clearances**

**Cylinder - piston assy.**

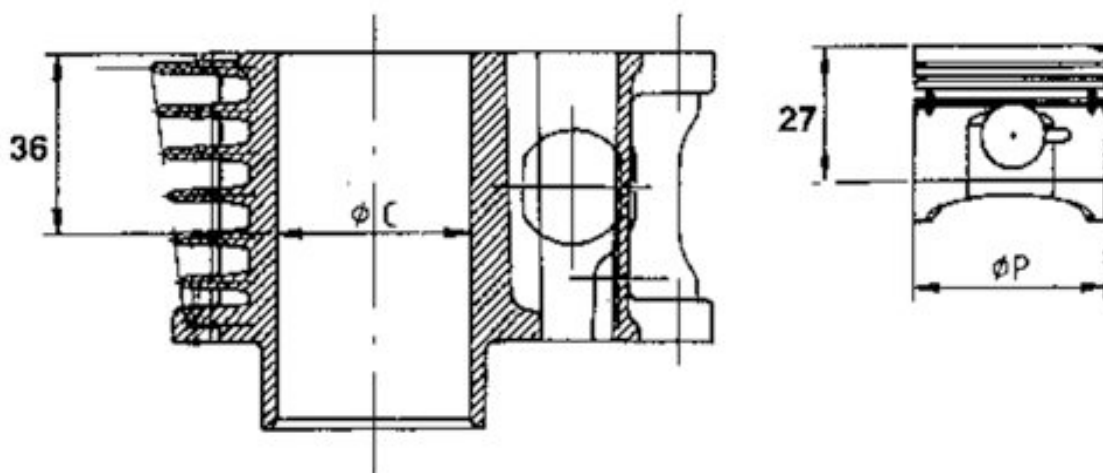

**CONNECTION PISTON AND CYLINDER**

Name	Play	Initials	Cylinder	Piston	Play on fitting
Cylinder (with asso piston/ right way)	39 +0.021-0.007	A	38,993 ÷ 39,000	38,954 ÷ 38,961	0.032 ÷ 0.046
Cylinder (with shiram piston)	39 +0.021-0.007	A	38,993 ÷ 39,000	38,949 ÷ 38,956	0.037 ÷ 0.051
Cylinder (with asso piston/ right way)	39 +0.021-0.007	B	39,000 ÷ 39,007	38,961 ÷ 38,968	0.032 ÷ 0.046
Cylinder (with shiram piston)	39 +0.021-0.007	B	39,000 ÷ 39,007	38,956 ÷ 38,966	0.037 ÷ 0.051
Asso piston/ right way (with asso cylinder/ right way)	38,968 ± 0,014	C	39,007 ÷ 39,014	38,968 ÷ 38,975	0,032 ÷ 0,046
Asso piston/ right way (with shiram cylin- der)	38,968 ± 0,014	C	39,007 ÷ 39,014	38,963 ÷ 38,970	0,037 ÷ 0,051
Shiram piston (with asso cyl- inder/right way)	38,963 ± 0,014	D	39,014 ÷ 39,021	38,975 ÷ 38,982	0,032 ÷ 0,046
Shiram piston (with shiram cylinder)	38,963 ± 0,014	D	39,014 ÷ 39,021	38,970 ÷ 38,977	0,037 ÷ 0,051
Cylinder first uprat.	39,2+0,021-0,0 07	A1	39,193 ÷ 39,200	39,154 ÷ 39,161	0,032 ÷ 0,046
Cylinder first uprat.	39,2+0,021-0,0 07	B1	39,200 ÷ 39,207	39,161 ÷ 39,168	0,032 ÷ 0,046
Piston first up- rat.	39,168 ± 0,014	C1	39,207 ÷ 39,214	39,168 ÷ 39,175	0,032 ÷ 0,046
Piston first up- rat.	39,168 ± 0,014	D1	39,214 ÷ 39,221	39,175 ÷ 39,182	0,032 ÷ 0,046
Cylinder second uprat.	39,2+0,021-0,0 07	A2	39,393 ÷ 39,400	39,354 ÷ 39,361	0,032 ÷ 0,046
Cylinder second uprat.	39,2+0,021-0,0 07	B2	39,400 ÷ 39,407	39,361 ÷ 39,368	0,032 ÷ 0,046
Piston second uprat.	39,368 ± 0,014	C2	39,407 ÷ 39,414	39,368 ÷ 39,375	0,032 ÷ 0,046
Piston second uprat.	39,368 ± 0,014	D2	39,414 ÷ 39,421	39,375 ÷ 39,382	0,032 ÷ 0,046
Cylinder third uprat.	39,6+0,021-0,0 07	A3	39,593 ÷ 39,600	39,554 ÷ 39,561	0,032 ÷ 0,046

Name	Play	Initials	Cylinder	Piston	Play on fitting
Cylinder third uprat.	39,6+0,021-0,007	B3	39,600 ÷ 39,607	39,561 ÷ 39,568	0,032 ÷ 0,046
Piston third uprat.	39,568 ± 0,014	C3	39,607 ÷ 39,614	39,568 ÷ 39,575	0,032 ÷ 0,046
Piston third uprat.	39,568 ± 0,014	D3	39,614 ÷ 39,621	39,575 ÷ 39,582	0,032 ÷ 0,046

## Piston rings

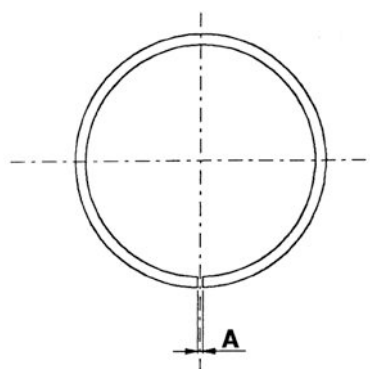

### UPRATING TABLE

Name	Description	Dimensions	Initials	Quantity
1° Compression lining		39 x 1	A	0,08 ÷ 0,20
2° Compression lining		39 x 1	A	0,05 ÷ 0,20
Scrapper ring lining		39 x 2	A	0,20 ÷ 0,70
1° Compression lining 1° greater		39,2 x 1	A	0,08 ÷ 0,20
2° Compression lining 1° greater		39,2 x 1	A	0,05 ÷ 0,20
Scrapper ring lining 1° greater		39,2 x 2	A	0,20 ÷ 0,70
1° Compression lining 2° greater		39,4 x 1	A	0,08 ÷ 0,20
2° Compression lining 2° greater		39,4 x 1	A	0,05 ÷ 0,20
Scrapper ring lining 2° greater		39,4 x 2	A	0,20 ÷ 0,70
1° Scrapper ring lining 3° greater		39,6 x 1	A	0,08 ÷ 0,20
2° Scrapper ring lining 3° greates		39,6 x 1	A	0,05 ÷ 0,20

Name	Description	Dimensions	Initials	Quantity
Scrapper ring lining	3° greates	39,6 x 2	A	0,20 ÷ 0,70

**Crankcase - crankshaft - connecting rod**

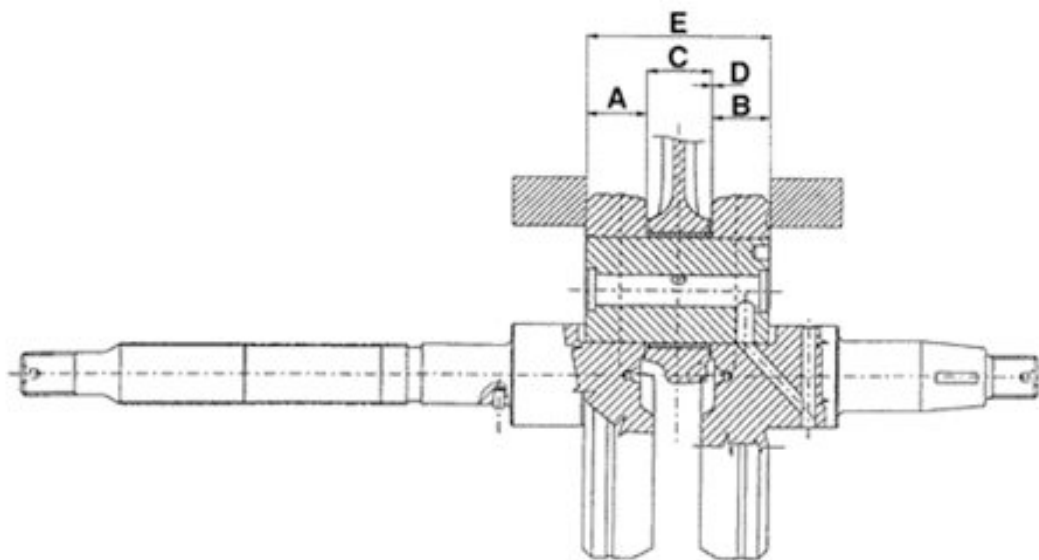

**END PLAY BETWEEN DRIVING SHAFT AND CONNECTING ROD**

Name	Description	Dimensions	Initials	Quantity
Half shaft trans- mission side		14 +0 -0,005	A	
Half shaft flywheel side		16 +0 -0,005	B	
Connecting rod		14,8 +0,05 -0	C	
Spacing tool		45,00 / assembly games D = 0,15 ÷ 0,30	E	

**Slot packing system**

N.B.

THE MEASUREMENT «A» TO BE TAKEN IS THE RETRACTION VALUE OF THE PISTON, INDICATED WHEN THE SURFACE FORMED BY THE TOP OF THE PISTON GOES BELOW THE SURFACE FORMED BY THE UPPER PART OF THE CYLINDER. THE MORE THE PISTON DESCENDS INTO THE CYLINDER, THE SMALLER THE HEAD SEAL TO APPLY WILL BE (TO RESTORE THE COMPRESSION RATIO) AND VICE VERSA.

Characteristic

**Shimming system to limit the compression ratio**

RC: 11,1 ÷ 12,9

**PISTON PROTRUSION CONTROL**

Name	Measure A	Thickness
Slot packing_1	0,05 ÷ 0,25	0,35
Slot packing_2	0,25 ÷ 0,40	0,25

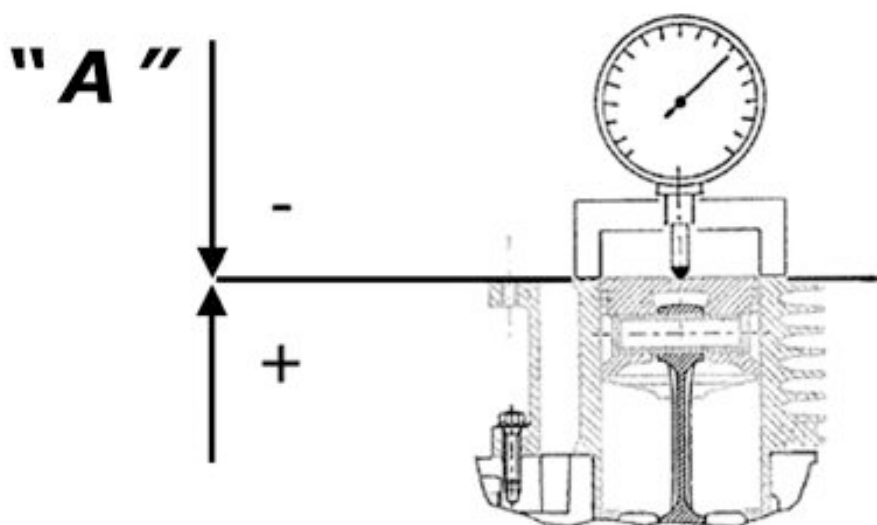

**N.B.**

THE MEASUREMENT «A» TO BE TAKEN IS THE RETRACTION VALUE OF THE PISTON, INDICATED WHEN THE SURFACE FORMED BY THE TOP OF THE PISTON GOES BELOW THE SURFACE FORMED BY THE UPPER PART OF THE CYLINDER. THE MORE THE PISTON DESCENDS INTO THE CYLINDER, THE SMALLER THE HEAD SEAL TO APPLY WILL BE (TO RESTORE THE COMPRESSION RATIO) AND VICE VERSA.

**Characteristic**

**Shimming system to limit the compression ratio**

RC: 11,1 ÷ 12,9

**PISTON PROTRUSION CONTROL**

Name	Measure A	Thickness
Slot packing_1	0,05 ÷ 0,25	0,35
Slot packing_2	0,25 ÷ 0,40	0,25

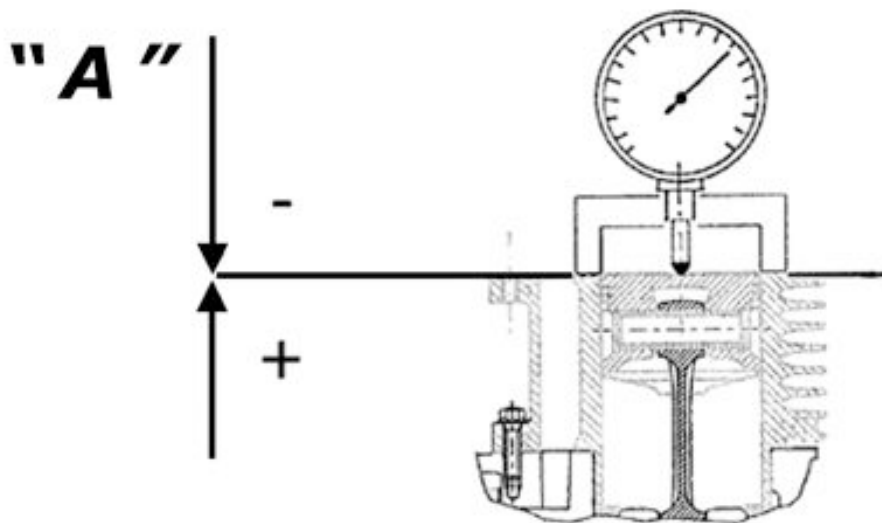

**Products**

**TABLE OF RECOMMENDED PRODUCTS**

<b>Product</b>	<b>Description</b>	<b>Specifications</b>
TUTELA MATRYX MOTO RIDER	Oil for rear hub	Oil synthetic multidegree SAE 75W/85 API GL4
SELENIA HI Scooter 4 Tech	Oil for flexible transmission lubrication (brake, acceleration control, km counter)	Oil for four stroke motors
SELENIA Air Filter Oil	Oil for air filter sponge	Mineral oil with specific additive for increasing the ISO VG 150
SELENIA HI Scooter 4 Tech	Engine oil	Synthetic oil SAE 5W/40 that passes the API SG specification.
JOTA 3 FS	Speedometer transmission	Lithium soap grease NLGI 33
TUTELA TOP 4	Brake fluid	Synthetic fluid SAE J1703, NHTSA 116 DOT 4, ISO 4925
MONTBLANC MOLYBDENUM GREASE	Grease for driven pulley shaft compensating ring and mobile driven pulley sliding seat	Molybdenum bisulphide grease
TUTELA ZETA 2	Grease for steering bearings and swing arm pin seats and driven pulley spring supporting surface (pulley side only)	Lithium soap and zinc oxide grease NLGI2
TUTELA TP1	Grease for brake control lever, gas	NLGI 1-2 calcium soap based white spray grease















## INDEX OF TOPICS

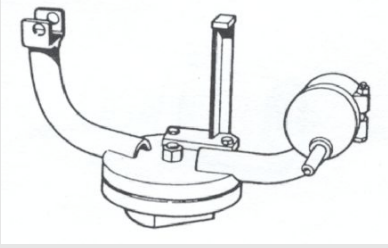

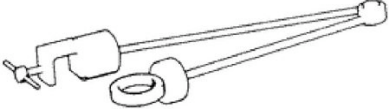

TOOLING

TOOL

**TOOLING**

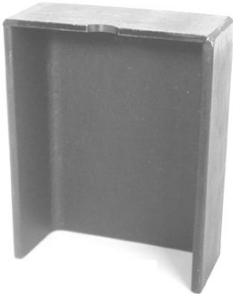
Stores code	Description	
001467y008	17 mm pliers (driven pulley bearings)	
001467y029	Drum (Driven pulley bearings)	
004499Y	Bearing extractor. Fitted with parts: 1 Drum, 2 Collar, 3 Screw, 6 Ring, 27 Half-rings, 34 Half-rings	
005095y	Engine support	
008119y009	Tube (shaft fitting tool)	
020004Y	Drift for removing thrust rings from steering head tube	

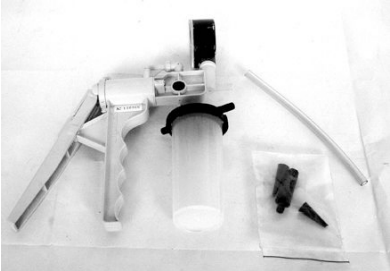
Stores code	Description	
020055Y	Steering tube ring nut spanner	
020074Y	Crankshaft aligning tool	
020150Y	Support for air heater "METABO HG 1500/2"	
020151Y	Air heater "METABO HG 1500/2"	
020162y	Flywheel extractor	
020171Y	Drift for driven pulley roller bearings	

Stores code	Description	
020265y	Bearing fitting stand	
020288y	Fork for fitting piston to cylinder	
020291y	Valves assembly/disassembly tool	
020306Y	Valve sealing ring drift	
020329Y	Pump MITYVAC	
020330Y	Timing light for two- and four-stroke engines	

**Stores code**

**Description**

020331Y

Digital multimeter



020332Y

Digital rpm counter



020333Y

Single battery charger

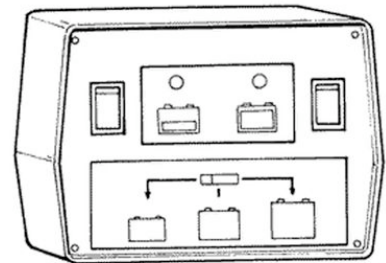

020334Y

Multiple battery charger



Stores code	Description
-------------	-------------

020335Y	Magnetic stand and comparator
---------	-------------------------------



020340Y	Punch for fitting oil guard mag- neto and transmission
---------	---



020358y	37 x40 adaptor
---------	----------------

020359Y	42 x 47 mm hub bearing fitting adaptor
---------	---

020360Y	52 x 55 mm adaptor
---------	--------------------

020362y	12 mm guide
---------	-------------







020363Y	20mm guide
---------	------------



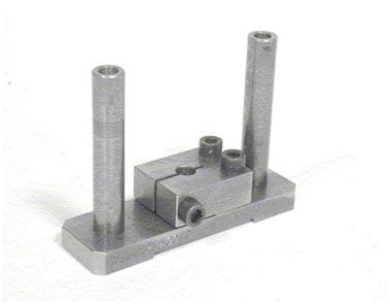

Stores code	Description	
020364Y	25 mm guide	
020376Y	Handle for punches	
020431Y	Valve oil seal extractor	
020432Y	Starting spring assembly tool	
020439Y	17 mm guide	
020444Y	Wrist-pin removal / fitting tool	

Stores code	Description	
020448y	Piston pin circlip fitting tool	
020449y	Piston protrusion support	
020450y	Camshaft fitting/removing tool	
020451Y	Drive-pulley retaining spanner	
020452y	Driven pulley shaft fitting/re- moving tube	
020456Y	Ø 24 mm adaptor	
020565Y	Compass flywheel stop spanner	

---

Stores code	Description
494929	Exhaust gas analyser

---



The image shows a rectangular, light-colored industrial device, the FLUX 4005 Infrared Multigas Analyser. The front panel features three digital displays at the top, each labeled with a gas type: CO, CO2, and HC. Below the displays are several control buttons and a small indicator light. The text 'FLUX 4005 INFRARED MULTIGAS ANALYSER' is printed in the center. At the bottom left, the 'PROTECH' logo is visible, and at the bottom right, the 'PIAGGIO' logo is present. A dark vertical slot on the right side of the device suggests a sample inlet or outlet.



## INDEX OF TOPICS

**MAINTENANCE**

**MAIN**

---



---

**Maintenance chart**
**EVERY 1000 KM OR 4 MONTHS**
**Action**

---

 Hub Oil - Replacement

---

 Valve clearance - Check

---

 Idling speed (\*) - Adjustment

---

 Acceleration command - Adjustment

---

 Steering - Adjust

---

 Brake levers - Grease

---

 Brake pads - Check condition + wear

---

 Brake fluid level - Check

---

 Nuts, bolts and fasteners - Check

---

 Electrical system and battery - Check

---

 Tyre pressure - Check

---

 Vehicle and brake test - Road test

(\*) See section «Adjusting the idle speed»

**AT 6000 KM OR 12 MONTHS, 18000, 30000, 42000, 54000 AND 66000 KM**
**Action**

---

 Engine oil - Replacement

---

 Hub oil level - Check

---

 Spark Plug / Electrodes distance - Check

---

 Oil filter (net) - cleaning

---

 Variator rollers - Check or Replacement

---

 Brake pads - Check condition + wear

---

 Brake fluid level - Check

---

 Electrical system and battery - Check

---

 Tires-inflation and wear - Check

---

 Vehicle and brake test - Road test

**EVERY 12000 OR 24 MONTHS AND AT 60000 KM**
**Action**

---

 Engine oil - Replacement

---

 Hub oil level - Check

---

 Spark plug/Electrode gap - Check/Change

---

 Air Filter - Cleaning

**Action**

Oil filter (net) - cleaning

Idling speed (\*) - Adjustment

Acceleration command - Adjustment

Variator rollers - Check or Replacement

Transmission Belt - Replacemen

Speedometer cable - Grease

Steering - Adjust

Brake levers - Grease

Brake pads - Check condition + wear

Brake fluid level - Check

Transmissions - Lubricate

Emergency blockings (°) - Check

Suspensions - Check

Electrical system and battery - Check

Headlight - Adjust

Tyres condition and wear - Check

Tyre pressure - Check

Vehicle and brake test - Road test

*(\*) Refer to rules (Check to CO) (°) Refer to predelivery operations*

**EVERY 24000 KM OR 48000 KM**

**Action**

Engine oil - Replacement

Hub oil level - Check

Spark plug/Electrode gap - Check/Change

Air Filter - Cleaning

Oil filter (net) - cleaning

Valve Play - Check

Idling speed (\*) - Adjustment

Acceleration command - Adjustment

Variator rollers - Check or Replacement

Transmission Belt - Replacemen

Cylinder cooling system - Check

Speedometer cable - Grease

Steering - Adjust

**Action**

Brake levers - Grease

Brake pads - Check condition + wear

Brake fluid level - Check

Transmissions - Lubricate

Emergency blockings (°) - Check

Suspensions - Check

Electrical system and battery - Check

Headlight - Adjust

Tyres condition and wear - Check

Tyre pressure - Check

Vehicle and brake test - Road test

*(\*)Refer to rules (Check to CO) (°) Refer to predelivery operations.***EVERY 36000****Action**

Engine oil - Replacement

Hub oil level - Check

Spark plug/Electrode gap - Check/Change

Air Filter - Cleaning

Oil filter (net) - cleaning

Idling speed (\*) - Adjustment

Acceleration command - Adjustment

Variator rollers - Check or Replacement

Transmission Belt - Replacemen

Speedometer cable - Grease

Steering - Adjust

Brake levers - Grease

Brake pads - Check condition + wear

Flexible brake lines - Change

Brake fluid level - Check

Transmissions - Lubricate

Emergency blockings (°) - Check

Suspensions - Check

Electrical system and battery - Check

Headlight - Adjust



---

**Action**

---

Tyres condition and wear - Check

Tyre pressure - Check

Vehicle and brake test - Road test

(\*)Refer to rules (Check to CO) (°) Refer to predelivery operations.

**EVERY 72000**

---

**Action**

---

Engine oil - Replacement

Hub oil level - Check

Spark plug/Electrode gap - Check/Change

Air Filter - Cleaning

Oil filter (net) - cleaning

Valve Play - Check

Idling speed (\*) - Adjustment

Acceleration command - Adjustment

Variator rollers - Check or Replacement

Transmission Belt - Replacemen

Cylinder cooling system - Check

Speedometer cable - Grease

Steering - Adjust

Brake levers - Grease

Brake pads - Check condition + wear

Flexible brake lines - Change

Brake fluid level - Check

Transmissions - Lubricate

Emergency blockings (°) - Check

Suspensions - Check

Electrical system and battery - Check

Headlight - Adjust

Tyres condition and wear - Check

Tyre pressure - Check

Vehicle and brake test - Road test

(\*)Refer to rules (Check to CO) (°) Refer to predelivery operations.

**EVERY 2 YEARS**

---

**Action**

---

Brake fluid - Change

**EVERY 3000 KM**

10'

---

**Action**

---

Engine Oil - Level Check/Top up

---

**Carburettor**



---

Disassemble all carburettor components, accurately wash them in solvent, then dry them with compressed air. To ensure thorough cleaning, pay special attention to the passages in the carburettor body.

- Carefully check the condition of all components.
- The **throttle** must slide freely in the chamber, if the play is excessive because of wear, replace the throttle.
- Replace the carburettor if the chamber shows signs of wear as to prejudice the valve's regular seal or free sliding (though it is new).
- When reassembling the carburettor, it is a good rule to replace the gaskets.

**WARNING**

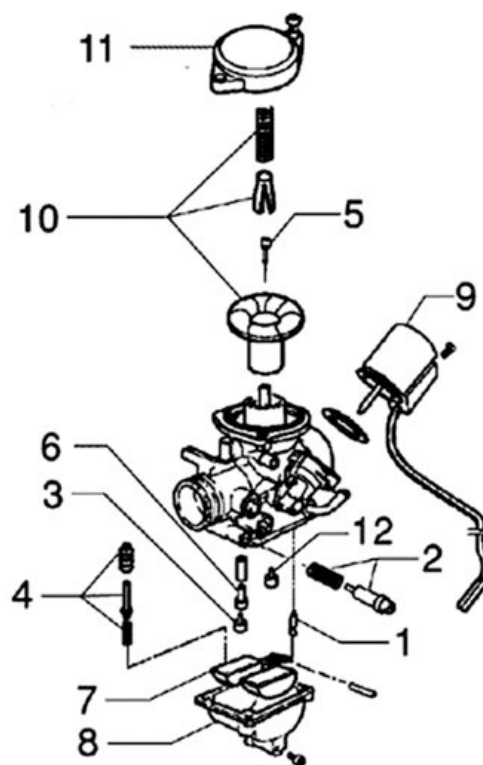
**PETROL IS HIGHLY EXPLOSIVE. ALWAYS FIT NEW SEALS AND GASKETS TO PREVENT LEAKAGE.**



1. Needle valve - 2. Idle speed adjusting screw - 3. Max jet - 4. Accelerating pump - 5. Conical needle - 6. Object carrier - 7. Float - 8. Float chamber - 9. Starting device - 10. Vacuum valve - 11. Cover - 12. Slow running jet.
- 

**Checking the spark advance**

The vehicle is provided with a variable spark advance electronic device. Two reference marks for the timing can be found on the flywheel cover as to find out with more precision the reference mark on the fan. To check, use a stroboscopic gun Tecnotest 130/P or similar type. Start the engine and let it run at 1900 revs/min, act on the phase shifter to align the reference mark on the flywheel fan in

---

between the two reference marks on the casing; at the same time, read the spark advance value on the stroboscopic gun display. The value should be 10°.

Repeat the above operation with engine running at 5000-6000 revs/min, spark advance should be 26°.

**CAUTION**

**IF THE FLASHING IS UNSTABLE AND THE RPM READING DOES NOT CORRESPOND TO THE ACTUAL CHANGE IN THE SPEED OF THE ENGINE (E.G. VALUES ARE REDUCED TO A HALF), INSERT A 10-15 KW RESISTIVE CABLE AND CONNECT IT IN SERIES TO THE HV CABLE. IF READING IRREGULARITIES PERSIST, CHECK THE IGNITION SYSTEM COMPONENTS.**

**N.B.**

**WHEN THE INDUCTION TWEEZERS READ THE SIGNAL PROPERLY, A READING OF MORE THAN 6,000 RPM CAN BE TAKEN**

**RPM LIMITER**

Specification	Desc./Quantity
1 spark out of 7	8200 Revs/min
1 spark out of 3	8300 Revs/min
Suppression of all sparks	8500 Revs/min

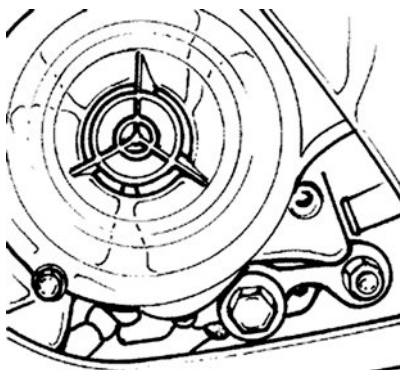

**CURVA DI VARIAZIONE ANTICIPO ACCENSIONE**

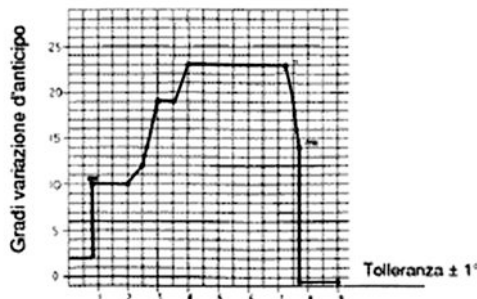

**Spark plug**

The central electrode of the above spark plug is treated with silicone oil that acts as an antioxidant agent. If the silicone oil is in excess, crystals tend to form and, by causing hot fire points to preignition

phenomena, tend to reduce the spark plug performance. This results in difficulties for vehicles to reach the maximum speed and anomalous noises.

If the above situation should occur, replace the spark plug before performing any other intervention.

Before installing the new spark plug, blow with air to remove the silicone oil in excess.

Direct the jet of compressed air into the round groove between the threaded metal part and the ceramic part of the inner electrode while turning the spark plug to allow removal of the oil in excess.

---

Detach the spark plug cap and then remove the spark plug.

- Carefully examine the spark plug, and replace it if the insulator is damaged or chipped.
- With the aid of a feeler gauge, measure the spark gap and, if necessary, adjust by bending outer electrode with care.
- Ensure the sealing washer is in good conditions.
- Refit the spark plug by engaging the thread manually and then tightening it to the prescribed torque using the box-spanner provided.

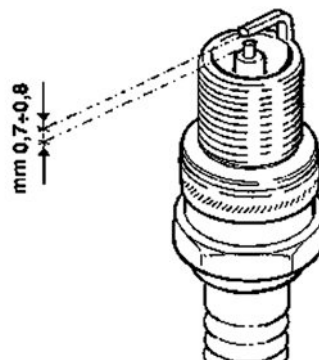

### Characteristic

#### Electrode gap

0,7 ÷ 0,8 mm

#### Spark plug

NGK CR 8EB

### Locking torques (N\*m)

Spark-plug 10 ÷ 15 N·m

---

## Hub oil

---

### Check

---

- Place the vehicle on the stand on level ground.
  - Unscrew oil dipstick «A», wipe it with a clean rag, reinsert it and **screw it in fully**.
  - Pull out the dipstick and check that the oil level is in the middle (two-notch dipstick) or reaches
-

the middle notch (three-notch dipstick).

- Reinsert the dipstick and screw it in fully.

### Recommended products

#### TUTELA ZC 90 Rear hub oil

SAE 80W/90 Oil that passes API GL3 specifications

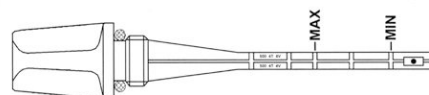
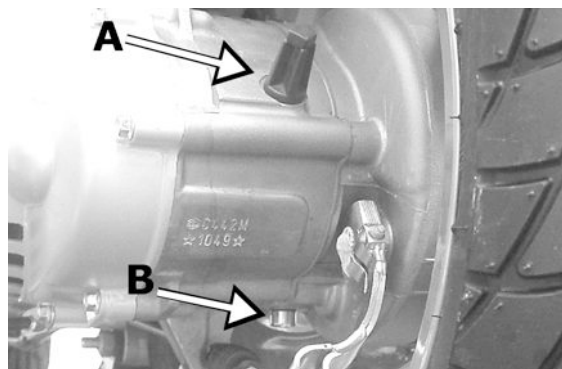

## Replacement

- Remove oil filler cap/dipstick «A».
- Unscrew the drain plug «B» shown in the figure and allow the oil to drain out.
- Retighten the drain plug and fill the hub with oil (about 100 cc).

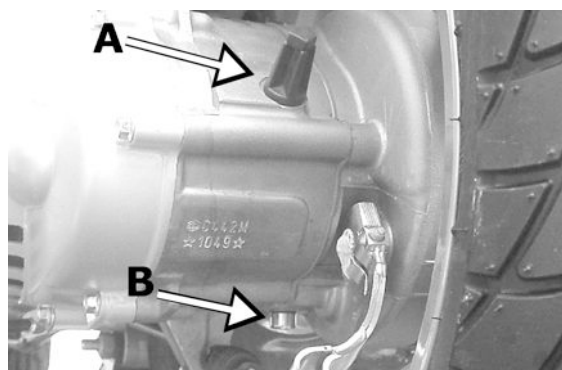

## Air filter

After removing the lower part of the left-hand side cover, unscrew the four fixing screws and the two knobs (which are exposed by overturning the saddle and removing the helmet compartment), remove the filter cover and then pull out the filter cartridge.

Cleaning:

- Wash the filter with soap and water.
- Dry with a clean cloth without wringing and with compressed air.
- Soak with a 50% fuel-oil mixture.
- Let the filter cartridge drip and then squeeze it

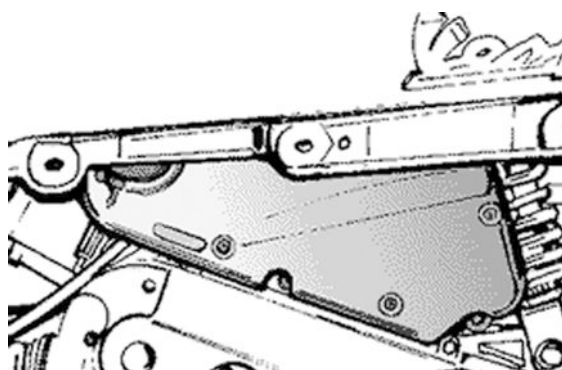

between the hands without wringing.

#### CAUTION

**NEVER RUN THE ENGINE WITHOUT THE AIR FILTER, THIS WOULD RESULT IN AN EXCESSIVE WEAR OF THE PISTON AND CYLINDER**

## Engine oil

### Replacement

- Loosen the oil filler plug.
- Unscrew the gauze strainer drain plug on the fly-wheel side and allow the oil to drain completely.
- Retighten the drain plug and pour in approximately 600-650 cc of oil.

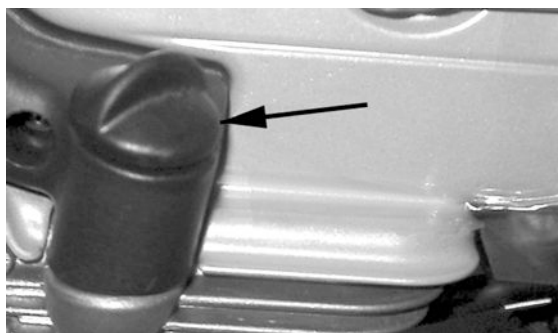

### Check

- Rest the vehicle (with the engine cold) on its centre stand on flat ground.
- Ensure the oil level is between the MAX and MIN marks on the dipstick.
  - The MAX mark implies a quantity of ~ 850 cc of oil in the engine.
  - If the oil level approaches the MIN mark, top up with fresh oil without ever exceeding the MAX mark.

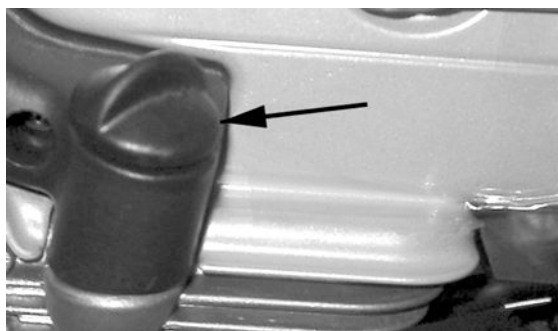

#### Recommended products

**SELENIA HI Scooter 4 Tech Oil for flexible transmission lubrication (brake, acceleration control, km counter)**

Oil for four stroke motors



## Engine oil filter

- Change the oil when the engine is warm.
- Place a container under the oil sump and remove the cap for draining the oil.
- After draining the oil clean the mesh filter with a specific solvent and then blow it down with compressed air.
- The latter is accessible by removing the cap «A» (see figure).
- After this operation refit the filter and tighten the oil cap to the sump using a new O-ring.
- Fill the engine oil through the hole located on the oil sump.
- Engine oil capacity: ~ 850 cc.
- Manually tighten cap.

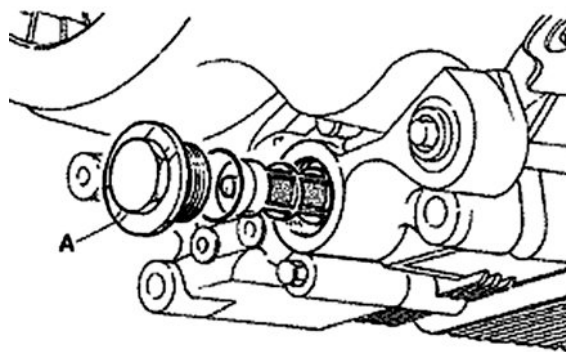
**N.B.**

**RUN THE ENGINE FOR A FEW MINUTES THEN RECHECK THE ENGINE OIL LEVEL WHEN THE ENGINE IS COLD, IT MUST ALWAYS REMAIN UNDER THE MAX LEVEL.**

**N.B.**

**IF FILLING FOR THE 1ST TIME OR FOR OVERHAUL ADD 850 C.C. OF ENGINE OIL, IN OTHER CASES 650 C.C. AND FILL UP IF NECESSARY.**

**Recommended products****SELENIA HI Scooter 4 Tech Engine oil**

Synthetic oil SAE 5W/40 of higher quality than API SJ specifications

**Locking torques (N\*m)**

**Engine oil prefilter cap 25 ÷ 28 N.m**

**Checking the ignition timing**

- Turn the flywheel magneto clockwise until the 2nd notch on its surface lines up with the Pick-Up notch, as shown in the figure.
- Ensure the reference on the camshaft drive

sprocket is lined up with the reference marking on the head, as shown in the second figure.

If the reference is opposite the index marked on the head, turn the crankshaft again, since the piston must be at the top dead centre of the combustion stroke.

**N.B.**

**- IF THE TIMING SYSTEM IS NOT TIMED, CARRY OUT THE ADJUSTING OPERATIONS AS DESCRIBED IN CHAPTER 6.**

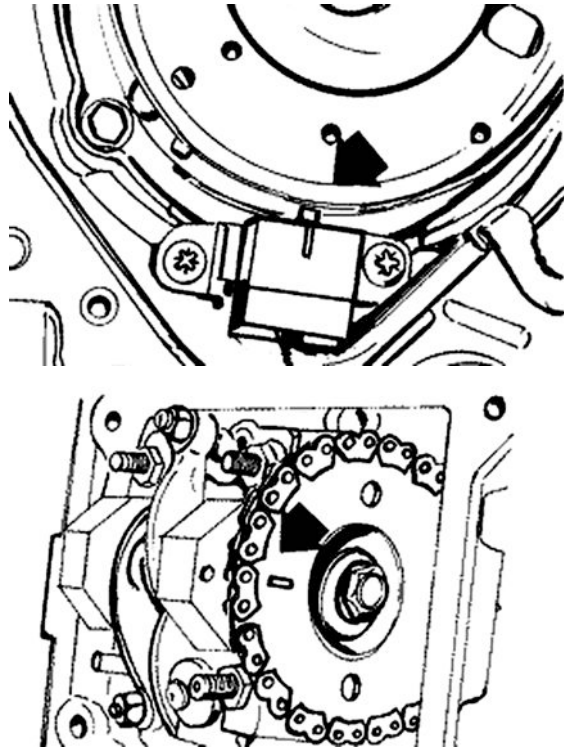

## Checking the valve clearance

- Remove the spark plug access door, by removing the 4 screws shown in the figure; hence remove the tappet cover.

- In order to check the valve clearance, align the valve timing references, as described earlier.

- With the aid of a feeler gauge, check the clearance between valve and adjusting screw is within the specified values.

- If the intake and exhaust valve clearance measurements differ from the values given below, adjust them through the adjusting screw, after loosening the counter nut, as shown in the figure.

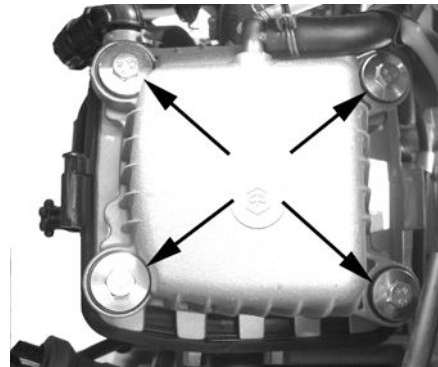

### Characteristic

#### Suction (cold engine)

0,10 mm

#### Exhaust (cold engine)

0,15 mm



## Headlight adjustment

Proceed as follows:

1. Place the vehicle, in riding order and with the tyres inflated to the prescribed pressure, on flat ground, 10 m away from a half-lit white screen. Ensure the vehicle axis is perpendicular to the screen;
2. Turn the headlight on and check the projection of the light beam is between  $7/10$  and  $9/10$  of the distance measured from the ground to the centre of the headlight;
3. Adjust the headlight as necessary, via screw «A».

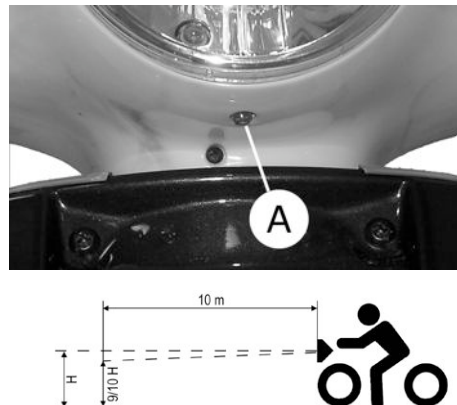

### WARNING

THE PROCEDURE DESCRIBED ABOVE COMPLIES WITH THE "EURONORM" CONCERNING THE MAX. AND MIN. HEIGHT OF THE LIGHT BEAM OF A ROAD VEHICLE. PLEASE CHECK WITH THE LOCAL AUTHORITIES FOR WHAT REQUIREMENTS MUST BE FULFILLED IN EVERY SINGLE COUNTRY WHERE THE VEHICLE IS TO BE USED.

## CO check

The check may be necessary in the event of irregularities in the engine performances, or when adjusting the engine idle speed.

- The test must be carried out only after having carefully cleaned all carburettor components with the air filter clean and the spark plug in good conditions.

- 1) Warm up the engine by riding the vehicle for about 5-10 minutes, as this is the time required for the choke device to disengage.
- 2) Shut down the engine only for the time re-

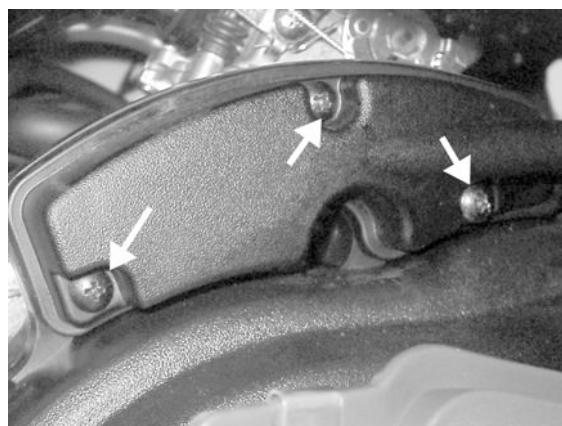

quired to carry out operations 3) and 4).

3) Remove the RH side fairing and the SAS box cover by loosening the 3 screws shown in the figure. Interpose a plastic sheet between the secondary air one-way valve and its housing on the cover. Ensure the valve gasket seals properly. Refit the SAS box cover.



4) Fit the special tool for the collection of exhaust gases as shown in the picture. Pay attention in ensuring the seal between the exhaust pipe and the collection tube. Insert the gas analyser and the exhaust tube.

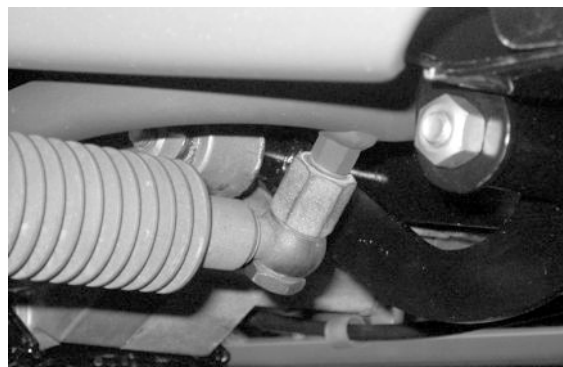

5) Insert the multimeter thermometer inside the sump, through the oil filler hole.

6) Start up the engine and, before adjusting the idle speed, ensure the oil temperature is between 70 and 80 °C.

7) Wait for a few minutes to let the temperature stabilise.

8) **Without ever activating the throttle** and through the idle screw, bring the engine speed to  $1,950 \pm 50$  rpm.

9) Adjust the flow screw so to obtain a "CO" reading of  $3.2 \% \pm 0.5 \%$ .

10) **Slowly** twist the throttle handgrip, bringing the engine up to a speed of 4,000 rpm and then release it; check the idle speed is the same as before, otherwise repeat the operations starting from point (3).

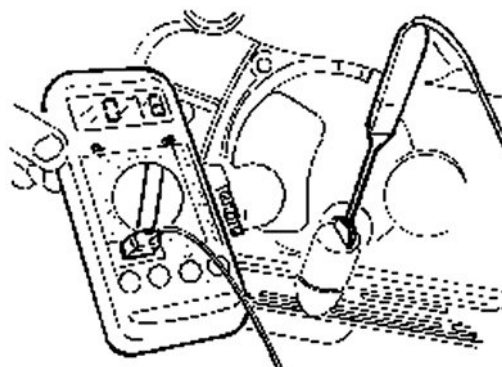

### Specific tooling

**020332Y Digital rpm counter**

**494929 Exhaust gas analyser**

**020331Y Digital multimeter**

---

## SAS filters inspection and cleaning

---

Use the two screws "A" on the right side panel and remove it. Use the three screws "B" to remove the cover of the secondary air box. Move the cover of the box away and remove the sponge filter "C". Wash the sponge with water and a neutral soap, and dry it with a clean rag and shorts blasts of compressed air. When cleaning the filter, make sure the reed valve "D" is in good condition then reinsert it in its seat on the box.

Before closing the SAS box cover, check the condition of the O-ring seal; replace it if it appears damaged or deformed.

**N.B.**

**THE REED VALVE CAN BE INSERTED INTO THE SAS BOX IN ONE WAY ONLY.**

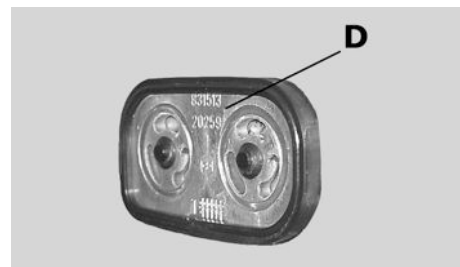
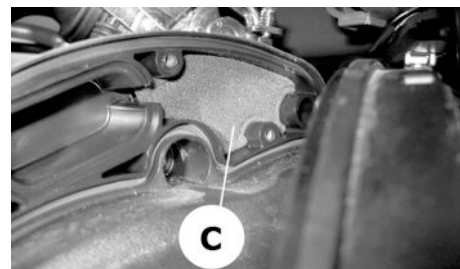
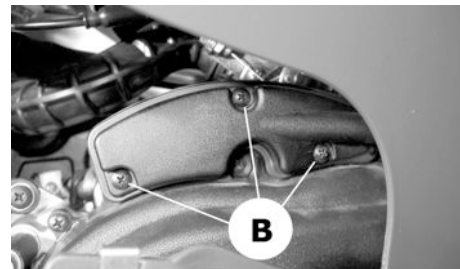



## INDEX OF TOPICS

TROUBLESHOOTING

TROUBL

**Engine**

**Poor performance**

**POOR PERFORMANCE**

<b>Possible Cause</b>	<b>Operation</b>
Air filter clogged or dirty	Disassemble, wash sponge with water and shampoo and immerse in a mixture of 50% petrol and Selenia Air Filter oil. Let it drip. Wring out without squeezing it and then refit
Carburettor jets clogged or dirty	Remove, wash in solvent and dry with compressed air
Vacuum fuel tap dirty or faulty	Check the tap's filter; if necessary drain the fuel and clean the tank. As a last resort, replace the fuel tap
Clutch slipping	Check and replace the clutch unit and/or the bell, if required
Inefficient automatic transmission	Check the pulley sliding and rollers, replace faulty components, lubricate the mobile driven pulley guide with grease Montblanc Molybdenum Grease
Low compression: wear of linings, cylinder and valve	Replace worn parts
Engine oil level exceeding the maximum	Check the causes and restore the correct level
Excessive scaling in the explosion chamber	Remove the scale from cylinder, piston, head and valves
Timing failure or timing system parts worn	Reset timing phase or replace any worn parts (refer to 4-stroke 50 cc engine manual)
Clogged silencer	Replace
Fuel filter on vacuum cock obstructed	Replace cock filter
Valve seat deformed	Replace the head unit
Defective float valve	Check the proper sliding of the float and the valve efficiency
Cylinder worn out / piston rings worn or broken	Replace the cylinder-piston assembly or the piston rings only

**Rear wheel spins at idle**

**REAR WHEEL**

<b>Possible Cause</b>	<b>Operation</b>
Idle speed set too high	Adjust slow running speed and C.O, if necessary.

Possible Cause	Operation
Faulty clutch	Check springs/weight of friction and clutch housing pan
Air filter box not sealed	Refit filter box. Replace if it is damaged
Cleaner-carburettor union damaged	Replace

## Starting difficulties

### STARTING PROBLEMS

Possible Cause	Operation
Spark plug faulty or electrodes gap incorrect	Check spark plug and electrodes gap. Replace if necessary
Battery is down	Check the battery charge condition. If the battery shows signs of sulfation, replace it. Before installing the new battery, charge it for eight hours with a current corresponding to 1/10 of the capacity of the battery
Engine flooding	Open the throttle wide and try to start the engine. If the engine does not start, remove the spark plug, run the engine with throttle open making sure the cap is connected to the spark plug and the spark plug is earthed, far from the hole. Fit a dry spark plug and start the engine.
Vacuum fuel tap faulty	Check fuel outflows correctly from the outlet hose when simulating a vacuum in the vacuum hose.
Automatic choke device (on carburettor) faulty	Check the wiring and ensure the pin slides correctly; replace if necessary.
Spark advance faulty	Check flywheel keying on driving shaft, replace gearcase if necessary
Incorrect valve seal or wrong valve adjustment	Inspect the head and/or set the correct clearance
Starting rpm too low. Starter motor faulty.	Check starting motor.
Altered fuel characteristics	Drain altered fuel and refuel
Carburettor jets clogged or dirty	Remove, wash in solvent and dry with compressed air

## Engine tends to cut-off at full throttle

### ENGINE TENDS TO CUT OUT AT FULL THROTTLE

Possible Cause	Operation
Main jet obstructed	Remove the carburettor, clean with solvent and then dry with compressed air.
Water or condensate in float chamber	Remove float chamber, wash in solvent and dry

Possible Cause	Operation
	with compressed air. Drain float chamber through the drain screw.
Spark advance incorrect	Check the spark advance using a stroboscopic lamp and make sure that the flywheel is properly keyed.
Air filter clogged or dirty	Remove the sponge, wash with water and shampoo, then impregnate it in a 50% mixture of fuel and specific oil (Selenia Air Filter Oil), then press it without squeezing, let it drip and replace it
Incorrect float level	Restore correct level according to directions (the float must be parallel with the top cover bearing surface, that is the throttle valve diaphragm cover)
Throttle feeding pipes	Restore the proper fuel passage
Fuel vent pipe clogged	Restore the proper tank aeration
Level in float bowl too low	Top up according to directions (the float must be parallel with the top cover bearing surface, that is the throttle valve diaphragm cover)

### Engine tends to cut-off at idle

#### ENGINE TENDS TO STOP WHEN IDLING

Possible Cause	Operation
Calibrated air holes on carburettor obstructed	Remove, wash in solvent and dry with compressed air
Defective float valve	Check the proper sliding of the float and the valve efficiency
Level in float bowl too high	Restore correct level according to directions (the float must be parallel with the top cover bearing surface, that is the throttle valve diaphragm cover)
Automatic choke stays activated	Check that the piston slides freely and that fuel is supplied to the automatic choke. Renew if necessary
Air filter clogged or dirty	Remove the sponge, wash with water and shampoo, then impregnate it in a 50% mixture of fuel and specific oil (Selenia Air Filter Oil), then press it without squeezing, let it drip and replace it
Slow running incorrectly tuned up	Tune up slow running and check C.O. level
Spark plug faulty	Replace spark plug with an equivalent part having the prescribed heat grade. Check electrodes gap
Compression end pressure too low	Check the seals of the thermal unit and replace



Possible Cause	Operation
	worn components
Wrong timing	Adjust the timing and check the timing components

## High fuel consumption

### EXCESSIVE FUEL CONSUMPTION

Possible Cause	Operation
Air filter clogged or dirty	Remove the sponge, wash with water and shampoo, then impregnate it in a 50% mixture of fuel and specific oil (Selenia Air Filter Oil), then press it without squeezing, let it drip and replace it
Choke stays open	Check sliding and feed of choke
Slackened nozzles	Check the maximum and minimum nozzle locking into their seat
Float level incorrect	Check and restore the fuel level in the float chamber

## Transmission and brakes

### Clutch grabbing or performing inadequately

#### CLUTCH IRREGULAR OPERATION OR TEARING

Possible Cause	Operation
Faulty clutch	Check that the masses are free from grease. Check that the contact surface of the clutch masses with the bell is mainly in the centre and with the same features on the three masses. Check that the clutch bell exhibits no abnormal wear or scratches.

### Insufficient braking

#### INEFFICIENT BRAKING

Possible Cause	Operation
Bake pads or shoes worn	Replace the pads or shoes and check the status of the brake disc or drum
Air bubbles in the braking hydraulic system	Carefully bleed the hydraulic system (spring action of the brake lever should not be felt)
Brake disc or drum distorted	Using a comparator, check the flatness of the disc with the wheel properly in place. Check the con-

Possible Cause	Operation
	centricity of the rear drum and the tightening of the brake disc screws
Fluid leakage in hydraulic braking system	Control linkage, piston or brake pump gaskets failure. Renew
Excessive play of rear brake control cable	Adjust the play by operating the specially designed adjuster on the shoe control lever
Worn fluid	Change the front brake fluid and restore correct level in the pump
Return spring broken	Renew spring.
Shoe control pin not lubricated	Lubricate with Z2 grease

### Brakes overheating

#### BRAKES OVERHEATING

Possible Cause	Operation
Pistons defective sliding	Check caliper, renew any damaged part
Brake disc or drum distorted	Using a comparator, check the flatness of the disc with the wheel properly in place. Check the concentricity of the rear drum and the tightening of the brake disc screws

### Electrical system

#### Battery

#### BATTERY

Possible Cause	Operation
The battery requires regular maintenance.	If the vehicle is to remain idle for a month or more, the battery must be charged from time to time. Over a period of 5 - 6 months disuse, the battery will discharge completely. When installing the battery, make sure you connect black ground lead to the negative terminal and the red lead to the positive terminal

### Turn signal lights malfunction

#### ELECTRICAL EQUIPMENT FAILURE

Possible Cause	Operation
Direction indicator flashers failure	Check the regulator and wires according to directions

## Steering and suspensions

### Heavy steering

#### HARDENING STEERING

Possible Cause	Operation
Excessive steering wheel clearance	Check the tightening of the top and bottom ring nut. If the anomaly continues during the steering wheel rotation even after the adjustment, check the bearing ball rolling seats. If they are recessed or if the balls are squashed, replace.

### Excessive steering play

#### STEERING PLAY EXCESSIVE

Possible Cause	Operation
Steering play excessive	Check the tightening of the upper and lower rings. If steering rotation is still uneven, check the bearing ball rolling races. Replace if the races appear to be embedded or if the balls are flattened

### Noisy suspension

#### SUSPENSION NOISY

Possible Cause	Operation
Suspension noisy	<p>If the front suspension is noisy, check the operation of the front shock absorber and the condition of the ball bearings.</p> <p>Check the tightening torques of the wheel hub, the brake caliper, the brake disc and the shock absorber on the hub and steering tube connections.</p> <p>Check the operation of the swinging arm connecting the engine to the frame and the function of the rear shock absorber</p>

### Suspension oil leakage

#### OIL LEAKING FROM SUSPENSION

Possible Cause	Operation
Oil leaking from suspension	Replace the shock absorber



# INDEX OF TOPICS

ELECTRICAL SYSTEM

ELE SYS

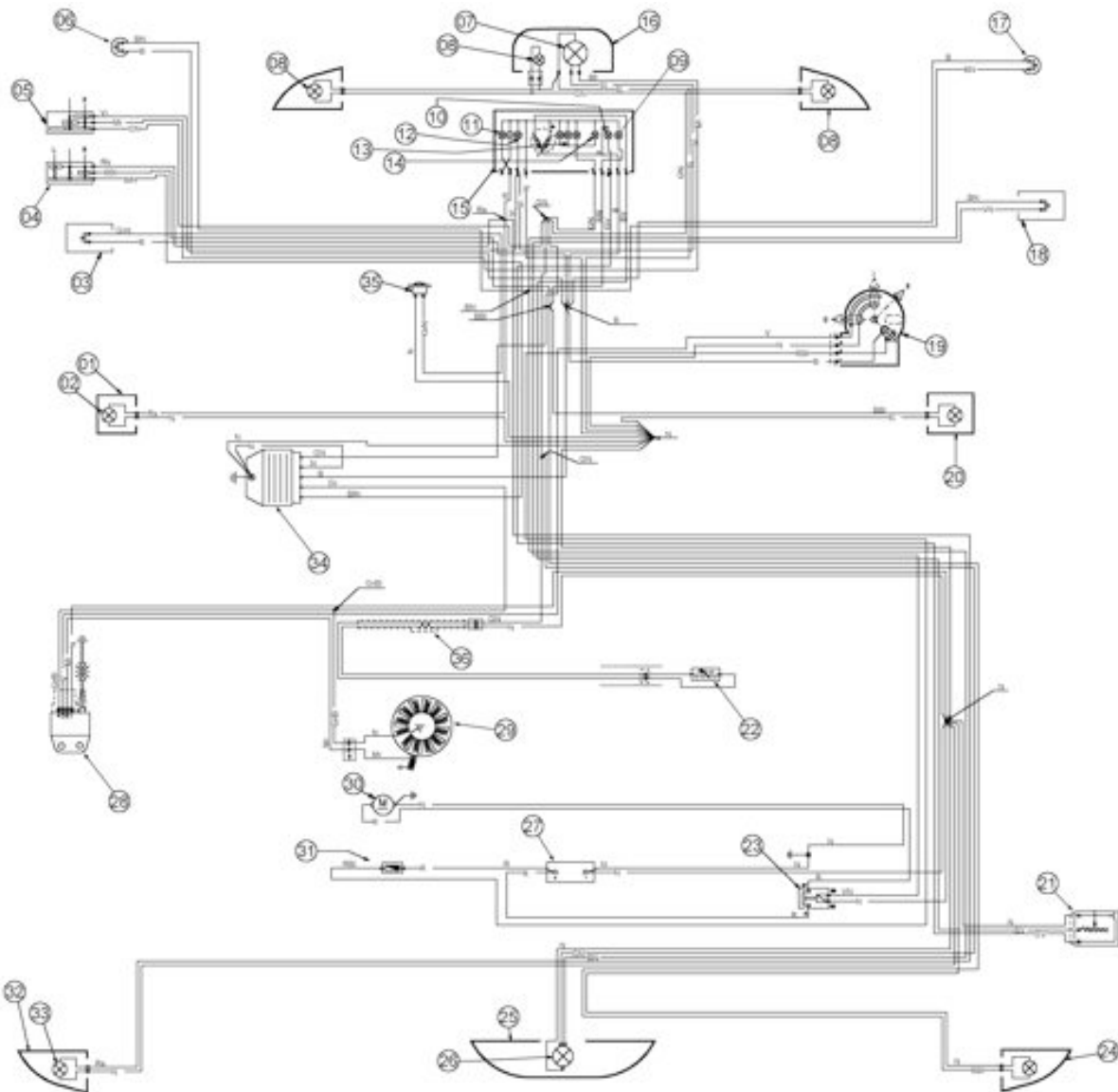

**ELECTRICAL COMPONENTS**

	<b>Specification</b>	<b>Desc./Quantity</b>
1	Front L.H. turn signal light	
2	Front direction indicator lights	12V-10W x 2
3	Horn button	
4	Indicators switch	
5	Light switch	
6	Rear stop switch	
7	Headlight bulb	12V-35/35W
8	Front parking light bulb	<b>Type: BAYONET</b> <b>Voltage supply/Power: 12V 5W</b> <b>Quantity: 1</b>
9	Right turn indicator warning light	12V-2W

	Specification	Desc./Quantity
10	Reserve fuel light	12V-1,2W
11	left turn indicator warning light	12V-2W
12	High beam warning light bulb	12V-1,2W
13	Dashboard light bulbs	<b>Type:</b> Bayonet <b>Power:</b> 12V 1.2W <b>Quantity:</b> 3
14	Headlamp warning light	12V 1,2W
15	Odometer with warning lights and level gauges	
16	Front headlight	
17	Front brake stop light switch	
18	Starter button	
19	Ignition key-switch	
20	Front R.H. turn signal light	
21	Fuel level sender	
22	Automatic starter	
23	Starter relay	
24	Rear R.H. turn signal light	
25	Taillight assembly	
26	Parking and stop light bulbs	<b>Type:</b> SPHERICAL <b>Voltage supply/Power:</b> 12V 21/5W <b>Quantity:</b> 1
27	Battery	12V - 9Ah
28	Control device ignition	
29	Flywheel magneto	
30	Starter motor	
31	Fuse carrier	(N° 1 fuse to 10 A)
32	Rear L.H. turn signal light	
33	Rear direction indicator lights	N° 2, 12V-10W, spherical
34	Voltage regulator	
35	Claxon in c.c.	
36	Resistance	10 Ohm - 10W

**Electrical cables color:**

**B** = White, **Bl** = Blu, **G** = Yellow, **Mr** = Brown, **N** = Black, **Gr** = Gray,

**Rs** = Pink, **R** = Red, **Vi** = Purple, **V** = Green

**Conceptual diagrams**

**Ignition**

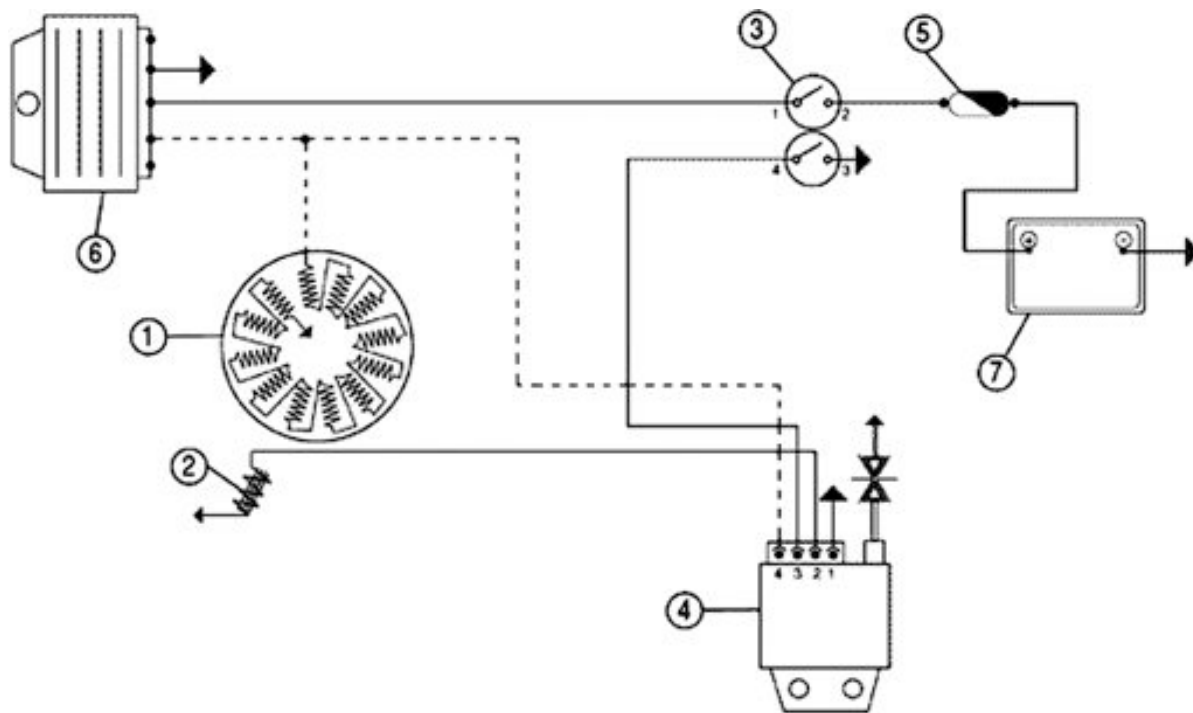

**IGNITION**

	Specification	Desc./Quantity
1	Magneto flywheel	
2	Pick - up	
3	Key switch contacts	
4	Electronic ignition device	
5	Fuse	10 A
6	Voltage regulator	
7	Battery	12V-9Ah

**Headlights and automatic starter section**



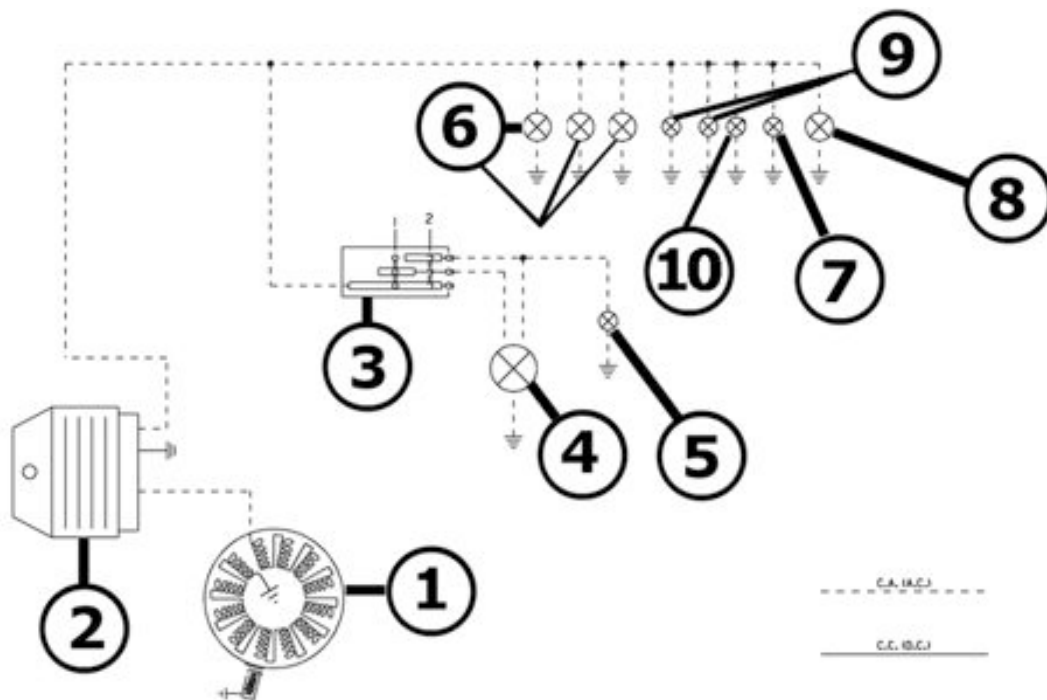

**HEADLIGHTS**

	Specification	Desc./Quantity
1	Magneto flywheel	
2	Voltage regulator	
3	Light switch	
4	Headlight bulb	12V-35/35W
5	High beam warning light bulb	12V-1,2W
6	Rear light bulb	12V - 5W
7	Headlight warning light	12V - 1.2W
8	Front position light filament	12V - 5W
9	License plate light bulb	<b>Type:</b> BAYONET <b>Voltage supply/Power:</b> 12V 1,2W <b>Quantity:</b> 2
10	Dashboard light bulbs	12V-2W

**Battery recharge and starting**

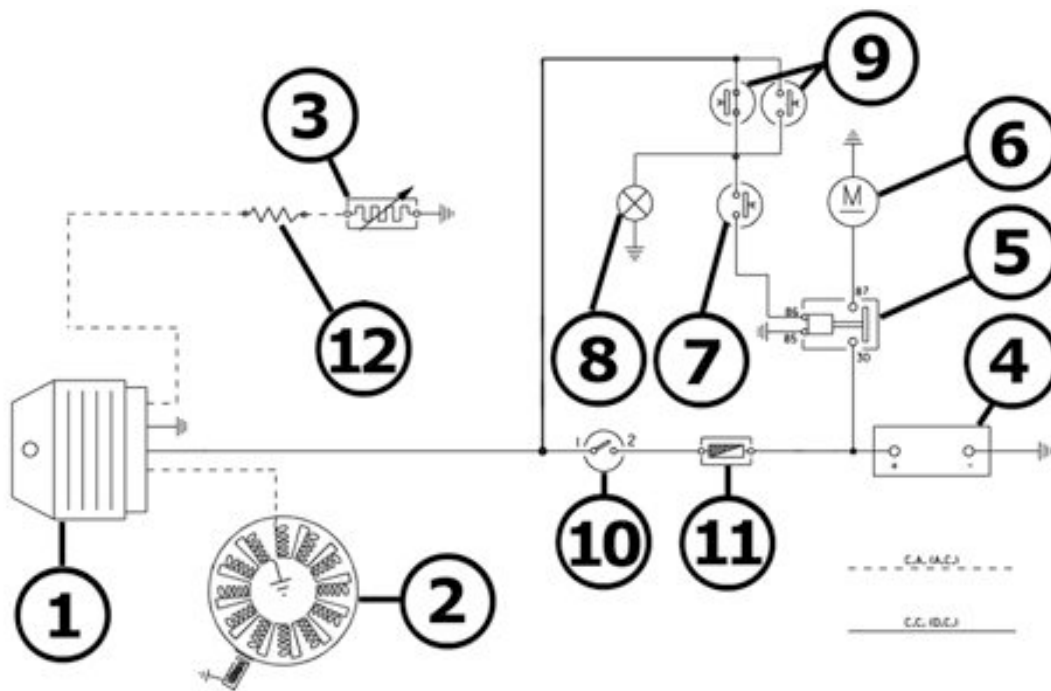

**BATTERY RECHARGE AND START-UP SECTION**

	Specification	Desc./Quantity
1	Voltage regulator	
2	Magneto flywheel	
3	Automatic starter	
4	Battery	12V-9Ah
5	Remote starter switch	
6	Starter motor	
7	Start up button	
8	Brake light filament	12V-21W
9	Front and rear brake light button	
10	Key switch	
11	Main fuse	10A
12	Resistance	6,8 Ohm - 10W

**Level indicators and enable signals section**

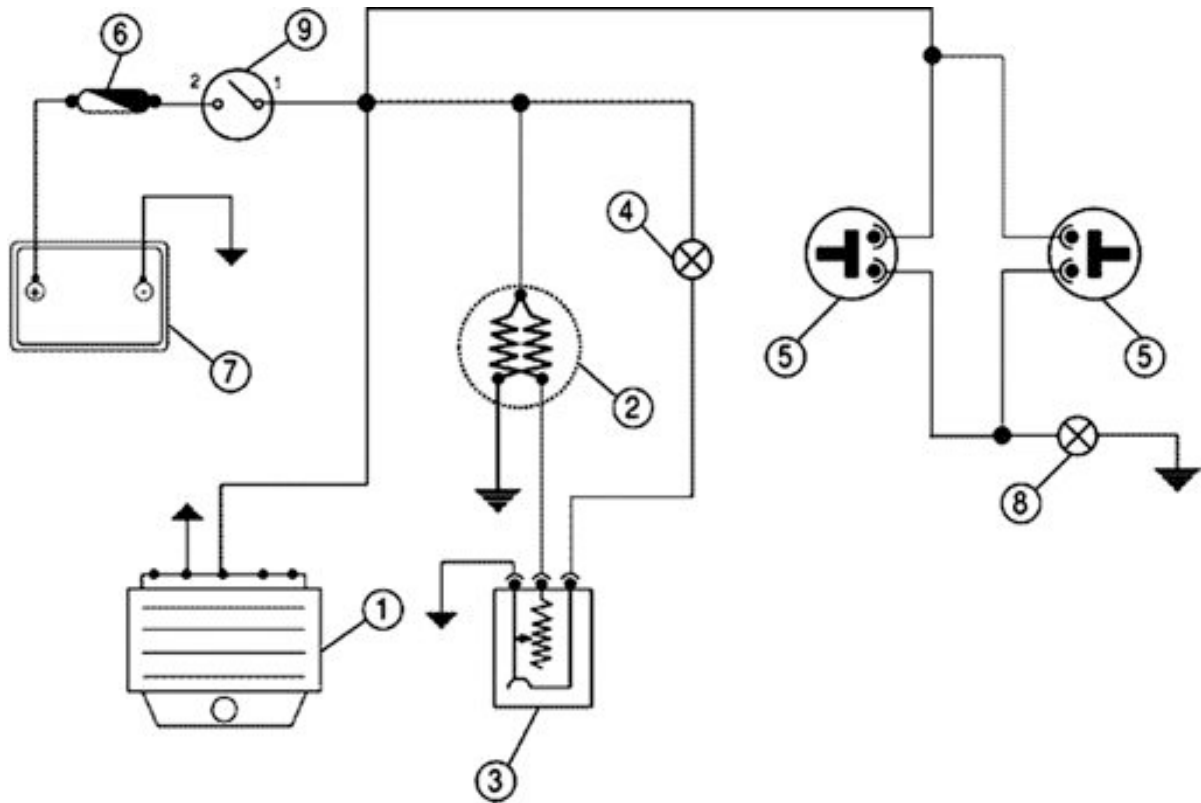

**START PERMISSIVE BUTTONS AND LEVEL INDICATORS**

	Specification	Desc./Quantity
1	Voltage regulator	
2	Fuel Level indicator	
3	Fuel level sender	
4	Reserve fuel light	12V-1,2W
5	Front and rear brake light button	
6	Fuse	10 A
7	Battery	12V-9Ah
8	Brake light filament	12V-21W
9	Key switch contacts	

**Turn signal lights**

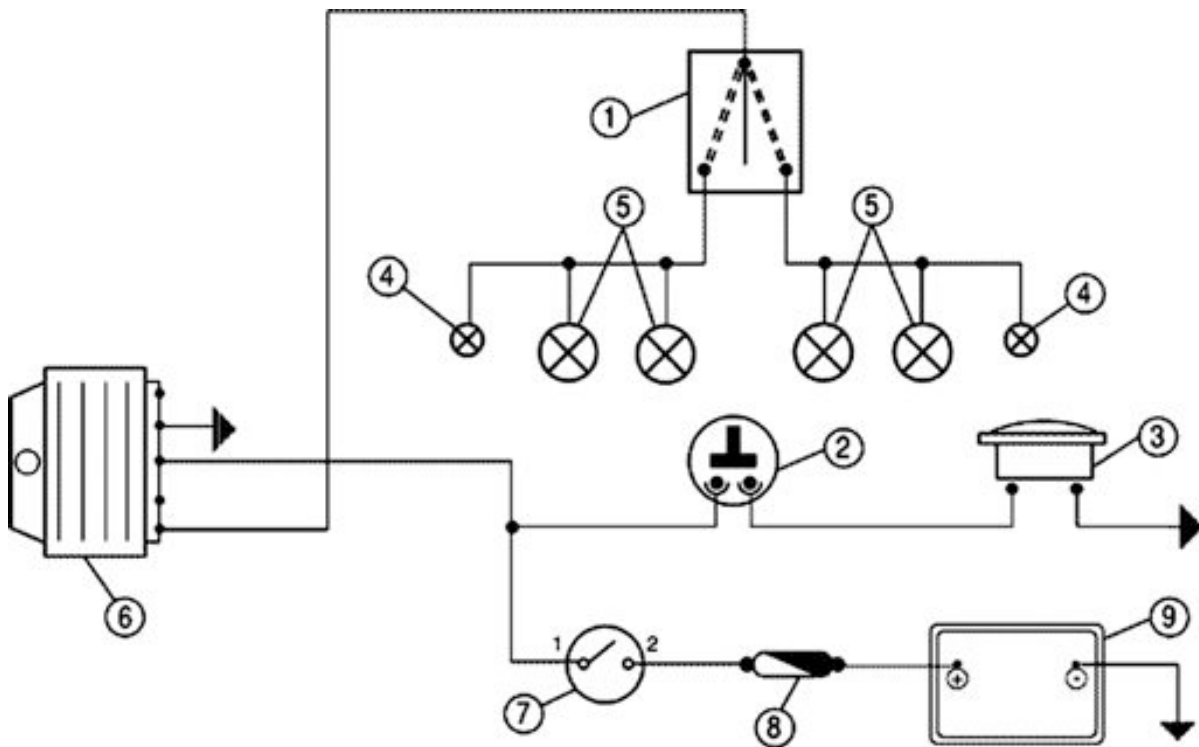

**TURN INDICATORS AND HORN**

	Specification	Desc./Quantity
1	Indicators switch	
2	Horn button	
3	Horn	
4	Two (2) turn signal warning light bulbs	12V - 2W
5	4 Turn indicator bulbs	12V-10W
6	Voltage regulator	
7	Key switch contacts	
8	Fuse	10 A
9	Battery	12V-9Ah

**Instruments and warning lights control board**

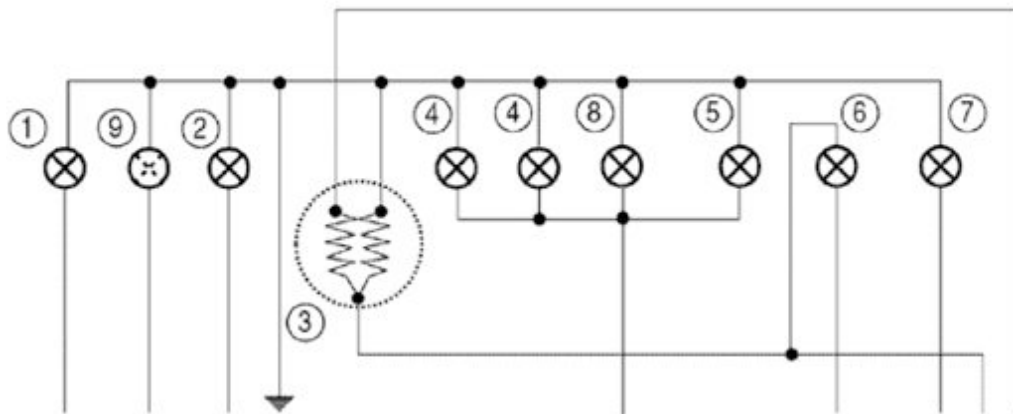

**WARNING LIGHTS AND GAUGES PANEL**

	Specification	Desc./Quantity
1	left turn indicator warning light	12V-2W
2	High beam warning light bulb	12V-1,2W
3	Fuel Level indicator	
4	Instrument panel lighting bulb	12V-1,2W
5	Headlamp warning light	12V 1,2W
6	Reserve fuel light	12V-1,2W
7	Right turn indicator warning light	12V-2W
8	Dashboard light bulbs	12V-2W
9	Available warning light	

**Checks and inspections**

In case of faulty or failed operation of the ignition system and if the cause cannot be found by a simple visual inspection, replace the C.D.I. module with another of the same type and certainly working.

Remember that the disconnections needed to replace the C.D.I. module are to be carried out while the engine is switched off.

If the replacement restores the ignition system to proper operation, the fault is to be found in the C.D.I. module, which will have to be replaced.

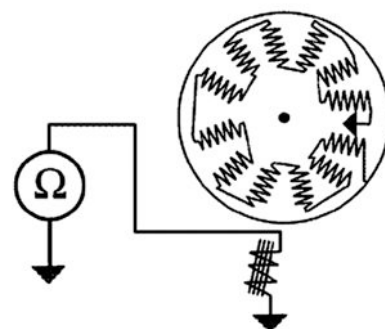

If faulty or failed operation persists, conduct the

following checks on the generator and on the stator components:

After a visual inspection of the electrical connections, it is possible to perform measurements on the stator winding and pick-up (see table), using the specific multimeter.

If, during the checks on the charge coil and the pick-up, anomalies are found, replace the stator and other faulty parts.

Disconnect the connector on the flywheel housing and measure the resistance between each of the two contacts and the earth.

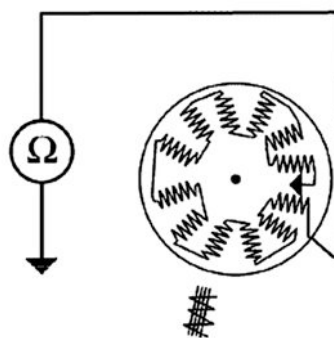

### Specific tooling

020331Y Digital multimeter

#### PICK-UP TEST

	Specification	Desc./Quantity
1	1) Brown and ground cable	~ 170 Ω

#### STATOR WINDING CHECK

	Specification	Desc./Quantity
1	1) Black and ground cable	~ 1 Ω

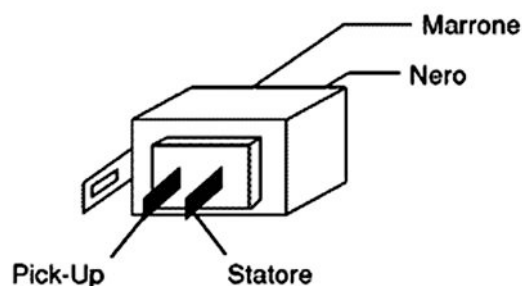

### Ignition circuit

All checks on the electrical equipment involving the disconnection of cables (checks on ignition circuit connections and devices) are to be carried out while the engine is switched off. Should the engine be running, the C.D.I. module could suffer

irreparable damage.

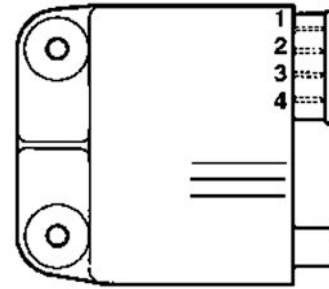

## Stator check

- Using a tester check the resistance between the brown-ground and black-ground terminal.

**N.B.**

**THE VALUES ARE STATED FOR AMBIENT TEMPERATURE. CHECKING THE STATOR AT OPERATING TEMPERATURE WILL BRING THE VALUES ABOVE THE STATED ONES.**

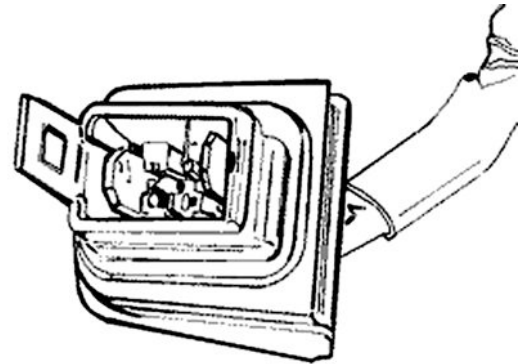

### Electric characteristic

**Stator : brown - ground**

~ 170  $\Omega$  (Pick-Up)

**Stator : black-ground**

~ 1  $\Omega$  (Stator)

## Voltage regulator check

If the voltage regulator is faulty, the following problems may occur depending on the type of regulator malfunction:

- 1) Bulbs burnt out (regulator in short circuit).
- 2) The lighting and electrical starter system do not work (regulator interrupted).
- 3) Battery fails to charge
- 4) Turn indicators failure

The regulator is provided with earth supplied from the electrical equipment, therefore the regulator body does not supply earth to the internal circuits. Check the insulation between each terminal of the regulator and its body, using the specific tester.

2) LIGHTS AND CHOKE DEVICE NOT OPERA-

## TIONAL

Remove the plastic door on the leg-shield to reach the voltage regulator, start the engine and let it run at idle.

Place the positive terminal from the tester on terminal no. 1 (yellow-black wire) and the negative terminal on terminal no. 2 (black wire); check for voltage.

If voltage is present, check the wiring connecting the headlight switch to the voltage regulator, and the operation of the light switch.

If no voltage is found, put the negative terminal to earth; if this provides voltage readings, check the earth wire on the regulator; otherwise, replace the regulator as certainly faulty.

As a last test it is possible to check the output voltage from the stator:

-Detach the regulator connector and interpose the tester between the Gray-Blue wire (4) and earth (see figure).

-The voltage output at 2,000 rpm must be approx. 25 - 35V. If this test gives no voltage readings too, replace the regulator as certainly faulty.

**N.B.**

**FOR THE ABOVE MEASUREMENTS, USE AN ANALOGUE MULTIMETER FOR AC CURRENTS AND KEEP THE ENGINE IDLING SO AS TO OBTAIN AN ALTERNATING VOLTAGE WITH A FREQUENCY AS CLOSE AS POSSIBLE TO 50 HZ AND MEASURE THE EFFECTIVE VOLTAGE OUTPUT FROM THE REGULATOR (APPROX. 12 V).**

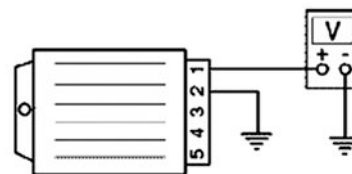
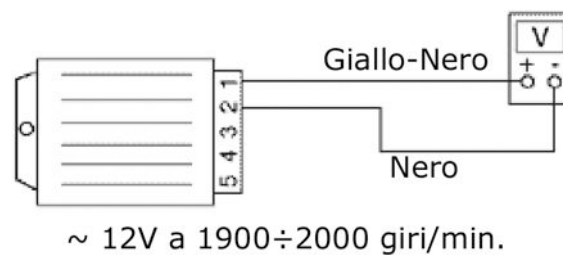
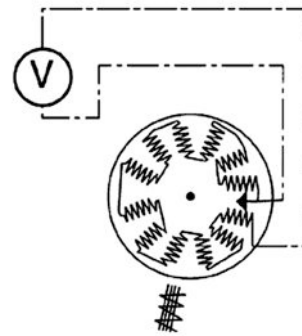

~ 12V a 1900÷2000 giri/min.

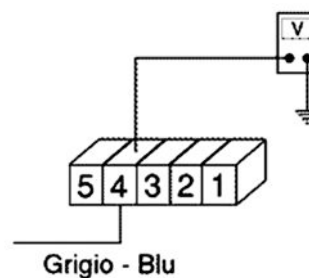

~ 25÷35V a 1900÷2000 giri/min.

## Recharge system voltage check

### 3) BATTERY DOES NOT RECHARGE

The fault in the DC section of the voltage regulator or may cause, depending on the type of failure,



the following faults:

- a) **Bursting of protection fuse due to excessively high voltage (regulator short-circuited) and resulting in the battery not recharging.**
- b) **Battery not recharging (regulator circuit interrupted).**

#### Interventions

- a) Bursting of protection fuse (regulator short-circuited).

Check the wiring running from the fuse to the ignition key-switch is not damaged, as this may create a short-circuit with earth (thus excluding possible regulator failures); if the protection fuse bursts only after the ignition key-switch is turned to "ON", and with the regulator connector detached, it is then necessary to check the wirings and systems downstream the key-switch are not short-circuited with earth.

Proceed by measuring the resistance between contacts 3 (White) and 2 (Black) from the voltage regulator (with the connector detached).

If the reading differs excessively from the figures shown, replace the regulator as short-circuited.

- b) Battery not recharging (regulator circuit interrupted).

To check for the presence of faults on the recharging section of the voltage regulator, it is necessary to initially operate on the battery, using two testers (one for voltages and one for currents), as shown in the second figure, and follow the operations given below:

Start the engine (connecting, temporarily, the red wire to the positive terminal of the battery, so to avoid damaging the instrument measuring the current).

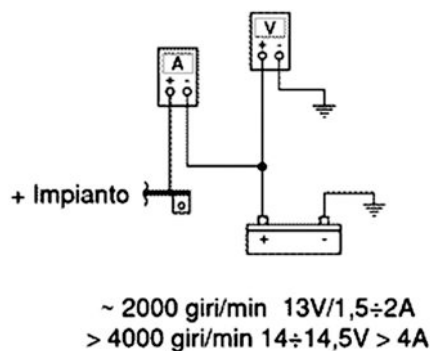
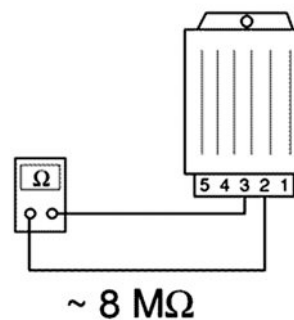

Check the voltage at idle is at least 13V (charged battery) and the recharge current is 1.5 - 2A with the lighting system and the choke device excluded, as described in the chapter "CHECKING THE VOLTAGE REGULATOR".

As the engine speed increases, so do the recharge current and voltage, and at speeds above 4,000 rpm, a recharging current of approx. 4.5A must be observed; reactivating the lighting system and choke device, and operating the stop light and horn, current values of  $\geq 5A$  may be found, with voltage readings of 14 - 14.5V (regulator threshold voltage).

**If the readings do not match the above figures, replace the regulator; otherwise check wiring and connections.**

### Electric characteristic

#### Resistance of voltage regulator

~ 8 M $\Omega$

## Turn signals system check

### 4) TURN INDICATORS FAIL TO OPERATE

In case of turn indicators fault, proceed as follows:

- Remove the regulator connector and insert the multimeter prods between white wire (3) and black wire (2).
- Turn the key switch to ON and check that the battery is powered. If no voltage is measured, repeat the test between the earth and white cable. If the check is still unsuccessful, check the cables and the contacts on the key switch and battery. If the battery voltage is measured, check the regulator earth cables (black cable)

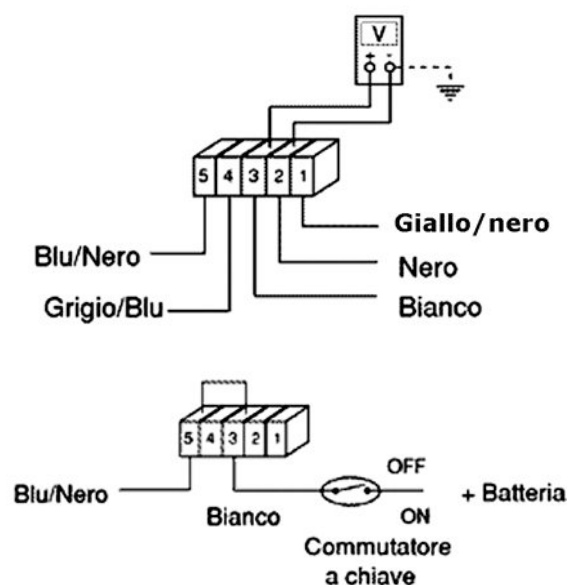

- If the above checks are successful, jump contacts 5 (blue/black) and 3 (white) on the connector, turn the key switch to ON and turn the flashlights switch to the left and to the right to check if lights goes on (these are directly fed by the battery).

If the flashlights do not go on, check the cables and the switch operation; otherwise, replace the regulator since it is faulty.

### **Specific tooling**

**020331Y Digital multimeter**

---

## **Sealed battery**

RECHARGING THE BATTERY FOLLOWING OPEN-CIRCUIT STORAGE

### **1) Checking the voltage**

Before installing the battery on the vehicle, measure the open-circuit voltage with an ordinary multimeter.

- If the voltage exceeds 12.60 V, the battery can be installed without recharging.
- If the voltage is less than 12.60 V, recharge the battery as described at item 2).

### **2) Constant-voltage charging method**

- Constant voltage: 14.40-14.70 V
- Initial charging current: 0.3-0.5 x rating
- Charging time:
- Recommended 10-12 hrs

Minimum 6 hrs

Maximum 24 hrs

### **3) Constant-current charging method**

- Initial charging current: 1/10 of rating
- Charging time: Maximum 5 hrs

#### **WARNING**

**WHEN THE BATTERY IS DEEPLY DISCHARGED (FAR BELOW 12.6V), 5 HOURS' RECHARGING MAY NOT BE ENOUGH TO OBTAIN OPTIMUM PERFORMANCE. IN THESE CONDITIONS, HOWEVER, TO AVOID DAMAGING THE BATTERY BEYOND REPAIR, IT IS ESSENTIAL NOT TO RECHARGE IT FOR MORE THAN 8 CONSECUTIVE HOURS.**

---

---

## Dry-charge battery

### WARNING

**BATTERY ELECTROLYTE IS POISONOUS AND CAN CAUSE SERIOUS BURNS AS IT CONTAINS SULPHURIC ACID. AVOID CONTACT WITH THE EYES, THE SKIN AND GARMENTS. IN CASE OF CONTACT WITH THE EYES OR SKIN RINSE ABUNDANTLY WITH WATER FOR ABOUT 15 MINUTES AND SEEK IMMEDIATE MEDICAL ASSISTANCE.**

**IF THE LIQUID IS INGESTED IMMEDIATELY DRINK LARGE QUANTITIES OF WATER OR MILK. SUBSEQUENTLY DRINK MILK OF MAGNESIA, BEATEN EGG OR VEGETABLE OIL. CALL A DOCTOR WITHOUT DELAY.**

**BATTERIES PRODUCE EXPLOSIVE GASES. KEEP AWAY OPEN FLAMES, SPARKS AND CIGARETTES. WHEN A BATTERY IS CHARGED IN CLOSED PLACES ENSURE ADEQUATE VENTILATION.**

**ALWAYS PROTECT THE EYES WHEN WORKING IN THE PROXIMITY OF BATTERIES. POSITION THE TUBE BETWEEN THE MUDGUARD AND THE FILTER.**

**KEEP OUT OF REACH OF CHILDREN.**

---

1) - Remove the short closed tube and the plugs. Fill the cells to the upper level with battery acid, specific gravity 1.26 corresponding to 30° Bé at 15°C.

2) - Leave the battery to stand for about 2 hours and then top up once again with battery acid.

3) - Within 24 hours, recharge the battery using the specific battery charger 020333Y (single) or 020334Y (multiple). Apply an intensity equivalent to about 1/10 of the battery rating until the acid density is approximately 1.27, corresponding to 31° Bé, and these values stabilize.

4) - When the battery is fully charged, top up with **distilled water**, refit the plugs and clean the battery case.

5) - After completing the above operations, proceed to install the battery on the vehicle, taking care to observe the connections between the wiring and the battery terminals.

### WARNING

**AFTER INSTALLING THE BATTERY AND IN ORDER TO PROVIDE A VENT FOR THE GASES FORMING INSIDE IT, REPLACE THE SHORT CLOSED TUBE NEXT TO THE POSITIVE (+) TERMINAL WITH THE CORRESPONDING LONG OPEN TUBE WHICH IS PRESENT ON THE VEHICLE. CHECK THAT THE TUBE SLOTS ARE TURNED TO THE BATTERY SIDE**

## Specific tooling

**020333Y Single battery charger**

**020334Y Multiple battery charger**

---

The battery is the electrical component which requires the most constant care and accurate maintenance. The main maintenance rules are as fol-

---

lows:

### 1) Checking the electrolyte level

Frequently check that the electrolyte reaches the upper level. To top up, only use distilled water. If you need to top up the battery too frequently, check the vehicle electrical equipment as the battery is certainly working in overload conditions, which will lead to rapid deterioration.

### 2) Checking the battery charge

After restoring the electrolyte level, check its density with the special hydrometer (see figure). When the battery is charged, electrolyte density must be between 30 and 32 Bé, corresponding to specific gravity of 1.26-1.28 at a temperature not lower than 15°C.

If density has fallen below 20° Bé, the battery is completely discharged and needs recharging. At the end of the charging, check the level and density of the electrolyte in each cell. If the vehicle is not used for some time (1 month or more) the battery must be periodically recharged. In three months the battery runs down completely.

When reinstalling the battery on the vehicle, take care not to invert the connections. The black (-) earth wire must be connected to the negative (-) terminal whereas the two red (+) wires must be connected to the positive (+) terminal.

Normal bench charging must be carried out with the specific battery charge (single) or (multiple). Choose the charger setting corresponding to the type of battery to be recharged. Ensure you connect up to the battery with the correct polarity (+ to + and - to -). The plugs must be removed from the battery throughout the charging procedure.

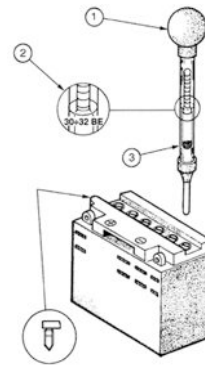

#### 4) Cleaning the battery

Keep the battery clean, especially the top; coat the terminals with Vaseline.

##### **WARNING**

**BEFORE CHARGING THE BATTERY REMOVE ALL CELL PLUGS. KEEP FREE FLAMES OR SPARKS AWAY FROM THE BATTERY DURING RECHARGE.**

**WHEN THE BATTERY HAS TO BE REMOVED FROM THE VEHICLE, DISCONNECT THE NEGATIVE TERMINAL FIRST.**

##### **CAUTION**

**NEVER USE FUSES HAVING A GREATER CAPACITY THAN THE ONE RECOMMENDED. THE USE OF A FUSE OF UNSUITABLE CAPACITY MAY RESULT IN SERIOUS DAMAGE TO THE WHOLE VEHICLE OR EVEN CAUSE A FIRE.**

##### **CAUTION**

**NORMAL DRINKING WATER CONTAINS SALTS THAT ARE HARMFUL FOR BATTERIES. USE ONLY DISTILLED WATER.**

##### **CAUTION**

**TO ENSURE MAXIMUM PERFORMANCE THE BATTERY MUST BE CHARGED BEFORE USING THE VEHICLE.**

**INSUFFICIENT BATTERY CHARGE OR LOW ELECTROLYTE LEVEL WHEN FIRST USED WILL RESULT IN PREMATURE FAILURE OF THE BATTERY.**

#### Specific tooling

020333Y Single battery charger

020334Y Multiple battery charger

---

## INDEX OF TOPICS

ENGINE FROM VEHICLE

ENG VE

---

## Exhaust assy. Removal

---

- Remove the two nuts securing the manifold to the head

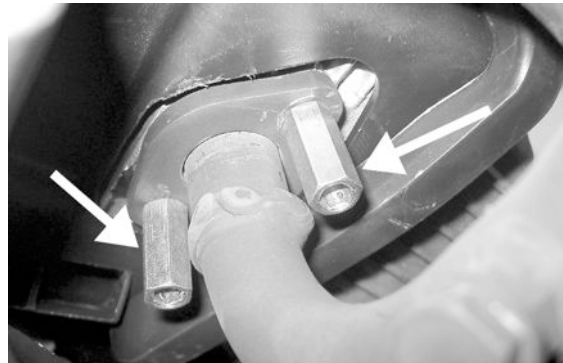

- Unscrew the two screws securing the silencer to the crankcase then remove the complete muffler paying attention to the interference between its support bracket and the cooling casing.

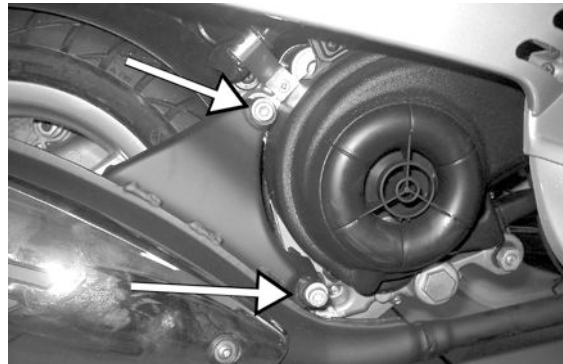

---

## Removal of the engine from the vehicle

### Removing the engine from the frame

---

- Disconnect the battery.
- Remove the exhaust pipe assembly.
- Remove the rear wheel.
- Remove the rear brake cable.
- Detach the electrical terminals.
- Remove the throttle cable.
- Detach the tubing (fuel - vacuum tap).
- Disconnect the engine from the swing-arm.
- Disconnect the lower fixing on the rear shock-absorber.

#### **WARNING**

**HANDLE PETROL WITH THE UTMOST CARE.**

#### **CAUTION**

**WHEN INSTALLING THE BATTERY ALWAYS CONNECT THE POSITIVE LEAD BEFORE THE NEGATIVE LEAD.**

---



**WARNING**

**WEAR PROTECTIVE GOGGLES WHEN USING HAMMERING TOOLS.**

---



## INDEX OF TOPICS

ENGINE

ENG

---

## Automatic transmission

---

### Transmission cover

---

- Remove the 12 screws.
  - Remove the cap/bar of the engine oil filling hole.
- If this operation is performed directly on the vehicle, it is necessary to remove the transmission compartment cooling air sleeve first.

**N.B.**

**TO REMOVE THE COVER, USE A MALLET ON THE SPECIALLY DESIGNED PROJECTIONS.**

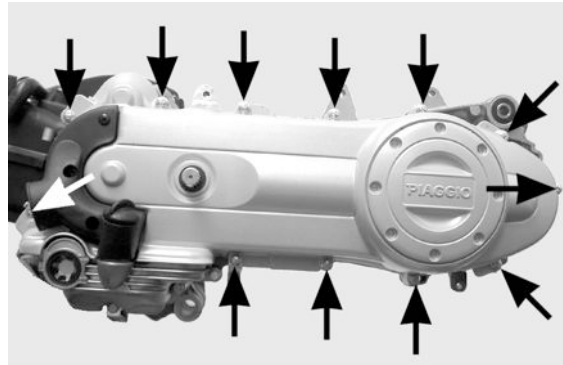

---

### Kickstart

---

- Remove the starter pinion. Press the kick-start to facilitate the ejection of the pinion.
- Remove the screw and the kick-start.
- Remove the seeger ring and the washer shown in the figure.
- Remove the sector gear.

**WARNING**

**THE SECTOR GEAR MAINTAINS THE SPRING LOADED. TAKE CARE TO AVOID ACCIDENTS.**



---

### Air duct

---

- To remove the air inlet from the transmission cover, simply loosen the three screws shown in the figure.

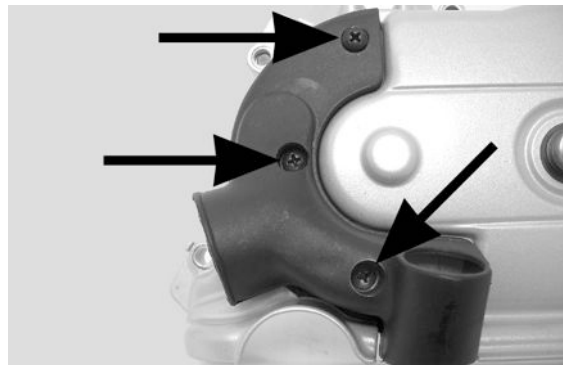

---

## Removing the driven pulley shaft bearing

---

- Slightly heat the crankcase on the inside to avoid damaging the painted surface. Remove the bearing using the driven pulley shaft or a pin of the same diameter.

**N.B.**

**IF THIS IS DIFFICULT A GENERIC 8 MM EXTRACTOR FOR INNER PARTS CAN BE USED.**

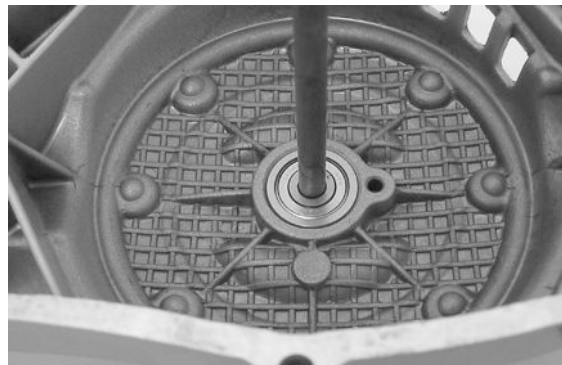

---

## Refitting the driven pulley shaft bearing

- Reassemble the bearing using a bushing of the same diameter as the outer race of the bearing, after having slightly heated the crankcase on the inner side.

**N.B.**

**WHEN REFITTING, ALWAYS REPLACE THE BEARING WITH A NEW ONE.**

**CAUTION**

**BE CAREFUL NOT TO DAMAGE THE PAINT JOB ON THE COVER WHEN DISASSEMBLING/REASSEMBLING THE BEARING.**

---

## Removing the driven pulley

---

- Lock the clutch bell housing with the specific tool.
- Remove the nut, the clutch bell housing and the whole of the driven pulley assembly.

**N.B.**

**THE ASSEMBLY CAN ALSO BE REMOVED WITH THE DRIVE PULLEY IN PLACE.**



### Specific tooling

**020565Y Compass flywheel stop spanner**

---

## Inspecting the clutch drum

---

- To verify that the bell clutch is not usurata or damaged.

- To measure the inner diameter of the bell clutch.

### Characteristic

#### Clutch bell diameter/standard value

Ø 107+0,2 +0 mm

#### Clutch bell diameter/max. value allowed after use

Ø 107,5 mm

#### Found eccentricity /max.

0,20 mm



## Removing the clutch

- Set-up the equipment with the long pins screwed from the outside in position «A», insert the driven pulley unit in the equipment and screw down central screw.

### CAUTION

**OVERTIGHTENING OF THE CENTRAL SCREW CAUSES THE DISTORTION OF THE TOOL.**

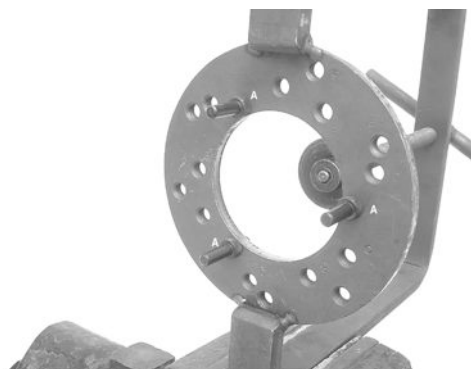

- Use a 34 mm Allen wrench to remove the nut securing the clutch.
- Loosen the central screw unloading the spring of the driven pulley unit
- Separate the parts.

### Specific tooling

**020444Y Driven half pulley spring compressor tool**

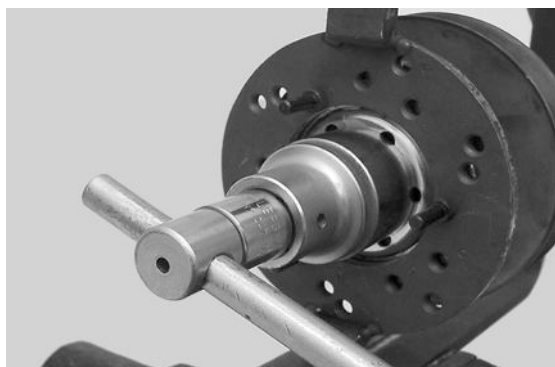

## Inspecting the clutch

- Check the thickness of the clutch mass friction material.
- The masses must exhibit no traces of lubricants; in that case, check the driven pulley unit seals.

**N.B.**

**UPON RUNNING-IN, THE MASSES MUST EXHIBIT A CENTRAL CONTACT SURFACE AND MUST NOT BE DIFFERENT FROM ONE ANOTHER. DIFFERENT CONDITIONS MAY CAUSE THE CLUTCH TEARING.**

**CAUTION**

**DO NOT OPEN THE MASSES USING TOOLS TO PREVENT A VARIATION IN THE RETURN SPRING LOAD.**

**Characteristic**

**Check . Minimum thickness**

1 mm

**Pin retaining collar**

- Remove the collar with the aid of two screwdrivers.

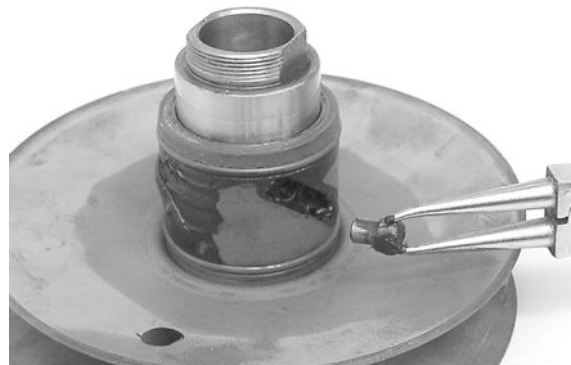

- Remove the three guide pins and the movable half pulley.

**Removing the driven half-pulley bearing**

- Remove the roller bearing using the specific extractor inserted from the lower side of the station-

ary half pulley

**CAUTION**

**POSITION THE SEALING EDGE OF THE EXTRACTION PLIERS BETWEEN THE END OF THE BEARING AND THE BUILT-IN SEAL RING.**

**Specific tooling**

**001467y029 Bell**



- Remove the snap ring from the roller bearing.
- Remove the roller bearing from the side of the clutch using the specific device.

**N.B.**

**ADEQUATELY SUPPORT THE HALF PULLEY TO PREVENT THE DRIVE BELT SLIDING SURFACE FROM BEING DISTORTED.**

**Specific tooling**

**020376Y Handle for punches**

**020363Y 20mm guide**



## Inspecting the driven fixed half-pulley

- Make sure there are no signs of wear on the work surface of the belts, if there are replace the half pulley.
- Make sure the bearing do not show signs of unusual wear.
- Measure the external diameter of the pulley bushing.

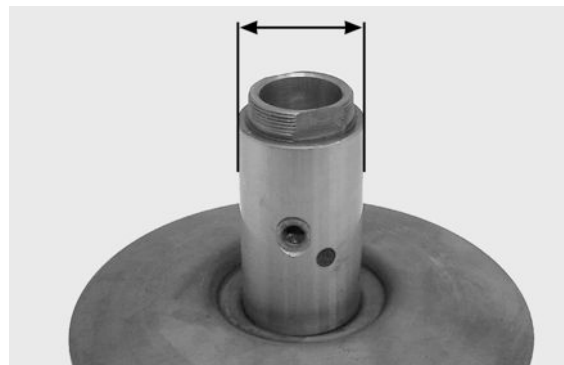

**Characteristic**

**Standard diameter**

Ø 33,965 ÷ 33,985 mm

**Stationary driven half pulley/ Minimum diameter allowed after use**

Ø 33,96 mm



---

## Inspecting the driven sliding half-pulley

---

- Remove the two inner seal rings and the two O-rings.
- Measure the inside diameter of the movable half pulley bushing.

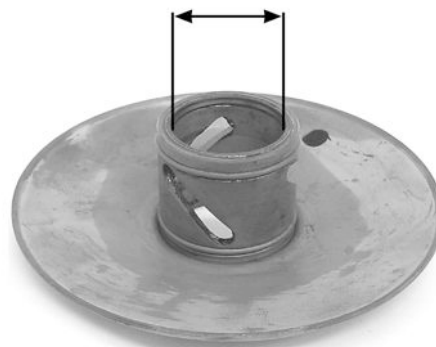

### Characteristic

#### Maximum allowable diameter

Ø 34,08 mm

- 
- Check the belt contact surfaces.
  - Insert the new oil guards and O-rings on the mobile half pulley.
  - Assemble the half pulley on the bushing.



### Recommended products

#### TUTELA MRM 2 Grease for the phonic wheel turning ring

Molybdenum disulphide grease and lithium soap

- Make sure the pins and collar are not worn, reassemble the pins and collar.
- Use a greaser with a curved spout to lubricate the driven pulley unit with around 6 gr. of grease, this operation must be carried out through one of the holes inside the bushing until grease comes out of the opposite hole. This operation is necessary to avoid the presence of grease beyond the O-rings.

### Recommended products

#### TUTELA MRM 2 Grease for the phonic wheel turning ring

Molybdenum disulphide grease and lithium soap

---

## Refitting the driven half-pulley bearing

---

- Fit a new ball bearing with the specific tools.
- Fit the ball bearing circlip.
- Fit the new roller bearing so that the lettering is visible from the outside.

### CAUTION

ADEQUATELY SUPPORT THE HALF PULLEY TO

---

**AVOID DAMAGING THE THREADED END WHILE FITTING THE BEARINGS.**

### Specific tooling

**020376Y** Handle for punches

**020456Y** Ø 24 mm adaptor

**020362y** 12 mm guide

**020171y** Roller bearing drift



---

## Inspecting the clutch spring

- Make sure that the driven pulley contrast spring is not deformed.
- Minimum length allowed after use

### Characteristic

#### Standard length

118 mm

#### Limit after use

XXXX

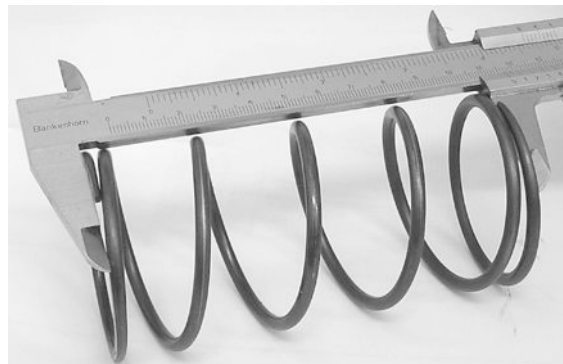

- Measure the thickness of the friction material on the clutch weights.
- The clutch weights should bear no traces of lubricants. If they do, check the driven pulley assembly.

**N.B.**

**DURING THE RUNNING-IN PERIOD, THE CLUTCH WEIGHTS MUST HAVE A CENTRAL CONTACT SURFACE AND MUST NOT DIFFER FROM ONE ANOTHER, OTHERWISE THE CLUTCH MAY GRAP.**

### CAUTION

**DO NOT USE ANY TOOLS TO OPEN THE WEIGHTS AS THIS MAY CHANGE THE LOAD OF THE RETURN SPRINGS.**

### Characteristic

**Minimum allowable thickness:**



---

1 mm

---

## Refitting the clutch

---

- Preassemble the driven pulley unit with spring, sheathing and clutch.
- Position the spring with the plastic shielding supporting the clutch
- Insert the parts in the device and preload the spring, being careful not to damage the plastic sheathing and the end of the threaded shank.

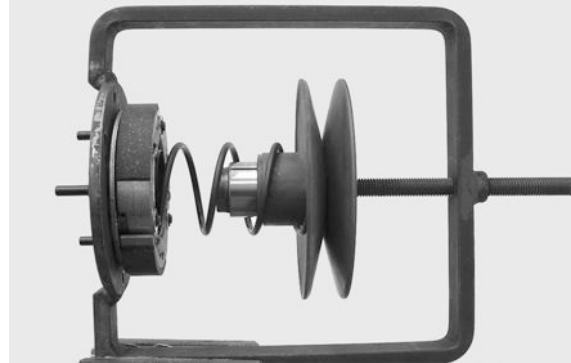

- Reassemble the nut securing the clutch and tighten to the prescribed torque.

### CAUTION

**TO AVOID DAMAGING THE CLUTCH NUT, USE A SOCKET WRENCH WITH A SMALL BEVEL.**

### CAUTION

**POSITION THE UNBEVELLED SURFACE OF THE NUT IN CONTACT WITH THE CLUTCH.**

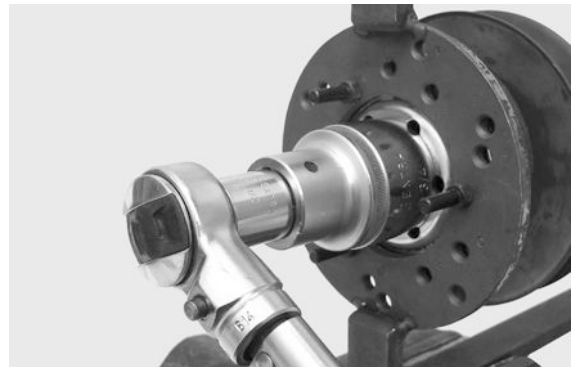

### Locking torques (N\*m)

**Nut locking clutch assembly on pulley 55 ÷ 60 Nm**

---

## Refitting the driven pulley

---

- Fit the driven pulley assembly, the clutch bell housing and the nut using the specific tool.

### Specific tooling

**020565Y Compass flywheel stop spanner**

### Locking torques (N\*m)

**Driven pulley shaft nut 40 -÷ 44 Nm**

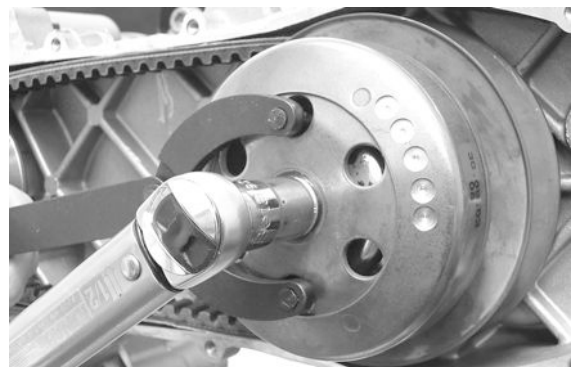



---

## Drive-belt

---

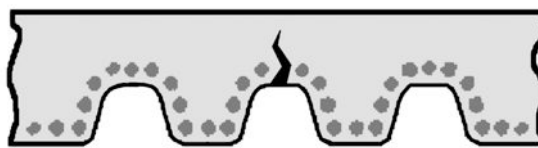
- Make sure the transmission belt is not damaged and does not have cracks in the toothed grooves.
- Check the width of the belt.



### Characteristic

transmission belt/Minimum width

17,5 mm



## Removing the driving pulley

- Lock the pulley with the specific tool.
- Remove the central nut with the related washer, then remove the drive and the plastic fan.
- Remove the fixed half pulley.

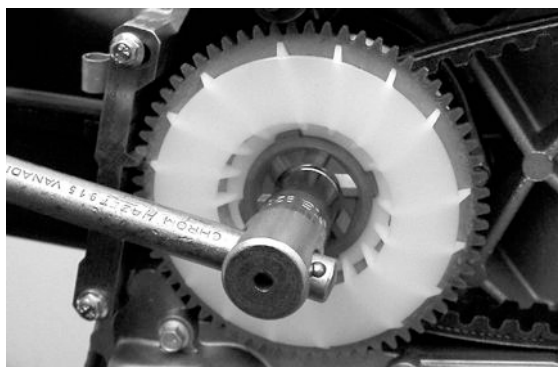

- Remove the belt, washer and remove the mobile half pulley with its bushing, being careful of the rollers and contrast plate fitted loosely on it.

### Specific tooling

020451y Drive pulley stop spanner

## Inspecting the rollers case

- 1) Make sure that the bushing and sliding rings on the mobile pulley are not lined or deformed.
- 2) Check the track where the rollers slide on the contact pulley, there should not be any signs of wear and check the conditions of the belt contact surfaces on the half pulleys (mobile and stationary).
- 3) Make sure that the rollers do not have marked facing on the sliding surfaces and that the metal insert does not protrude from the edges of the

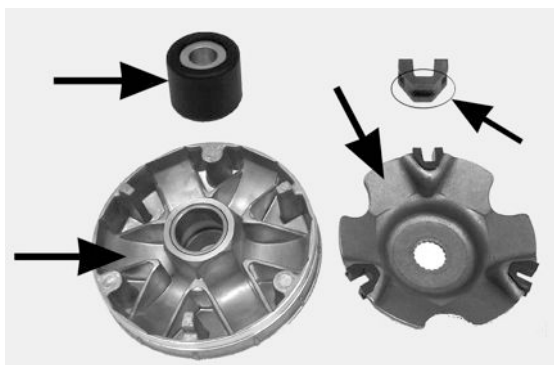

plastic cover.

4) Make sure that the contact plate sliding blocks are intact.

- Check that the internal bronze bushing shown in the figure is not abnormally worn and measure inside diameter «A».

- Measure outside diameter «B» of the pulley sliding bushing shown in the figure.

**CAUTION**

**DO NOT LUBRICATE OR CLEAN THE BRONZE BUSHING.**

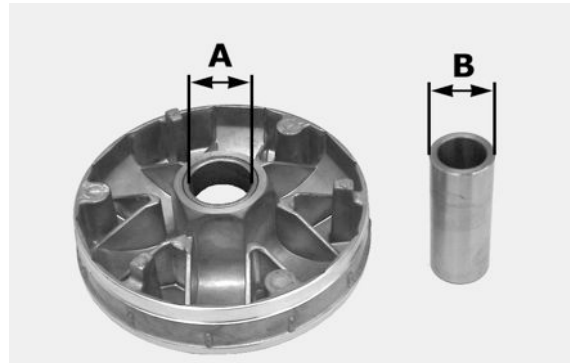

**Characteristic**

**Maximum allowable diameter:**

20,12 mm

**Standard diameter:**

20,021 mm

**Sliding pulley brass/ Diameter maximum:**

XXX mm

**Sliding pulley brass/ Standard diameter:**

XXX mm

**Refitting the driving pulley**

- Manually move the mobile driven pulley by pulling it towards the clutch unit and insert the belt keeping the rotation direction of the first assembly.

**N.B.**

**IT IS ALWAYS A GOOD IDEA TO FIT THE BELT SO THAT THE WORDS ARE LEGIBLE IN CASE THE BELT DOES NOT SHOW AN ASSEMBLY DIRECTION.**



- Reassemble the unit parts (roller housing unit with bushing, washer, stationary half pulley, belt

cooling fan with intake, washer and nut).

- Tighten the nut to a torque of 20 Nm and then finally tighten 90° with the specific tool preventing rotation of the drive pulley.

**N.B.**

**REPLACE THE NUT WITH A NEW ONE EVERY TIME THE PARTS ARE REASSEMBLED**

**CAUTION**

**IT IS VERY IMPORTANT THAT WHEN THE DRIVE PULLEY IS SECURED THAT THE BELT IS FREE INSIDE IT, TO AVOID INCORRECTLY TIGHTENING IT WITH LATER DAMAGE TO THE ENGINE SHAFT MM SCALE.**



**Specific tooling**

**020451y Drive pulley stop spanner**

**Locking torques (N\*m)**

**Tightening torque plus angle 18 ÷ 20 + 90°  
N.m**

---

**Refitting the transmission cover**

---

- Check the sector gear, the sector gear spindle, the housing bush in the cover, the pinion shaft and the related seat in the crankcase, and the return spring for signs of wear.
- Replace any damaged parts.
- Lubricate the spring.
- Refit the sector gear and load the spring using the specially designed tool.
- Fit the washer, the seeger ring and the kick-start.

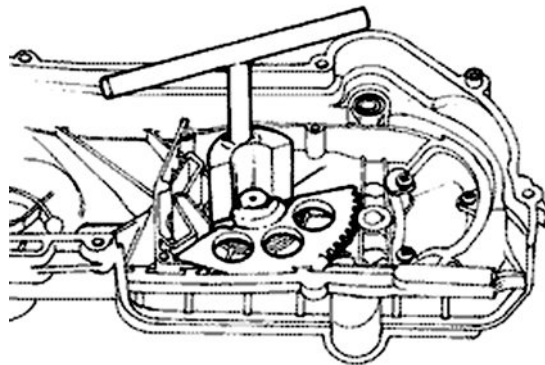

**Recommended products**

**JOTA 3 FS Speedometer transmission**

Lithium soap grease NLGI 33

- Insert the pinion in its seat by pressing on the starter lever.
- Fit the suction intake and secure the 3 screws.

- Make sure of the presence of the dowel bolts and the sealing washer on the oil sump.
- Fit the transmission cover and tighten the 12 screws with the prescribed torque.
- Fit the oil filler plug.

### Locking torques (N\*m)

Transmission cover screw 11 ÷ 13 Nm

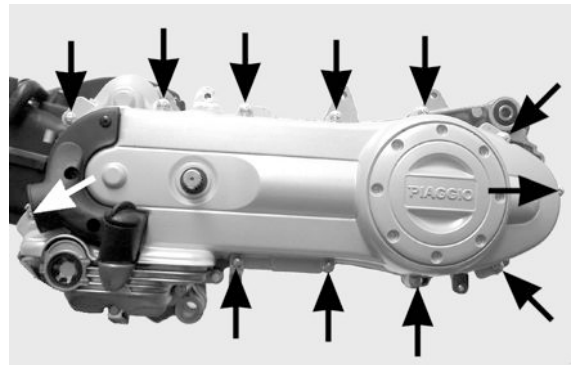

## End gear

### Removing the hub cover

- Remove the transmission cover.
- Remove the Driven pulley removal
- Discharge the rear hub oil.
- Remove the 5 screws indicated in the figure.
- Remove the hub cover with pulley shaft.

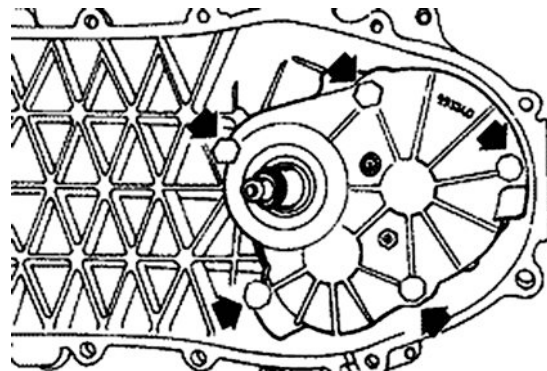

### See also

[Refitting the clutch](#)

### Removing the wheel axle

- Remove the idler gear and the wheel spindle with the related gear.
- While removing the idler gear, pay attention to the related shoulders.

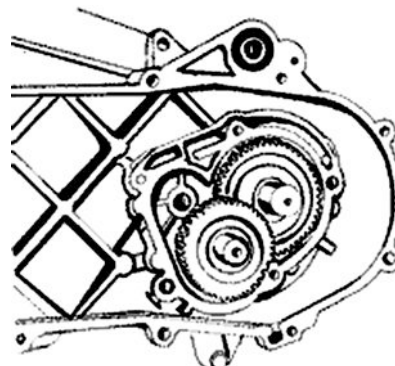

### Removing the wheel axle bearings

- Remove the oil seal and the seeger ring.
- Remove the bearing by pushing it with the specially designed drift from the outside towards the inside of the gear compartment.

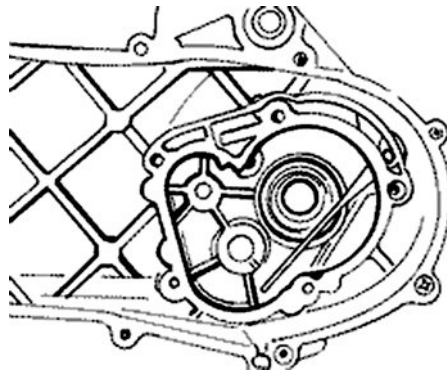

### Specific tooling

**020363Y 20mm guide**

**020376Y Handle for punches**

**020358y 37 x40 adaptor**

## Removing the driven pulley shaft bearing

- Remove the seeger ring from inside the cover.
- Remove the oil seal from the outside.
- Remove the two dowel bolts and place the cover on a horizontal surface.
- Position the specific tool on the inner race of the bearing and expel the bearing with the aid of a press.

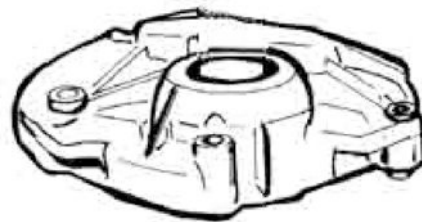

### Specific tooling

**020452y Driven pulley shaft fitting/removing tube**

- Position the specific tube on the inner race of the bearing and on the pulley shaft teeth side as shown in the figure. Expel the driven pulley shaft with the aid of a press.

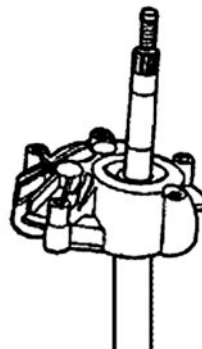

### Specific tooling

**020452y Driven pulley shaft fitting/removing tube**

## Inspecting the hub shaft

- Make sure the three shafts are not worn or deformed on the toothed surfaces, bearing and oil



guard spans.

- If faults are discovered replace the damaged parts.
- Check the span (A) of the counter gear (wear, lines etc.)
- Check the seat of the pulley shaft: Worn surfaces (B) can indicate irregularity in the seats on the chassis or in the pulley shaft span

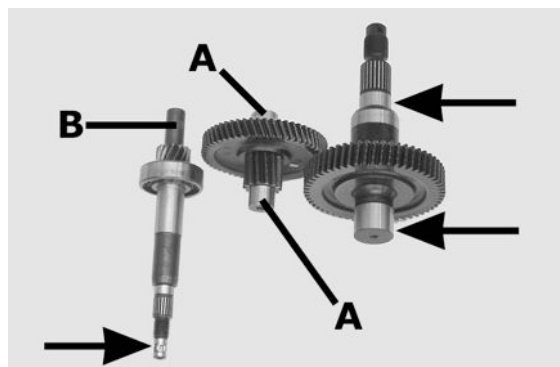

### Inspecting the hub cover

- Make sure the coupling surface is not dented or deformed.
- If faults are discovered replace the hub cover.

### Refitting the driven pulley shaft bearing

- Using the specific tool under the press, support the inner race of the bearing on the outside of the hub cover. Fit the driven pulley shaft.
- Fit the oil seal so it is flush with the cover.

#### Specific tooling

**020452y Driven pulley shaft fitting/removing tube**

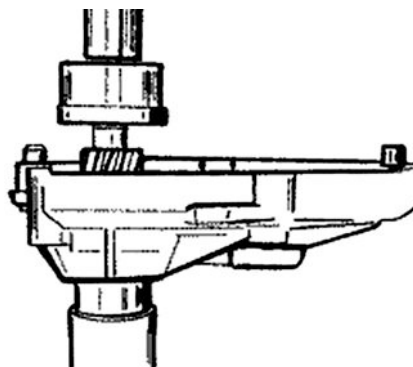

- Heat the hub cover and insert the bearing using the specific punch.
- Fit the elastic ring with the concave part on the bearing side.

**N.B.**

**FIT THE BALL BEARING WITH THE SHIELD FACING THE OIL SEAL.**

#### Specific tooling

**020151Y Air heater "METABO HG 1500/2"**

**020376Y Handle for punches**

**020439Y 17 mm guide**

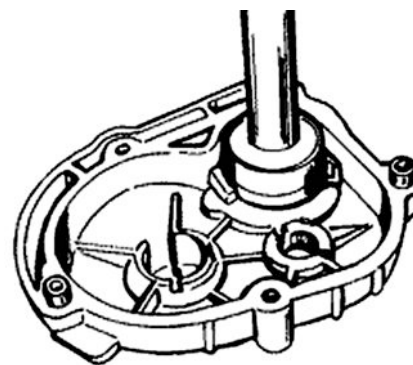

---

020358y 37 x40 adaptor

---

## Refitting the wheel axle bearing

---

- Heat the crankcase on the clutch side with the thermal gun.
- After lubricating the bearing outer plate, fit the bearing using the specially designed adaptor with the aid of a hammer.
- Fit the seeger ring and the oil ring using the 42x47 adaptor and the handle.

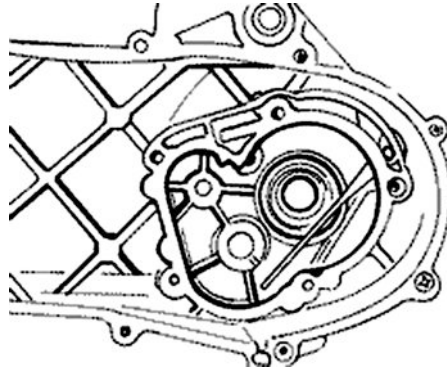

### Specific tooling

020151Y Air heater "METABO HG 1500/2"

020376Y Handle for punches

020363Y 20mm guide

020359Y 42 x 47 mm hub bearing fitting adaptor

---

## Refitting the hub cover

---

- Refit the wheel axle assembly.
- Refit the intermediate gear paying attention to the two shim washers.
- Apply LOCTITE 510 on the hub cover and refit it with driven pulley shaft.
- Refit the 5 screws and tighten to the prescribed torque.

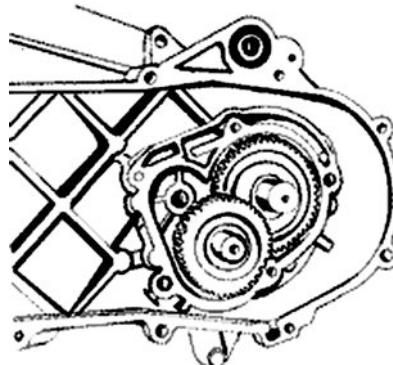

**N.B.**

**BEFORE FITTING A NEW GASKET, REMOVE ANY RESIDUES OF THE OLD GASKET FROM THE MATING SURFACES OF THE HUB COVER AND THE CRANKCASE HALF.**

### Locking torques (N\*m)

Tightening torque: 11 ÷ 13 N·m

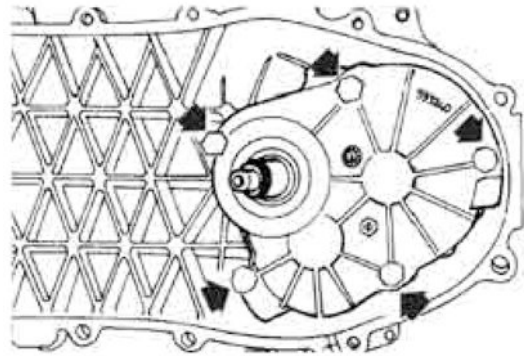

## Flywheel cover

### Cooling hood

- Remove the manifold with the carburetor using the 2 screws securing it to the head
- Remove the band securing the secondary air hose and disconnect it
- Remove the 4 screws connecting the front pieces (1 is a knob) and the side screw at the base of the chassis.
- Remove the 4 side screws
- Remove the 3 casings
- Remove the casing seal on the head
- Repeat the same steps in reverse order to reassemble

#### CAUTION

**TAKE CARE TO CORRECTLY POSITION THE FLY-WHEEL CONNECTOR.**

#### N.B.

**WHILE REMOVING THE COVER, TAKE CARE NOT TO DAMAGE THE WIRING OF THE STATOR.**

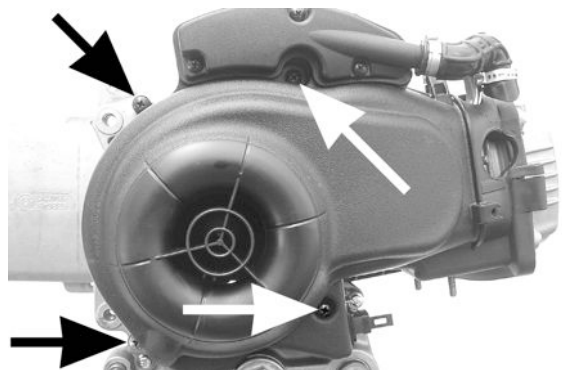
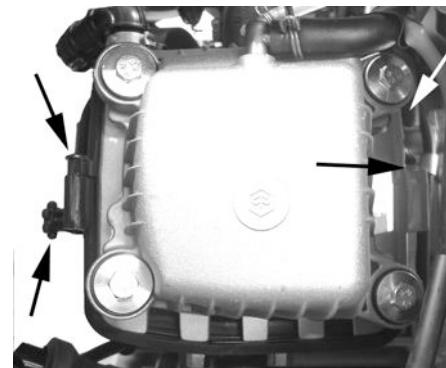
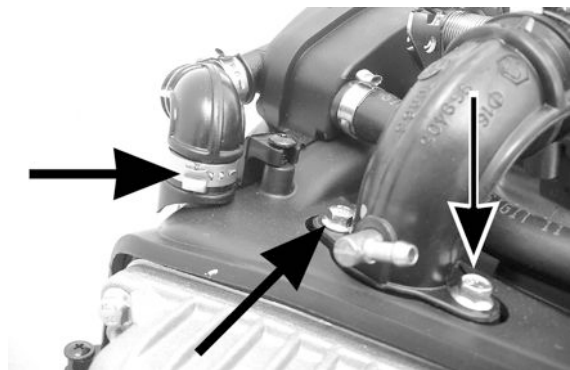

---

## Cooling fan

- Remove the fan using the 3 screws securing it to the rotor
- When reassembling be careful to line up the fan holes with the rotor, then tighten to the prescribed torque.

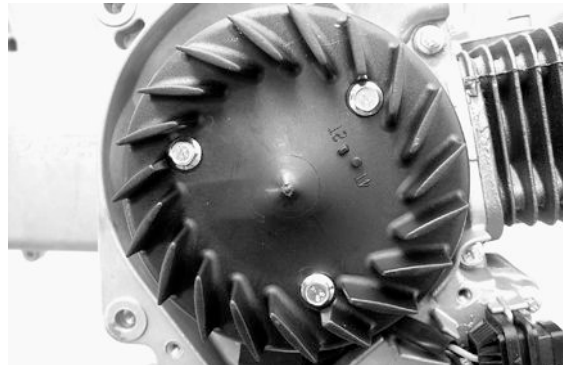

---

## Removing the stator

- Remove the two pick-up screws and the two stator fixing screws shown in the figure.
- Remove the stator and its wiring.

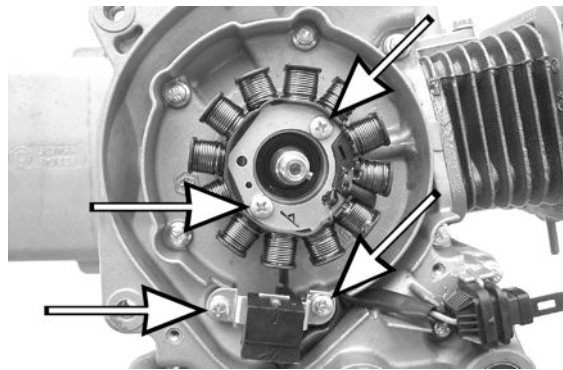



---

## Refitting the stator

- Fit the stator and the flywheel by following the reverse procedure to the removal. Tighten the fastenings with the prescribed torque.

**N.B.**

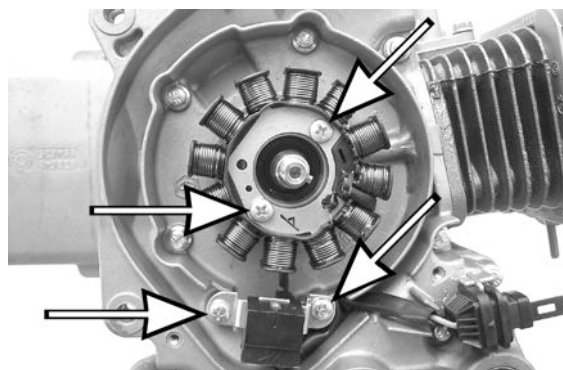
**THE PICK-UP WIRE MUST BE POSITIONED SO THAT IT TOUCHES THE CAST TAB ON THE CRANKCASE. THIS WILL PREVENT IT FROM BEING CRUSHED BY THE FAN COVER ASSEMBLY.**



### Locking torques (N\*m)

Pick-up screws 3 ÷ 4 Stator screws 3 ÷ 4

---

## Flywheel and starting

---

---

## Removing the starter motor

---

- Remove the fan using the 3 screws securing it to the rotor
- When reassembling be careful to line up the fan holes with the rotor, then tighten to the prescribed torque.

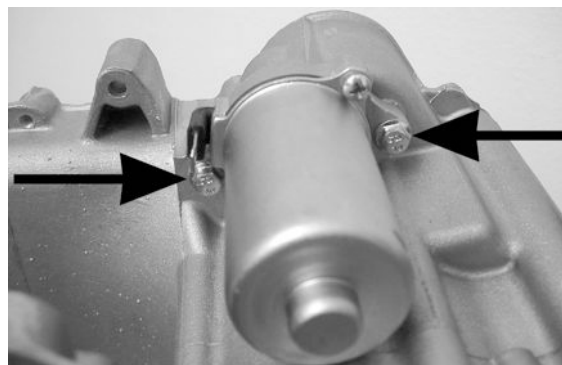
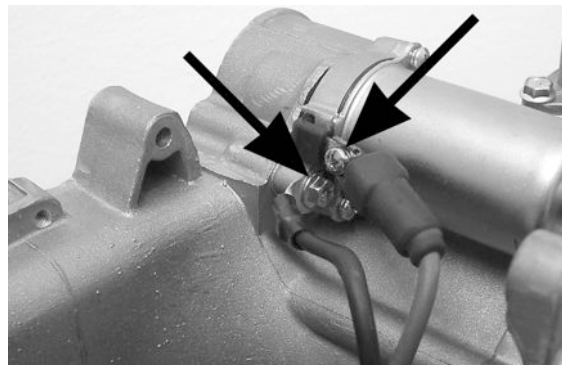

---

## Removing the flywheel magneto

---

- Lock the flywheel using the compass spanner.
- Remove the nut.

**CAUTION**

**USING A COMPASS SPANNER OTHER THAN THE ONE PROVIDED CAN DAMAGE THE STATOR COILS.**



- Extract the flywheel with the specially designed extractor.

### Specific tooling

**020565Y Compass flywheel stop spanner**

**020162y Flywheel extractor**

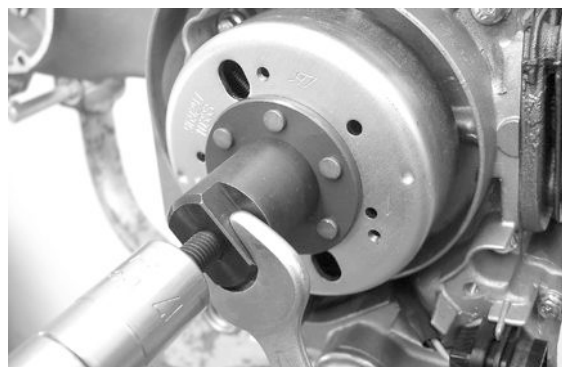

### Inspecting the flywheel components

---

- Make sure the magnetos inside the flywheel are intact.
- Make sure that the flywheel riveting is not loose.
- Make sure that there are no deformations which could cause rubbing on the stator and Pick-Up.
- Make sure the stator windings are intact as well as the ferromagnetic support and pick-up.



### Starter gear rim

---

- Make sure the teeth are intact and level



### Intermediate gear

---

- Make sure the tothing on the crown keying and on the starter motor are intact.
- Make sure the bendix opens and returns.



### Refitting the flywheel magneto

---

- Refit the stator and pick-up being careful to run the wiring in the specific chassis parts.
- Reassemble the flywheel on the engine shaft in-

serting it as forced by the cotter and lock the rotation with the specific tool and screw down the nut to the prescribed torque.

**N.B.**

**A CHANGE IN THE AIR GAP MAY ALTER THE SPARK ADVANCE AND CAUSE KNOCKING, ETC.**

### Specific tooling

**020565Y Compass flywheel stop spanner**

### Locking torques (N\*m)

**Flywheel nut 52 ÷ 58**

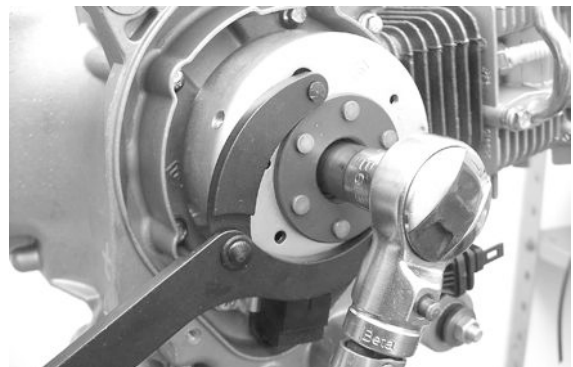
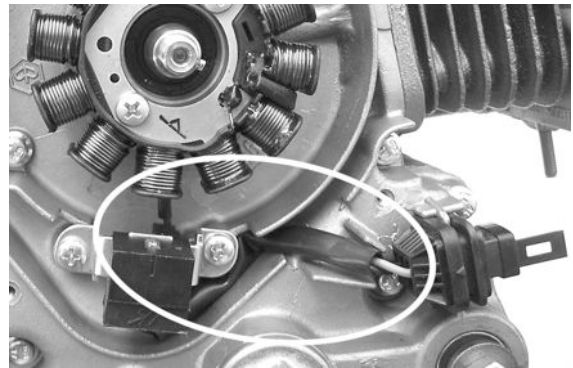

## Refitting the starter motor

- Fit the starter motor in its seat in the chassis.
- Screw the screw on the head side without completely tightening it, screw the other screw inserting it in the ground wire (black), then tighten the two screws to the prescribed torque.
- Tighten the set screws on the positive wire (red) on the contact.

**N.B.**

**FIT THE REMAINING PARTS AS DESCRIBED IN THE CHAPTERS CYLINDER, CYLINDER HEAD, VALVE GEAR, LUBRICATION, FLYWHEEL AND TRANSMISSION.**

### Locking torques (N\*m)

**Starter motor screws 11 ÷ 13**

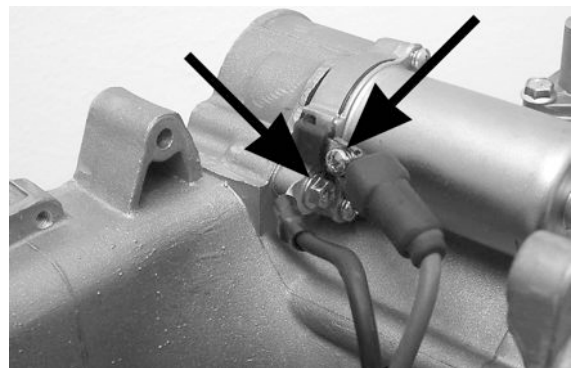

## Cylinder assy. and timing system

### Removing the rocker-arms cover

- Remove the coiling casings
- Remove the 4 screws from the tappet cover
- Remove the cover including the O-ring
- Remove the 4 screws and then the Blow-by cover
- Clean the nozzle labyrinth and the membrane, if necessary replace it, then refit the unit on the cover.

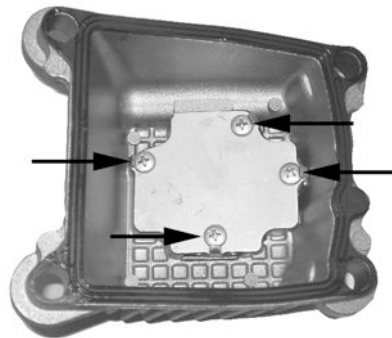
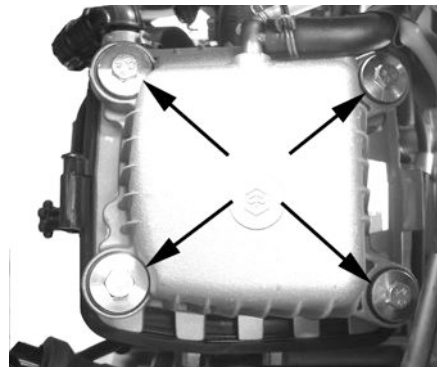

### Removing the timing system drive

- First loosen the central screw of the idler and remove it together with the spring.
- Unscrew the 2 screws shown in the figure and remove the chain idler support making sure to keep the seal.

**N.B.**

**IF THE SEAL IS NOT IN EXCELLENT CONDITION REPLACE AFTER HAVING ACCURATELY CLEANED THE CONTACT SURFACES IN ORDER NOT TO CAUSE ENGINE OIL LEAKAGE.**

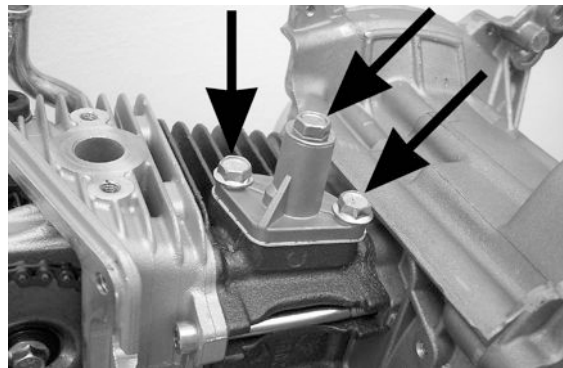

- Remove the drive pulley
- Remove the oil pump chain
- Remove the tappet cover
- Remove the central screw and the Belleville washer indicated in the figure by tightening the cam shaft crown with the specific tool.

**N.B.**

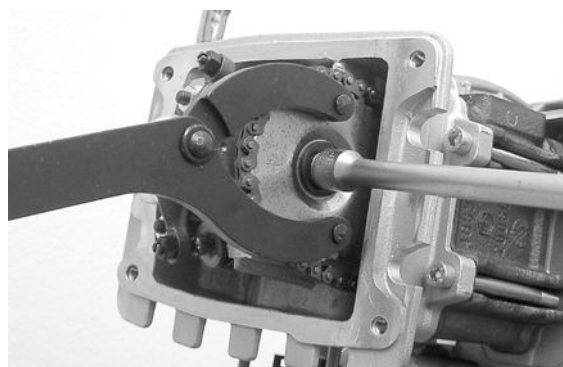



TO FACILITATE THE REMOVAL OF THE CYLINDER HEAD COMPONENTS, IT IS ADVISABLE TO BRING THE CRANKSHAFT TO THE TDC, AT THE END OF THE COMPRESSION STROKE. SPECIFIC TOOL

### Specific tooling

#### 020565Y Compass flywheel stop spanner

- Remove the cam shaft control pulley and the spacer under it.
- Remove the engine shaft distribution control pinion
- To remove the lower chain guide block, it is possible to operate from the head and pull it up

**N.B.**

THE CHAIN SHOULD BE SUITABLY MARKED TO ENSURE THAT THE ORIGINAL DIRECTION OF ROTATION IS MAINTAINED.

### See also

[Removing the driving pulley](#)

[Removing the rocker-arms cover](#)

[Removal](#)

## Removing the cam shaft

- Remove the bearing check screw shown in the figure.

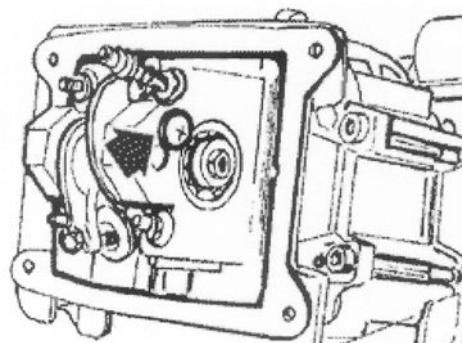

- Remove the camshaft complete with the bearing using the specific tool shown in the figure.
- Eject the bearing from the camshaft using the specific tool and taking care to fit a screw on the camshaft so as to protect the camshaft thread.

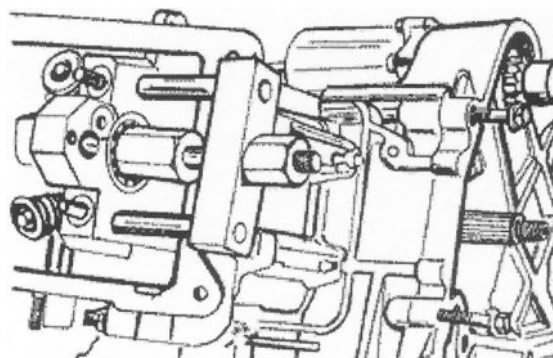

**N.B.**

WHENEVER THE BEARING IS SEPARATED FROM THE CAMSHAFT, REPLACE IT WITH A NEW ONE.

### Specific tooling

**020450y Camshaft fitting/removing tool**

**004499y Bearing extractor**

**004499y001 Bearing extractor fitted with parts**

**004499y002 Bearing extractor fitted with parts**

**004499y006 Bearing extractor fitted with parts**

**004499y027 Bearing extractor fitted with parts**

- Remove the rocker arm pivot through the hole on the flywheel side and simultaneously remove the rocker arms.

**N.B.**

**MARK THE INSTALLING POSITION OF EACH ROCKER ARM SO AS TO AVOID FITTING THE INTAKE ROCKER ARM IN PLACE OF THE EXHAUST ROCKER ARM OR VICE VERSA.**

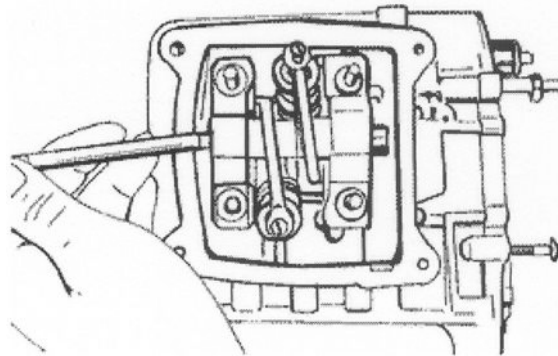

## Removing the cylinder head

- Remove the cooling hoods, the valve gear drive, the camshaft and the rocker arms.

- Remove the spark plug.

- Remove the two side fastenings shown in the figure.

- Loosen the four cylinder head locknuts in two or three phases Following a crosswise pattern.

- Remove the cylinder head, the two dowel bolts and the gasket.

**N.B.**

**IF NECESSARY, THE CYLINDER HEAD CAN BE REMOVED COMPLETE WITH THE CAMSHAFT, THE ROCKER ARM PIVOT AND WITHOUT REMOVING THE DRIVE PULLEY ASSEMBLY. HOWEVER, IT IS ESSENTIAL TO SUPPORT THE TIMING CHAIN WITH A LENGTH OF WIRE AND TO ADJUST THE CHAIN TENSIONER AS DESCRIBED ON AFTER RE-ASSEMBLY.**

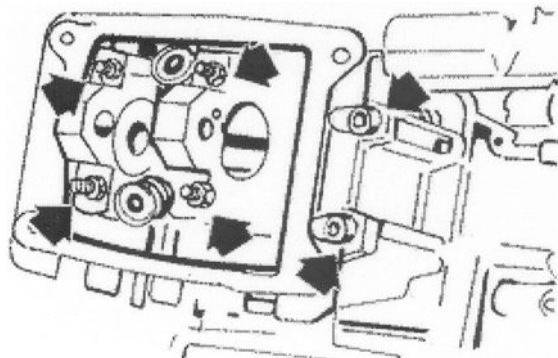

## Removing the valves

- Using the specific tool with the part shown in the figure, remove the cotter halves, the caps and the springs from both valves.

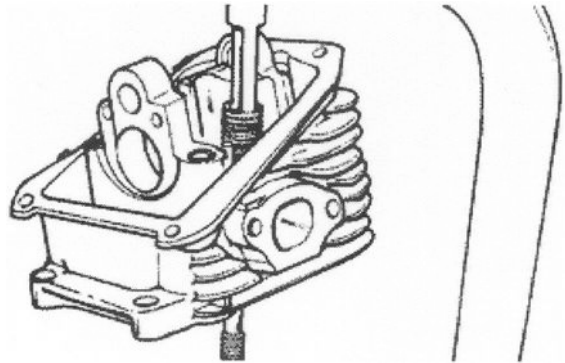

- Remove the oil seals with the specific tool.
- Remove the lower spring supports.

### Specific tooling

020431Y Valve oil seal extractor

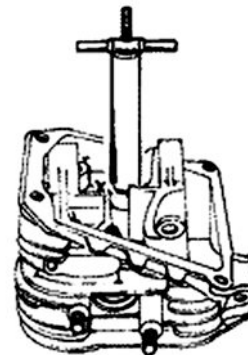

## Removing the cylinder - piston assy.

- Remove the cylinder paying attention to the two cylinder dowel bolts on the crankcase.
- Remove the cylinder base gasket.
- To avoid damaging the piston, support it while removing the cylinder.

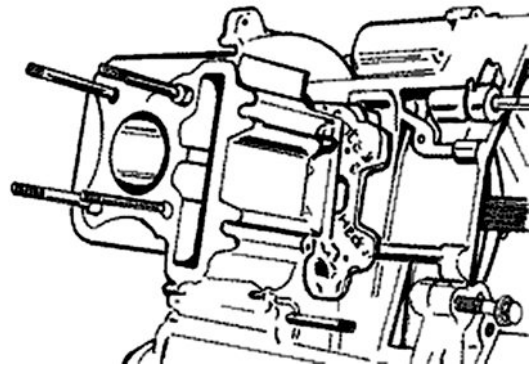

- Remove the two circlips, the piston pin and the piston.
- Remove the three piston rings.

**N.B.**

**TAKE CARE NOT TO DAMAGE THE PISTON RINGS WHILE REMOVING THEM.**

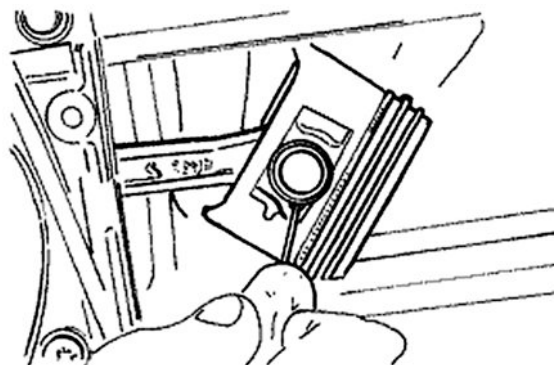

---



---

## Inspecting the small end

---

- Using an inside micrometer, measure the small end diameter.

**N.B.**

**IF THE SMALL END DIAMETER EXCEEDS THE MAXIMUM ALLOWABLE VALUE, OR IF IT SHOWS SIGNS OF WEAR OR OVERHEATING, PROCEED TO REPLACE THE CRANKSHAFT AS DESCRIBED IN THE CHAPTER "CRANKCASE AND CRANK-SHAFT".**

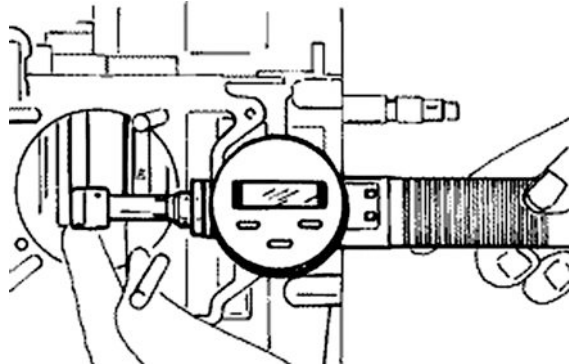

### Characteristic

#### Max. allowable diameter

13,030 mm

#### Standard diameter

13+0,025 +0,015 mm

---

## Inspecting the wrist pin

---

- Measure the piston pin outside diameter

### Characteristic

#### Standard diameter

13 -0 -0,004 mm

#### Minimum allowable diameter:

12,990 mm

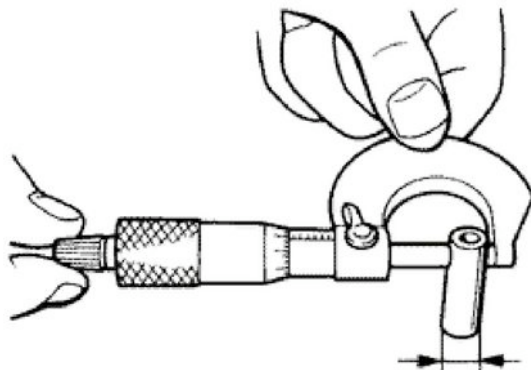

---

## Inspecting the piston

- Carefully clean the piston ring grooves using an old piston ring.

- Using a reed thickness gauge, measure the play between the piston rings and the grooves as shown in the figure.

- If any play is found to be greater than specified in the table below, replace the piston and the piston rings.

### PISTON

Name	Description	Dimensions	Initials	Quantity
1st ring		0,030 ÷ 0,065 mm		0,080 mm
2nd ring		0,020 ÷ 0,055 mm		0,070 mm
Scraper ring		0,040 ÷ 0,160 mm		0,20 mm

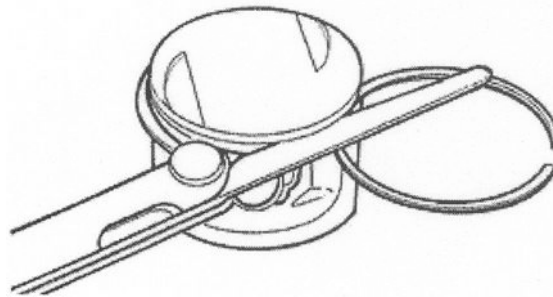

- Calculate the mating play between the piston pin and the piston.

**Fitting clearance**

**Piston standard diameter**  $13+0,010+0,005$  mm  
**0,005 ÷ 0,014 mm**

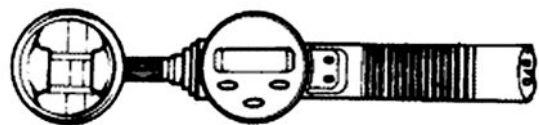

- Measure the piston outside diameter perpendicularly to the piston pin axis.
- Take the measurement 27 mm from the piston top as shown in the figure.

**Inspecting the cylinder**

- Using a bore meter, measure the cylinder inside diameter at three different heights in the directions shown in the figure.
- Check that the mating surface with the cylinder head is not worn or distorted.
- Pistons and cylinders are classified according to diameter. Mating is obtained by matching class letters (A-A, B-B, C-C, D-D).

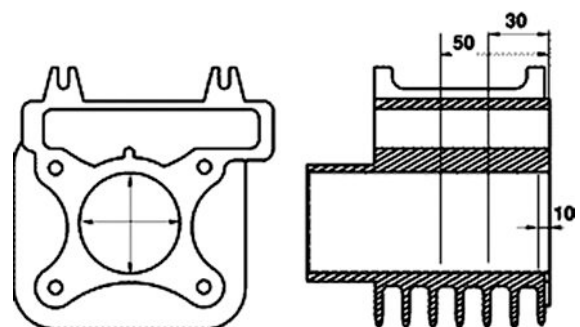

**Characteristic**

**Maximum allowable runout:**

0,05 mm

- The cylinder must be so ground that the finish has the same inclination as the original, i.e. 120 degrees crosswise.
- The cylinder surface must have a roughness of 0.30 - 0.50 R.A.
- This is necessary to obtain proper bedding of the piston rings, and ensure reduced oil consumption and excellent performance.
- Two classes of oversize pistons are supplied for cylinder grinding. The 1st and 2nd classes correspond to an oversize of 0.2 and 0.4 mm respectively. These are also classified in the four categories A-A, B-B, C-C and D-D.

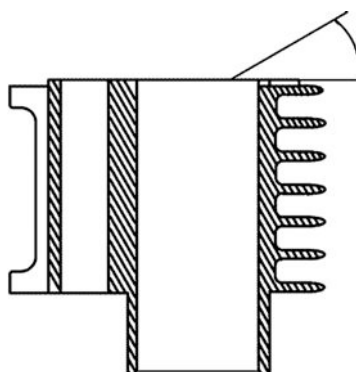

## Inspecting the piston rings

- Alternately insert the three piston rings into the cylinder, in the area where it retains its original diameter. Using the piston, insert the rings perpendicularly to the cylinder axis.
- Using a thickness gauge (see figure), measure the gaps of the piston rings.
- If any measurements are greater than prescribed, replace the piston rings.

### N.B.

**BEFORE REPLACING THE PISTON RINGS ONLY, ENSURE THAT THE CLEARANCE BETWEEN THE PISTON RINGS AND THE PISTON RING GROOVES, AND BETWEEN THE PISTON AND THE CYLINDER, IS AS SPECIFIED. IN ANY CASE, NEW PISTON RINGS USED IN COMBINATION WITH A USED CYLINDER MAY HAVE DIFFERENT BEDDING CONDITIONS THAN THE STANDARD.**

### SEAL RINGS

Name	Description	Dimensions	Initials	Quantity
1st ring		0,08 ÷ 0,20 mm		0,35 mm
2nd ring		0,05 ÷ 0,20 mm		0,30 mm
Scraper ring		0,20 ÷ 0,70 mm		0,80 mm

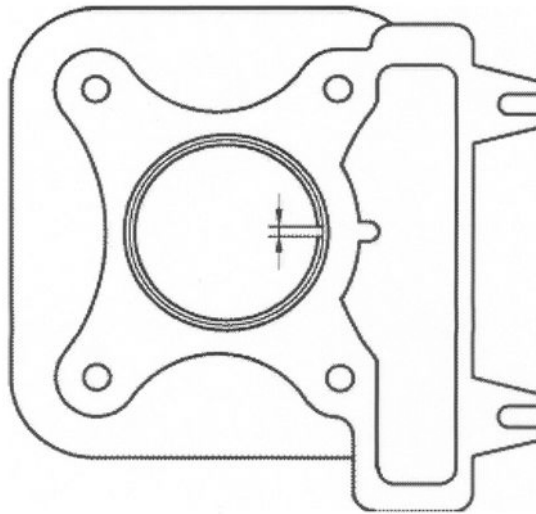

## Removing the piston

- Fit the piston and the piston pin to the connecting rod. The arrow on the piston must face the exhaust side.
- Insert the piston pin circlip into the specially designed tool.

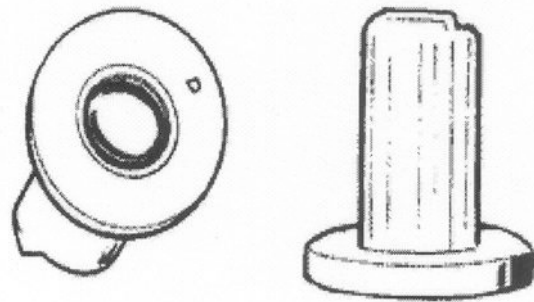

### Specific tooling

#### 020448y Piston pin circlip fitting tool

- With the gap in the position shown on the tool, fit the circlip into the tool by means of the drift.
- Rest the tool on the piston taking care that the side with the 90° bevel always faces upwards as shown in the figure.
- Fit the piston pin circlip using the tommy.

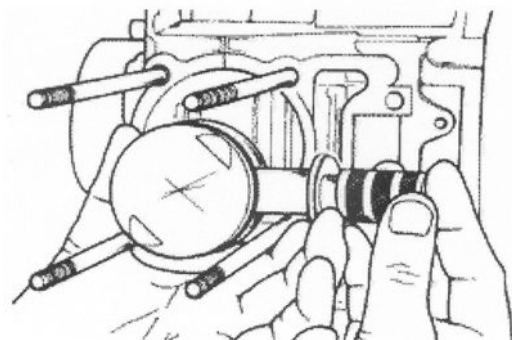

#### CAUTION

**USING A HAMMER TO FIT THE CIRCLIPS CAN DAMAGE THE CIRCLIP SEATS.**

## Refitting the piston rings

- Alternately insert the three piston rings into the cylinder, in the area where it retains its original diameter. Using the piston, insert the rings perpendicularly to the cylinder axis.
- Using a thickness gauge (see figure), measure the gaps of the piston rings.
- If any measurements are greater than prescribed, replace the piston rings.

**N.B.**

**BEFORE REPLACING THE PISTON RINGS ONLY, ENSURE THAT THE CLEARANCE BETWEEN THE PISTON RINGS AND THE PISTON RING GROOVES, AND BETWEEN THE PISTON AND THE CYLINDER, IS AS SPECIFIED. IN ANY CASE, NEW PISTON RINGS USED IN COMBINATION WITH A USED CYLINDER MAY HAVE DIFFERENT BEDDING CONDITIONS THAN THE STANDARD.**

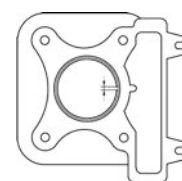

### SEAL RINGS

Name	Description	Dimensions	Initials	Quantity
1st ring		0,08 ÷ 0,20 mm		0,35 mm
2nd ring		0,05 ÷ 0,20 mm		0,30 mm
Scraper ring		0,20 ÷ 0,70 mm		0,80 mm

- Fit the scraper starting with the spring. Ensure that the scraper ends do not overlap. Fit the two piston rings so that their gaps and that of the scraper are never aligned.
- Fit the 2nd piston ring with the identification letter «T» facing the piston top.
- Fit the 1st piston ring with the «T» reference mark facing the piston top.
- Lubricate the parts with engine oil.

**N.B.**

**TO ENSURE OPTIMUM BEDDING, THE TWO PISTON RINGS HAVE CONICAL SECTIONS IN THE**



AREAS OF CONTACT WITH THE CYLINDER. FOR THIS REASON, IT IS IMPORTANT THAT THE RINGS SHOULD BE FITTED WITH THE "T" FACING UPWARDS. STAGGER THE PISTON RING GAPS BY 120 DEGREES AS SHOWN IN THE FIGURE.

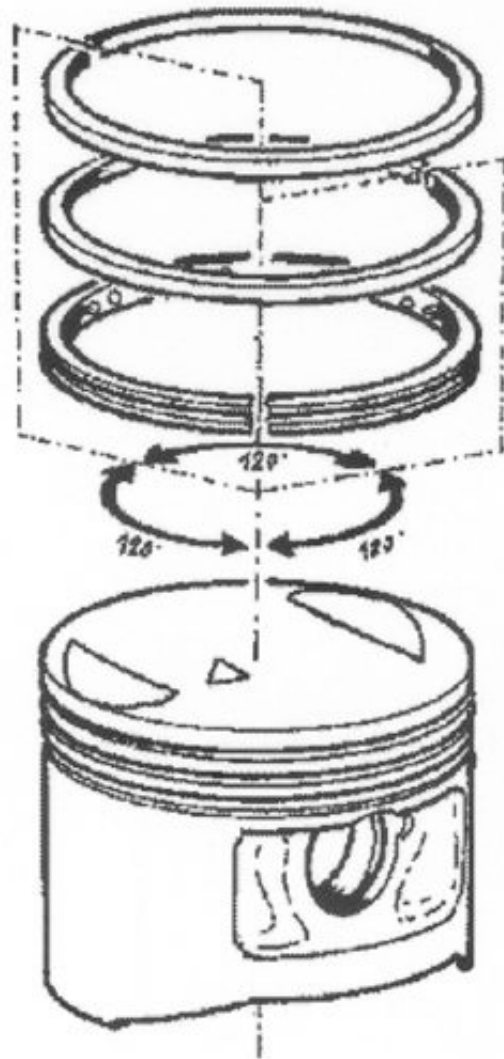

### Refitting the cylinder

- Insert the cylinder base gasket.
- Fit the cylinder as shown in the figure.
- It is possible to maintain the piston out of the crankcase plane using the special tool.

**N.B.**

**BEFORE FITTING THE CYLINDER, CAREFULLY BLOW THE LUBRICATION DUCT AND OIL THE CYLINDER BARREL.**

### Specific tooling

**020288y Fork for fitting piston to cylinder**

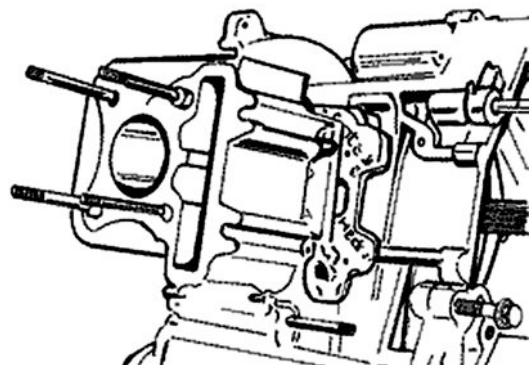

When replacing the four cylinder studs, on this engine, the head nuts must be tightened according to the procedure below.

This differs from what is specified on the vehicle's manual:

Head lock-nuts (cylinder stud replacement only)  $6\div 7 \text{ N}\cdot\text{m} + 135^\circ + 90^\circ$

The  $45^\circ$  reduction in rotation is necessary to prevent the excessive straining of the studs.

### Inspecting the cylinder head

- Using a trued bar, check that the cylinder head surface is not worn or distorted.
- Ensure that the camshaft and rocker arm pivot bearings show no signs of wear.
- Check that the cylinder head cover surface, the intake manifold and the exhaust manifold are not worn.

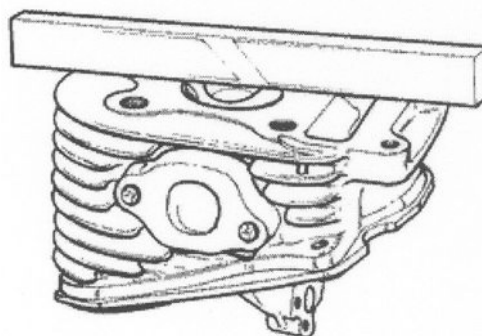

#### Characteristic

#### Maximum allowable runout: Inspecting the cylinder head

0,05 mm

#### CYLINDER HEAD

Specification	Desc./Quantity
Standard diameter (mm) A	$\varnothing 32,015 \div 32,025$
Standard diameter (mm) B	$\varnothing 16,0 \div 16,018$
Standard diameter (mm) C	$\varnothing 11,0 \div 11,018$

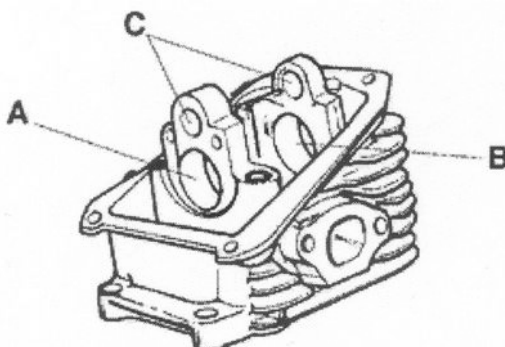

### Inspecting the timing system components

- Check that the guide shoe and the tensioner shoe are not worn out.
- Ensure that the camshaft drive pulley, the chain assembly and the pinion are not worn.
- Replace any worn components. If the chain, pinion or pulley are worn, replace the whole assembly.

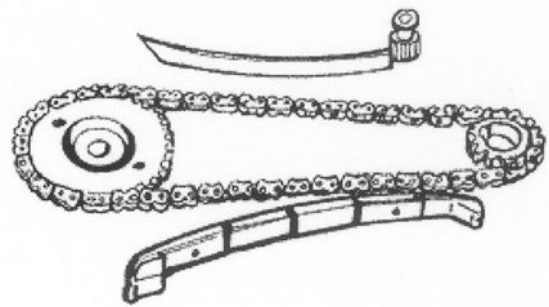

- Remove the central screw and the tensioner spring. Check that the one-way mechanism is not worn.
- Check the condition of the tensioner spring.
- If any worn components are found, replace the whole assembly.

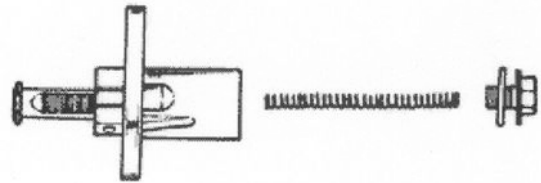

### Inspecting the valve sealings

- Measure the width of the sealing surface on the valve seats.



#### Characteristic

#### Sealing surface width Intake

1,5 mm

#### Sealing surface width Exhaust

1,6 mm

- Insert the valves into the cylinder head.
- Alternately test the intake and exhaust valves.
- The test is carried out by filling the manifold with petrol and checking that no petrol oozes through the valves when these are pressed with one finger.

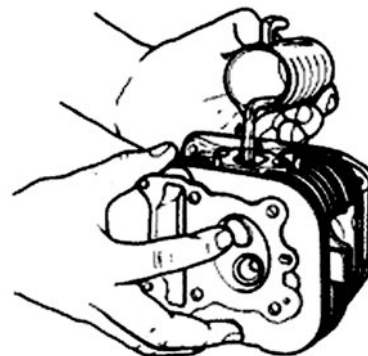

### Inspecting the valve housings

- Remove any carbon formation from the valve guides.
- Measure the inside diameter of each valve guide.
- Take the measurement at three different heights in the rocker arm push direction.

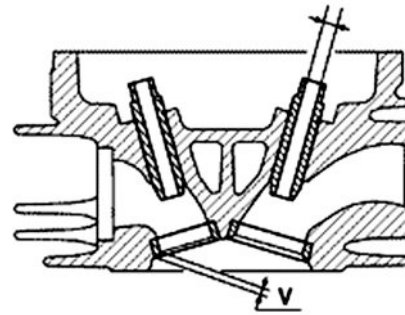

### Characteristic

#### Exhaust guide: Standard diameter

5 +0 +0,012 mm

#### Intake guide: Wear limit

5,022 mm

#### Intake guide: Standard diameter:

5 +0 +0,012 mm

#### Exhaust guide: Wear limit

5,022 mm

- If the width of the impression on the valve seat or the diameter of the valve guide exceed the prescribed limits, replace the cylinder head.

Measure the width of the impression on valve seat "V",

### Characteristic

#### The wear limit being

Max. 1,6 mm.

## Inspecting the valves

- Measure the diameter of the valve stem at the three positions shown in the figure.
- Calculate the clearance between the valve and the valve guide.

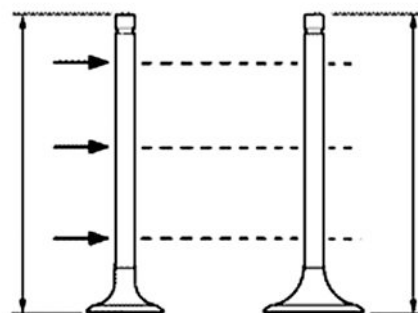

### Characteristic

#### Minimum allowable diameter: Intake

4,970 mm

#### Minimum allowable diameter: Exhaust

4,960 mm

### Fitting clearance

**Standard clearance: Intake**  $0,015 \div 0,042$  mm  
**Standard clearance: Exhaust**  $0,025 \div 0,052$  mm

- Check that the mating surface with the adjuster articulated terminal is not worn.
- Should the valve sealing area be greater than the prescribed limit, or if any bending or gaps are noted, replace the valve.

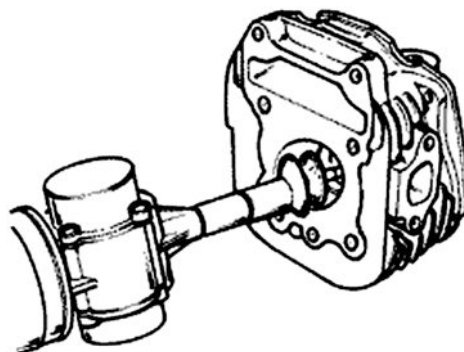

### Characteristic

**Valve standard length: Intake**

70,1 mm

**Valve standard length: Exhaust**

69,2 mm

### Fitting clearance

**Maximum allowable clearance: Intake** 0,052 mm  
**Maximum allowable clearance: Exhaust** 0,062 mm

- If no anomalies are found during the above checks, the same valves can be reused. For best sealing results, it is advisable to grind the valves. Grind the valves gently with a fine-grained lapping compound. During the grinding, keep the cylinder head in a horizontal position. This will prevent the lapping compound residues from penetrating between the valve stem and the guide.

### CAUTION

**TO AVOID SCORING THE MATING SURFACE, DO NOT KEEP ROTATING THE VALVE WHEN NO LAPPING COMPOUND IS LEFT. CAREFULLY WASH THE CYLINDER HEAD AND THE VALVES WITH A SUITABLE PRODUCT FOR THE TYPE OF LAPPING COMPOUND BEING USED.**

## Inspecting the springs and half-cones

- Check that the upper spring caps and the cotter halves show no signs of abnormal wear.

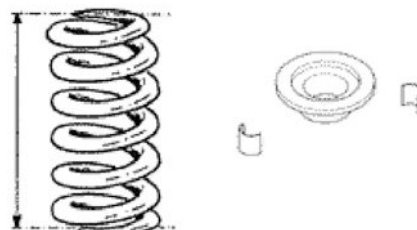

## Refitting the valves

- Lubricate the valve guides with graphitized oil.
- Position the valve spring lower caps on the cylinder head.
- Using the specific drift, alternately insert the two seal rings.

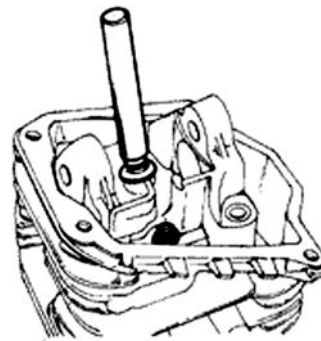

**Specific tooling**

**020306Y Valve sealing ring drift**

- Fit the valves, the springs and the upper caps.
- Using the specific tool, compress the springs and insert the cotter halves into their seats.

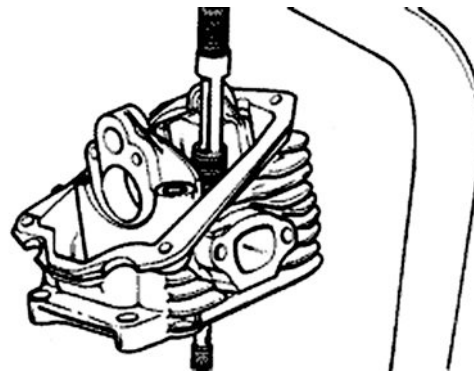

**Inspecting the cam shaft**

- Ensure that the camshaft bearings are not abnormally worn.

**Characteristic**

**Standard diameter - Bearing A:**

Ø 12 +0,002 +0,010 mm

**Standard diameter - Bearing B:**

Ø 16 -0,015 -0,023mm

**Minimum allowable diameter - Bearing A:**

Ø 11,98 mm

**Minimum allowable diameter - Bearing B:**

Ø 15,96 mm

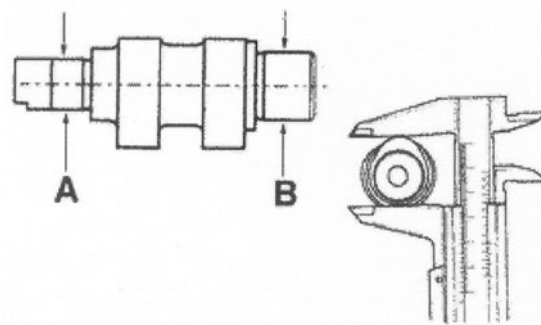

- If any measurements or values are not as specified, proceed to replace the defective parts.

**N.B.**

**A BALL BEARING IS FITTED ON BEARING «A»;  
CONSEQUENTLY, BEARING «B» IS MORE IM-**

**PORTANT BECAUSE IT WORKS DIRECTLY ON THE ALUMINIUM OF THE CYLINDER HEAD.**

### Characteristic

**Standard height - Intake:**

25,935 mm

**Standard height - Exhaust:**

25,935 mm

### Fitting clearance

**Maximum allowable axial play:** 0,5 mm

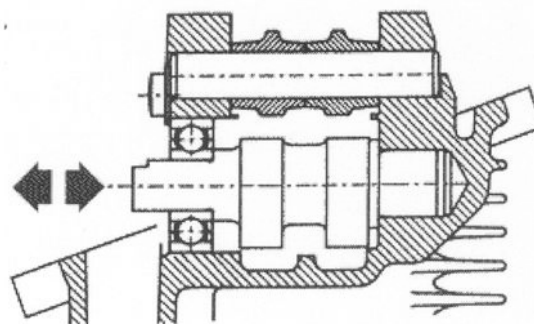

- Ensure that the rocker arm pivot is not worn or scored.
- Measure diameter «A».
- Measure the inside diameter of each rocker arm «B».
- Check that the cam contact shoe and the adjuster articulated cap are not worn.
- Replace any damaged parts.

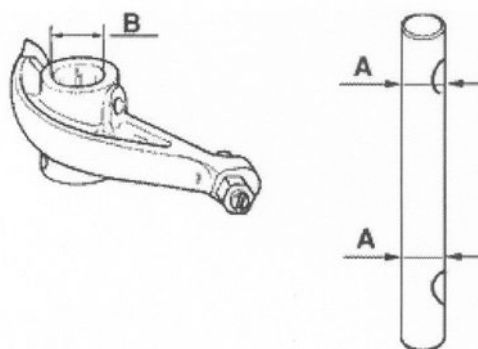

### Characteristic

**Minimum allowable diameter:**

Ø 10,970 mm

**Maximum allowable diameter:**

Ø 11,030 mm

## Refitting the head and timing system components

- Rest the cylinder head steadily on a worktable.
- Screw on the camshaft fitting tool to its abutting end on the bearing inner race.
- Using a mallet, drive the camshaft complete with the bearing all the way into its seat.
- Remove the tool.
- Fit the cylinder head gasket after carefully cleaning the mating surfaces.
- Insert the cylinder holding-down studs into the

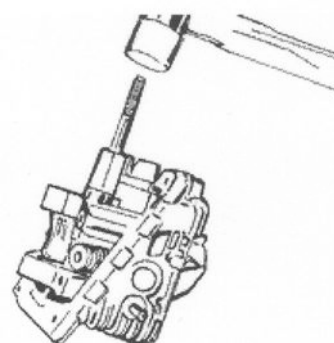

cylinder head and tighten the four locknuts with a torque

### Specific tooling

020450y Camshaft fitting/removing tool

### Locking torques (N\*m)

Head-cylinder stud nut:  $6 \div 7$  +135° +90° N·m for first fitting,  $6 \div 7$  90° +90° N·m for refitting/locking

- Loosen the rocker arm adjusters.
- Fit the pivot and the intake and exhaust rocker arms.
- Lubricate the two rocker arms through the holes.

**N.B.**

**REPLACE THE CAMSHAFT BEARING WITH A NEW ONE WHENEVER IT IS REMOVED.**

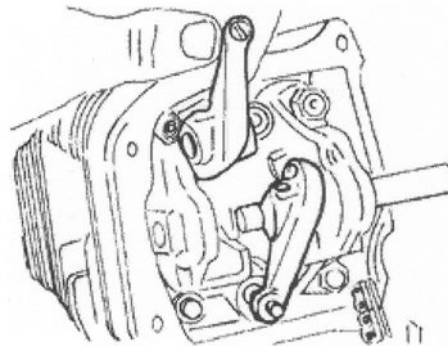

- Tighten the pivot and camshaft check screw complete with the washer shown in the figure.

### Locking torques (N\*m)

Rocker-arm shaft and camshaft bearing screw:  $3 \div 4$  Nm

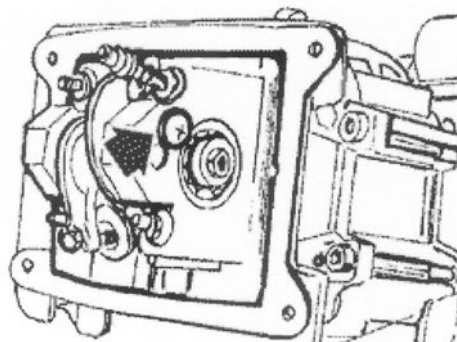

- To complete the fastening of the cylinder head, tighten the four cylinder head nuts in two phases in a crosswise pattern to a torque of 6 - 7 N·m. Continue tightening the nuts by giving them two 90-degree turns, following in a crosswise pattern.
- Complete the fastening of the cylinder head to the crankcase by tightening the two side screws.

**N.B.**

**WHENEVER THE CRANKCASE OR THE CYLINDER HOLDING-DOWN STUDS ARE REPLACED, PERFORM THE INITIAL TIGHTENING WITH A TORQUE**

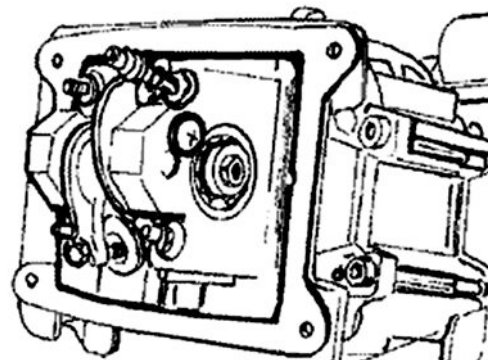



---

OF 6 - 7 N·M AND THEN CONTINUE THE TIGHTENING BY GIVING THE NUTS THREE 90-DEGREE TURNS IN THREE PHASES, FOLLOWING A CROSSWISE PATTERN.

### Locking torques (N\*m)

Head-cylinder stud nut:  $6 \div 7 +135^\circ +90^\circ$  N·m for first fitting,  $6 \div 7 90^\circ +90^\circ$  N·m for refitting/  
locking Tightening torque  $8 \div 10$  Nm

---

## Refitting the timing chain

- Insert the timing chain shoes into their respective housings and fit the screw and the spacer as shown in the figure.
- Tighten with the prescribed torque and check the movement of the tensioner shoe.
- Fit the timing chain pinion to the crankshaft with the bevel facing the insertion side (towards the crankshaft bearing).
- Fit the timing chain on the crankshaft.

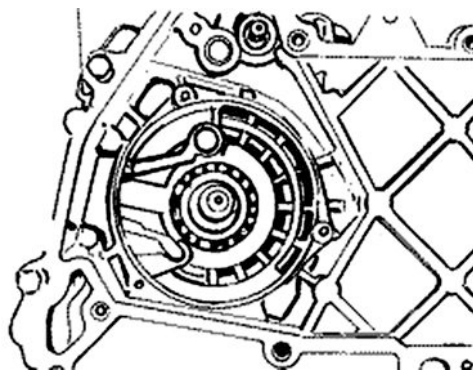

### Locking torques (N\*m)

Chain-tensioning pad screw:  $5 \div 7$  Nm

- Fit the spacer on the camshaft.
- Position the piston at the top dead centre by referring to the marks between flywheel and crankcase.
- While keeping the piston in position, fit the chain on the camshaft drive pulley, while maintaining the reference notch aligned with the mark on the cylinder head.
- Fit the pulley on the camshaft.
- Fit the Belleville washer so that its outer rim is in contact with the pulley.
- Turn in the screw until it makes contact, without tightening it fully.

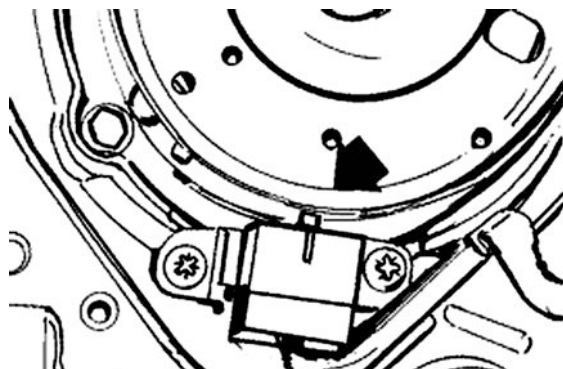

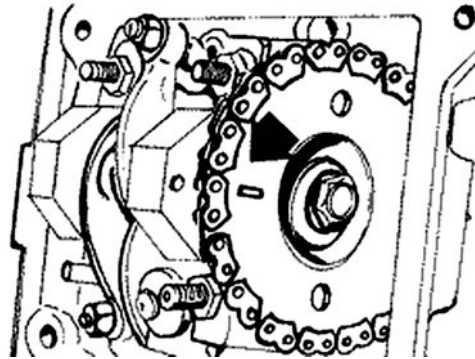

- Slightly press the tensioner shoe to verify the valve gear timing.
- Using the specific tool, lock the camshaft ring gear and then tighten the screw.
- Adjust the play of the valves
- Replace the O-ring on the tappet cover.
- Fit the tappet cover and fasten it using the four fixing screws shown in the figure.

### Specific tooling

**020565Y Compass flywheel stop spanner**

### Locking torques (N\*m)

**Camshaft pulley screw: 12 ÷ 14 Nm Head cover screw: 8 ÷ 10 Nm**

- Put the idler in the standby position.
- Fit the idler on the cylinder using a new seal, tighten the 2 screws to the prescribed torque.
- Insert the spring with the central screw and tighten it to the prescribed torque.
- Fit the sparkplug.

### Characteristic

#### Reccomended spark plug

NGK CR 9EB - CHAMPION RG 4HC

#### Electric characteristic

##### Spark gap

0,7 ÷ 0,8 mm

### Locking torques (N\*m)

**Timing chain tensioner screw: 8 ÷ 10 Nm Timing chain tensioner central screw: 5 ÷ 6 Nm**

**Ignition spark plung 10 ÷ 15 N.m**

---

## Refitting the rocker-arms cover

---

- Perform the removing procedure in reverse or-

der and then tighten the four screws with the prescribed torque.

**N.B.**

**FIT A NEW O-RING ON THE TAPPET COVER.**

**Locking torques (N\*m)**

**Chain tensioner thrust screw  $8 \div 10$  N.m**

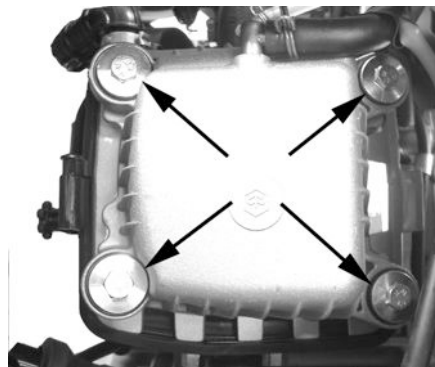

## Refitting the intake manifold

- Fit the casing seal on the head
- Fit the 2 casings.
- Fit the suction manifold and tighten the 2 screws to the prescribed torque
- Fit the carburetor on the suction manifold and tighten the band.
- Fit the secondary air hose and secure it with the band.

**N.B.**

**ADJUST THE ORIENTATION OF THE CARBURETOR BY MEANS OF THE PROJECTION ON THE MANIFOLD.**

**Locking torques (N\*m)**

**Tightening torque  $7 \div 9$  N.m**

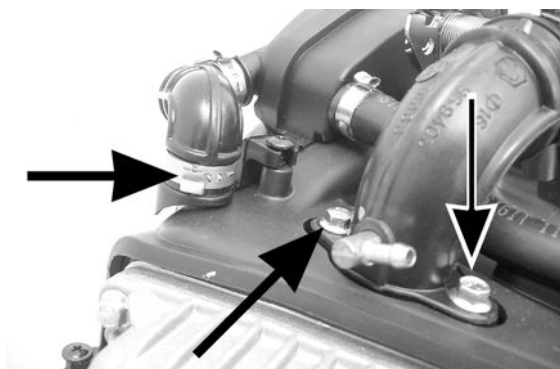

## Crankcase - crankshaft

- First remove the following units:

Drive pulley

Driven pulley

Final reducing gear

Oil pump

Flywheel with stator

Cylinder-piston-head unit

Starter motor with wire unit.

**See also**

[Removing the driving pulley](#)  
[Removing the driven pulley](#)  
[Removal](#)  
[Removing the stator](#)  
[Removing the cylinder - piston assy.](#)  
[Removing the starter motor](#)

## Splitting the crankcase halves

- Remove the ten crankcase coupling screws.
- Separate the crankcase while keeping the crankshaft fitted to the crankcase half on the transmission side.
- Remove the crankshaft.

### CAUTION

**THE CRANKSHAFT MAY FALL IF THIS PRECAUTION IS NOT TAKEN.**

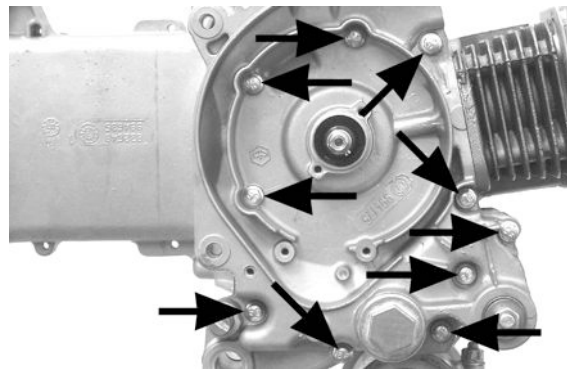

- Remove the oil seal on the flywheel side.

### CAUTION

**A CENTRIFUGAL OIL FILTER IS FITTED IN THE FLYWHEEL-SIDE SHAFT. TO PREVENT IMPURITIES FROM COMING OUT, AVOID WASHING WITH ANY SOLVENT OR BLOW WITH COMPRESSED AIR. THE CENTRIFUGAL OIL FILTER REQUIRES NO MAINTENANCE AND ITS SERVICE LIFE IS EQUIVALENT TO THAT OF THE ENGINE.**

- Check the connecting rod axial play.

### Fitting clearance

**Standard play 0,15 ÷ 0,30 mm Maximum play 0,5 mm**

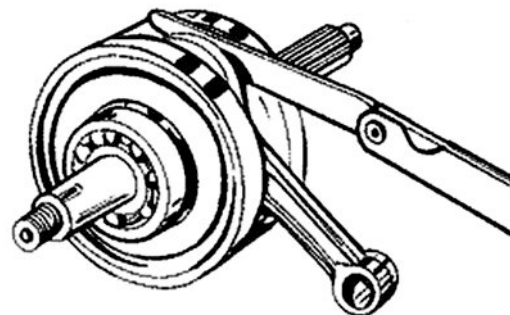

- While holding the crankshaft manually, check the connecting rod radial play. Measure the play with a comparator placed on the tip of the connecting rod small end while moving the connecting rod vertically as shown in the figure.

**Fitting clearance**

**Standard play**  $0,006 \div 0,018$  mm **Maximum play** 0,25 mm

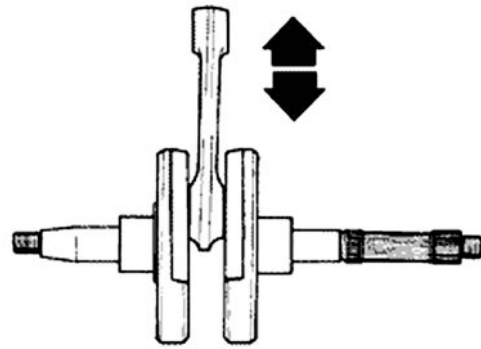

- Check that the surface of both crankshaft halves is not scored. Using a calliper, measure the width of the crankshaft as shown in the figure.

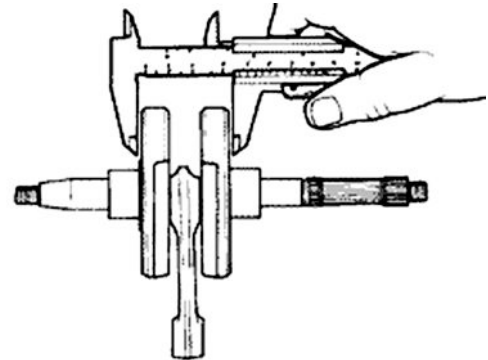
**Characteristic****Standard width**

45 mm

**Removing the crankshaft bearings**

- Using the specific tool, remove the bearing from the crankshaft on the flywheel side.

**Specific tooling**

**004499y Bearing extractor**

**004499y001 Bearing extractor fitted with parts**

**004499y002 Bearing extractor fitted with parts**

**004499y006 Bearing extractor fitted with parts**

**004499y034 Bearing extractor fitted with parts**

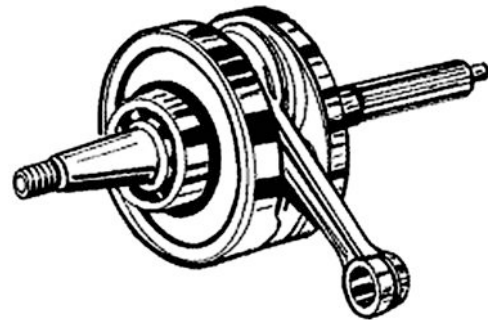
**Refitting the crankshaft bearings**

- Heat a new crankshaft bearing in oil at 120° C.  
 - Position the crankshaft on the stand and fit the bearing; if necessary use a suitable length of tube.

**N.B.**

**ON REASSEMBLY, ALWAYS USE A NEW BEARING.**

**WARNING**

**- A CENTRIFUGAL OIL FILTER IS FITTED IN THE FLYWHEEL-SIDE SHAFT. TO PREVENT IMPURITIES FROM COMING OUT, AVOID WASHING WITH ANY SOLVENT OR BLOW WITH COMPRESSED AIR.**

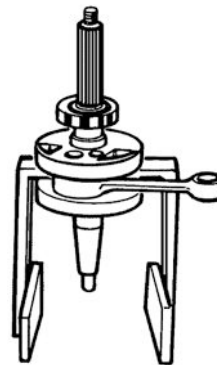
**Specific tooling**

**020265y Bearing fitting stand**

**008119y009 Tube (shaft fitting tool)**

- Rest the crankcase on a flat surface with the crankshaft axis in an upright position.
- Using the thermal gun and its stand, heat the crankcase to approximately 120° C.
- Prepare the drift with the guide and adaptor; fit the bearing on the drift with a little grease (to prevent it from falling).
- Insert the bearing into the crankcase; if necessary use the hammer very carefully to avoid damaging the stop on the crankcase.

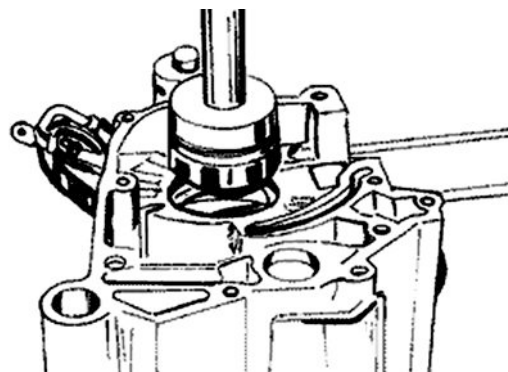
**Specific tooling**

**020359Y 42 x 47 mm hub bearing fitting adaptor**

**020364Y 25 mm guide**

**020376Y Handle for punches**

**020360Y 52 x 55 mm adaptor**

**Inspecting the crankshaft alignment**

- Place the crankshaft on the stand and measure the runout at the four points shown in the figure.

**N.B.**

IF THE RUNOUT MEASUREMENTS SLIGHTLY EXCEED THE SPECIFIED LIMITS, TRY TO STRAIGHTEN THE CRANKSHAFT BY INSERTING A WOODEN WEDGE BETWEEN THE SHAFTS OR, IF NECESSARY, BY CLAMPING THEM IN A VICE. IF, DESPITE THE STRAIGHTENING, THE VALUES ARE NOT AS SPECIFIED, PROCEED TO REPLACE THE CRANKSHAFT.

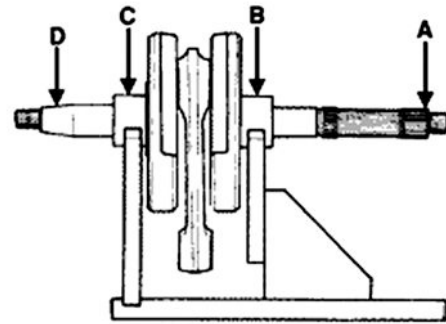
**Characteristic****Maximum allowable runout - A**

0,15 mm

**Maximum allowable runout- B**

0,02 mm

**Maximum allowable runout- C**

0,02 mm

**Maximum allowable runout - D**

0,10 mm

- Check the condition of the crankshaft cone, the tab seat, the oil seal bearing, the knurled pin and the threaded tangs.

- If any anomalies are found, replace the crankshaft.

**Specific tooling**

**020074Y Crankshaft aligning tool**

**Refitting the crankcase halves**

- Take care to correctly position the two dowel bolts, preferably on the flywheel-side crankcase half.

- Fit the crankcase to the transmission-side crankcase half.

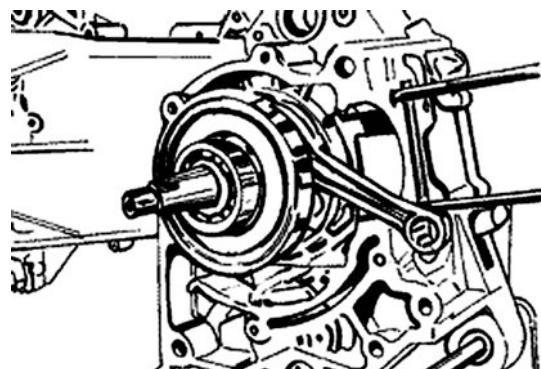

- Apply grease for surfaces over the transmission-side crankcase half after carefully degreasing the

mating surfaces.

- Fit the flywheel-side crankcase.
- Fit the ten screws and tighten with the prescribed torque.

**N.B.**

**WHILE ASSEMBLING THE CRANKCASE AND THE CRANKSHAFT, TAKE CARE NOT TO DAMAGE THE THREADED TANGS OF THE CRANKSHAFT.**

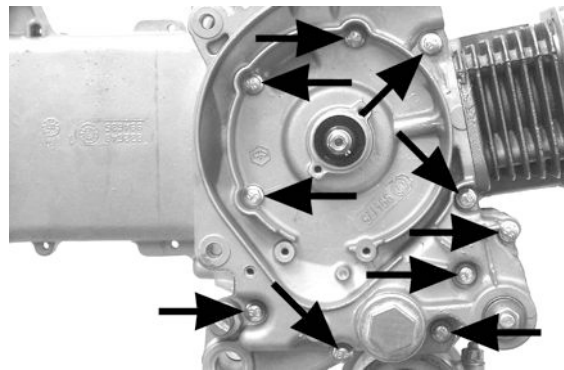

### Recommended products

**Loctite 510 Packing fluid**

Packing

### Locking torques (N\*m)

**Half-crankcase joining screws: 8 ÷ 10 Nm**

- Fit a new O-ring on the oil gauze strainer and on the filler cap and then lubricate them.
- Fit the strainer on the engine and tighten the cap with the prescribed torque.

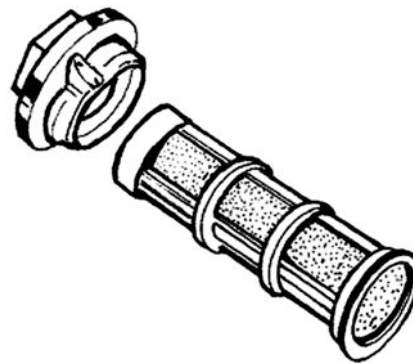

### Locking torques (N\*m)

**Engine oil pre-filter cap: 25 ÷ 28 Nm**

## Lubrication

### Crankshaft oil seals

### Removal

- Check that the chain thrust shoe is not worn.
- If the shoe is worn, replace it or fit it the other way round to make it work on the other side.
- Any operation involving the chain cover oil seal must be carried out after resting the oil pump chain cover plate side on a workbench.
- Remove the oil seal using a length of tube

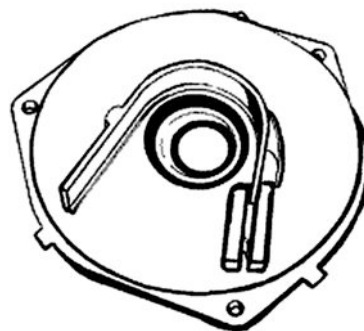



measuring approximately 30 mm in diameter  
(max. Ø 32 mm).

- Extract the flywheel-side oil seal from the crankcase taking care not to damage or score the crankcase.

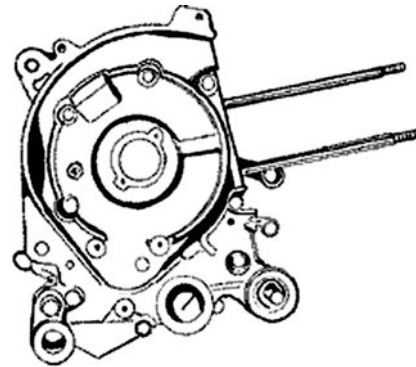

## Refitting

- Pour engine oil over the oil seal and its seat in the crankcase.
- Operating from the outside with the specific drift, push the oil seal fully home into its seat in the crankcase.

**N.B.**

**FAILURE TO USE THE SPECIFIC TOOL MAY RESULT IN THE OIL SEAL BEING DRIVEN TO AN UNSUITABLE DEPTH, WHICH WOULD CAUSE THE OIL SEAL TO MALFUNCTION.**

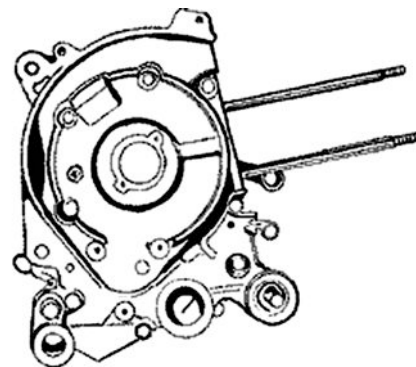

- Using the tools listed below, fit a new oil seal so it is flush with the outer rim.
- Fit a new O-ring and grease it.
- Position the cover on the crankcase, insert the three screws and fit the cover in place
- Tighten the three screws with the prescribed torque.

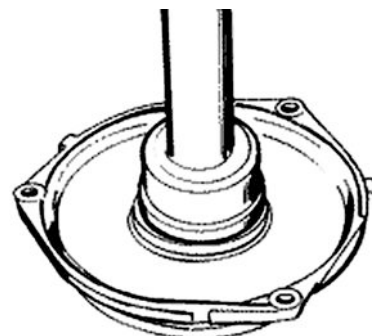

## Specific tooling

**020376Y Handle for punches**

**020358y 37 x40 adaptor**

**Locking torques (N\*m)**

Tightening torque 4 ÷ 5 Nm

**Oil pump****Removal**

- Remove the chain compartment cover with the 3 screws shown in the figure.
- Extract the cover using the specific handles attached to the cover with a pair of pliers

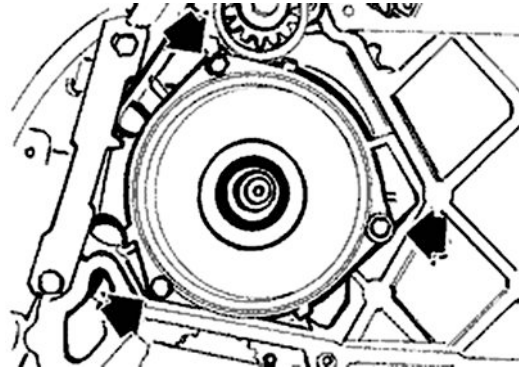

- Remove the cover from the pump drive ring gear after removing the two fastenings shown in the figure.
- Prevent the oil pump drive gear from rotating by inserting a screwdriver into one of its holes.

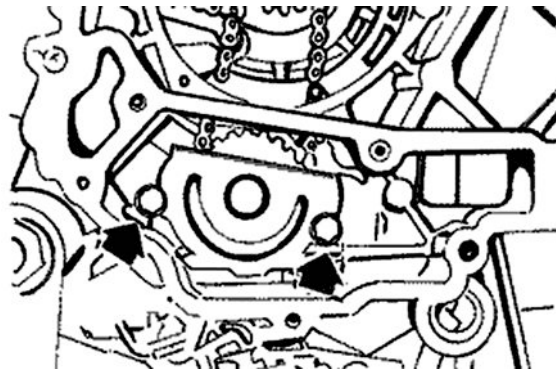

- Remove the central screw with Belleville washer
- Remove the chain with toothed crown.
- Remove the engine shaft distribution control pinion
- Remove the oil pump with the 2 screws shown in the figure.
- Remove the seal.

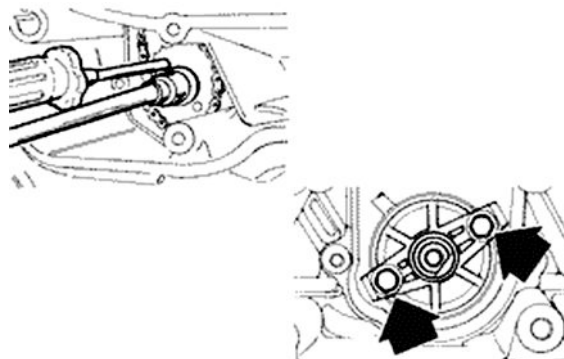
**CAUTION**

**THE CHAIN SHOULD BE MARKED TO ENSURE THAT THE ORIGINAL DIRECTION OF ROTATION IS MAINTAINED.**

## Inspection

- Remove the two screws and the oil pump cover.
- Remove the inner rotor circlip.
- Remove the rotors and carefully clean them with a degreasing solvent and compressed air.
- Reassemble the rotors with the pump body, leaving the two reference marks in view. Fit the circlip.



- Using a thickness gauge, measure the distance between the rotors (inner rotor - outer rotor) at the position shown in the figure.

### Characteristic

#### Maximum allowable clearance

0,15 mm

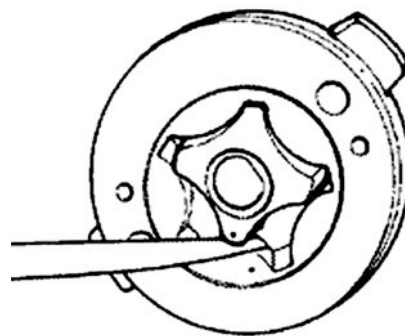

- Measure the distance between the outer rotor and the pump body (see figure).

### Characteristic

#### Maximum allowable clearance

0,20 mm

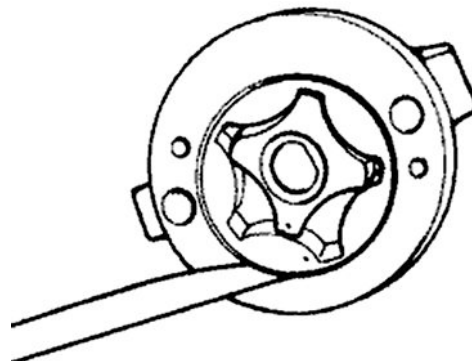

- Check the axial play of the rotors using a trued bar as shown in the figure.

**N.B.**

**ENSURE THAT THE TRUED BAR RESTS PROPERLY ON TWO POINTS OF THE PUMP BODY PLANE.**

### Characteristic

#### Maximum allowable clearance

0,09 mm

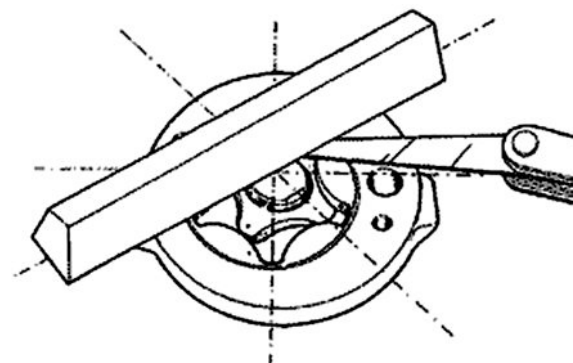

---

## Refitting

---

- Ensure that the pump shaft and body are not worn.
- Check that the pump cover is not worn or scored.
- If any measurement is not as specified, or if any part is scored, replace the part or the assembly.
- Fit the cover on the pump taking care to align the holes (two on the cover and two on the pump body) for the fastening of the oil pump on crankcase.
- Fit the oil pump to the crankcase and tighten the two fixing screws with the prescribed torque.
- Fit the pulley on the pump, the central screw with the prescribed torque and the belleville washer.
- Ensure that the pulley rotates smoothly, with no jerks or friction.

**N.B.**

**FIT THE BELLEVILLE WASHER SO THAT ITS OUTER (CURVED) RIM IS IN CONTACT WITH THE PULLEY.**

### Locking torques (N\*m)

**Central screw tightening torque 12 - 14 N·m**

**Cover screw tightening torque 0.7 - 0.9 N·m**

**Oil pump screw tightening torque 5 ÷ 6 Nm**



---

## Removing the oil sump

---

- Remove the oil filler cap, the transmission cover, the drive pulley assembly with the belt, and the pinion.
- Remove oil drain plug «A» shown in the figure and drain the oil from the sump.
- Remove the six screws shown in the figure.

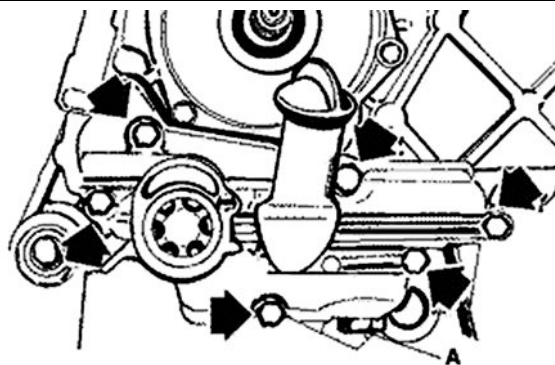

## Refitting the oil sump

- Clean and degrease the mating surfaces.
- Apply LOCTITE 510 over the sump surface and tighten the 6 fixing screws with the prescribed torque.
- Fit the drive pulley assembly, the belt, the pinion and the transmission cover.

### CAUTION

**FOR THE CHECKS RELATING TO THE LUBRICATION OF THE CONNECTING ROD ASSEMBLY, REFER TO THE CHAPTER "CRANKCASE AND CRANKSHAFT".**

### Locking torques (N\*m)

**Tightening torque 8 ÷ 10 Nm**

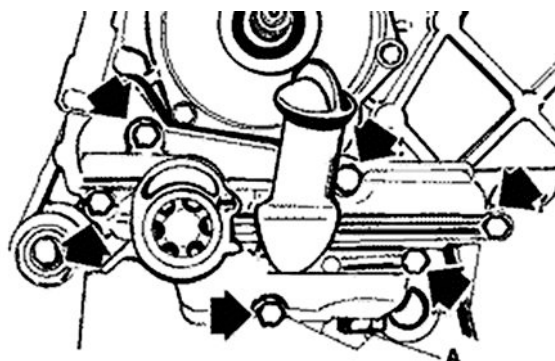

## Fuel supply

- Drain the fuel from the tank.
- Remove the fuel delivery pipe and the vacuum pipe.
- Release the clamp and remove the cock.
- Clean the tank and the cock filter with a suitable solvent.
- Refit the cock taking care to verify the presence of the O-ring.
- Turn the cock in the same direction as before the removal and then tighten the clamp.

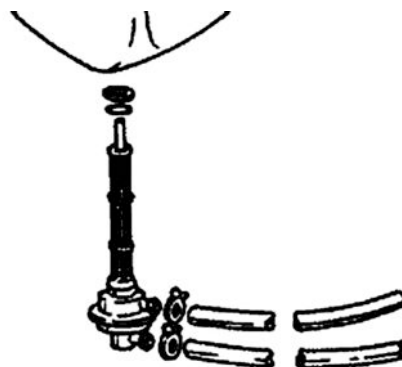

---

**N.B.**

**THE FILTER CAN BE SCREWED OFF THE COCK TO FACILITATE THE CLEANING.**

---

- Disconnect the fuel feed pipe and the vacuum pipe from the carburettor.
- Ensure that no fuel is leaking from the pipes.
- Close the fuel outlet.
- Using the MITYVAC pump, apply a 0.1 bar vacuum to the cock.
- Ensure that the vacuum does not change, and that no fuel is leaking.
- Reconnect the vacuum pipe to the manifold.
- Position the fuel pipe so that its outlet is on the same level as the cock.
- Make the engine turn by operating the starter motor for five seconds with the carburettor in the idle position.
- Gather the fuel in a graduated burette.

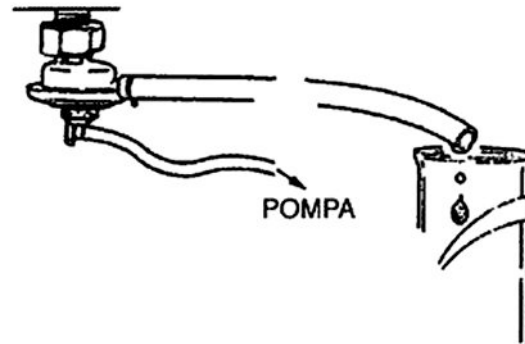
**N.B.**

**THE MEASUREMENT MAY BE ALTERED BY AN UNSUITABLE ENGINE SPEED OR BY INCORRECT POSITIONING OF THE PIPE. IN THAT CASE, A REDUCED FUEL DELIVERY IS GENERALLY OBTAINED. THE VACUUM HOLE ON THE MANIFOLD HAS AN INTENTIONALLY REDUCED CROSS-SECTIONAL AREA IN ORDER TO IMPROVE THE VACUUM PULSES AND ENSURE CONSTANT DELIVERY OF THE COCK.**

### Specific tooling

020329Y Pump MITYVAC

### Characteristic

#### Minimum delivery

20 cc

---

## Removing the carburettor

---

- To remove the carburettor from the engine, remove the two clamps fastening the carburettor to the intake manifold, and from the air inlet sleeve to the filter.
- Remove the fuel feed pipe.
- Detach the starting device connection.
- Detach the throttle cable complete with the sheath from the support plate.
- Remove the carburettor.

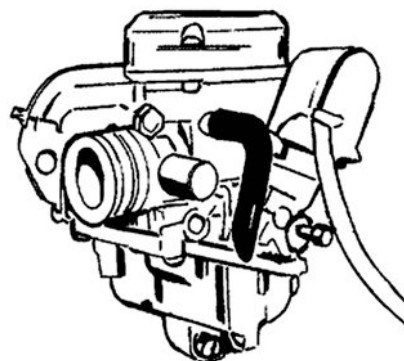

- Remove the protection, the bracket and the starting device after loosening the screw shown in the figure.

**CAUTION**

**THE CARBURETTOR HAS A RUBBER CUSHIONING PAD FITTED ON THE LOWER PROJECTION OF THE ACCELERATING PUMP BODY. MAKE SURE OF THE PRESENCE OF THE CUSHIONING PAD WHEN REFITTING THE CARBURETTOR ON THE ENGINE SO AS TO PREVENT THE PETROL IN THE FLOAT CHAMBER FROM BEING EMULSIFIED.**

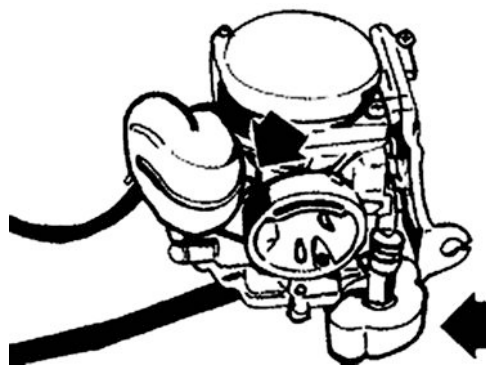

- Remove the two fixing screws shown in the figure, the vacuum chamber cover and the spring.
- Remove the vacuum valve complete with the membrane, the needle, the spring and the related plastic guide.

**WARNING**

**TAKE SPECIAL CARE WHEN REMOVING THE COVER AS THE SPRING MAY COME OFF ABRUPTLY.**

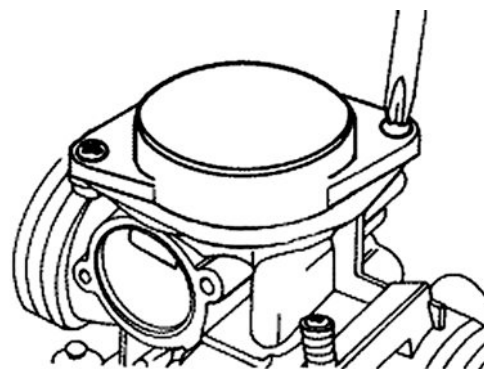

- Remove the three fixing screws and the float chamber with the related gasket.

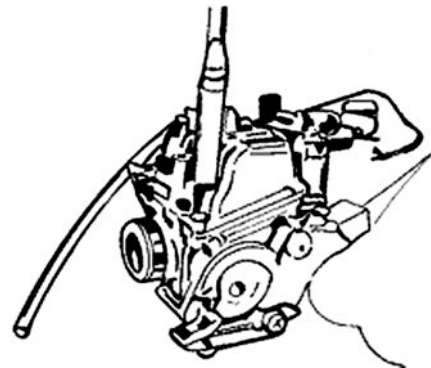

---

- Disassemble the float chamber components according to the following procedure.

- Loosen the two screws fixing the accelerating pump membrane cover.

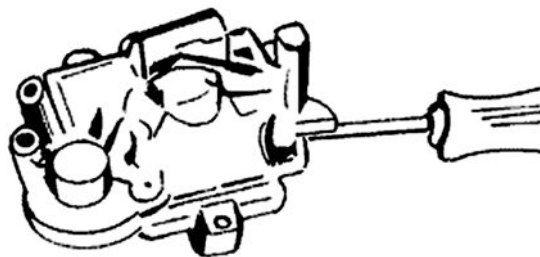

---

- Remove the cover paying attention to the spring below it, then remove the spring, the rubber protection and the related membrane complete with the pin and the duct O-ring.

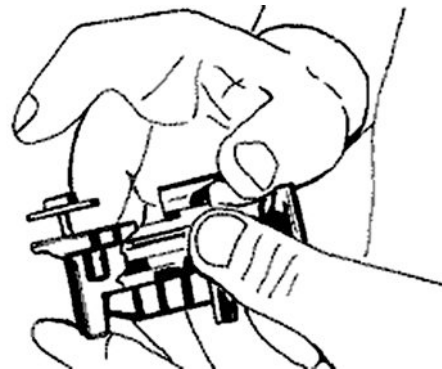

---

- Remove the accelerating pump jet complete with the ball spring.

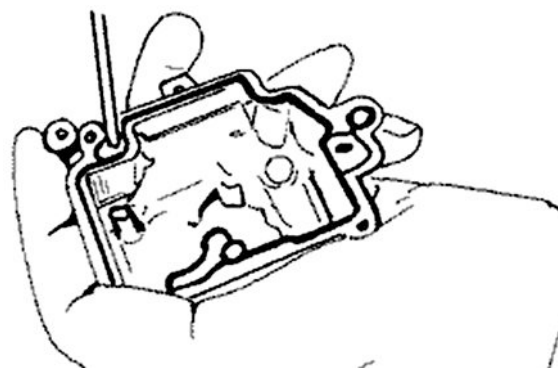

---

- Remove the screw fixing the float pin (see figure).

- Remove the float and the needle.





- Remove the main jet.
- Remove the diffuser.

- 
- Tilt the carburettor body and remove the atomizer.

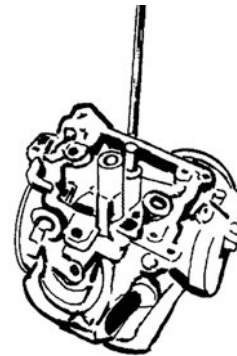
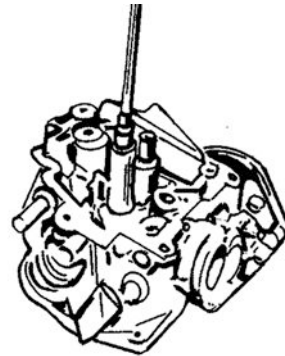

- 
- Remove the idling jet.

**N.B.**

**THIS OPERATION IS REQUIRED TO AVOID LOSING THE ATOMIZER WHEN CLEANING THE CARBUR-ETTOR BODY. SHOULD THE ATOMIZER BE JAMMED IN ITS SEAT, DO NOT REMOVE IT, OR IT MAY BE DAMAGED.**

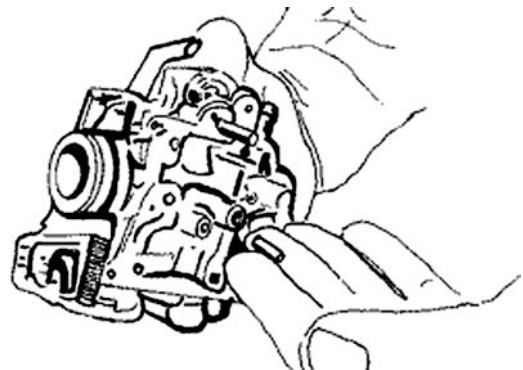

- 
- Remove the idle flow screw with the O-ring, the

---

washer and the spring.

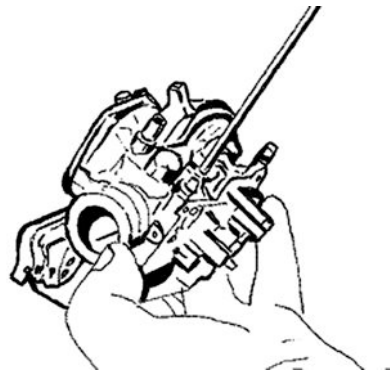
**CAUTION**

**DO NOT ATTEMPT TO REMOVE ANY OF THE COMPONENTS BEDDED IN THE CARBURETTOR (FUEL FEED DUCT, NEEDLE SEAT, STARTING JET, THE THROTTLE VALVE CONTROL SHAFT, ETC.). DO NOT REMOVE THE SCREWS CONNECTING THE THROTTLE VALVE TO THE CONTROL SHAFT. THE FIXING SCREWS ARE CAULKED AFTER THE FITTING, AND THEIR REMOVAL WOULD DAMAGE THE CONTROL SHAFT.**

---

## Refitting the carburettor

- Before refitting the carburettor, carefully clean the carburettor body with a degreasing solvent and compressed air.
- Pay special attention to the fuel intake duct and the needle seat.

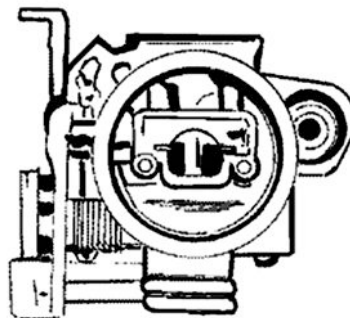

- When working on the idle circuit, take special care in properly cleaning the following parts: air calibrator, outlet section controlled by the flow screw, progression holes next to the throttle valve.

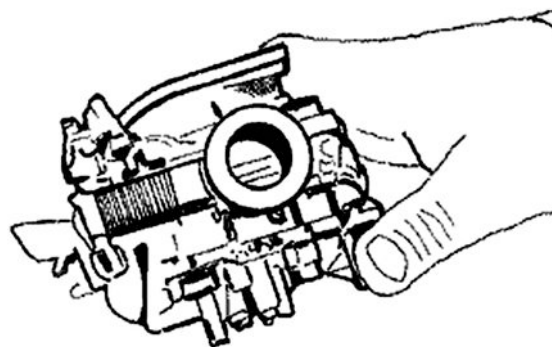

- As for the starting circuit, pay attention to the duct connecting with the jet. Special care is needed because the jet support contains other calibrators which are not accessible from the out-

side.

- Carefully blow the acceleration jet.
- The cross-sectional area of its outlet is very small and faces the throttle valve.

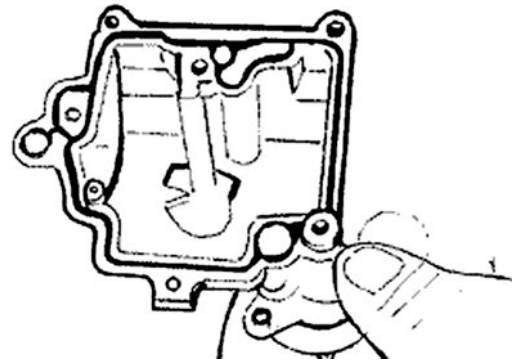

- Ensure that the idle circuit working duct closing ball is present on the carburettor body.
- Check that the mating surfaces with the float chamber and the membrane are not dented.
- Check that the vacuum valve housing duct is not scored.
- Check that the throttle valve and the spindle are not abnormally worn.
- Check that the needle seat is not abnormally worn.
- If any anomalies are found, proceed to replace the carburettor.

**N.B.**

**TO AVOID DAMAGE, DO NOT INSERT METAL OBJECTS IN THE CALIBRATED SECTIONS.**

- Carefully wash and blow the idling jet, and then refit it.

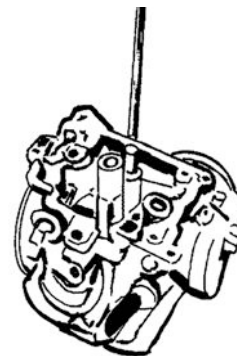

- Carefully wash and blow the main circuit components, the atomizer, the diffuser and the jet.
- Insert the atomizer in the carburettor body with the larger cylindrical part facing the diffuser.
- Fit the diffuser.
- Fit the main jet.

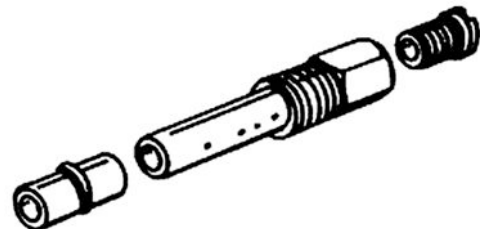

- Ensure that the sealing surface, the dampened pin and the return spring of the conical needle are not worn.

- If any worn parts are found, replace the needle.
- Check that the float pin housing and needle contact plate are not worn, and that no fuel leakage is present.
- If any anomalies are found, replace the float.
- Fit the float complete with the pin and the needle into its housing and lock it with the fastening screw.

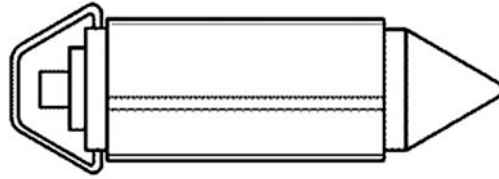

**N.B.**

**TAKE CARE TO PROPERLY FIT THE RETURN SPRING TO THE FLOAT PLATE.**

- Insert the ball into the accelerating pump.
- Insert the spring.
- Insert the accelerating pump jet.

**WARNING**

**PAY SPECIAL ATTENTION DURING REASSEMBLY AS THE COMPONENTS ARE VERY SMALL.**

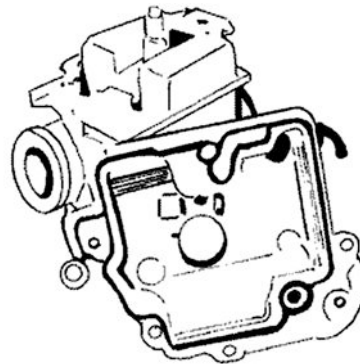

- Check the condition of the membrane and then refit the remaining pump components in the following order:
  - Insert the O-ring into the duct.
  - Insert the membrane complete with the pin and the related spring.

**N.B.**

**REPLACE MEMBRANE IF IT IS CRACKED, BROKEN, OR IF IT HAS HARDENED EXCESSIVELY.**

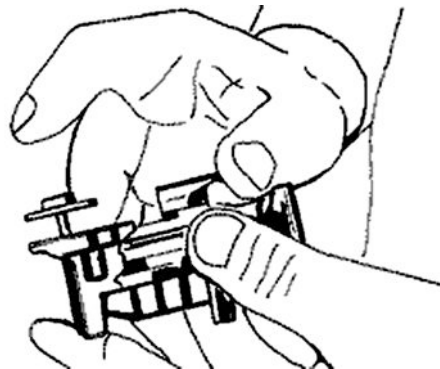

- Fit the accelerating pump membrane cover and tighten the two fixing screws taking care to properly insert the spring underneath.
- Fit the pin rubber bellows in the upper part of the accelerating pump.

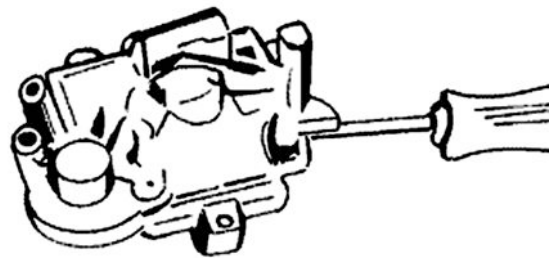

### Level check

- Tilt the carburettor so that the fuel inlet needle valve is closed but the float does not weigh heavily on it.
- Check the parallelism between the membrane closing surface and the float central line as shown in the figure.

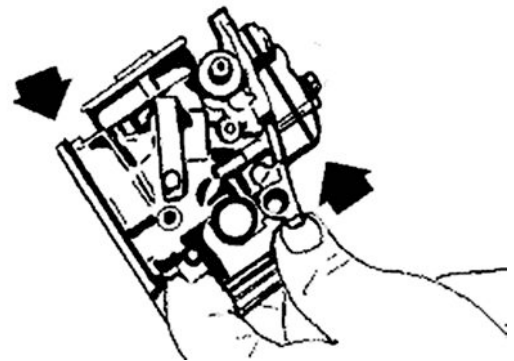

- Carefully blow the float chamber and then fasten it on the carburettor body with the related gasket by means of the three fixing screws.

**N.B.**

**WHEN REFITTING, ALWAYS USE NEW RINGS AND GASKETS.**

**WARNING**

**THE SCREW IN THE LOWER PART OF THE FLOAT CHAMBER IS ONLY A BLEEDER AND ONLY NEEDS CLEANING.**

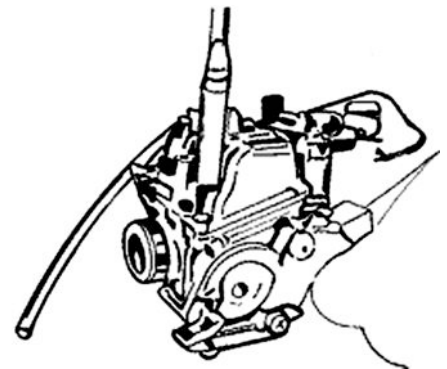

- Insert the membrane into the throttle valve.
- Insert the conical needle complete with the plastic support and the thrust spring into the throttle valve.

**N.B.**

**POSITION THE SPRING PLASTIC SUPPORT WITH THE TEETH FACING THE INSIDE OF THE MEM-**

---

**BRANE SO AS TO CREATE THE LOWER HOUSING FOR THE THROTTLE VALVE SPRING.**

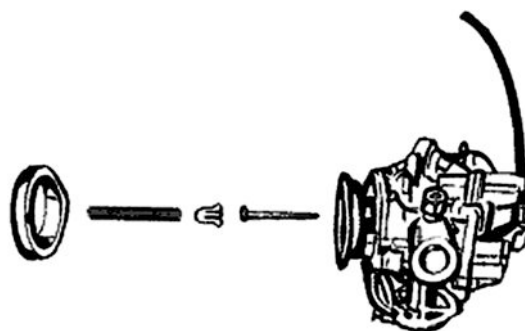

---

- Fasten the vacuum chamber cover by applying the two fixing screws. Pay special attention to the spring.

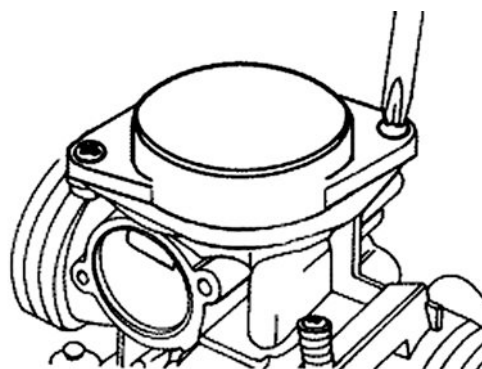

---

### Inspecting the automatic choke device

- Ensure the automatic choke piston is not scratched or oxidised.
- Ensure the piston is free to slide within its housing.
- Check the piston O-ring is not deformed.
- The choke must be engaged as a function of the ambient temperature.
- Measure the piston projection, as shown in the figure, and check the corresponding value.
- Ensure the choke is settled to the ambient temperature.

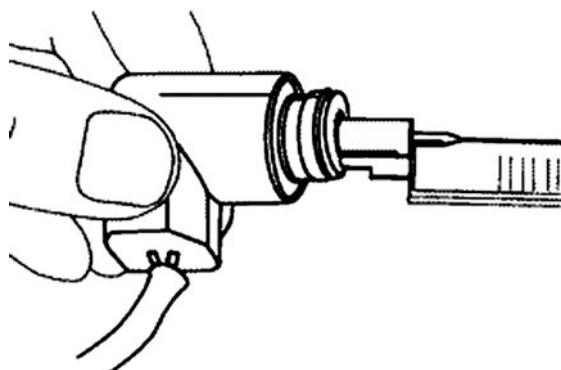

#### **Characteristic**

#### **Projection value**

11,5 mm

#### **Temperature**

24° C

- The choke device must disengage progressively through electric heating.

- Check the choke resistance when this has settled to ambient temperature.

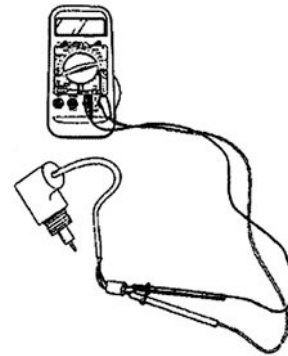

**Characteristic  
Temperature**

24° C

**Electric characteristic**

**Automatic choke resistance**

20 Ω ± 5 %

- Using a battery, apply power to the starting device and check that the piston reaches the maximum projection.

- The actual warming-up time depends on the ambient temperature.

- If any projection, resistance or time is not as specified, replace the starting device.

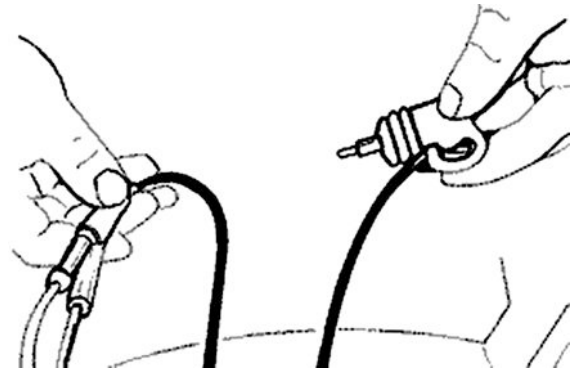

**Characteristic**

**Battery**

12V-9Ah

**Maximum projection**

15 mm

**Maximum time**

15 minutes

- Fasten the starting device, the support bracket and the protection by means of the screw shown in the figure.

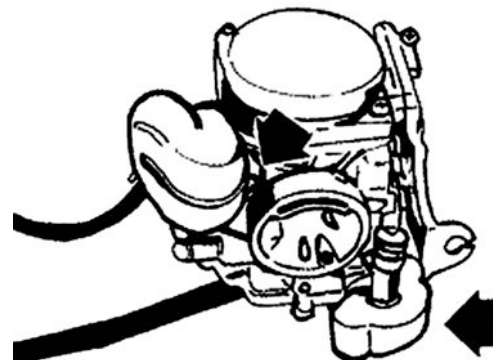

- Insert the float chamber aeration rubber pipe.
- Insert the O-ring, the washer, the spring and the idle flow screw into their housing.

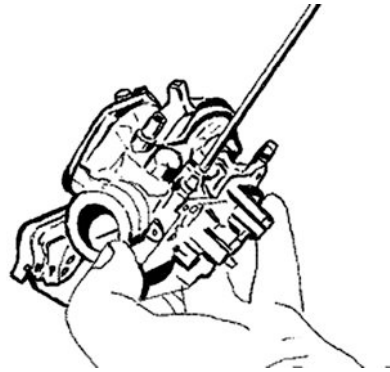

- Fit the carburettor on the engine, reconnect the throttle cable complete with the sheath to the support plate and the starting device electrical connection.
- Reconnect the fuel feed pipe and tighten the two clamps fixing the carburettor to the intake manifold and to the air intake sleeve on the filter.

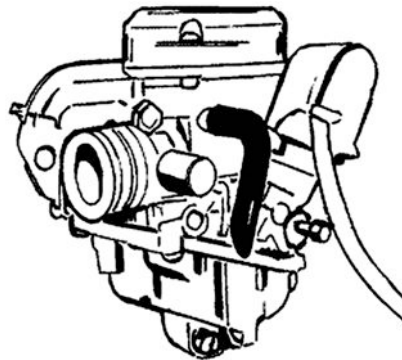

## Adjusting the idle

- The engine idle speed does not require frequent adjustments but a few rules need to be observed when carrying out the adjustment.
- Before adjusting the carburettor, ensure that lubrication is efficient, that the play of the valves and the valve gear timing are correct, that the spark plug is in excellent condition, that the air filter is clean and tight, and that the exhaust system is perfectly tight.

- Warm up the engine by riding for at least ten minutes. The speed should be as close as possible to the top speed of the vehicle.
- Connect the vehicle to the exhaust gas analyser by inserting the analyser probe into an extension tube fitted tightly into the silencer exhaust.

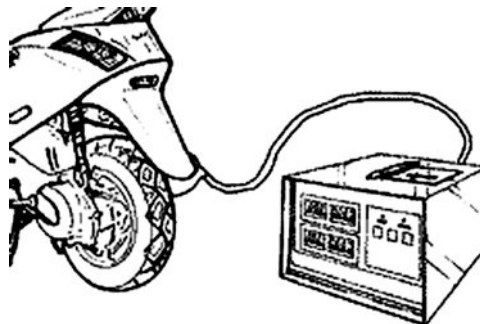

**N.B.**

**THE EXTENSION TUBE IS REQUIRED TO AVOID TAKING IN EXHAUST GAS CONTAMINATED BY THE AMBIENT OXYGEN. IT IS ESSENTIAL TO USE A PREVIOUSLY HEATED EXHAUST GAS ANALYSER CAPABLE OF RESETTING THE EXHAUST GAS READING AND ENSURE PROPER GAS DELIVERY.**



---

**FAILURE TO OBSERVE THESE RULES WILL RESULT IN INCORRECT READINGS.**

### Characteristic

#### Tube optimum length

40 - 50 cm

- 
- Connect the multimeter thermometer to the sump using an oil filler plug specially prepared for the insertion of the probe.
  - Start the engine and, before proceeding to tune up the idle speed, ensure that the oil temperature is 70-80° C.

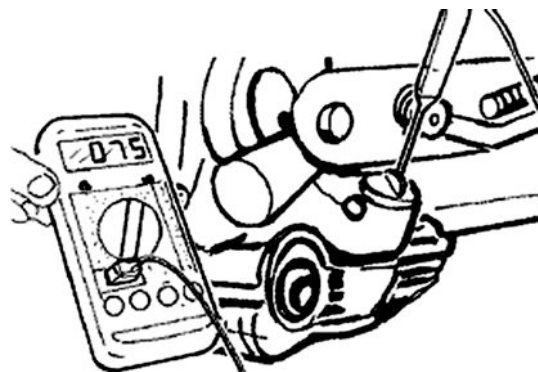

### Specific tooling

#### 020331Y Digital multimeter

- 
- Using the analyser revolution counter, or a separate instrument, turn the idle-speed adjusting screw until the engine .

**N.B.**

**THE IGNITION SYSTEM IS OF THE LOST-SPARK TYPE AND SUPPLIES CONSIDERABLE POWER. THE ENGINE SPEED MAY BE DIFFICULT TO READ ON UNDEDICATED REVOLUTION COUNTERS.**

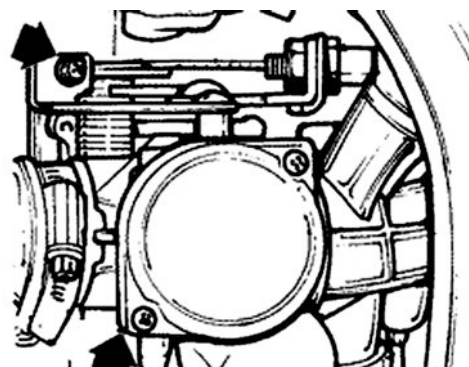

### Specific tooling

#### 020332Y Digital rpm counter

### Characteristic

#### idles at

1900/2000 g/min.

- 
- Adjust the flow screw until the carbon monoxide (CO) percentage is  $2.5 \pm 0.5$  percent. Loosening the screw increases the CO concentration (rich mixture); conversely, tightening the screw reduces the CO concentration (lean mixture). - If the adjustment of the flow screw results in a high-

er engine speed, adjust the rpm again and if necessary the flow screw until the engine speed stabilizes.

**Characteristic****CO**

2,5 ± 0,5%

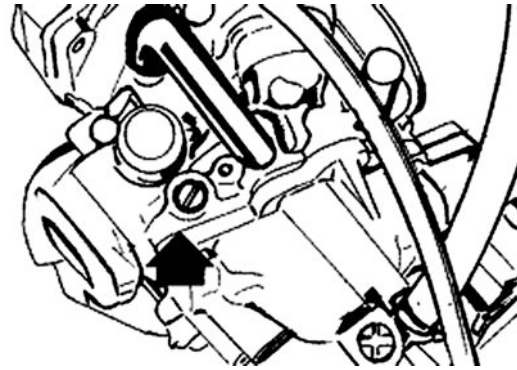

- Idle-speed carburetion is considered to be correct when the oil temperature, the engine speed and the carbon monoxide percentage are as specified. The analyser provides further information:

- The carbon dioxide (CO<sub>2</sub>) percentage has a reverse tendency to the carbon monoxide (CO) percentage. Correct concentrations exceed 13 percent. Lower values denote poor seal of the exhaust system.

- Unburnt hydrocarbons (HC) are measured in parts per million (PPM). HC concentrations decrease as the engine speed increases. Normal values at idle speed range from 200 to 400 PPM. These values are to be regarded as normal for an engine with a motorcycle-type distribution diagram. Much higher values can be due to misfiring resulting from an excessively lean mixture (low CO values), ignition malfunctions, incorrect valve gear timing, a sticky or leaky exhaust valve.

If the CO percentage is difficult to adjust, carefully check:

- If the automatic starting device is in working order.
  - If the conical needle is working properly in its seat.
  - If the level in the float chamber is correctly adjusted.
-

## INDEX OF TOPICS

SUSPENSIONS

SUSP

---

## Front

---

### Removing the front wheel

---

-Remove the five socket-head screws fastening the wheel to the hub.

**N.B.**

**REMOVE THE BRAKE CALLIPER BEFORE REMOVING THE WHEEL HUB.**

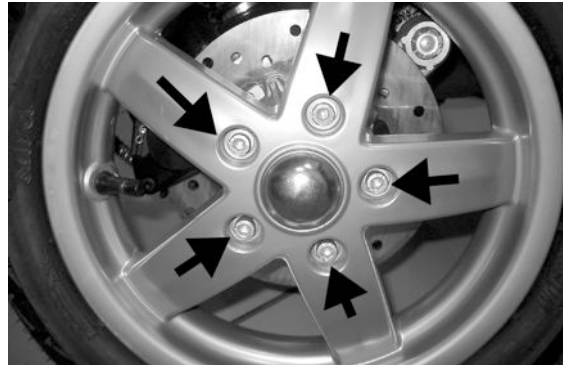

---

### Front wheel hub overhaul

---

- Remove the ball bearing lock snap ring shown in the figure



Using the specific tool, remove the ball bearing.

#### Specific tooling

**001467Y014 15 mm pliers**

**001467Y017 Bell for bearings external Ø 39 mm**



- Using a screwdriver, remove the oil guard on the roller bearing side.

---



Using the specific tool, remove the roller bearing

### Specific tooling

**020376Y Handle for punches**

**020456Y Ø 24 mm adapter**

**020363Y 20mm guide**



- Using a thermal gun, warm the roller bearing seat

- Using the specific tool, insert the bearing with the screened side facing outwards and move it to travel end

- Replace the ball bearing lock snap ring

### Specific tooling

**020151Y Air heater "METABO HG 1500/2"**

**020376Y Handle for punches**

**020359Y 42 x 47 mm hub bearing fitting adaptor**

**020412Y 15 mm guide**



- Using the specific tool, insert the roller case and move it to travel end

- Replace the oil guard on the roller bearing side

- Apply grease between ball and roller bearings

### Specific tooling

---

**020038y Drift****Recommended products****JOTA 3 FS Speedometer transmission**

Lithium soap grease NLGI 33



---

**Refitting the front wheel**

- Reassembly, tighten the five screws to the prescribed torque.

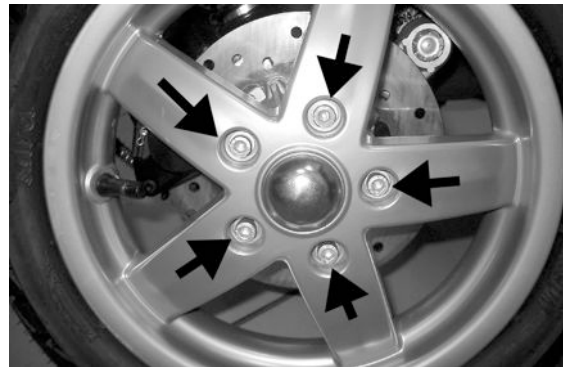
**Locking torques (N\*m)****Nut tightening torque 20 ÷ 25 N·m**

---

**Handlebar**

---

**Removal**

- Before proceeding, remove the handlebar fairing.
- After detaching flexible transmission cables and disconnecting electrical terminals, loosen the clamp securing the handlebar to the steering tube
- Check all components and replace any damaged or defective parts.

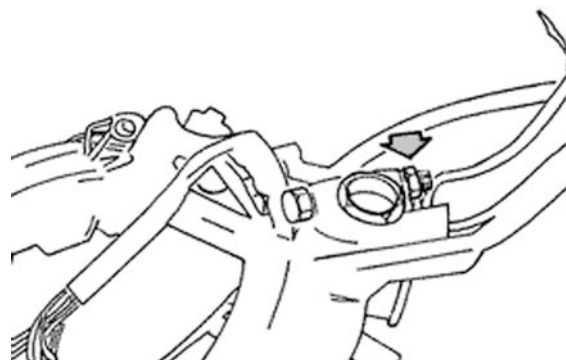
**N.B.**

**IF YOU ARE REMOVING THE HANDLEBAR ONLY SO THAT YOU CAN THEN REMOVE THE STEERING ASSEMBLY, SIMPLY ALLOW THE HANDLEBAR TO TIP OVER THE FRONT OF THE SCOOTER, TAKING CARE THAT FLEXIBLE TRANSMISSION CABLES ARE NOT DAMAGED.**

---

## Refitting

---

Follow the operations for removal in reverse, observing the prescribed tightening torques.

### Locking torques (N\*m)

Handlebar fastening screw  $45 \div 50$  N·m

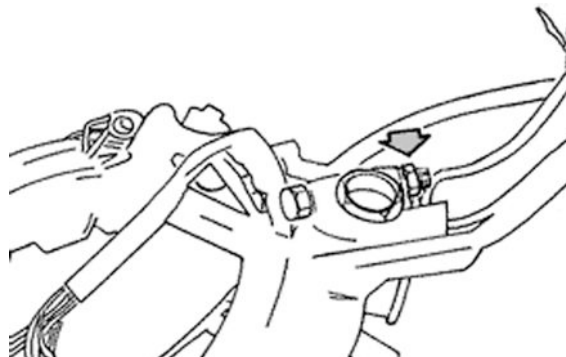

---

## Steering column

---

### Removal

After removing the top seat, tilt the vehicle on a side and extract the steering tube with fork.

### Specific tooling

**020055Y Steering tube ring nut spanner**



---

## Overhaul

---

- Use the tool equipped with parts 3 and 4 and turn the tool handle until the washers are wedged into the trailing link.

- Remove spacers, part 17, and pack the clearance between the steering tube and the trailing link with grease. Now slide the dust seals into position.

\* Supplied with the tool

**N.B.**

**THE LOWER SEAT ON THE STEERING COLUMN TUBE MUST BE MOUNTED WITH THE HELP OF A**

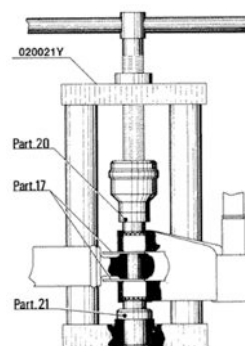

**CROP END WITH AN APPROPRIATE DIAMETER.**

**Specific tooling**

**020021y Front suspension overhaul kit**

**001330Y Steering seat installer, to be fitted with parts: 001330Y009-For lower seat, 001330Y013-For upper seat**

**Recommended products**

**ZETA 2 Grease for steering wheel bearings and pin seats**

Lithium soap and zinc oxide grease NLG12

-Use the special tool equipped with parts 20\* and 21\* as shown in the figure.

-Turn the handle to force the base of the needle bearings into contact with the end of the pin.

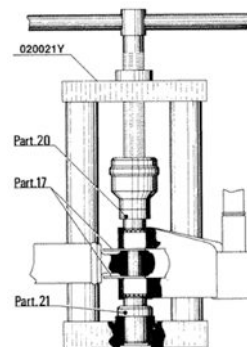

-Lubricate the oil seals with mineral oil and half-fill the needle bearings with grease.

-Fit the oil seal and the needle bearing on the pin, complete with retaining washer.

-Remove the special tool and then remove part 5 (guide) which was partially expelled in the previous assembly step. Leave part 4\* mounted on the tool.

-Remove part 3 from the tool and replace it with part 16\*.

-Turn the tool handle to insert the retaining washer - needle bearing - seal ring assy. until part 16 comes into contact with the trailing link.

- To fit the second retaining washer - needle bearing - seal ring assy. repeat the above operation

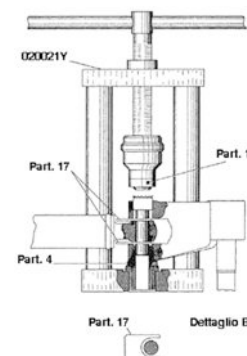



with the tool on the opposite side to that shown in the figure, still equipped with part 16 and with part 22\* instead of part 4.

\* supplied with the tool

### Specific tooling

#### 020021y Front suspension overhaul kit

#### Recommended products

#### ZETA 2 Grease for steering wheel bearings and pin seats

Lithium soap and zinc oxide grease NLG12

- Fit the two dust seals «C» on the trailing link as shown in detail «A».
- Connect the trailing link to the steering tube by means of guide pin 5\*.
- Apply the special tool equipped with part 3\* on the shaft and part 4\* at the bottom.
- Smear Z2 grease on the pin and insert it into the trailing link and turn the tool handle until part 3 locates against the steering tube.
- After fitting the pin, insert the two spacers, part 17\*, by tapping lightly with a mallet (see following figure).

\* supplied with the tool

### Specific tooling

#### 020021y Front suspension overhaul kit

#### Recommended products

#### ZETA 2 Grease for steering wheel bearings and pin seats

Lithium soap and zinc oxide grease NLG12

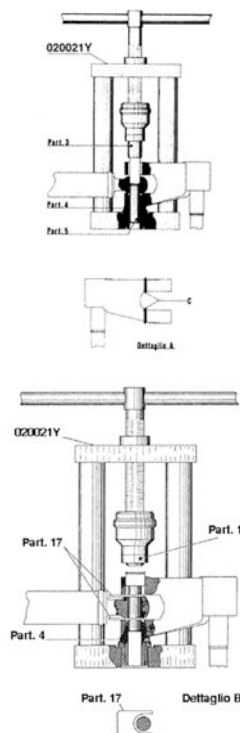

- Apply the special tool fitted with part 1\* and turn the handle until both the pin and the needle bear-

ing opposing the force exerted by the tool are expelled at the same time.

- To remove the second needle bearing, fit the tool with part 2\* working from the side opposite to the one shown in the figure.

\* supplied with the tool

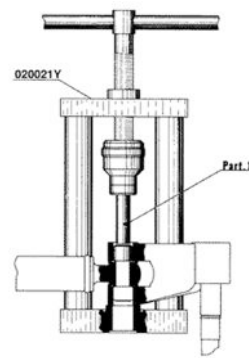

### Specific tooling

#### 020021y Front suspension overhaul kit

- Crush the retaining washer and remove it by means of a punch.

- Repeat the operation for the second washer using the punch on the opposite side to the one shown in the figure.

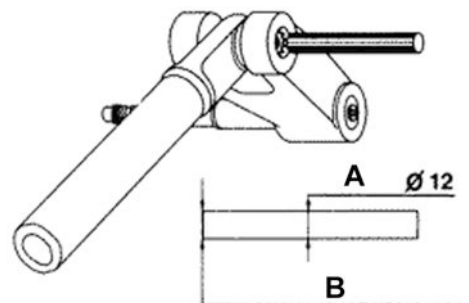

**A** = Punch  $\varnothing 12$

**B** = Sharp edge end

- Overhauling the front suspension serves to renew the parts connecting the steering tube and the trailing link. This operation is only effective if both steering tube and trailing link are in perfect condition.

### Refitting

When assembling the steering tube apply the recommended grease on the steering fifth wheel.

Tighten lower ring nut "A" and upper ring nut "B" to the prescribed torque.

### Recommended products

**TUTELA ZETA 2 Grease for steering, seats of pin and swing arm**

Lithium soap and zinc oxide grease NLG12

---

**Locking torques (N\*m)**

Steering lower ring nut  $8 \div 10$  Steering upper  
ring nut  $35 \div 40$

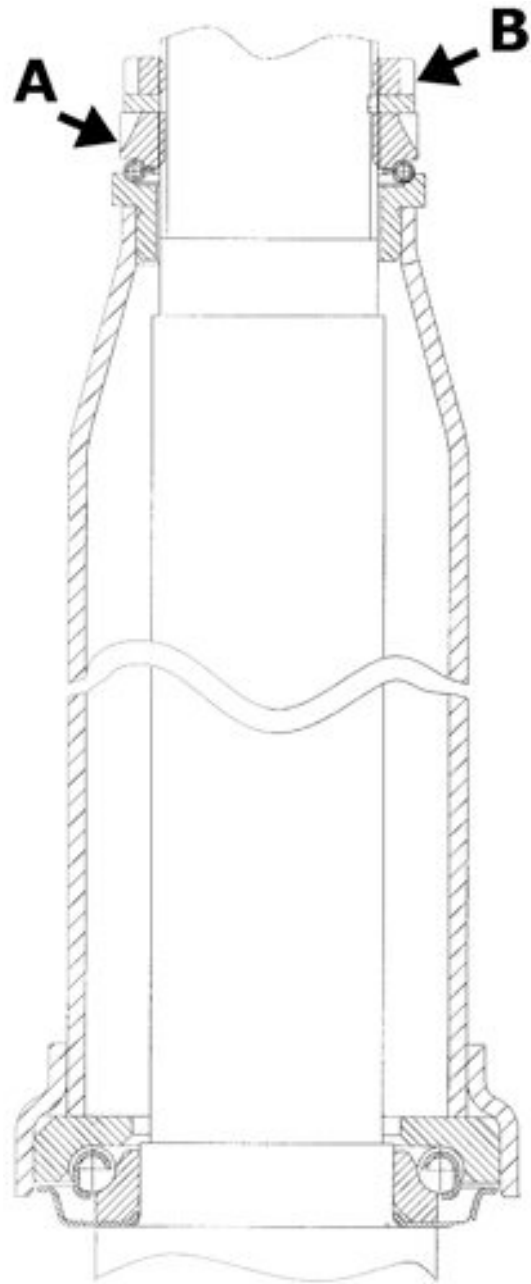

---

**CAUTION**

REASSEMBLE WITH NEW ROLLER BEARINGS, PIN, OIL SEALS AND DUST SEALS.

---

**Front shock absorber**

---

**Removal**

---

- Remove the steering tube

---

- 
- Remove the shock absorber bottom fixing screws
  - Remove the top shock absorber attachments



---

## Refitting

- For re-assembly, perform the operations for removal in the reverse order according to the tightening torques.

### Locking torques (N\*m)

Shock absorber top fixing **20 - 27 Nm** Shock absorber bottom fixing **20 - 30 Nm**

---

## Shock-absorber - calliper bracket

---

### Removal

- Remove the wheel hub with the brake disc
- Remove the front shock absorber bottom fixing screws



- 
- Remove the bracket lock snap ring
  - Extract the bracket



- 
- Before replacing the bracket into the wheel axle,

---

place the o-ring as shown in the figure in order to have a proper positioning of the same after the installation of the bracket.

- Replace the washer and the snap ring
- Replace the screws fixing the shock absorber to the bracket and tighten at the prescribed torque

**Locking torques (N\*m)****Shock absorber bottom fixing  $20 \div 27$  Nm**

---

**Overhaul**

- The caliper - shock absorber fixing bracket is provided with two roller bearings spaced from one another as shown in the figure



- Remove the two roller bearings from the bracket using the specific tool from the shock absorber coupling side, as shown in the figure

**Specific tooling****020376Y Handle for punches****020441y 26 x 28 mm adapter****020365y 22 mm guide**

- Remove the oil guard on the wheel hub side using a screwdriver as shown in the figure



- Suitably support the shock absorber - brake caliper bracket
- Using the specific tool, install a new oil guard and move it to travel end

**Specific tooling**

**020376Y Handle for punches**

**020360Y 52 x 55 mm adaptor**



- Using the specific tool, install a new roller bearing on the shock absorber side and move it to travel end

**Specific tooling**

**020036y Drift**



- Suitably support the shock absorber - brake caliper bracket
- Using the specific tool, install a new oil guard and move it to travel end

**Specific tooling**

**020037y Drift**



**Refitting**

- Using a suitable drift, drive out the two needle bearings from the side opposite to the assembly side.

**CAUTION**

**BEFORE REFITTING, USE GREASE IN THE AREAS MARKED WITH AN ASTERISK.**

**Specific tooling**

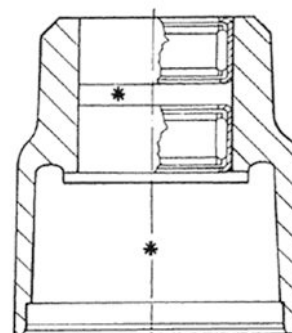

020036y Drift

020037y Drift

### Recommended products

**ZETA 2 Grease for steering wheel bearings and pin seats**

Lithium soap and zinc oxide grease NLG12

---

## Steering bearing

---

### Removal

- Use the special tool to remove the lower race of the top bearing and the upper race of the bottom bearing from the frame.

**N.B.**

**THE LOWER BEARING RACE CAN BE PRISED OFF BY LEVERING IT WITH A SCREWDRIVER OR SIMILAR.**

### Specific tooling

**020004Y Drift for removing thrust rings from steering head tube**

---

- Using the specific tool, remove the fifth wheel seat and the dust guard on the steering tube as shown in the figure. Proceed by slightly hitting with a mallet.



### Specific tooling

**020004Y Drift for removing thrust rings from steering head tube**

---

- Using the specific tool, replace the dust guard and the fifth wheel seat on the steering tube to abutment.



### Specific tooling

**006029y Drift for fitting thrust ring seats on steering tube**

---

---

## Rear

---

### Removing the rear wheel

- Straighten the split pin and remove.
- Remove the central nut as shown in the figure.

---

### Refitting the rear wheel

---

- Fit the wheel and tighten the central nut to the prescribed torque.
- Fit the nut cap and insert the split pin, peening over the ends as shown in the figure.

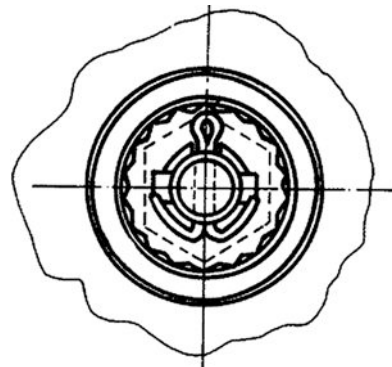

### Locking torques (N\*m)

Tightening torque  $137 \div 152$  N·m

---

## Swing-arm



---

## Removal

---

To remove the swing-arm, loosen the three fixings shown in the picture.

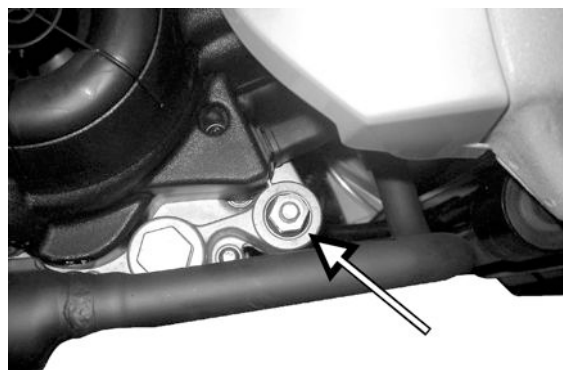





## Refitting

Upon refitting, tighten to the prescribed torque

**Locking torques (N\*m)**

**Component C 33 ÷ 41 Component B 44 ÷ 52**

**Component A 33 ÷ 41**

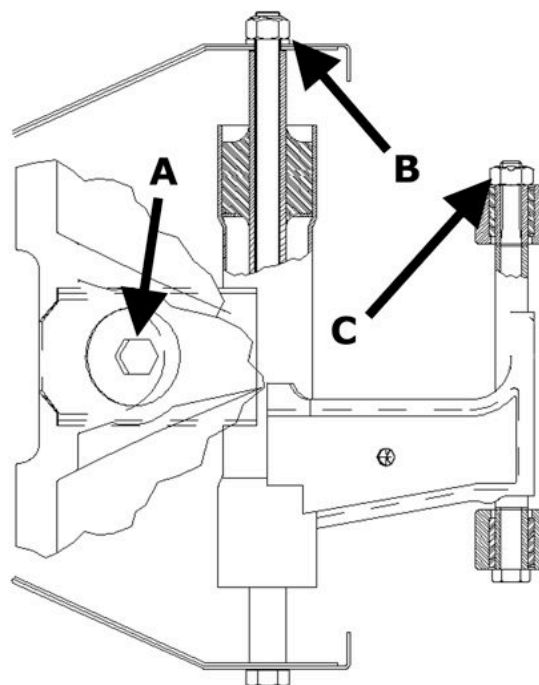

## Shock absorbers

## Removal

- To replace the shock absorber, it is necessary to remove the the battery access door, in order to gain access to the nut fixing the shock-absorber to the frame. Then, remove the bolt fixing the shock-absorber to the engine.

- Upon refitting, tighten the nut securing the shock-absorber to the frame, and the bolt fixing it to the engine, to the prescribed torque.

#### Locking torques (N\*m)

Shock absorber/engine pivot pin  $33 \div 41$  N·m

Shock absorber/frame nut  $20 \div 25$  N·m

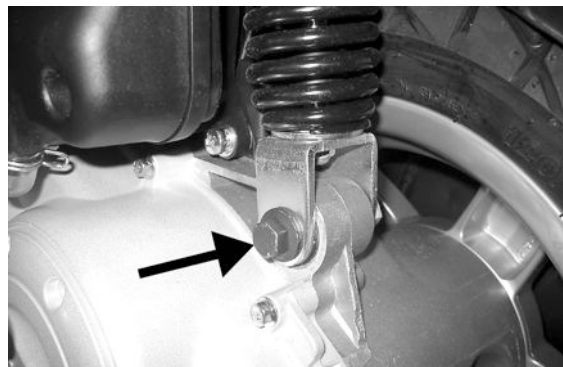

## **INDEX OF TOPICS**

**BRAKING SYSTEM**

**BRAK SYS**

- 1 - Reservoir cap
- 2 - Master cylinder
- 3 - Brake lever
- 4 - Master cylinder piston
- 5 - Flexible brake line
- 6 - Bleed screw cap
- 7 - Calliper
- 8 - Piston seal ring
- 9 - Plunger seal ring
- 10 - Piston
- 11 - Brake pad
- 12 - Brake disc

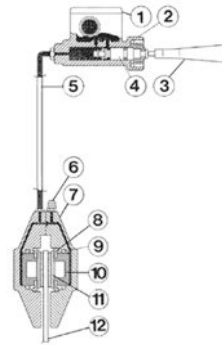

## Front brake calliper

### Removal

- Disconnect the brake tube and allow the fluid to flow into a container.
- Remove the screws shown in the figure.
- When reassembling, tighten the nuts to the prescribed torque.
- Bleed air from the brake circuit.

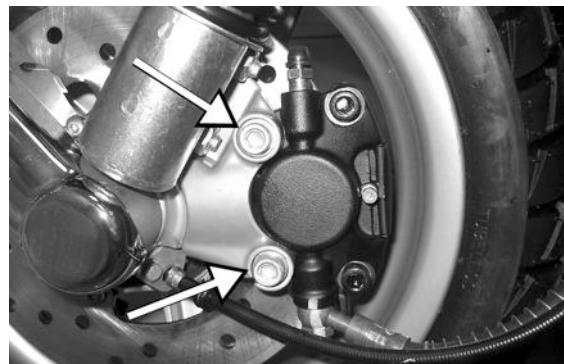

### Locking torques (N\*m)

Fixing screw 20 ÷ 25 Nm  
 Brake tube union 20 ÷ 22 Nm

### Overhaul

- Remove the calliper assembly bolts and take out the internal parts from both bodies. If necessary, use short blasts of compressed air through the brake fluid passage to facilitate expulsion of the pistons.
- Make sure the cylinders of the calliper inner and outer bodies are not scratched or eroded. If they are, renew the entire calliper.

#### CAUTION

**ALL INTERNAL COMPONENTS MUST BE RENEWED AT EACH CALLIPER OVERHAUL.**

Insert the following parts into the calliper bodies

- seal rings (1-2)
- pistons (3)
- O-ring (4) (in one of the bodies)
- Join the two bodies by means of the assembly bolts. Fit the pads and air bleed screw (see previous paragraphs).
- Position the calliper on the disc and fasten it to the hanger, tightening the bolts.
- Secure the brake tube union to the calliper and tighten to the prescribed torque.
- Before reassembly, the parts must be perfectly clean and **bear no traces of oil, diesel fuel, grease**, etc.. They must therefore be washed thoroughly in denatured alcohol before proceeding. **Immerse the seals in brake fluid**; the use of protective agent **PRF1** is tolerated.

#### CAUTION

**RUBBER PARTS MUST NOT BE LEFT IN ALCOHOL FOR MORE THAN 20 SECONDS. AFTER WASHING, DRY THE PARTS WITH COMPRESSED AIR AND A CLEAN CLOTH**

#### Locking torques (N\*m)

**Calliper to hanger: 20 ÷ 25 Calliper to tube union 25 ÷ 30**

**1 DUST SEALS**

**2 OIL SEALS**

**3 PISTONS**

**4 O-RING**

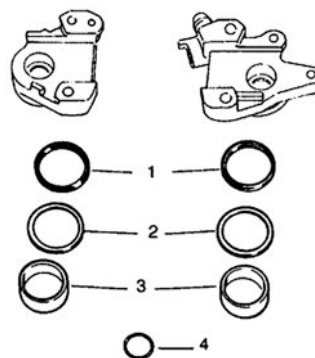

## Front brake disc

### Removal

- After replacing the brake disc smear the advised product the screw threads.
- Tighten to the prescribed torque.

#### N.B.

**THE DISC FACE WITH THE DIRECTION ARROW MUST FACE THE SHOCK ABSORBER**

---

### Recommended products

#### Loctite 242 product description

Apply thread-holding LOCTITE medium type 242

#### Locking torques (N\*m)

Tightening torque  $5 \div 6,5$  N.m

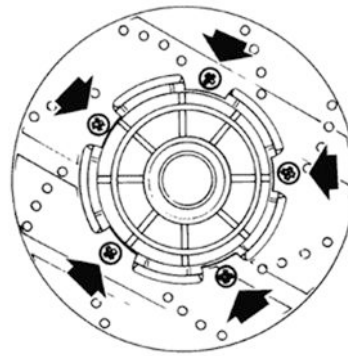

---

### Disc Inspection

#### Specific tooling

020335Y Magnetic stand and comparator

#### Characteristic

-Max. allowable wobble

mm 0,1.

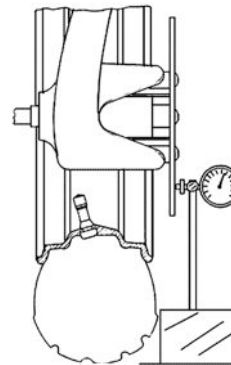

---

### Front brake pads

---

#### Removal

-Replace the brake pads when the friction material has come to its wear limit.

-To replace the pads it is necessary: remove the protection cover, the pin and the leaf spring. Take out the pads and replace them after sending the pistons back in. Fit the parts again by following the same steps in reverse order.



#### CAUTION

**BEFORE USING THE BRAKE, PULL THE LEVER FOR A FEW TIMES.**

---

### Front brake pump

## Removal

- Drain the brake fluid from the circuit through the bleeding screw on the calliper. Actuate the brake lever until the fluid stops flowing out.

- Remove the master cylinder from the handlebar, take off the brake lever and proceed to remove the brake cylinder.

1 - Reservoir cover screw

2 - Reservoir cover

3 - Membrane

4 - Bellows

5 - Sealing ring

6 - Piston

7 - Gasket

8 - Spring

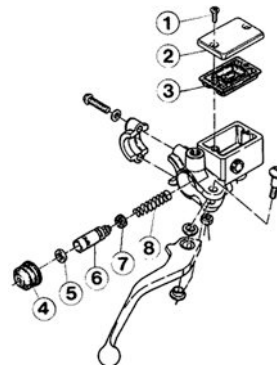

### CAUTION

**THE PRESENCE OF BRAKE FLUID ON THE DISC OR PADS REDUCES BRAKING ACTION. IN THIS CASE, RENEW THE PADS AND CLEAN THE DISC WITH A HIGH QUALITY SOLVENT.**

**CAUTION: BRAKE FLUID CAN DAMAGE PAINTWORK.**

**DO NOT LEAVE RUBBER PARTS IN ALCOHOL FOR MORE THAN 20 SECONDS.**

**AFTER WASHING, DRY THE PARTS WITH A BLAST OF COMPRESSED AIR AND A CLEAN CLOTH.**

**SEALING RINGS MUST BE IMMERSSED IN BRAKE FLUID.**

## Refitting

Before reassembly, the parts must be perfectly clean and bear no traces of oil, diesel fuel, grease, etc.. They must therefore be washed thoroughly in denatured alcohol before proceeding.

- Perform the disassembly steps in reverse order,

---

taking care to installed rubber parts correctly to ensure an oiltight seal.

- 1 - Reservoir cover screw
- 2 - Reservoir cover
- 3 - Membrane
- 4 - Bellows
- 5 - Sealing ring
- 6 - Piston
- 7 - Gasket
- 8 - Spring

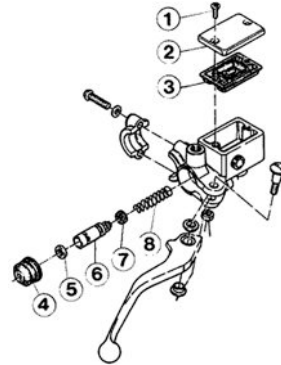

---

## Rear drum brake

After removing the muffler and wheel proceed as follows:

1. Remove the shoe spring using the specific pliers.
2. Remove the shoes using a lever.
3. Fit the new shoes using a mallet and hitting lightly.
4. Hook the spring using the specific pliers.

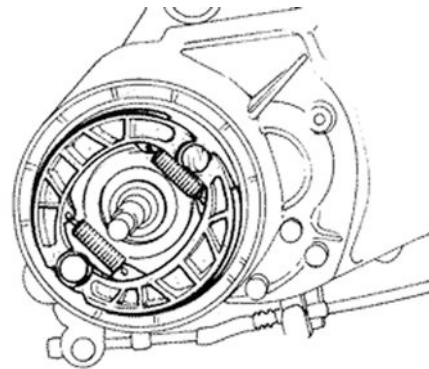

### Specific tooling

**020325y Pliers for brake-shoe springs**

---



## INDEX OF TOPICS

CHASSIS

CHAS

---

### Rear handlebar cover

---

Remove the handlebar rear fairing after loosening the screws as shown in the figure.

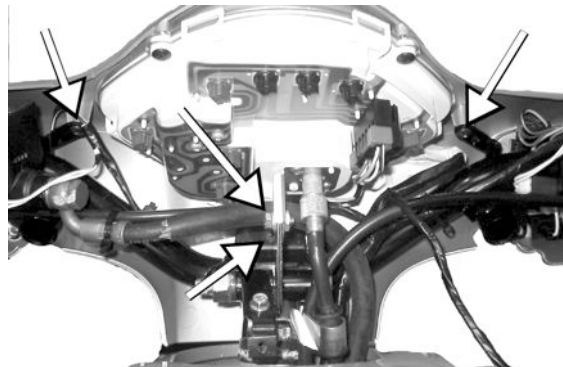

---

### Instrument panel

---

To replace the instrument panel, loosen the 4 screws shown in the figure.

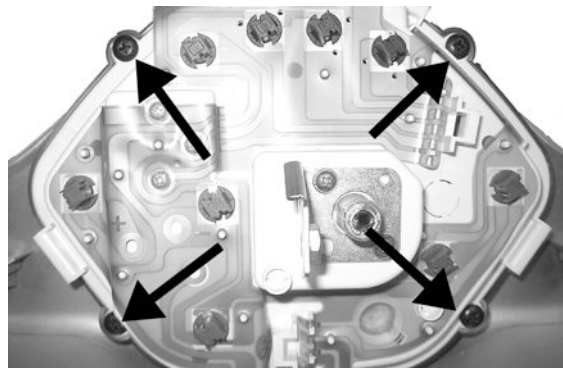

---

### Front handlebar cover

---

- Remove the 2 screws in the handlebar fairing and the screw under the headlight.
- Pull up to release the handlebar fairing and disconnect the headlight connections





### Headlight assy.

After removing the front handlebar cover, remove the 4 screws shown in the figure and remove the headlight.



### Knee-guard

- Loosen the two screws located under the front grille (see figure).
- Open the glove compartment door and remove the three screws located inside (see figure).

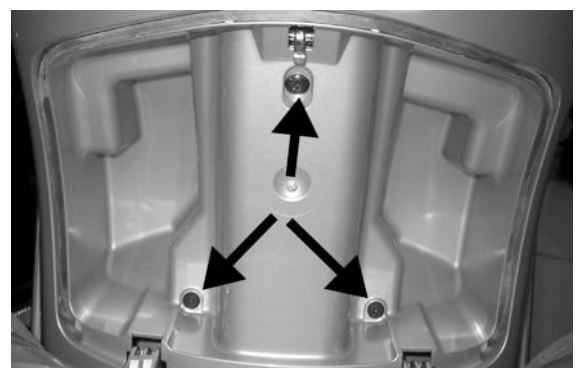
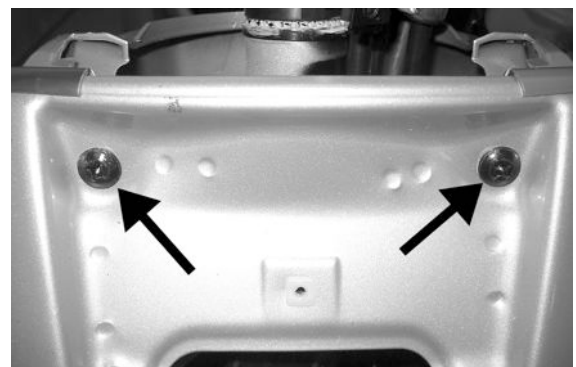

## Footrest

---

- Loosen the three screws shown in the figure after removing the glove compartment and the side fairings.

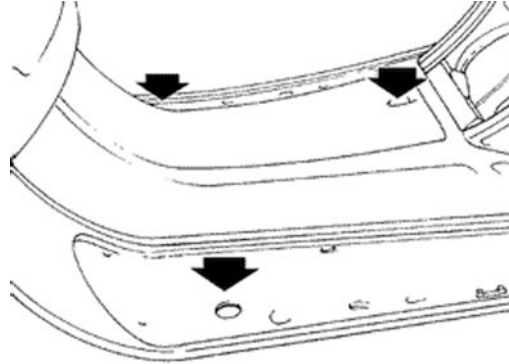

## Air filter

---

- Remove the helmet bay.
- After removing the side fairing, loosen the 2 screws shown in the figure and fix the air-box to the engine.
- Remove the two clamps shown in the figure.

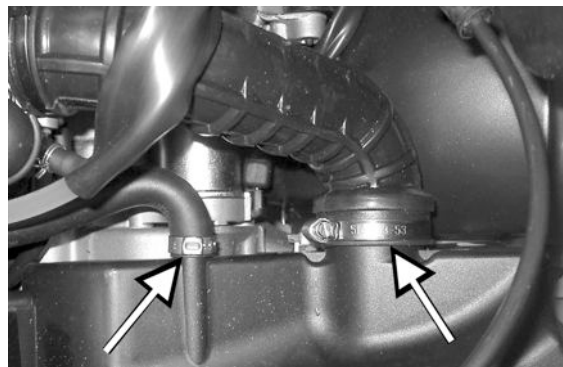
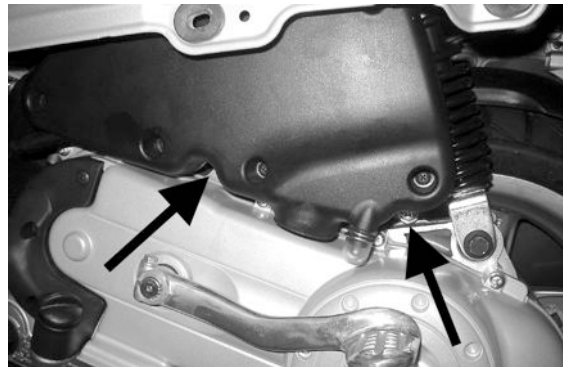

## Front mudguard

---

- To remove the front mudguard, remove the steering tube and release the front brake piping from the caliper
  - Then, remove the three attachments fixing the mudguard to the steering tube as shown in the
-

---

figure

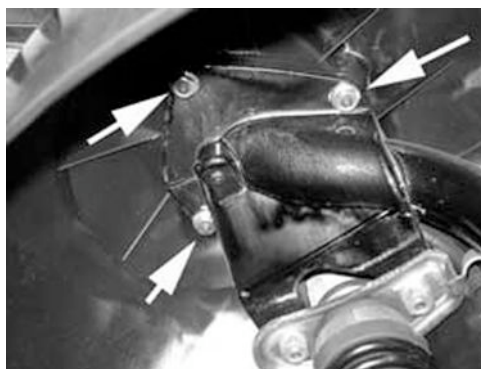

---

### Front central cover

- Remove the «PIAGGIO» logo
- Release the screw shown in the figure
- Remove the radiator grill

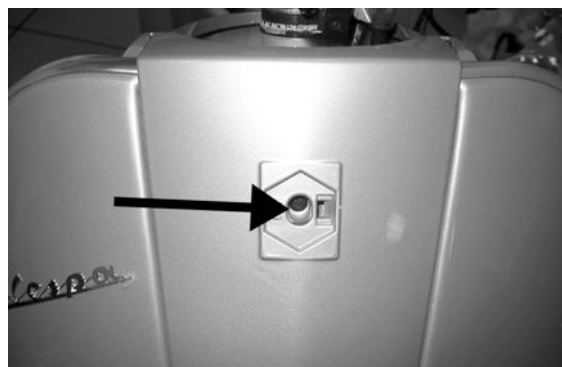
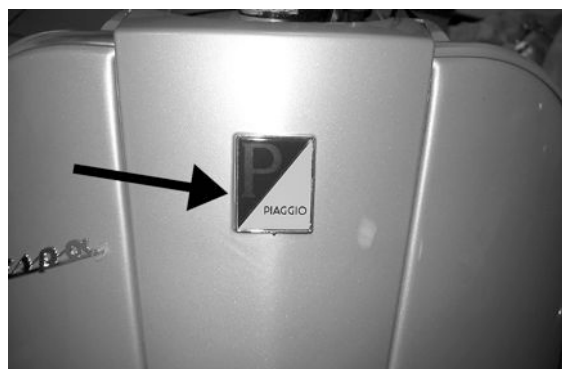



# INDEX OF TOPICS

PRE-DELIVERY

PRE DE

## Aesthetic inspection

- Paintwork
- Joins between plastic fairings
- Damage
- Cleanness

## Tightening torques inspection

### Fastenings check

- All tightening torques
- External fairing screws

### SAFETY LOCKS

Name	Torque in Nm
Handlebar tightening	40 ÷ 50
Steering lower collar	8 ÷ 10
Steering upper collar	30 ÷ 40
Front wheel spindle nut	75 ÷ 90
Rear wheel spindle nut	137 ÷ 152
Rear shock absorber-engine nut	33 ÷ 41
Frame-rear shock absorber nut	20 ÷ 25
Oscillating arm pin - engine	33 ÷ 41
Floating arm-frame pin	44 ÷ 52

## Electrical system

- Check that voltage is at least 12.6V; if not, recharge the battery according to directions.

Check the following devices:

- Keyswitch
- Headlight full/dipped beam, panel indicator lights, side lights
- Headlight adjustment
- Taillight
- Brake light (front and rear brake)
- Turn signals and relative indicators
- Speedometer and instrument panel lighting
- Horn



- 
- Start button

**CAUTION**

**TO ENSURE BEST PERFORMANCE, BATTERY MUST BE CHARGED BEFORE USE ONLY IF VOLTAGE IS BELOW 12,7V. FAILURE TO RECHARGE THE BATTERY BEFORE ITS FIRST USE MAY SHORTEN THE BATTERY'S LIFE.**

**WHEN INSTALLING THE BATTERY ON THE VEHICLE CONNECT THE POSITIVE LEAD BEFORE THE NEGATIVE LEAD.**

**NEVER USE A FUSE WITH A HIGHER RATING THAN THE PRESCRIBED VALUE. THE USE OF UNSUITABLY RATED FUSES CAN RESULT IN WIDESPREAD DAMAGE TO THE VEHICLE, INCLUDING FIRE.**

**WARNING**

**KEEP THE BATTERY WELL CLEAR OF NAKED FLAMES AND SPARKS DURING CHARGING. REMOVE THE BATTERY FROM THE VEHICLE BY DISCONNECTING THE NEGATIVE LEAD FIRST.**

**PROTECT THE EYES WHEN WORKING WITH BATTERIES OR IN THEIR IMMEDIATE VICINITY. KEEP BATTERIES AWAY FROM CHILDREN. BATTERY ELECTROLYTE CONTAINS SULPHURIC ACID. BATTERY ELECTROLYTE IS POISONOUS AND CAUSES SEVERE BURNS. AVOID CONTACT WITH THE EYES, SKIN AND CLOTHES. DO NOT FORCE OR DAMAGE THE EXTERNAL CASE.**

**IN CASE OF CONTACT WITH THE EYES AND/OR SKIN, WASH THE AFFECTED AREA WITH PLENTY OF CLEAN WATER FOR ABOUT 15 MINUTES AND SEEK MEDICAL ASSISTANCE IMMEDIATELY.**

**IN THE CASE OF INGESTION OF ELECTROLYTE DRINK PLENTY OF WATER OR VEGETABLE OIL AND CALL A DOCTOR IMMEDIATELY.**

---

**Levels check**

- Brake fluid
- Hub oil
- Engine oil level

---

**Road test**

- Cold start.
- Speedometer check.
- Throttle check.
- Riding stability.
- Front and rear brake efficiency.
- Front and rear shock-absorbers.
- Anomalous noises.
- Hot engine restart.
- Leakages (after road-test).

---

## Functional inspection

- Brake lever excursion.
- Throttle excursion and adjustment.
- Homogeneous steering turning.

### Other

- Tyre inflation pressure
- Locks
- Mirrors and accessories
- Toolkit, user handbook, guarantee certificate and customer service card

#### CAUTION

**CHECK THE INFLATING PRESSURES WHEN THE TYRES ARE AT AMBIENT TEMPERATURE.**

#### CAUTION

**NOT EXCEED THE RECOMMENDED INFLATING PRESSURES AS THE TYRES MAY BURST.**

#### WARNING

**BE VERY CAREFUL WHEN HANDLING FUEL.**

---

# INDEX OF TOPICS

TIME

TIME

---

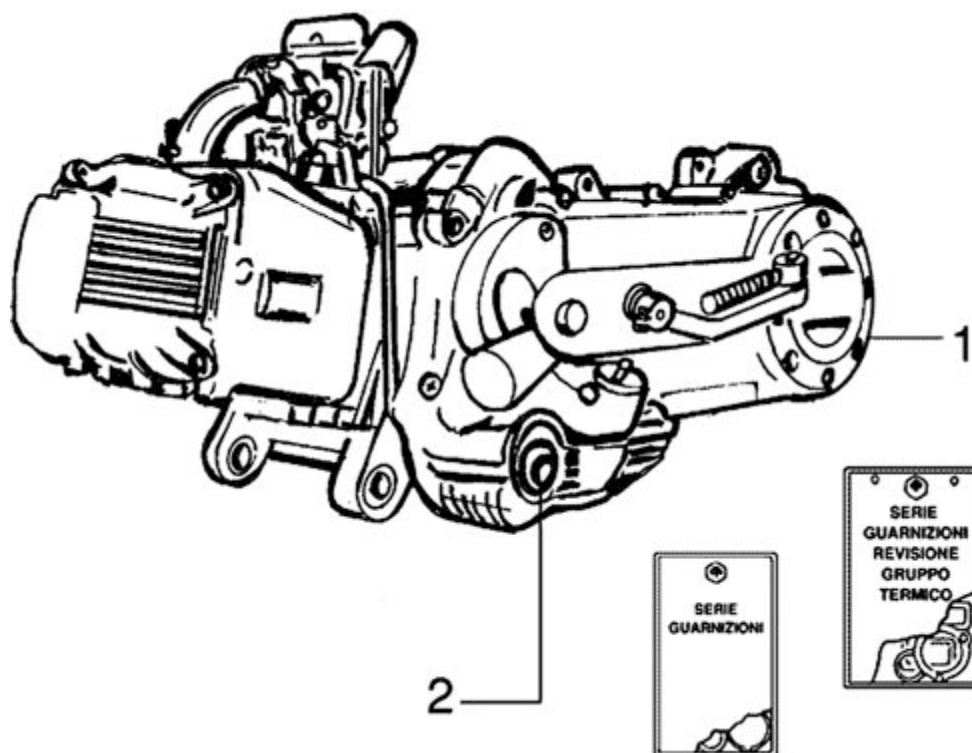
**Engine**
**ENGINE**

	Code	Action	Duration
1	001001	Engine to frame - Disassembly and reassembly	
2	003064	Engine oil - change 3	

---

**Crankcase**

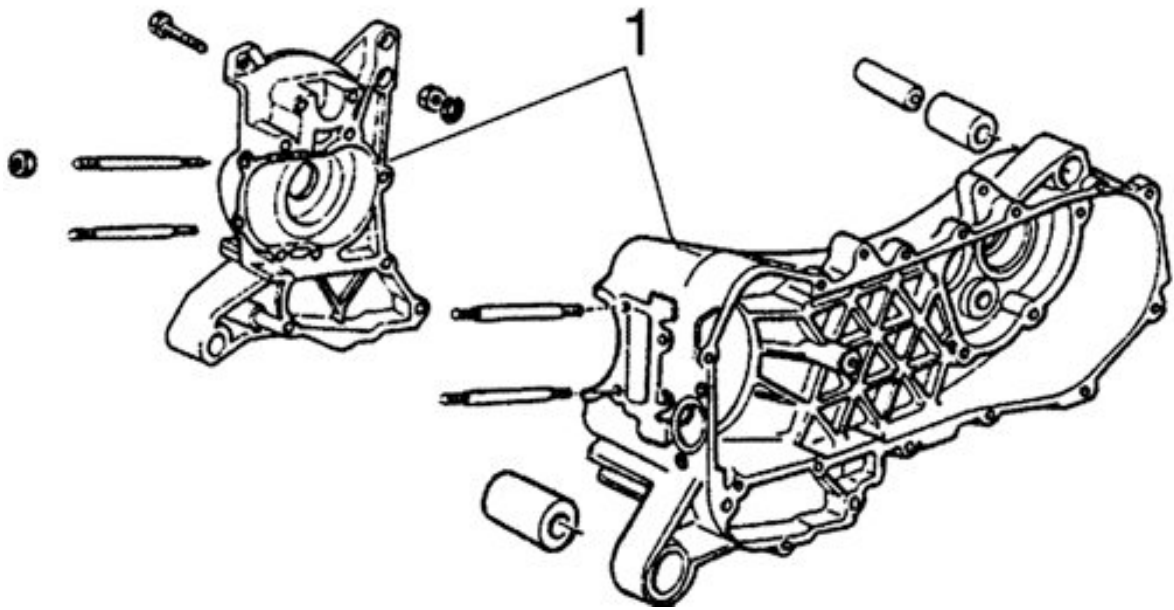

**CRANKCASE**

	Code	Action	Duration
1	001133	Engine crankcase - Replacement	

**Crankshaft**

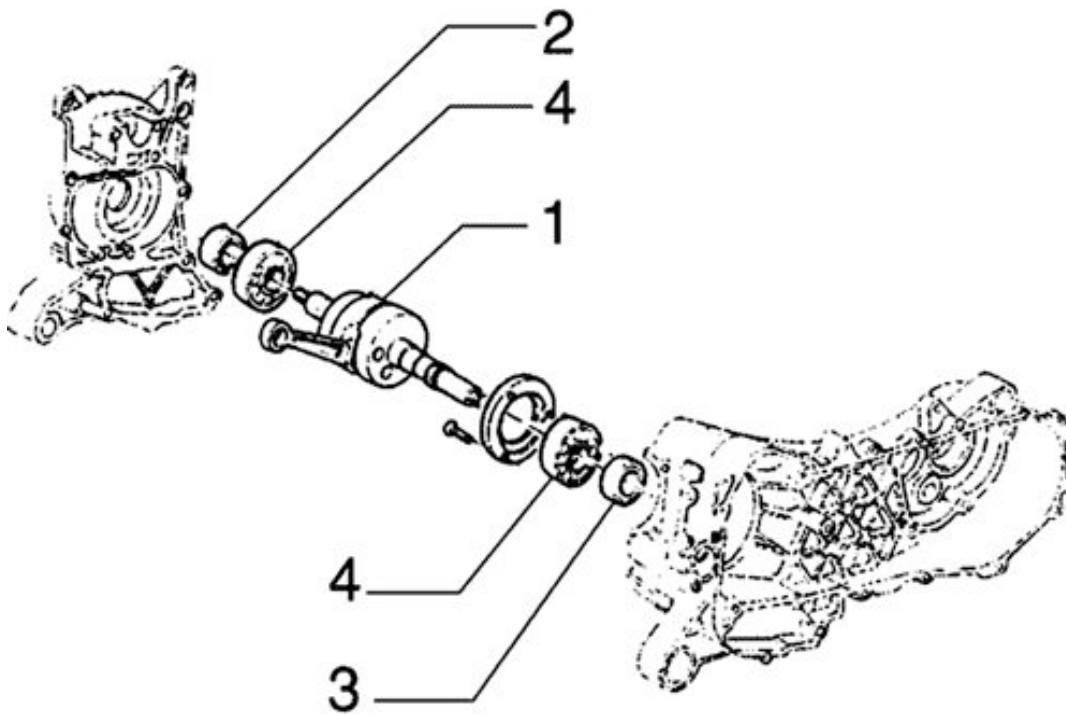

**DRIVING SHAFT**

	Code	Action	Duration
1	001117	Driving shaft - Replacement	
2	001099	Oil seal flywheel side - Replacement	
3	001100	Oil seal clutch side - Replacement	
4	001118	Main bearings - Replacement	

### Cylinder assy.

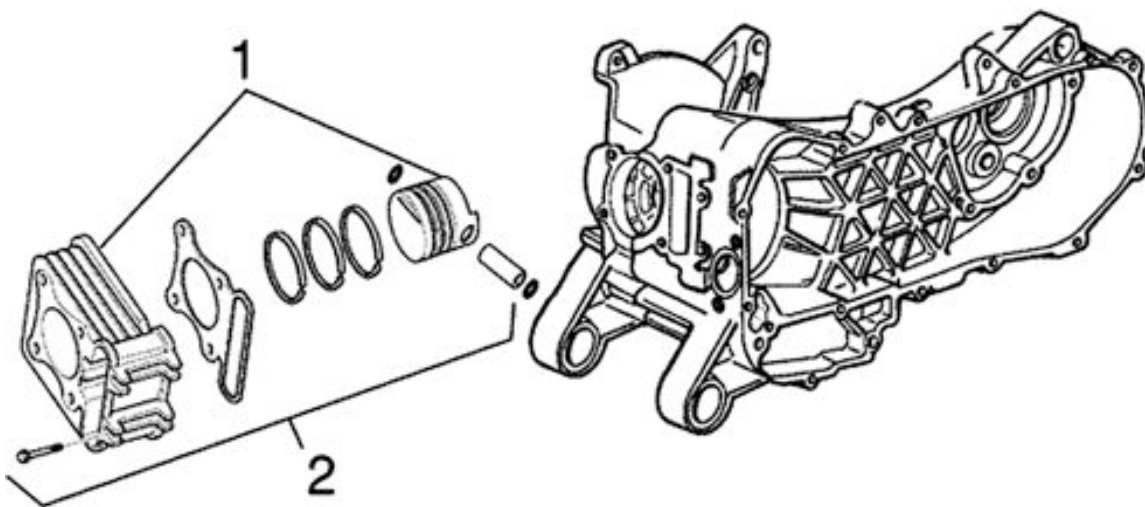

### PISTON CYLINDER

	Code	Action	Duration
1	001002	Piston cylinder - Replacement	
2	001107	Cylinder, piston - Overhaul/ Cleaning	

### Cylinder head assy.

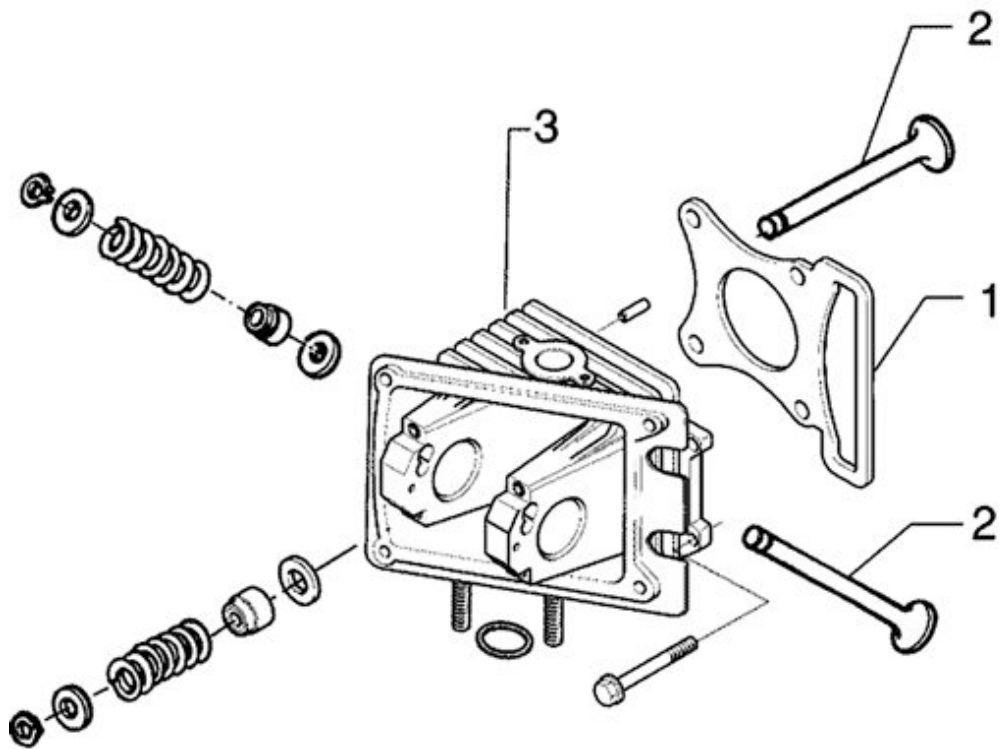

**HEAD**

	Code	Action	Duration
1	001056	Head gasket - Replacement	
2	001045	Valves - Replacement	
3	001126	Head - Replacement	

**Rocker arms support assy.**

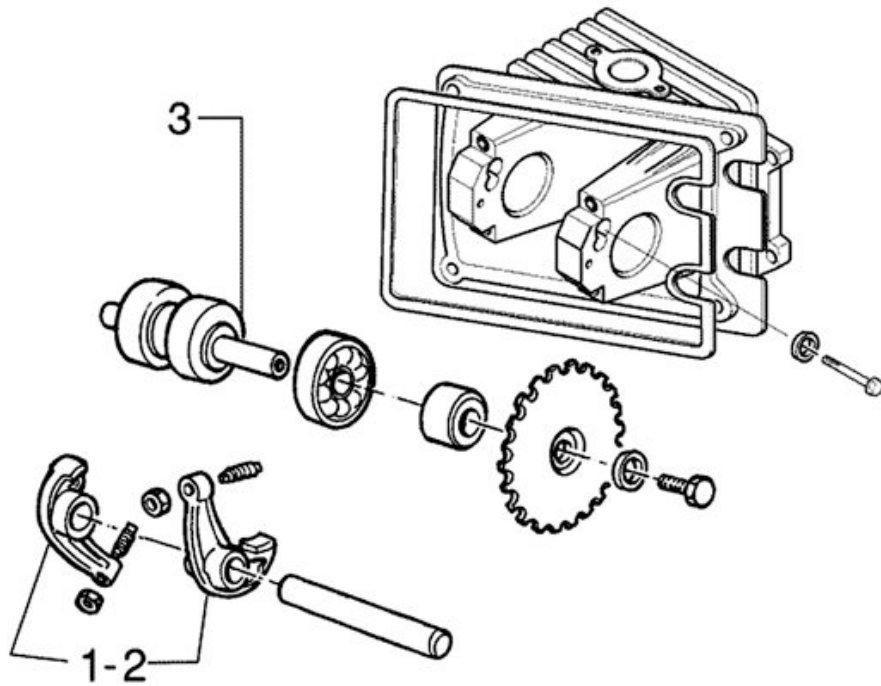

### CAMSHAFT SUPPORT

	Code	Action	Duration
1	001049	Valves - Adjustment	
2	001148	Valve rockers - Replacement	
3	001044	Camshaft - Replacement	

### Cylinder head cover



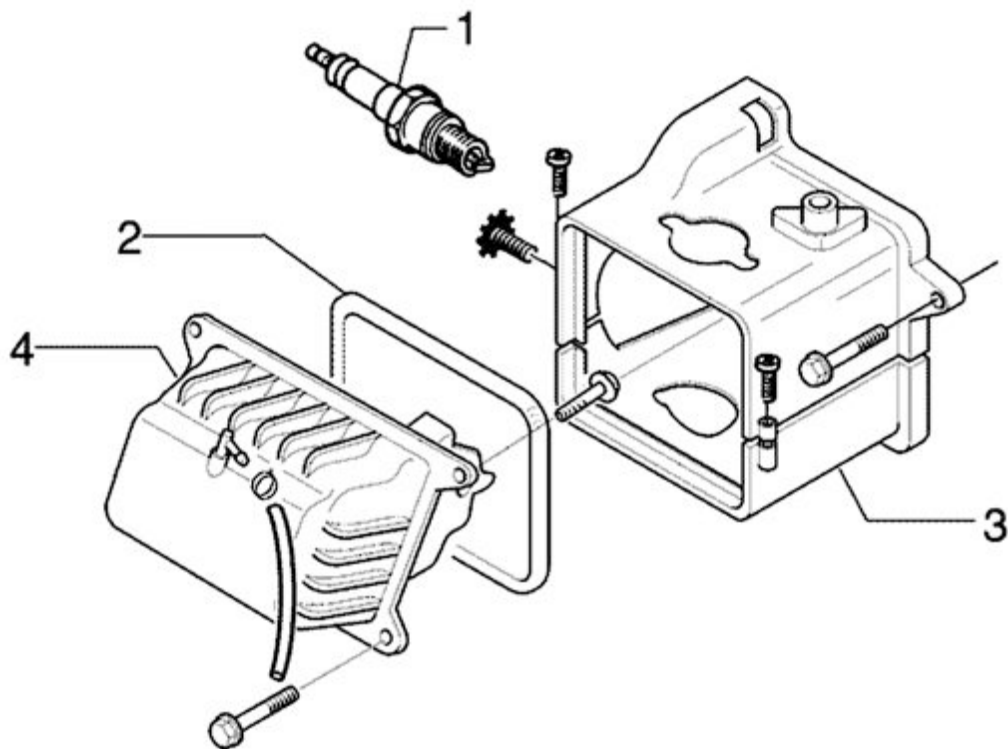

**HEAD COVER**

	<b>Code</b>	<b>Action</b>	<b>Duration</b>
1	001093	Spark plug - Replacement	
2	001088	Head cover gasket - Replacement	
3	001097	Cooling case - Replacement	
4	001089	Head cover - Replacement	

**Driven pulley**

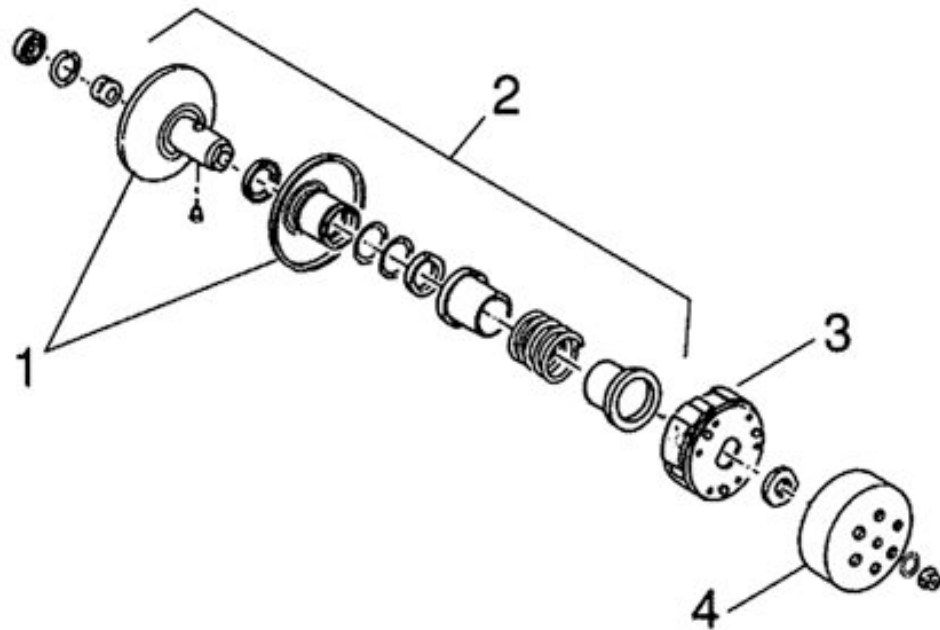

**CLUTCH BELL HOUSING - CLUTCH**

	<b>Code</b>	<b>Action</b>	<b>Duration</b>
1	001110	Driven pulley - Replacement	
2	001012	Driven pulley - Overhaul	
3	001022	Clutch - Replacement	
4	001155	Clutch bell housing - Replacement	

**Oil pump**

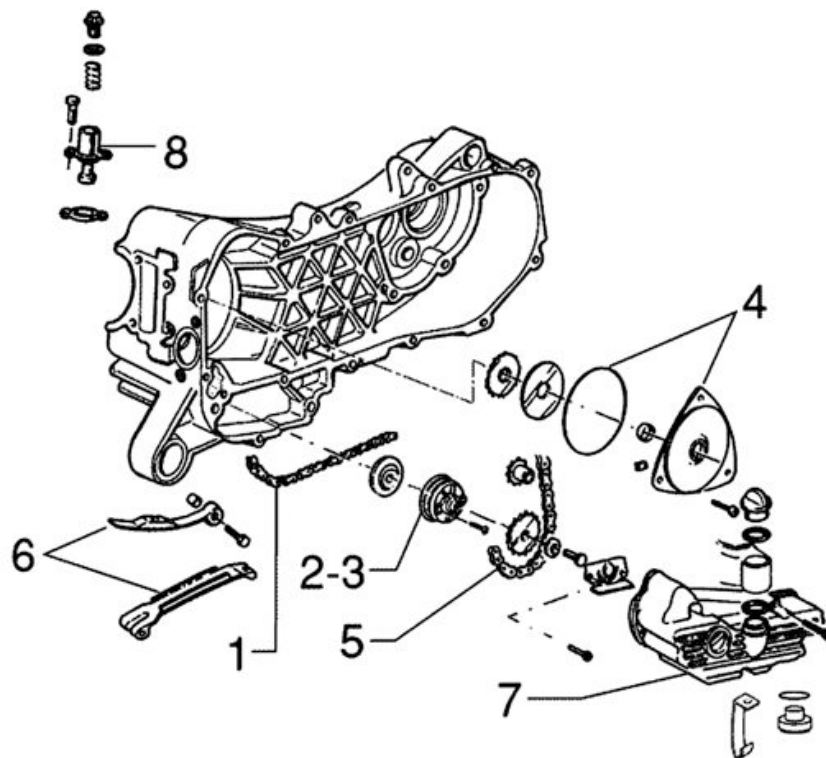

**OIL PUMP**

	<b>Code</b>	<b>Action</b>	<b>Duration</b>
1	001051	Belt/Timing chain - Replacement	
2	001112	Oil pump - Replacement	
3	001042	Oil pump - Overhaul	
4	001121	Chain cover oil retainer - Replacement	
5	001122	Oil pump chain - Replacement	
6	001125	Chain guide pads - Replacement	
7	001130	Oil pan - Replacement	
8	001129	Chain tightener - Overhaul and replacement	

**Final gear assy.**

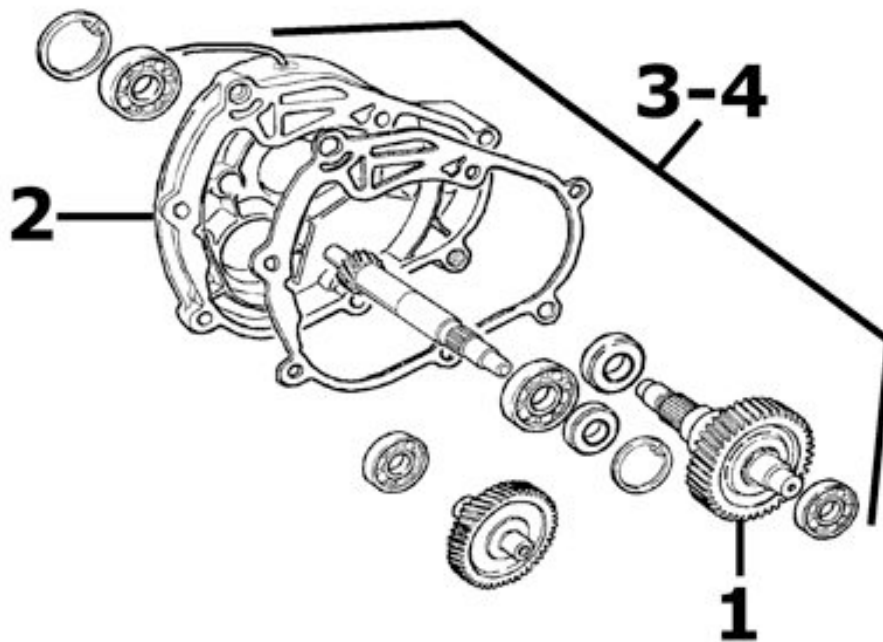

### REDUCTION GEAR

	Code	Action	Duration
1	004125	Rear wheel axle - Replacement	
2	001156	Geared reduction unit cover - Replacement	
3	003065	Gearcase oil - Replacement	
4	001010	Reduction gear - Overhaul	

### Driving pulley

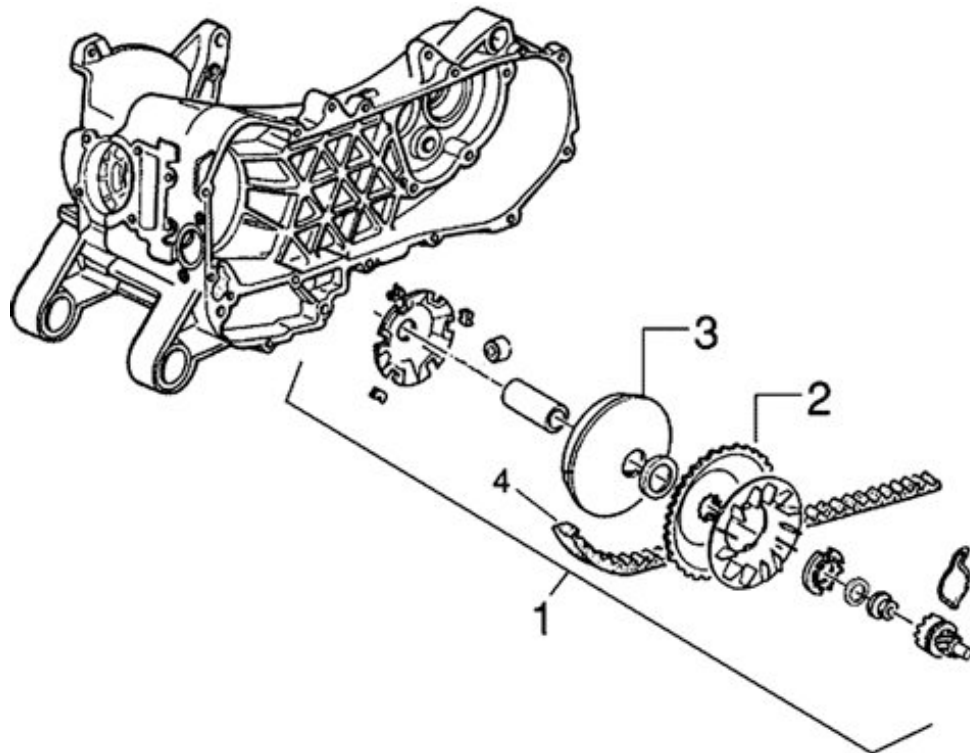

**DRIVING PULLEY**

	<b>Code</b>	<b>Action</b>	<b>Duration</b>
1	001177	Rollers / Variator track shoes - Replacement	
2	001086	Driving half pulley - Replacement	
3	001066	Driving pulley - Disassembly and reassembly	
4	001011	Driving belt - Replacement	

**Transmission cover**

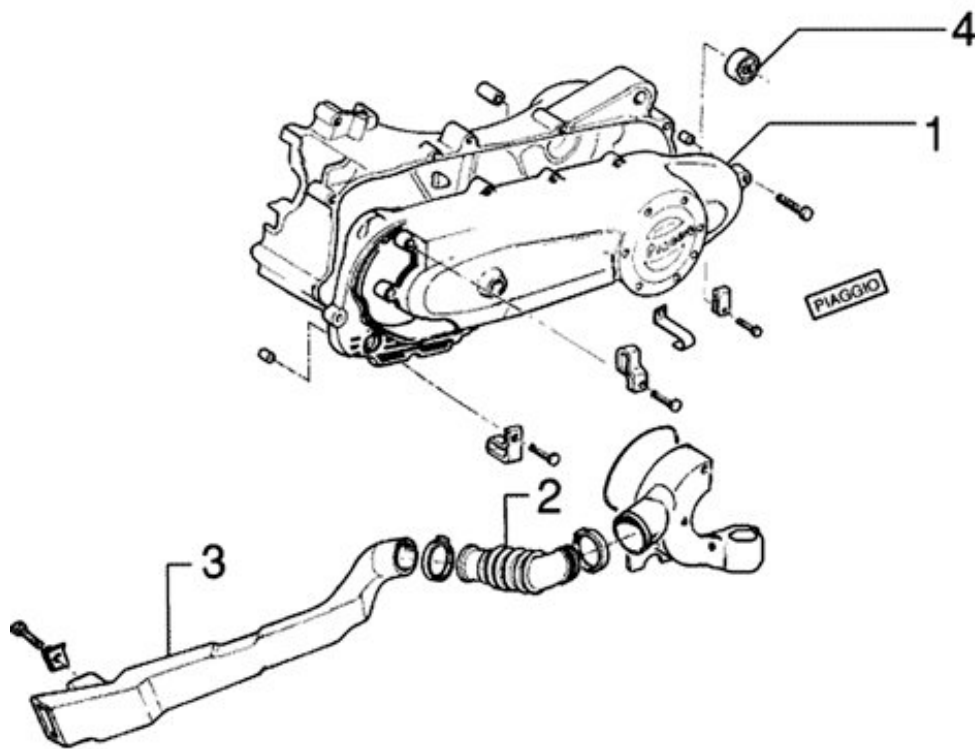

### TRANSMISSION COVER

	Code	Action	Duration
1	001096	Transmission casing cover - Replacement	
2	001132	Transmission air intake tube - Replacement	
3	001131	Transmission air intake - Replacement	
4	001135	Transmission cover bearing - Replacement	

### Starter motor

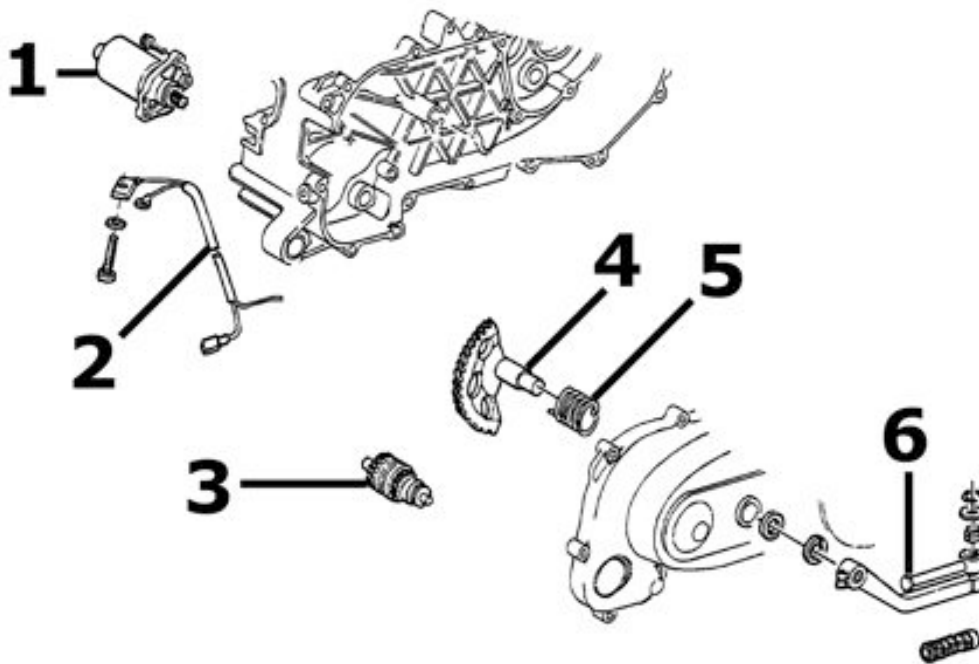

**ELECTRIC START**

	Code	Action	Duration
1	001020	Starter engine - Replacement	
2	005045	Starting motor cables - Replacement	
3	001017	Starter pinion - Replacement	
4	001021	Kick starter - Overhaul	
5	008008	Starting sector spring - Replacement	
6	001084	Starting lever - Replacement	

**Flywheel magneto**

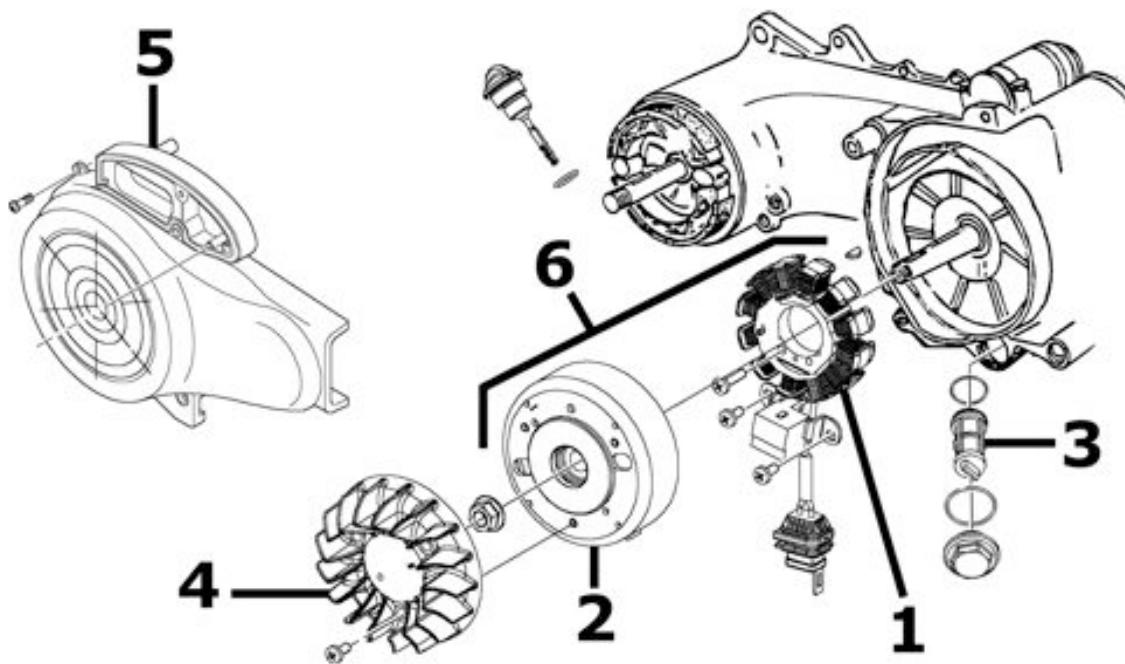

### FLYWHEEL MAGNETO

	Code	Action	Duration
1	001067	Stator - Disassembly and re-assembly	
2	001173	Rotor - Replacement	
3	001102	Net oil filter - Replacement and cleaning	
4	001109	Cooling fan - Replacement	
5	001087	Flywheel housing - Replacement	
6	001058	Flywheel - Replacement	

### **Carburettor**



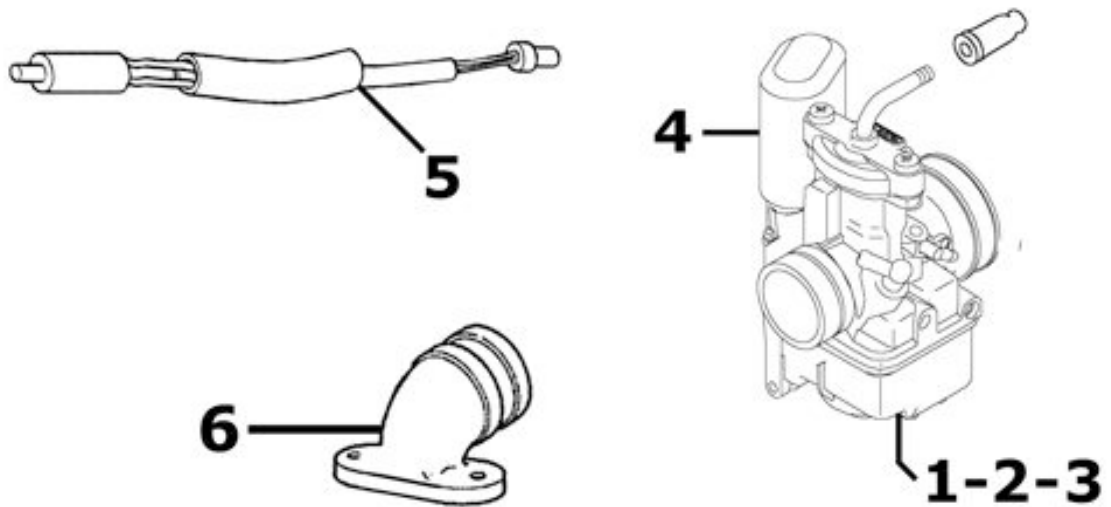

**CARBURETTOR**

	<b>Code</b>	<b>Action</b>	<b>Duration</b>
1	001063	Carburettor - Replacement	
2	001008	Carburettor - Overhaul	
3	003058	Carburettor - Adjustment	
4	001081	Automatic starter device - Replacement	
5	001082	Carburettor heating resistor - Replacement	
6	001013	Intake manifold - Replacement	

**Exhaust pipe**

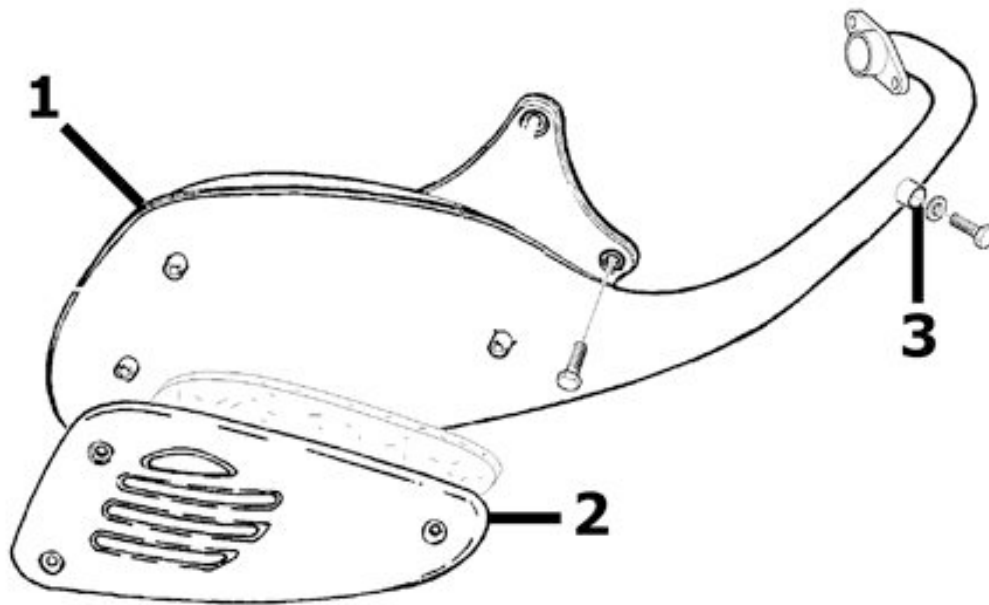
**MUFFLER**

	Code	Action	Duration
1	001009	Silencer - Replacement	
2	001095	Silencer guard - Replacement	
3	001136	Exhaust emissions - Adjustment	

**Air cleaner**

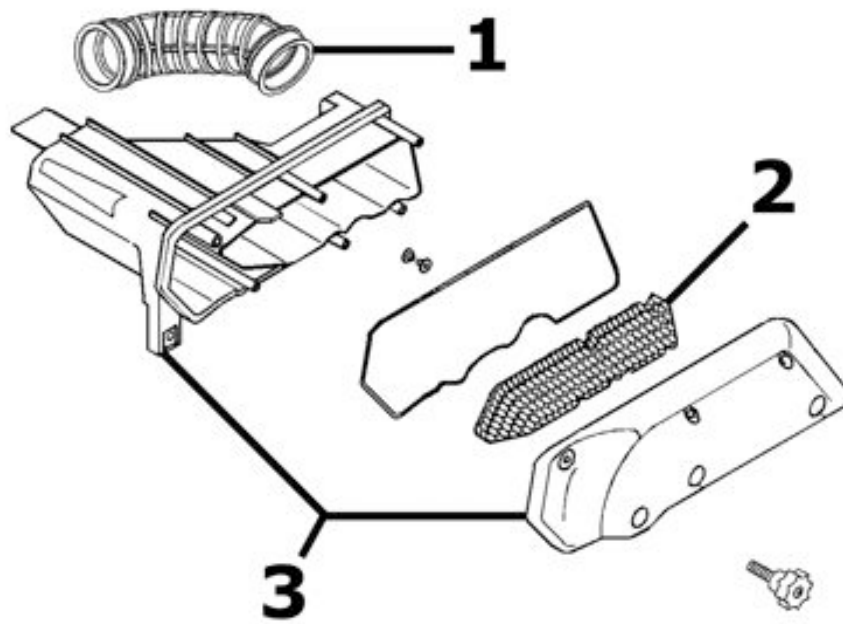

**AIR FILTER**

	<b>Code</b>	<b>Action</b>	<b>Duration</b>
1	004122	Carburettor filter manifold - Replacement	
2	001014	Air Filter - Replacement/Cleaning	
3	001015	Air filter box - Replacement	

**Frame**

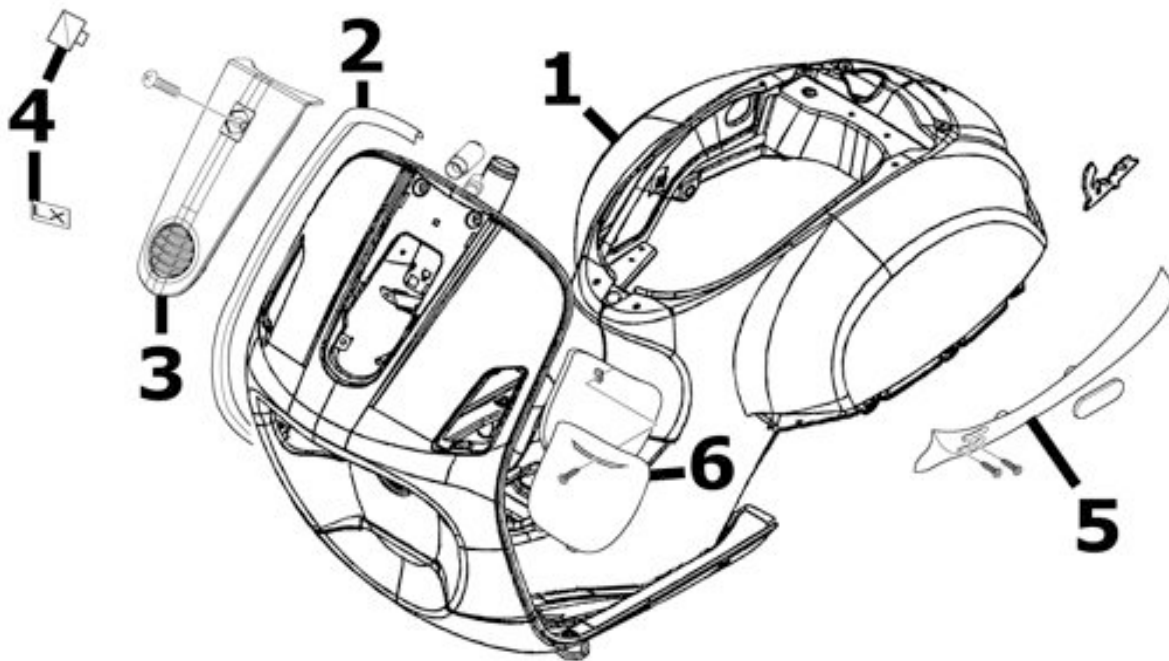
**CHASSIS**

	<b>Code</b>	<b>Action</b>	<b>Duration</b>
1	004001	Chassis - Replacement	
2	004023	Front shield beading - Replacement	
3	004149	Front shield cover - Replacement	
4	004159	Plates / Stickers - Replacement	
5	004012	Posterior flanks - Substitution	
6	004059	Spark plug inspection flap - Replacement	

**Centre-stand**

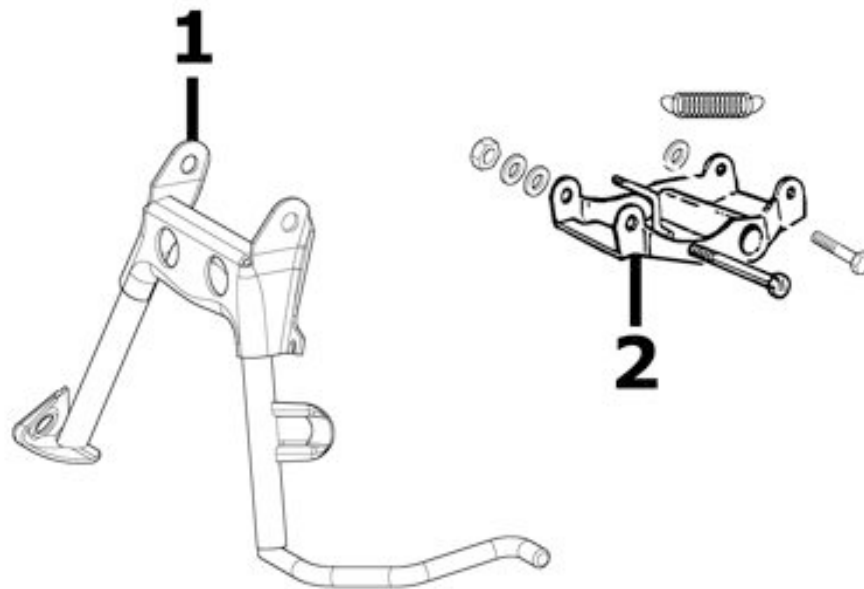

**STAND**

	Code	Action	Duration
1	004004	Stand - Replacement	
2	004171	Stand support plate - Replacement	

**Footrests**

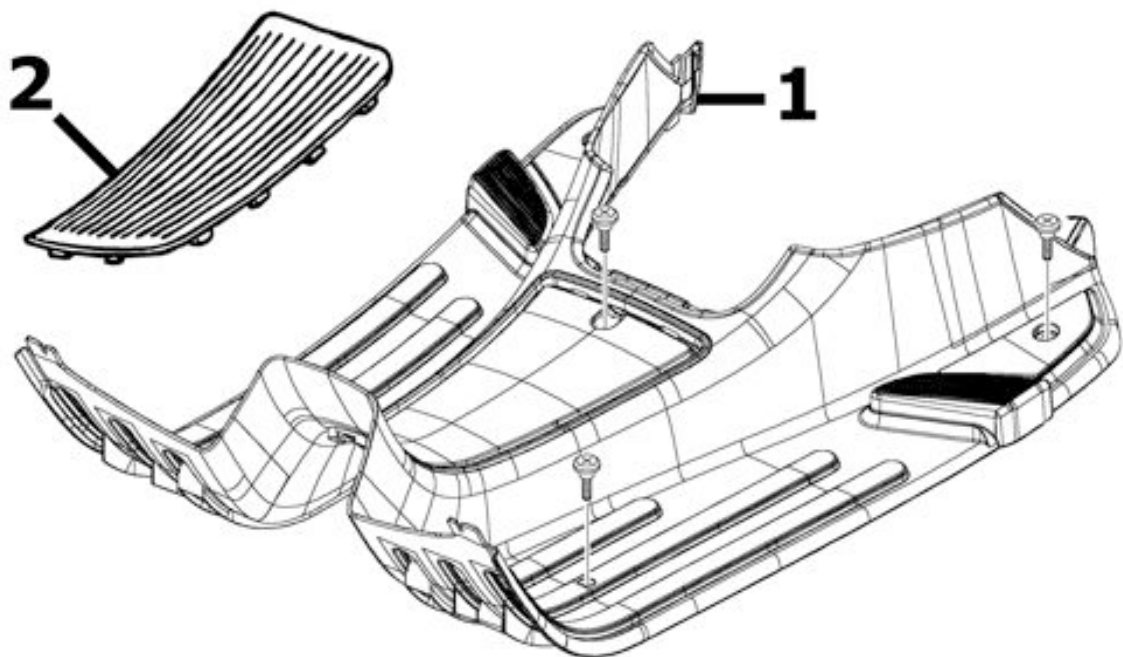

**FOOTREST**

	Code	Action	Duration
1	004178	Footrest - Replacement	
2	004078	Front/rear footboard rubber. - Replacement	

## Rear cover

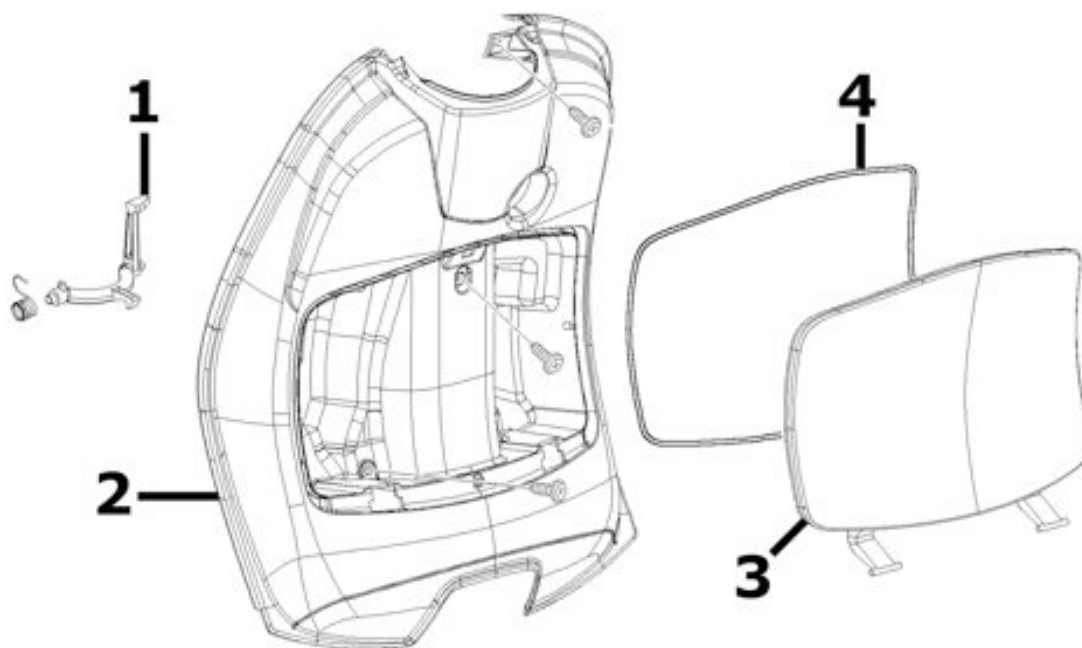

### KNEE-GUARD

	Code	Action	Duration
1	004174	Glove-box remote opening linkage - Replacement	
2	004065	Knee-guard - Removal and refitting	
3	004081	Glove compartment door - Replacement	
4	004082	Trunk gasket - Replacement	

## Underseat compartment

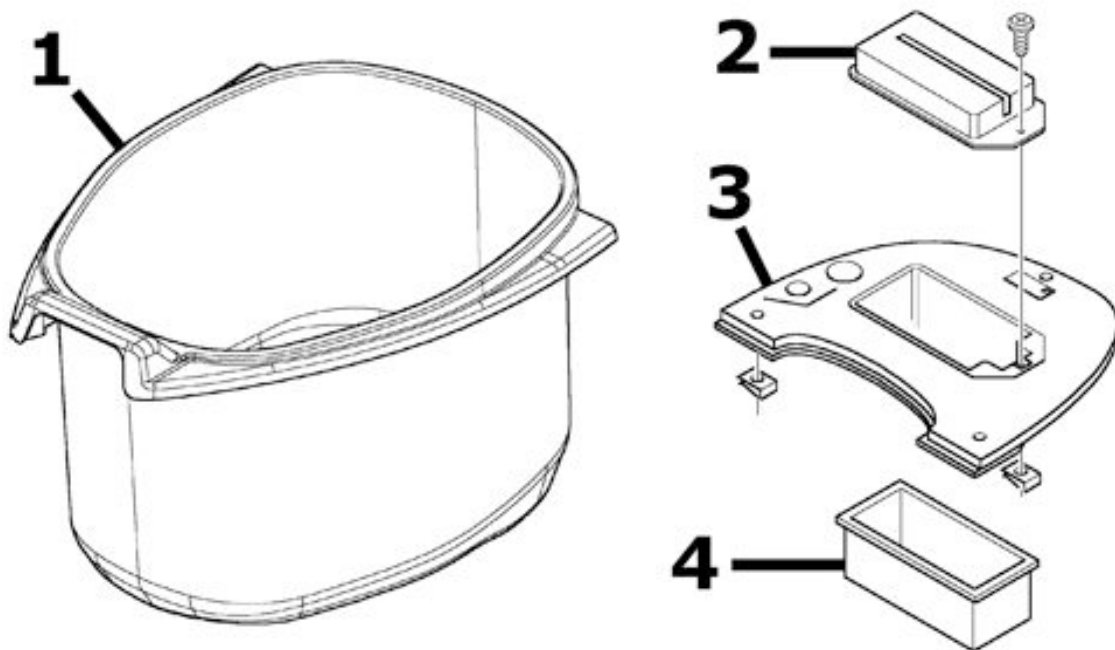
**UNDERSEAT**

	<b>Code</b>	<b>Action</b>	<b>Duration</b>
1	004016	Helmet compartment - Replacement	
2	005046	Battery cover - Replacement	
3	004011	Chassis central cover - Replacement	
4	004071	Battery compartment - Replacement	

**Plate holder**

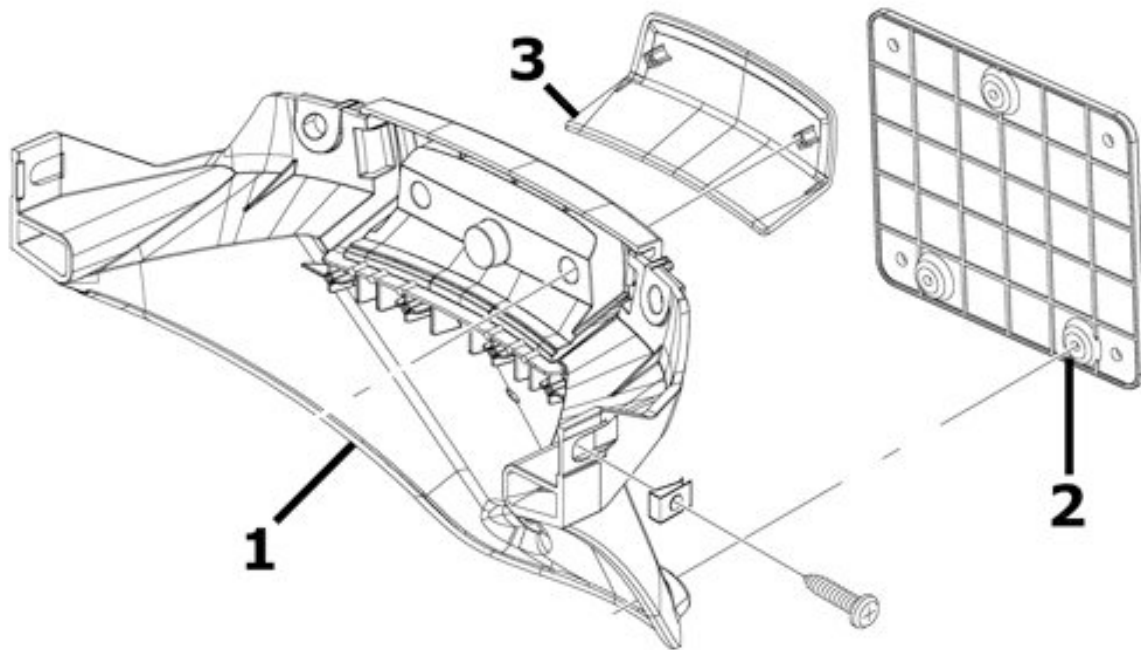

### SUPPORT PLATE

	Code	Action	Duration
1	004136	License plate holder - Replacement	
2	005048	Number plate holder - Replacement	
3	005032	Number plate light cover - Replacement	

### Mudguard



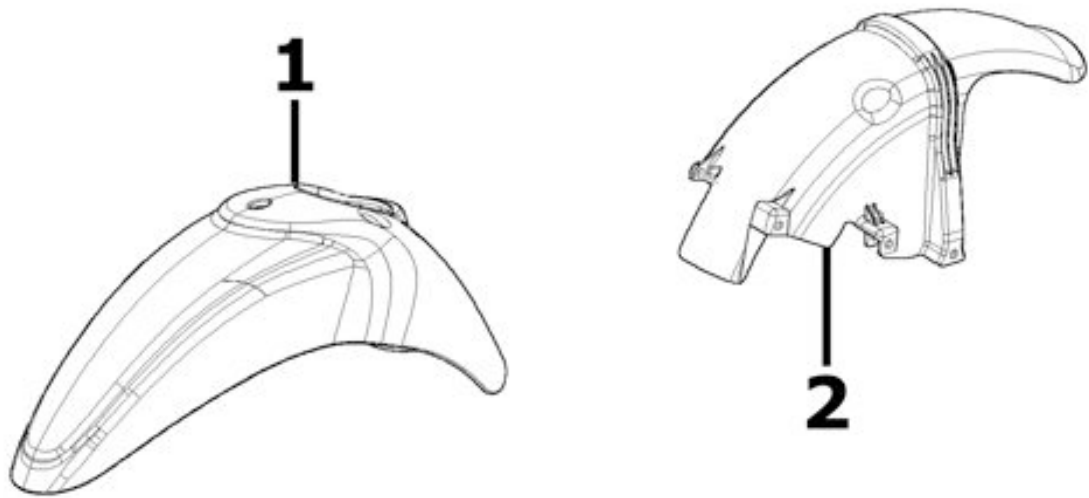

**MUDGUARDS**

	<b>Code</b>	<b>Action</b>	<b>Duration</b>
1	004002	Front mudguard - Replacement	
2	004009	Rear mudguard - Replacement	

**Fuel tank**

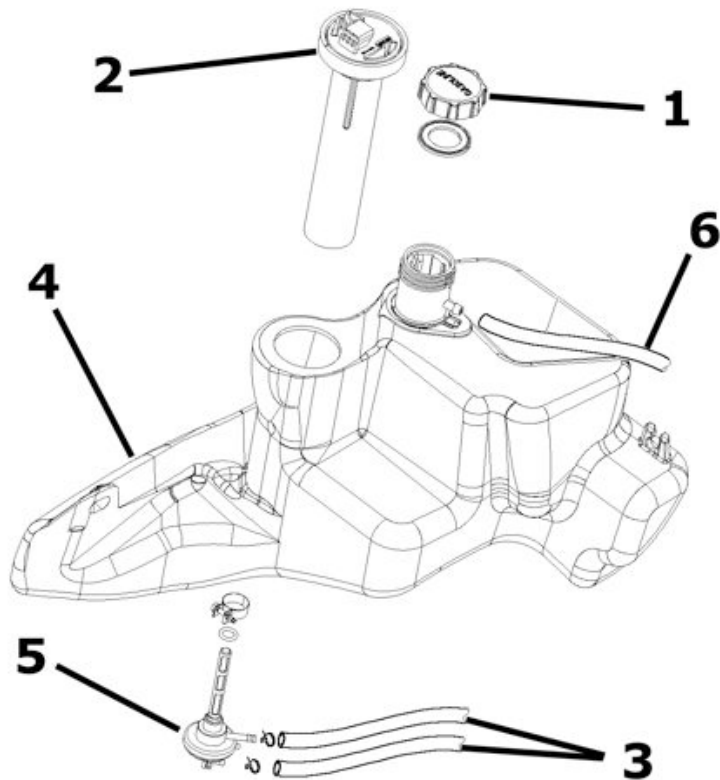

### FUEL TANK

	Code	Action	Duration
1	004168	Fuel filler cap - Replacement	
2	005010	Tank float - Replacement	
3	004112	Cock-carburettor pipe - Replacement	
4	004005	Fuel tank - Replacement	
5	004007	Mixture cock - Replacement	
6	004109	Fuel tank breather - Replacement	

### Rear shock-absorber

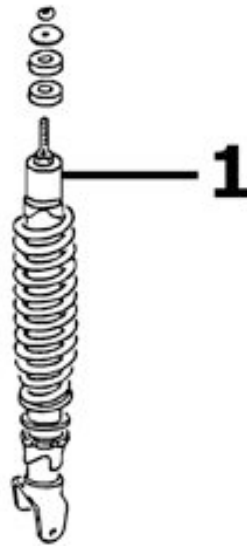

**REAR SHOCK ABSORBER**

	Code	Action	Duration
1	003007	Rear shock absorber - Disassembly and reassembly	

**Steering column bearings**

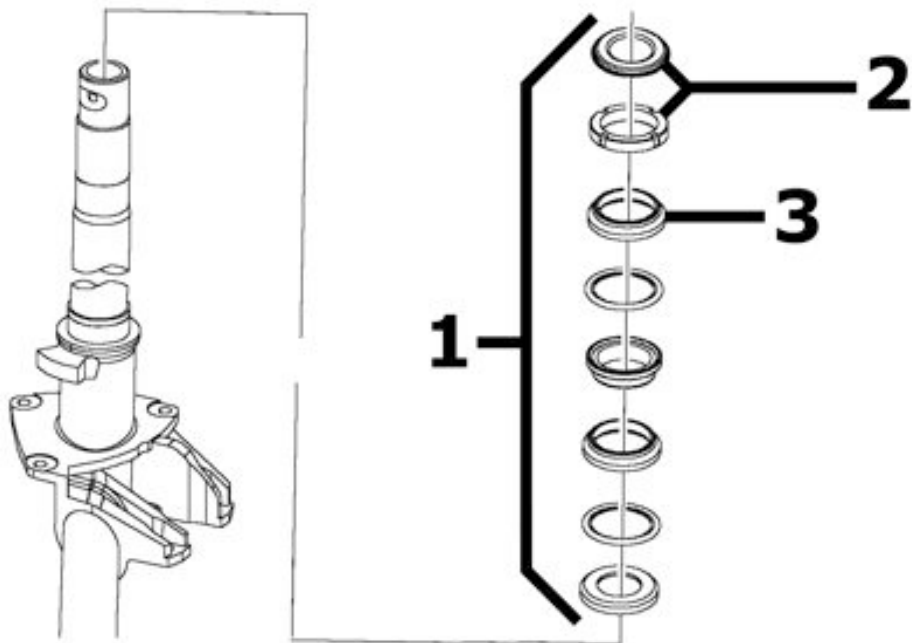

**STEERING COLUMN BEARINGS**

	Code	Action	Duration
1	003002	Steering fifth wheels - Replacement	
2	003073	Steering play - Adjustment	
3	004119	Bearing / Upper steering bearing - Replacement	

### Handlebar covers

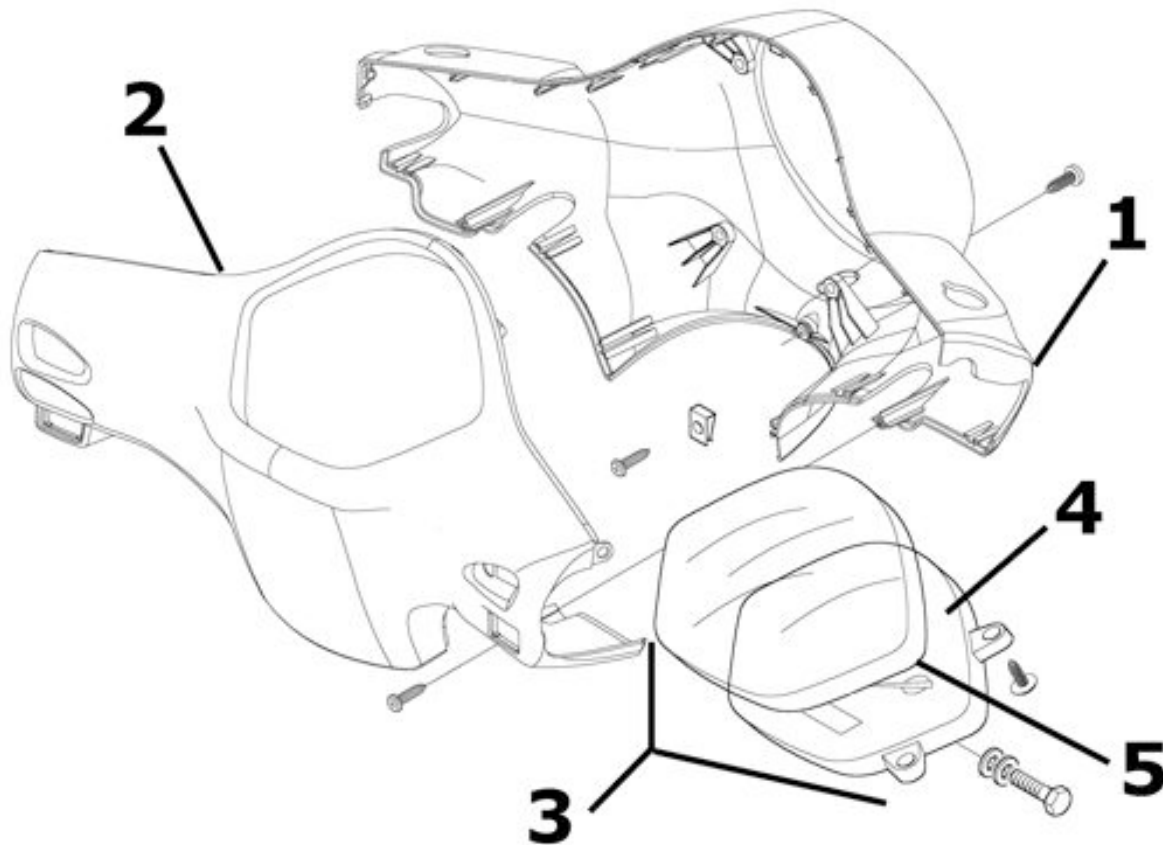

### SPEEDOMETER - HANDLEBAR COVERS

	Code	Action	Duration
1	004018	Handlebar front part - Replacement	
2	004019	Handlebar rear part - Replacement	
3	005054	Speedometer - Replacement	
4	005038	Dashboard warning lights - Replacement	
5	005078	Odometer plastic cover - Replacement	

**Handlebar components**

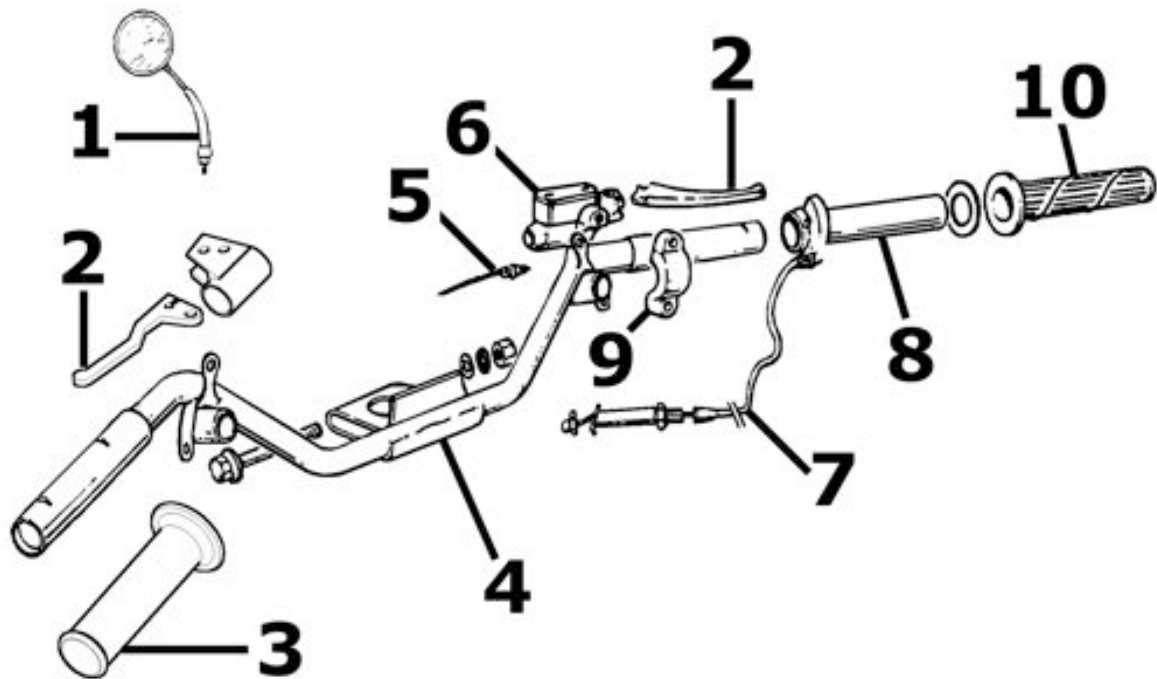

**HANDLEBAR COMPONENTS**

	<b>Code</b>	<b>Action</b>	<b>Duration</b>
1	004066	Rearview mirrors - Replacement	
2	002037	Complete gas control - Replacement	
3	002071	Left knob - Replacement	
4	003001	Handlebar - Removal and re-fitting	
5	005017	Stop light switch - Replacement	
6	002024	Brake pump - Removal and reinstallation	
7	002063	Gas control transmission - Replacement	
8	002060	Complete gas control - Replacement	
9	004162	Mirror U-bolt and/or brake pump fitting - Replacement	
10	002059	Right knob - Replacement	

**Swing-arm**

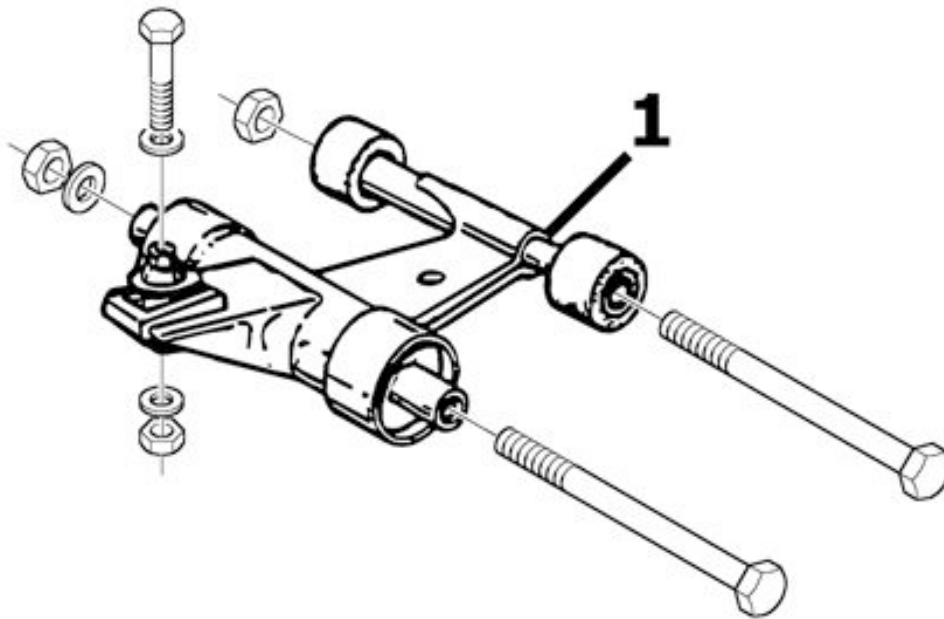

**SWINGING ARM**

	Code	Action	Duration
1	001072	Engine-frame connection swing arm - Replacement	

**Seat**

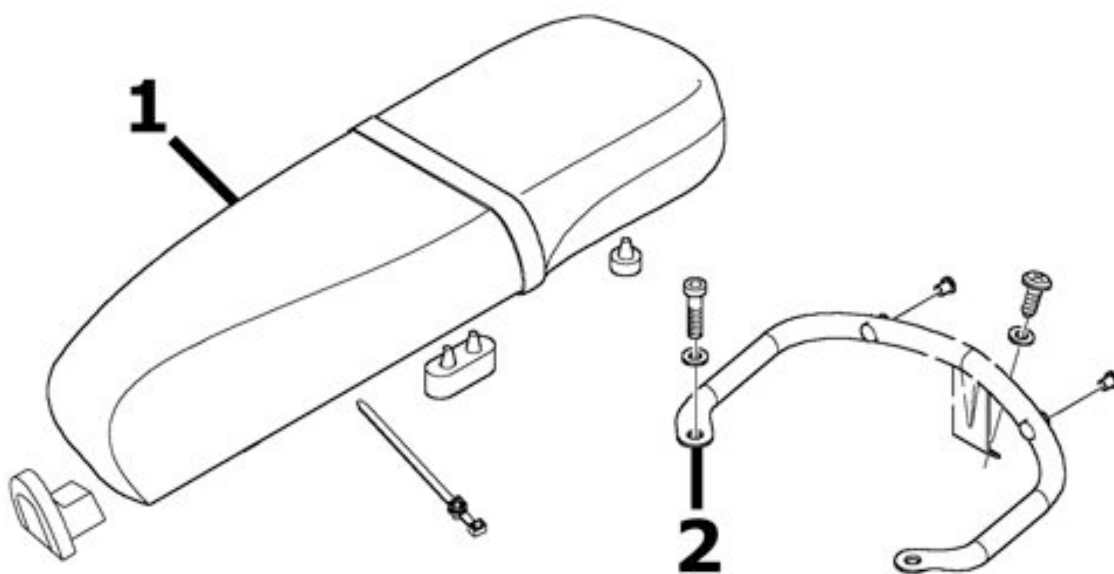

**SADDLE**

	Code	Action	Duration
1	004003	Saddle - Replacement	
2	004131	Rear rack mounting bracket - Replacement	

**Turn signal lights**

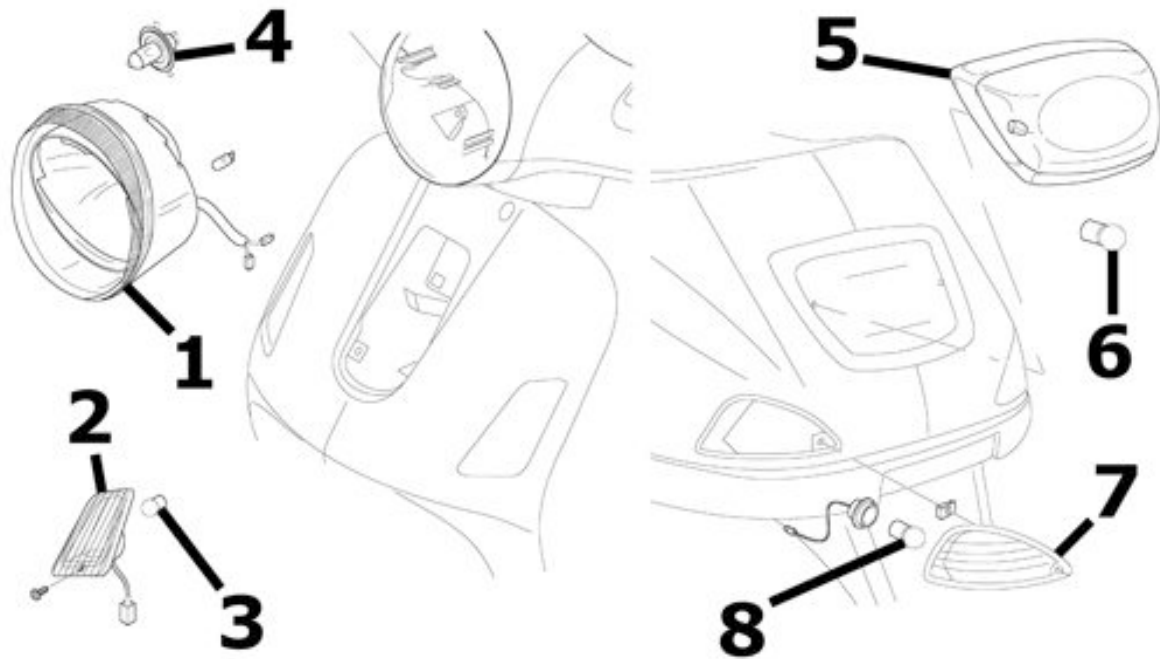

**TURN SIGNAL LIGHTS**

	Code	Action	Duration
1	005002	Headlight - Replacement	
2	005012	Front turn signal light - Replacement	
3	005067	Front direction indicator bulb - Replacement	
4	005008	Front headlights - Replacement	
5	005005	Rear light - Replacement	
6	005066	Rear light bulbs - Replacement	
7	005022	Rear turn signal light - Replacement	
8	005068	Rear turn indicator bulb - Replacement	

## Front wheel

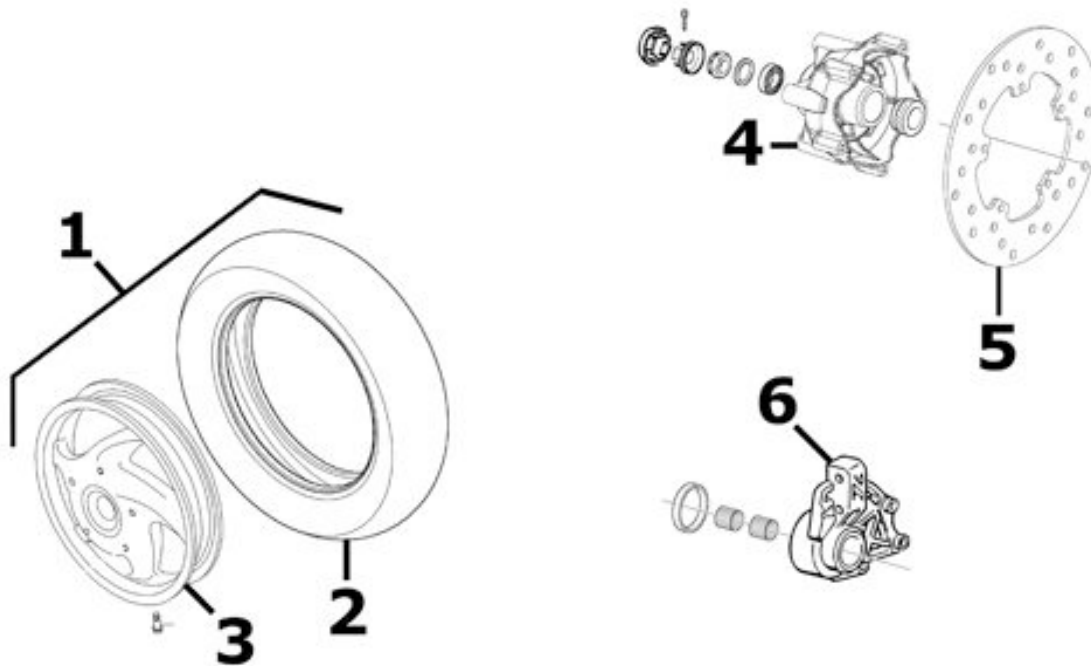

### FRONT WHEEL

	Code	Action	Duration
1	004123	Front wheel - Replacement	
2	003047	Front tyre - Replacement	
3	003037	Front wheel rim - Replacement	
4	003033	Front wheel hub - Replacement	
5	002041	Brake disc - Replacement	
6	003034	Front wheel hub bearings - Replacement	

## Rear wheel



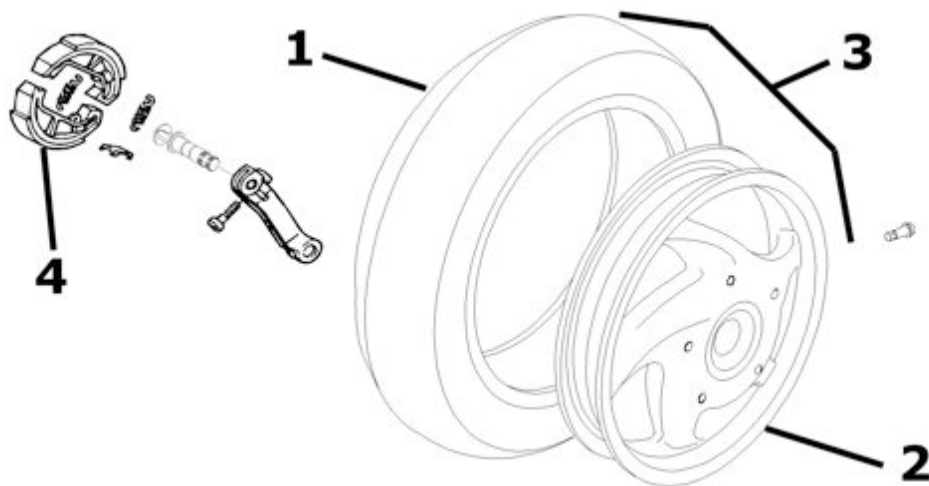

**REAR WHEEL**

	Code	Action	Duration
1	004126	Rear tyre - Replacement	
2	001071	Rear wheel rim - Removal and refitting	
3	001016	Rear wheel - Replacement	
4	002002	Rear brake shoes/pads - Replacement	

**Electric devices**

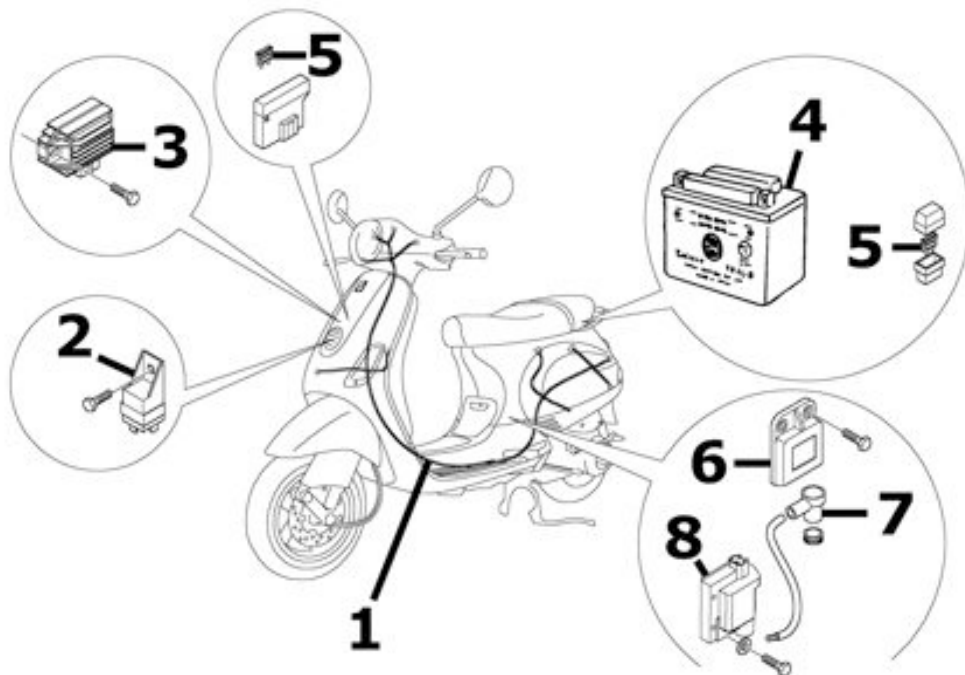

**ELECTRIC COMPONENTS**

	Code	Action	Duration
1	005001	Electric circuit - Replacement	
2	005011	Start-up remote control switch - Replacement	
3	005009	Voltage regulator - Replacement	
4	005007	Battery - Replacement	
5	005052	Fuse (1) - Replacement	
6	001023	Controller - Replacement	
7	001094	Spark plug cap - Replacement	
8	001069	H.T. coil - Replacement	

**Electronic controls**

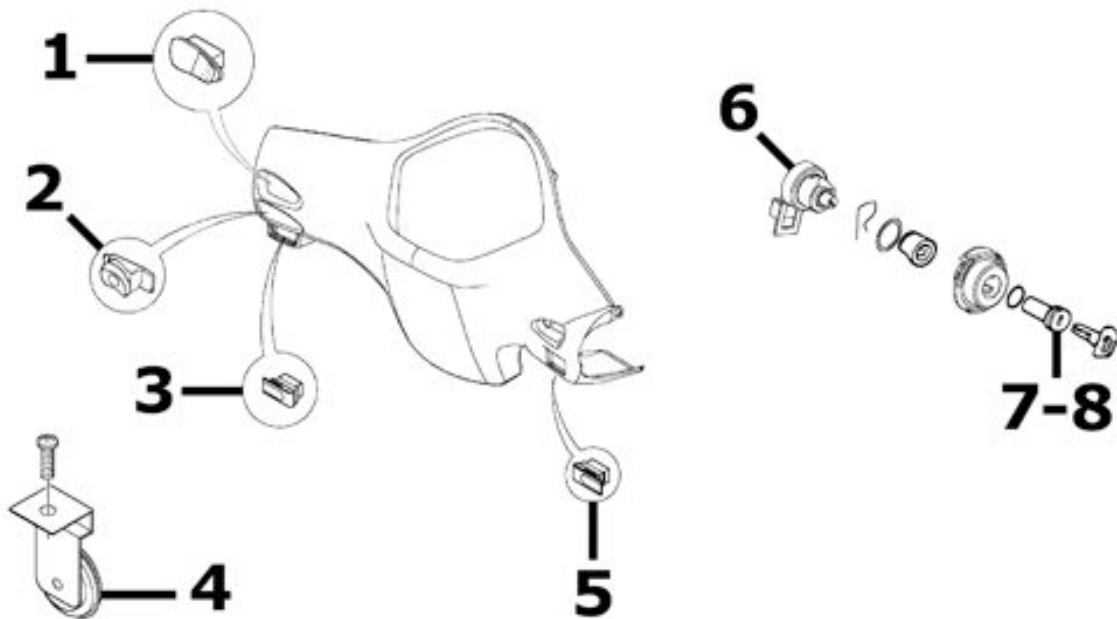

**ELECTRIC CONTROLS**

	Code	Action	Duration
1	005039	Light switch - Replacement	
2	005006	Lights or flashlights switch - Replacement	
3	005040	Horn button - Replacement	
4	005003	Electric horn - Replacement	
5	005041	Starter button - Replacement	
6	005016	Key switch - Replacement	

	Code	Action	Duration
7	004096	Locks series - Replacement	
8	004010	Antitheft lock - Replacement	

**Transmissions**

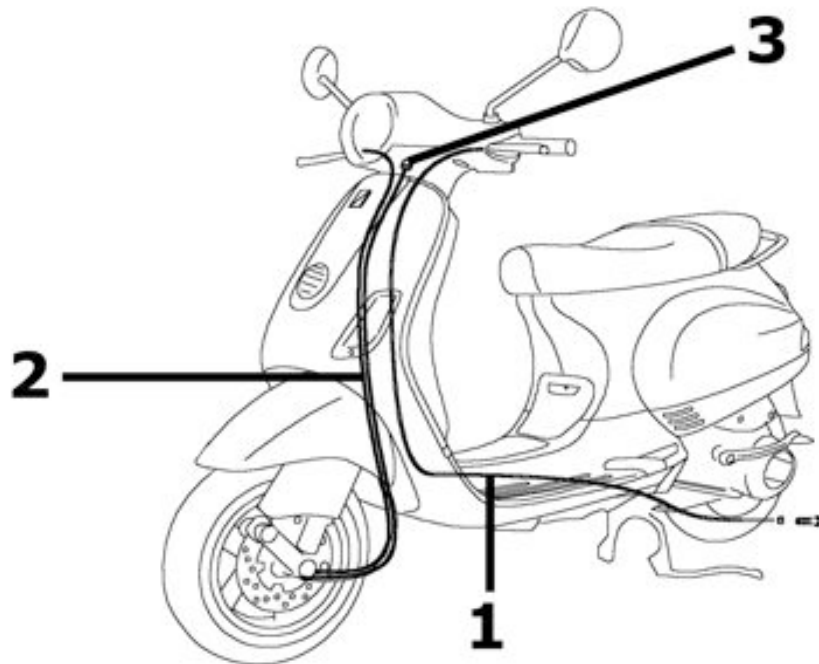

**TRANSMISSIONS**

	Code	Action	Duration
1	002053	Rear brake transmissions assembly - Replacement	
2	002051	Odometer transmissions assembly - Replacement	
3	002049	Odometer cable - Replacement	

**Front suspension**

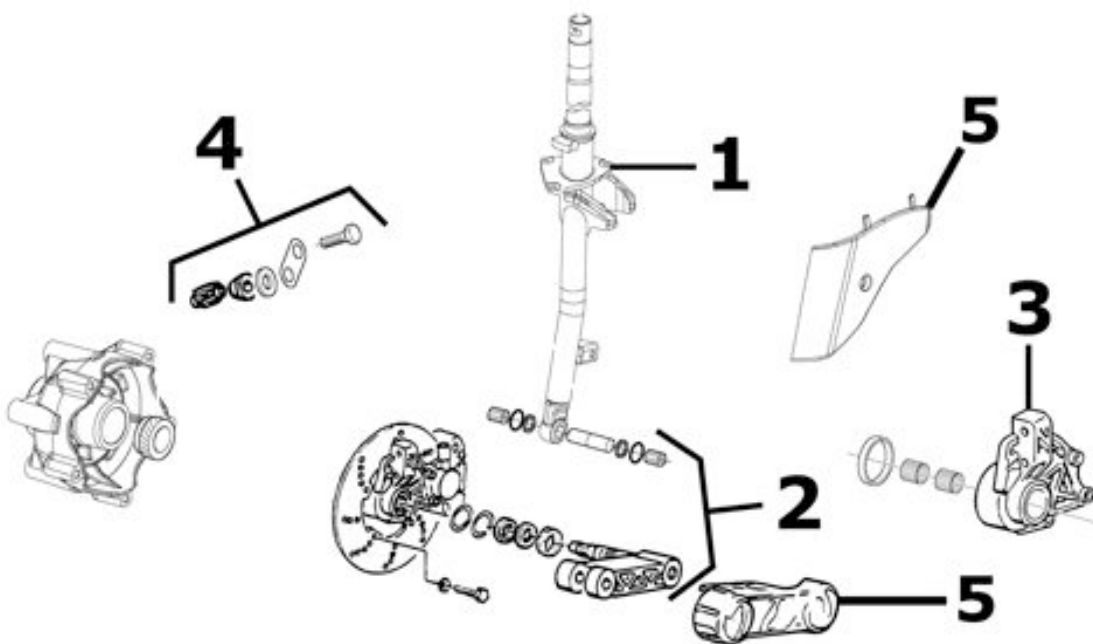

### FRONT SUSPENSION

	<b>Code</b>	<b>Action</b>	<b>Duration</b>
1	003045	Steering column - Replacement	
2	003010	Front suspension - - Revision	
3	003035	Shock abs. and brake caliper support - Replacement	
4	001064	Speedometer gear - Replacement	
5	003044	Shock absorber cover - Replacement	

### **Braking system**

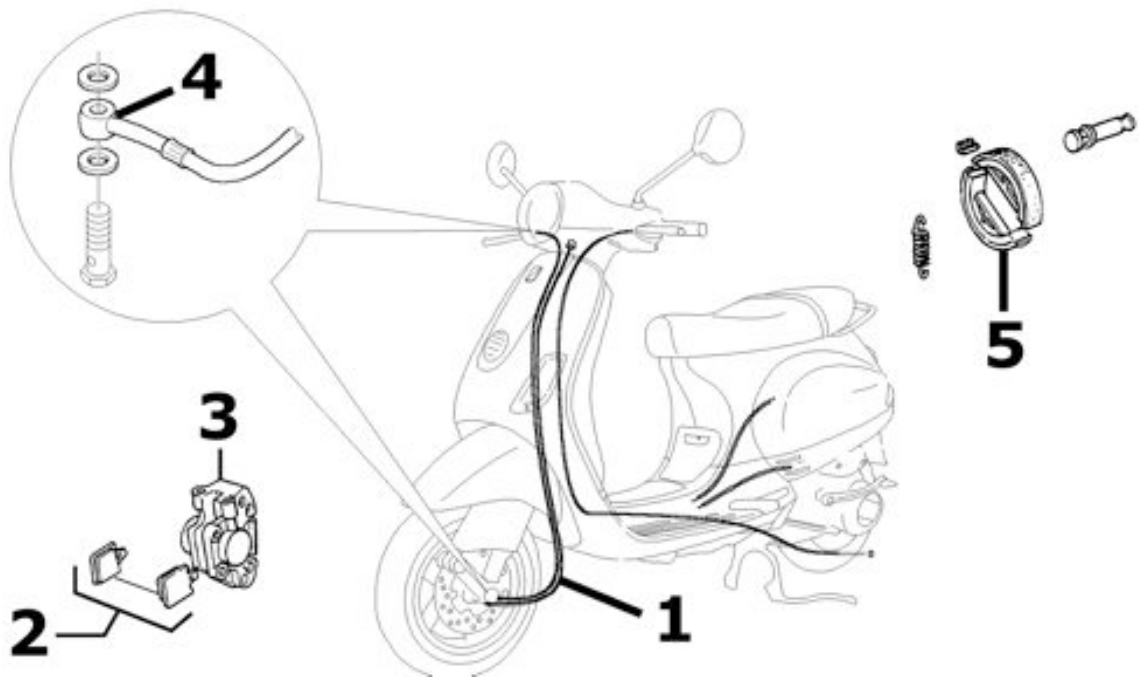

**BRAKING SYSTEM**

	<b>Code</b>	<b>Action</b>	<b>Duration</b>
1	002021	Front brake line - Replacement	
2	002007	Front brake shoes/pads - Removal and refitting	
3	002039	Front brake calliper - Removal and refitting	
4	002047	Front brake liquid and circuit bleeding - Replacement	
5	002002	Rear brake shoe - pad - Replacement	

**Secondary air box**

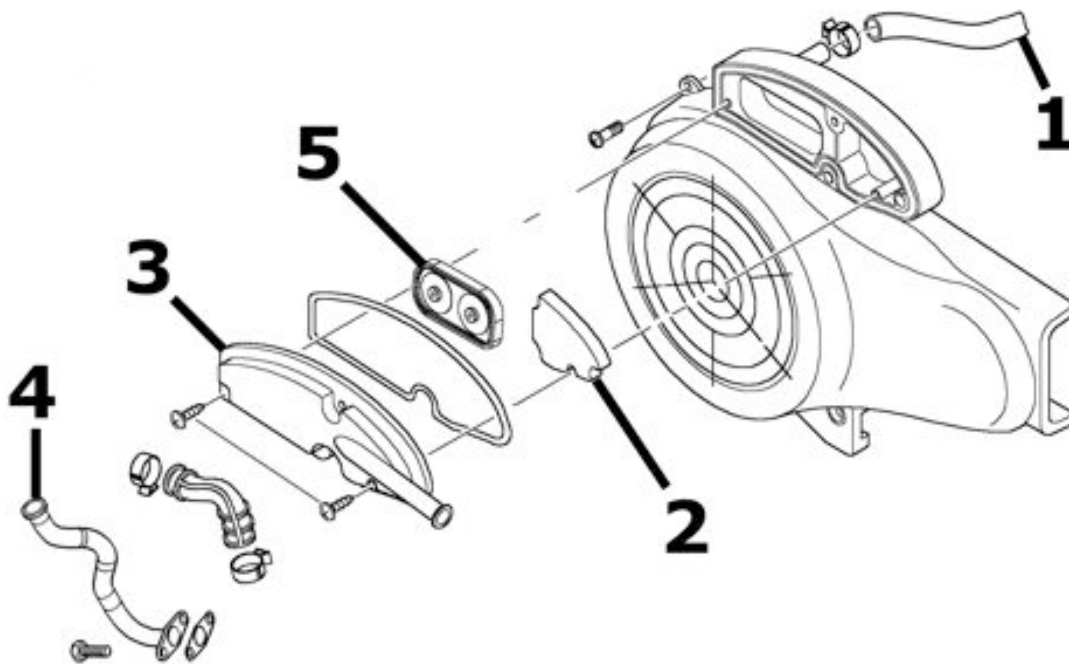

### SECONDARY AIR BOX

	<b>Code</b>	<b>Action</b>	<b>Duration</b>
1	001164	Crankcase secondary air junction - Replacement	
2	001161	Secondary air filter- Replacement / Cleaning	
3	001162	Secondary air box - Replacement	
4	001163	Exhaust secondary air junction - Replacement	
5	001165	Secondary air valve - Replacement	