

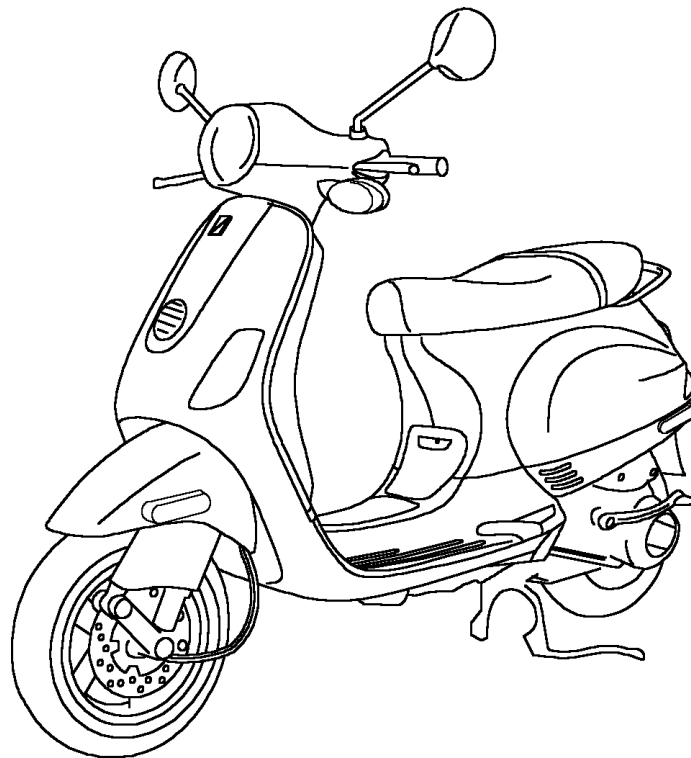

SILHOUETTE
SILHOUETTE
SILHOUETTE
SILHOUETTE
SILHOUETTE

ZAPC 386B..5



LX 50 4T

Mod. ZAPC 386B..5 000000

- 2005 -

(USA)

	AVVERTENZE NOTICE NOTICE ANMERKUNG ADVERTENCIAS	ZAPC 386B..5
--	--	---------------------

AVVERTENZE

- 1) Nel presente catalogo sono illustrati i particolari forniti come ricambi per i veicoli indicati in A1 a partire dai n° di telaio a fianco riportati.
- 2) Per la ricerca delle tavole vedere l'indice rappresentato in D1 e D2.
- 3) L'indice numerico dei particolari con le rispettive denominazioni è riportato da A2.
- 4) Per un corretto uso del Catalogo tener presente quanto segue:
 - L'intestazione della tavola riporta la denominazione del gruppo raffigurato e l'indicazione dei Mod. per i quali la tavola stessa è valida: eventuali tavole specifiche per il mercato Estero sono identificate anche dalla dicitura "Mercato Estero".

Nota bene - Consultare la tavola "Chiave di lettura" riportata in C1 a titolo di esempio.

NOTICE

- 1) En ce catalogue on a illustré les pièces livrées comme rechanges pour les véhicules indiqués en A1 à partir des n. de châssis indiqués à côté.
- 2) Pour la recherche des tables voir l'index donné en D1 et D2.
- 3) L'index numérique des pièces avec les dénominations respectives est donné à partir de A2.
- 4) Pour interpréter correctement le catalogue observer ce qui suit:
 - La tête de la table porte la dénomination du groupe illustré et l'indication des modèles pour lesquels la table même est valable: d'éventuelles tables spécifiques pour le marché étranger sont identifiées même par l'expression "Marché Etranger".

N.B. - Consulter la table "clé de lecture" donnée en C1 à titre d'exemple.

NOTICE

- 1) In this catalogue there are illustrated the parts supplied as spares for vehicles indicated in A1 starting from serial chassis numbers carried on the side.
- 2) For the consultation of the tables see the index in D1 and D2.
- 3) The numeric index of the pieces with the concerning part name is carried out starting from A2.
- 4) For a correct interpretation of the catalogue bear in mind what follows:
 - Table heading carries out part name of the illustrated unit and indication of models for which the table itself is valid: eventual specific tables for foreign market bear also the wording "Foreign Market".

N.B. - Consult the "reading key" carried out in C1 as an example.

ANMERKUNG

- 1) Im vorliegenden Katalog sind jene Teile wiedergegeben, welche als Ersatzteile der in A1 angeführten Fahrzeuge ab der seitlich angezeigten Rahmennummer geliefert werden.
- 2) Für das Auffinden der Tafeln siehe Inhaltsverzeichnis D1 und D2.
- 3) Das Nummernverzeichnis der Teile mit der entsprechenden Bezeichnung ist in A2 wiedergegeben.
- 4) Für den richtigen Gebrauch des Katalogs bitte folgendes beachten:
 - Die Aufschrift der Tafel gibt die Benennung der abgebildeten Gruppe und die Bestimmung des Modells wieder, für welche die Tafel gültig ist: eventuelle besondere Tafeln für den ausländischen Markt sind auch durch die Aufschrift "Ausländischer Markt" erkenntlich.

N.B. - Als Beispiel zur "Aufschlüsselung" dient die in C1 wiedergegebene Tafel.

ADVERTENCIAS

- 1) En este catálogo están ilustradas las piezas suministradas como repuestos para los vehículos indicados en A1 a partir de los números de chasis indicados al lado.
- 2) Para la consultación de las tablas ver el índice en D1 y D2.
- 3) El índice numérico de las piezas con las respectivas denominaciones empieza en A2.
- 4) Para una correcta interpretación del catálogo tener presente lo siguiente:
 - El título de las tablas indica la denominación del grupo ilustrado y la indicación de los modelos para los cuales la tabla misma es válida; en eventuales tablas específicas para el mercado extranjero figura también "Mercado exterior".

N.B. - Consultar la "Liave de lectura" indicada en C1 como ejemplo.

	AVVERTENZE NOTICE NOTICE ANMERKUNG ADVERTENCIAS	ZAPC 386B..5
---	--	---------------------

TABELLA ABBREVIAZIONI E SIMBOLI		TABLE ABBREVIATIONS ET SYMBOLES	TABLE OF ABBREVIATIONS AND SYMBOLS	TABELLE ABKÜRZUNGEN UND ZEICHEN	TABLA ABBREVIACIONES Y SIMBOLOS
FC1	Categoria 1	Catégorie 1	Category 1	Kategorie 1	Cat. 1
FC2	Categoria 2	Catégorie 2	Category 2	Kategorie 2	Cat. 2
FC3	Categoria 3	Catégorie 3	Category 3	Kategorie 3	Cat. 3
FC4	Categoria 4	Catégorie 4	Category 4	Kategorie 4	Cat. 4
ASP	Aspirazione	Admission	Intake	Ansaugung	Aspiración
SCA	Scarico	Vidange	Exhaust	Auspuff	Descarga
B	Colore Bianco	Coleur Blanc	White colour	Farbre Weiß	Color Blanco
G	Colore Giallo	Coleur Jaune	Yellow colour	Farbre Gelb	Color Amarillo
MR	Marrone	Brun	Brown	Braun	Marrón
N	Nero	Noir	Black	Schwarz	Negro
GRM	Grimeca	Grimeca	Grimeca	Grimeca	Grimeca
HT	Heng Tong	Heng Tong	Heng Tong	Heng Tong	Heng Tong
DX	Destro	Droit	R.H.	Rechte	Der.
SX	Sinistro	Gauche	L.H.	Linke	Izq.

TABELLA SIGLE E COLORI		TABLE SIGLES COLEURS	TABLE OF COLOUR ABBREVIATIONS	TABELLE KENNZEICHEN DER FARBEN	TABLA SIGLAS COLORES
79/A	Verniciato Nero 79/A	Vernis Noir 79/A	Black 79/A painted	Schwarz 79/A Gestrichen	Pintado Negro 79/A
146	Verniciato Prugna 146	Verni Prune 146	Prune 146 painted	Pflaume 146 lackiert	Pintado Ciruelo 146
525	Verniciato Bianco 525	Vernis blanc 525	White 525 painted	Weiß 525 Gestrichen	Pintado Blanco 525
738/A	Verniciato Grigio 738/A	Vernis Gris 738/A	Grey 738/A painted	Grau 738/A Gestrichen	Pintado Gris 738/A
894	Verniciato Rosso 894	Vernis Rouge 894	Red 894 painted	Rot 894 Gestrichen	Pintado Rojo 894



**CHIAVE DI LETTURA
CLE DI LECTURE
READING KEY-TABLE
TAFELERKÄRUNG
LLAVE DE LECTURA**

ZAPC 386B..5

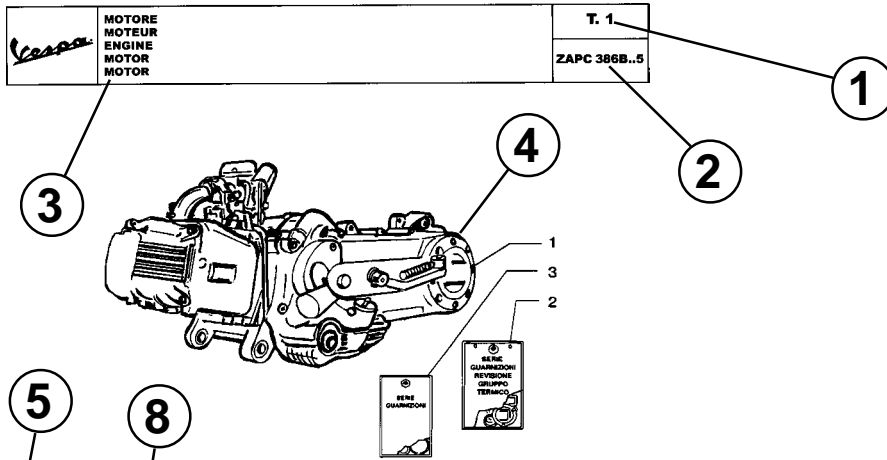

Pos. Loc. Pos.	Numero Number Número	Q.tà Qty M.ge Cart.	Nota Note Anm. Nota	Denominazione	Désignation	Description	Beschreibung	Descripción
1	8475125	1		Motore	Moteur	Engine	Motor	Motor
2	497036	1		Serie guarniz. gruppo termico	Set join. groupe thermique	Gask. set thermic unit	Dichtungssatz therm. Einheit	Juego de juntas term.
3	497037	1		Ser. guarn. e paraoli	Jeu bagues d'ét.	Oil seal and gask. set	Dicht. und Öl-schutz	Juego retenes

- 1) Numero di tavola: progressivo, serve ad identificare la tavola.
- 2) Codice modello.
- 3) Definizione dell'argomento trattato nella tavola.
- 4) Disegno esploso.
- 5) Numero di posizione: identifica il particolare dell'esploso di cui si indicano i dati caratteristici.
- 6) Numero di disegno del particolare richiesto.
- 7) Quantità.
- 8) Codice nota: (indicata solo quando necessaria).
- 9) Denominazione.

- 1) Numéro de table: progressif, il sert à identifier la table.
- 2) Code modèle.
- 3) Définition du sujet traité dans la table.
- 4) Vue éclatée.
- 5) Numéro de position: il identifie la pièce de la vue éclatée dont on indique les données caractéristiques.
- 6) Numéro de dessin de la pièce demandée.
- 7) Quantité.
- 8) Code note: (indiqué seulement si nécessaire).
- 9) Dénomination.

- 1) Table number: progressive, to identify the table.
- 2) Model code.
- 3) Definition of the issue in the table.
- 4) Exploded view.
- 5) Position number: identifier the part of the exploded view with specification.
- 6) Drawing number of the required part.
- 7) Quantity.
- 8) Note code: (it is shown only when it is necessary).
- 9) Denomination.

- 1) Tafelnummer: ansteigend, dient zur tafelfidentifizierung
- 2) Modellkennziffer
- 3) Beschreibung des Themas, das in der Tafel behandelt wird
- 4) Abbildung Explosionsbild
- 5) Positionsnummer: kennzeichnet das Einzelteil aus der Abbildung, von dem die technischen Daten angegeben werden.
- 6) Nummer der Abbildung des gewünschten Einzelteils
- 7) Menge.
- 8) Kennziffer Anmerkung: (nur wenn notwendig angegeben)
- 9) Bezeichnung

- 1) Número de tabla: progresivo, para identificar la tabla.
- 2) Código modelo.
- 3) Definición del asunto tratado en la tabla.
- 4) Dibujo desarrollado.
- 5) Número de posición: identifica la pieza del dibujo desarrollado de la cual se indican los datos característicos.
- 6) Número de dibujo de la pieza pedida.
- 7) Cantidad.
- 8) Código nota: (indicada sólo si necesaria).
- 9) Denominación.



INDICE PER LA RICERCA E CONSULTAZIONE DELLE TAVOLE
TABLES DES MATIERES POUR LA RECHER. ET LA CONSULT. DES TABLES
SUMMARY FOR THE SEARCH AND REFERENCE OF THE TABLES
ZUSAMMENFASSUNG FÜR DIE SUCHE UND KONSULTIERUNG DER TAFELN
INDICE PARA LA BUSCA Y CONSULTACION DE LAS TABLAS

ZAPC 386B..5

- T.1 PAG. 19** MOTORE - MOTEUR - ENGINE - MOTOR - MOTOR
- T.2 PAG. 20** CARTER - CARTER - CRANKASE - KURBELGEHÄUSE - CARTER
- T.3 PAG. 21** ALBERO MOTORE - VILEBREQUIN - CRANKSHAFT - KURBELWELLE - CIGÜENAL
- T.4 PAG. 22** GRUPPO CILINDRO-PISTONE-SPINOTTO - ENSEMBLE CYLINDRE-PISTON-AXE DE PISTON - CYLINDER-PISTON-WRIST PIN, ASSY - GRUPPE ZYLINDER-KOLBEN- KOLBENBOLZEN - GRUPO CILINDRO-PISTON-EJE DE PISTON
- T.5 PAG. 23** GR. TESTA-VALVOLE - ENSEMBLE CULASSE-SOUPAPES - CYLINDER HEAD-VALVES - EINHEIT KOPF-VENTIL - CULATA - VÁLVULAS
- T.6 PAG. 24** GRUPPO SUPPORTO BILANCIERI - ENSEMBLE SUPPORT BILANCIERS - ROCKER LEVERS SUPPORT - EINHEIT KIPPBEHÄLTER - SOPORTE BRAZO OSCILANTE
- T.7 PAG. 25** COPERCHIO TESTA - COUVERCLE CULASSE - CILINDER HEAD COVER - ZYLINDERKOPFABDECKUNG - TAPA CULATA
- T.8 PAG. 26** PULEGGIA CONDOTTA - POULIE ENTRAINEE - DRIVEN PULLEY - GETRIEBENE RIEMENSCHLEIBEN - POLEA CONDUCTIDA
- T.9 PAG. 27** PULEGGIA MOTRICE - POULIE MOTRICE - DRIVING PULLEY - TREIBENDE RIEMENSCHLEIBEN - POLEA MOTRIZ
- T.10 PAG. 28** MOTORINO AVVIAMENTO-LEVA AVVIAMENTO - DÉMARREUR ÉLECTRIQUE-LEVIER DE DEMARRAGE - STARTING MOTOR-STARTER LEVER - ANLASSERMOTOR-KICKSTARTER - MOTOR DE ARRANQUE-PALANCA DE ARRANQUE
- T.11 PAG. 29** POMPA OLIO-CARTER OLIO - POMPE D'HUILE-CARTER HUILE - OIL PUMP-OIL PAN - ÖLPUMPE-KURBELGEHÄUSE ÖL - BOMBA DE ACEITE-COLECTOR DE ACEITE
- T.12 PAG. 31** COPERCHIO TRASMISSIONE - COUVERCLE TRANSMISSION - TRANSMISSION COVER - ANTRIEBSDECKEL - TAPA DE LA TRANSMISIÓN
- T.13 PAG. 32** ASSE RUOTA POST. - ARBRE ROUE AR. - REAR WHEEL SHAFT - HINTERRAD ACHSE - EJE RUEDA TRASERA
- T.14 PAG. 33** VOLANO MAGNETE - VOLANT MAGNETIQUE - FLYWHEEL MAGNETO - LICHTMASCHINE - VOLANTE MAGNETICO
- T.15 PAG. 34** LEVA FRENO - LEVIER DU FREIN - BRAKE LEVER - BREMSHEBEL - PALANCA FRENO
- T.16 PAG. 35** CARBURATORE - CARBURATEUR - CARBURETTOR - VERGASER - CARBURADOR
- T.17 PAG. 36** CARBURATORE - CARBURATEUR - CARBURETTOR - VERGASER - CARBURADOR
- T.18 PAG. 38** DEPURATORE - FILTRE A AIR - AIR CLEANER - LUFTFILTER - FILTRO DE AIRE
- T.19 PAG. 39** SCATOLA ARIA SECONDARIA - BOITÎ AIR SECONDAIRE - SECONDARY AIR BOX - GEHÄUSE NEBENLUFT - CAJA AIRE SECUNDARIO
- T.20 PAG. 40** MARMITTA - SILENCIEUX - SILENCER - AUSPUFF - SILENCIADOR ESCAPE
- T.21 PAG. 41** CAVALLETTO-BRACCIO OSCILLANTE - BEQUILLE-BRAS OSCILLANT - CENTRAL STAND-SWINGING ARM - KIPPSTÄNDER-SCHWINGARM - CABALLETE-BRAZO OSCILANTE

	INDICE PER LA RICERCA E CONSULTAZIONE DELLE TAVOLE TABLES DES MATIERES POUR LA RECHER. ET LA CONSULT. DES TABLES SUMMARY FOR THE SEARCH AND REFERENCE OF THE TABLES ZUSAMMENFASSUNG FÜR DIE SUCHE UND KONSULTIERUNG DER TAFELN INDICE PARA LA BUSCA Y CONSULTACION DE LAS TABLAS	ZAPC 386B..5
--	---	---------------------

- T.22 PAG. 42** SCOCCA - COQUE - BODYWORK - KAROSSERIE - CARROCERÍA
- T.23 PAG. 46** PEDANA-TAPPETINI - MARCHEPIED-TAPIS - FOOT BOARD-RUBBER MATS - FUßRETT-FUßMATTE - ESTRIBO-ALFOMBRILLAS
- T.24 PAG. 47** BAULETTO ANTERIORE - COFFRE A L'AVANT - FRONT GLOVE GEPÄCKFACH - MALETA DELANTERA
- T.25 PAG. 49** SERBATOIO CARBURANTE - RESERVOIR - FUEL TANK - KRAFTSTOFFTANK - DEPOSITO CARBURANTE
- T.26 PAG. 50** PORTACASCO - PORTE CASQUE - CASE HELMET - SCHUTZHELMTRÄGER - PORTA CASCO
- T.27 PAG. 51** SELLA - SELLE - SADDLE - SATTEL - SILLIN
- T.28 PAG. 52** PARAFANGO ANT. E POST. - GARDE BOUE AV. ET AR. - FRONT AND REAR MUDGUARD VORDERKOTFLÜGEL-HINTERKOTFLÜGEL - GUARDABARROS DEL. Y TRAS.
- T.29 PAG. 53** STERZO-FRENO A DISCO - TUBE DE DIRECTION-FREIN À DISQUE - STEERING COLUMN-DISC BRAKE - STEUERROHR-SCHEIBENBREMSE - TUBO DE DIRECCION-FRENO DE DISCO
- T.30 PAG. 55** PINZA FRENO A DISCO - ETRIER FREIN A DISQUE - DISC BRAKE CALIPER - BREMSZANGE - PINZA FRENO DE DISCO
- T.31 PAG. 56** COPERTURA AMMORTIZZATORE ANTERIORE - COUVERTURE AMORTISSEUR AV. - FRONT DAMPER COVER - ABDECKUNG VORDERER STOßDAMPFER - CUBIERTA AMORTIGUADOR DELANTERO
- T.32 PAG. 57** AMMORTIZZATORE POSTERIORE - AMORTISSEUR AR. - REAR DAMPER - HINTERER STOßDAMPFER- AMORTIGUADOR TRASER
- T.33 PAG. 58** CONTACHILOMETRI-COPERCHI MANUBRIO - COMPTEUR KILOMETRIQUE-COUVERCLES DU GUIDON - SPEEDOMETER KMS.-HANDLEBAR COVERS - TACHOMETER-LENKERDECKEL - CUENTAKM.-TAPAS MANILLAR
- T.34 PAG. 60** COMPONENTI DEL MANUBRIO - PIECES COMPOSANT LE GUIDON - HANDLEBARS COMPONENT PARTS - LENKER BAUTEILE - PIEZAS QUE COMPONEN EL MANILLAR
- T.35 PAG. 61** COMPONENTI DEL MANUBRIO - PIECES COMPOSANT LE GUIDON - HANDLEBARS COMPONENT PARTS - LENKER BAUTEILE - PIEZAS QUE COMPONEN EL MANILLAR
- T.36 PAG. 62** TRASMISSIONI-TUBAZIONE FRENO - TRANSMISSIONS-TUYAU FREIN - TRANSMISSIONS-BRAKE PIPING - BOWDENZÜGE-BREMSSCHLAUCH - TRANSMISIONES - TUBO FRENO
- T.37 PAG. 63** FANALERIA ANTERIORE - FEUX AVANT - FRONT LIGHTS - VORDERBELEUCHTUNG - FAROS DELANTEROS
- T.38 PAG. 64** PROTEZIONE POSTERIORE - PROTECTION ARRIERE - REAR GUARD - HINTERE ABDECKUNG - PROTECCIÓN TRASEROS
- T.39 PAG. 65** FANALINO POSTERIORE - FEU AR. - REAR TAIL LAMP - HINTERRAD SCHLUßLEUCHTE - PILOTO
- T.40 PAG. 66** DISPOSITIVI ELETTRICI - DISPOSITIFS ELECTRIQUES - ELECTRICAL DEVICE - ELEKTRISCHE AUSRÜSTUNG - DISPOSITIVOS ELECTRICOS



INDICE PER LA RICERCA E CONSULTAZIONE DELLE TAVOLE
TABLES DES MATIERES POUR LA RECHER. ET LA CONSULT. DES TABLES
SUMMARY FOR THE SEARCH AND REFERENCE OF THE TABLES
ZUSAMMENFASSUNG FÜR DIE SUCHE UND KONSULTIERUNG DER TAFELN
INDICE PARA LA BUSCA Y CONSULTACION DE LAS TABLAS

ZAPC 386B..5

- T.41 PAG. 67** DISPOSITIVI ELETTRICI - DISPOSITIFS ELECTRIQUES - ELECTRICAL DEVICE - ELEKTRISCHE AUSRÜSTUNG - DISPOSITIVOS ELECTRICOS
- T.42 PAG. 68** RUOTA ANTERIORE - ROUE AV. - FRONT WHEEL - VORDERRAD - RUEDA DELANTERA
- T.43 PAG. 69** RUOTA POSTERIORE - ROUE AR. - REAR WHEEL - HINTERRAD - RUEDA TRASERA
- T.44 PAG. 70** TARGHETTE - MONOGRAMMES - NAME PLATES - PLAKETTE - LETRERO

	INDICE ALFANUMERICO	ZAPC 386B..5
	INDEX ALPHANUMERIQUE	
	ALPHANUMERIC INDEX	
	NUMMERNVERZEICHNIS	
INDICE ALFANUMERICO		

Numero Numéro Number Nummer Número	N. Tavola Nr. Planche Drawing No. Zeichnung Nr. N. Tabla	Pos. Pos. Loc. Pos. Pos.	Numero Numéro Number Nummer Número	N. Tavola Nr. Planche Drawing No. Zeichnung Nr. N. Tabla	Pos. Pos. Loc. Pos. Pos.	Numero Numéro Number Nummer Número	N. Tavola Nr. Planche Drawing No. Zeichnung Nr. N. Tabla	Pos. Pos. Loc. Pos. Pos.
000267	14	7	020104	38	10	231215	37	3
000397	15	5	020108	31	16	232108	21	4
003056	18	8	021108	32	4	232108	21	8
003058	30	8	021114	29	5	232108	32	7
003751	29	30	021210	31	14	239388	12	10
006078	33	12	030115	21	14	239388	13	1
006416	10	11	031056	33	10	239388	2	3
006422	29	24	031058	30	12	239388	2	4
006624	8	3	031089	11	4	239388	4	1
006635	29	9	031091	10	1	239388	5	10
006647	13	4	031091	16	1	252420	24	13
006731	29	17	031091	7	12	253937	40	7
006965	37	6	031120	31	5	254485	18	2
006966	27	6	077023	29	28	254485	23	5
006966	29	14	077024	29	27	254485	24	9
008372	39	6	092517	29	7	254485	25	15
008432	22	10	119219	29	18	254485	26	4
008432	38	2	122781	21	1	254485	27	9
008457	33	7	123394	34	5	254485	28	4
008457	37	2	123394	35	9	254485	31	12
011109	29	29	127927	36	5	254485	38	8
012528	41	5	129953	39	5	257614	24	10
012533	18	5	145298	12	5	257617	24	11
012533	28	5	149104	31	9	258146	18	7
012535	31	3	174085	31	13	258146	33	1
012543	35	11	174088	31	15	258160	25	4
012789	29	8	174874	31	2	258403	40	13
012789	43	6	177408	29	21	259151	19	11
013763	38	9	177414	29	3	259349	22	22
013880	25	3	177436	30	5	259372	26	3
013880	27	10	177442	29	11	259577	7	2
013880	28	11	177443	29	12	259830	24	2
015330	35	7	177445	29	22	259830	27	4
015585	14	12	177451	29	19	259830	38	6
015715	37	5	177494	30	4	259832	25	2
015759	25	6	177521	29	23	261319	21	17
015792	42	5	177609	29	6	265249	34	2
015804	28	8	177610	29	10	265300	9	6
015856	14	2	178150	32	1	265451	36	4
015856	41	6	178790	21	2	266625	2	8
015900	28	9	178790	35	12	266724	15	8
015911	22	26	179640	36	6	266725	15	2
015996	39	7	181351	28	13	266841	30	13
016404	10	12	181746	37	7	267038	32	2
016404	38	3	182302	26	5	267818	29	2
016405	33	11	194423	43	5	267819	30	7
016406	25	5	196868	25	11	267823	2	7
016408	31	10	198513	29	16	267948	34	3
016408	32	3	199190	12	6	267958	12	3
018591	38	5	199190	22	20	267958	22	3
018640	18	6	199190	22	4	268158	32	5
018644	10	8	223605	35	1	268596	24	6



**INDICE ALFANUMERICO
INDEX ALPHANUMERIQUE
ALPHANUMERIC INDEX
NUMMERNVERZEICHNIS
INDICE ALFANUMERICO**

ZAPC 386B..5

Numero Numéro Number Nummer Número	N. Tavola Nr. Planche Drawing No. Zeichnung Nr. N. Tabla	Pos. Pos. Loc. Pos. Pos.
--	--	--------------------------------------

Numero Numéro Number Nummer Número	N. Tavola Nr. Planche Drawing No. Zeichnung Nr. N. Tabla	Pos. Pos. Loc. Pos. Pos.
--	--	--------------------------------------

Numero Numéro Number Nummer Número	N. Tavola Nr. Planche Drawing No. Zeichnung Nr. N. Tabla	Pos. Pos. Loc. Pos. Pos.
--	--	--------------------------------------

269118	30	10	297275	24	5	479561	9	13
269755	15	9	297498	22	27	4795935	13	10
270310	36	3	297582	20	2	479866	9	3
270793	33	2	298548	12	4	479986	11	27
270793	33	8	298581	40	15	480066	13	14
270793	7	7	298604	22	9	4802185	13	6
270991	42	4	298729	27	5	480227	9	8
270991	43	8	298731	40	8	480230	9	10
271147	29	13	298838	40	4	480953	13	8
271779	21	15	298903	40	10	482291	12	13
271891	23	6	299047	26	10	482766	8	6
272836	27	11	299236	23	1	483443	8	10
273099	43	3	299557	22	13	483537	9	5
273419	15	6	299558	22	12	484123	11	11
2736235	15	1	299559	22	14	484123	11	25
273693	31	4	299964	22	7	484123	14	1
273754	21	11	299965	22	7	484123	6	4
274245	15	3	319242	5	9	484819	6	6
274489	35	4	319538	27	3	486081	2	5
274491	35	4	414834	13	2	4874805	13	12
285536	14	9	414837	10	9	4874855	13	11
285846	5	1	414837	11	13	487824	11	30
287913	11	14	430264	7	10	487935	8	12
2879633	11	22	430535	11	20	494097	30	2
288245	28	1	431242	14	10	494097	30	2
288474	14	6	431860	12	11	494511	27	8
288548	14	8	431860	2	6	497036	1	2
288639	13	7	433477	11	7	497037	1	3
289005	14	3	433800	20	5	497038	17	7
289420	5	5	433987	10	10	497398	33	5
289495	10	6	434345	11	23	56002R	29	25
289519	8	1	434447	11	15	56003R	29	26
289519	9	4	434541	40	11	560045	21	3
289731	12	8	434541	41	14	560284	29	1
289840	8	9	434735	13	5	5602865	30	6
289931	9	7	434943	6	9	560565	21	10
289933	8	15	435251	12	1	560661	43	7
289950	8	8	435295	12	14	56140R5	29	15
289952	8	4	436438	5	4	561433	29	4
289955	8	14	436695	11	8	56204R	21	9
290404	41	15	436751	11	17	56222R	31	1
290405	26	8	463195	22	23	562919	28	10
290860	41	9	478028	8	11	562923	35	10
292022	37	4	478197	13	13	563246	30	3
292022	38	13	478247	11	1	563728	43	4
292507	41	9	4783245	11	29	563984	21	7
292893	41	12	478498	13	3	564053	30	14
293256	41	9	478533	19	9	564257	29	27
294723	40	2	478761	20	9	564260	29	28
294877	40	1	478895	2	9	564683	34	6
295528	24	12	479132	18	11	573057	24	7
296456	27	12	4795526	8	5	57328R	34	1

	INDICE ALFANUMERICO	ZAPC 386B..5
	INDEX ALPHANUMERIQUE	
	ALPHANUMERIC INDEX	
	NUMMERNVERZEICHNIS	
INDICE ALFANUMERICO		

Numero Numéro Number Nummer Número	N. Tavola Nr. Planche Drawing No. Zeichnung Nr. N. Tabla	Pos. Pos. Loc. Pos. Pos.	Numero Numéro Number Nummer Número	N. Tavola Nr. Planche Drawing No. Zeichnung Nr. N. Tabla	Pos. Pos. Loc. Pos. Pos.	Numero Numéro Number Nummer Número	N. Tavola Nr. Planche Drawing No. Zeichnung Nr. N. Tabla	Pos. Pos. Loc. Pos. Pos.
573905	40	12	60041640ND	31	7	62213650F3	22	25
575079	28	3	60041640R7	31	7	62213650ND	22	25
575249	24	3	600488	32	6	62213650R7	22	25
575249	24	8	6011825	29	20	622139	23	7
575249	28	6	601610	31	11	62217950BM	24	1
575249	28	7	601618	36	1	62217950F2	24	1
575249	31	8	601716	35	5	62217950F3	24	1
575249	38	7	620529	22	19	62217950ND	24	1
575321	25	12	620556	22	15	62217950R7	24	1
576017	26	11	62211150BM	22	1	622187	22	6
576189	23	2	62211150F2	22	1	622188	22	6
576189	26	6	62211150F3	22	1	62218940BM	33	3
576267	12	2	62211150ND	22	1	62218940F2	33	3
576464	22	5	62211150R7	22	1	62218940F3	33	3
576702	44	1	62211550BM	24	4	62218940ND	33	3
576704	44	2	62211550F2	24	4	62218940R7	33	3
576707	44	6	62211550F3	24	4	62219040BM	33	4
576708	44	4	62211550ND	24	4	62219040D9	33	4
576953	44	3	62211550R7	24	4	62219040F2	33	4
577492	27	7	62212340BM	38	1	62219040F3	33	4
577557	25	13	62212340F2	38	1	62219040ND	33	4
58025R	41	13	62212340F3	38	1	62219040R7	33	4
580621	40	14	62212340ND	38	1	6221935	34	4
580653	41	11	62212340R7	38	1	622834	25	14
582060	21	13	62212440BM	23	4	62290750BM	22	2
582298	21	16	62212440F2	23	4	62290750F2	22	2
582504	21	6	62212440F3	23	4	62290750F3	22	2
582505	21	12	62212440ND	23	4	62290750ND	22	2
582619	16	6	62212440R7	23	4	62290750R7	22	2
583575	34	7	62212740BM	22	17	623020	26	2
583575	35	8	62212740F2	22	17	623572	27	2
584083	28	14	62212740F3	22	17	623705	44	5
584084	28	14	62212740ND	22	17	635101	43	2
584332	39	2	62212740R7	22	17	63881040BM	38	11
584521	41	3	62212840BM	22	17	63881040F2	38	11
584599	40	6	62212840F2	22	17	63881040F3	38	11
584810	41	2	62212840F3	22	17	63881040ND	38	11
584884	38	4	62212840ND	22	17	63881040R7	38	11
584925	22	24	62212840R7	22	17	638853	7	13
584926	22	24	62212940BM	22	18	638975	40	5
597150	30	9	62212940F2	22	18	638976	40	3
599986	42	1	62212940F3	22	18	638993	14	5
599990	42	2	62212940ND	22	18	638994	14	4
600067	43	1	62212940R7	22	18	639069	41	8
60041540BM	28	2	62213040BM	22	18	639280	37	8
60041540F2	28	2	62213040F2	22	18	639281	39	3
60041540F3	28	2	62213040F3	22	18	639285	39	1
60041540ND	28	2	62213040ND	22	18	639286	39	1
60041540R7	28	2	62213040R7	22	18	639292	33	6
60041640BM	31	7	622131	26	1	639296	37	9
60041640F2	31	7	62213650BM	22	25	639297	37	9
60041640F3	31	7	62213650F2	22	25	639302	41	1



**INDICE ALFANUMERICO
INDEX ALPHANUMERIQUE
ALPHANUMERIC INDEX
NUMMERNVERZEICHNIS
INDICE ALFANUMERICO**

ZAPC 386B..5

Numero Numéro Number Nummer Número	N. Tavola Nr. Planche Drawing No. Zeichnung Nr. N. Tabla	Pos. Pos. Loc. Pos. Pos.
--	--	--------------------------------------

Numero Numéro Number Nummer Número	N. Tavola Nr. Planche Drawing No. Zeichnung Nr. N. Tabla	Pos. Pos. Loc. Pos. Pos.
--	--	--------------------------------------

Numero Numéro Number Nummer Número	N. Tavola Nr. Planche Drawing No. Zeichnung Nr. N. Tabla	Pos. Pos. Loc. Pos. Pos.
--	--	--------------------------------------

639335	38	12	833722	11	9	969315	6	3
646833	35	3	833722	19	12	969319	11	5
646893	36	2	833722	41	4	969334	7	15
709037	21	5	833722	6	2	969339	7	1
709047	30	11	833788	15	7	96933R	11	18
709047	42	3	834254	11	24	969347	10	2
709532	16	3	841782	20	7	969348	41	16
709532	16	7	843194	18	3	969415	7	6
82521R	12	12	843195	18	4	969421	10	7
82645R	9	12	843213	20	8	969428	3	2
82650R	11	6	843525	19	7	969603	4	4
82655R	8	2	843567	19	10	9696045001	4	6
82671R	3	3	843684	6	5	9696045002	4	6
827085	14	14	844721	11	26	9696045003	4	6
82758R	19	8	844871	11	12	9696045004	4	6
827893	8	7	844888	11	21	969625	11	10
82798R	14	11	845465	20	4	969747	11	19
82817R	6	7	845489	16	5	969804	12	9
828339	41	7	845611	9	2	969877	11	3
828561	11	2	845765	5	8	969894	7	11
828583	20	6	845782	5	3	969918	7	4
828662	7	8	845946	16	2	CM001209	25	8
828822	17	19	8474875	2	1	CM001903	19	3
828824	17	12	8474885	20	1	CM001905	19	13
828825	17	3	8475125	1	1	CM002901	25	10
828830	17	17	847622	18	1	CM002904	25	7
828832	17	8	942135	13	9	CM002908	7	5
828833	17	16	969012	2	2	CM002910	18	9
828839	17	13	969028	2	10	CM006102	25	9
828840	17	6	969132	11	28	CM017405	22	11
828841	17	18	9692115	12	7	CM017405	39	4
828843	17	20	969213	4	3	CM017406	23	3
828844	17	10	969214	4	5	CM017406	37	1
828863	15	4	969215	4	7	CM017408	22	8
829337	41	10	969216	4	8	CM017408	26	9
830056	18	10	969217	4	9	CM017409	33	9
830212	9	1	96921R	10	3	CM017410	22	21
830286	14	13	969224	5	11	CM017410	26	7
831458	10	5	96922R	10	4	CM017410	28	12
832059	19	14	969230	4	2	CM02520100E8	27	1
832130	14	15	969236	5	12	CM02520100E9	27	1
832613	5	7	969238	5	6	CM025702	25	1
832614	5	7	969239	5	6	CM060968	35	6
832964	7	14	9692475	6	10	CM063804	34	8
832971	19	1	96925R	3	1	CM071802	40	9
832972	19	2	969265	6	12	CM074901	35	2
832973	19	4	969267	5	2	CM076101	30	1
833471	7	3	969268	6	13	CM100107	8	16
833472	19	5	9692695	6	8	CM1002025	8	13
833473	19	6	96926R	6	11	CM1102025	9	9
833494	20	3	969286	7	9	CM110301	9	11
833495	11	16	969315	6	1	CM141906	16	4



**INDICE ALFANUMERICO
INDEX ALPHANUMERIQUE
ALPHANUMERIC INDEX
NUMMERNVERZEICHNIS
INDICE ALFANUMERICO**

ZAPC 386B..5

Numero Numéro Number Nummer Número	N. Tavola Nr. Planche Drawing No. Zeichnung Nr. N. Tabla	Pos. Pos. Loc. Pos. Pos.
--	--	--------------------------------------

Numero Numéro Number Nummer Número	N. Tavola Nr. Planche Drawing No. Zeichnung Nr. N. Tabla	Pos. Pos. Loc. Pos. Pos.
--	--	--------------------------------------

Numero Numéro Number Nummer Número	N. Tavola Nr. Planche Drawing No. Zeichnung Nr. N. Tabla	Pos. Pos. Loc. Pos. Pos.
--	--	--------------------------------------

CM142102	17	2
CM142302	17	4
CM142402	17	15
CM142705	17	5
CM142805	17	9
CM142910	17	21
CM146601	17	11
CM147101	17	1
CM151704	17	14



**INDICE DELLE TAVOLE
INDEX ILLUSTRÉ
TABLE INDEX
TAFEL VERZEICHNIS
INDICE DE LAS TABLAS**

ZAPC 386B..5

TAV. 1

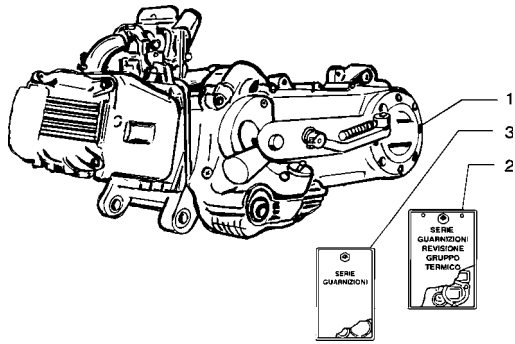

TAV. 2

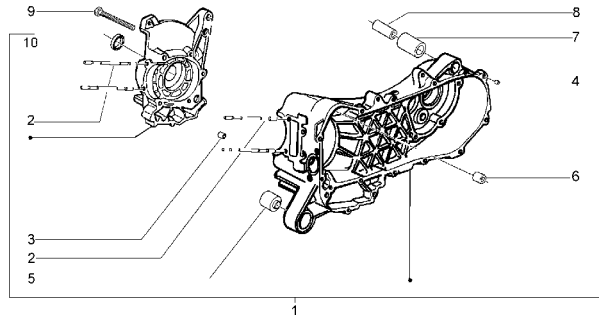

TAV. 3

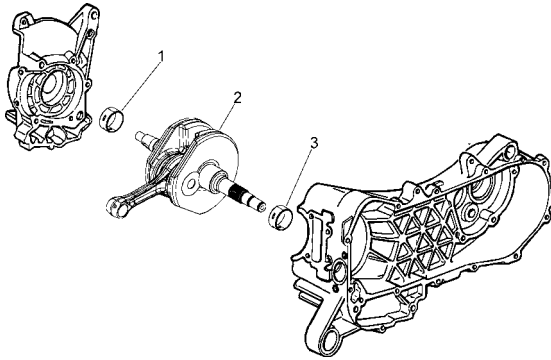

TAV. 4

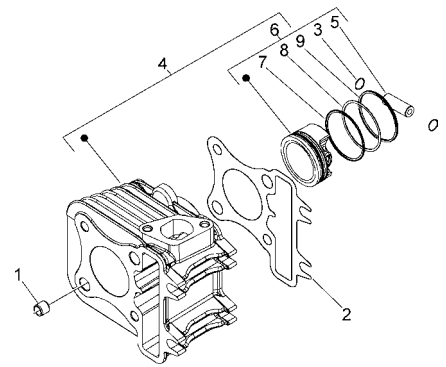

TAV. 5

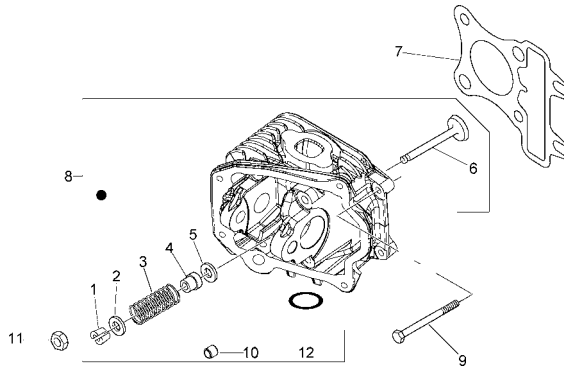

TAV. 6

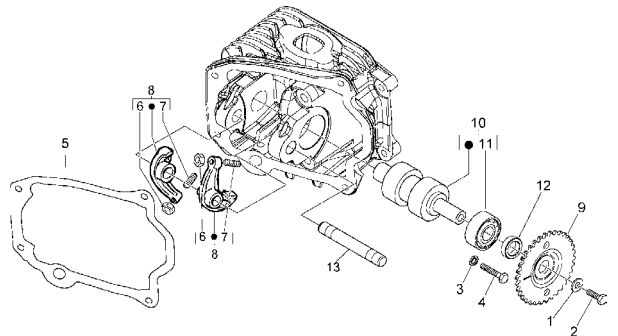

TAV. 7

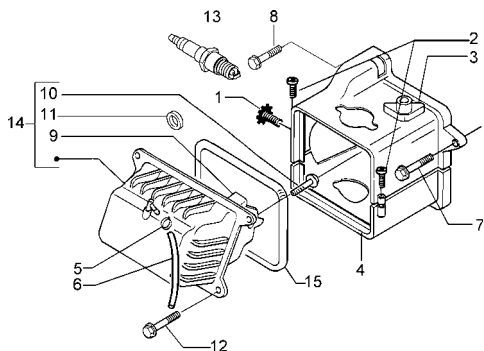

TAV. 8

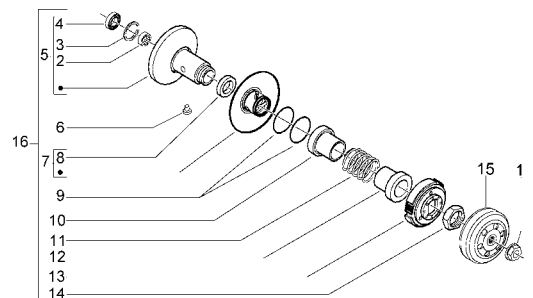

TAV. 9

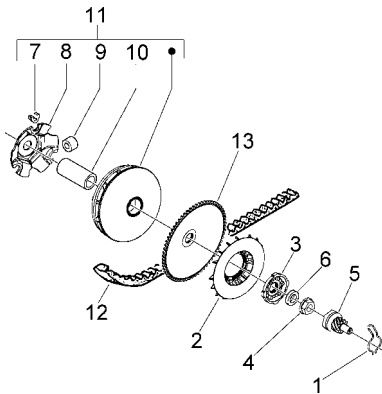

TAV. 10

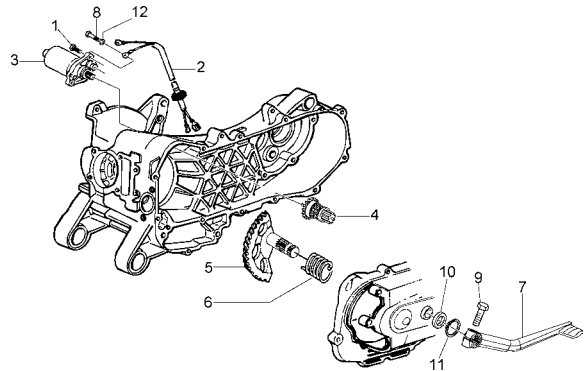

TAV. 11

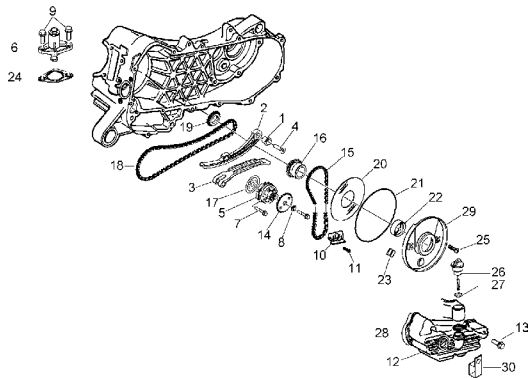

TAV. 12

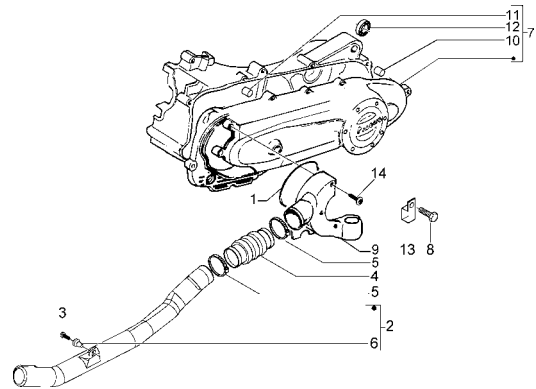

TAV. 13

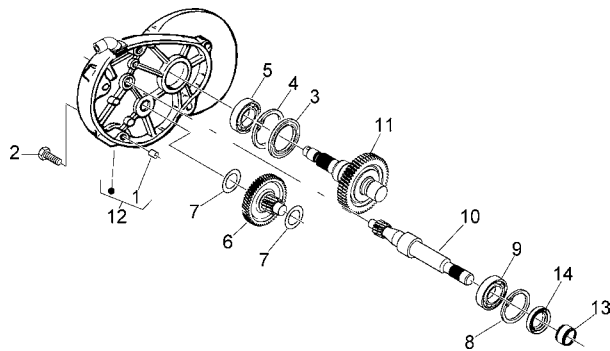

TAV. 14

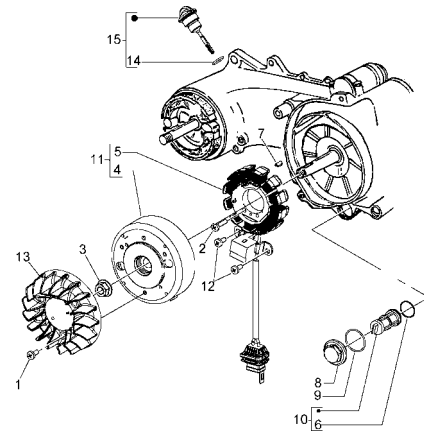

TAV. 15

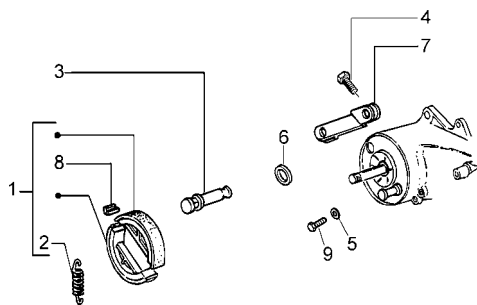

TAV. 16

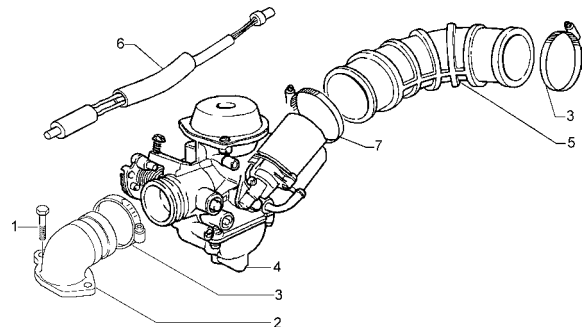

TAV. 25

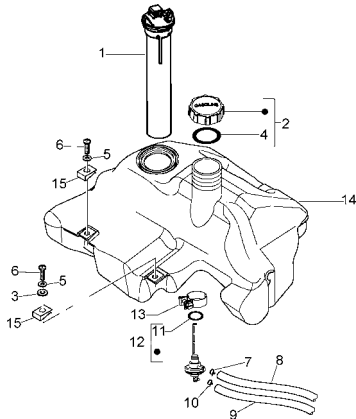

TAV. 26

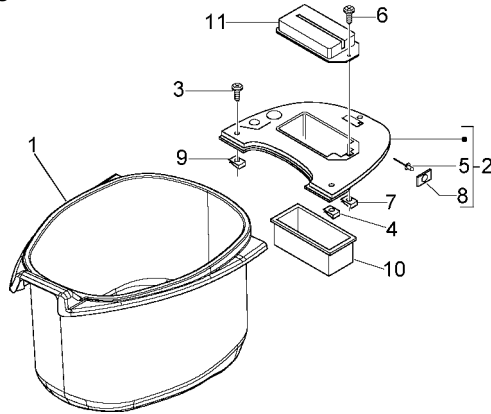

TAV. 27

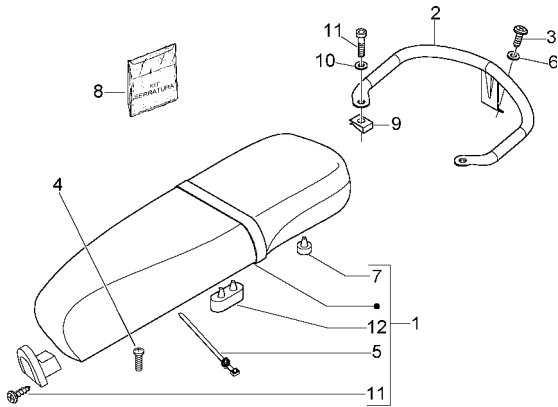

TAV. 28

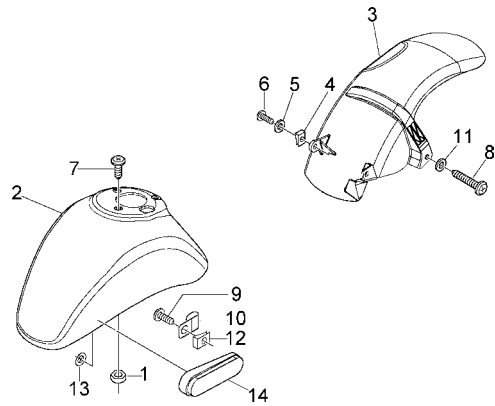

TAV. 29

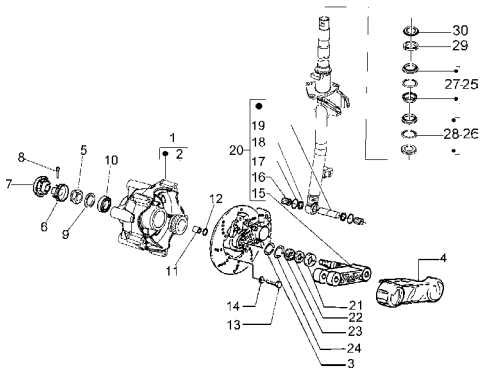

TAV. 30

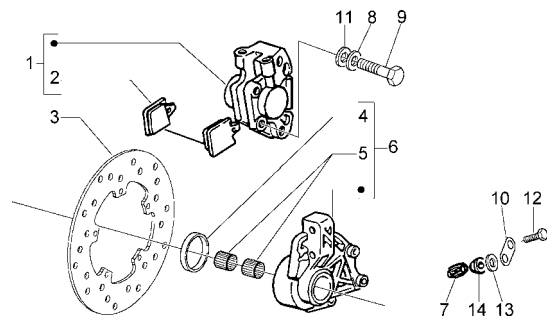

TAV. 31

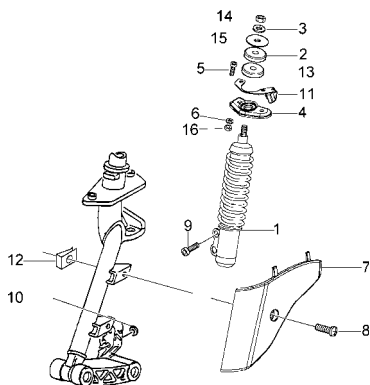

TAV. 32

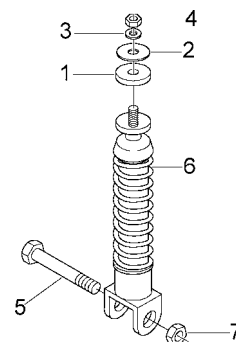



**INDICE DELLE TAVOLE
INDEX ILLUSTRÉ
TABLE INDEX
TAFEL VERZEICHNIS
INDICE DE LAS TABLAS**

ZAPC 386B..5

TAV. 33

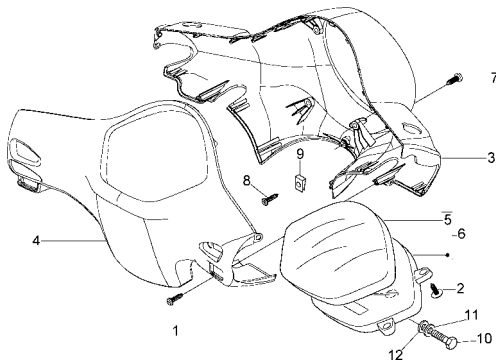

TAV. 34

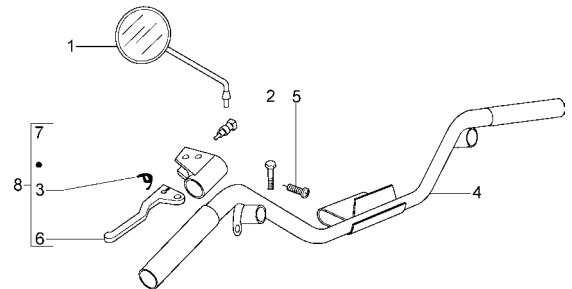

TAV. 35

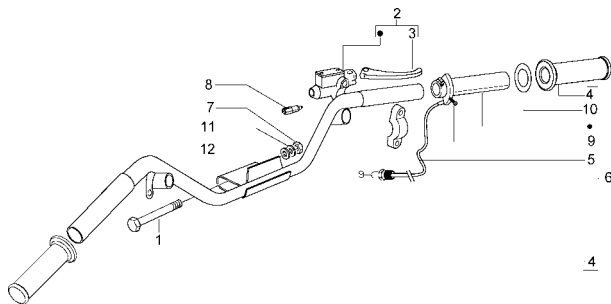

TAV. 36

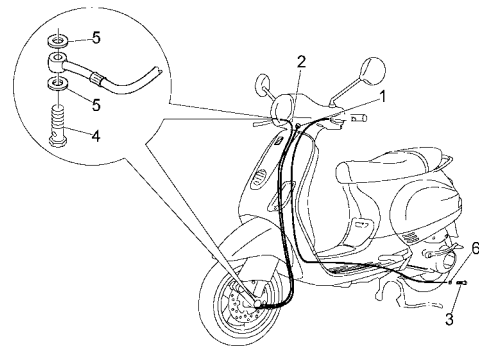

TAV. 37

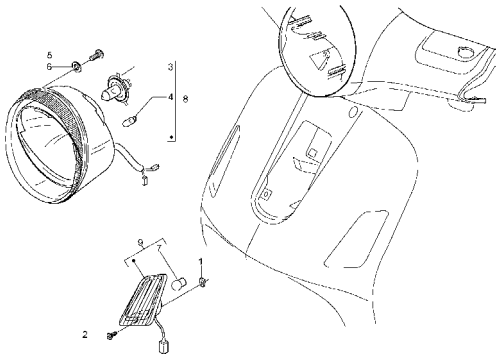

TAV. 38

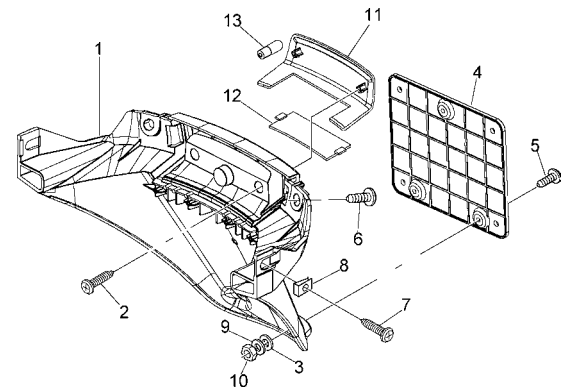

TAV. 39

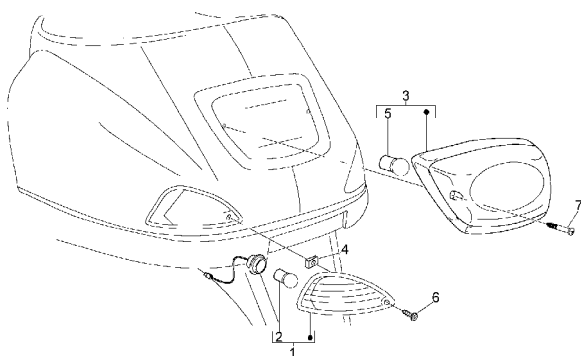

TAV. 40

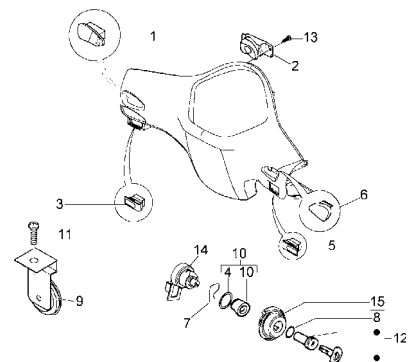



**INDICE DELLE TAVOLE
INDEX ILLUSTRÉ
TABLE INDEX
TAFEL VERZEICHNIS
INDICE DE LAS TABLAS**

ZAPC 386B..5

TAV. 41

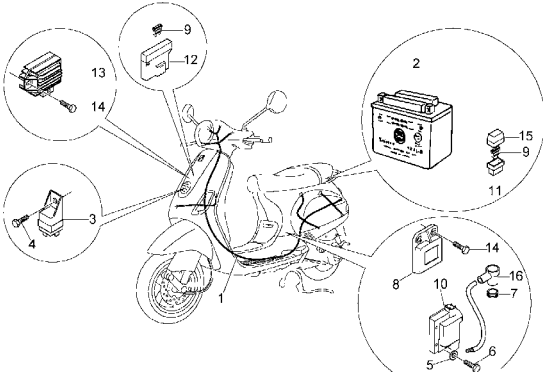

TAV. 42

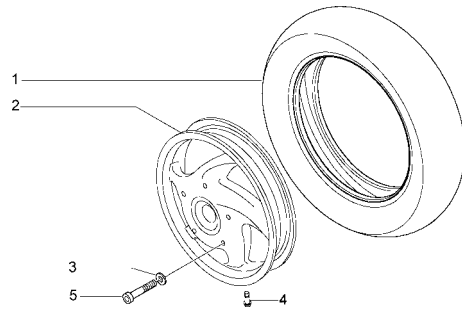

TAV. 43

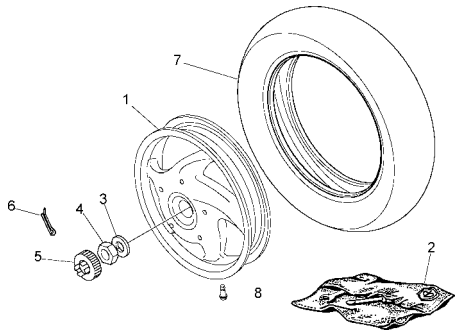

TAV. 44

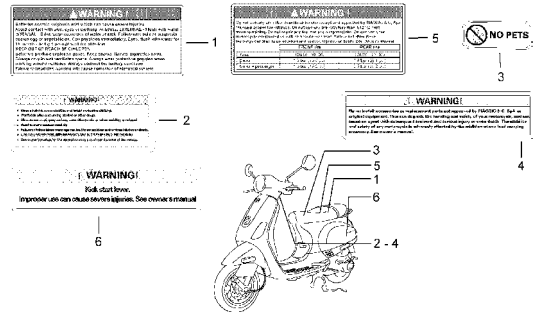

	MOTORE MOTEUR ENGINE MOTOR MOTOR	T. 1
		ZAPC 386B..5

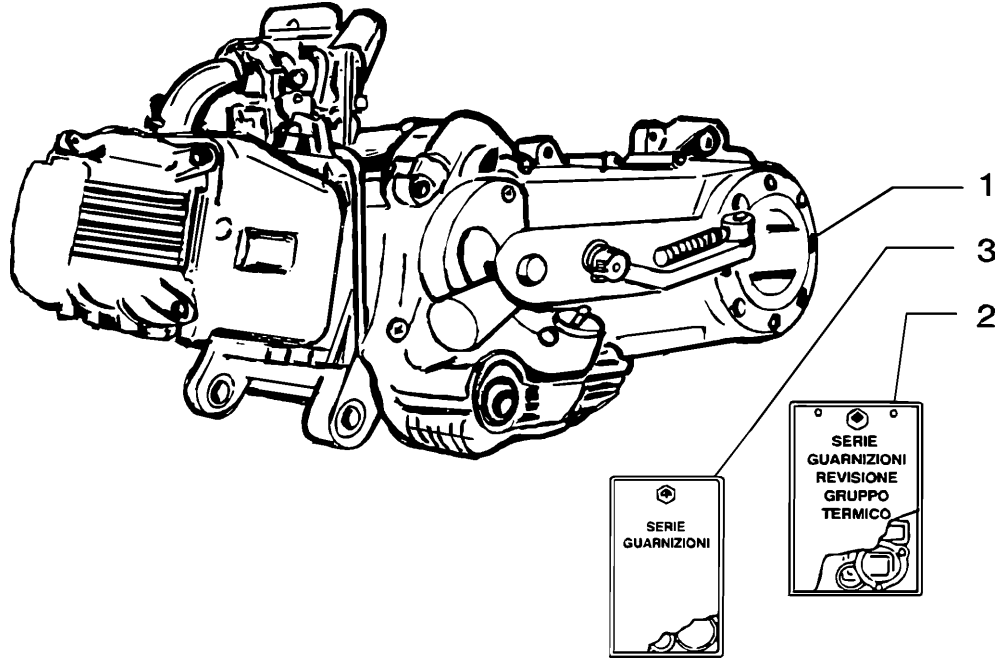

Pos. Pos. Loc. Pos. Pos.	Numero Número Number Nummer Número	Q.tà Q.té Q.ty M.ge Cant.	Nota Note Nota Anm. Nota	Denominazione	Désignation	Description	Beschreibung	Descripción
1	8475125	1		Motore	Moteur	Engine	Motor	Motor
2	497036	1		Serie guarniz. gruppo termico	Set join. groupe thermique	Gask. set thermic unit	Dichtungssatz therm. Einheit	Juego de juntas
3	497037	1		Ser. guarn. e paraoli	Jeu bagues d'et.	Oil seal and gask. set	Dicht. und ölschutz	Juego retenes



**CARTER
CARTER
CRANKCASE
KURBELGEHÄUSE
CARTER**

T. 2

ZAPC 386B..5

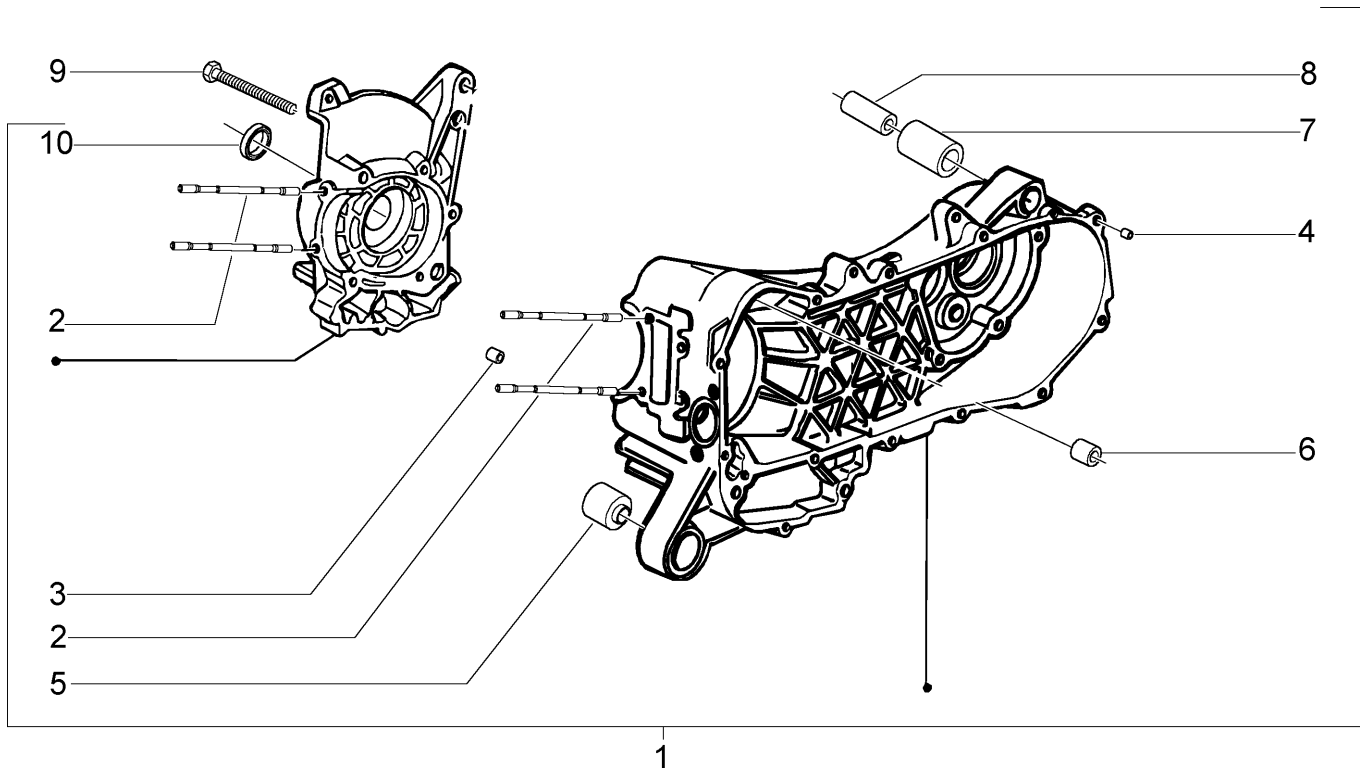

Pos. Pos. Loc. Pos. Pos.	Numero Número Number Nummer Número	Q.tà Q.té Q.ty M.ge Cant.	Nota Note Nota Anm. Nota	Denominazione	Désignation	Description	Beschreibung	Descripción
1	8474875	1		Carter	Carter	Crankcase	Kurbelwellengehäuse	Cárter
2	969012	4		Prigioniero	Goujon	Stud	Stiftschraube	Espárrago
3	239388	2		Spina	Goupille	Pin	Stift	Pasador
4	239388	2		Spina	Goupille	Pin	Stift	Pasador
5	486081	2		Silentbloc	Silentbloc	Sil.block	Puffer	Silent-block
6	431860	1		Bussola	Joint	Bush	Buchse	Buje
7	267823	1		Silentbloc	Silentbloc	Sil.block	Puffer	Silent-block
8	266625	1		Distanziale	Entretoise	Spacer	Distanzstück	Distanciador
9	478895	10		Vite	Vis	Screw	Schraube	Tornillo
10	969028	1		Anello	Circlips	Ring	Ring	Anillo



**ALBERO MOTORE
VILEBREQUIN
CRANKSHAFT
KURBELWELLE
CIGÜENAL**

T. 3

ZAPC 386B..5

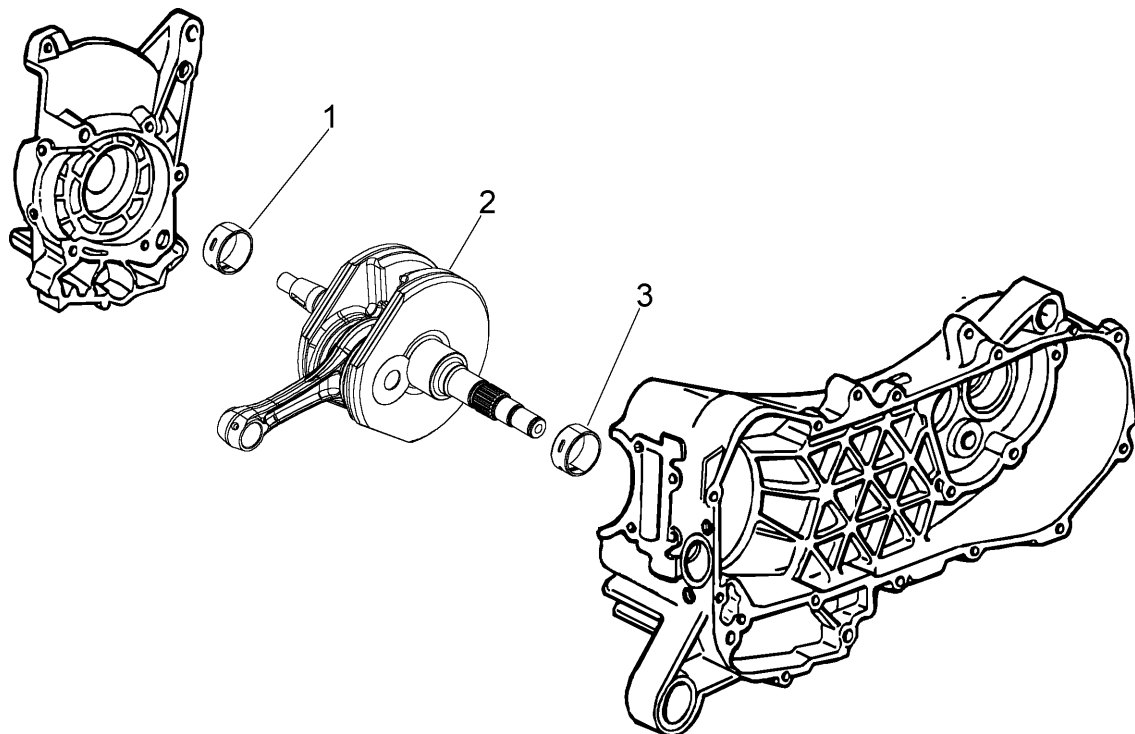

Pos. Pos. Loc. Pos. Pos.	Numero Número Number Nummer Número	Q.tà Q.té Q.ty M.ge Cant.	Nota Note Nota Anm. Nota	Denominazione	Désignation	Description	Beschreibung	Descripción
1	96925R	1		Cuscinetto	Roulement	Bearing	Lager	Cojinete
2	969428	1		Albero motore	Vilebrequin	Crankshaft	Kurbelwelle	Cigüeñal
3	82671R	1		Cuscinetto	Roulement	Bearing	Lager	Cojinete



GRUPPO CILINDRO - PISTONE - SPINOTTO
ENSEMBLE CYLINDRE-PISTON-AXE DE PISTON
CYLINDER-PISTON-WRIST PIN, ASSY
GRUPPE ZYLINDER-KOLBEN-KOLBENBOLZEN
GRUPO CILINDRO-PISTON-EJE DE PISTON

T. 4

ZAPC 386B..5

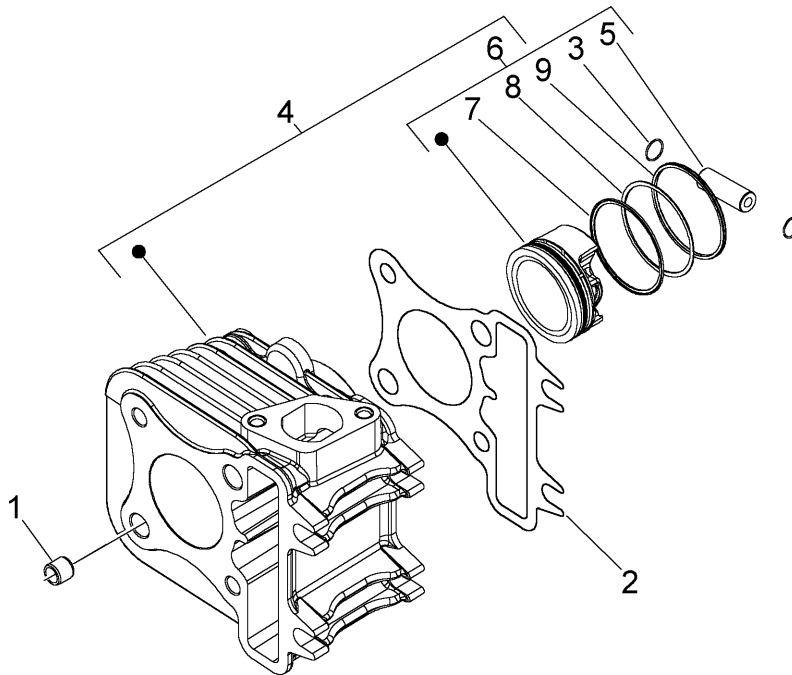

Pos. Pos. Loc. Pos. Pos.	Numero Número Number Nummer Número	Q.tà Q.té Q.ty M.ge Cant.	Nota Note Nota Anm. Nota	Denominazione	Désignation	Description	Beschreibung	Descripción
1	239388	2		Spina	Goupille	Pin	Stift	Pasador
2	969230	1	0,5	Guarnizione	Joint	Packing	Dichtung	Junta
3	969213	2		Anello el.	Circlips	Circlip	Sprengring	Anillo
4	969603	1		Gr.cilindro	Gr.cil.	Cyl.unit	Zylinder	Grupo cilindro
5	969214	1		Spinotto	Axe	Pin	Zapfen	Eje
6	9696045001	1	FC1	Gr.pis.sp.	Ens.pist.	Piston assy	Kolben kpl.	Grupo pistón
6	9696045002	1	FC2	Gr.pis.sp.	Ens.pist.	Piston assy	Kolben kpl.	Grupo pistón
6	9696045003	1	FC3	Gr.pis.sp.	Ens.pist.	Piston assy	Kolben kpl.	Grupo pistón
6	9696045004	1	FC4	Gr.pis.sp.	Ens.pist.	Piston assy	Kolben kpl.	Grupo pistón
7	969215	1		Anello tenuta	Bague d'étanchéite	Oil seal	Dichtring	Reten de ac.
8	969216	1		Anello tenuta	Bague d'étanchéite	Oil seal	Dichtring	Reten de ac.
9	969217	1		Raschiaolio	Segment racleur d'huile	Scraper Ring	Ölabstreifring	Segmento



GR. TESTA - VALVOLE
ENSEMBLE CULASSE - SOUPAPES
CYLINDER HEAD - VALVES
EINHEIT KOPF - VENTIL
CULATA - VÁLVULAS

T. 5

ZAPC 386B..5

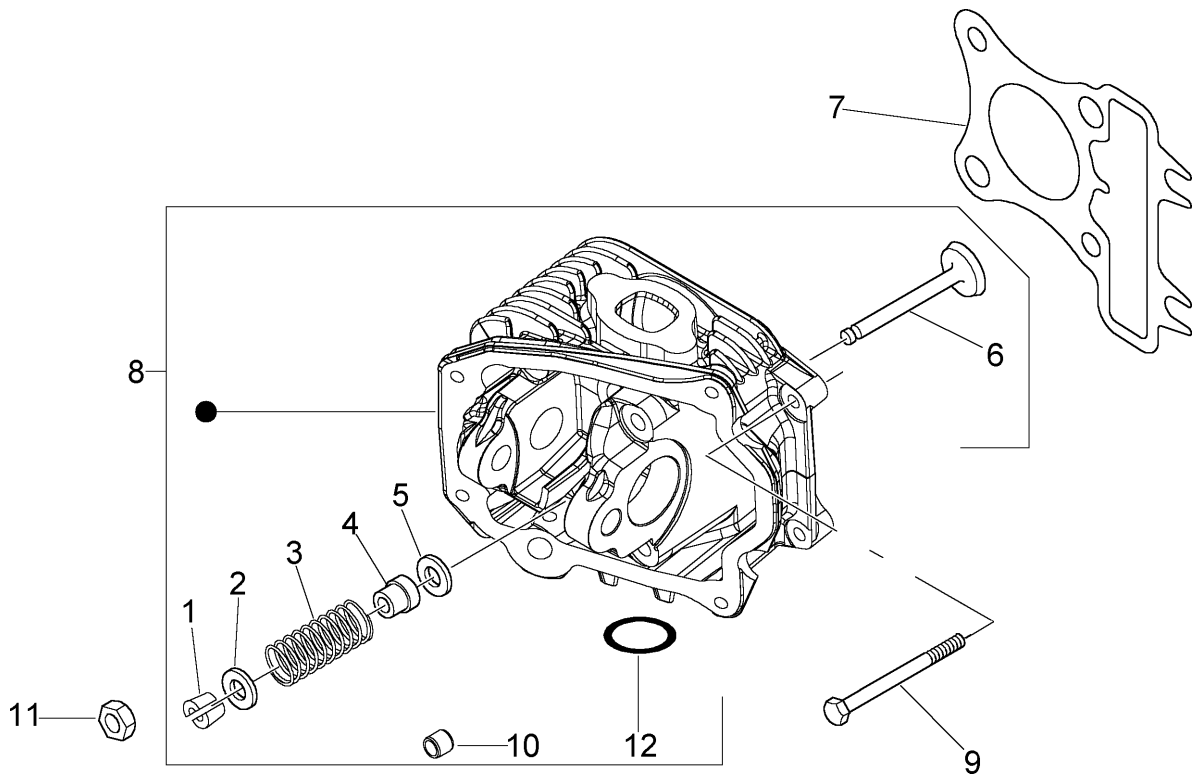

Pos. Pos. Loc. Pos. Pos.	Numero Número	Q.tà Q.té Q.ty M.ge Cant.	Nota Note Nota Anm. Nota	Denominazione	Désignation	Description	Beschreibung	Descrición
1	285846	4		Semicono	Demi bague	Cone, half	Buchse halb	Semicasquillo
2	969267	2		Scodellino	Rondelle d'ar	Stop washer	Federaufnahme	Platillo
3	845782	2		Molla	Ressort	Spring	Feder	Muelle
4	436438	2		Anello di tenuta	Joint spie	Oil seal	Dichtring	Retén de aceite
5	289420	2		Scodellino	Rondelle d'ar	Stop washer	Federaufnahme	Platillo
6	969238	1	ASP	Valvola aspirazione	Soupape aspir.	Suction valve	Einlassventil	Válvula aspiración
6	969239	1	SCA	Valvola di scarico	Soupape d'échapp.	Exhaust valve	Auslassventil	Válvula de descarga
7	832613	1	0,25	Guarnizione	Joint	Packing	Dichtung	Junta
7	832614	1	0,35	Guarnizione	Joint	Packing	Dichtung	Junta
8	845765	1		Testa	Culasse	Cylinder head	Kopf	Culata
9	319242	2		Vite	Vis	Screw	Schraube	Tornillo
10	239388	2		Spina	Goupille	Pin	Stift	Pasador
11	969224	4		Dado	Ecrou	Nut	Mutter	Tuerca
12	969236	1		Guarnizione	Joint	Packing	Dichtung	Junta



GRUPPO SUPPORTO BILANCIERI
ENSEMBLE SUPPORT BILANCIERS
ROCKER LEVERS SUPPORT
EINHEIT KIPPBEHÄLTER
SOPORTE BRAZO OSCILANTE

T. 6

ZAPC 386B..5

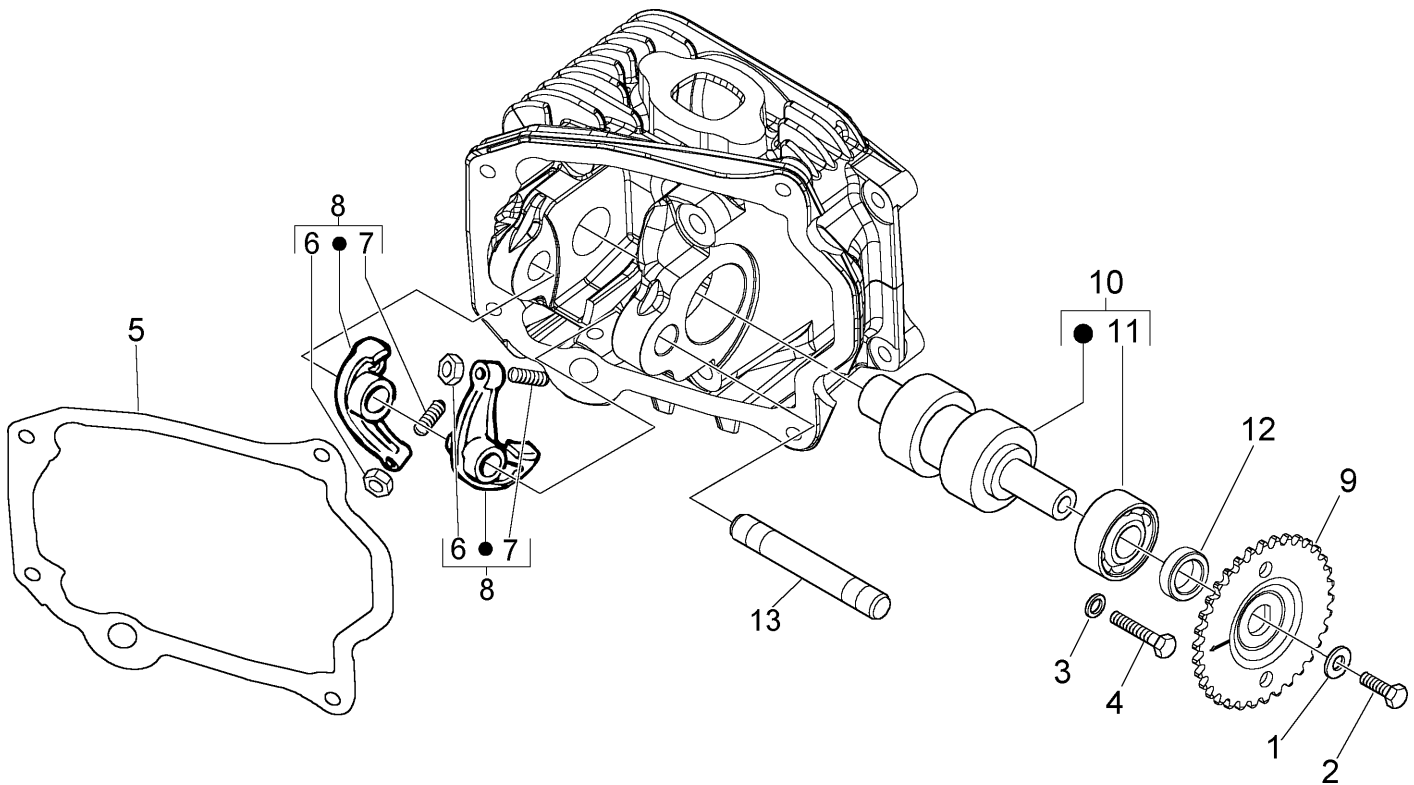

Pos. Pos. Loc. Pos. Pos.	Numero Número Number Nummer Número	Q.tà Q.té Q.ty M.ge Cant.	Nota Note Nota Anm. Nota	Denominazione	Désignation	Description	Beschreibung	Descripción
1	969315	1		Molla a tazza	Ressort á diaphragme	Cup spring	Tassenfeder	Muelle
2	833722	1		Vite fiss.	Vis fix.	Sec. screw	Schraube	Tornillo
3	969315	1		Rondella	Rondelle	Washer	U.Scheibe	Arandela
4	484123	1		Vite	Vis	Screw	Schraube	Tornillo
5	843684	1		Guarnizione	Joint	Packing	Dichtung	Junta
6	484819	2		Dado	Ecrou	Nut	Mutter	Tuerca
7	82817R	2		Vite	Vis	Screw	Schraube	Tornillo
8	9692695	2		Bilanciere	Balancier	Lever	Kipphebel	Balancin
9	434943	1		Corona	Couronne	Ring gear	Zahnkranz	Corona
10	9692475	1		Albero a camme	Arbre á Cames	Camshaft	Nockenwelle	Eje de excéntricas
11	96926R	1		Cuscinetto	Roulement	Bearing	Lager	Cojinete
12	969265	1		Distanziale	Entretoise	Spacer	Distanzstück	Distanciador
13	969268	1		Asse bilancieri	Axe du culbuteurs	Rocker arm shaft	Spindel	Eje brazos oscilantes



**COPERCHIO TESTA
COUVERCLE CULASSE
CILINDER HEAD COVER
ZYLINDERKOPFABDECKUNG
TAPA CULATA**

T. 7

ZAPC 386B..5

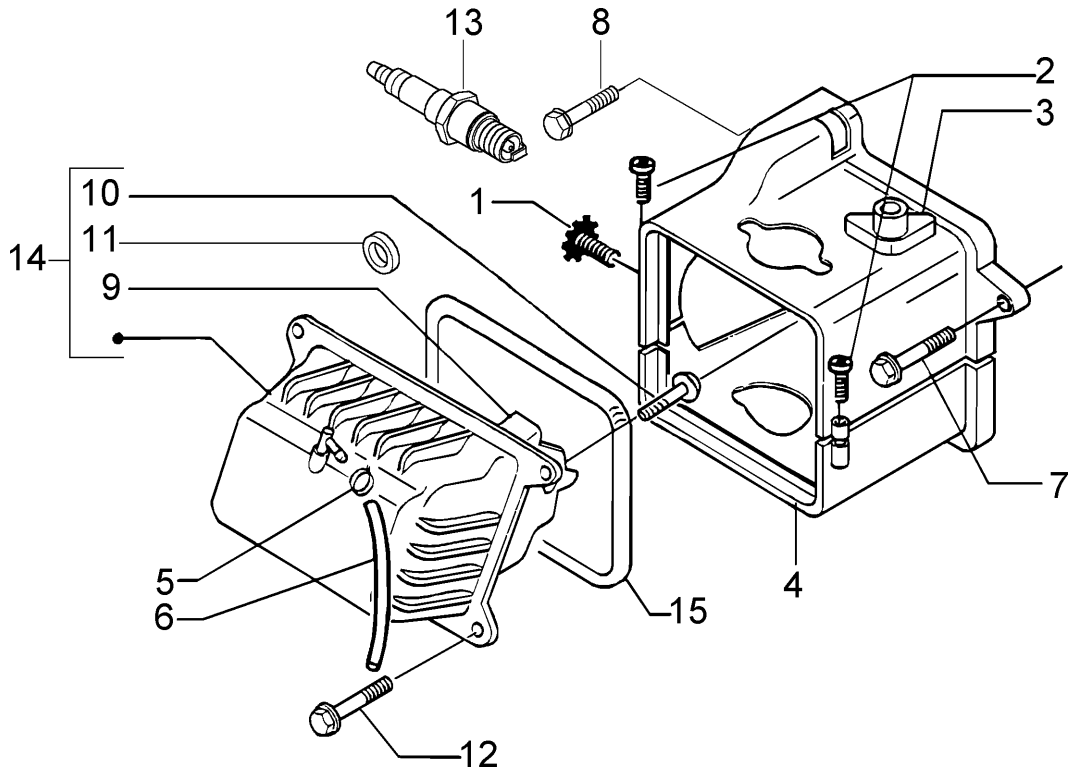

Pos. Pos. Loc. Pos. Pos.	Numero Número Number Number Número	Q.tà Q.té Q.ty M.ge Cant.	Nota Note Nota Anm. Nota	Denominazione	Désignation	Description	Beschreibung	Descripción
1	969339	1		Vite	Vis	Screw	Schraube	Tornillo
2	259577	2		Vite	Vis	Screw	Schraube	Tornillo
3	833471	1		Cuffia	Coiffe	Cooling hood	Haube	Deflector
4	969918	1		Cuffia	Coiffe	Cooling hood	Haube	Deflector
5	CM002908	1		Fascetta	Collier	Clamp	Schelle	Abrazadera
6	969415	1		Tubo sfiato	Tuyau réinflard	Breather tube	Entlüftungsleitung	Tubo respiradero
7	270793	1		Vite	Vis	Screw	Schraube	Tornillo
8	828662	1		Vite	Vis	Screw	Schraube	Tornillo
9	969286	1		Piastra	Plaque	Plate	Platte	Chapa
10	430264	4		Vite	Vis	Screw	Schraube	Tornillo
11	969894	1		Guarnizione BLOW-BY	Joint BLOW-BY	Packing BLOW-BY	Dichtung BLOW-BY	Junta BLOW-BY
12	031091	4		Vite	Vis	Screw	Schraube	Tornillo
13	638853	1		Candela	Bougie	Spark plug	Zündkerze	Bujía
14	832964	1		Coperchio testa	Couvercle culasse	Cylinder head cover	Zylinderkopf- abdeckung	Tapa culata
15	969334	1		Guarnizione	Joint	Packing	Dichtung	Junta



**PULEGGIA CONDOTTA
POULIE ENTRAINEE
DRIVEN PULLEY
GETRIEBENE RIEMENSCHLEIBEN
POLEA CONDUCTIDA**

T. 8

ZAPC 386B..5

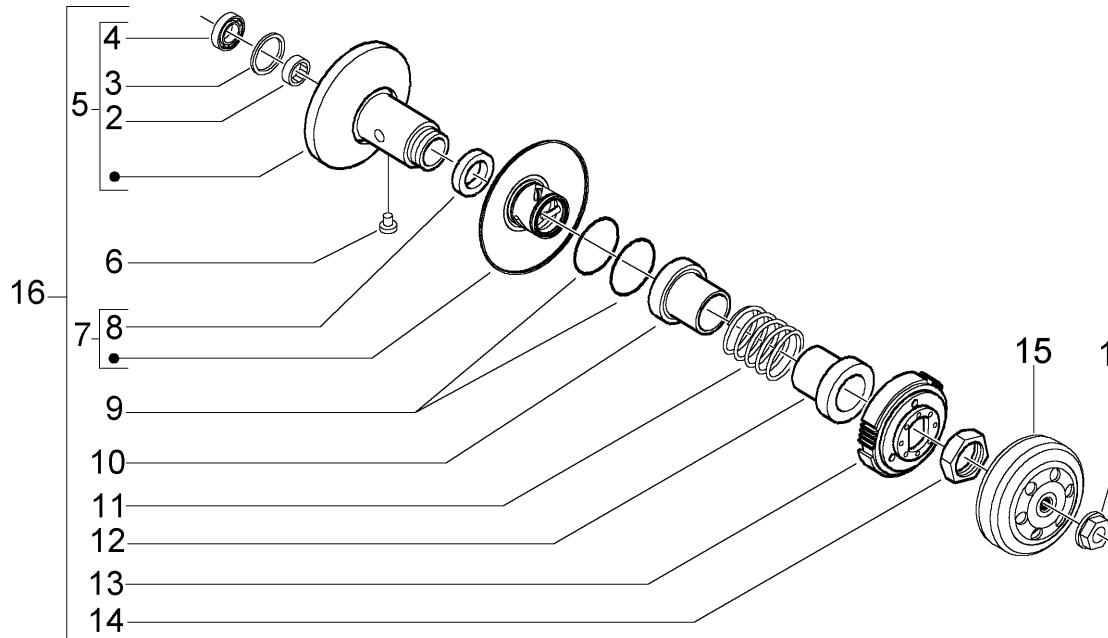

Pos. Pos. Loc. Pos. Pos.	Numero Número Number Nummer Número	Q.tà Q.té Q.ty M.ge Cant.	Nota Note Nota Anm. Nota	Denominazione	Désignation	Description	Beschreibung	Descripción
1	289519	1		Dado	Ecrou	Nut	Mutter	Tuerca
2	82655R	1		Cuscinetto	Roulement	Bearing	Lager	Cojinete
3	006624	1		Anello	Circlips	Ring	Ring	Anillo
4	289952	1		Astuccio a rulli	Cage à roul.	Roller cage	Rollenlagerkafig	Jaula rodillos
5	4795526	1		Semipuleggia	Demi poulie	Pulley, half	Riemenscheibenhälfte	Semipolea
6	482766	3		Perno	Pivot	Pin	Zapfen	Perno
7	827893	1		Semipuleggia	Demi poulie	Pulley, half	Riemenscheibenhälfte	Semipolea
8	289950	2		Anello	Circlips	Ring	Ring	Anillo
9	289840	2		Guarnizione	Joint	Packing	Dichtung	Junta
10	483443	1		Scodellino	Rondelle d'ar	Stop washer	Federaufnahme	Platillo
11	478028	1		Molla	Ressort	Spring	Feder	Muelle
12	487935	1		Scodellino	Rondelle d'ar =	Stop washer	Federaufnahme	Platillo
13	CM1002025	1		Gr.frizione	Gr.embrayage	Clutch assy	Kupplungbacken	Gr.embrague
14	289955	1		Ghiera	Douille	Ring nut	Gewinding	Casquillo
15	289933	1		Tamburo frizione	Tambour d'embr.	Clutch drum	Kupplungstrommel	Tambor de embr.
16	CM100107	1		Puleggia	Poulie	Pulley	Riemenscheibe	Polea



**PULEGGIA MOTRICE
POULIE MOTRICE
DRIVING PULLEY
TREIBENDE RIEMENSCHLEIBEN
POLEA MOTRIZ**

T. 9

ZAPC 386B..5

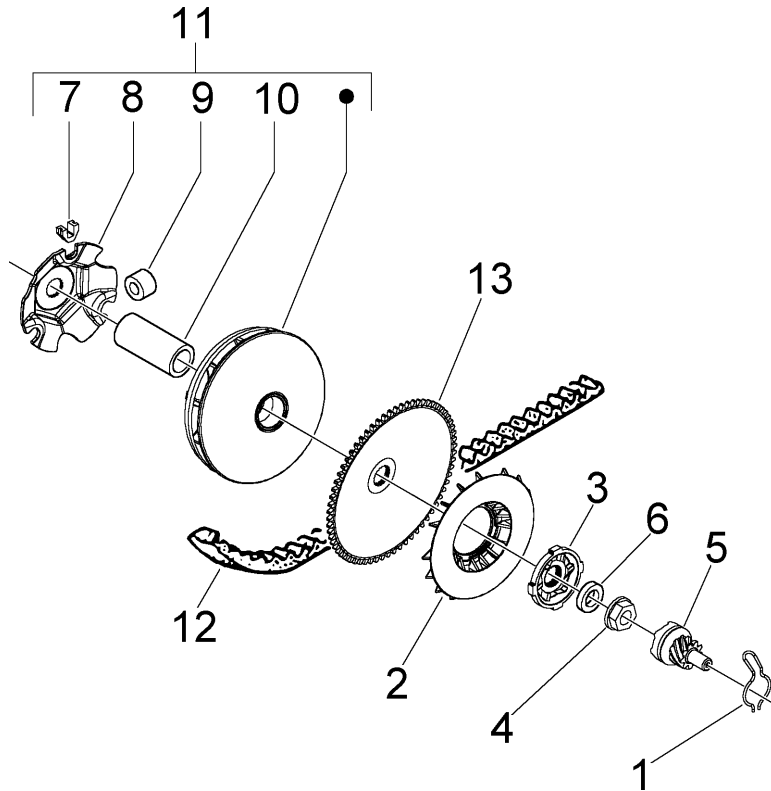

Pos. Pos. Loc. Pos. Pos.	Numero Número Number Number Número	Q.tà Q.té Q.ty M.ge Cant.	Nota Note Nota Anm. Nota	Denominazione	Désignation	Description	Beschreibung	Descripción
1	830212	1		Molletta	Ressort	Spring	Federklammer	Muelle
2	845611	1		Ventola	Ventilateur	Fan	Lüfterrad	Ventilador
3	479866	1		Boccolo	Joint	Bush	Buchse	Casquillo
4	289519	1		Dado	Ecrou	Nut	Mutter	Tuerca
5	483537	1		Pignone	Pignon	Pinion	Ritzel	Piñón
6	265300	1		Rondella	Rondelle	Washer	U.Scheibe	Arandela
7	289931	3		Pattino	Doigt	Shoe	Gleitauflage	Patín
8	480227	1		Contenitore	Logement	Housing	Behälter	Contenedor
9	CM1102025	1		Kit rulli	Kit rouleaux	Rollers kit	Bausatz Rollen	Kit rodillos
10	480230	1		Distanziale	Entretoise	Spacer	Distanzstück	Distanciador
11	CM110301	1		Semipuleggia	Demi poulie	Pulley, half	Riemenscheiben- hälfte	Semipolea
12	82645R	1		Cinghia	Courroie	Belt	Keilriemen	Correa
13	479561	1		Semipuleggia	Demi poulie	Pulley, half	Riemenscheiben- hälfte	Semipolea



MOTORINO AVVIAMENTO - LEVA AVVIAMENTO
DÉMARRÉUR ÉLECTRIQUE - LEVIER DE DEMARRAGE
STARTING MOTOR - STARTER LEVER
ANLASSERMOTOR - KICKSTARTER
MOTOR DE ARRANQUE - PALANCA DE ARRANQUE

T. 10

ZAPC 386B..5

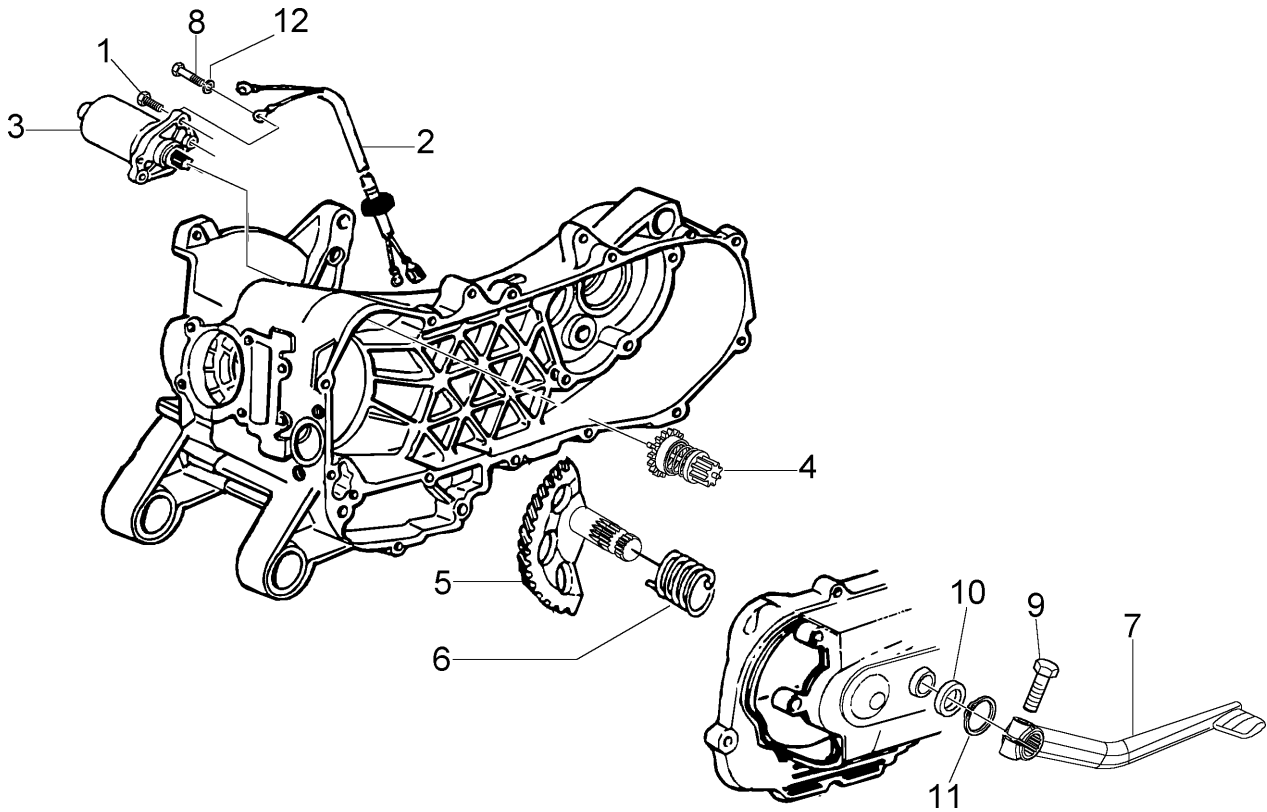

Pos. Pos. Loc. Pos. Pos.	Numero Número Number Nummer Número	Q.tà Q.té Q.ty M.ge Cant.	Nota Note Nota Anm. Nota	Denominazione	Désignation	Description	Beschreibung	Descripción
1	031091	2		Vite	Vis	Screw	Schraube	Tornillo
2	969347	1		Gr.cavetti	Faisceau de câbles	Cable harn.	Kabelbaum	Grupo de cables
3	96921R	1		Motorino avv.	Mot du démar.	Starter motor	Startermotor	Motor de arr.
4	96922R	1		Gruppo rinvio	Ensamble renvoi	Pinion, assy	Ritzel	Grupo reenvío
5	831458	1		Asse m.m.	Arbre démarr.	Start.shaft	Kickersegment	Eje arranque
6	289495	1		Molla	Ressort	Spring	Feder	Muelle
7	969421	1		Leva m.moto	Levier du démarrage	Start. lever	Kickstarterhebel	Palanca de arranque
8	018644	1		Vite	Vis	Screw	Schraube	Tornillo
9	414837	1		Vite fiss.	Vis fix.	Sec. screw	Schraube	Tornillo
10	433987	1		Rosetta	Rondelle	Washer	Federring	Arandela
11	006416	1		Anello el.	Circlips	Circlip	Sprengring	Anillo
12	016404	1		Rondella	Rondelle	Washer	U.Scheibe	Arandela



POMPA OLIO - CARTER OLIO
POMPE D'HUILE - CARTER HUILE
OIL PUMP - OIL PAN
ÖLPUMPE - KURBELGEHÄUSE ÖL
BOMBA DE ACEITE - COLECTOR DE ACEITE

T. 11

ZAPC 386B..5

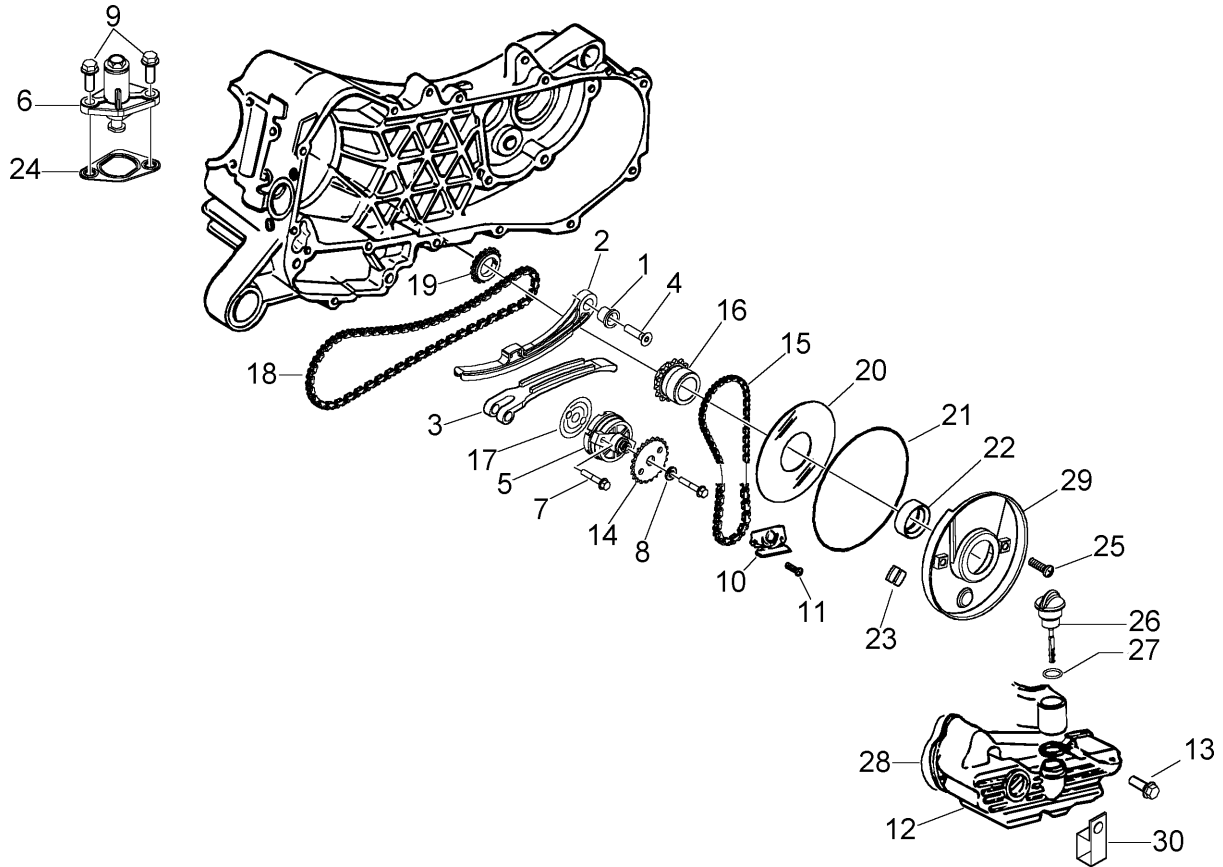

Pos. Pos. Loc. Pos. Pos.	Numero Número Number Nummer Número	Q.tà Q.té Q.ty M.ge Cant.	Nota Note Nota Anm. Nota	Denominazione	Désignation	Description	Beschreibung	Descripción
1	478247	1		Distanziale	Entretoise	Spacer	Distanzstück	Distanciador
2	828561	1		Asta	Tige	Rod	Stange	Varilla
3	969877	1		Pattino	Doigt	Shoe	Gleitauflage	Patín
4	031089	1		Vite	Vis	Screw	Schraube	Tornillo
5	969319	1		Pompa olio	Pompe huile	Oil pump	Ölpumpe	Bomba aceite
6	82650R	1		Supporto tendicatena	Support tendeur de chaîne	Chain tensioner bracket	Halter für Kettenspanner	Soporte tensor de cadena
7	433477	2		Vite	Vis	Screw	Schraube	Tornillo
8	436695	1		Molla a tazza	Ressort à diaphragme	Cup spring	Tassenfeder	Muelle
9	833722	2		Vite fiss.	Vis fix.	Sec. screw	Schraube	Tornillo
10	969625	1		Paratia	Panneau	Panel	Wand	Panel
11	484123	2		Vite	Vis	Screw	Schraube	Tornillo
12	844871	1		Coppa olio	Carter à huile	Pan oil	Ölwanne	Cárter de aceite
13	414837	6		Vite fiss.	Vis fix.	Sec. screw	Schraube	Tornillo
14	287913	1		Corona	Couronne	Ring gear	Zahnkranz	Corona
15	434447	1		Catena	Chaîne	Chain	Kette	Cadena
16	833495	1		Pignone	Pignon	Pinion	Ritzel	Piñón
17	436751	1		Guarnizione	Joint	Packing	Dichtung	Junta
18	96933R	1		Catena	Chaîne	Chain	Kette	Cadena
19	969747	1		Pignone	Pignon	Pinion	Ritzel	Piñón



POMPA OLIO - CARTER OLIO
POMPE D'HUILE - CARTER HUILE
OIL PUMP - OIL PAN
ÖLPUMPE - KURBELGEHÄUSE ÖL
BOMBA DE ACEITE - COLECTOR DE ACEITE

T. 11

ZAPC 386B..5

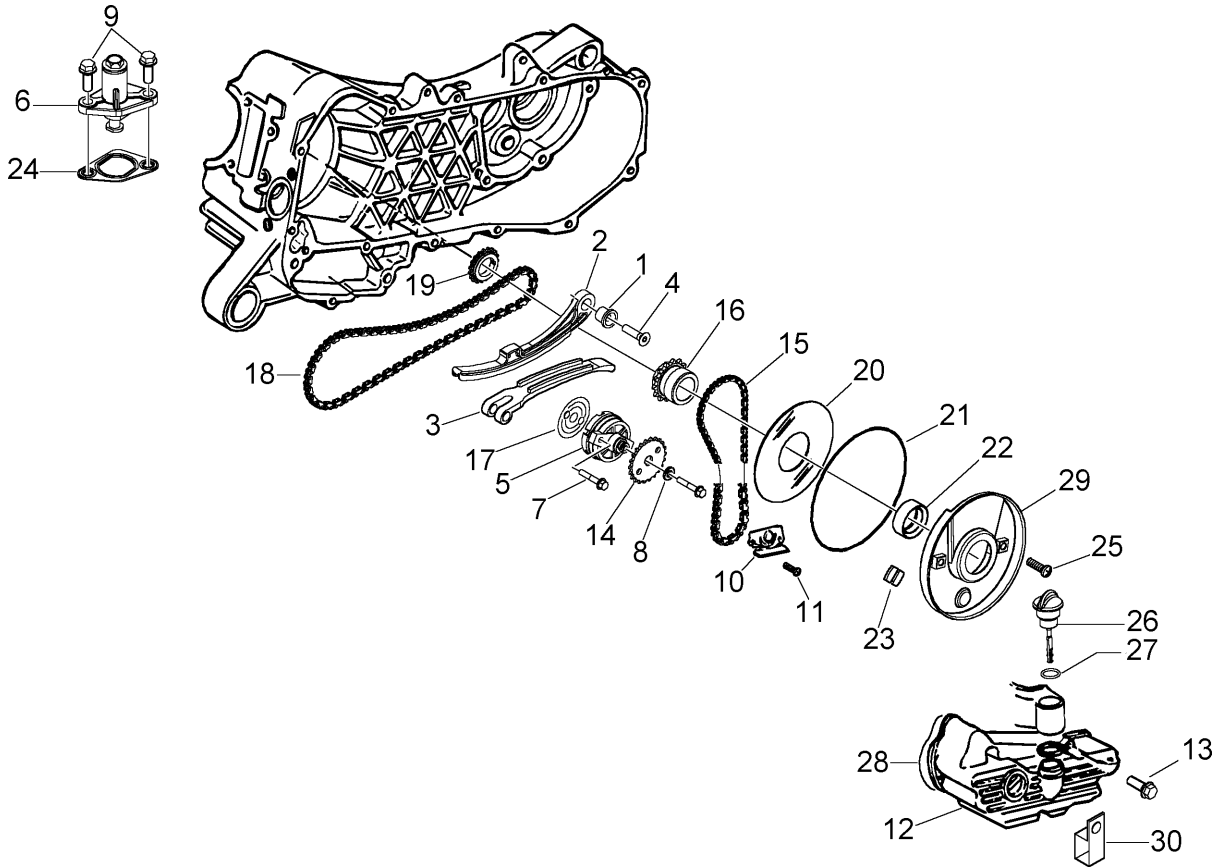

Pos. Pos. Loc. Pos. Pos.	Numero Numéro Number Nummer Número	Q.tà Q.té Q.ty M.ge Cant.	Nota Note Nota Anm. Nota	Denominazione	Désignation	Description	Beschreibung	Descripción
20	430535	1		Rondella	Rondelle	Washer	U.Scheibe	Arandela
21	844888	1		Anello di tenuta	Joint spie	Oil seal	Dichtring	Retén de aceite
22	2879633	1		Anello	Circlips	Ring	Ring	Anillo
23	434345	1		Tampone	Silentbloc	Buffer	Puffer	Silent-block
24	834254	1		Guarnizione	Joint	Packing	Dichtung	Junta
25	484123	3		Vite	Vis	Screw	Schraube	Tornillo
26	844721	1		Asta olio	Jauge niveau d'huile	Oil dipstick	Ölmesstab	Varilla
27	479986	1		Guarnizione	Joint	Packing	Dichtung	Junta
28	969132	1		Guarnizione	Joint	Packing	Dichtung	Junta
29	4783245	1		Coperchio	Couvercle	Cover	Deckel	Tapa
30	487824	1		Fascetta	Collier	Clamp	Schelle	Abrazadera



**COPERCHIO TRASMISSIONE
COUVERCLE TRANSMISSION
TRANSMISSION COVER
ANTRIEBSDECKEL
TAPA DE LA TRANSMISIÓN**

T. 12

ZAPC 386B..5

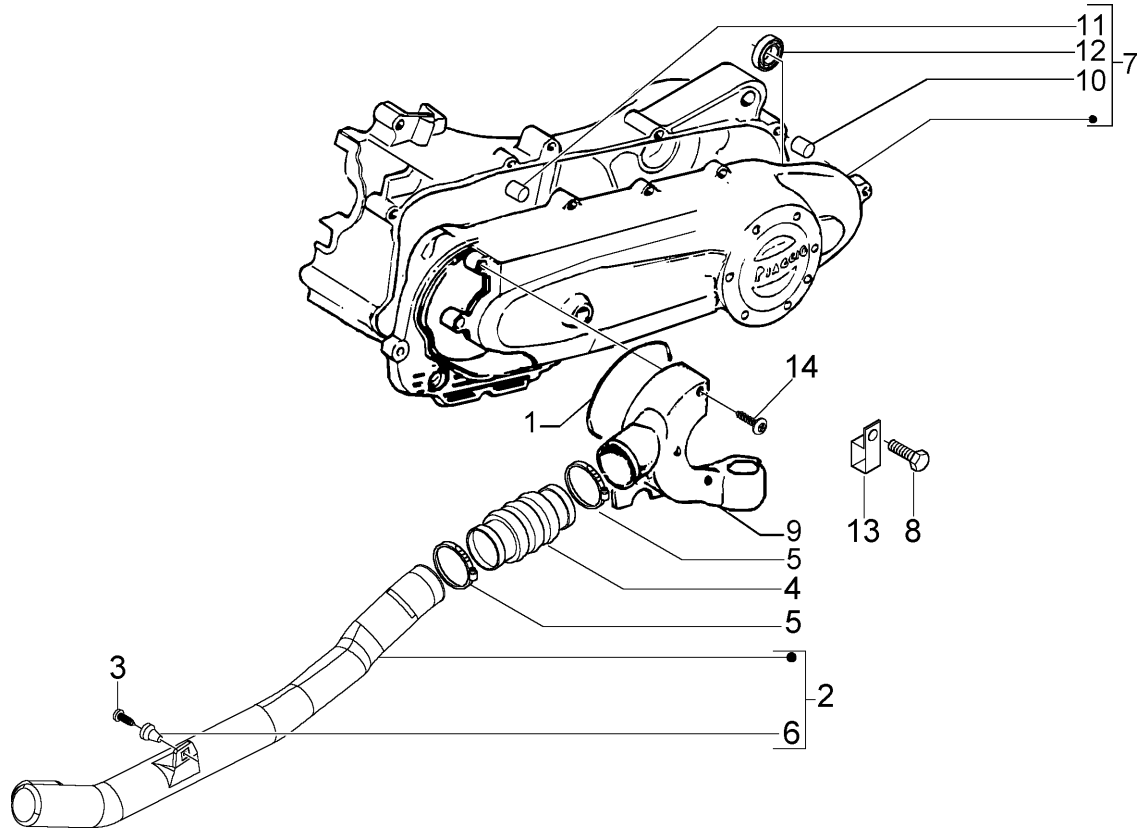

Pos. Pos. Loc. Pos. Pos.	Numero Número	Q.tà Q.té Q.ty M.ge Cant.	Nota Note Nota Anm. Nota	Denominazione	Désignation	Description	Beschreibung	Descripción
1	435251	1		Guarnizione	Joint	Packing	Dichtung	Junta
2	576267	1		Tubo raffreddamento	Tuyau de refroid.	Cooling tube	Kühlleitung	Conducto refriger.
3	267958	1		Vite	Vis	Screw	Schraube	Tornillo
4	298548	1		Soffietto	Manchon	Bellows	Balg	Fuelle
5	145298	2		Fascetta	Collier	Clamp	Schelle	Abrazadera
6	199190	1		Tassello	Taquet	Plate	Pfropfen	Taco
7	9692115	1		Coperchio trasm.	Couvercle transmission	Transmission cover	Getriebeabdeckung	Tapa transmision
8	289731	10		Vite fiss.	Vis fix.	Sec. screw	Schraube	Tornillo
9	969804	1		Coperchio	Couvercle	Cover	Deckel	Tapa
10	239388	2		Spina	Goupille	Pin	Stift	Pasador
11	431860	1		Bussola	Joint	Bush	Buchse	Buje
12	82521R	1		Cuscinetto	Roulement	Bearing	Lager	Cojinete
13	482291	1		Fascetta	Collier	Clamp	Schelle	Abrazadera
14	435295	3		Vite	Vis	Screw	Schraube	Tornillo



**ASSE RUOTA POST.
ARBRE ROUE AR.
REAR WHEEL SHAFT
HINTERRAD ACHSE
EJE RUEDA TRASERA**

T. 13

ZAPC 386B..5

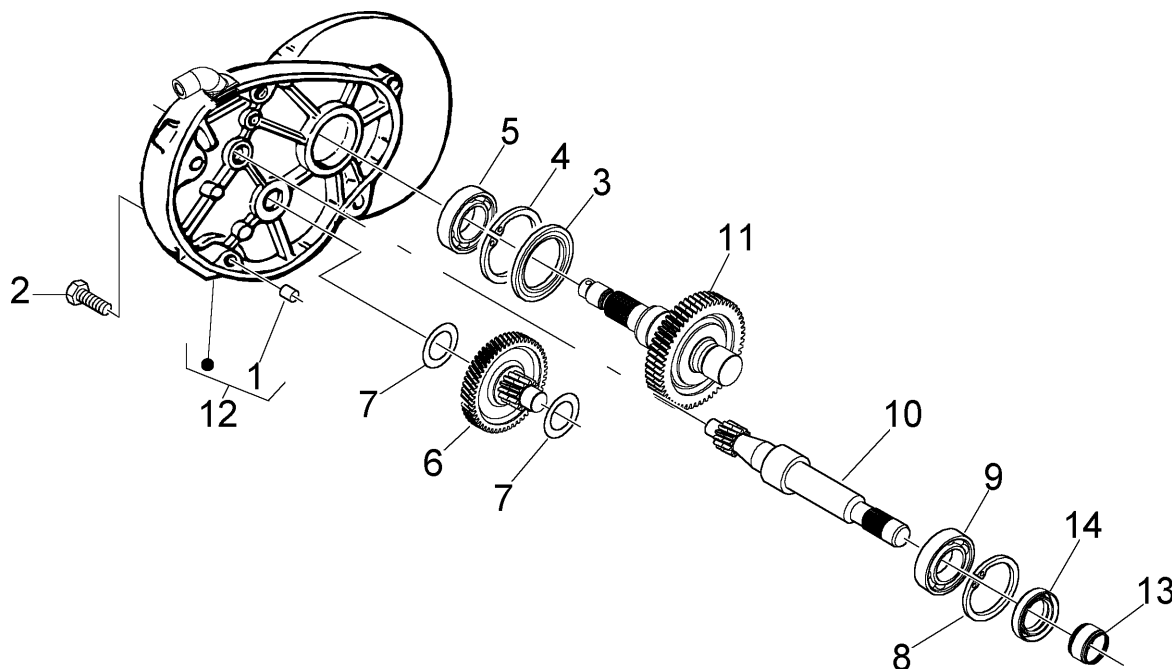

Pos. Pos. Loc. Pos. Pos.	Numero Número Number Nummer Número	Q.tà Q.té Q.ty M.ge Cant.	Nota Note Nota Anm. Nota	Denominazione	Désignation	Description	Beschreibung	Descripción
1	239388	2		Spina	Goupille	Pin	Stift	Pasador
2	414834	5		Vite	Vis	Screw	Schraube	Tornillo
3	478498	1		Anello ten.	Joint spie	Oil seal	Dichtring	Reten de ac.
4	006647	1		Anello	Circlips	Ring	Ring	Anillo
5	434735	1		Cuscinetto	Roulement	Bearing	Lager	Cojinete
6	4802185	1		Albero rinvio	Arbre de renvoi	Countershaft	Vorgelegezahnrad	Eje de reenvio
7	288639	2		Rondella	Rondelle	Washer	U.Scheibe	Arandela
8	480953	1		Anello	Circlips	Ring	Ring	Anillo
9	942135	1		Cuscinetto	Roulement	Bearing	Lager	Cojinete
10	4795935	1		Albero puleggia	Arbre de poulie	Pulley shaft	Scheibenwelle	Eje polea
11	4874855	1		Asse ruota	Axe roue	Wheel axle	Radachse	Eje rueda
12	4874805	1		Coperchio	Couvercle	Cover	Deckel	Tapa
13	478197	1		Anello compensatore	Circlips	Ring	Sprengring	Anillo
14	480066	1		Anello	Circlips	Ring	Ring	Anillo



**VOLANO MAGNETE
VOLANT MAGNETIQUE
FLYWHEEL MAGNETO
LICHTMASCHINE
VOLANTE MAGNETICO**

T. 14

ZAPC 386B..5

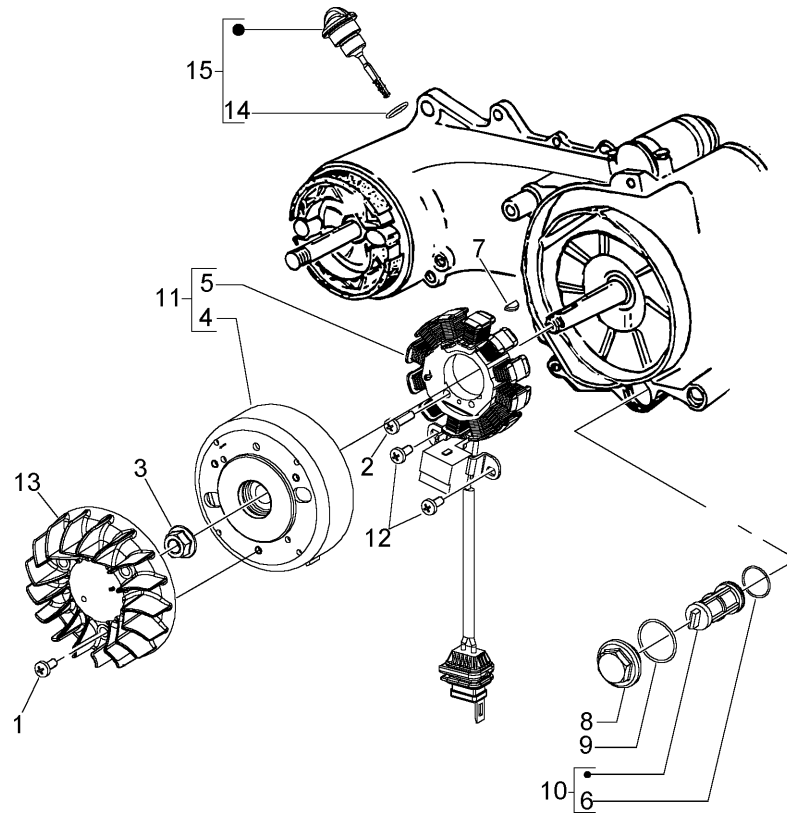

Pos. Pos. Loc. Pos. Pos.	Numero Número Number Number Número	Q.tà Q.té Q.ty M.ge Cant.	Nota Note Nota Anm. Nota	Denominazione	Désignation	Description	Beschreibung	Descripción
1	484123	3		Vite	Vis	Screw	Schraube	Tornillo
2	015856	2		Vite	Vis	Screw	Schraube	Tornillo
3	289005	1		Dado	Ecrou	Nut	Mutter	Tuerca
4	638994	1		Rotore	Rotor	Rotor	Rotor	Rotor
5	638993	1		Statore	Stator	Backplate	Ankerplatte	Estatore
6	288474	1		Guarnizione	Joint	Packing	Dichtung	Junta
7	000267	1		Chiavetta	Clavette	Key	Keil	Chaveta
8	288548	1		Tappo olio	Bouchon huile	Oil plug	Öleinfüllschraube	Tapón aceite
9	285536	1		Anello di tenuta	Joint spie	Oil seal	Dichtring	Retén de aceite
10	431242	1		Filtro	Filtre	Filter	Filter	Filtro
11	82798R	1		Volano magnete	Volant magnetique	Flywh.magn.	Lichtmaschine, kpl.	Volante magn.
12	015585	2		Vite	Vis	Screw	Schraube	Tornillo
13	830286	1		Ventola	Ventilateur	Fan	Lüfterrad	Ventilador
14	827085	1		Guarnizione	Joint	Packing	Dichtung	Junta
15	832130	1		Asta olio	Jauge niveau d'huile	Oil dipstick	Ölmesstab	Varilla



**LEVA FRENO
LEVIER DU FREIN
BRAKE LEVER
BREMSHEBEL
PALANCA FRENO**

T. 15

ZAPC 386B..5

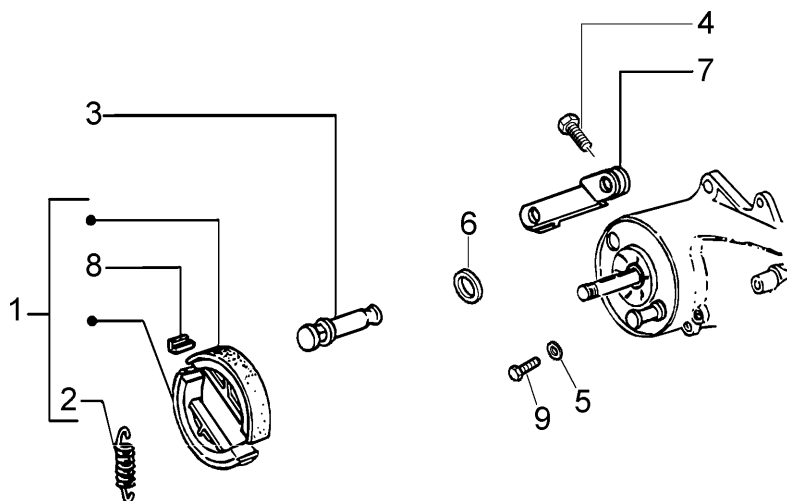

Pos. Pos. Loc. Pos. Pos.	Numero Numéro Number Nummer Número	Q.tà Q.té Q.ty M.ge Cant.	Nota Note Nota Anm. Nota	Denominazione	Désignation	Description	Beschreibung	Descripción
1	2736235	1		Coppia ganasce freno	Couple mâchoires frein	Brake shoes couple	Bremsbackensatz	Juego de zapatas
2	266725	2		Molla	Ressort	Spring	Feder	Muelle
3	274245	1		Asse leva freno	Essieux lever fr.	Brake lever shaft	Bremshebellachse	Eje palanca freno
4	828863	1		Vite fiss.	Vis fix.	Sec. screw	Schraube	Tornillo
5	000397	1		Guarnizione	Joint	Packing	Dichtung	Junta
6	273419	1		Parapolvere	Pare-poussière	Dust cover	Staubdeckel	Guardapolvo
7	833788	1		Leva freno	Levier du frein	Brake lever	Bremshebel	Palanca de freno
8	266724	2		Piastra	Plaque	Plate	Platte	Chapa
9	269755	1		Vite	Vis	Screw	Schraube	Tornillo



**CARBURATORE
CARBURATEUR
CARBURETTOR
VERGASER
CARBURADOR**

T. 16

ZAPC 386B..5

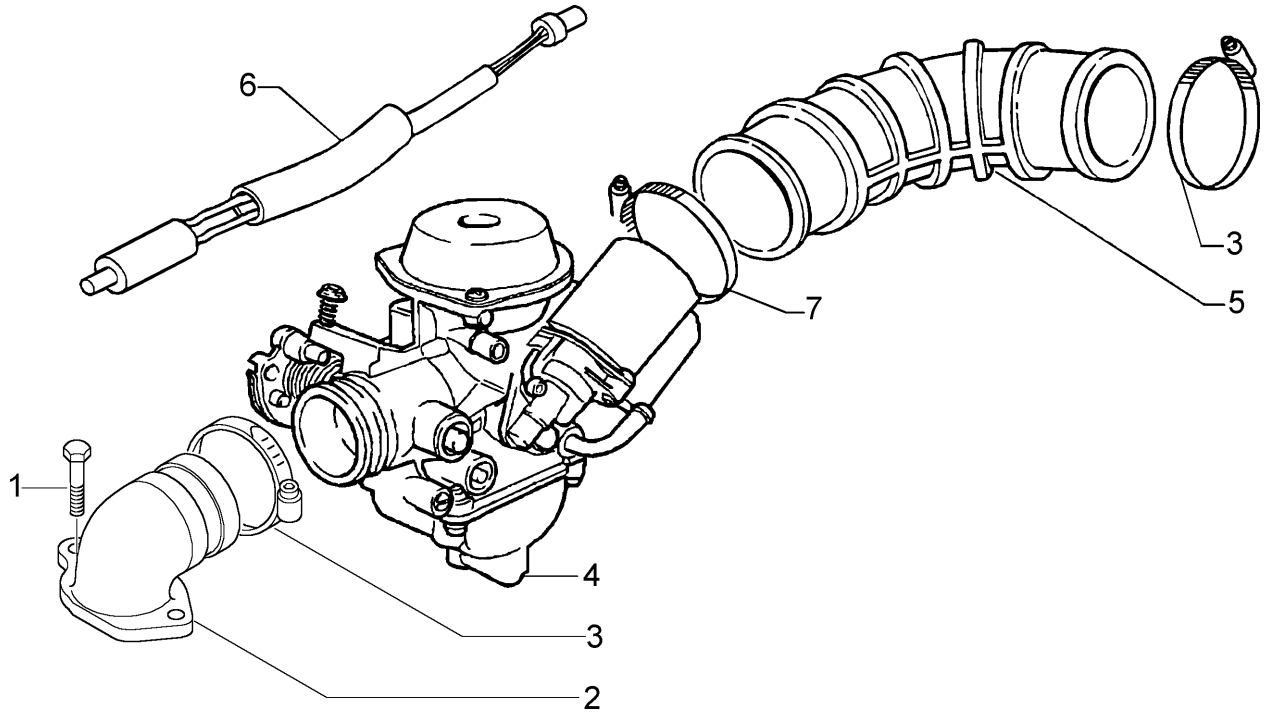

Pos. Pos. Loc. Pos. Pos.	Numero Numéro Number Nummer Número	Q.tà Q.té Q.ty M.ge Cant.	Nota Note Nota Anm. Nota	Denominazione	Désignation	Description	Beschreibung	Descripción
1	031091	2		Vite	Vis	Screw	Schraube	Tornillo
2	845946	1		Raccordo Amm.	Racc. d'admiss.	Union pipe	Ansaugstutzen	Rac. admisión
3	709532	2		Fascetta	Collier	Clamp	Schelle	Abrazadera
4	CM141906	1		Carburatore	Carburateur	Carburettor	Vergaser	Carburador
5	845489	1		Manicotto	Manchon	Sleeve	Muffe	Manguito
6	582619	1		Resistenza	Résistance	Resistance	Widerstand	Resistencia
7	709532	1		Fascetta	Collier	Clamp	Schelle	Abrazadera



**CARBURATORE
CARBURATEUR
CARBURETTOR
VERGASER
CARBURADOR**

T. 17

ZAPC 386B..5

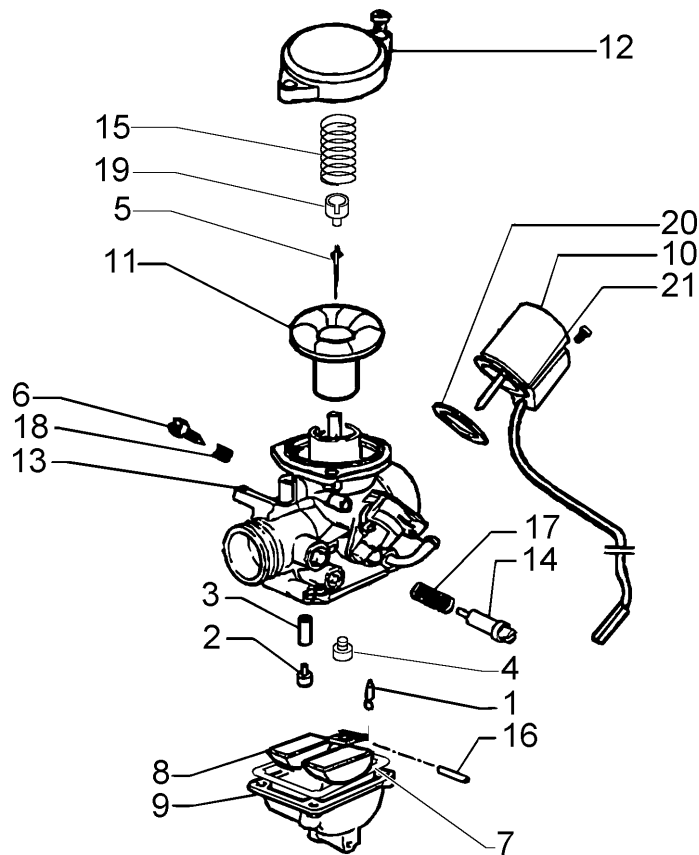

Pos. Pos. Loc. Pos. Pos.	Numero Numéro Number Nummer Número	Q.tà Q.té Q.ty M.ge Cant.	Nota Note Nota Anm. Nota	Denominazione	Désignation	Description	Beschreibung	Descripción
1	CM147101	1		Spillo	Pointeau	Needle	Düsennadel	Aguja
2	CM142102	1	75	Getto max	Gicl.maxi	Main jet	Hauptdüse	Surtidor max
3	828825	1		Emulsionatore	Emulseur	Diffuser	Mischrohr	Emulsor
4	CM142302	1		Getto min.	Gicleur ralenti	Idling jet	Leerlaufdü.	Surtidor ralenti
5	CM142705	1		Spillo conico	Pointeau con.	Conical needle	Nadelventil.	Aguja con.
6	828840	1		Vite reg.	Vis	Screw	Schraube regelung	Tornillo regulación
7	497038	1		Guarnizione	Joint	Packing	Dichtung	Junta
8	828832	1		Galleggiante	Flotteur	Float	Schwimmer	Flotador
9	CM142805	1		Vaschetta	Cuvette	Float ch.	Schwimmergehäuse	Cuba
10	828844	1		Cappuccio	Cache	Cap	Kappe	Capuchón
11	CM146601	1		Membrana	Membrane	Diaphragm	Membrane	Membrana
12	828824	1		Coperchio	Couvercle	Cover	Deckel	Tapa
13	828839	1		Leva	Levier	Lever	Hebel	Palanca
14	CM151704	1		Vite reg.	Vis	Screw	Schraube regelung	Tornillo regulación
15	CM142402	1		Molla	Ressort	Spring	Feder	Muelle
16	828833	1		Perno	Pivot	Pin	Zapfen	Perno
17	828830	1		Molla	Ressort	Spring	Feder	Muelle
18	828841	1		Molla	Ressort	Spring	Feder	Muelle
19	828822	1		Sede spillo	Siège de l'aiguille	Needle seat	Nadelsitz	Asiento del obturador



**CARBURATORE
CARBURATEUR
CARBURETTOR
VERGASER
CARBURADOR**

T. 17

ZAPC 386B..5

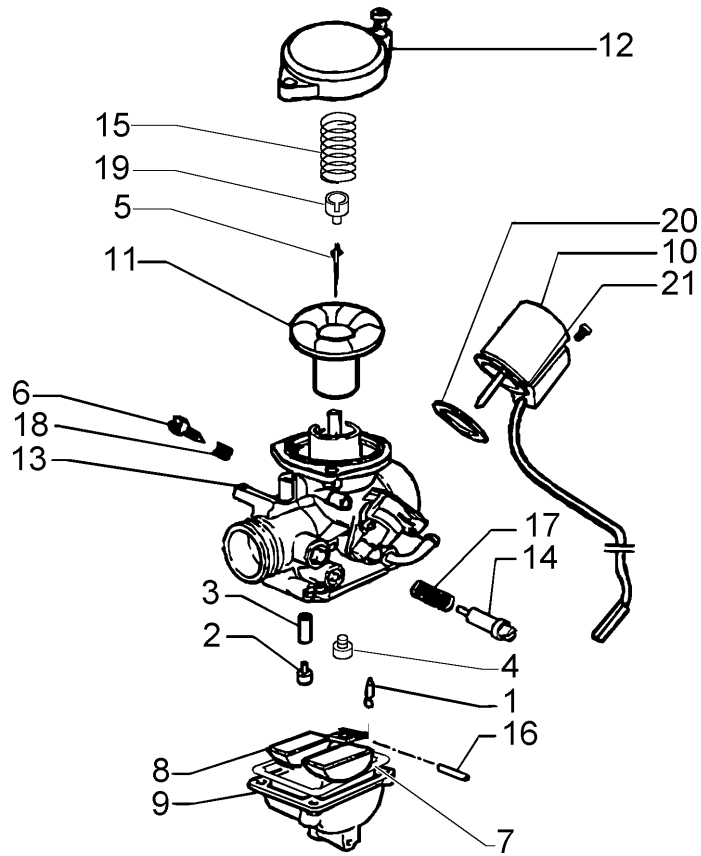

Pos. Pos. Loc. Pos. Pos.	Numero Numéro Number Nummer Número	Q.tà Q.té Q.ty M.ge Cant.	Nota Note Nota Anm. Nota	Denominazione	Désignation	Description	Beschreibung	Descripción
20	828843	1		Piastrina	Plaquette	Plate	Plättchen	Placa
21	CM142910	1		Dispositivo starter	Dispositif starter	Starter unit	Startervorrichtung	Dispositivo estrang. aire



**DEPURATORE
FILTRE A AIR
AIR CLEANER
LUFTFILTER
FILTRO DE AIRE**

T. 18

ZAPC 386B..5

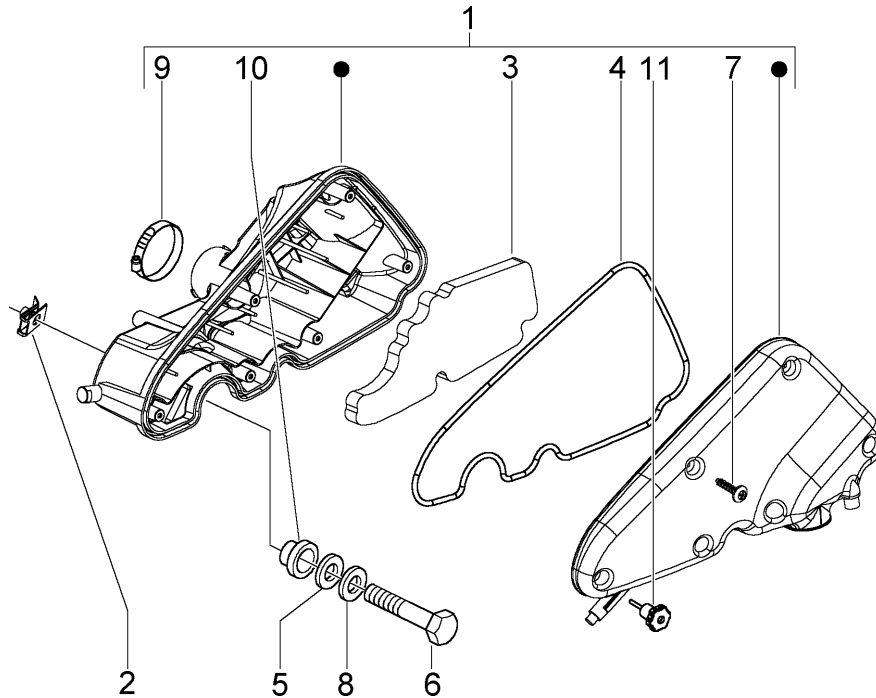

Pos. Pos. Loc. Pos. Pos.	Numero Numéro Number Nummer Número	Q.tà Q.té Q.ty M.ge Cant.	Nota Note Nota Anm. Nota	Denominazione	Désignation	Description	Beschreibung	Descripción
1	847622	1		Scatola dep.	Boîte filtre	Air.cl.case	Luftfiltergehäuse	Caja filtro
2	254485	2		Piastrina	Plaquette	Plate	Plättchen	Placa
3	843194	1		Filtro aria	Filtre á air	Air filter	Luftfilter	Filtro de aire
4	843195	1		Guarnizione	Joint	Packing	Dichtung	Junta
5	012533	1		Rondella	Rondelle	Washer	U.Scheibe	Arandela
6	018640	2		Vite	Vis	Screw	Schraube	Tornillo
7	258146	5		Vite	Vis	Screw	Schraube	Tornillo
8	003056	2		Rondella	Rondelle	Washer	U.Scheibe	Arandela
9	CM002910	2		Fascetta	Collier	Clamp	Schelle	Abrazadera
10	830056	4		Bussola	Joint	Bush	Buchse	Buje
11	479132	1		Pomello	Bouton	Knob	Drehknopf	Pomo



SCATOLA ARIA SECONDARIA
BOITÏ AIR SECONDAIRE
SECONDARY AIR BOX
GEHÄUSE NEBENLUFT
CAJA AIRE SECUNDARIO

T. 19

ZAPC 386B..5

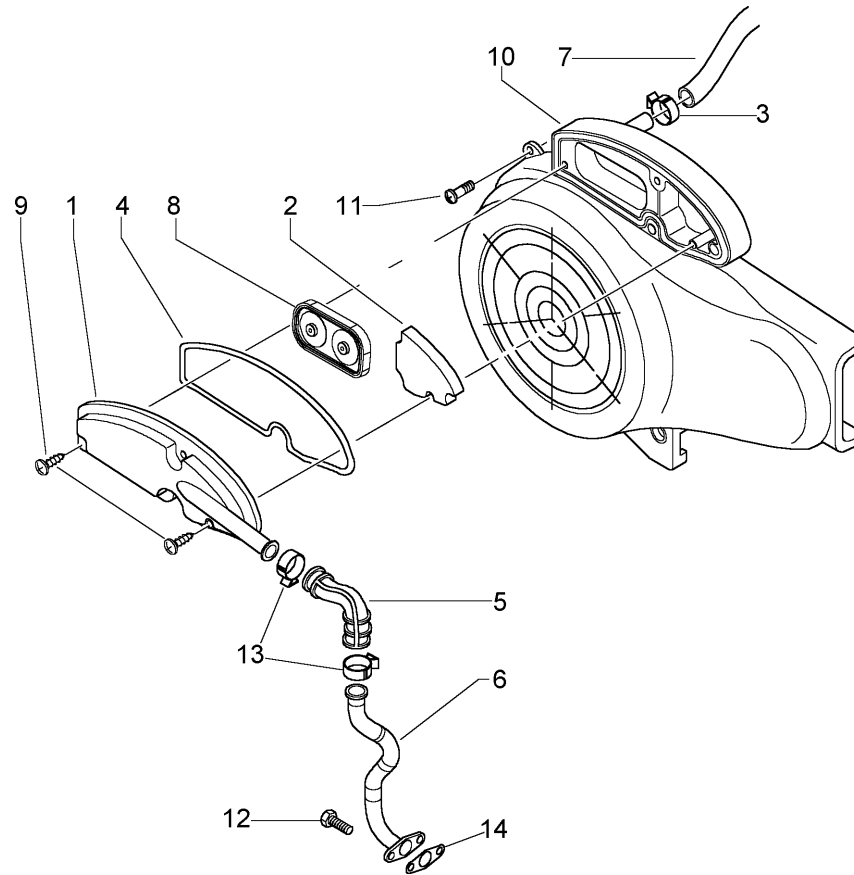

Pos. Pos. Loc. Pos. Pos.	Numero Número Number Nummer Número	Q.tà Q.té Q.ty M.ge Cant.	Nota Note Nota Anm. Nota	Denominazione	Désignation	Description	Beschreibung	Descripción
1	832971	1		Coperchio	Couvercle	Cover	Deckel	Tapa
2	832972	1		Filtro	Filtre	Filter	Filter	Filtro
3	CM001903	1		Fascetta	Collier	Clamp	Schelle	Abrazadera
4	832973	1		Guarnizione	Joint	Packing	Dichtung	Junta
5	833472	1		Manicotto	Manchon	Sleeve	Muffe	Manguito
6	833473	1		Tubo	Tuyau	Tube	Schlauch	Tubo
7	843525	1		Tubo	Tuyau	Tube	Schlauch	Tubo
8	82758R	1		Supporto	Support	Bracket	Halter	Soporte
9	478533	3		Vite	Vis	Screw	Schraube	Tornillo
10	843567	1		Coperchio chiocciola	Couvercle canalisation	Fan cover	Lüftergehäusedeckel	Tapa caracol
11	259151	3		Vite	Vis	Screw	Schraube	Tornillo
12	833722	2		Vite	Vis	Screw	Schraube	Tornillo
13	CM001905	2		Fascetta	Collier	Clamp	Schelle	Abrazadera
14	832059	1		Guarnizione	Joint	Packing	Dichtung	Junta



**MARMITTA
SILENCIEUX
SILENCER
AUSPUFF
SILENCIADOR ESCAPE**

T. 20

ZAPC 386B..5

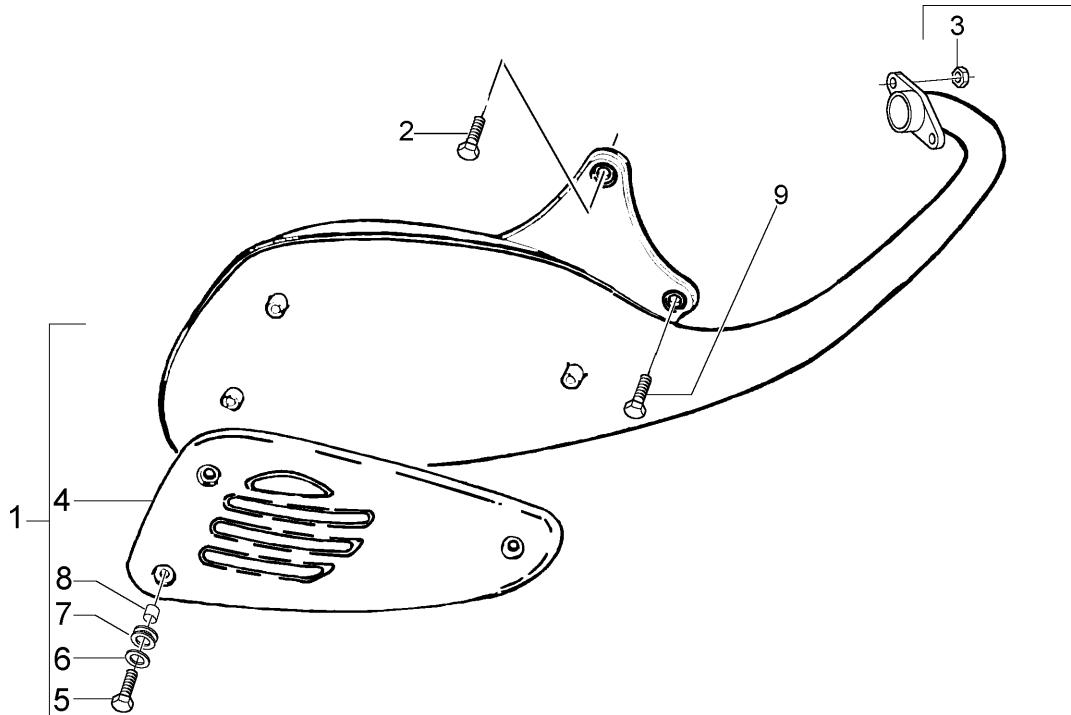

Pos. Pos. Loc. Pos. Pos.	Numero Numéro Number Nummer Número	Q.tà Q.té Q.ty M.ge Cant.	Nota Note Nota Anm. Nota	Denominazione	Désignation	Description	Beschreibung	Descripción
1	8474885	1		Marmitta	Silencieux	Silencer	Auspufftopf	Silenciador
2	297582	1		Vite	Vis	Screw	Schraube	Tornillo
3	833494	2		Dado	Ecrou	Nut	Mutter	Tuerca
4	845465	1		Protezione	Protection	Protection	Schutzstück	Protección
5	433800	3		Vite	Vis	Screw	Schraube	Tornillo
6	828583	3		Rondella	Rondelle	Washer	U.Scheibe	Arandela
7	841782	3		Tampone	Silentbloc	Buffer	Puffer	Silent-block
8	843213	3		Distanziale	Entretoise	Spacer	Distanzstück	Distanciador
9	478761	1		Vite	Vis	Screw	Schraube	Tornillo



CAVALLETTO - BRACCIO OSCILLANTE
BEQUILLE - BRAS OSCILLANT
CENTRAL STAND - SWINGING ARM
KIPPSTÄNDER - SCHWINGARM
CABALLETE - BRAZO OSCILANTE

T. 21

ZAPC 386B..5

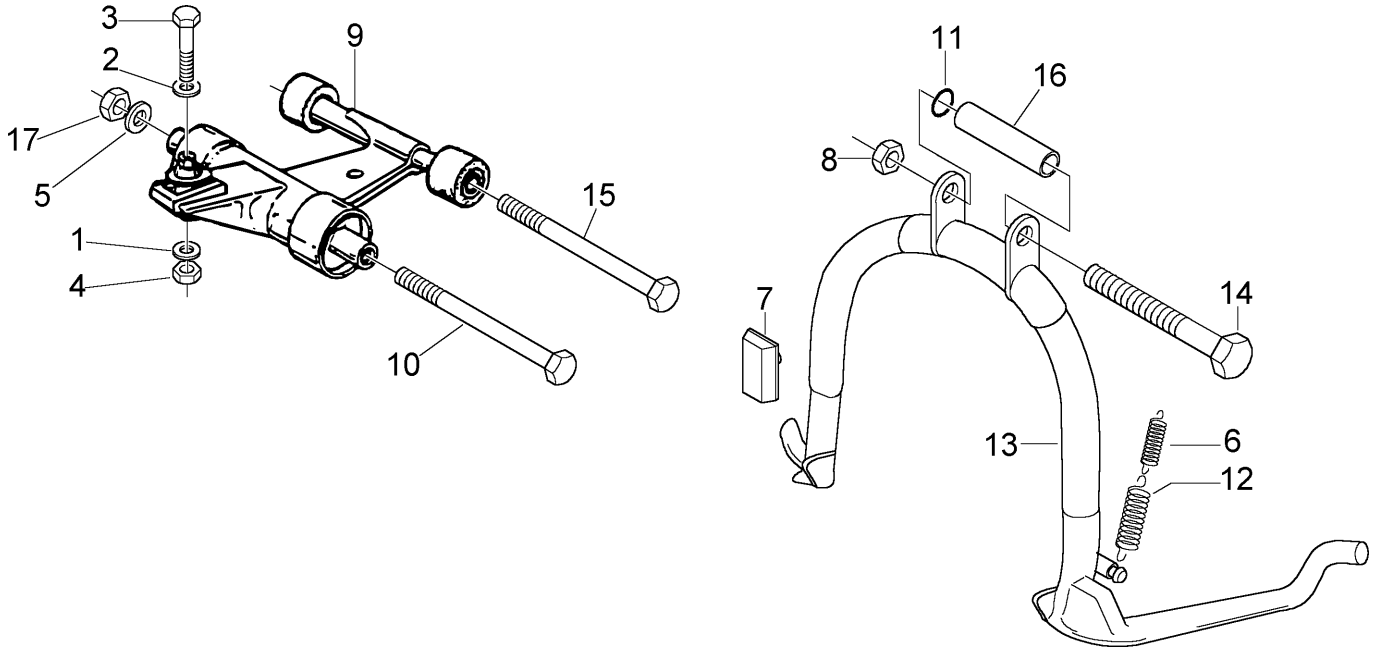

Pos. Pos. Loc. Pos. Pos.	Numero Número	Q.tà Q.té Q.ty M.ge Cant.	Nota Note Nota Anm. Nota	Denominazione	Désignation	Description	Beschreibung	Descripción
1	122781	1		Rondella	Rondelle	Washer	U.Scheibe	Arandela
2	178790	1		Rondella	Rondelle	Washer	U.Scheibe	Arandela
3	560045	1		Vite	Vis	Screw	Schraube	Tornillo
4	232108	2		Dado	Ecrou	Nut	Mutter	Tuerca
5	709037	1		Rondella	Rondelle	Washer	U.Scheibe	Arandela
6	582504	1		Molla	Ressort	Spring	Feder	Muelle
7	563984	1		Tampone	Silentbloc	Buffer	Puffer	Silent-block
8	232108	1		Dado	Ecrou	Nut	Mutter	Tuerca
9	56204R	1		Braccio oscillante	Bras oscillant	Swinging arm	Schwingarm	Brazo oscilante
10	560565	1		Bullone	Boulon	Bolt	Bolzen	Tornillo
11	273754	2		Anello ten.	Joint spie	Oil seal	Dichtring	Reten de ac.
12	582505	1		Molla	Ressort	Spring	Feder	Muelle
13	582060	1		Cavalletto	Béquille	Central stand	Kippständer	Caballete
14	030115	1		Vite	Vis	Screw	Schraube	Tornillo
15	271779	1		Vite	Vis	Screw	Schraube	Tornillo
16	582298	1		Distanziale	Entretoise	Spacer	Distanzstück	Distanciador
17	261319	1		Dado	Ecrou	Nut	Mutter	Tuerca



**SCocca
COQUE
BODYWORK
KAROSSERIE
CARROCIERÍA**

T. 22

ZAPC 386B..5

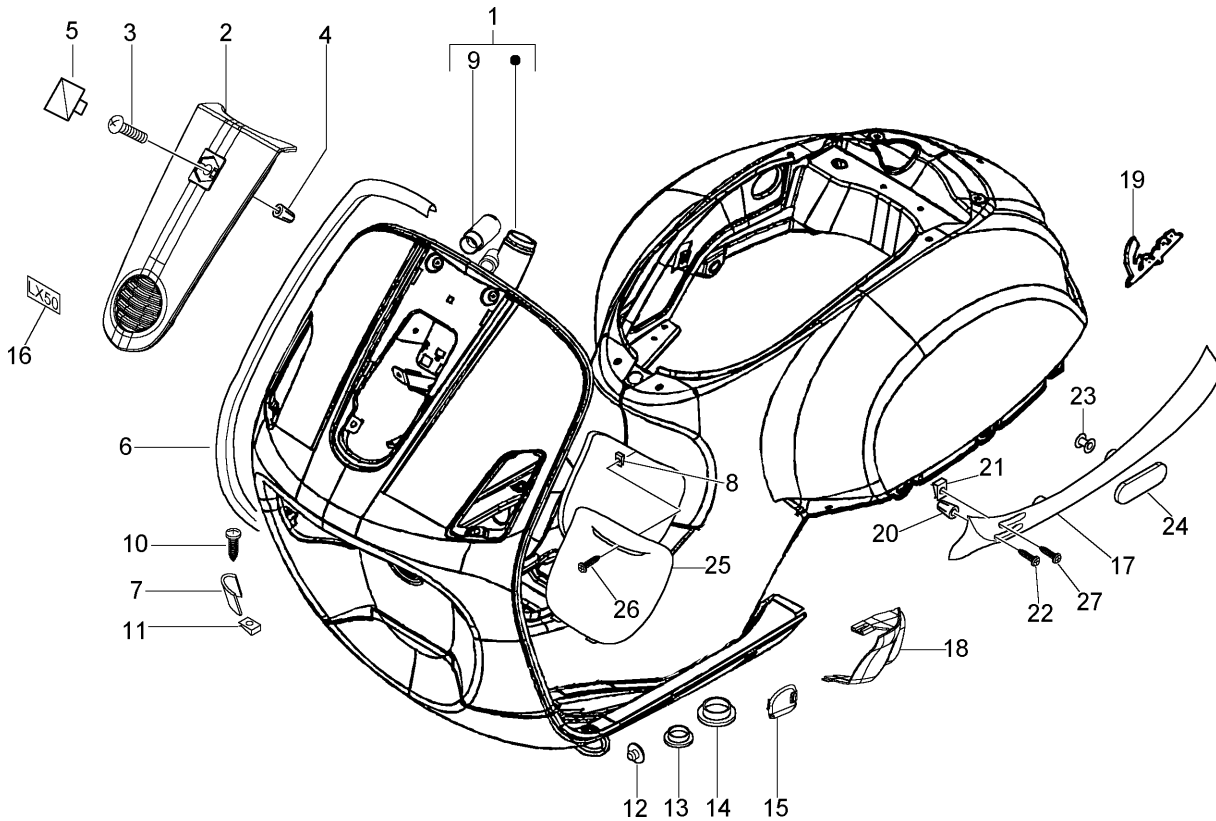

Pos. Pos. Loc. Pos. Pos.	Numero Número Number M.ge Número	Q.tà Q.té Q.ty M.ge Cant.	Nota Note Nota Anm. Nota	Denominazione	Désignation	Description	Beschreibung	Descripción
1	62211150F3	1	146	Scocca	Coque	Bodywork	Karosserie	Carrocería
1	62211150BM	1	525	Scocca	Coque	Bodywork	Karosserie	Carrocería
1	62211150F2	1	738/A	Scocca	Coque	Bodywork	Karosserie	Carrocería
1	62211150ND	1	79/A	Scocca	Coque	Bodywork	Karosserie	Carrocería
1	62211150R7	1	894	Scocca	Coque	Bodywork	Karosserie	Carrocería
2	62290750F3	1	146	Copristerzo	Cache-direction	Steering cover	Steuerrohrabdeckung	Cubre dirección
2	62290750BM	1	525	Copristerzo	Cache-direction	Steering cover	Steuerrohrabdeckung	Cubre dirección
2	62290750F2	1	738/A	Copristerzo	Cache-direction	Steering cover	Steuerrohrabdeckung	Cubre dirección
2	62290750ND	1	79/A	Copristerzo	Cache-direction	Steering cover	Steuerrohrabdeckung	Cubre dirección
2	62290750R7	1	894	Copristerzo	Cache-direction	Steering cover	Steuerrohrabdeckung	Cubre dirección
3	267958	1		Vite autof.	Vis taraud	Self tapp.screw	Schraube, Blech	Tornillo autorosc.
4	199190	1		Tassello	Taquet	Plate	Pfropfen	Taco
5	576464	1		Scudetto Piaggio	Ecusson Piaggio	Shield Piaggio	Schild Piaggio	Escudo Piaggio
6	622187	1	SX	Bordo scudo	Bordure de tableau	Windshield beading	Schlitzrohr	Recuadro escudo
6	622188	1	DX	Bordo scudo	Bordure de tableau	Windshield beading	Schlitzrohr	Recuadro escudo
7	299964	1	SX	Coprigiunto	Plaquette de fermeture	Tighteing flap	Lasche	Cubrejuntas
7	299965	1	DX	Coprigiunto	Plaquette de fermeture	Tighteing flap	Lasche	Cubrejuntas
8	CM017408	1		Piastrina	Plaquette	Plate	Plättchen	Placa



**SCocca
COQUE
BODYWORK
KAROSSERIE
CARROCERÍA**

T. 22

ZAPC 386B..5

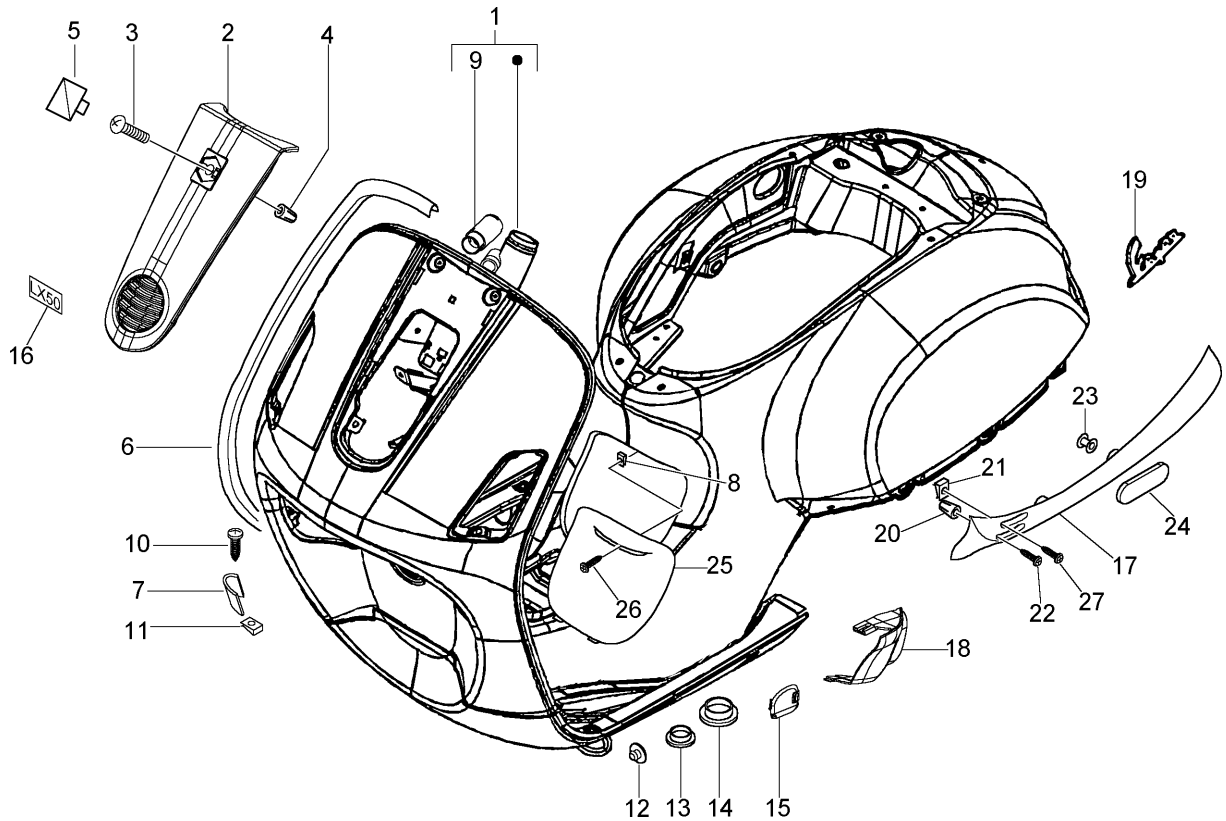

Pos. Pos. Loc. Pos. Pos.	Numero Número Number Number Número	Q.tà Q.té Q.ty M.ge Cant.	Nota Note Nota Anm. Nota	Denominazione	Désignation	Description	Beschreibung	Descripción
9	298604	1		Supporto serratura	Support	Bracket	Halter	Soporte
10	008432	2		Vite	Vis	Screw	Schraube	Tornillo
11	CM017405	2		Piastrina	Plaquette	Plate	Plättchen	Placa
12	299558	1		Tappo	Bouchon	Plug	Verschuß	Tapón
13	299557	2		Tappo	Bouchon	Plug	Verschuß	Tapón
14	299559	1		Tappo	Bouchon	Plug	Verschuß	Tapón
15	620556	2		Tappo	Bouchon	Plug	Verschuß	Tapón
17	62212740ND	1	SX-79/AFiancata	Carenage	Carenage	Fairing	Seitenverkleidung	Carenado
17	62212740BM	1	SX-525 Fiancata	Carenage	Carenage	Fairing	Seitenverkleidung	Carenado
17	62212740F2	1	SX-738/A Fiancata	Carenage	Carenage	Fairing	Seitenverkleidung	Carenado
17	62212740R7	1	SX-894 Fiancata	Carenage	Carenage	Fairing	Seitenverkleidung	Carenado
17	62212740F3	1	SX-146 Fiancata	Carenage	Carenage	Fairing	Seitenverkleidung	Carenado
17	62212840ND	1	DX-79/AFiancata	Carenage	Carenage	Fairing	Seitenverkleidung	Carenado
17	62212840BM	1	DX-525 Fiancata	Carenage	Carenage	Fairing	Seitenverkleidung	Carenado
17	62212840F2	1	DX-738/A Fiancata	Carenage	Carenage	Fairing	Seitenverkleidung	Carenado
17	62212840R7	1	DX-894 Fiancata	Carenage	Carenage	Fairing	Seitenverkleidung	Carenado
17	62212840F3	1	DX-146 Fiancata	Carenage	Carenage	Fairing	Seitenverkleidung	Carenado
18	62212940F3	1	SX-146 Terminale	Embout	Embout	Nipple	Nippel	Terminal
18	62212940BM	1	SX-525 Terminale	Embout	Embout	Nipple	Nippel	Terminal
18	62212940F2	1	SX-738/A Terminale	Embout	Embout	Nipple	Nippel	Terminal



**SCocca
COQUE
BODYWORK
KAROSSERIE
CARROCEÍA**

T. 22

ZAPC 386B..5

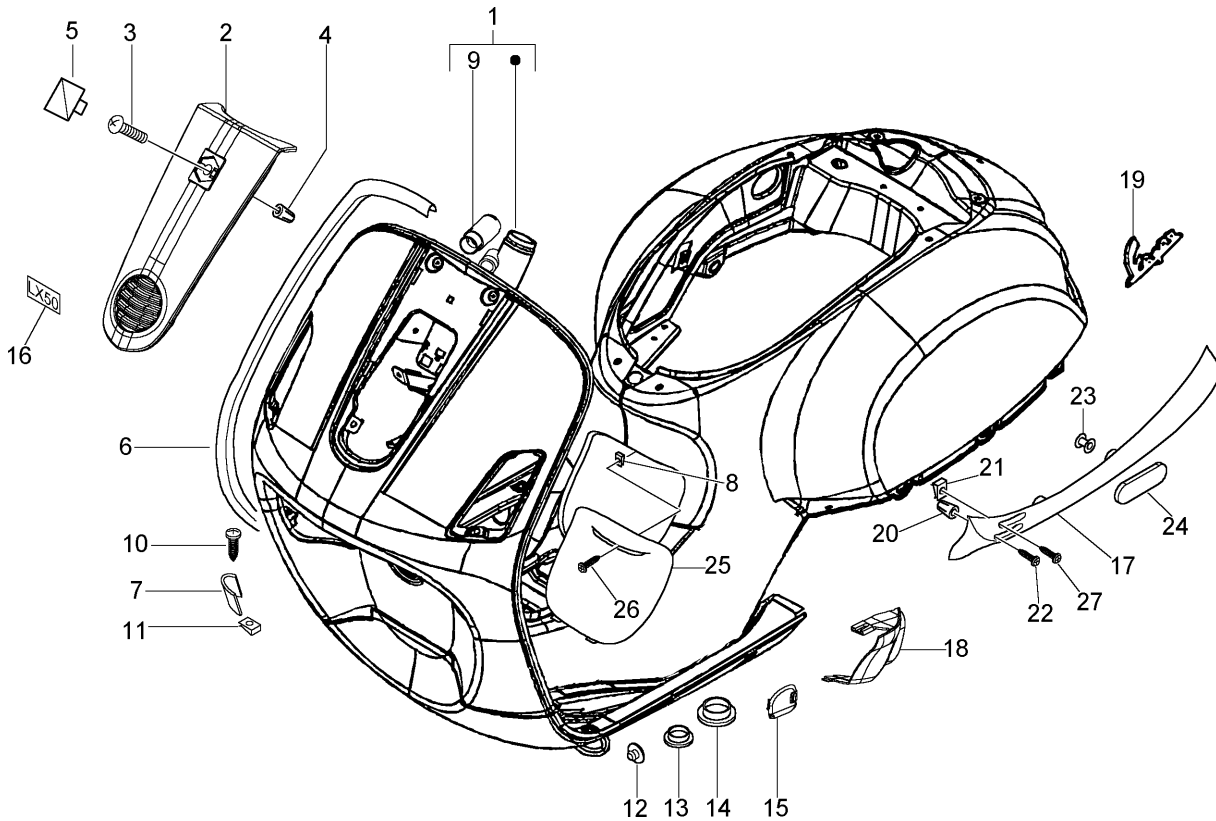

Pos. Pos. Loc. Pos. Pos.	Numero Número Number Nummer Número	Q.tà Q.té Q.ty M.ge Cant.	Nota Note Nota Anm. Nota	Denominazione	Désignation	Description	Beschreibung	Descripción
18	62212940ND	1	SX-79/A	Terminale	Embout	Nipple	Nippel	Terminal
18	62212940R7	1	SX-894	Terminale	Embout	Nipple	Nippel	Terminal
18	62213040F3	1	DX-146	Terminale	Embout	Nipple	Nippel	Terminal
18	62213040BM	1	DX-525	Terminale	Embout	Nipple	Nippel	Terminal
18	62213040F2	1	DX-738/A	Terminale	Embout	Nipple	Nippel	Terminal
18	62213040ND	1	DX-79/A	Terminale	Embout	Nipple	Nippel	Terminal
18	62213040R7	1	DX-894	Terminale	Embout	Nipple	Nippel	Terminal
19	620529	1		Targhetta "VESPA"	Monogramme "Vespa"	Vespa name plate	Vespa Plakette	Letrero "Vespa"
20	199190	4		Tassello	Taquet	Plate	Pfropfen	Taco
21	CM017410	2		Piastrina	Plaquette	Plate	Plättchen	Placa
22	259349	6		Vite	Vis	Screw	Schraube	Tornillo
23	463195	8		Tampone	Silentbloc	Buffer	Puffer	Silent-block
24	584925	2	DX	Catadiottro	Catadioptré	Reflector	Rückstrahler	Catafaro
24	584926	2	SX	Catadiottro	Catadioptré	Reflector	Rückstrahler	Catafaro
25	62213650F3	1	146	Portello	Abattant	Flap	Klappe	Registro
25	62213650BM	1	525	Portello	Abattant	Flap	Klappe	Registro
25	62213650F2	1	738/A	Portello	Abattant	Flap	Klappe	Registro
25	62213650ND	1	79/A	Portello	Abattant	Flap	Klappe	Registro
25	62213650R7	1	894	Portello	Abattant	Flap	Klappe	Registro
26	015911	1		Vite	Vis	Screw	Schraube	Tornillo



SCocca
COQUE
BODYWORK
KAROSSERIE
CARROCERÍA

T. 22

ZAPC 386B..5

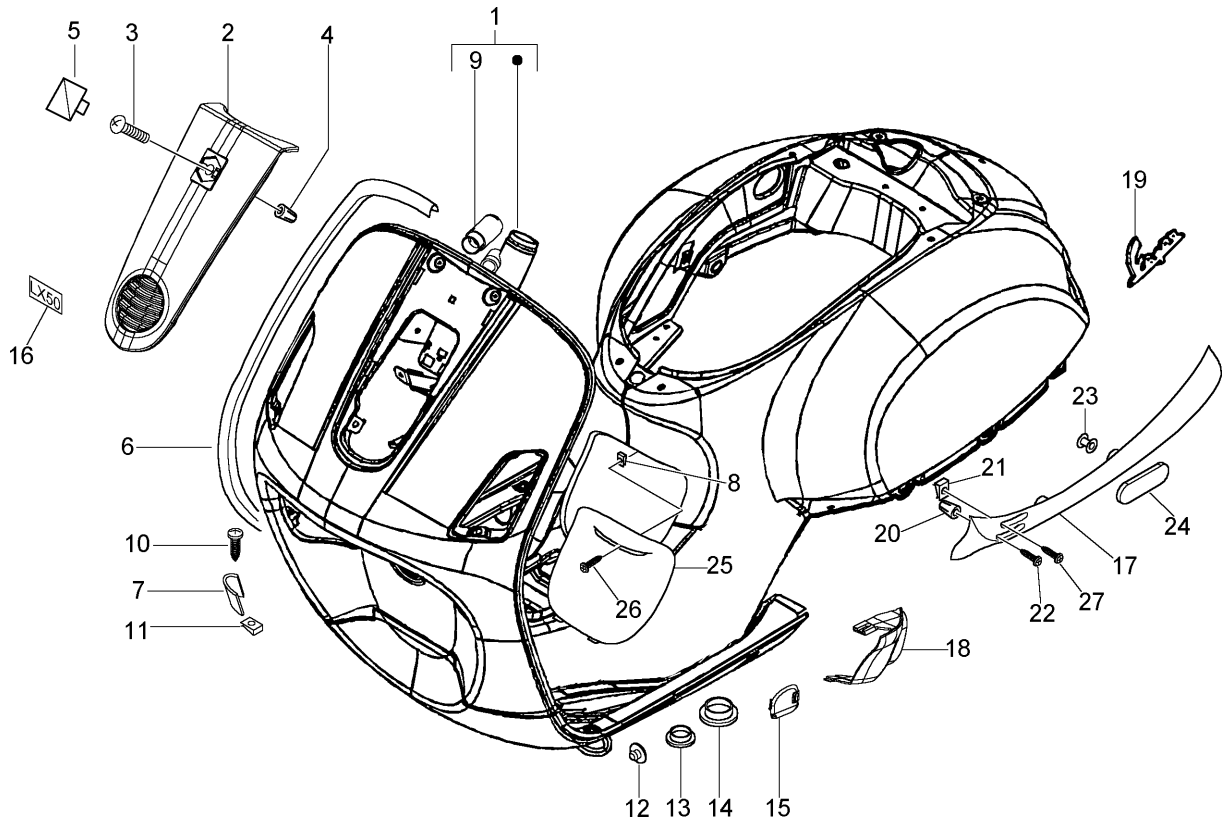

Pos. Pos. Loc. Pos. Pos.	Numero Número Number Nummer Número	Q.tà Q.té Q.ty M.ge Cant.	Nota Note Nota Anm. Nota	Denominazione	Désignation	Description	Beschreibung	Descripción
27	297498	2		Vite	Vis	Screw	Schraube	Tornillo



**PEDANA - TAPPETINI
 MARCHEPIED - TAPIS
 FOOT BOARD - RUBBER MATS
 FUßRETT - FUßMATTE
 ESTRIBO - ALFOMBRILLAS**

T. 23

ZAPC 386B..5

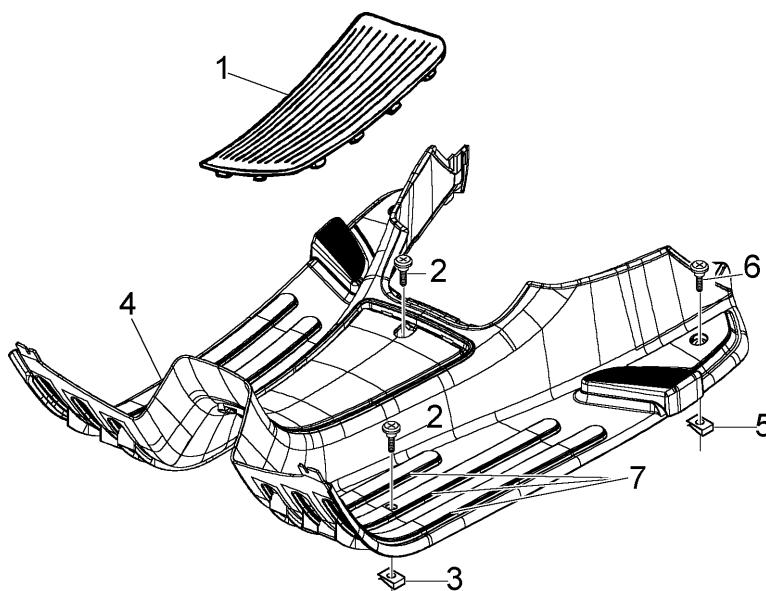

Pos. Pos. Loc. Pos. Pos.	Numero Número Number Nummer Número	Q.tà Q.té Q.ty M.ge Cant.	Nota Note Nota Anm. Nota	Denominazione	Désignation	Description	Beschreibung	Descripción
1	299236	1		Tappeto	Tapis	Mat	Fussmatte	Alfombrilla
2	576189	2		Vite	Vis	Screw	Schraube	Tornillo
3	CM017406	2		Piastrina	Plaquette	Plate	Plättchen	Placa
4	62212440ND	1	79/A	Pedana	Tapis	Rubber mat	Fußraumabdeckung	Estribo
4	62212440BM	1	525	Pedana	Tapis	Rubber mat	Fußraumabdeckung	Estribo
4	62212440F2	1	738/A	Pedana	Tapis	Rubber mat	Fußraumabdeckung	Estribo
4	62212440R7	1	894	Pedana	Tapis	Rubber mat	Fußraumabdeckung	Estribo
4	62212440F3	1	146	Pedana	Tapis	Rubber mat	Fußraumabdeckung	Estribo
5	254485	2		Piastrina	Plaquette	Plate	Plättchen	Placa
6	271891	2		Vite	Vis	Screw	Schraube	Tornillo
7	622139	1		Kit strisce	Kit bandes	Stripes kit	Streifen (satz)	Kit tiras



**BAULETTO ANTERIORE
COFFRE A L'AVANT
FRONT GLOVE COMPARTMENT
VORDERES GEPÄCKFACH
MALETA DELANTERA**

T. 24

ZAPC 386B..5

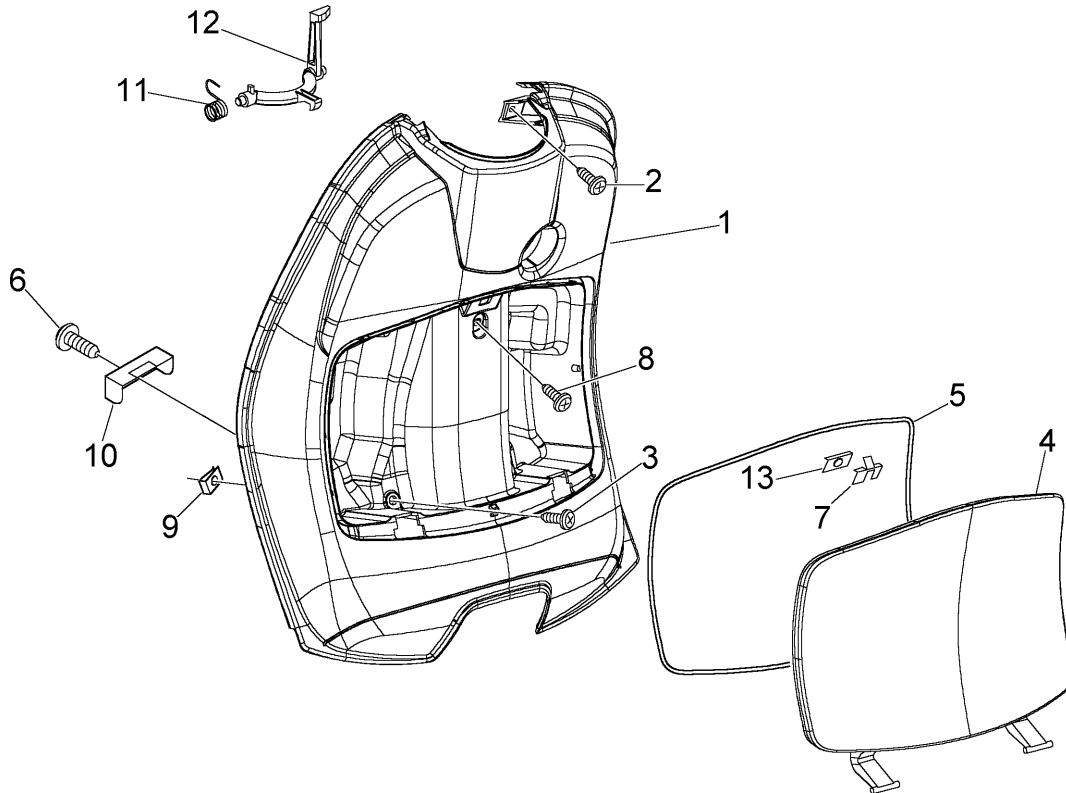

Pos. Pos. Loc. Pos. Pos.	Numero Número	Q.tà Q.té Q.ty M.ge Cant.	Nota Note Nota Anm. Nota	Denominazione	Désignation	Description	Beschreibung	Descripción
1	62217950ND	1	79/A	Bauletto anteriore	Coffre a l'av.	Fr. glove comp.	Gepäckfach vorne	Maleta del.
1	62217950BM	1	525	Bauletto anteriore	Coffre a l'av.	Fr. glove comp.	Gepäckfach vorne	Maleta del.
1	62217950F2	1	738/A	Bauletto anteriore	Coffre a l'av.	Fr. glove comp.	Gepäckfach vorne	Maleta del.
1	62217950R7	1	894	Bauletto anteriore	Coffre a l'av.	Fr. glove comp.	Gepäckfach vorne	Maleta del.
1	62217950F3	1	146	Bauletto anteriore	Coffre a l'av.	Fr. glove comp.	Gepäckfach vorne	Maleta del.
2	259830	2		Vite	Vis	Screw	Schraube	Tornillo
3	575249	2		Vite	Vis	Screw	Schraube	Tornillo
4	62211550ND	1	79/A	Portello	Abattant	Flap	Klappe	Registro
4	62211550BM	1	525	Portello	Abattant	Flap	Klappe	Registro
4	62211550F2	1	738/A	Portello	Abattant	Flap	Klappe	Registro
4	62211550R7	1	894	Portello	Abattant	Flap	Klappe	Registro
4	62211550F3	1	146	Portello	Abattant	Flap	Klappe	Registro
5	297275	1		Guarnizione	Joint	Packing	Dichtung	Junta
6	268596	4		Vite	Vis	Screw	Schraube	Tornillo
7	573057	1		Molletta	Ressort	Spring	Federklammer	Muelle
8	575249	1		Vite	Vis	Screw	Schraube	Tornillo
9	254485	4		Piastrina	Plaquette	Plate	Plättchen	Placa
10	257614	1		Squadretta	Equerre	Bracket	Halter	Escudrita
11	257617	1		Molla	Ressort	Spring	Feder	Muelle
12	295528	1		Gancio	Crochet	Hook	Haken	Gancho



**BAULETTO ANTERIORE
COFFRE A L'AVANT
FRONT GLOVE COMPARTMENT
VORDERES GEPÄCKFACH
MALETA DELANTERA**

T. 24

ZAPC 386B..5

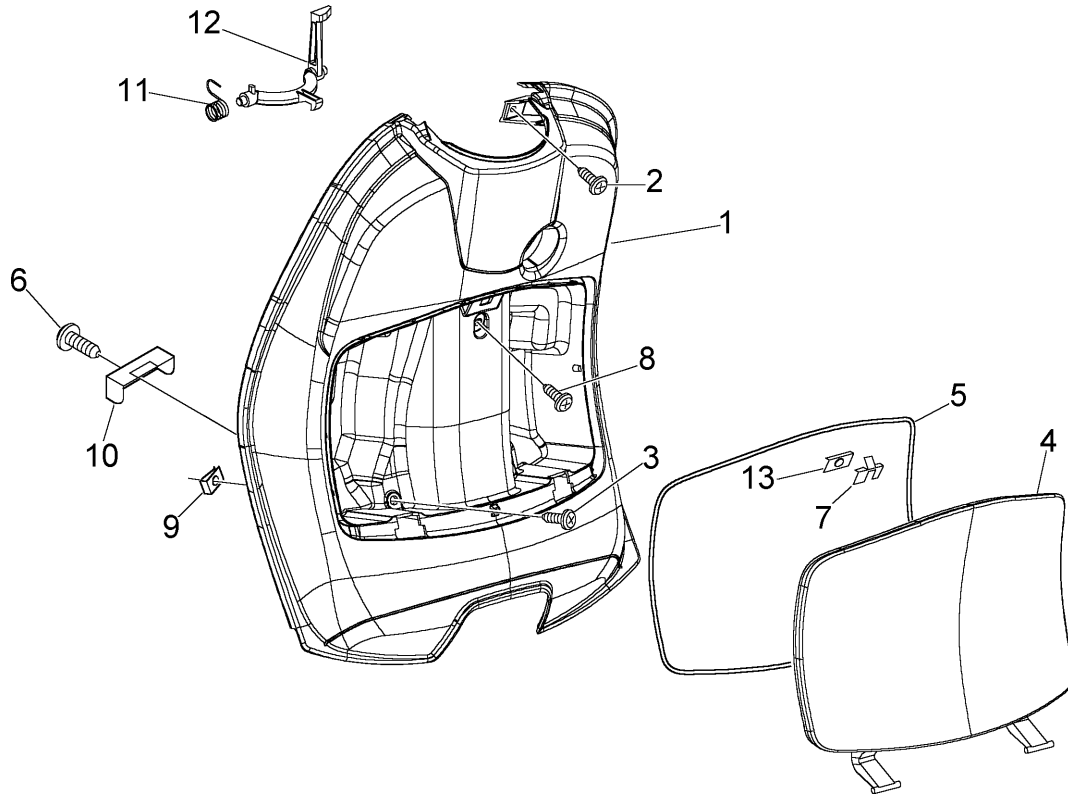

Pos. Pos. Loc. Pos. Pos.	Numero Numéro Number Nummer Número	Q.tà Q.té Q.ty M.ge Cant.	Nota Note Nota Anm. Nota	Denominazione	Désignation	Description	Beschreibung	Descripción
13	252420	1		Squadretta	Equerre	Bracket	Halter	Escuadrita



**SERBATOIO CARBURANTE
RESERVOIR
FUEL TANK
KRAFTSTOFFTANK
DEPOSITO CARBURANTE**

T. 25

ZAPC 386B..5

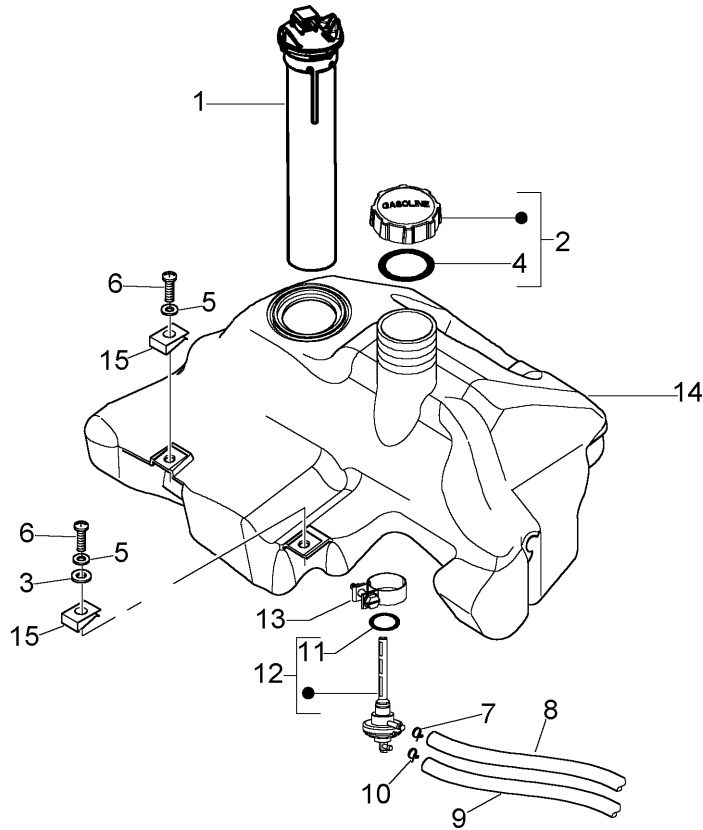

Pos. Pos. Loc. Pos. Pos.	Numero Número	Q.tà Q.té Q.ty M.ge Cant.	Nota Note Nota Anm. Nota	Denominazione	Désignation	Description	Beschreibung	Descripción
1	CM025702	1		Indicatore livello	Jauge	Level gauge	Kraftstoffanzeige	Indicador de nivel
2	259832	1		Tappo serb.	Bouch.voy.h.	Oil ins.pl.	Tankverschluss	Tapa d.ac.
3	013880	1		Rondella	Rondelle	Washer	U.Scheibe	Arandela
4	258160	1		Guarnizione	Joint	Packing	Dichtung	Junta
5	016406	3		Rondella	Rondelle	Washer	U.Scheibe	Arandela
6	015759	3		Vite	Vis	Screw	Schraube	Tornillo
7	CM002904	1		Fascetta	Collier	Clamp	Schelle	Abrazadera
8	CM001209	1		Tubo	Tuyau	Tube	Schlauch	Tubo
9	CM006102	1		Tubo sfiato	Tuyau réinflard	Breather tube	Entlüftungsleitung	Tubo respiradero
10	CM002901	1		Fascetta	Collier	Clamp	Schelle	Abrazadera
11	196868	1		Guarnizione	Joint	Packing	Dichtung	Junta
12	575321	1		Rubinetto	Robinet	Fuel tap	Kraftstoffhahn.	Grifo
13	577557	1		Fascetta	Collier	Clamp	Schelle	Abrazadera
14	622834	1		Serbatoio	Réservoir	Tank	Tank	Deposito
15	254485	3		Piastrina	Plaquette	Plate	Plättchen	Placa



**PORTACASCO
PORTE CASQUE
CASE HELMET
SCHUTZHELMTRÄGER
PORTA CASCO**

T. 26

ZAPC 386B..5

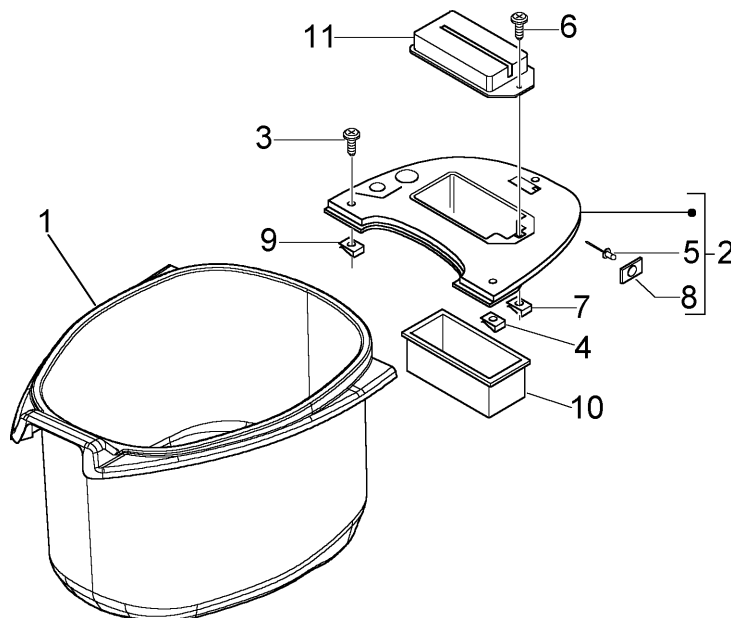

Pos. Pos. Loc. Pos. Pos.	Numero Número Number Nummer Número	Q.tà Q.té Q.ty M.ge Cant.	Nota Note Nota Anm. Nota	Denominazione	Désignation	Description	Beschreibung	Descripción
1	622131	1		Portacasco	Porte-casque	Case-helmet	Sturzhelmbehälter	Porta-casco
2	623020	1		Copertura	Couvercle	Cover	Abdeckung	Cubierta
3	259372	4		Vite	Vis	Screw	Schraube	Tornillo
4	254485	2		Piastrina	Plaquette	Plate	Plättchen	Placa
5	182302	1		Rivetto	Rivet	Rivet	Niete	Remache
6	576189	1		Vite	Vis	Screw	Schraube	Tornillo
7	CM017410	3		Piastrina	Plaquette	Plate	Plättchen	Placa
8	290405	1		Basetta	Support	Bracket	Halter	Soporte
9	CM017408	2		Piastrina	Plaquette	Plate	Plättchen	Placa
10	299047	1		Vaschetta	Cuvette	Float ch.	Schwimmergehäuse	Cuba
11	576017	1		Portello	Abattant	Flap	Klappe	Registro



**SELLA
SELLE
SADDLE
SÄTTEL
SILLIN**

T. 27

ZAPC 386B..5

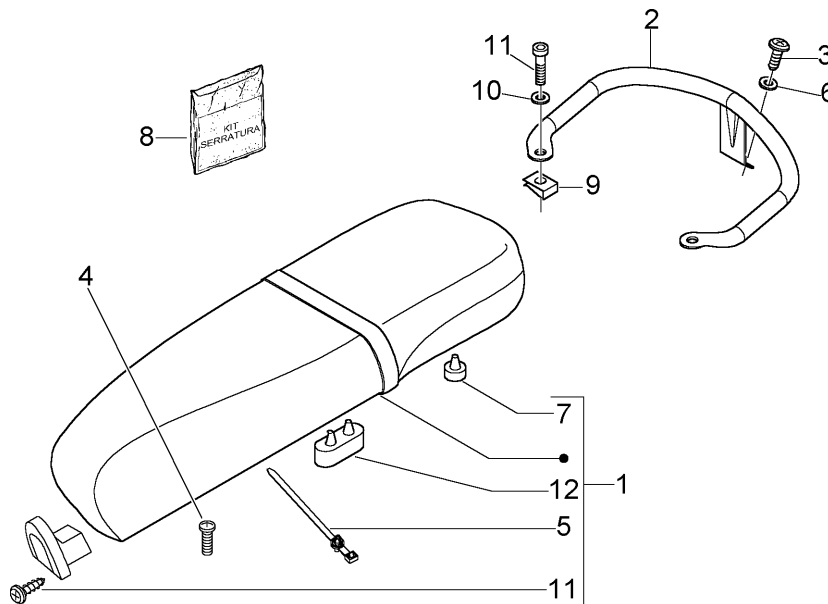

Pos. Pos. Loc. Pos. Pos.	Numero Número	Q.tà Q.té Q.ty M.ge Cant.	Nota Note Nota Anm. Nota	Denominazione	Désignation	Description	Beschreibung	Descripción
1	CM02520100E8	1	MR	Sella	Selle	Saddle	Sitzbank	Sillín
1	CM02520100E9	1	N	Sella	Selle	Saddle	Sitzbank	Sillín
2	623572	1		Maniglia	Poignée	Grip	Klinke	Manilla
3	319538	2		Vite	Vis	Screw	Schraube	Tornillo
4	259830	2		Vite	Vis	Screw	Schraube	Tornillo
5	298729	1		Fascetta	Collier	Clamp	Schelle	Abrazadera
6	006966	2		Rondella	Rondelle	Washer	U.Scheibe	Arandela
7	577492	2		Tampone	Silentbloc	Buffer	Puffer	Silent-block
8	494511	1		Gr. serratura	Ens.serrure	Lock,assy	Schloßsatz	KIT cerradura
9	254485	1		Piastrina	Plaquette	Plate	Plättchen	Placa
10	013880	2		Rondella	Rondelle	Washer	U.Scheibe	Arandela
11	272836	2		Vite	Vis	Screw	Schraube	Tornillo
12	296456	2		Tampone	Silentbloc	Buffer	Puffer	Silent-block



**PARAFANGO ANT. E POST.
GARDE BOUE AV. ET AR.
FRONT AND REAR MUDGUARD
VORDERKOTFLÜGEL - HINTERKOTFLÜGEL
GUARDABARROS DEL. Y TRAS.**

T. 28

ZAPC 386B..5

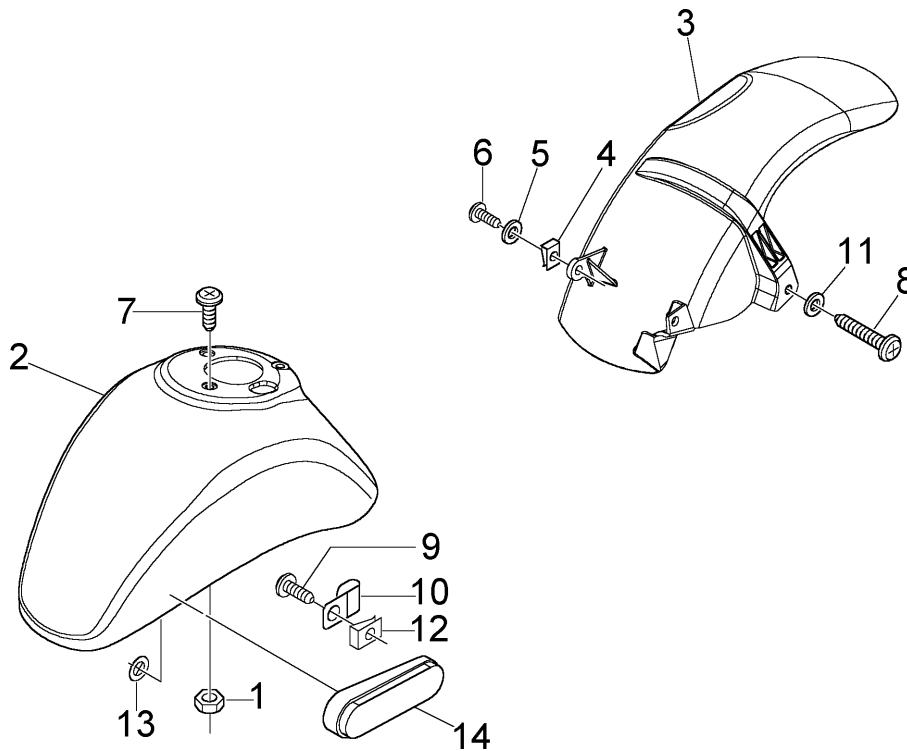

Pos. Pos. Loc. Pos. Pos.	Numero Numéro Number Nummer Número	Q.tà Q.té Q.ty M.ge Cant.	Nota Note Nota Anm. Nota	Denominazione	Désignation	Description	Beschreibung	Descripción
1	288245	3		Dado	Ecrou	Nut	Mutter	Tuerca
2	60041540F3	1	146	Parafango	Garde -boue	Mudguard	Kotflügel	Guardabarros
2	60041540BM	1	525	Parafango	Garde -boue	Mudguard	Kotflügel	Guardabarros
2	60041540F2	1	738/A	Parafango	Garde -boue	Mudguard	Kotflügel	Guardabarros
2	60041540ND	1	79/A	Parafango	Garde -boue	Mudguard	Kotflügel	Guardabarros
2	60041540R7	1	894	Parafango	Garde -boue	Mudguard	Kotflügel	Guardabarros
3	575079	1		Parafango post.	Garde-boue AR.	Rear mudguard	Hinterradkotflügel	Guardabarros tras.
4	254485	2		Piastrina	Plaquette	Plate	Plättchen	Placa
5	012533	2		Rondella	Rondelle	Washer	U.Scheibe	Arandela
6	575249	1		Vite	Vis	Screw	Schraube	Tornillo
7	575249	3		Vite	Vis	Screw	Schraube	Tornillo
8	015804	1		Vite	Vis	Screw	Schraube	Tornillo
9	015900	1		Vite	Vis	Screw	Schraube	Tornillo
10	562919	1		Fascetta	Collier	Clamp	Schelle	Abrazadera
11	013880	1		Rondella	Rondelle	Washer	U.Scheibe	Arandela
12	CM017410	1		Piastrina	Plaquette	Plate	Plättchen	Placa
13	181351	4		Piastrina	Plaquette	Plate	Plättchen	Placa
14	584084	1	DX	Catadiottro	Catadioptré	Reflector	Rückstrahler	Catafaro
14	584083	1	SX	Catadiottro	Catadioptré	Reflector	Rückstrahler	Catafaro



STERZO - FRENO A DISCO
TUBE DE DIRECTION - FREIN À DISQUE
STEERING COLUMN - DISC BRAKE
STEUERROHR - SCHEIBENBREMSE
TUBO DE DIRECCION - FRENO DE DISCO

T. 29

ZAPC 386B..5

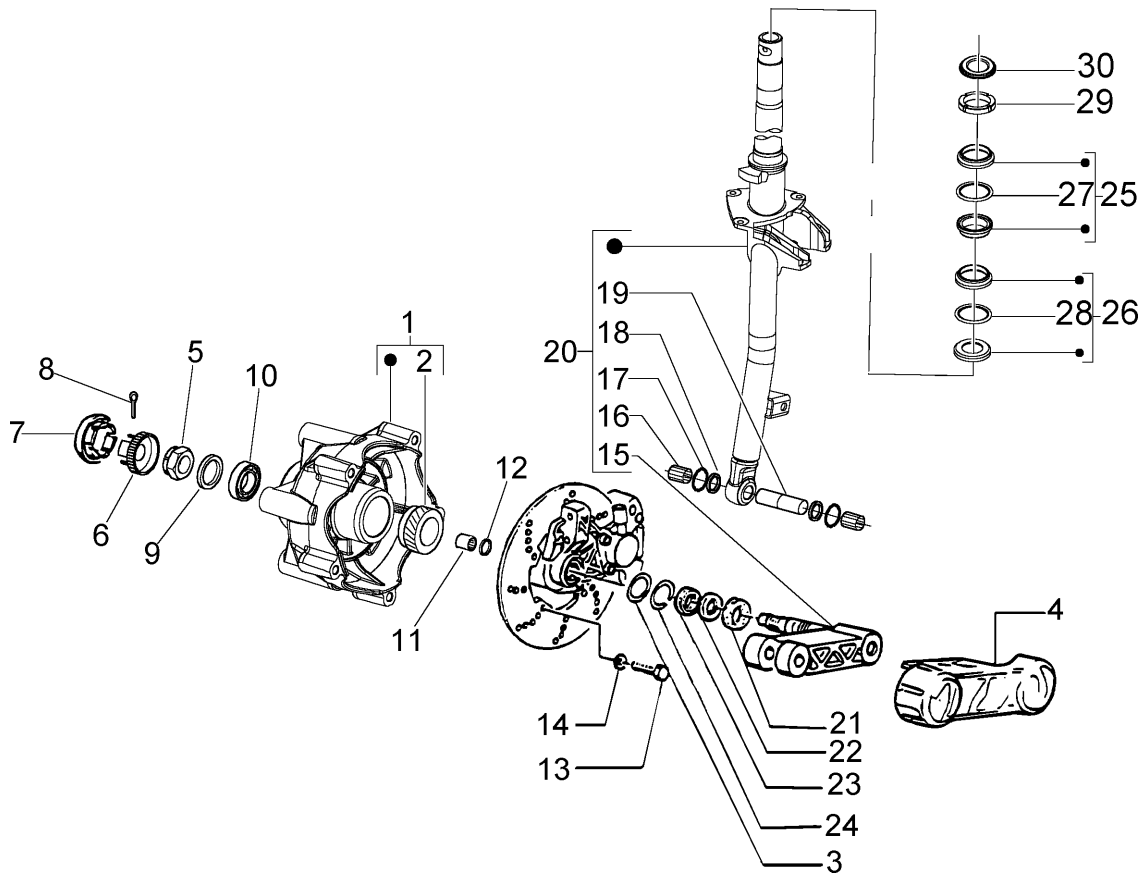

Pos. Pos. Loc. Pos. Pos.	Numero Número	Q.tà Q.té Q.ty M.ge Cant.	Nota Note Nota Anm. Nota	Denominazione	Désignation	Description	Beschreibung	Descrición
1	560284	1		Mozzo	Moyeu	Hub	Nabe	Buje
2	267818	1		Corona dentata	Couronne dentée	Ring gear	Zahnrad	Corona dentada
3	177414	1		Rondella	Rondelle	Washer	U.Scheibe	Arandela
4	561433	1		Protezione	Protection	Protection	Schutzstück	Protección
5	021114	1		Dado	Ecrou	Nut	Mutter	Tuerca
6	177609	1		Cappello	Cache	Cap	Kappe	Capuchón
7	092517	1		Tappo	Bouchon	Plug	Verschluß	Tapón
8	012789	1		Coppiglia	Goupille	Split pin	Splint	Grupilla
9	006635	1		Anello	Circlips	Ring	Ring	Anillo
10	177610	1		Cuscinetto	Roulement	Bearing	Lager	Cojinete
11	177442	1		Astuccio	Douille	Drawn cap	Büchse	Casquillo
12	177443	1		Anello	Circlips	Ring	Ring	Anillo
13	271147	5		Vite	Vis	Screw	Schraube	Tornillo
14	006966	5		Rondella	Rondelle	Washer	U.Scheibe	Arandela
15	56140R5	1		Braccio sosp.	Bras. de la susp.	Suspension arm	Schwingarm	Brazo suspensión
16	198513	2		Astuccio	Douille	Drawn cap	Büchse	Casquillo
17	006731	2		Guarnizione	Joint	Packing	Dichtung	Junta
18	119219	2		Anello ten.	Joint spie	Oil seal	Dichtring	Reten de ac.
19	177451	1		Spinotto	Axe	Pin	Zapfen	Eje



STERZO - FRENO A DISCO
TUBE DE DIRECTION - FREIN À DISQUE
STEERING COLUMN - DISC BRAKE
STEUERROHR - SCHEIBENBREMSE
TUBO DE DIRECCION - FRENO DE DISCO

T. 29

ZAPC 386B..5

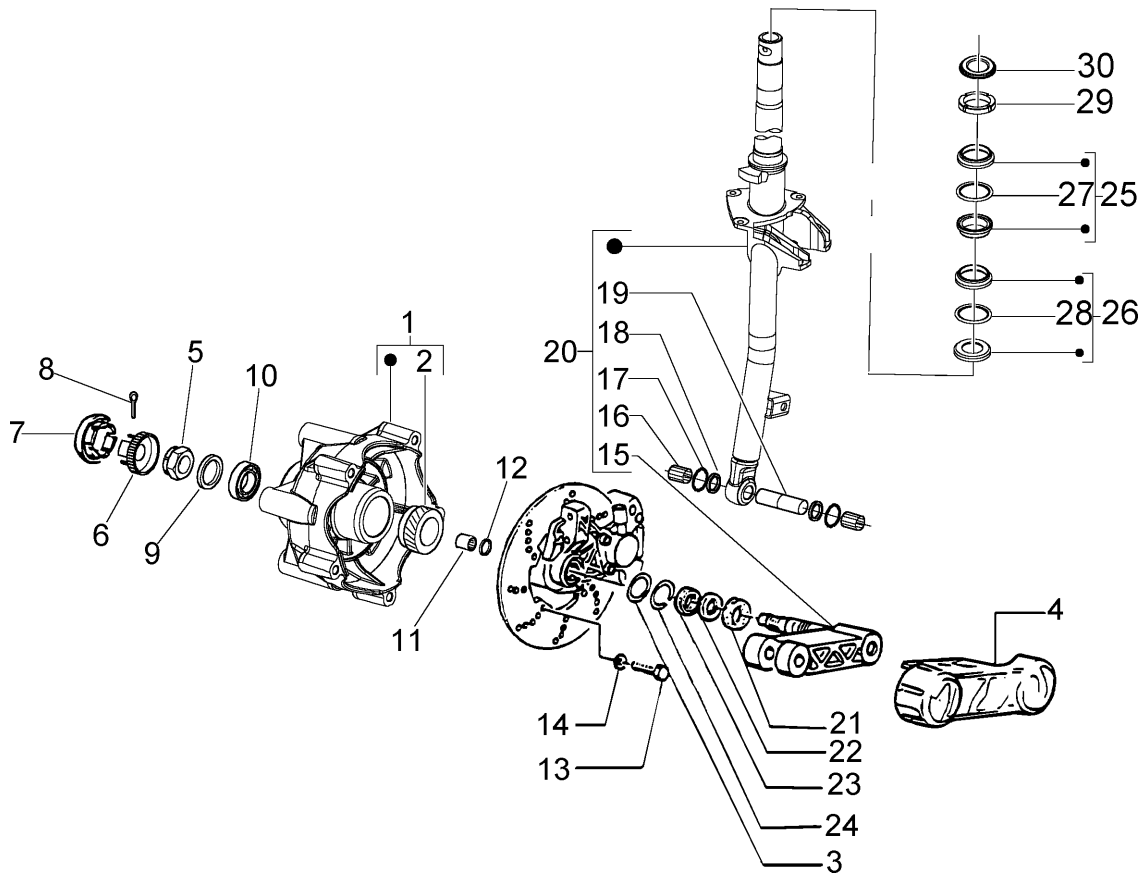

Pos. Pos. Loc. Pos. Pos.	Numero Número	Q.tà Q.té Q.ty M.ge Cant.	Nota Note Nota Anm. Nota	Denominazione	Désignation	Description	Beschreibung	Descripción
20	6011825	1		Tubo sterzo	Tuyau de direction	Steer.column	Steuerrohr	Tubo de dir.
21	177408	1		Anello	Circlips	Ring	Ring	Anillo
22	177445	1		Rondella	Rondelle	Washer	U.Scheibe	Arandela
23	177521	1		Anello	Circlips	Ring	Ring	Anillo
24	006422	1		Anello	Circlips	Ring	Ring	Anillo
25	56002R	1		Gruppo ralle	Gr. but. dir.	Steering bearing assy.	Steuersatz	Gr. coj. de dir.
26	56003R	1		Gruppo ralle	Gr. but. dir.	Steering bearing assy.	Steuersatz	Gr. coj. de dir.
27	077024	1	B	Gabbia a sfere	Cage à billes	Ball cage	Kugelkäfig	Jaula de bolas
27	564257	1	G	Gabbia a sfere	Cage à billes	Ball cage	Kugelkäfig	Jaula de bolas
28	077023	1	B	Gabbia a sfere	Cage à billes	Ball cage	Kugelkäfig	Jaula de bolas
28	564260	1	G	Gabbia a sfere	Cage à billes	Ball cage	Kugelkäfig	Jaula de bolas
29	011109	1		Ghiera	Douille	Ring nut	Gewinding	Casquillo
30	003751	1		Rondella	Rondelle	Washer	U.Scheibe	Arandela



**PINZA FRENO A DISCO
ETRIER FREIN A DISQUE
DISC BRAKE CALIPER
BREMSZANGE - SCHEIBE
PINZA FRENO DE DISCO**

T. 30

ZAPC 386B..5

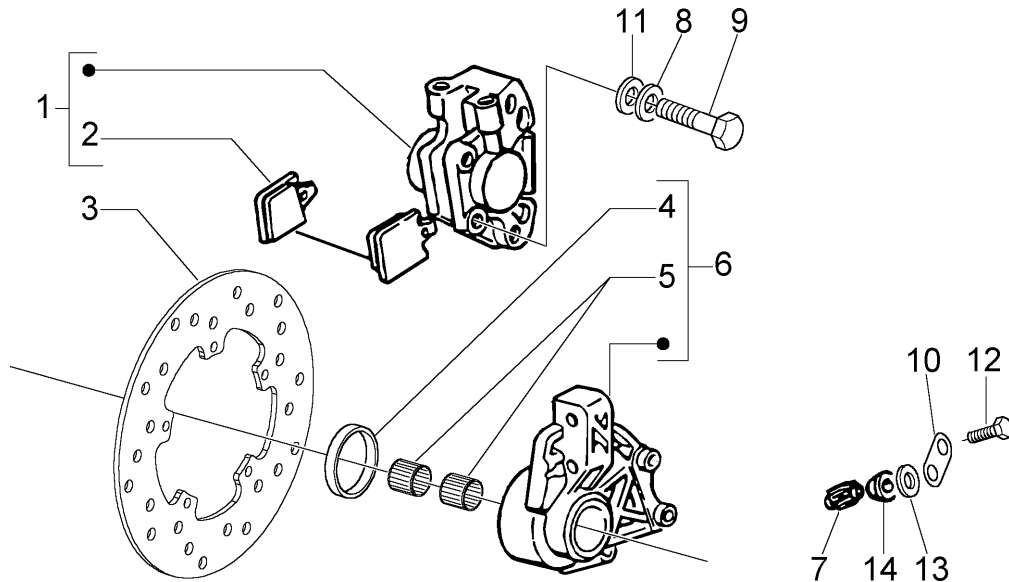

Pos. Pos. Loc. Pos. Pos.	Numero Número Number Nummer Número	Q.tà Q.té Q.ty M.ge Cant.	Nota Note Nota Anm. Nota	Denominazione	Désignation	Description	Beschreibung	Descripción
1	CM076101	1		Pinza freno	Etrier de frein	Caliper	Bremszange	Pinza del freno
2	494097	1	GRM	Kit pasticche freno	Jeu plaquettes freins	Brake pads kit	Bremsklötze	Juego pastillas freno
2	494097	1	HT	Kit pasticche freno	Jeu plaquettes freins	Brake pads kit	Bremsklötze	Juego pastillas freno
3	563246	1		Disco freno	Disque frein	Brake plate	Bremscheibe	Disco freno
4	177494	1		Anello	Circlips	Ring	Ring	Anillo
5	177436	2		Astuccio	Douille	Drawn cap	Büchse	Casquillo
6	5602865	1		Supporto	Support	Bracket	Halter	Soporte
7	267819	1		Rocchetto	Pignon	Pinion	Ritzel	Piñón
8	003058	1		Rondella	Rondelle	Washer	U.Scheibe	Arandela
9	597150	2		Vite	Vis	Screw	Schraube	Tornillo
10	269118	1		Piastrina	Plaquette	Plate	Plättchen	Placa
11	709047	4		Rondella	Rondelle	Washer	U.Scheibe	Arandela
12	031058	1		Bulloncino	Boulon	Screw	Bolzen	Tornillo
13	266841	1		Tampone	Silentbloc	Buffer	Puffer	Silent-block
14	564053	1		Supporto	Support	Bracket	Halter	Soporte



COPERTURA AMMORTIZZATORE ANTERIORE
COUVERTURE AMORTISSEUR AV.
FRONT DAMPER COVER
ABDECKUNG VORDERER STOßDAMPFER
CUBIERTA AMORTIGUADOR DELANTERO

T. 31

ZAPC 386B..5

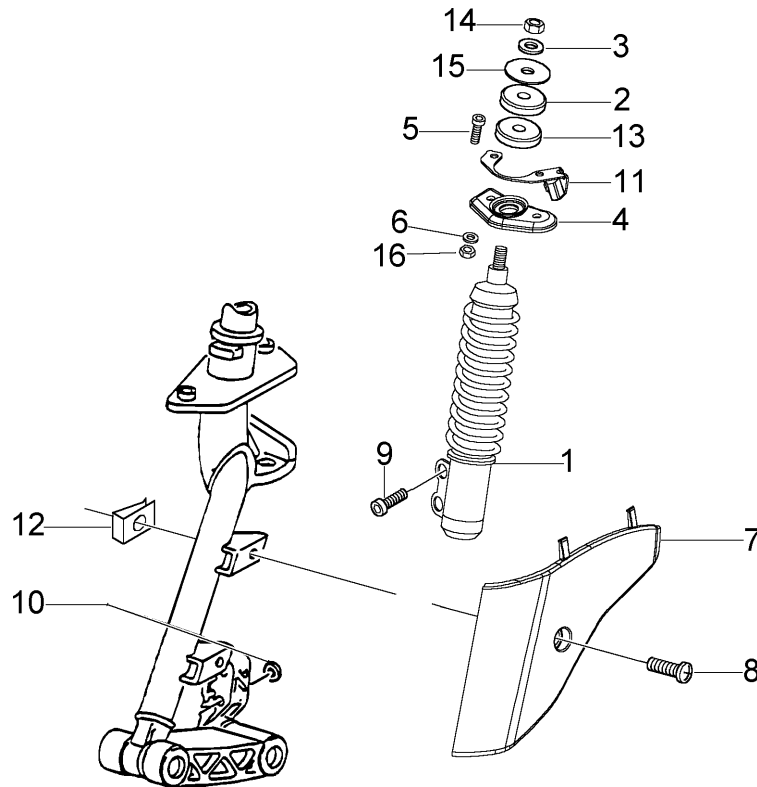

Pos. Pos. Loc. Pos. Pos.	Numero Numéro Number Nummer Número	Q.tà Q.té Q.ty M.ge Cant.	Nota Note Nota Anm. Nota	Denominazione	Désignation	Description	Beschreibung	Descripción
1	56222R	1		Ammortizzatore	Amortisseur	Damper	Stoßdämpfer	Amortiguador
2	174874	1		Tampone	Silentbloc	Buffer	Puffer	Silent-block
3	012535	1		Rondella	Rondelle	Washer	U.Scheibe	Arandela
4	273693	1		Mensola	Support	Bracket	Halter	Soporte
5	031120	2		Bullone	Boulon	Bolt	Bolzen	Tornillo
7	60041640BM	1	525	Copertura	Couvercle	Cover	Abdeckung	Cubierta
7	60041640F2	1	738/A	Copertura	Couvercle	Cover	Abdeckung	Cubierta
7	60041640ND	1	79/A	Copertura	Couvercle	Cover	Abdeckung	Cubierta
7	60041640R7	1	894	Copertura	Couvercle	Cover	Abdeckung	Cubierta
7	60041640F3	1	146	Copertura	Couvercle	Cover	Abdeckung	Cubierta
8	575249	1		Vite	Vis	Screw	Schraube	Tornillo
9	149104	2		Vite	Vis	Screw	Schraube	Tornillo
10	016408	2		Rondella	Rondelle	Washer	U.Scheibe	Arandela
11	601610	1		Staffa	Support	Bracket	Halterung	Soporte
12	254485	1		Piastrina	Plaque	Plate	Plättchen	Placa
13	174085	1		Tampone	Silentbloc	Buffer	Puffer	Silent-block
14	021210	1		Dado	Ecrou	Nut	Mutter	Tuerca
15	174088	1		Rondella	Rondelle	Washer	U.Scheibe	Arandela
16	020108	2		Dado	Ecrou	Nut	Mutter	Tuerca



AMMORTIZZATORE POSTERIORE
AMORTISSEUR AR.
REAR DAMPER
HINTERER STOßDAMPFER
AMORTIGUADOR TRASERO

T. 32

ZAPC 386B..5

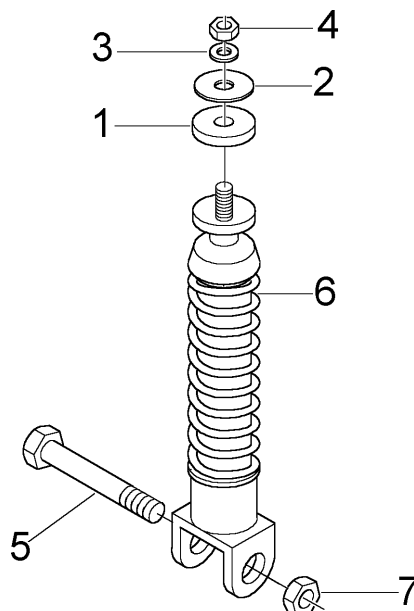

Pos. Pos. Loc. Pos. Pos.	Numero Número	Q.tà Q.té Q.ty M.ge Cant.	Nota Note Nota Anm. Nota	Denominazione	Désignation	Description	Beschreibung	Descripción
1	178150	1		Tampone sup.	Silentbloc sup.	Upper buffer	Puffer o.	Silent-block sup.
2	267038	1		Rondella	Rondelle	Washer	U.Scheibe	Arandela
3	016408	1		Rondella	Rondelle	Washer	U.Scheibe	Arandela
4	021108	1		Dado	Ecrou	Nut	Mutter	Tuerca
5	268158	1		Vite	Vis	Screw	Schraube	Tornillo
6	600488	1		Ammortizzatore post.	Amortisseur AR.	Rear damper	Stossdämpfer hinten	Amortig. trasero
7	232108	1		Dado	Ecrou	Nut	Mutter	Tuerca



CONTACHILOMETRI - COPERCHI MANUBRIO
COMPTEUR KILOMETRIQUE - COUVERCLES DU GUIDON
SPEEDOMETER KMS. - HANDLEBAR COVERS
TACHOMETER - LENKERDECKEL
CUENTAKM. - TAPAS MANILLAR

T. 33

ZAPC 386B..5

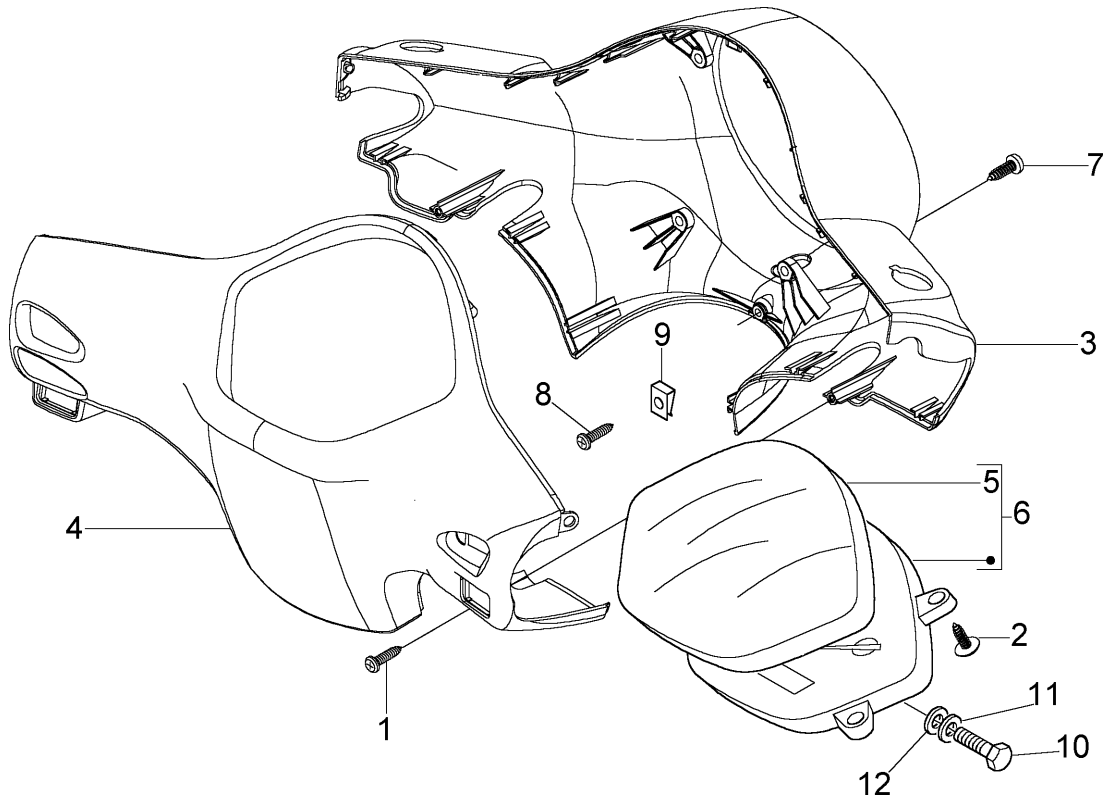

Pos. Pos. Loc. Pos. Pos.	Numero Numéro Number Nummer Número	Q.tà Q.té Q.ty M.ge Cant.	Nota Note Nota Anm. Nota	Denominazione	Désignation	Description	Beschreibung	Descripción
1	258146	2		Vite	Vis	Screw	Schraube	Tornillo
2	270793	4		Vite	Vis	Screw	Schraube	Tornillo
3	62218940F3	1	146	Coprimanubrio ant.	Cache direction AV.	Front handlebars cover	Lenkerdeckel vorderer	Cubre manillar del.
3	62218940BM	1	525	Coprimanubrio ant.	Cache direction AV.	Front handlebars cover	Lenkerdeckel vorderer	Cubre manillar del.
3	62218940F2	1	738/A	Coprimanubrio ant.	Cache direction AV.	Front handlebars cover	Lenkerdeckel vorderer	Cubre manillar del.
3	62218940ND	1	79/A	Coprimanubrio ant.	Cache direction AV.	Front handlebars cover	Lenkerdeckel vorderer	Cubre manillar del.
3	62218940R7	1	894	Coprimanubrio ant.	Cache direction AV.	Front handlebars cover	Lenkerdeckel vorderer	Cubre manillar del.
4	62219040ND	1	79/A	Coprimanubrio posteriore	Cache direction AR.	Rear handlebars cover	Lenkerdeckel hinterer	Cubre manillar tras.
4	62219040D9	1	204/A	Coprimanubrio posteriore	Cache direction AR.	Rear handlebars cover	Lenkerdeckel hinterer	Cubre manillar tras.
4	62219040F3	1	146	Coprimanubrio posteriore	Cache direction AR.	Rear handlebars cover	Lenkerdeckel hinterer	Cubre manillar tras.
4	62219040BM	1	525	Coprimanubrio posteriore	Cache direction AR.	Rear handlebars cover	Lenkerdeckel hinterer	Cubre manillar tras.



CONTACHILOMETRI - COPERCHI MANUBRIO
COMPTEUR KILOMETRIQUE - COUVERCLES DU GUIDON
SPEEDOMETER KMS. - HANDLEBAR COVERS
TACHOMETER - LENKERDECKEL
CUENTAKM. - TAPAS MANILLAR

T. 33

ZAPC 386B..5

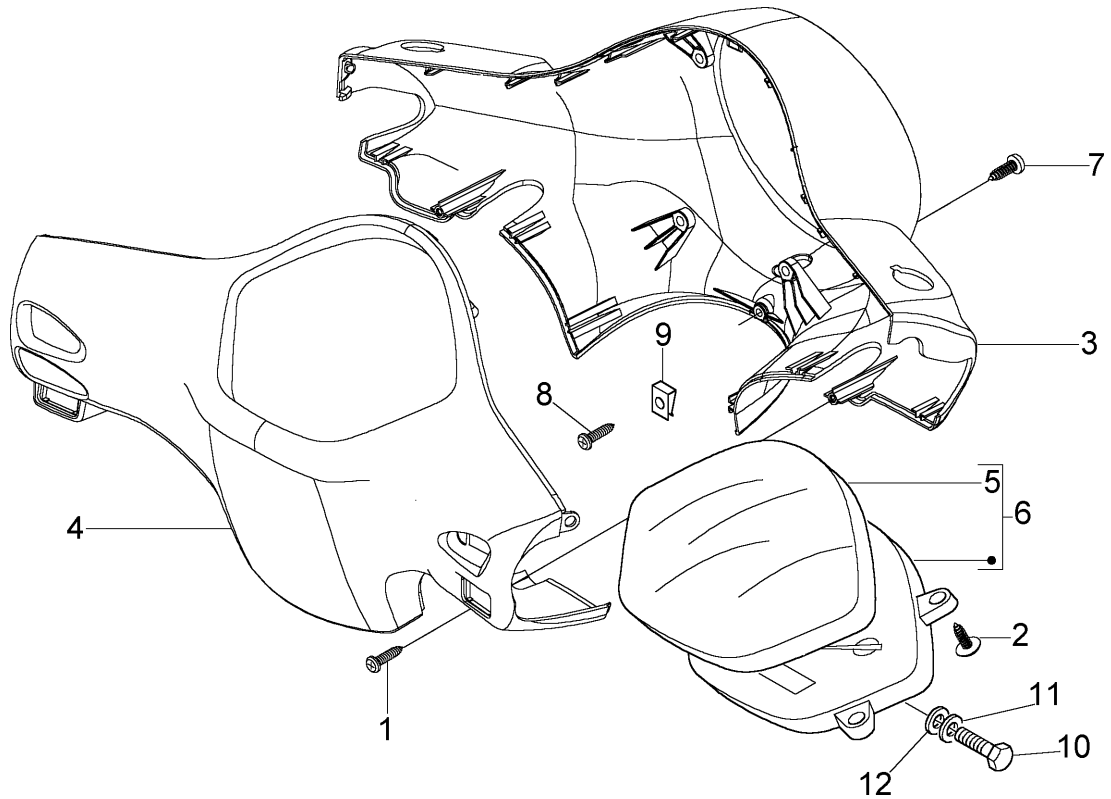

Pos. Pos. Loc. Pos. Pos.	Numero Número Number Nummer Número	Q.tà Q.té Q.ty M.ge Cant.	Nota Note Nota Anm. Nota	Denominazione	Désignation	Description	Beschreibung	Descripción
4	62219040F2	1	738/A	Coprimanubrio posteriore	Cache direction AR.	Rear handlebars cover	Lenkerdeckel hinterer	Cubre manillar tras.
4	62219040R7	1	894	Coprimanubrio posteriore	Cache direction AR.	Rear handlebars cover	Lenkerdeckel hinterer	Cubre manillar tras.
5	497398	1		Trasparente	Transparent	Glas	Kappe	Transparente
6	639292	1		Gruppo strumenti	Groupe instr.	Meter assy, combination	Cockpitinstrumente	Tablero de instrumentos
7	008457	1		Vite	Vis	Screw	Schraube	Tornillo
8	270793	3		Vite	Vis	Screw	Schraube	Tornillo
9	CM017409	1		Piastrina	Plaquette	Plate	Plättchen	Placa
10	031056	1		Vite	Vis	Screw	Schraube	Tornillo
11	016405	1		Rondella	Rondelle	Washer	U.Scheibe	Arandela
12	006078	1		Rondella	Rondelle	Washer	U.Scheibe	Arandela



**COMPONENTI DEL MANUBRIO
PIECES COMPOSANT LE GUIDON
HANDLEBARS COMPONENT PARTS
LENKER BAUTEILE
PIEZAS QUE COMPONEN EL MANILLAR**

T. 34

ZAPC 386B..5

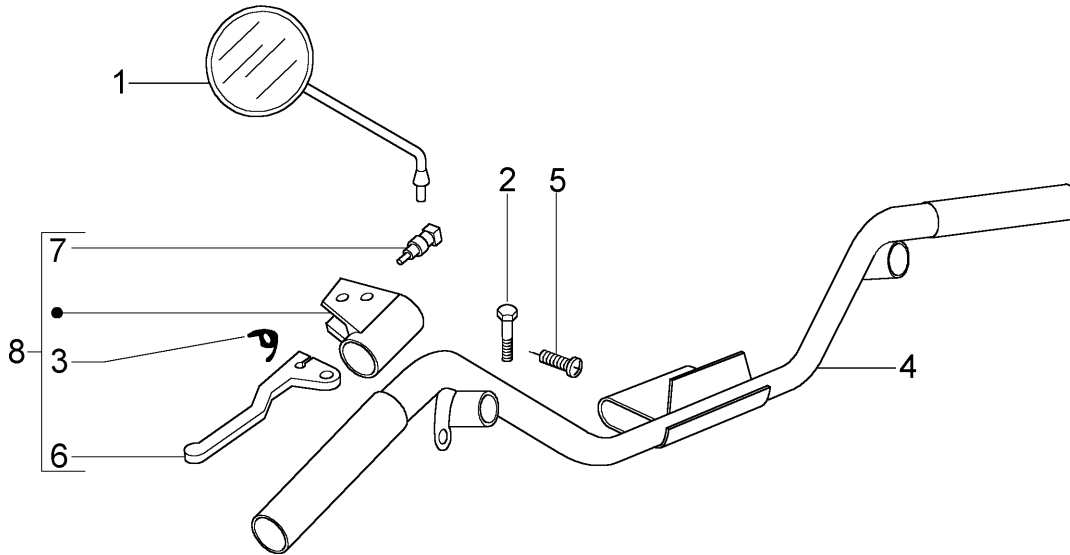

Pos. Pos. Loc. Pos. Pos.	Numero Numéro Number Nummer Número	Q.tà Q.té Q.ty M.ge Cant.	Nota Note Nota Anm. Nota	Denominazione	Désignation	Description	Beschreibung	Descripción
1	57328R	1		Coppia specchi retrovisori	Couple retroviseur	Mirror couple	Rückspiegelpaar	Ejepeo retrovisor
2	265249	1		Vite	Vis	Screw	Schraube	Tornillo
3	267948	1		Molla sx.	Ressort g.	Spring, L.H.	Feder	Muelle izq.
4	6221935	1		Manubrio	Guidon	Handlebars	Lenker	Manillar
5	123394	1		Vite	Vis	Screw	Schraube	Tornillo
6	564683	1		Leva	Levier	Lever	Hebel	Palanca
7	583575	1		Interruttore stop	Interrupteur stop	Stop switch	Stopschalter	Interruptor stop
8	CM063804	1		Manicotto	Manchon	Sleeve	Muffe	Manguito



COMPONENTI DEL MANUBRIO
PIECES COMPOSANT LE GUIDON
HANDLEBARS COMPONENT PARTS
LENKER BAUTEILE
PIEZAS QUE COMPONEN EL MANILLAR

T. 35

ZAPC 386B..5

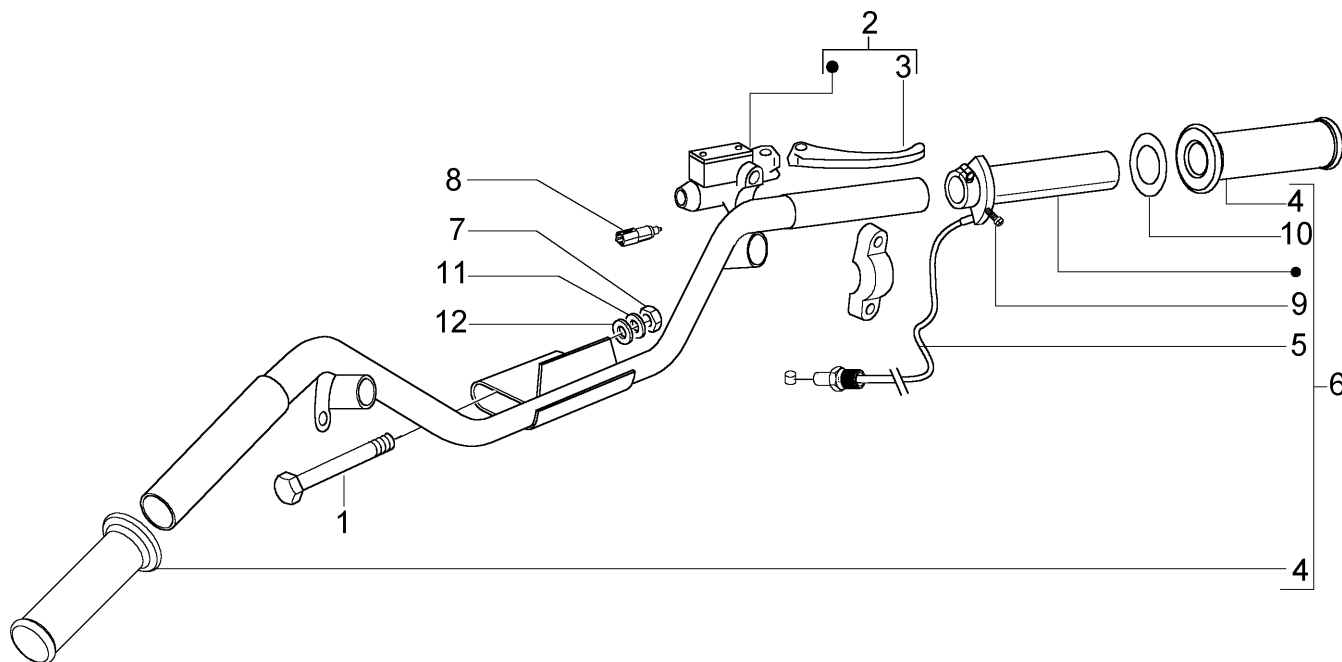

Pos. Pos. Loc. Pos. Pos.	Numero Número Number Nummer Número	Q.tà Q.té Q.ty M.ge Cant.	Nota Note Nota Anm. Nota	Denominazione	Désignation	Description	Beschreibung	Descripción
1	223605	1		Bullone	Boulon	Bolt	Bolzen	Tornillo
2	CM074901	1		Pompa freno	Maître cylindre	Master cil.	Hauptbremszylinder	Bomba freno
3	646833	1	HT	Leva freno	Levier du frein	Brake lever	Bremshebel	Palanca de freno
4	274489	1	SX	Manopola	Poignée	Grip	Handgriff	Puño
4	274491	1	DX	Manopola	Poignée	Grip	Handgriff	Puño
5	601716	1		Trasmissione comando gas	Transmission gaz	Throttle transmission	Gaszug gas	Trasmissione gas
6	CM060968	1		Manicotto	Manchon	Sleeve	Muffe	Manguito
7	015330	1		Dado	Ecrou	Nut	Mutter	Tuerca
8	583575	1		Interruttore stop	Interrupteur stop	Stop switch	Stopschalter	Interruptor stop
9	123394	1		Vite buss.	Vis	Screw	Schraube	Tornillo
10	562923	1		Rondella	Rondelle	Washer	U.Scheibe	Arandela
11	012543	1		Rondella	Rondelle	Washer	U.Scheibe	Arandela
12	178790	1		Rondella	Rondelle	Washer	U.Scheibe	Arandela



TRASMISSIONI - TUBAZIONE FRENO
TRANSMISSIONS - TUYAU FREIN
TRANSMISSIONS - BRAKE PIPING
BOWDENZÜGE - BREMSSCHLAUCH
TRANSMISIONES - TUBO FRENO

T. 36

ZAPC 386B..5

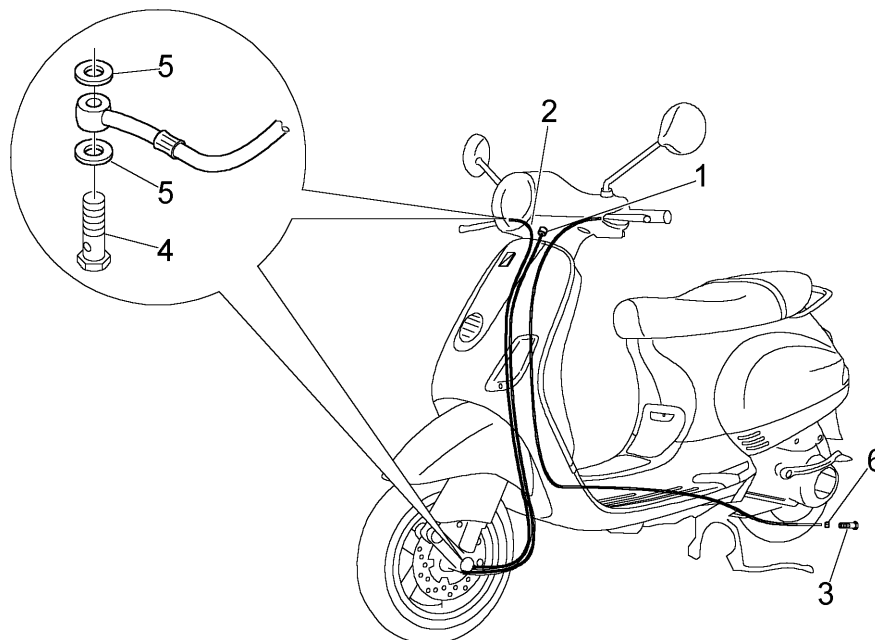

Pos. Pos. Loc. Pos. Pos.	Numero Numéro Number Nummer Número	Q.tà Q.té Q.ty M.ge Cant.	Nota Note Nota Anm. Nota	Denominazione	Désignation	Description	Beschreibung	Descripción
1	601618	1		Trasmissione contakm	Transmission compteur km.	Speedom. transmiss.	Tachowelle	Transmisión cuenta km.
2	646893	1		Tubazione	Tuyau	Piping	Schlauch	Tubo
3	270310	1		Registro fr.	Vis régl. frein	Brake adj. screw	Bremseinstellschr.	Tornillo reg. freno
4	265451	2		Vite	Vis	Screw	Schraube	Tornillo
5	127927	4		Guarnizione	Joint	Packing	Dichtung	Junta
6	179640	1		Perno	Pivot	Pin	Zapfen	Perno



**FANALERIA ANTERIORE
FEUX AVANT
FRONT LIGHTS
VORDERBELEUCHTUNG
FAROS DELANTEROS**

T. 37

ZAPC 386B..5

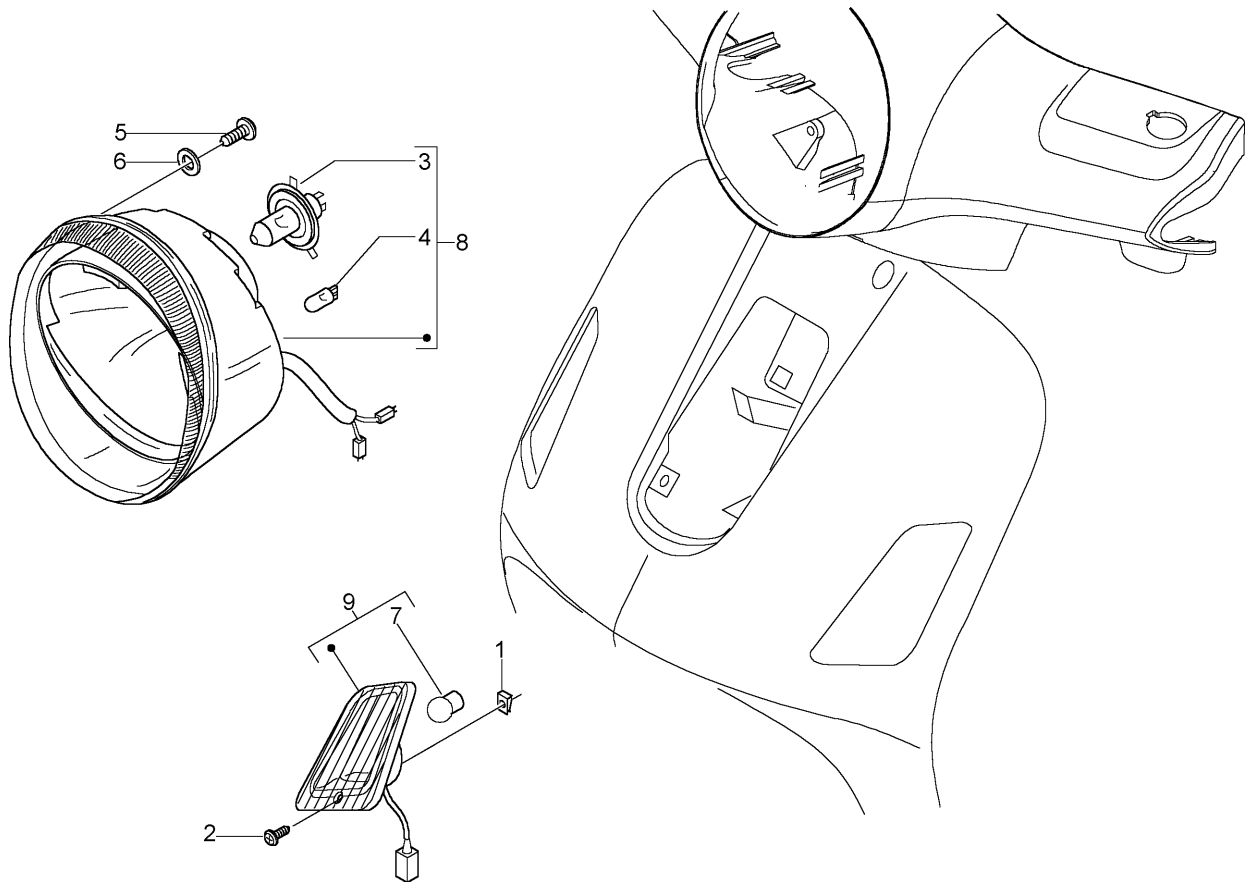

Pos. Pos. Loc. Pos. Pos.	Numero Número Number Nummer Número	Q.tà Q.té Q.ty M.ge Cant.	Nota Note Nota Anm. Nota	Denominazione	Désignation	Description	Beschreibung	Descripción
1	CM017406	2		Piastrina	Plaquette	Plate	Plättchen	Placa
2	008457	2		Vite	Vis	Screw	Schraube	Tornillo
3	231215	1	12V- 35/35W	Lampada	Ampoule	Bulb	Lampe	Bombilla
4	292022	1	12V-5W	Lampada	Ampoule	Bulb	Lampe	Bombilla
5	015715	4		Vite	Vis	Screw	Schraube	Tornillo
6	006965	4		Rondella	Ecrou	Nut	Mutter	Tuerca
7	181746	2	12V-10W	Lampada	Ampoule	Bulb	Lampe	Bombilla
8	639280	1		Proiettore	Projecteur	Headlamp	Scheinwerfer	Faro
9	639297	1	DX	Indicatore ant.	Clignotant AV.	Fr. turn sig.lamp	Blinkleuchte vorne	Intermitente
9	639296	1	SX	Indicatore ant.	Clignotant AV.	Fr. turn sig.lamp	Blinkleuchte vorne	Intermitente



**PROTEZIONE POSTERIORE
PROTECTION ARRIERE
REAR GUARD
HINTERE ABDECKUNG
PROTECCIÓN TRASERA**

T. 38

ZAPC 386B..5

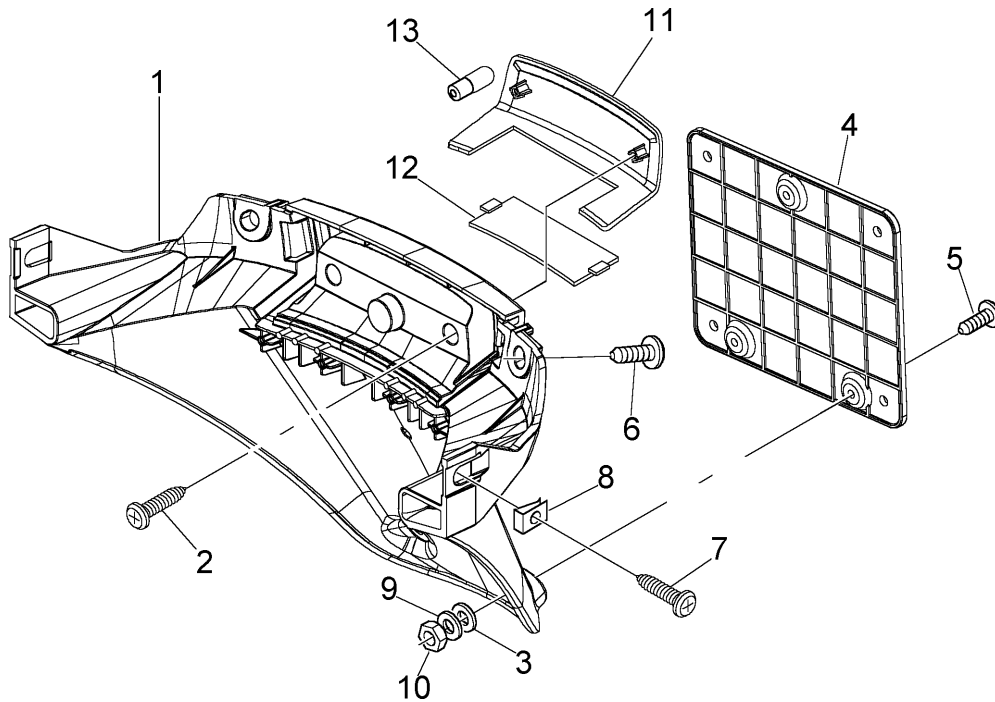

Pos. Pos. Loc. Pos. Pos.	Numero Número	Q.tà Q.té Q.ty M.ge Cant.	Nota Note Nota Anm. Nota	Denominazione	Désignation	Description	Beschreibung	Descripción
1	62212340ND	1	79/A	Protezione post.	Prot. AR.	Rear protection	Schutz hinten	Protección tras.
1	62212340BM	1	525	Protezione post.	Prot. AR.	Rear protection	Schutz hinten	Protección tras.
1	62212340F2	1	738/A	Protezione post.	Prot. AR.	Rear protection	Schutz hinten	Protección tras.
1	62212340R7	1	894	Protezione post.	Prot. AR.	Rear protection	Schutz hinten	Protección tras.
1	62212340F3	1	146	Protezione post.	Prot. AR.	Rear protection	Schutz hinten	Protección tras.
2	008432	2		Vite	Vis	Screw	Schraube	Tornillo
3	016404	3		Rondella	Ecrou	Nut	Mutter	Tuerca
4	584884	1		Portatarga	Porte-plaque	Plate holder	Kennzeichenträger	Porta matr.
5	018591	3		Vite	Vis	Screw	Schraube	Tornillo
6	259830	2		Vite	Vis	Screw	Schraube	Tornillo
7	575249	2		Vite	Vis	Screw	Schraube	Tornillo
8	254485	4		Piastrina	Plaquette	Plate	Plättchen	Placa
9	013763	3		Rondella	Ecrou	Nut	Mutter	Tuerca
10	020104	3		Dado	Rondelle	Washer	U.Scheibe	Arandela
11	63881040ND	1	79/A	Tappo	Bouchon	Plug	Verschluß	Tapón
11	63881040BM	1	525	Tappo	Bouchon	Plug	Verschluß	Tapón
11	63881040F2	1	738/A	Tappo	Bouchon	Plug	Verschluß	Tapón
11	63881040R7	1	894	Tappo	Bouchon	Plug	Verschluß	Tapón
11	63881040F3	1	146	Tappo	Bouchon	Plug	Verschluß	Tapón
12	639335	1		Trasparente	Transparent	Glas	Kappe	Transparente
13	292022	1		12V-5W Lampada	Ampoule	Bulb	Lampe	Bombilla



**FANALINO POSTERIORE
FEU AR.
REAR TAIL LAMP
HINTERRAD SCHLÜBLEUCHE
PILOTO**

T. 39

ZAPC 386B..5

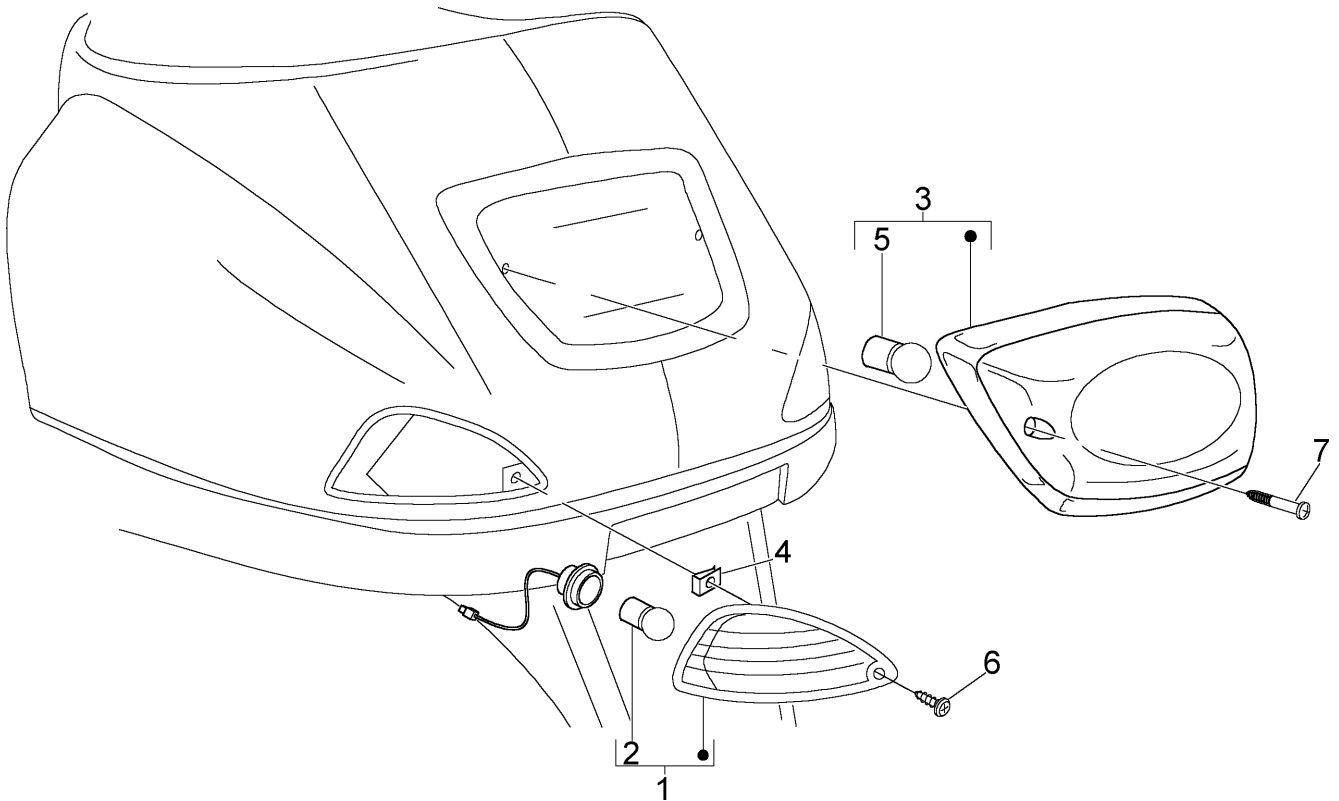

Pos. Pos. Loc. Pos. Pos.	Numero Número Number Nummer Número	Q.tà Q.té Q.ty M.ge Cant.	Nota Note Nota Anm. Nota	Denominazione	Désignation	Description	Beschreibung	Descripción
1	639285	1	SX	Indicatore dir.	Clignotant	Turn signal lamp	Blinkleuchte	Intermitente
1	639286	1	DX	Indicatore dir.	Clignotant	Turn signal lamp	Blinkleuchte	Intermitente
2	584332	2	12V-10W	Lampada	Ampoule	Bulb	Lampe	Bombilla
3	639281	1		Fanale post.	Feu AR.	Tail lamp	Rückleuchte	Piloto
4	CM017405	2		Piastrina	Plaquette	Plate	Plättchen	Placa
5	129953	1	12V- 5/21W	Lampada	Ampoule	Bulb	Lampe	Bombilla
6	008372	2		Vite	Vis	Screw	Schraube	Tornillo
7	015996	2		Vite	Vis	Screw	Schraube	Tornillo



**DISPOSITIVI ELETTRICI
DISPOSITIFS ELECTRIQUES
ELECTRICAL DEVICE
ELEKTRISCHE AUSRÜSTUNG
DISPOSITIVOS ELECTRICOS**

T. 40

ZAPC 386B..5

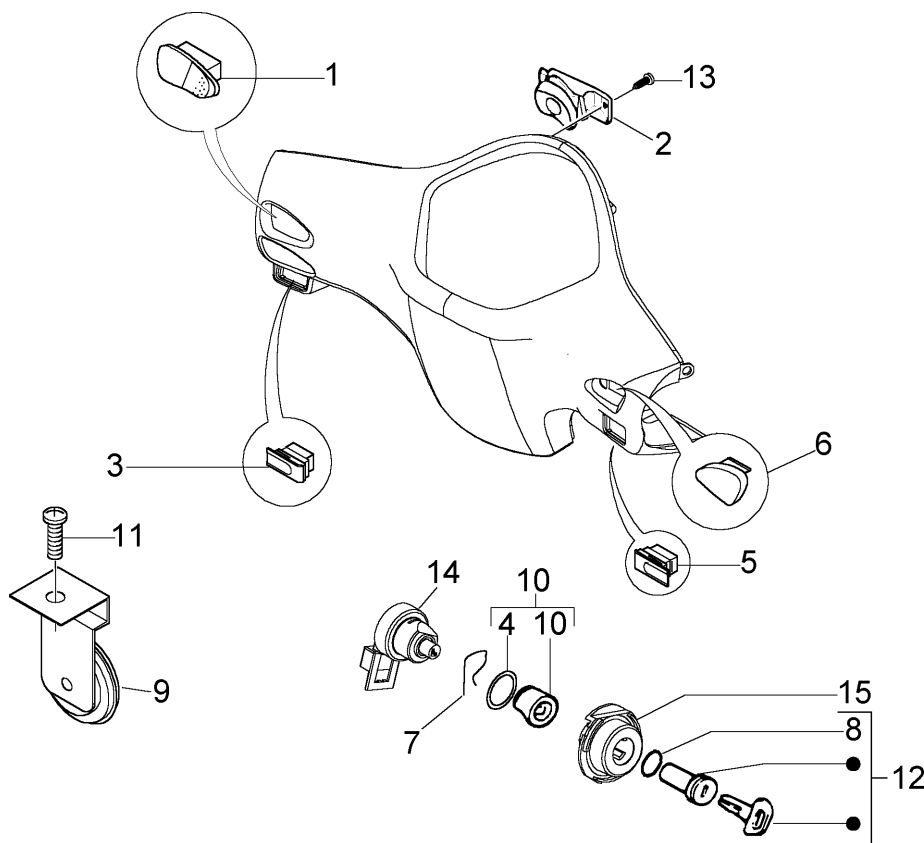

Pos. Pos. Loc. Pos. Pos.	Numero Numéro Number Nummer Número	Q.tà Q.té Q.ty M.ge Cant.	Nota Note Nota Anm. Nota	Denominazione	Désignation	Description	Beschreibung	Descripción
1	294877	1		Deviatore luci	Inverseur code/phare	Headlight selector	Umschalter Fernlicht/Fahrlicht	Desviador luz
2	294723	1		Commutatore	Commutateur	Switch	Schalter	Conmutador
3	638976	1		Pulsante claxon	Poussoir pour avertisseur	Horn button	Hupendruckknopf	Botón claxon
4	298838	1		Molletta arresto	Ressort d'arrêt	Spring	Drahtspannfeder	Muelle parada
5	638975	1		Pulsante avv.to	Pouss. démarr.	Starting button	Starterknopf	Botón arranque
6	584599	1		Deviatore arresto motore	Commutateur	Engine stop switch	Umschalter	Desviador parada motor
7	253937	1		Molletta arresto	Ressort d'arrêt	Spring	Drahtspannfeder	Muelle parada
8	298731	1		Anello or	Bague d'étanchéité	Ring	O-Ring	Anillo OR
9	CM071802	1		Claxon	Avertisseur sonore	Horn	Hupe	Claxon
10	298903	1		Blocchetto	Bloc	Block	Schlossriegel	Bloque
11	434541	1		Vite	Vis	Screw	Schraube	Tornillo
12	573905	1		Gr. Cilindretti	GR. Cylindres	Cylinder set	Bausatz schloßzylinder	Grupo cilindros
13	258403	2		Vite	Vis	Screw	Schraube	Tornillo
14	580621	1		Commutatore a chiave	Commutateur à clef	Key operated switch	Zündschalter	Conmutador de llave
15	298581	1		Corpo serratura	Corps serrure	Lock body	Schloßaufnahme	Cuerpo cerradura



**DISPOSITIVI ELETTRICI
DISPOSITIFS ELECTRIQUES
ELECTRICAL DEVICE
ELEKTRISCHE AUSRÜSTUNG
DISPOSITIVOS ELECTRICOS**

T. 41

ZAPC 386B..5

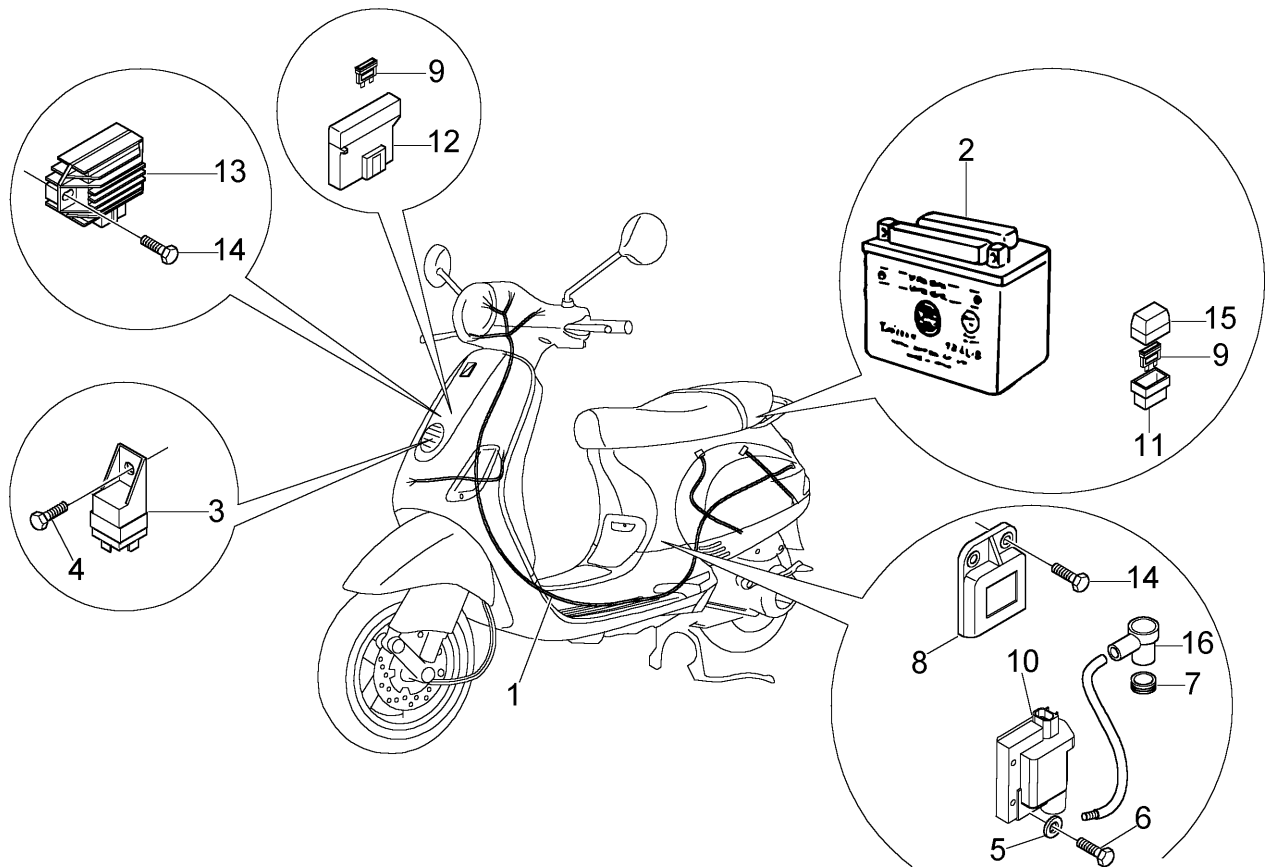

Pos. Pos. Loc. Pos. Pos.	Numero Numéro Number Nummer Número	Q.tà Q.té Q.ty M.ge Cant.	Nota Note Nota Anm. Nota	Denominazione	Désignation	Description	Beschreibung	Descripción
1	639302	1		Gruppo cavetti	Faisceau de câbles	Cable harness	Kabelbaum	Grupo de cables
2	584810	1	12V-9Ah	Batteria	Batterie	Battery	Batterie	Bateria
3	584521	1	12V-80A	Teleruttore	Relais	Rem. control switch	Fernschalter	Telerruptor
4	833722	1		Vite	Vis	Screw	Schraube	Tornillo
5	012528	1		Rondella	Rondelle	Washer	U.Scheibe	Arandela
6	015856	1		Vite	Vis	Screw	Schraube	Tornillo
7	828339	1		Collare	Collier	Clamp	Schelle	Abrazadera
8	639069	1		Dispositivo	Dispositif	Device	Vorrichtung	Dispositivo
9	290860	1	15A	Fusibile	Fusible	Fuse	Sicherung	Fusible
9	293256	2	5A	Fusibile	Fusible	Fuse	Sicherung	Fusible
9	292507	1	10A	Fusibile	Fusible	Fuse	Sicherung	Fusible
10	829337	1		Bobina A.T.	Bobine	Coil	Spule	Bobina
11	580653	1		Portafusibile	Porte fus.	Fuse holder	Sicherungshalter	Porta fusible
12	292893	1		Portafusibile	Porte fus.	Fuse holder	Sicherungshalter	Porta fusible
13	58025R	1		Regolatore	Régulateur	Regulator	Regler	Regulador
14	434541	3		Vite	Vis	Screw	Schraube	Tornillo
15	290404	1		Coperchio	Couvercle	Cover	Deckel	Tapa
16	969348	1		Cappuccio	Cache	Cap	Kappe	Capuchón



RUOTA ANTERIORE
ROUE AV.
FRONT WHEEL
VORDERRAD
RUEDA DELANTERA

T. 42

ZAPC 386B..5

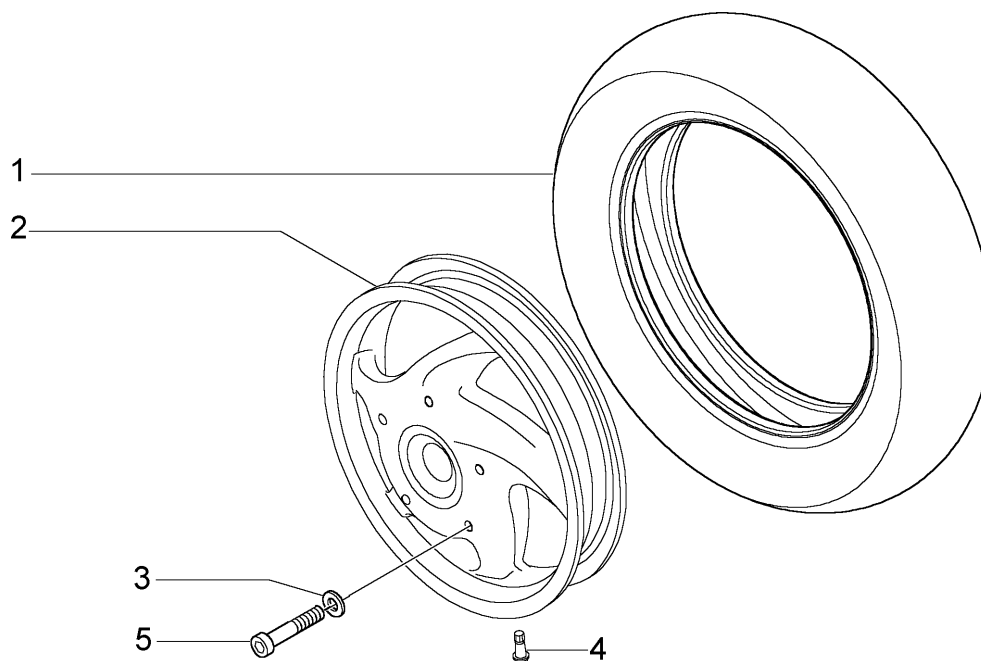

Pos. Pos. Loc. Pos. Pos.	Numero Numéro Number Nummer Número	Q.tà Q.té Q.ty M.ge Cant.	Nota Note Nota Anm. Nota	Denominazione	Désignation	Description	Beschreibung	Descripción
1	599986	1		Pneumatico	Pneu	Tyre	Reifen	Neumático
2	599990	1		Ruota anteriore	Roue AV.	Fr.wheel	Vorderrad	Rueda delantera
3	709047	5		Rondella	Rondelle	Washer	U.Scheibe	Arandela
4	270991	1		Valvola	Volet de gaz	Valve	Ventil	Válvula gas
5	015792	5		Vite	Vis	Screw	Schraube	Tornillo



**RUOTA POSTERIORE
ROUE AR.
REAR WHEEL
HINTERRAD
RUEDA TRASERA**

T. 43

ZAPC 386B..5

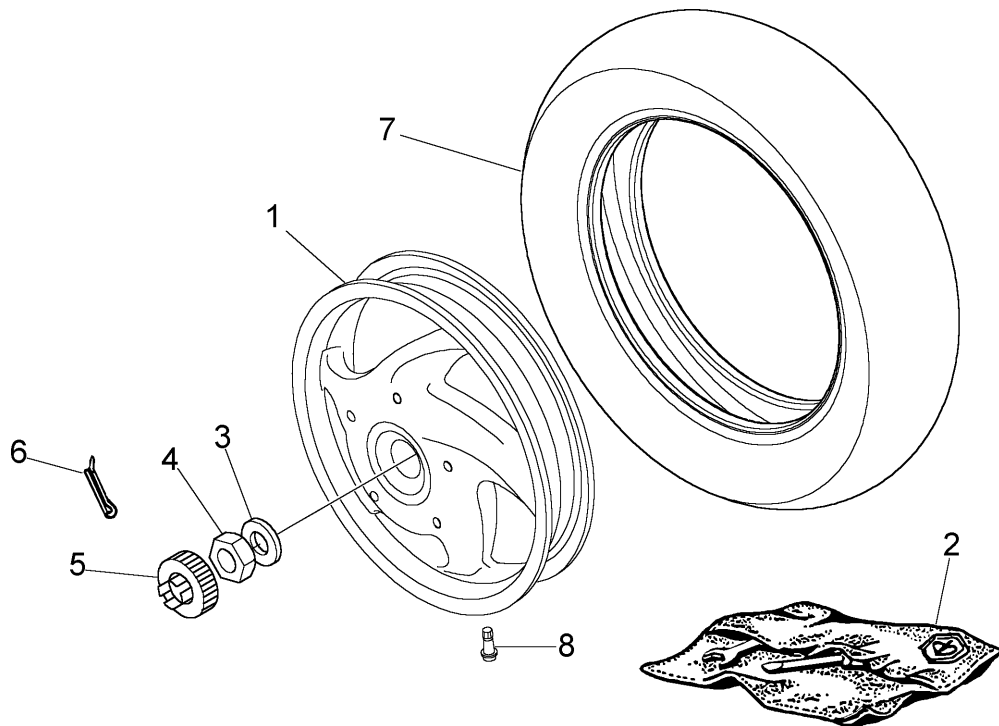

Pos. Pos. Loc. Pos. Pos.	Numero Número	Q.tà Q.té Q.ty M.ge Cant.	Nota Note Nota Anm. Nota	Denominazione	Désignation	Description	Beschreibung	Descrpción
1	600067	1		Ruota posteriore	Roue AR.	Rear wheel	Hinterrad	Rueda trasera
2	635101	1		Borsa attrezzi	Trousse à outils	Tool roll	Werkzeugtasche	Bolsa herramientas
3	273099	1		Rondella piana	Rondelle plate	Plain washer	U.Scheibe	Arandela plana
4	563728	1		Dado	Ecrou	Nut	Mutter	Tuerca
5	194423	1		Cappello	Cache	Cap	Kappe	Capuchón
6	012789	1		Coppiglia	Goupille	Split pin	Splint	Grupilla
7	560661	1		Pneumatico	Pneu	Tyre	Reifen	Neumático
8	270991	1		Valvola	Volet de gaz	Valve	Ventil	Válvula gas



**TARGHETTE
MONOGRAMMES
NAME PLATES
PLAKETTE
LETRERO**

T. 44

ZAPC 386B..5

! WARNING !

Batteries contain sulphuric acid which can cause severe injuries. Avoid contact with skin, eyes or clothing. Antidote: EXTERNAL - Flush with water INTERNAL - Drink large quantities of water or milk. Follow with milk or magnesium, beaten egg or vegetable oil. Call physician immediately. Eyes: flush with water for 15 minutes and get prompt medical attention. KEEP OUT OF REACH OF CHILDREN.

Batteries produce explosive gases. Keep sparks, flames, cigarettes away. Charge only in well ventilated space. Always wear protective goggles when working around batteries. Always connect the battery vent tube. Failure to heed this warning will cause corrosion of electrical system.

— 1

! WARNING !

Do not use any tire other than those recommended and approved by PIAGGIO & C. SpA. Maintain proper tire inflation. Do not use any tire with less than 1/12" (2 mm) tread remaining. Do not repair any tire, nor use a repaired tire. Do not ride your motorcycle overloaded or with an unbalanced load. Failure to follow these warnings can lead to an accident and serious injuries or death. See Owner's manual

	FRONT tire	REAR tire
Tires	120/90 - 10 85J	120/90 - 10 58J
Driver	1.3 bar (19.0 psi)	1.8 bar (26.1 psi)
Driver + passenger	1.3 bar (19.0 psi)	2.5 bar (36.3 psi)

— 5



3

! WARNING !

- Wear a helmet, eye protection and bright protective clothing.
- Don't ride after consuming alcohol or other drugs.
- Slow down on slippery surfaces, unfamiliar terrain or when visibility is reduced.
- Read owner's manual carefully.
- Failure to follow these warnings can lead to an accident and serious injuries or death.
- USE UNLEADED FUEL MINIMUM OCTANE RATING 91+M12 METHOD 80
- See owner's manual for the correct tuning in and maintenance of the vehicle.

— 2

! WARNING !

Never install accessories or replacement parts not approved by PIAGGIO & C. SpA on original equipment. This can degrade the handling and safety of your motorcycle, and can cause an upset with subsequent accidents and serious injury or even death. The stability and safety of any motorcycle is adversely affected by the addition of any load carrying accessory. See owner's manual.

4

! WARNING !

Kick start lever.
Improper use can cause severe injuries. See owner's manual

6

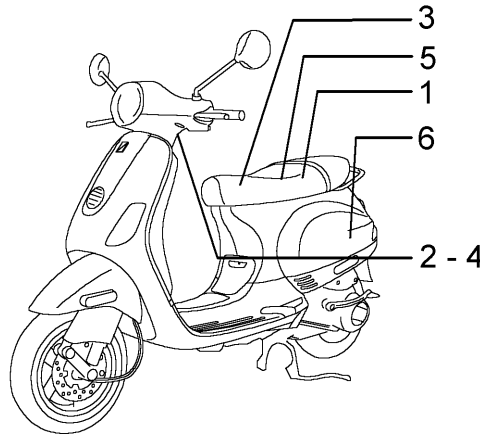

Pos. Pos. Loc. Pos. Pos.	Numero Número Number Number Número	Q.tà Q.té Q.ty M.ge Cant.	Nota Note Nota Anm. Nota	Denominazione	Désignation	Description	Beschreibung	Descripción
1	576702	1		Targhetta	Monogramme	Name plate	Plakette	Letrero
2	576704	1		Targhetta	Monogramme	Name plate	Plakette	Letrero
3	576953	2		Targhetta "NO PETS"	Monogramme "NO PETS"	"NO PETS" name plate	"NO PETS" plakette	Letrero "NO PETS"
4	576708	1		Targhetta	Monogramme	Name plate	Plakette	Letrero
5	623705	1		Targhetta	Monogramme	Name plate	Plakette	Letrero
6	576707	1		Targhetta "KICK START"	Monogramme "KICK START"	"KICK START" Name plate	"KICK START" Plakette	Letrero "KICK START"

PIAGGIO & C. S.p.A
AFTER SALES SERVICE
Pubblicazione dis. 633493
04/2005