

# 15. REAR BRAKE/REAR FORK/REAR WHEEL/REAR SHOCK ABSORBER

---

---

---

---

---

---

---

**REAR BRAKE/REAR FORK/REAR WHEEL/  
REAR SHOCK ABSORBER**

---

SCHEMATIC DRAWING-----	15-1
SERVICE INFORMATION-----	15-2
TROUBLESHOOTING -----	15-2
REAR BRAKE -----	15-3
REAR FORK -----	15-6
REAR WHEEL-----	15-7
REAR SHOCK ABSORBER -----	15-7

# 15. REAR BRAKE/REAR FORK/REAR WHEEL/REAR SHOCK ABSORBER

## SCHEMATIC DRAWING

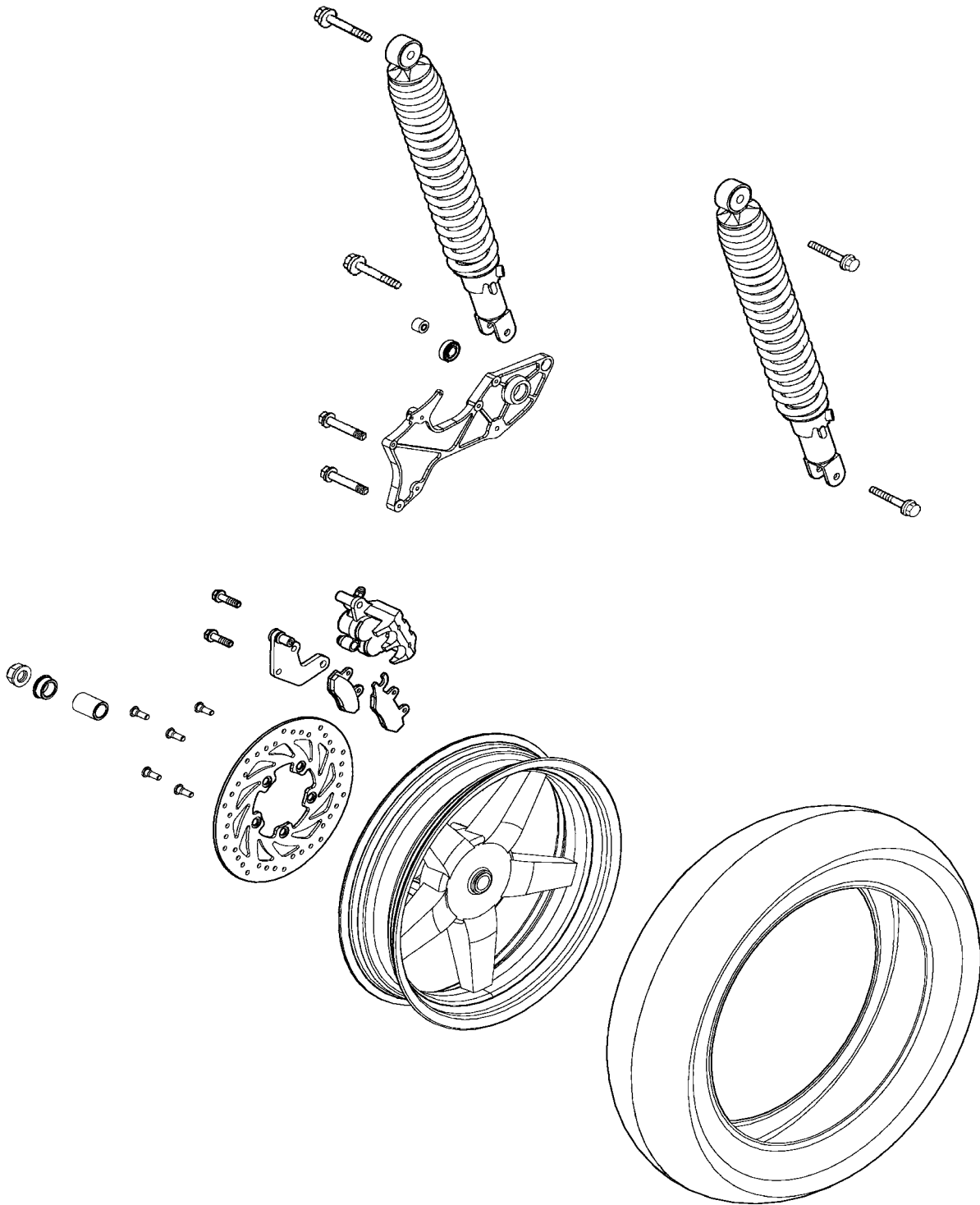

# 15. REAR BRAKE/REAR FORK/REAR WHEEL/REAR SHOCK ABSORBER

## SERVICE INFORMATION

### GENERAL INSTRUCTIONS

- When performing the services stated in this section, the engine and exhaust muffler must be cold to avoid scalding.
- During servicing, keep oil or grease off the brake pads and brake disk.

### SPECIFICATIONS

Item	Standard (mm)	Service Limit (mm)
Rear wheel rim runout	—	2.0
Rear brake disk thickness	4.0	3.0
Rear brake disk runout	—	0.30
Rear brake master cylinder I.D.	27.00	27.05
Rear brake master cylinder piston O.D.	26.95	26.90

### TORQUE VALUES

Exhaust muffler lock bolt	32~38N-m
Exhaust muffler pipe nut	18~22N-m
Rear axle nut	110~130N-m
Rear shock absorber lower mount bolt	35~45N-m
Rear shock absorber upper mount bolt	35~45N-m
Rear brake caliper holder bolt	29~35N-m

### TROUBLESHOOTING

#### Rear wheel wobbling

- Bent rim
- Faulty tire
- Axle not tightened properly

#### Soft rear shock absorber

- Weak shock absorber spring
- Damper oil leaks

#### Rear wheel noise

- Worn rear wheel axle bearings
- Worn rear fork bearings
- Deformed rear fork

#### Poor brake performance

- Air in brake system
- Deteriorated brake fluid
- Contaminated brake pad surface
- Worn brake pads
- Clogged brake fluid line
- Deformed brake disk
- Unevenly worn brake caliper

# 15. REAR BRAKE/REAR FORK/REAR WHEEL/REAR SHOCK ABSORBER

## REAR BRAKE

### REAR BRAKE CALIPER REMOVAL

First remove the exhaust muffler. (⇒2-10)  
Remove the rear brake fluid tube bolt and disconnect the brake fluid tube.  
Remove the two bolts attaching the rear brake caliper.  
Remove the rear brake caliper.

\* When removing the brake fluid tube, use shop towels to cover plastic parts and coated surfaces to avoid damage.

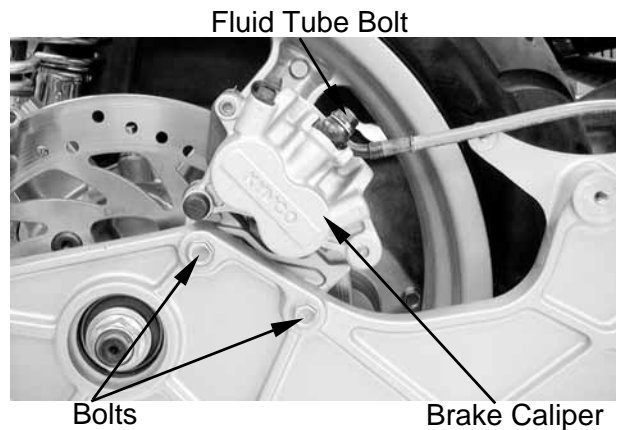

## INSPECTION

Inspect the brake pads and brake disk.

Measure the brake disk thickness.

**Service Limit:** 3.0mm replace if below



Visually check the brake pad thickness and it should not exceed the wear indicator mark.

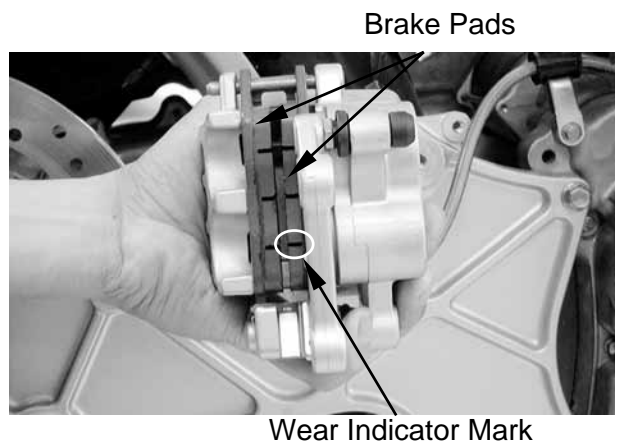

## DISASSEMBLY

Remove the two brake pads dowel pins and three bolts from the brake caliper.

Remove the brake pads.

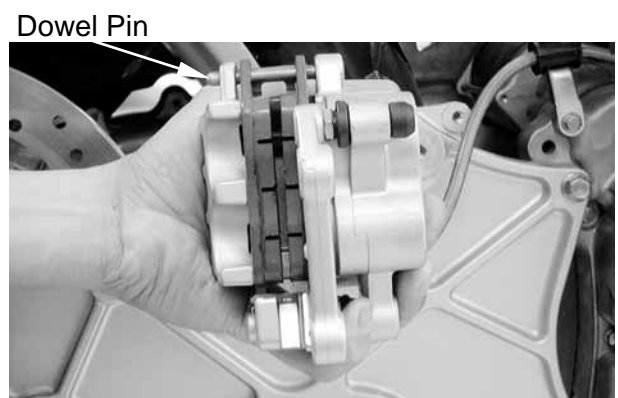

# 15. REAR BRAKE/REAR FORK/REAR WHEEL/REAR SHOCK ABSORBER

Remove the piston from the brake caliper. If necessary, use compressed air to squeeze out the piston through the brake fluid inlet opening and place a shop towel under the caliper to avoid contamination caused by the removed piston.

Check the piston cylinder for scratches or wear and replace if necessary.

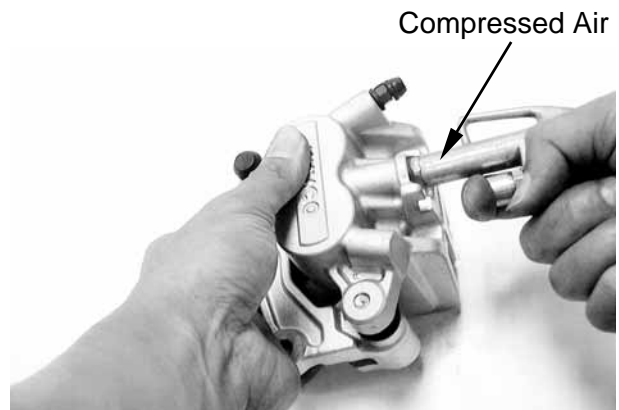

Push the piston oil seal outward to remove it. Clean the oil seal groove with brake fluid.

\* Be careful not to damage the piston surface.



Check the piston for scratches or wear. Measure the piston O.D. with a micrometer gauge.

**Service Limit:** 26.90mm



Check the caliper cylinder for scratches or wear and measure the cylinder bore.

**Service Limit:** 27.05mm



# 15. REAR BRAKE/REAR FORK/REAR WHEEL/REAR SHOCK ABSORBER

## ASSEMBLY

Clean all removed parts.

Apply silicon grease to the piston and oil seal.  
Lubricate the brake caliper cylinder inside wall with brake fluid.

Install the brake caliper piston with grooved side facing out.

\* Install the piston with its outer end protruding 3~5mm beyond the brake caliper.

Install the two spring plate into the groove of the caliper.



Spring Plate

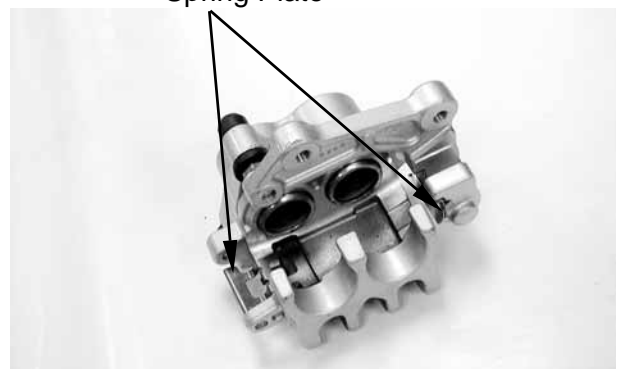

\* Make sure the spring plate next to the brake pad dowel pin orientation.

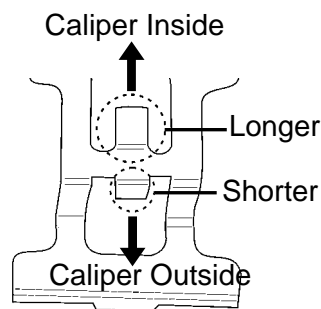

Install the two brake pads and brake pad dowel pin.

Dowel Pin

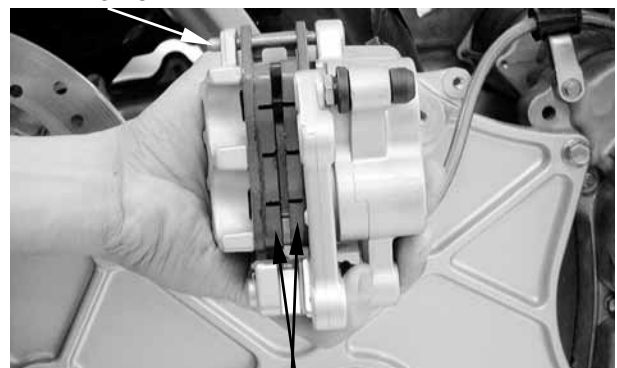

Brake Pads

# 15. REAR BRAKE/REAR FORK/REAR WHEEL/REAR SHOCK ABSORBER

## INSTALLATION

Install the brake caliper to the rear fork and tighten the two bolts.

**Torque:** 29~35N-m

Connect the brake fluid tube to the brake caliper and install fluid tube bolt, copper washers and tighten the fluid tube bolt. Fill the brake reservoir with the specified brake fluid and bleed air from the brake system. (⇒14-10)

\* When installing the brake fluid tube, be sure to install the two copper sealing washers.

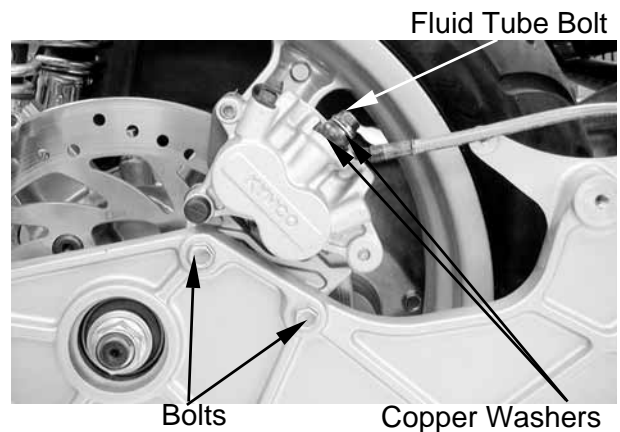

## REAR FORK

### REMOVAL

Remove the exhaust muffler. (⇒2-10)  
Remove the rear brake caliper. (⇒15-3)

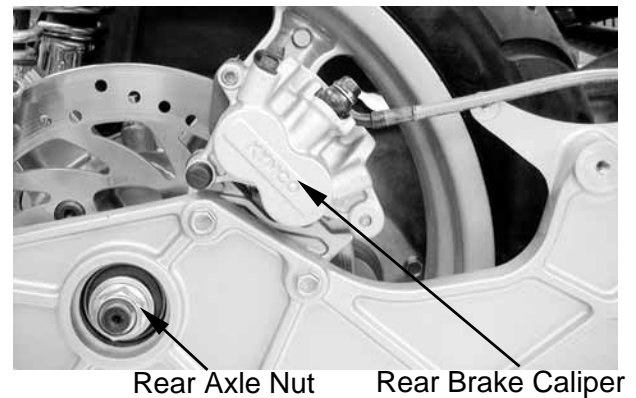

Remove the right rear shock absorber lower mount bolt.  
Remove the rear axle nut and remove the collar.  
Remove the rear fork.

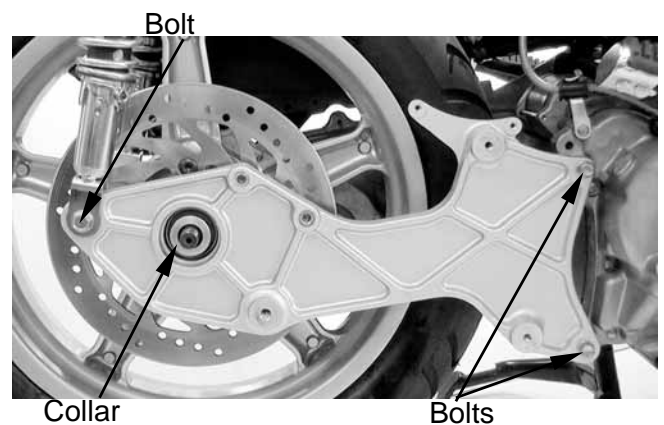

The installation sequence is the reverse of removal.

Turn the inner race of each bearing with your finger to see if they turn smoothly and quietly. Also check if the outer race fits tightly in the hub.

Replace the bearings if the races do not turn smoothly, quietly, or if they fit loosely in the hub.



# 15. REAR BRAKE/REAR FORK/REAR WHEEL/REAR SHOCK ABSORBER

## REAR WHEEL

### REMOVAL

- Remove the exhaust muffler. (⇒2-10)
- Remove the rear brake caliper. (⇒15-3)
- Remove the rear fork. (⇒15-6)
- Remove the rear axle collar.
- Remove the rear wheel.



Rear Brake Disk

Rear Axle Collar

### INSPECTION

Measure the rear wheel rim runout.

#### Service Limits:

- Radial:** 2.0mm replace if over
- Axial:** 2.0mm replace if over

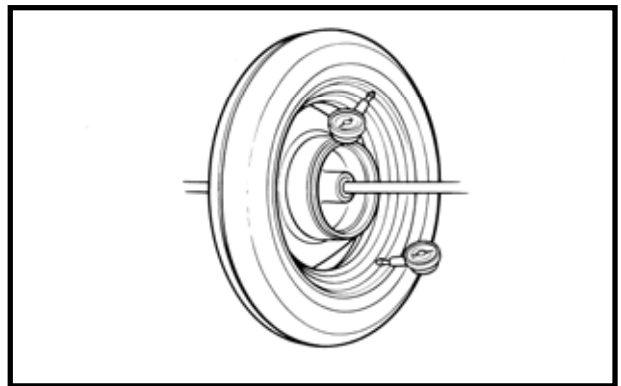

### INSTALLATION

The installation sequence is the reverse of removal.

#### Torque:

- Rear shock absorber lower mount bolt: 35~45N-m
- Rear axle nut: 110~130N-m



## REAR SHOCK ABSORBER

### REMOVAL

- Remove the met-in box and carrier. (⇒2-6)
- Remove the body cover, center cover and rear fender A together. (⇒2-6)
- Remove the right/left rear shock absorber upper and lower mount bolts.
- Remove the right and left rear shock absorbers.

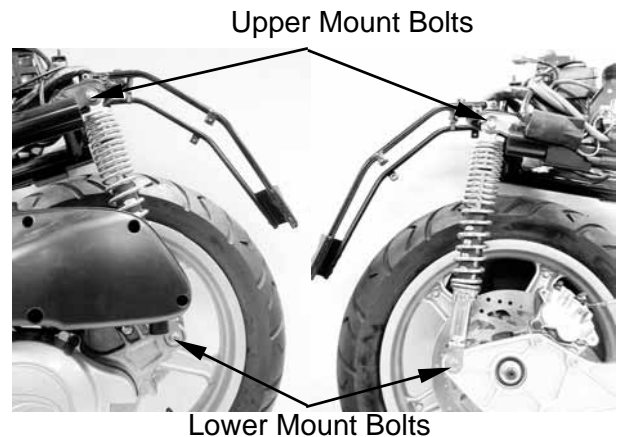



# 15. REAR BRAKE/REAR FORK/REAR WHEEL/REAR SHOCK ABSORBER

## INSTALLATION

Install the rear shock absorbers in the reverse order of removal.

### Torque:

Upper Mount Bolt: 35~45N-m

Lower Mount Bolt: 35~45N-m

## ADJUSTABLE REAR CUSHION

To suit scooter behaviour to load condition rear cushion could be adjusted in spring preload.

It is possible to adjust rear cushion in three positions:

A position "soft"

B position "medium"

C position "hard"

When you adjust rear cushion, the spring preload of rear cushions must be the same.

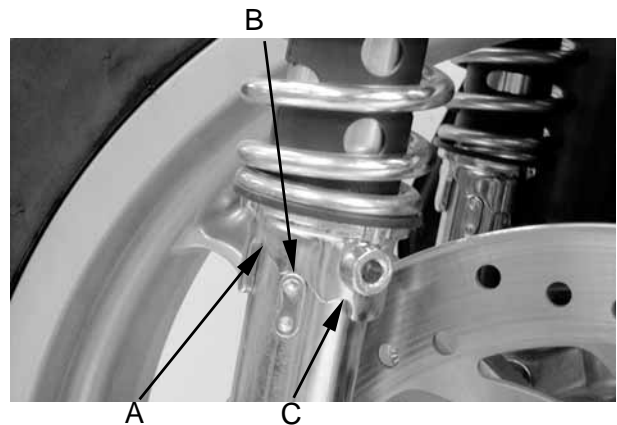

A cushion adjust wrench is provided with PEOPLE 250.

The rear right cushion can be adjusted directly with the wrench.

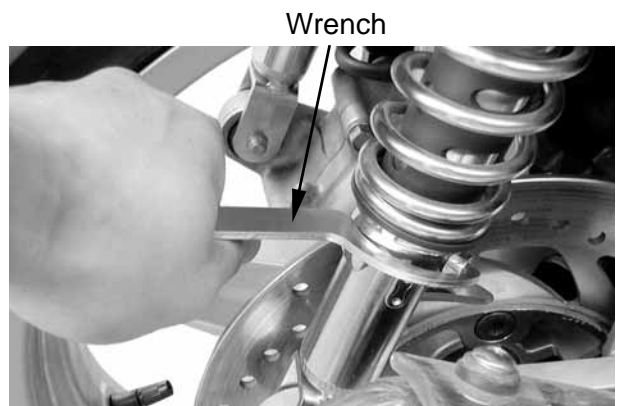

Remove the four bolts from air cleaner before rear left cushion to be adjusted.

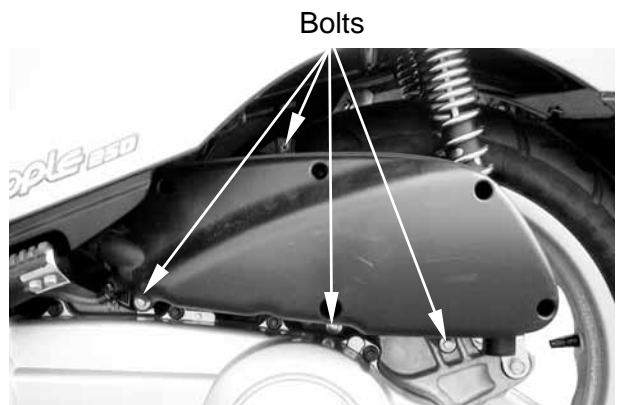

# 15. REAR BRAKE/REAR FORK/REAR WHEEL/REAR SHOCK ABSORBER

---

Disconnect the breather hose from air cleaner and keep air cleaner up to adjust rear left cushion with wrench.

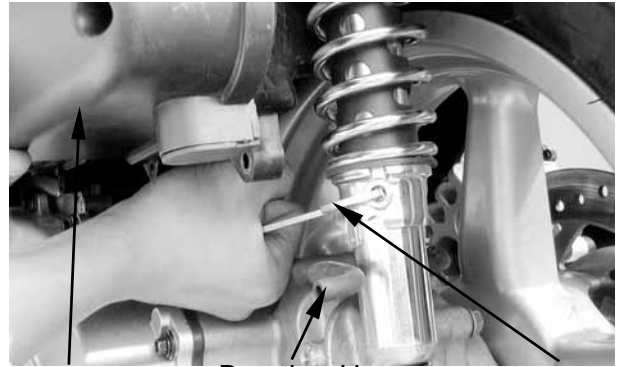

Air Cleaner

Breather Hose

Wrench