

7. CYLINDER/PISTON

CYLINDER/PISTON



SCHEMATIC DRAWING-----	7-1
SERVICE INFORMATION-----	7-2
TROUBLESHOOTING -----	7-2
CYLINDER REMOVAL -----	7-3
PISTON REMOVAL -----	7-3
PISTON INSTALLATION -----	7-7
CYLINDER INSTALLATION -----	7-7

7. CYLINDER/PISTON

SCHEMATIC DRAWING

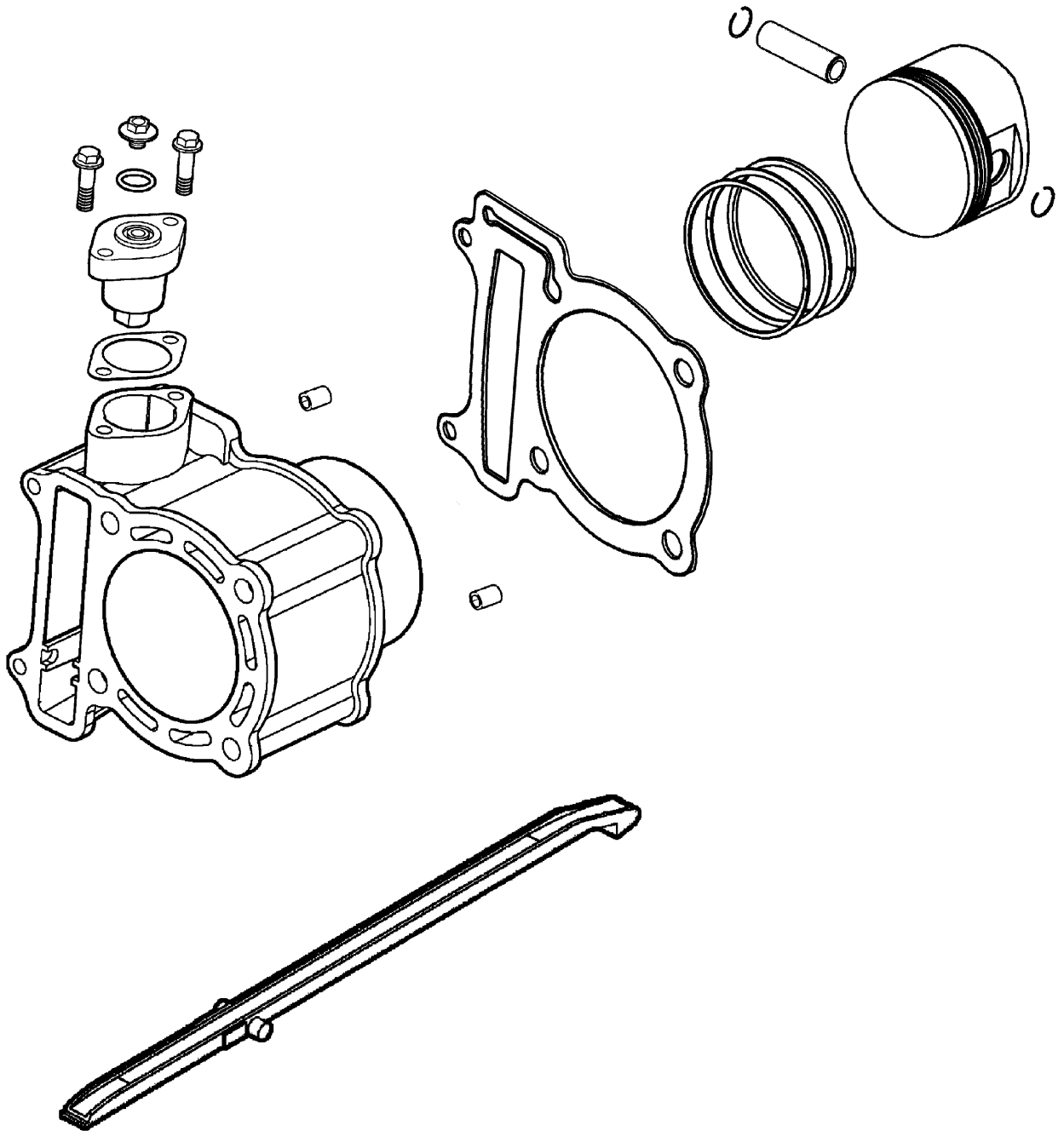

7. CYLINDER/PISTON

SERVICE INFORMATION

GENERAL INSTRUCTIONS

- The cylinder and piston can be serviced with the engine installed in the frame.
- When installing the cylinder, use a new cylinder gasket and make sure that the dowel pins are correctly installed.
- After disassembly, clean the removed parts and dry them with compressed air before inspection.

SPECIFICATIONS

Item		Standard (mm)		
		PEOPLE/PEOPLE S	PEOPLE/PEOPLE S	
Cylinder	I.D.	72.705~72.715	72.80	
	Warpage	0.01	0.05	
	Cylindricity	0.01	0.05	
	True roundness	0.01	0.05	
Piston, piston ring	Ring-to-groove clearance	top	0.02	0.09
		Second	0.015~0.050	0.09
	Ring end gap	top	0.1~0.25	0.50
		Second	0.15~0.30	0.50
		Oil side rail	0.25~0.7	1.0
	Piston O.D.	72.67~72.69	72.6	
	Piston O.D. measuring position	9mm from bottom of skirt	9mm from bottom of skirt	
	Piston-to-cylinder clearance	0.010~0.040	0.1	
Piston pin hole I.D.	17.002~17.008	17.04		
Piston pin O.D		16.994~17.000	16.96	
Piston-to-piston pin clearance		0.002~0.014	0.02	
Connecting rod small end I.D. bore		17.016~17.034	17.06	

TROUBLESHOOTING

- When hard starting or poor performance at low speed occurs, check the crankcase breather for white smoke. If white smoke is found, it means that the piston rings are worn, stuck or broken.

Compression too low or uneven compression

- Worn or damaged cylinder and piston rings
- Worn, stuck or broken piston rings

Compression too high

- Excessive carbon build-up in combustion chamber or on piston head

Excessive smoke from exhaust muffler

- Worn or damaged piston rings
- Worn or damaged cylinder and piston

Abnormal noisy piston

- Worn cylinder, piston and piston rings
- Worn piston pin hole and piston pin
- Incorrectly installed piston

7. CYLINDER/PISTON

CYLINDER REMOVAL

Remove the cylinder head. (⇒chapter 6)
 Remove the dowel pins and cylinder head gasket.
 Remove the water hose from the cylinder.

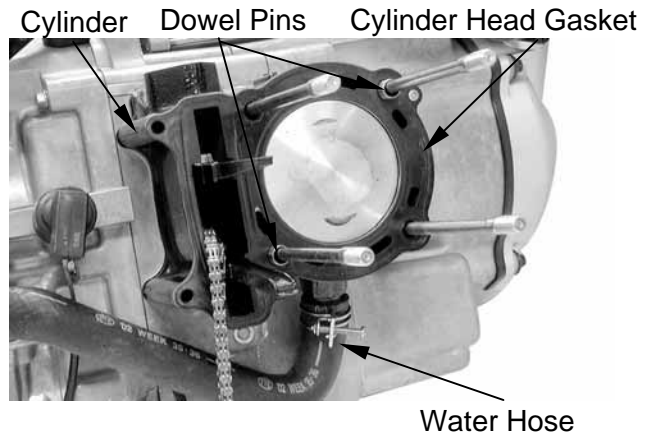

Remove the cam chain guide.
 Remove the cylinder.

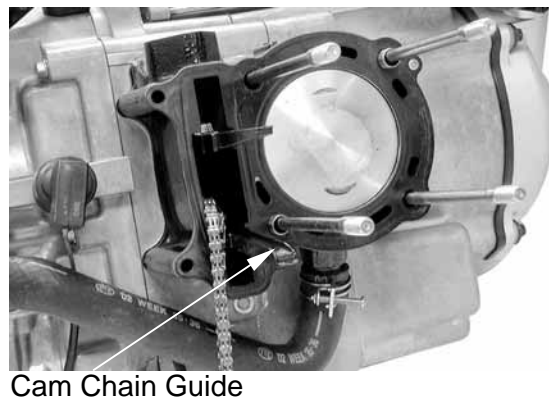

Remove the cylinder gasket and dowel pins.
 Clean any gasket material from the cylinder surface.

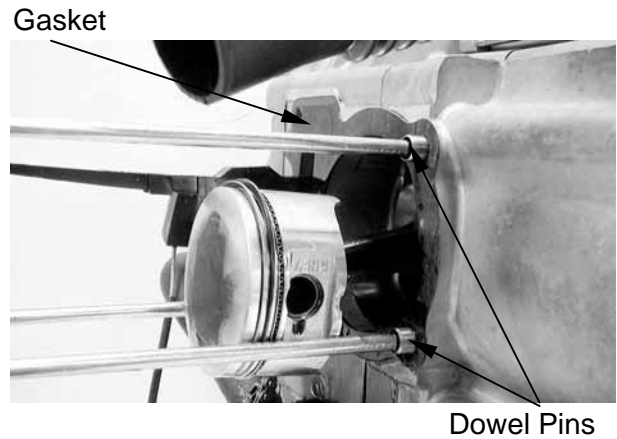

PISTON REMOVAL

Remove the piston pin clip.
 Press the piston pin out of the piston.

* Place a clean shop towel in the crankcase to keep the piston pin clip from falling into the crankcase.

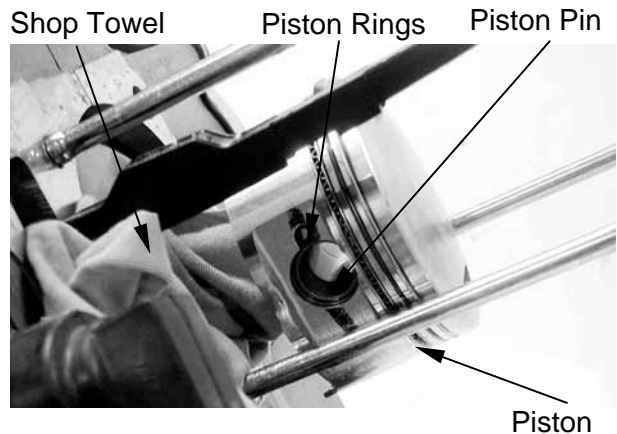

7. CYLINDER/PISTON

Inspect the piston, piston pin and piston rings.
Remove the piston rings.

- * • Take care not to damage or break the piston rings during removal.

Clean carbon deposits from the piston ring grooves.



Install the piston rings onto the piston and measure the piston ring-to-groove clearance.

Service Limits:

- Top:** 0.09mm replace if over
2nd: 0.09mm replace if over



Remove the piston rings and insert each piston ring into the cylinder bottom.

- * • Use the piston head to push each piston ring into the cylinder.

Measure the piston ring end gap.

Service Limit: 0.5mm replace if over



Measure the piston pin hole I.D.

Service Limit: 17.04mm replace if over



7. CYLINDER/PISTON

Measure the piston pin O.D.

Service Limit: 16.96mm replace if below



Measure the piston O.D.

- * • Take measurement at 9mm from the bottom and 90° to the piston pin hole.

Service Limit: 72.60mm replace if below

Measure the piston-to-piston pin clearance.

Service Limit: 0.02mm replace if over



CYLINDER INSPECTION

Inspect the cylinder bore for wear or damage. Measure the cylinder I.D. at three levels of top, middle and bottom at 90° to the piston pin (in both X and Y directions).

Service Limit: 72.80mm repair or replace if Over

Measure the cylinder-to-piston clearance.

Service Limit: 0.1mm repair or replace if Over



The true roundness is the difference between the values measured in X and Y directions. The cylindricity (difference between the values measured at the three levels) is subject to the maximum value calculated.

Service Limits:

True Roundness: 0.09mm repair or replace if over

Cylindricity: 0.09mm repair or replace if over

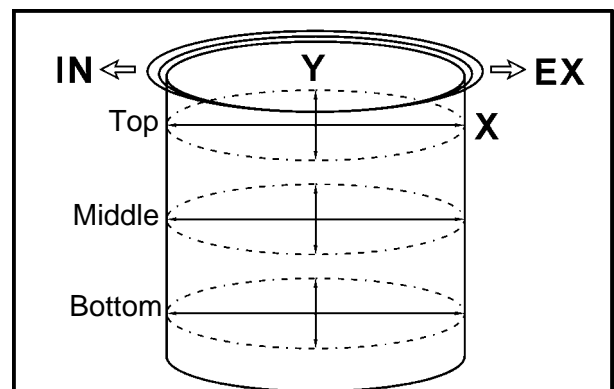

7. CYLINDER/PISTON

Inspect the top of the cylinder for warpage.
Service Limit: 0.05mm repair or replace if over

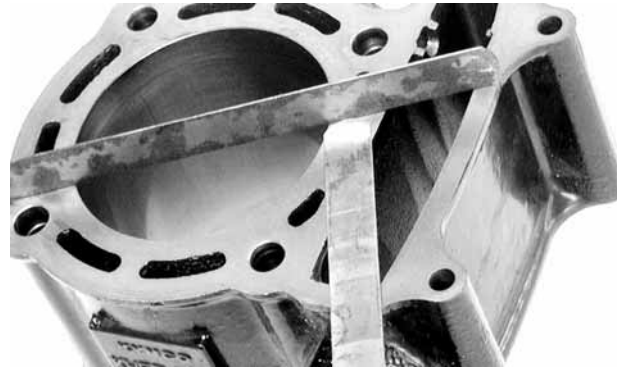

Measure the connecting rod small end I.D.
Service Limit: 17.06mm replace if over

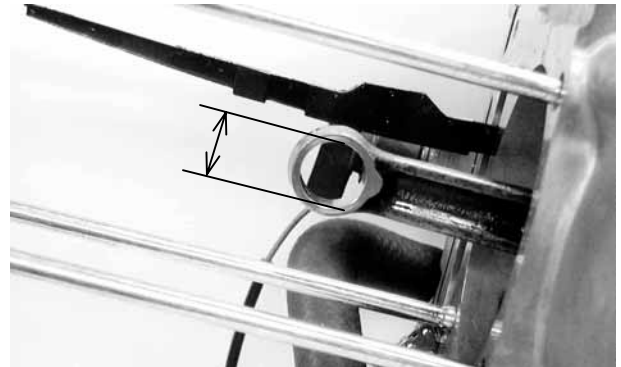

PISTON RING INSTALLATION

Install the piston rings onto the piston.
 Apply engine oil to each piston ring.

- *
- Be careful not to damage the piston and piston rings during assembly.
 - All rings should be installed with the markings facing up.
 - After installing the rings, they should rotate freely without sticking.
 - Stagger the ring end gaps as the figure shown.

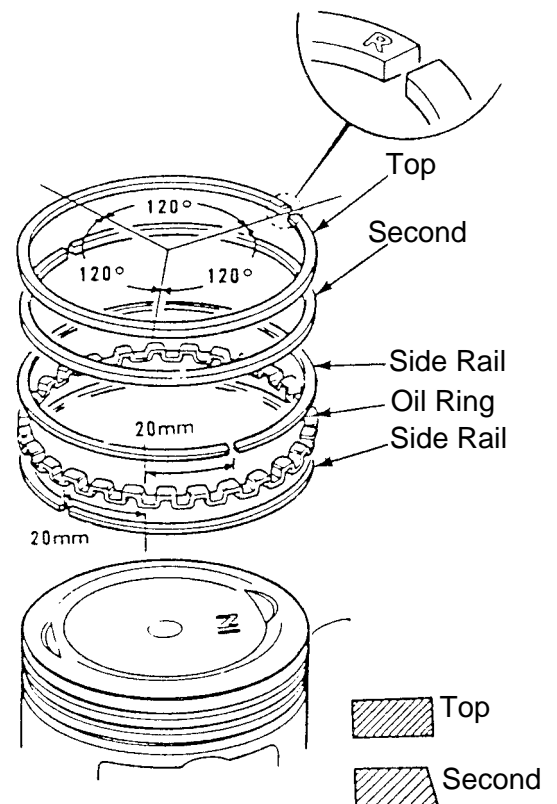

7. CYLINDER/PISTON

PISTON INSTALLATION

Remove any gasket material from the crankcase surface.

- *
 • Be careful not to drop foreign matters into the crankcase.



Install the piston, piston pin and a new piston pin clip.

- *
 • Position the piston "IN" mark on the intake valve side.
 • Place a clean shop towel in the crankcase to keep the piston pin clip from falling into the crankcase.

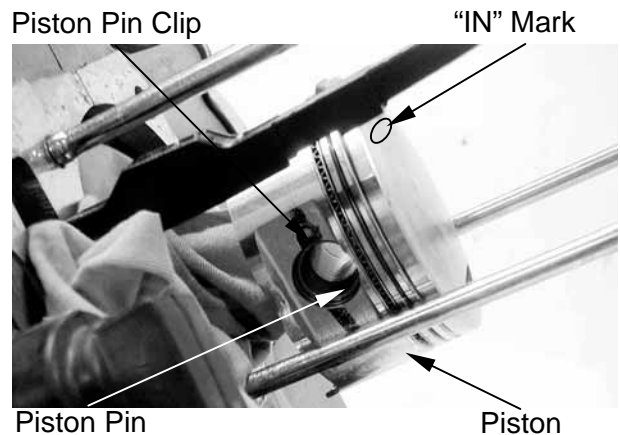

CYLINDER INSTALLATION

Install the dowel pins and a new cylinder gasket on the crankcase.

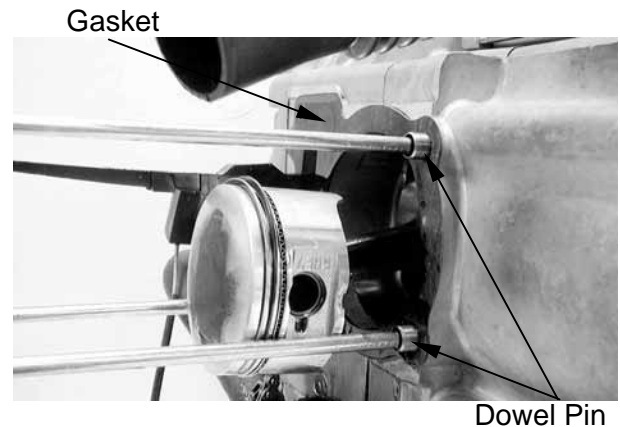

Coat the cylinder bore, piston and piston rings with clean engine oil.
Carefully lower the cylinder over the piston by compressing the piston rings.

- *
 • Be careful not to damage or break the piston rings.
 • The piston ring end gaps should not be parallel with or at 90° to the piston pin.

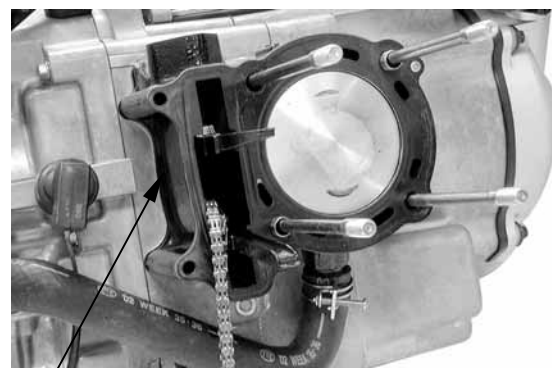

7. CYLINDER/PISTON

Install the cam chain guide.

- * • Insert the tab on the cam chain guide into the cylinder groove.

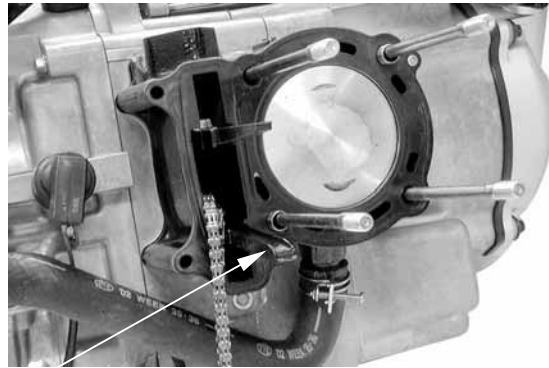

Cam Chain Guide

Install the cylinder head gasket and dowel pins.

Connect the water hose to the cylinder.

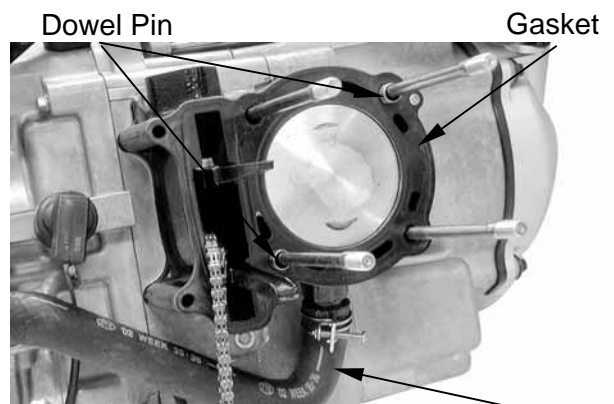

Water Hose

Install the cylinder head. (⇒chapter 6)
Tighten the cylinder base bolt.

