

PIAGGIO WOULD LIKE TO THANK YOU

for choosing one of its products. We have prepared this manual to help you to get the very best from your vehicle. Please read it carefully before riding the vehicle for the first time. It contains information, tips and precautions for using your vehicle. It also describes features, details and devices to assure you that you have made the right choice. We believe that if you follow our suggestions, you will soon get to know your new vehicle and it will serve you well for a long time to come. This booklet forms an integral part of the vehicle; should the vehicle be sold, it must be transferred to the new owner.

Beverly 300ie



The instructions given in this booklet are intended to provide a clear, simple guide to using your scooter; this booklet also details routine maintenance procedures and regular checks that should be carried out on the vehicle at an **authorised Dealer or Service Centres**. The booklet also contains instructions for simple repairs. Any operations not specifically described in this booklet require the use of special tools and/or particular technical knowledge: to carry out these operations, refer to any **authorised Dealer or Service Centres**.



Personal safety

Failure to completely observe these instructions will result in serious risk of personal injury.



Safeguarding the environment

Sections marked with this symbol indicate the correct use of the vehicle to prevent damaging the environment.



Vehicle intactness

The incomplete or non-observance of these regulations leads to the risk of serious damage to the vehicle and sometimes even the invalidity of the guarantee.

The signs that you see on this page are very important. They are used to highlight parts of the booklet that should be read with particular care. The different symbols are used to make each topic in the manual simple and quick to locate.

INDEX

VEHICLE	7	Stopping the engine.....	33
Dashboard.....	9	Stand.....	33
Analogue instrument panel.....	10	Automatic transmission.....	34
Digital lcd display.....	11	Safe driving.....	35
MODE button.....	12	MAINTENANCE	39
Key switch.....	12	Engine oil level.....	40
Locking the steering wheel.....	13	Engine oil level check.....	40
Releasing the steering wheel.....	13	Engine oil top-up.....	41
Switch direction indicators.....	14	Warning light (insufficient oil pressure).....	41
Horn button.....	14	Engine oil change.....	42
Light switch.....	15	Hub oil level.....	43
Start-up button.....	15	Tyres.....	45
Engine stop button.....	16	Spark plug dismantlement.....	47
The immobilizer system.....	16	Removing the air filter.....	48
Keys.....	16	Air filter cleaning.....	48
Immobilizer device enabled indicator led.....	17	Cooling fluid level.....	49
Operation.....	18	Checking the brake oil level.....	51
Programming the immobilizer system.....	19	Braking system fluid top up.....	51
Accessing the fuel tank.....	20	Battery.....	54
Power supply socket.....	21	Use of a new battery.....	55
Opening the saddle.....	21	Long periods of inactivity.....	55
Identification.....	22	Fuses.....	56
Rear top box opening.....	23	Lamps.....	59
Bag clip.....	24	Front light group.....	60
USE	25	Headlight adjustment.....	62
Checks.....	26	Front direction indicators.....	63
Refuelling.....	26	Rear optical unit.....	64
Tyre pressure.....	28	Number plate light.....	65
Shock absorbers adjustment.....	29	Helmet compartment lighting bulb.....	65
Running in.....	30	Rear-view mirrors.....	65
Starting up the engine.....	31	Front and rear disc brake.....	66
Precautions.....	32	Puncture.....	67
Difficult start up.....	32	Periods of inactivity.....	68

Cleaning the vehicle.....	68
Troubleshooting.....	70
TECHNICAL DATA.....	73
Toolkit.....	78
SPARE PARTS AND ACCESSORIES.....	79
Warnings.....	80
SCHEDULED MAINTENANCE.....	83
Scheduled servicing table.....	84

Beverly 300ie



PIAGGIO®



**Chap. 01
Vehicle**

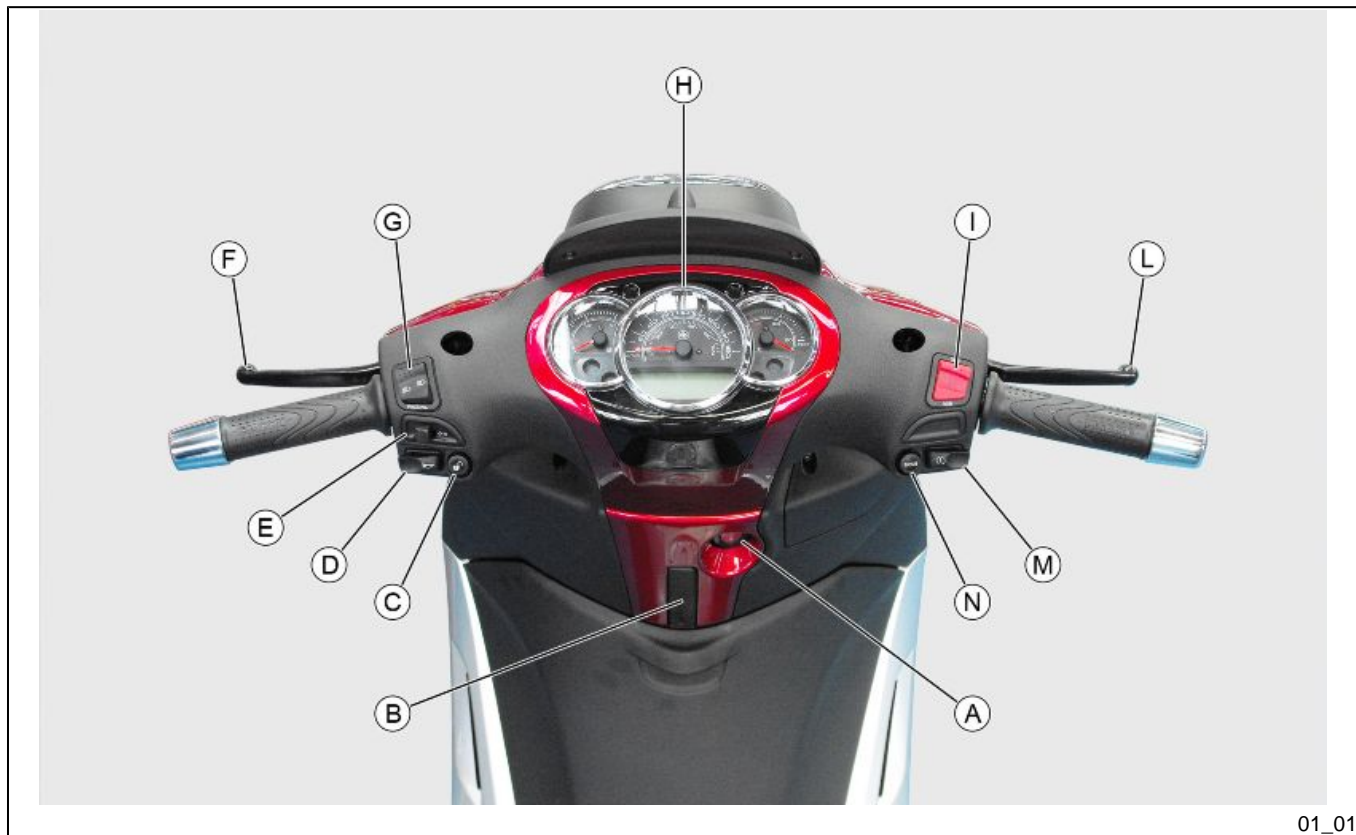

Dashboard (01_01)

A = Ignition key-switch

B = Bag hook

C = Saddle opening button

D = Horn button

E = Turn indicator switch

F = Rear brake lever

G = Light switch with passing

H = Instrument panel

I = Emergency stop switch RUN-OFF

L = Front brake lever

A = Starter button

N = MODE button

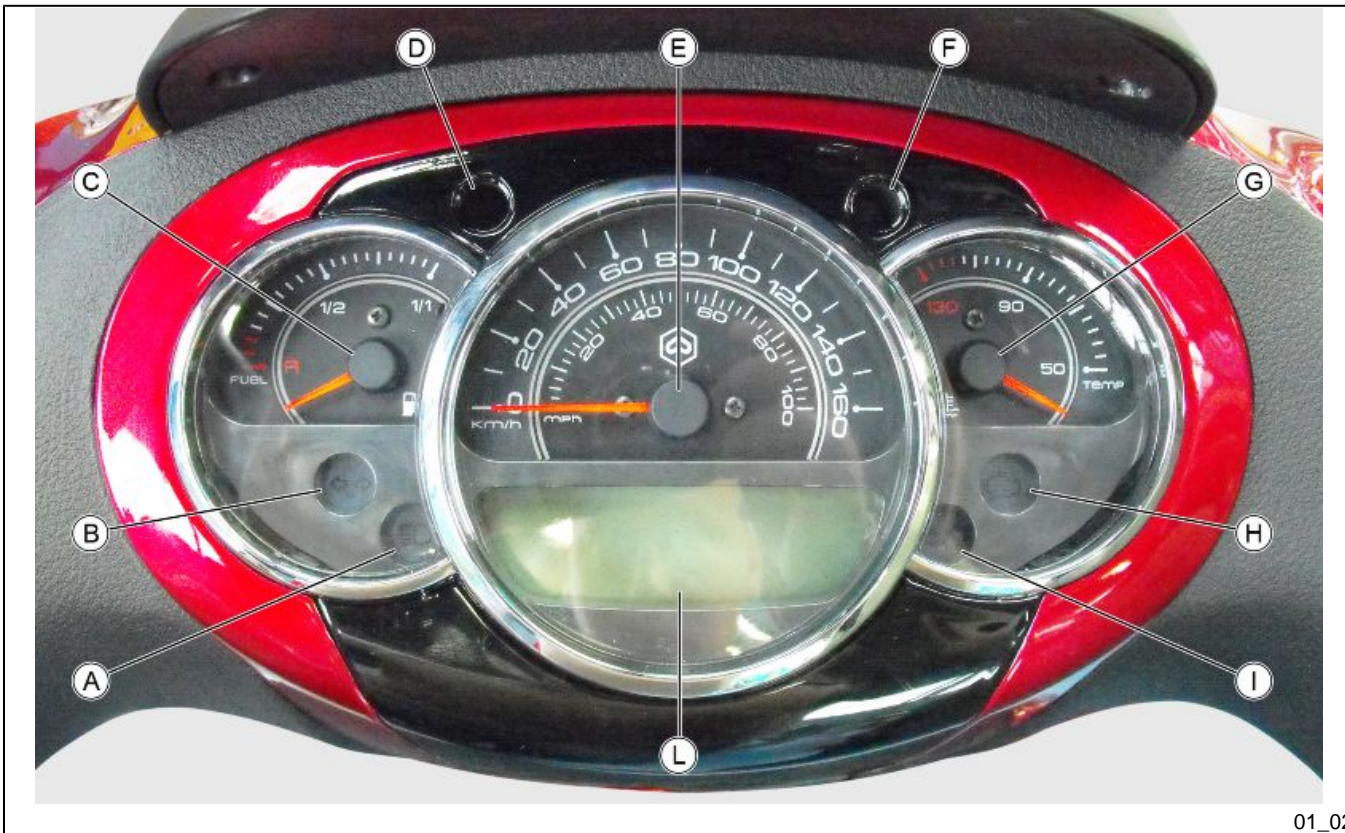

01_02

Analogue instrument panel (01_02)

A= High beam warning light

- B** = Turn indicator warning lights
- C** = Fuel gauge
- D** = Low fuel warning light
- E** = Speedometer
- F** = Immobiliser LED
- G** = Coolant temperature gauge
- H** = Engine control telltale light
- I** = Engine oil pressure warning light
- L** = Digital display

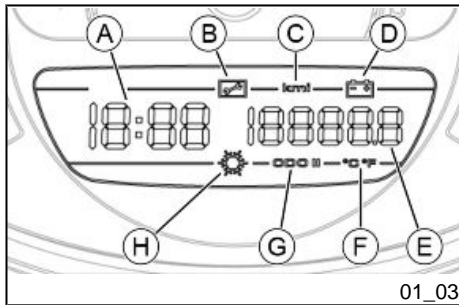

Digital lcd display (01_03)

- A** = Clock - date
- B** = «SERVICE» icon
- C** = Kilometre-mile indicator
- D** = State of battery charge icon
- E** = Odometer indicator, partial odometer I and II, state of battery charge and cyclically selectable ambient temperature with the «MODE» button
- F** = Ambient temperature indicator in degrees Celsius or Fahrenheit
- G** = Indicator «ODO», «ODO I» or «ODO II»
- H** = Low ambient temperature icon

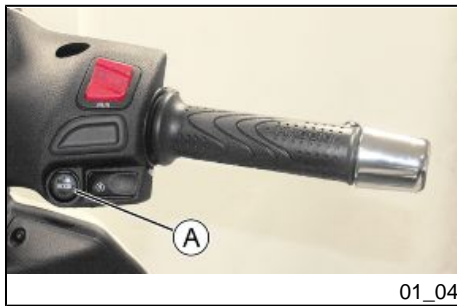

MODE button (01_04)

Pushing the **MODE** button «**A**» for less than a second displays the following sequence of functions:

- Total Odometer «**ODO**»
- Partial Odometer «**ODO I**»
- Partial Odometer «**ODO II**»
- State of battery charge
- Ambient temperature «°»

To reset the trip odometer, move «**ODO I**» or «**ODO II**» and press for more than three seconds the button **MODE** «**A**».

Key switch (01_05)

Ignition key «**A**» is located on the front leg shield back plate near the bag hook.



SWITCH POSITIONS

ON «**1**»: Ready to start position, non-extractable key, mechanical antitheft device disabled.

OFF «**2**»: Ignition disabled, extractable key, mechanical antitheft device disabled.

LOCK «**3**»: Ignition disabled, extractable key, mechanical antitheft device enabled.

Locking the steering wheel (01_06)

Turn the handlebar to the left (as far as it will go), turn the key to «**LOCK**» and remove the key.



01_06

Releasing the steering wheel (01_07)

Reinsert the key and turn it to «**OFF**».



01_07

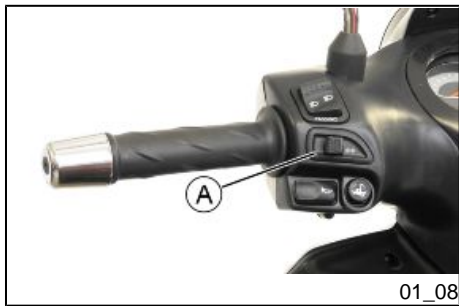

Switch direction indicators (01_08)

Move switch «A» to the left to indicate a left turn; move switch «A» to the right to indicate a right turn. Push the central part of switch «A» to deactivate the turn indicators.

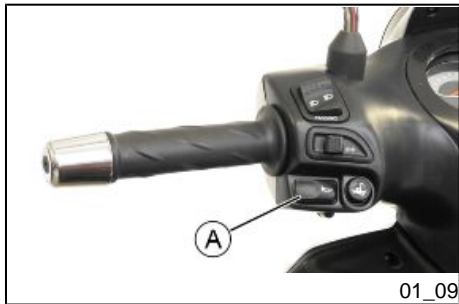

Horn button (01_09)

Press the «A» button to sound the horn.

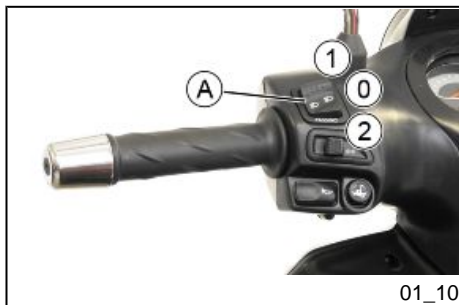

Light switch (01_10)

When the light switch «A» is in position «0» the low-beam light is ON; when it is in position «1» the high-beam light is ON. If the light switch «A» is pressed when set to «2», the high-beam light flashing is activated. The switch goes back to «0» automatically.

CAUTION



DO NOT CARRY ANY GARMENTS ON THE FRONT HEADLIGHT ASSEMBLY. THIS MAY CAUSE BULBS TO OVERHEAT AND THEREFORE ABNORMAL WEAR.

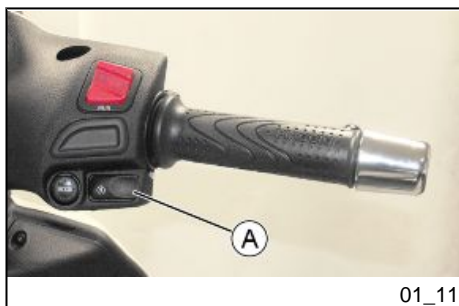

Start-up button (01_11)

Starter button «A». To start the vehicle, refer to the "starter motor" section.

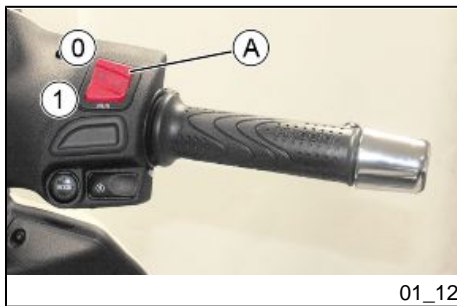

Engine stop button (01_12)

The engine can be started when the emergency stop switch «**A**» is in position «**1**» **RUN**; if the emergency stop switch «**A**» is in position «**0**» **OFF** the engine cannot be started or it stops if it was running.

The immobilizer system

In order to enhance theft protection, the vehicle is equipped with a «**PIAGGIO IMMOBILIZER**» electronic engine locking device that is activated automatically when the ignition switch is removed. Upon start-up, the «**PIAGGIO IMMOBILIZER**» system checks the starter key, and only if this key is recognised will the Immobiliser system allow the vehicle to be started.

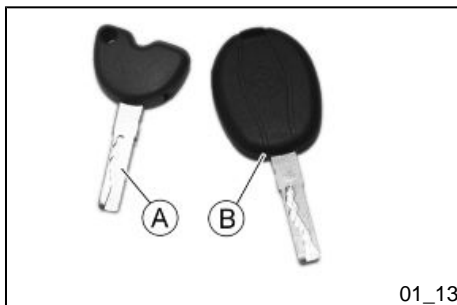

Keys (01_13, 01_14, 01_15)

Two types of keys are supplied together with the vehicle.

Key «**A**» is the «**MASTER**» key.

Only a single copy of this key is supplied, which is necessary to program all your other keys and for your dealer to perform some maintenance operations. For this reason it is advised that it be used only in exceptional circumstances.

The key «**B**» (single copy supplied) is used for regular operations such as:

- Engine starter
- Opening fuel tank cap

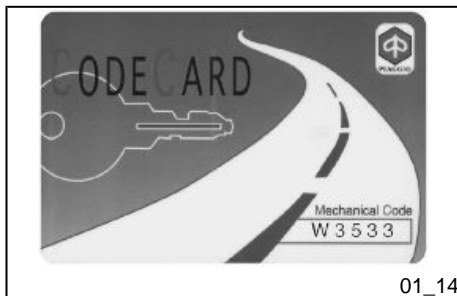

01_14

Together with the two keys, you will be given a CODE CARD bearing the same code imprinted onto the two keys.

WARNING



LOSING THE MASTER KEY PREVENTS ANY FURTHER REPAIR OF THE "PIAGGIO IMMOBILISER" SYSTEM AND OF THE ENGINE CONTROL UNIT.

WARNING



KEEP THE "CODE CARD" AND THE MASTER KEY IN A SAFE PLACE (NOT IN THE VEHICLE).

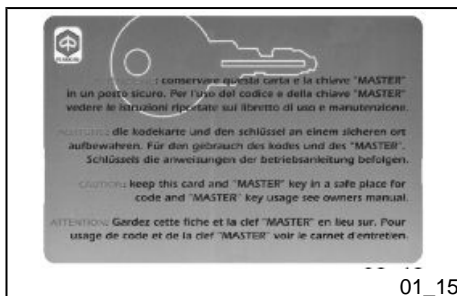

01_15

Immobilizerdevice enabled indicator led (01_16)

The activation of the «PIAGGIO IMMOBILISER» system is signalled by the a flashing indicator «A».

In order to reduce battery discharge, the indicator LED turns off automatically after 48 hours of uninterrupted functioning.

Should the system fail, different LED flashing patterns will provide the **Authorised Service Centre** with information on the type of fault detected.



01_16

Operation

Each time the ignition key «**B**» is removed while in the «**OFF**» or «**LOCK**» positions, the protection system activates the engine lock. Turning the ignition key «**B**» to «**ON**» disables the engine lock, provided that the safety system recognises the code transmitted by the key. If the code is not recognised, turn the ignition key «**B**» first to «**OFF**» and then back to «**ON**» again; if lock persists, try again using the «**A**» MASTER key. If the engine cannot be started, contact an **Authorised Service Centre**, which is provided with the electronic equipment required to detect and repair the system.

When the supplementary starter keys are required, remember that the all the keys, whether new or existing, should be programmed.

Contact an **Authorised Service Centre** and bring the «**A**» MASTER key and all «**B**» starter keys that you own.

The codes of starter keys not submitted for the new programming procedure are deleted from the memory. Any lost starter keys will therefore not be enabled to start the engine.

WARNING



EACH KEY HAS ITS OWN AND UNIQUE CODE, WHICH MUST BE STORED IN THE SYSTEM CONTROL UNIT MEMORY.

VIOLENT SHOCKS MAY AFFECT THE ELECTRONIC COMPONENTS OF THE KEY.

IF THE VEHICLE IS SOLD, THE MASTER-HANDGRIP KEY (AS WELL AS THE OTHER STARTER KEYS) AND THE «CODE CARD» MUST ALSO BE TRANSFERRED TO THE NEW OWNER.

Programming the immobilizer system (01_17)

Below is described the procedure to follow for programming the **PIAGGIO IMMOBILISER** system and/or for storing other key codes. The programming procedure should be carried out with the engine stop switch set to **«RUN»**.

START PROCEDURE

Insert the **«MASTER»** key **«A»** into the ignition switch (in **«OFF»**) and turn it to **«ON»**. After 1 - 3 seconds, turn the key to **«OFF»** again and pull it out.

INTERMEDIATE STAGE

After extracting the **«MASTER»** key **«A»**, insert, within ten seconds, the key that is going to be programmed **«B»** and turn it immediately to **«ON»**. After 1-3 seconds, turn the key to **«OFF»** again and pull it out. In this way, a maximum of 5 keys can be programmed by repeating the above procedure and keeping the indicated times.

FINAL STAGE

After extracting the key to be programmed **«B»**, insert the **«MASTER»** key **«A»** again and turn it to **«ON»** (perform this operation within the 10 seconds following the extraction of the previous key). Leave it in this position for 1 to 3 seconds and return it to **«OFF»**.

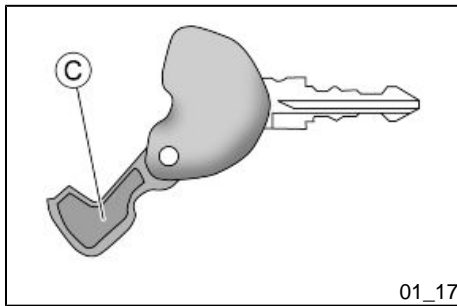

01_17

CORRECT PROGRAMMING CHECK PHASE

Insert the «MASTER» key «A» disabling the transponder «C» (i.e., by tilting the key cap by 90°), and turn the key to «ON». Perform the engine starter operation. Ensure that the engine does not start. Insert the programmed key «B» and repeat the starter operation. Check that engine starts.

WARNING



SHOULD YOU START THE ENGINE WITH THE MASTER KEY (WITH TRANSPONDER OFF) OR IN THE EVENT OF WRONG OPERATION DURING PROGRAMMING, REPEAT THE PROCEDURE FROM THE BEGINNING.

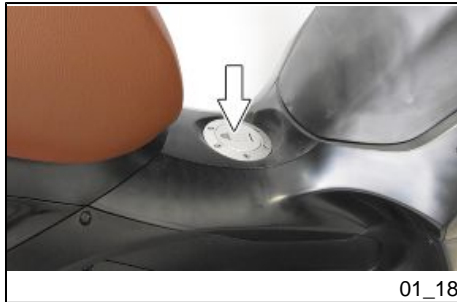

01_18

Accessing the fuel tank (01_18)

Raise the lock protection tab on the fuel tank cap. Insert the key and turn anticlockwise to remove the cap.



01_19

Power supply socket (01_19)

There is a plug socket inside the front case.

The plug socket may be used for external consumers (mobile phone, inspection light, etc.).

CAUTION



PROLONGED USE OF THE PLUG SOCKET MAY RESULT IN PARTIAL DISCHARGE OF THE BATTERY

Electric characteristic

Plug socket

12 V - 180 W MAX



01_20

Opening the saddle (01_20, 01_21)

With the key in position «OFF» or «ON» or with the engine ON, you can electrically open the saddle by pressing button «A». If the electric opening does not work, use the emergency lever B.



01_21

Identification (01_22, 01_23)

Identification registration numbers are made up of a prefix and a number embossed on the chassis and on the engine. These numbers must always be quoted when ordering spare parts. We recommend checking that the chassis registration number stamped on the vehicle corresponds with that on the vehicle documentation.

CAUTION



BE REMINDED THAT ALTERING IDENTIFICATION REGISTRATION NUMBERS CAN LEAD TO SERIOUS PENAL SANCTIONS (IMPOUNDING OF THE VEHICLE, ETC.).



01_22

Chassis number

To read the chassis number, remove the port **A** in the front case.

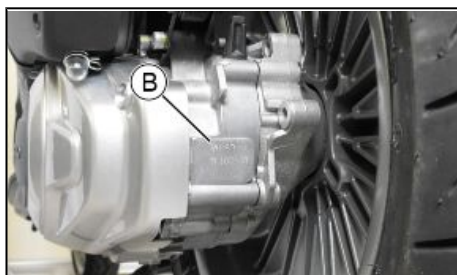

01_23

Engine number

The engine number «**B**» is stamped near the rear left shock absorber lower support.



01_24

Rear top box opening (01_24)

Insert the key into the switch and press down until the glove compartment opens. In the event that the switch is in «**LOCK**», turn the key to «**OFF**» or «**ON**» before pressing it.

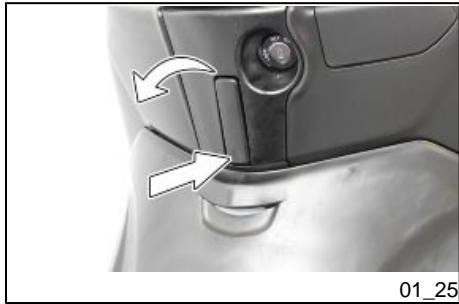

Bag clip (01_25)

To use retractile bag hook mounted on the leg shield back plate, it is necessary to turn it towards the rear part of the vehicle pressing where indicated by the arrow.

Beverly 300ie



PIAGGIO®



Chap. 02
Use

Checks

Before using the vehicle, check:

1. That there is enough fuel in the fuel tank.
2. Front and rear brake fluid level
3. That tyres are properly inflated.
4. The correct functioning of the tail lights, the headlight, and the turn indicators.
5. The correct functioning of front and rear brakes.
6. The oil level in the gearcase.
7. Engine oil level.
8. The coolant level

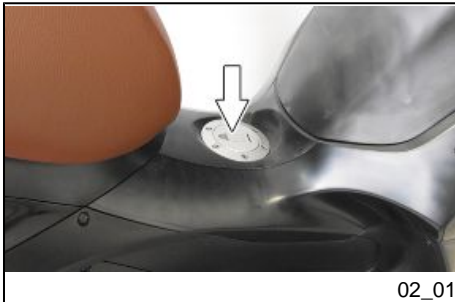

Refuelling (02_01)

Raise the lock protection tab on the fuel tank cap. Insert the key and turn anticlockwise to remove the cap.

WARNING



SWITCH OFF THE ENGINE BEFORE REFUELLING WITH PETROL.

PETROL IS HIGHLY INFLAMMABLE.

DO NOT SMOKE AND KEEP NAKED FLAMES AT A DISTANCE: FIRE HAZARD.

DO NOT INHALE FUEL FUMES.

DO NOT ALLOW PETROL TO COME INTO CONTACT WITH HOT ENGINE OR ANY PLASTIC PARTS.

CAUTION



DO NOT USE THE VEHICLE TO THE COMPLETE EXHAUSTION OF THE FUEL; SHOULD THIS OCCUR, DO NOT ATTEMPT TO START THE ENGINE. TURN THE IGNITION SWITCH TO «OFF» AND TOP-UP THE TANK AS SOON AS POSSIBLE. FAILURE TO FOLLOW THESE GUIDELINES COULD DAMAGE THE FUEL PUMP AND/OR THE CATALYTIC CONVERTER.

CAUTION



CLEAN IMMEDIATELY THE PAINTED OR PLASTIC SURFACES THAT COME INTO CONTACT WITH THE FUEL TO AVOID LOSS OF THEIR SHINE OR ALTERATION OF THEIR MECHANICAL CHARACTERISTICS.

Characteristic

Fuel tank

13 | ± 1

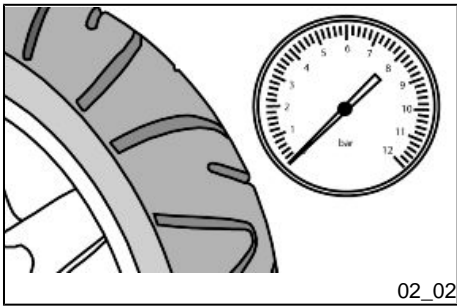

Tyre pressure (02_02)

Check tyre pressure and wear periodically as indicated in the scheduled maintenance table. Tyres feature wear indicators; replace tyres as soon as these indicators become visible on the tyre tread. Also check that the tyres do not show signs of splitting at the sides or irregular tread wear; if this occurs, go to an authorised workshop or at least to a workshop equipped to replace tyres.

CAUTION



TYRE PRESSURE SHOULD BE CHECKED WHEN TYRES ARE COLD. INCORRECT TYRE PRESSURE CAUSES ABNORMAL TYRE WEAR AND MAKES RIDING DANGEROUS.

TYRES MUST BE REPLACED WHEN THE TREAD REACHES THE WEAR LIMITS SET FORTH BY LAW.

TYRE INFLATION PRESSURE

Front tyre pressure (with passenger)	2.2 bar (2.2 bar)
Rear tyre pressure (with passenger)	2.4 bar (2.6 bar)

TYRES

Front tyre	110/70 - Tubeless 16" 52S or 52P
Rear tyre	140/70 - Tubeless 14" 68P or 68S

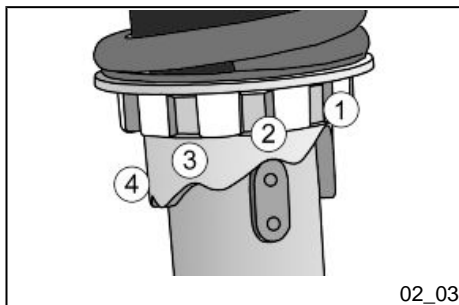

Shock absorbers adjustment (02_03, 02_04)

The preloading of the springs can be adjusted to 4 positions acting on the ring nut located in the lower part of the shock absorbers with the specific spanner supplied.

Position 1: minimum preload: rider only

Position 2 medium preloading: rider only

Position 3 medium preloading: rider and passenger

Position 4: maximum preloading: rider, passenger, and luggage.

In order to carry out this operation you will need to use the specific spanner in the kit. Spring preloading increases by turning the ring nut towards «A», but decreases if the ring nut is turned towards «B».

CAUTION



RIDING THE VEHICLE WITH THE SPRING PRELOADING NOT CORRECTLY SET FOR THE RIDER AND POSSIBLE PASSENGER, COULD REDUCE THE COMFORT OF THE RIDE AND THE PRECISION OF THE STEERING.

WARNING



WE RECOMMEND WEARING GLOVES WHILE CARRYING OUT THIS OPERATION IN ORDER TO AVOID INJURIES.



WARNING

IT IS ABSOLUTELY FORBIDDEN TO ADJUST THE PRELOAD DIFFERENTLY ON THE TWO SHOCK ABSORBERS

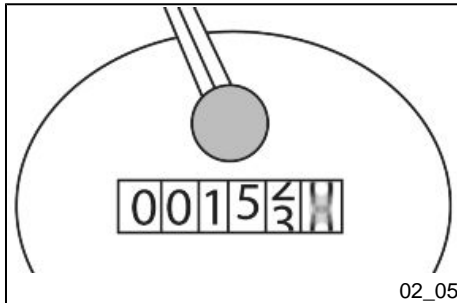
**Running in (02_05)**

DURING THE FIRST 1000 KM DO NOT RIDE THE VEHICLE OVER 80% OF ITS MAX. SPEED. AVOID OPENING THE THROTTLE GRIP COMPLETELY OR KEEPING A CONSTANT SPEED ALONG LONG SECTIONS OF ROAD. AFTER THE FIRST 1000 KM INCREASE SPEED PROGRESSIVELY, IF POSSIBLE, UNTIL THE MAXIMUM PERFORMANCE IS OBTAINED.

CAUTION

IN ORDER TO AVOID DAMAGING THE VEHICLE, PLEASE COMPLY WITH THE RULES LISTED ABOVE.

Starting up the engine (02_06, 02_07, 02_08)

The vehicle is equipped with an ignition prevention system controlled by the side stand.

The engine cannot be started if the side stand is lowered.

If the engine is on, it will turn itself off if the side stand is lowered.

To start the engine it is necessary, before pressing the starter button, to pull and keep pulled the front or rear brake lever, which activates the appropriate switch allowing start-up.

- Rest the vehicle on its centre stand, making sure that the rear wheel is not touching the ground.

- Keep the throttle grip at idle speed.

- Insert the key into the ignition switch «A» and turn it to «ON».

- Make sure that the emergency stop switch «B» is in position «RUN» and the side stand is up and not engaged.

- Pull either the front, «C» or rear «D» brake lever and then press the starter button «E».

WARNING



THE AUTOMATIC TRANSMISSION MAKES THE REAR WHEEL TURN EVEN WHEN THE THROTTLE GRIP IS SLIGHTLY TWISTED. RELEASE THE BRAKE CAREFULLY AFTER STARTING, AND THEN ACCELERATE GRADUALLY.

CAUTION



DO NOT START-UP THE ENGINE IN CLOSED AREAS BECAUSE EXHAUST GASES ARE TOXIC.



02_06

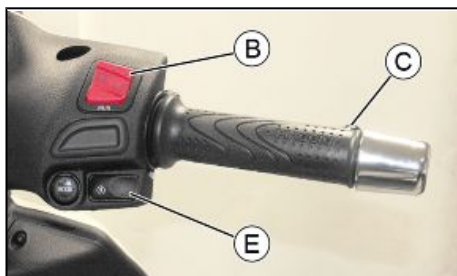

02_07



02_08

Precautions

CAUTION



NEVER STRESS THE ENGINE AT LOW TEMPERATURES IN ORDER TO AVOID POSSIBLE DAMAGE. BE CAREFUL NEVER TO EXCEED THE MAXIMUM SPEED WHILE RUNNING DOWNHILL, IN ORDER TO AVOID DAMAGING THE ENGINE. IN ANY CASE, IN ORDER TO PRESERVE THE ENGINE FROM PROLONGED OVERREVVING, THE REVOLUTION LIMITER WILL BE ACTIVATED IF THE ENGINE SPEED EXCEEDS THE ESTABLISHED THRESHOLD.

WARNING



AFTER A LONG DISTANCE COVERED AT THE MAXIMUM SPEED, DO NOT STOP THE ENGINE IMMEDIATELY, BUT LET IT RUN AT IDLE FOR A FEW SECONDS.

Difficult start up

In the rare case of a flooded engine, and in order to facilitate start-up, try putting the vehicle into motion with the throttle slightly open. It is however necessary, once the engine is started, to take your vehicle to an **Authorised Service Centre** to determine the cause of this problem and to re-establish the vehicle proper functioning.



02_09

Stopping the engine (02_09)

Fully untwist the throttle grip, then rotate the key in the switch «A » to «KEY OFF» (extractable key).

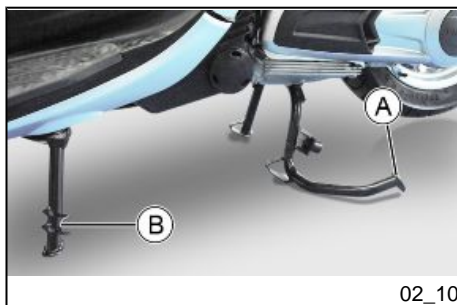

02_10

Stand (02_10)

Centre stand

Push with your foot on the centre stand's fork "A" while lifting the vehicle backward, using the handlebar.

Side stand

Push with your foot on the fork of the stand «B» to bring it into open position, while lifting the vehicle at the same time.

WARNING



THE SIDE STAND CAUSES THE ENGINE TO TURN ITSELF OFF WHENEVER IT IS LOWERED.

WARNING

TAMPERING MAY CAUSE SERIOUS ENGINE MALFUNCTION.

CAUTION

DUE TO THE HIGH TEMPERATURES THE CATALYTIC CONVERTER CAN REACH, ALWAYS TAKE CARE, WHEN PARKING THE VEHICLE, THAT THE SILENCER DOES NOT COME INTO CONTACT WITH FLAMMABLE MATERIALS, TO AVOID SERIOUS BURNS.

CAUTION

DO NOT SHUT OFF THE ENGINE WHILE THE VEHICLE IS MOVING. UNBURNED FUEL COULD ENTER THE CATALYTIC CONVERTER AND BURN, CAUSING THE CONVERTER TO OVERHEAT AND POSSIBLY DESTROYING IT.

Automatic transmission

To ensure simple, pleasurable riding, the vehicle is equipped with automatic transmission with regulator and centrifugal clutch. The system is designed to provide the best performance (acceleration and consumption) while driving on both flat roads and uphill.

If you have to stop on an uphill slope (traffic lights, traffic jam, etc.) **only use the brake to keep the vehicle still, leaving the motor running at idling speed. Using the engine to keep the vehicle still can cause the clutch to overheat, due to the friction of the clutch mechanism itself against the capstan.**

It is therefore recommended to avoid conditions of prolonged clutch slippage (other than those previously indicated) like driving uphill fully laden on steep slopes or starting off with driver and passenger at slopes greater than 25%.

Take the following precautions if the clutch overheats:

1. Do not continue riding in such conditions.
2. Let the clutch cool down with the engine at idle speed for a few minutes.



Safe driving (02_11)

Some simple tips are provided below that will enable you to use your vehicle on a daily basis, confidently and safely. Your skill and your mechanical knowledge are the basis of safe riding. We recommend trying out the vehicle in traffic-free zones to familiarise with it.

1. Before riding off, remember to put on your helmet and fasten it correctly.
2. Reduce speed on rough roads and ride with care.
3. After riding on a long stretch of wet road without using the brakes, braking can be poor at the beginning. Under these conditions, it is a good idea to operate the brakes from time to time.
4. Do not brake hard on wet, dirt or slippery road surfaces.
5. Avoid riding off by mounting the scooter when resting on the support. In any case, the rear wheel should not be turning when it comes into contact with the ground, in order to avoid abrupt departures.
6. When riding along roads covered by sand, mud, snow mixed with salt, etc. We recommend cleaning the brake disc frequently with a non-corrosive detergent in order to prevent corrosive particles from building up in the holes, which may cause early brake pad wear.

CAUTION

ALWAYS RIDE WITHIN YOUR LIMITS RIDING UNDER THE INFLUENCE OF ALCOHOL OR OTHER DRUGS AND CERTAIN MEDICINES IS EXTREMELY DANGEROUS.

CAUTION

IN ORDER TO PREVENT ANY ACCIDENTS RIDE VERY CAREFULLY AFTER ADDING ACCESSORIES AND WHILE CARRYING LUGGAGE. ADDING ACCESSORIES AND LUGGAGE CAN REDUCE THE VEHICLE'S STABILITY, PERFORMANCE AND SAFETY DURING USE.

WARNING

NEVER RIDE THE SCOOTER EQUIPPED WITH ACCESSORIES (TOP BOX AND/OR WINDSHIELD) AT A SPEED HIGHER THAN 100 km/h.

THE SCOOTER CAN BE RIDDEN AT A HIGHER SPEED WITHOUT THE ACCESSORIES MENTIONED BEFORE WITHIN THE LIMITS ESTABLISHED BY LAW.

IF THERE ARE ANY NON-PIAGGIO ACCESSORIES INSTALLED, OR AN ABNORMAL LOAD, OR IF THE SCOOTER IS NOT IN A GENERALLY GOOD CONDITION, OR WHENEVER WEATHER CONDITIONS DEMAND IT, SPEED SHOULD BE FURTHER REDUCED.

CAUTION

DO NOT ADJUST THE MIRRORS WHILE RIDING. THIS COULD CAUSE YOU TO LOOSE CONTROL OF THE VEHICLE.

CAUTION



ANY ELABORATION THAT MODIFIES THE VEHICLE'S PERFORMANCES, SUCH AS TAMPERING WITH ORIGINAL STRUCTURAL PARTS IS STRICTLY FORBIDDEN BY LAW, AND RENDERS THE VEHICLE NO LONGER CONFORMING TO THE APPROVED TYPE AND DANGEROUS FOR RIDING.

Beverly 300ie



PIAGGIO®



**Chap. 03
Maintenance**

Engine oil level

In 4-stroke engines, engine oil is used to lubricate the distribution elements, the bushes and the thermal group. **An insufficient quantity of oil can cause serious damage to the engine.** In all four-stroke engines, a loss of efficiency in oil performance and certain consumption should be considered normal. Consumption can particularly reflect the conditions of use (i.e. when driving at "full acceleration" all the time, oil consumption increases). The replacement frequencies provided for by the maintenance programme are defined, depending on the total contents of oil in the engine and average consumption measured following standardised methods.

In order to prevent any problems, we recommend checking oil level more frequently than indicated in the Scheduled Maintenance table or before setting off on long journeys. The scooter is, however, equipped with an oil pressure warning light on the instrument panel.



03_01

Engine oil level check (03_01, 03_02)

Every time the vehicle is used, visually inspect the level of the engine oil when the engine is cold (after **completely unscrewing** the oil cap/dipstick). The oil level should be somewhere between the MAX and MIN index marks on the level rod; «**A**»; while the oil is being checked, the vehicle must be resting on its centre stand on an even, horizontal surface.

If the check is carried out after the vehicle has been used, and therefore with a hot engine, the level line will be lower; in order to carry out a correct check, wait at least 10 minutes after the engine has been stopped so as to get the correct level.

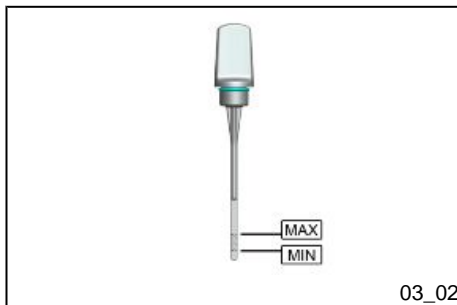

03_02

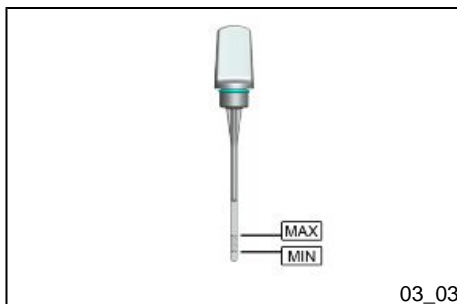

03_03

Engine oil top-up (03_03)

The oil should be topped up after having checked the level and in any case by adding oil **without ever exceeding the MAX. level**. The topping up of the level between the **MIN** and **MAX** implies a quantity of 400 cm³ of oil. As reported in the scheduled maintenance table, it is still expected to perform, at an **Authorised Service Centre**, a check and engine oil top-up.



03_04

Warning light (insufficient oil pressure) (03_04)

The vehicle is equipped with a warning light that comes on when the key is turned to «ON». However, this light should come off once the engine has been started. **If the light comes on while braking, at idle speed or while turning a corner, it is necessary to check the oil level and top it up if required. If after having topped-up the oil, the warning light still comes on while braking, at idle speed or while turning a corner, it will be necessary to take your vehicle to an Authorised Service Centre.**



03_05



03_06

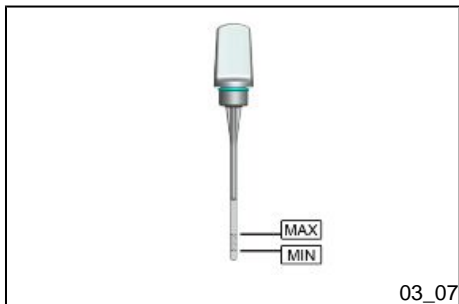

03_07

Engine oil change (03_05, 03_06, 03_07)

Have oil changed and the cartridge filter «C» replaced as indicated in the scheduled maintenance table at an **Authorised Service Centre**. The engine should be emptied by draining the oil through drainage plug «B» of the mesh filter on the flywheel side. In order to facilitate the oil drainage, loosen the cap/dipstick. Since a certain quantity of oil still remains in the circuit, add approx. $950 \div 1000 \text{ cm}^3$ of oil through the cap «A». Then start the engine, leave it running for a few minutes and shut it off: after 5 minutes, check the level and if necessary, top-up **without exceeding the MAX level**. The cartridge filter must be replaced at every oil change. For top-ups and changes, use new oil of the recommended type.

WARNING



RUNNING THE ENGINE WITH INSUFFICIENT LUBRICATION OR WITH INADEQUATE LUBRICANTS ACCELERATES THE WEAR AND TEAR OF THE MOVING PARTS AND CAN CAUSE IRRETRIEVABLE DAMAGE.

WARNING



EXCESSIVE OIL LEVEL AT TOP-UPS CAN LEAD TO SCALE FORMATION AND VEHICLE MALFUNCTION.

CAUTION



USED OILS CONTAIN SUBSTANCES HARMFUL TO THE ENVIRONMENT. FOR OIL CHANGE, CONTACT AN AUTHORISED SERVICE CENTRE WHICH IS EQUIPPED TO DISPOSE OF USED OILS IN AN ENVIRONMENTALLY FRIENDLY AND LEGAL WAY.

CAUTION

USING OILS OTHER THAN THOSE RECOMMENDED CAN SHORTEN THE LIFE OF THE ENGINE.

Recommended products**AGIP CITY HI TEC 4T**

Engine oil

SAE 5W-40, API SL, ACEA A3, JASO MA Synthetic oil

Hub oil level (03_08, 03_09)

Check the oil in the rear hub. To check the rear hub oil level, proceed as follows:

1. Rest the vehicle onto its centre stand, on level ground.
2. Unscrew the hub oil dipstick «**A**», dry it with a clean cloth. Reinsert it **and screw it fully into place**.
3. Pull out the dipstick to check that the hub oil level is slightly over the notch indicated by the arrow in the figure. This is the correct level and it must remain constant at all times.
4. Screw the dipstick back in, checking that it is locked in place.

N.B.

THE NOTCHES ON THE HUB OIL LEVEL DIPSTICK, EXCEPT THE ONE INDICATING THE MAX LEVEL, REFER TO OTHER MODELS BY THE MANUFACTURER AND HAVE NO SPECIFIC FUNCTION FOR THIS MODEL.

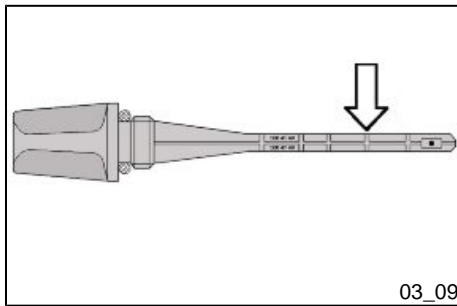

03_08

**CAUTION**

RIDING THE VEHICLE WITH INSUFFICIENT HUB LUBRICATION OR WITH CONTAMINATED OR IMPROPER LUBRICANTS ACCELERATES THE WEAR AND TEAR OF THE MOVING PARTS AND CAN CAUSE SERIOUS DAMAGE.

CAUTION

USED OIL CAN HARM THE ENVIRONMENT. COLLECTION AND DISPOSAL SHOULD BE CARRIED OUT IN COMPLIANCE WITH REGULATIONS IN FORCE.

CAUTION

AN EXCESSIVE QUANTITY OF OIL CAN LEAD TO SPILL OVER, WHICH MAY CAUSE THE ENGINE AND THE WHEEL TO GET DIRTY.

CAUTION

WHEN REPLACING THE HUB OIL DO NOT LET THE OIL COME INTO CONTACT WITH THE REAR BRAKE DISC.

CAUTION

FOR OIL REPLACEMENT, CONTACT ANY AUTHORISED SERVICE CENTRE AS THEY ARE EQUIPPED TO DISPOSE OF USED OILS IN AN ENVIRONMENTALLY FRIENDLY AND LEGAL WAY.

Recommended products

AGIP ROTRA 80W-90

Rear hub oil

SAE 80W/90 Oil that exceeds the requirements of API GL3 specifications

Characteristic

Transmission oil

250 cm³

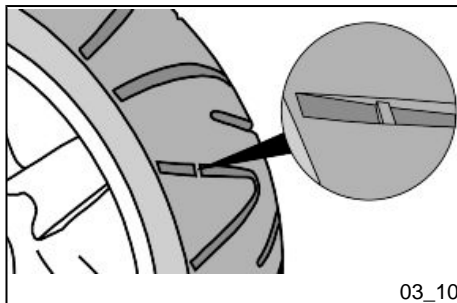

Tyres (03_10)

Check tyre pressure and wear periodically as indicated in the scheduled maintenance table. Tyres feature wear indicators; replace tyres as soon as these indicators become visible on the tyre tread. Also check that the tyres do not show signs of splitting at the sides or irregular tread wear; if this occurs, go to an authorised workshop or at least to a workshop equipped to replace tyres.

CAUTION



TYRE PRESSURE SHOULD BE CHECKED WHEN TYRES ARE COLD. INCORRECT TYRE PRESSURE CAUSES ABNORMAL TYRE WEAR AND MAKES RIDING DANGEROUS.

TYRES MUST BE REPLACED WHEN THE TREAD REACHES THE WEAR LIMITS SET FORTH BY LAW.

WARNING



THE WHEELS FITTED WITH TYRES SHOULD ALWAYS BE BALANCED. RIDING THE VEHICLE WITH VERY LOW TYRE PRESSURE OR WITH INCORRECTLY BALANCED TYRES CAN LEAD TO DANGEROUS STEERING VIBRATIONS.

TYRES

Front tyre	110/70 - Tubeless 16" 52S or 52P
Rear tyre	140/70 - Tubeless 14" 68P or 68S

TYRE INFLATION PRESSURE

Front tyre pressure (with passenger)	2.2 bar (2.2 bar)
Rear tyre pressure (with passenger)	2.4 bar (2.6 bar)

Spark plug dismantlement (03_11, 03_12)

Proceed as follows:

- Remove the case that grants access to the spark plug located on the right side fairing by unscrewing the indicated screw.
- Disconnect cap «A» from the spark plug HV cable by turning it clockwise until releasing it from the retainer.
- Unscrew the spark plug using the wrench supplied.
- When refitting, place the spark plug into the hole at the corresponding angle and finger tighten it as far as it will go. Use the wrench only to tighten it.
- Place cap «A» fully over the spark plug, making sure it is in the retainer again.

WARNING



SPARK PLUG MUST BE REMOVED WHEN THE ENGINE IS COLD. REPLACE THE SPARK PLUG AS INDICATED IN THE SCHEDULED MAINTENANCE TABLE. THE USE OF ELECTRONIC CENTRAL UNITS AND OF NON-COMPLIANT ELECTRONIC IGNITIONS OR SPARK PLUGS OTHER THAN THOSE PRESCRIBED MAY SERIOUSLY DAMAGE THE ENGINE.

N.B.

USE OF SPARK PLUGS OTHER THAN THE INDICATED TYPE OR UNSHIELDED SPARK PLUG CAPS CAN LEAD TO FAULTS IN THE VEHICLE 'S ELECTRICAL SYSTEM.



03_11

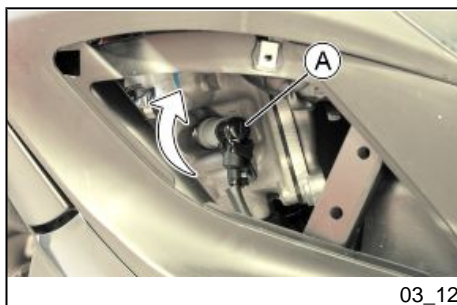

03_12



03_13

Removing the air filter (03_13, 03_14)

To access the air filter:

- Unscrew the three screws «A» and remove the air filter cover.
- Unscrew the other six screws «B» and remove the air filter cover.

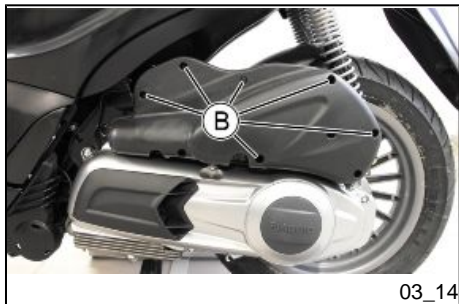

03_14



03_15

Air filter cleaning (03_15)

1. Wash the sponge with water and neutral soap.
2. Dry it with a clean cloth and small blasts of compressed air.
3. Soak the sponge with a mixture of 50% petrol and 50% specified oil.
4. Gently squeeze the filter element without twisting it, let it drip and then refit it.

CAUTION

IF THE VEHICLE IS USED ON DUSTY ROADS IT IS NECESSARY TO CARRY OUT MAINTENANCE CHECKS OF THE AIR FILTER MORE OFTEN TO AVOID DAMAGING THE ENGINE.

Recommended products**AGIP FILTER OIL**

Oil for air filter sponge

Mineral oil with specific additives for increased adhesiveness

**Cooling fluid level (03_16, 03_17, 03_18, 03_19)**

Engine cooling is carried out by a forced-circulation coolant system. The coolant consists of a mixture 50% de-ionised water and 50% glycol ethylene-based antifreeze solution with corrosion inhibitors. The coolant supplied with the scooter is already mixed and ready for use.

For proper engine functioning, make sure that the temperature of the coolant remains in the middle zone of the corresponding gauge. If the needle of the gauge enters the red zone, stop the engine, let it cool down and check the coolant level; if the level is OK, contact an **Authorised Service Centre**.

Check coolant when the engine is cold and as indicated in the scheduled maintenance tables, following the steps below.

1. Set the vehicle upright on the stand and remove the cover by undoing screw «**A**».
2. Remove the expansion tank cover «**B**» by turning it anticlockwise.
3. Look inside the expansion tank and check that fluid level is always between the «**MIN**» and «**MAX**» levels.
4. Top-up the fluid when it is close to the minimum mark.



03_17



03_18

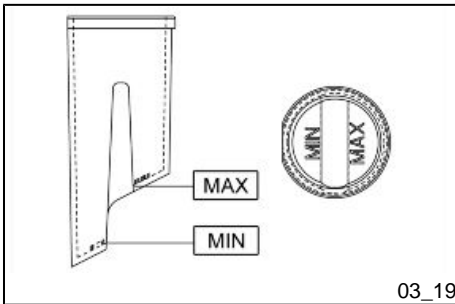

03_19

If the level is not correct, proceed to top-up when the engine is cold. If the coolant needs to be topped up frequently or the expansion tank is completely dry, check the cooling system to find the cause of the problem. It is therefore essential to have the cooling system checked at an **Authorised Service Centre**.

Replace coolant as indicated in the scheduled maintenance table. Take your vehicle to an **Authorised Service Centre** for this operation.

WARNING



TO AVOID THE RISK OF SCALDING, DO NOT UNSCREW THE EXPANSION TANK COVER WHILE THE ENGINE IS STILL HOT.

WARNING



IN ORDER TO AVOID HARMFUL FLUID LEAKS WHILE RIDING, IT IS IMPORTANT TO MAKE SURE THAT THE LEVEL DOES NOT EXCEED THE REFERENCE TONGUE TOO MUCH.

TO ENSURE CORRECT ENGINE OPERATION, KEEP THE RADIATOR GRILLE CLEAN.

Recommended products

AGIP PERMANENT SPECIAL

coolant

Monoethylene glycol-based antifreeze fluid, CUNA NC 956-16

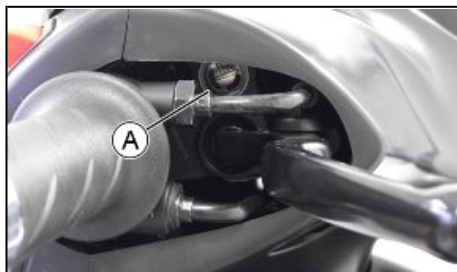

03_20

Checking the brake oil level (03_20)

The front and rear brake fluid reservoirs are both positioned on the handlebar. Proceed as follows:

- Rest the vehicle on its centre stand with the handlebars perfectly horizontal;
- Check the fluid level through the sight glass «A».

A certain lowering of the level is caused by wear on the pads. Should the level appear to be below the minimum mark, please contact a **PIAGGIO Authorised Service Centre or Dealer** in order to have the braking system thoroughly checked.



03_21

Braking system fluid top up (03_21, 03_22, 03_23, 03_24, 03_25, 03_26, 03_27, 03_28, 03_29)

For topping-up, proceed as follows:

- Remove the mirrors unscrewing them from their seats
- Unscrew the two screws «A» and remove the pressure covering.
- Unscrew the two screws «B» and, working on both sides of the vehicle, unscrew the screw «C».
- Using a flat-headed screwdriver, detach the fastener tab as shown in the figure, accessing the tab via the indicated slit.
- Insert the screwdriver between the two covers, as indicated in the figure, and detach the upper fastener tab. Move the rear handlebar cover aside.
- Unscrew the two screws «D» and remove the front handlebar cover releasing the front headlight connector
- Unscrew the two screws «E» and remove the cap «F» of the brake pump to top up to the optimum level.



03_22

WARNING

BRAKE CIRCUIT FLUID IS VERY CORROSIVE; DO NOT LET IT COME INTO CONTACT WITH PAINTED PARTS.

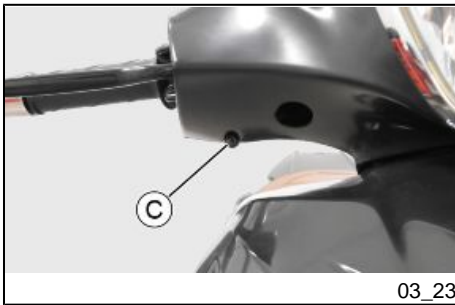

03_23

CAUTION

ONLY USE DOT 4-CLASSIFIED BRAKE FLUID.

WARNING

THE BRAKE FLUID IS HAZARDOUS: IN CASE OF ACCIDENTAL CONTACT, WASH OFF WITH WATER.

WARNING

THE BRAKING CIRCUIT LIQUID IS HYGROSCOPIC, AND ABSORBS THE HUMIDITY OF SURROUNDING AIR. IF THE HUMIDITY IN THE BRAKING FLUID EXCEEDS A CERTAIN VALUE, IT WILL LEAD TO INEFFICIENT BRAKING. NEVER USE BRAKING FLUID KEPT IN CONTAINERS THAT HAVE ALREADY BEEN OPENED, OR PARTIALLY USED.

Recommended products**Brake fluid**

Brake fluid

FMVSS DOT 4 Synthetic fluid



03_24

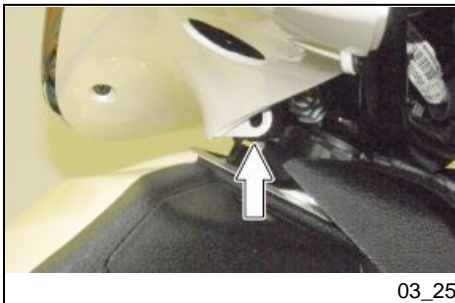

03_25



03_26



03_27

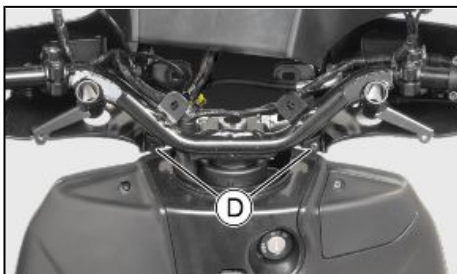

03_28

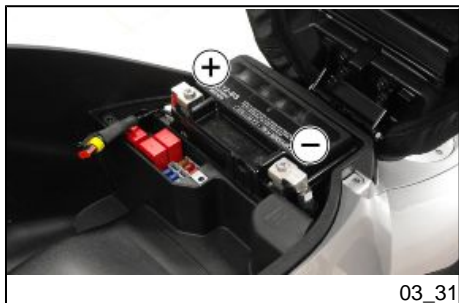
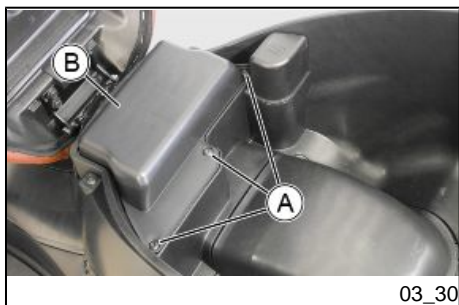
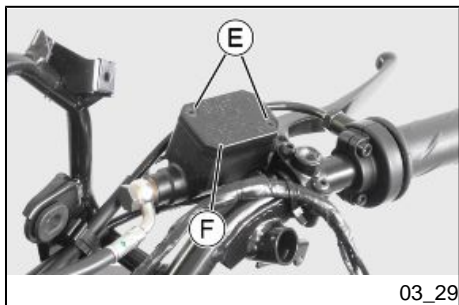

Battery (03_30, 03_31)

To access the battery, proceed as follows:

- Position the vehicle on centre stand
- Open the saddle, following the previously described procedure
- Unscrew the three screws «A» and remove the cover «B»

The battery is the electrical device that requires the most frequent attention and the most thorough maintenance.

The main points of maintenance to be observed are as follows:

WARNING



DO NOT DISCONNECT THE BATTERY CABLES WITH THE ENGINE RUNNING, THIS CAN CAUSE IRREPARABLE DAMAGE TO THE VEHICLE'S ELECTRONIC CONTROL UNIT.

WARNING

USED BATTERIES ARE HARMFUL FOR THE ENVIRONMENT. COLLECTION AND DISPOSAL SHOULD BE CARRIED OUT IN COMPLIANCE WITH REGULATIONS IN FORCE.

Characteristic**Battery**

SEALED 12V / 10Ah

Use of a new battery (03_32)

Ensure that the terminals are connected correctly and check the voltage.

CAUTION

DO NOT REVERSE THE POLARITY: RISK OF SHORT CIRCUIT AND DAMAGE TO THE ELECTRICAL SYSTEM.

Long periods of inactivity

Battery performance will decrease if the vehicle is not used for a long time. This is the result of the natural phenomenon of battery discharging, and may be due to residual absorption by vehicle components with constant power consumption. Poor battery performance may also be due to environmental conditions and the cleanness of the poles. In order to avoid difficult starts and/or irreversible damage to the battery, follow any of these steps:

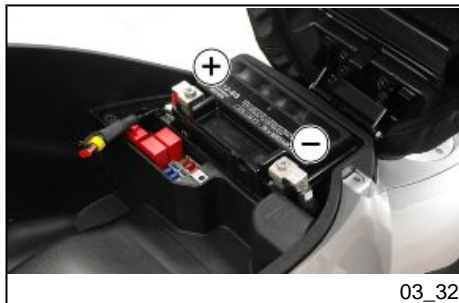

03_32

- **At least once a month** start the engine and run it slightly above idle speed for 10-15 minutes. This keeps all the engine components, as well as the battery, in good working order.

- Take your vehicle to a garage (as indicated in the «Vehicle not used for extended periods» section) to have the battery removed. Have the battery cleaned, charged fully and stored in a dry, ventilated place. Recharge **at least once every two months**.

CAUTION

THE BATTERY MUST BE RECHARGED WITH A CURRENT LOAD EQUAL TO 1/10 OF THE BATTERY RATED CAPACITY AND FOR A PERIOD NOT LONGER THAN 8 HOURS. TAKE THE VEHICLE TO AN AUTHORISED PIAGGIO SERVICE CENTRE FOR THIS OPERATION. WHEN REFITTING THE BATTERY MAKE SURE THE LEADS ARE CORRECTLY CONNECTED TO THE TERMINALS.

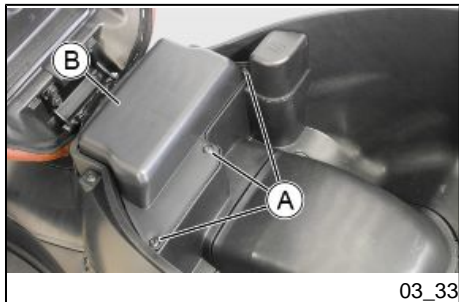

Fuses (03_33, 03_34, 03_35)

The electrical system is equipped with 6 protection fuses located below the saddle. Open the saddle as described above.

Unscrew the three screws «A» and remove the cover «B»

The chart shows the position and specifications of the fuses in the vehicle.

CAUTION



BEFORE REPLACING A BLOWN FUSE, FIND AND SOLVE THE FAILURE THAT CAUSED IT TO BLOW. NEVER TRY TO REPLACE THE FUSE WITH ANY OTHER MATERIAL (E.G., A PIECE OF ELECTRIC WIRE).



03_34

CAUTION

MODIFICATIONS OR REPAIRS TO THE ELECTRICAL SYSTEM, PERFORMED INCORRECTLY OR WITHOUT STRICT ATTENTION TO THE TECHNICAL SPECIFICATIONS OF THE SYSTEM CAN CAUSE MALFUNCTIONING AND RISK OF FIRE.

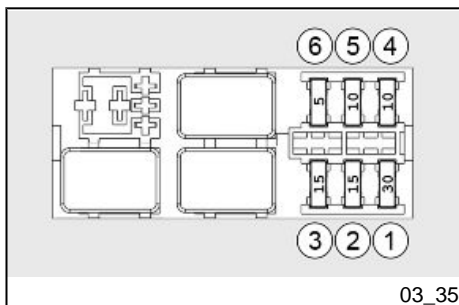

03_35

FUSES

Fuse No. 1

Capacity:30 A**Protected circuits:** general,
recharge battery**Live:** fuses No. 5 and 6

Fuse No. 2

Capacity: 15A

Protected circuits: battery-powered: antitheft device pre-installation, saddle opening control unit pre-installation, electric fan relay (contact)

Fuse No. 3

Capacity: 15A

Protected circuits: battery powered B.T. socket, helmet compartment light bulb, electronic control unit, injection load relay (contact); live saddle opener actuator

Fuse No. 4

Capacity: 10 A

Protected circuits: battery powered headlight relay (contact), instrument panel

Fuse No. 5

Capacity: 10 A

Protected circuits: live antitheft pre-installation, saddle opening control unit pre-installation, turn indicator control device, high-beam flash, instrument panel, daylight running light, horn, stop lights, starter enabling switch, licence plate light

Fuse No. 6

Capacity: 5A

Protected circuits: live headlight relay (coil), immobiliser aerial, electronic control unit, injection load relay (coil)

Lamps

BULBS

Low beam light bulb

Type: Halogen H7

Quantity: 1

Power: 12V - 55W

High beam light bulb

Type: Halogen H7

Quantity: 1

Power: 12V - 55W

Front tail light bulb

Type: LED

Quantity: -

Power: -

Front turn indicator light bulb

Type: Spherical BAU 15s

Quantity: 1 Right - 1 Left

Power: 12V - 10W

Stop light/rear daylight running
light bulb

Type: LED

Quantity: -

Power: -

Rear turn indicator light bulb

Type: Spherical BAU 15s

Quantity: 1 Right - 1 Left

Power: 12V - 10W

License plate light bulb

Type: All glass W5W

Quantity: 1

Power: 12V - 5W

Helmet compartment light bulb

Type: Cylindrical C5W

Quantity: 1

Power: 12V - 5W

Instrument panel lighting bulb

Type: LED

Quantity: 4

Power: -



03_36

Front light group (03_36, 03_37, 03_38, 03_39)

To remove the front headlight assembly, proceed as follows:

- Unscrew the two screws «A» and remove the pressure covering
- Unscrew the two upper screws «E» fastening the headlight assembly
- Working on both sides of the vehicle, unscrew the lower fixing screws «C» and remove the headlight. Remove the rubber protection.

This gives access to the bulbs.

To replace the low-beam light act on the lamp holder«D». To replace the high-beam light act on the lamp holder«E» unhooking the relevant pin.

To reassemble, repeat the operation but in reverse order.

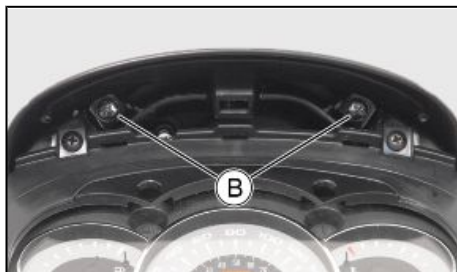

03_37

WARNING

HIGH- AND LOW-BEAM BULBS ARE HALOGEN TYPE: DO NOT TOUCH THEM WITH YOUR FINGERS TO AVOID DAMAGING THEIR FUNCTION.

CAUTION

DO NOT LEAN OR CARRY OBJECTS OR CLOTHING OVER THE FRONT HEADLIGHTS. IT CAN CAUSE OVERHEATING AND CONSEQUENTIAL FUSING OR DAMAGE TO THE GLASS.

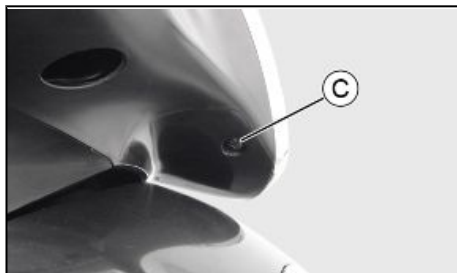

03_38

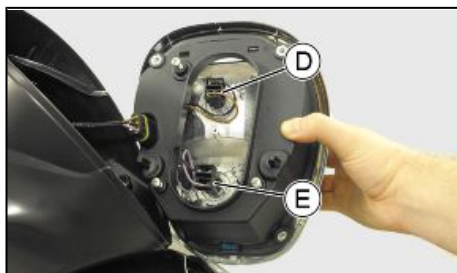

03_39

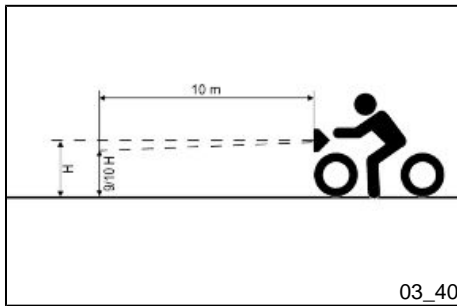

03_40



03_41

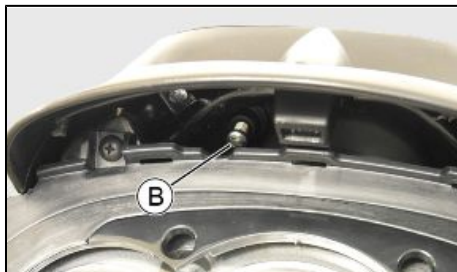

03_42

Headlight adjustment (03_40, 03_41, 03_42)

Proceed as follows:

- Position the vehicle in running order and with the tyres inflated to the prescribed pressure, onto a flat surface, 10 m away from a half-lit white screen; ensure that the longitudinal axis of the vehicle is perpendicular to the screen;
- Turn on the headlight and check that the borderline of the projected light beam on the screen is not higher than 9/10 or lower than 7/10 of the distance from the ground to the centre of the vehicle headlamp;
- Otherwise, adjust the headlight. Unscrew the two screws «A» and remove the pressure covering. Screw in the screw «B» to lower the light beam, unscrew the screw «B» to raise the light beam.

N.B.

THE ABOVE PROCEDURE COMPLIES WITH THE EUROPEAN STANDARDS REGARDING MAXIMUM AND MINIMUM HEIGHT OF LIGHT BEAMS. REFER TO THE STATUTORY REGULATIONS IN FORCE IN EVERY COUNTRY WHERE THE VEHICLE IS USED.

Front direction indicators (03_43, 03_44, 03_45)

To replace the indicator bulbs proceed as follows:

- Open the front case
- Remove the rubber protection
- Remove the lamp holder, rotating it towards the inside of the vehicle
- Lightly press the lamp and turn it anticlockwise and remove it.



03_43



03_44



03_45

WARNING



THE DAYLIGHT RUNNING LIGHTS PRESENT IN THE SAME GROUP ARE «LED» TYPES. IN CASE OF MALFUNCTIONING, AS THE REMOVAL IS PARTICULARLY DIFFICULT, WE ADVISE ADDRESSING AN Authorised PIAGGIO Service Centre FOR THE REPLACEMENT.



03_46

Rear optical unit (03_46, 03_47, 03_48)

To replace the indicator bulbs proceed as follows:

- Open the saddle
- Remove the rubber protection
- Remove the lamp holder turning it towards the base
- Lightly press the lamp and turn it anticlockwise and remove it.



03_47

WARNING



THE DAYLIGHT RUNNING LIGHTS PRESENT IN THE SAME GROUP ARE «LED» TYPES. IN CASE OF MALFUNCTIONING, AS THE REMOVAL IS PARTICULARLY DIFFICULT, WE ADVISE ADDRESSING AN Authorised PIAGGIO Service Centre FOR THE REPLACEMENT.



03_48



03_49

Number plate light (03_49)

Unscrew the indicated screw and then take out the lamp holder.

CAUTION



DO NOT PULL THE ELECTRICAL WIRING TO EXTRACT THE BULB HOLDER.



03_50

Helmet compartment lighting bulb (03_50)

Open the helmet compartment, take out the snap-on transparent glass and replace the bulb.

Rear-view mirrors

Adjust the mirrors by applying slight pressure to the side of the mirror to move it to the desired position.



03_51

Front and rear disc brake (03_51)

The brake disc and pad wear is automatically compensated, therefore it has no effect on the functioning of the front and rear brakes. For this reason it is not necessary to adjust the brakes. An excessively elastic brake lever stroke may indicate the presence of air in the braking circuit or a failure in the braking system. In this case, mainly due to the importance of brakes to guarantee safe riding conditions, the vehicle should be taken to an **Authorised Service Centre or Dealer**.

CAUTION



BRAKING SHOULD BEGIN AFTER ABOUT 1/3 OF THE BRAKE LEVER STROKE.

CAUTION



HAVE THE BRAKE PADS CHECKED BY THE DEALER ACCORDING TO THE CHECKS SPECIFIED IN THE SCHEDULED MAINTENANCE TABLE. HOWEVER, IN THE EVENT OF NOISES COMING FROM THE FRONT AND/OR REAR BRAKING SYSTEM DURING OPERATION, IT IS ADVISABLE TO HAVE THE BRAKING SYSTEM CHECKED BY AN AUTHORISED SERVICE CENTRE OR DEALER. AFTER REPLACING THE BRAKE PADS, DO NOT USE THE SCOOTER UNTIL YOU HAVE OPERATED THE BRAKE LEVER SEVERAL TIMES IN ORDER TO ALLOW THE PLUNGERS TO SETTLE AND THE LEVER STROKE TO BE SET TO THE CORRECT POSITION.

CAUTION



THE PRESENCE OF SAND, MUD, SNOW MIXED WITH SALT, ETC. ON THE ROAD, CAN DRASTICALLY REDUCE THE LIFE OF THE BRAKE PADS. IN ORDER TO AVOID THIS, WE RECOMMEND WASHING THE VEHICLE FREQUENTLY WHEN RIDING IN THESE ROAD CONDITIONS.

Puncture

The vehicle is equipped with Tubeless tyres (without inner tube). In the event of a puncture, Tubeless tyres - unlike tyres with inner tubes - go flat very slowly, resulting in a greater steering safety. In the event of a puncture, an emergency repair can be carried out using an "inflate and repair" spray can. For a final repair, take your vehicle to an **Authorised Service Centre or Dealer**. The replacement of a tyre involves removing the wheel in question. Take your vehicle to an **Authorised Service Centre or Dealer** for these operations.

CAUTION



TO USE THE "INFLATE AND REPAIR" SPRAY CAN PROPERLY, FOLLOW THE INSTRUCTIONS ON THE PACKAGING.

WARNING



THE WHEELS FITTED WITH TYRES SHOULD ALWAYS BE BALANCED. RIDING THE VEHICLE WITH VERY LOW TYRE PRESSURE OR WITH INCORRECTLY BALANCED TYRES CAN LEAD TO DANGEROUS STEERING VIBRATIONS.

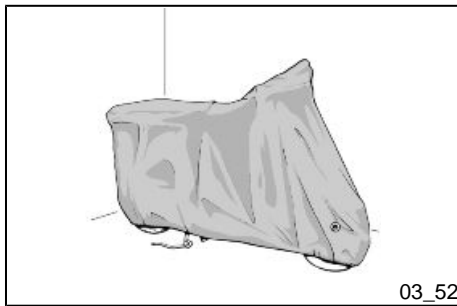

03_52

Periods of inactivity (03_52)

We recommend carrying out the following operations:

1. Clean the vehicle thoroughly and then cover it with a canvas;
2. With the engine off and the piston in the bottom dead centre position, remove the spark plug, and pour into its hole 1 to 2 cc of the recommended oil. Operate the starter button 1-2 times for roughly 1 second to turn the engine over slowly, then insert the spark plug again;
3. Ensure that the **fuel tank is at least half full (in order to ensure the total immersion of the fuel pump)**; spread antirust grease on the unpainted metal parts; keep the wheels lifted above the ground by resting the chassis on two wooden wedges;
4. As regards the battery, follow the instructions in the «Battery» section.

Recommended products

AGIP CITY HI TEC 4T

Oil to lubricate flexible transmissions (throttle control)

Oil for 4-stroke engines

Cleaning the vehicle

Use a low pressure jet of water to soften the caked dirt and mud deposited on the painted surfaces. Once softened, sponge off mud and dirt using a car body sponge soaked in a car body shampoo and water solution (2-4% of car shampoo in water). Then rinse with abundant water, and dry with a shammy cloth. For the engine exterior, use petrol, a brush and clean cloths. Petrol can damage paintwork. Remember that any polishing with silicone wax must always be preceded by washing.

CAUTION

DETERGENTS CAN POLLUTE WATER. THE VEHICLE MUST BE WASHED AT A WASH STATION EQUIPPED WITH A SPECIAL WATER PURIFICATION SYSTEM.

CAUTION

DO NOT USE A HIGH-PRESSURE WATER JET MACHINE TO CLEAN THE ENGINE AND/OR VEHICLE; HOWEVER, IF NO OTHER MEANS ARE AVAILABLE, IT IS THEN NECESSARY TO:

- **ONLY USE A FANLIKE SPRAY JET.**
- **DO NOT PLACE THE NOZZLE CLOSER THAN 60 CM.**
- **DO NOT USE WATER AT TEMPERATURES OVER 40°C.**
- **DO NOT USE HIGH-PRESSURE WATER JETS.**
- **DO NOT STEAM WASH.**
- **DO NOT AIM THE JET AT: THE ENGINE, THE WIRING, THE COOLING SLITS ON THE TRANSMISSION OR SCROLL COVERS.**

CAUTION

NEVER WASH THE SCOOTER IN DIRECT SUNLIGHT, ESPECIALLY IN SUMMER WHEN THE BODYWORK IS STILL HOT AS THE SHAMPOO COULD DAMAGE THE PAINTWORK IF IT DRIES BEFORE BEING RINSED OFF. NEVER USE CLOTHS SOAKED IN ALCOHOL, PETROL, DIESEL OIL OR KEROSENE FOR CLEANING THE PAINTED OR PLASTIC SURFACES, IN ORDER NOT TO DAMAGE THE LUSTRE FINISH OR ALTER THEIR MECHANICAL PROPERTIES. USING SILICONE-BASED WAX CAN DAMAGE THE PAINTED SURFACES, DEPENDING ON THE VEHICLE COLOUR (SATIN COLOURS). FOR FURTHER

INFORMATION ON THIS MATTER, CONTACT AN AUTHORISED SERVICE CENTRE.

WARNING



CLEAN YOUR SCOOTER FREQUENTLY SO AS TO AVOID POSSIBLE DIRT OR MUD DEPOSITS THAT COULD CAUSE MALFUNCTIONING IN THE THROTTLE GRIP TRANSMISSION AND/OR OTHER COMPONENTS.

Troubleshooting

STARTING FAILURE

Emergency switch in «OFF»	Set the switch back to «ON»
Fuse blown	Replace the blown fuse and have the vehicle checked by an Authorised Service Centre .

STARTING DIFFICULTIES (SEE «START-UP PROBLEMS» SECTION)

Lack of fuel in tank.	Refuelling
Injection system fault	Contact an Authorised Service Centre

Fuel pump fault	Contact an Authorised Service Centre
Flat battery	Recharge the battery.

**** IMPORTANT: DO NOT USE THE SCOOTER TO THE COMPLETE EXHAUSTION OF FUEL; SHOULD THIS OCCUR, DO NOT ATTEMPT TO START THE ENGINE. TURN THE IGNITION KEY TO «OFF» AND TOP-UP THE FUEL TANK AS SOON AS POSSIBLE. FAILURE TO FOLLOW THESE GUIDELINES COULD DAMAGE THE FUEL PUMP AND/OR THE CATALYTIC CONVERTER.***

IGNITION PROBLEMS

Faulty spark plug	Contact an Authorised Service Centre.
Faulty ignition / injection control unit. Due to the presence of high voltage, this check should only be carried out by an expert.	Contact an Authorised Service Centre

LACK OF COMPRESSION

Loose spark plug.	Screw in the spark plug tightly
Cylinder head loose, piston gas rings worn.	Contact an Authorised Service Centre.
Valve stuck	Contact an Authorised Service Centre.

HIGH CONSUMPTION AND LOW PERFORMANCE

Clogged or dirty air filter

Try to blow out with compressed air, otherwise replace the filter

INSUFFICIENT BRAKING

Greasy disc. Worn pads. Faulty braking system. Presence of air in the front and rear brake circuit.

Contact an **Authorised Service Centre**.

INEFFICIENT SUSPENSION

Shock absorber fault, oil leak, end buffers damaged; shock absorber preloading incorrectly set

Contact an **Authorised Service Centre**.

AUTOMATIC TRANSMISSION PROBLEMS

CVT rollers and/or drive belt damaged

Contact an **Authorised Service Centre**.

Beverly 300ie



PIAGGIO®



Chap. 04
Technical data

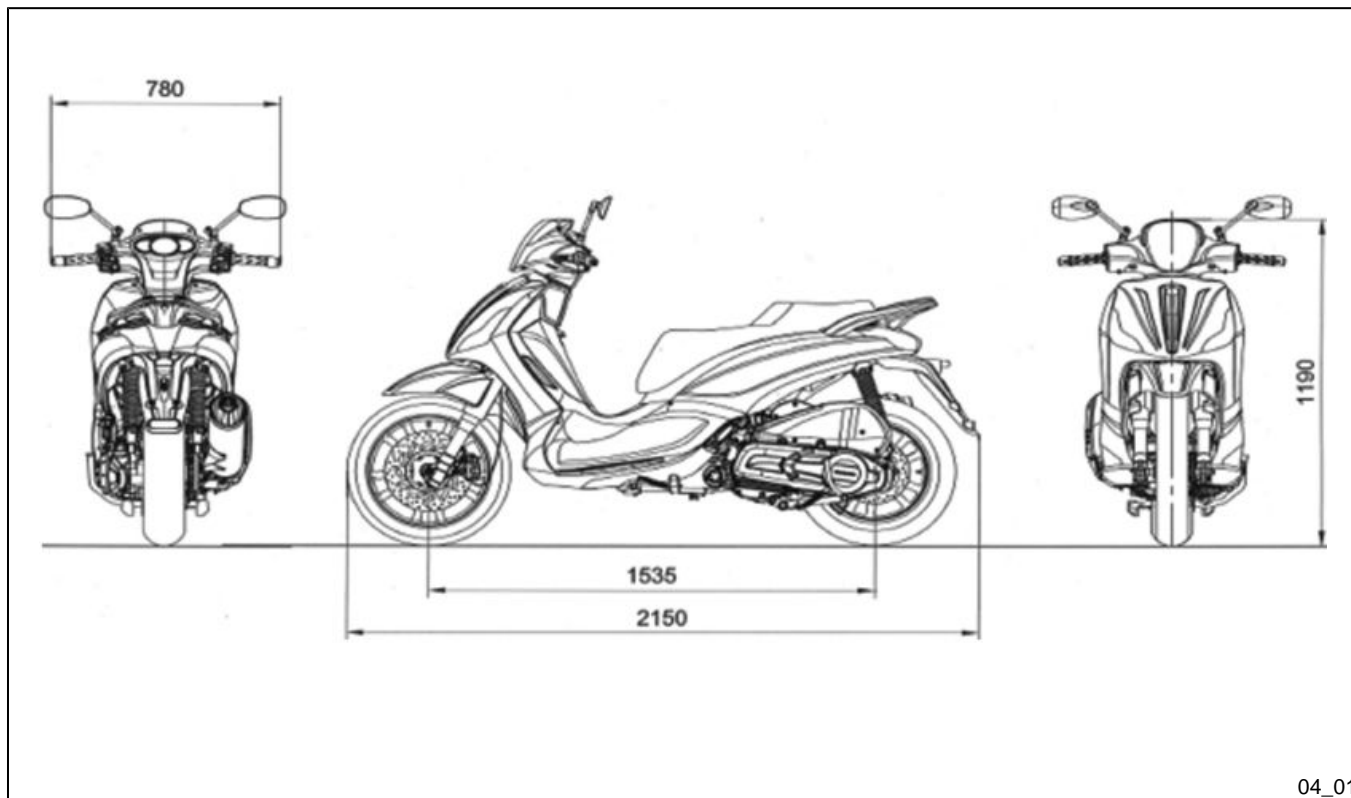

ENGINE TECHNICAL DATA

Type	Single-cylinder, 4-stroke
Engine capacity	278 cm ³
Bore x stroke	75 X 63 mm
Compression ratio	11 ± 0.5: 1
Engine idle speed	1,700 ± 100 rpm
Timing system	Four valves, single overhead camshaft, chain-driven.
Valve clearance	Intake: 0.10 mm Exhaust: 0.15 mm
Max. power	16.3 kW at 7,250 rpm
MAX. torque	23 Nm at 5,750 rpm
Transmission	Automatic expandable pulley variator with torque server, V belt, automatic clutch.
Final reduction gear	Gear reduction unit in oil bath.
Lubrication	Engine lubrication with trochoidal pump (inside the crankcase), oil filter and pressure adjustment by-pass.
Cooling	Forced coolant circulation system.
Starter	Electric
Ignition	Electronic, inductive, high efficiency ignition, integrated with the injection system, with variable advance and separate HV coil.

Ignition advance	Three-dimensional map managed by control unit
Fuel system	32 MIU1.E9 Electronic injection, with Ø 32-mm throttle body and electric fuel pump.
Spark plug	NGK CR8EKB
Fuel	Unleaded petrol (95 RON)
Silencer	Absorption-type exhaust muffler with catalytic converter and lambda probe.
Emission regulations	EURO 3

VEHICLE TECHNICAL DATA

Chassis	Tubular and steel sheets.
Front suspension	Hydraulic telescopic fork with Ø 35-mm stem
Rear suspension	Two double-acting shock absorbers, adjustable to four positions at preloading.
Front brake	Ø 300-mm disc brake with hydraulic control activated by handlebar right-side lever.
Rear brake	Ø 240-mm disc brake with hydraulic control activated by handlebar left-side lever.
Wheel rim type	Light alloy wheel rims.

Front wheel rim	3.00" x 16"
Rear wheel rim	3.50" x 14"
Front tyre	110/70 - Tubeless 16" 52S or 52P
Rear tyre	140/70 - Tubeless 14" 68P or 68S
Front tyre pressure (with passenger)	2.2 bar (2.2 bar)
Rear tyre pressure (with passenger)	2.4 bar (2.6 bar)
Kerb weight	171 kg \pm 8 kg
Maximum weight allowed	365 kg
Battery	SEALED 12V / 10Ah

CAPACITY

Engine oil	1.3 l
Transmission oil	250 cm ³
Cooling system fluid	1.75 l
Fuel tank	13 l \pm 1



Toolkit (04_02)

The tools are stored under the saddle.

The toolkit includes:

- One box-spanner
- One twin screwdriver
- One special key for adjusting rear shock absorbers
- An extractor for fuses
- One lever for box-spanner
- One double torx wrench

Beverly 300ie



PIAGGIO®



**Chap. 05
Spare parts and
accessories**



Warnings (05_01)

WARNING



TO PREVENT ACCIDENTS AND TO GUARANTEE PROPER STABILITY, PERFORMANCE AND SAFETY, RIDE THE VEHICLE VERY CAREFULLY WHEN IT IS FITTED WITH ACCESSORIES OR WITH UNUSUAL LOADS.

WARNING



IT IS ALSO RECOMMENDED THAT ORIGINAL PIAGGIO SPARE PARTS BE USED, AS THESE ARE THE ONLY ONES OFFERING YOU THE SAME QUALITY GUARANTEE AS THOSE INITIALLY FITTED ON THE SCOOTER. THE USE OF NON-ORIGINAL SPARE PARTS RENDERS THE WARRANTY VOID.

WARNING



PIAGGIO MARKETS ITS OWN LINE OF ACCESSORIES THAT ARE RECOGNISED AND GUARANTEED FOR USE. IT IS THEREFORE ESSENTIAL TO CONTACT AN AUTHORISED DEALER OR SERVICE CENTRE IN ORDER TO CHOOSE AND FIT ACCESSORIES CORRECTLY. THE USE OF NON-ORIGINAL ACCESSORIES MAY AFFECT THE STABILITY AND OPERATION OF YOUR VEHICLE AND REDUCE SAFETY LEVELS WITH POTENTIAL RISKS FOR THE RIDER.

WARNING

NEVER RIDE THE SCOOTER EQUIPPED WITH ACCESSORIES (TOP BOX AND/OR WINDSHIELD) AT A SPEED HIGHER THAN 100 km/h.

THE SCOOTER CAN BE RIDDEN AT A HIGHER SPEED WITHOUT THE ACCESSORIES MENTIONED BEFORE WITHIN THE LIMITS ESTABLISHED BY LAW.

IF THERE ARE ANY NON-PIAGGIO ACCESSORIES INSTALLED, OR AN ABNORMAL LOAD, OR IF THE SCOOTER IS NOT IN A GENERALLY GOOD CONDITION, OR WHENEVER WEATHER CONDITIONS DEMAND IT, SPEED SHOULD BE FURTHER REDUCED.

WARNING

BE EXTREMELY CAREFUL WHEN INSTALLING AND REMOVING THE MECHANICAL ANTITHEFT DEVICE ON THE VEHICLE (U-SHAPED PADLOCK, DISC BLOCK, ETC.).

MAINLY NEAR THE BRAKE PIPES, TRANSMISSIONS AND/OR ELECTRIC CABLES, AN INCORRECT INSTALLATION OR REMOVAL OF THE ANTITHEFT DEVICE AS WELL AS LEAVING IT ON BEFORE STARTING THE VEHICLE CAN SERIOUSLY DAMAGE ITS COMPONENTS, COMPROMISE THE CORRECT FUNCTIONING OF THE VEHICLE AND USERS' SAFETY.

Beverly 300ie



PIAGGIO®



**Chap. 06
Scheduled
maintenance**



06_01

Scheduled servicing table (06_01)

Adequate maintenance is fundamental to ensure long-lasting, optimum operation and performance of your vehicle.

To this end, a series of checks and maintenance operations (at the owner's expense) have been suggested, which are included in the summary table on the following page. Any minor faults should be reported without delay to an **Authorised Service Centre or Dealer** without waiting until the next scheduled service to solve it.

All scheduled maintenance services must be carried out at the specified intervals, even if the stated mileage has not yet been reached. Punctual scooter servicing is essential to ensure your warranty remains valid. For any further information concerning Warranty procedures and 'Scheduled Maintenance', please refer to the 'Warranty Booklet'.

MAINTENANCE TABLE

Km x 1,000	1	5	10	15	20	25	30	35	40	45	50	55	60	65	70	75	80
Driven pulley roller casing			L		L		L		L		L		L		L		L
Safety fasteners	I		I				I				I				I		
Ignition spark plug			R		R		R		R		R		R		R		R
Centre stand bracket		L	L	L	L	L	L	L	L	L	L	L	L	L	L	L	L
Drive belt				R			R			R			R			R	
Throttle control	A		A		A		A		A		A		A		A		A
Air filter/CVT filter **			C		C		C		C		C		C		C		C
Oil filter	R		R		R		R		R		R		R		R		R
Valve clearance					A				A				A				A
Electrical system and battery	I		I		I		I		I		I		I		I		I

Km x 1,000	1	5	10	15	20	25	30	35	40	45	50	55	60	65	70	75	80
Coolant level *	I		I		I		I		I		I		I		I		I
Brake fluid *	I		I		I		I		I		I		I		I		I
Engine oil	R	I	R	I	R	I	R	I	R	I	R	I	R	I	R	I	R
Hub oil	R		I		R		I		R		I		R		I		R
Brake pads	I	I	I	I	I	I	I	I	I	I	I	I	I	I	I	I	I
Sliding shoes / CVT rollers			R		R		R		R		R		R		R		R
Tyre pressure and wear	I		I		I		I		I		I		I		I		I
Vehicle road test	I		I		I		I		I		I		I		I		I
Suspension	I		I		I		I		I		I		I		I		I
Steering	A		I		I		I		I		I		I		I		I

I: INSPECT AND CLEAN, ADJUST, LUBRICATE OR REPLACE, IF NECESSARY C: CLEAN, R: REPLACE, A: ADJUST, L: LUBRICATE

** Replace every 2 years*

*** Clean frequently in cases of intensive use on gravel roads*

RECOMMENDED PRODUCTS TABLE

Product	Description	Specifications
AGIP ROTRA 80W-90	Rear hub oil	SAE 80W/90 Oil that exceeds the requirements of API GL3 specifications
AGIP CITY HI TEC 4T	Oil to lubricate flexible transmissions (throttle control)	Oil for 4-stroke engines

Product	Description	Specifications
AGIP FILTER OIL	Oil for air filter sponge	Mineral oil with specific additives for increased adhesiveness
AGIP GP 330	Grease for brake lever, gas	White calcium complex soap-based spray grease with NLGI 2; ISO-L-XBCIB2
AGIP CITY HI TEC 4T	Engine oil	SAE 5W-40, API SL, ACEA A3, JASO MA Synthetic oil
AGIP BRAKE 4	Brake fluid	FMVSS DOT 4 Synthetic fluid
AGIP PERMANENT SPECIAL	coolant	Monoethylene glycol-based antifreeze fluid, CUNA NC 956-16

**UNIT OF MEASURE - CONVERSION - ENGLISH SYSTEM
TO INTERNATIONAL SYSTEM (IS).**

1 Inch (in)	25.4 Millimetres (mm)
1 Foot (ft)	0.305 Meter (m)
1 Mile (mi)	1.609 Kilometre (km)
1 US Gallon (USgal)	3.785 Litre (l)
1 Pound (lb)	0.454 Kilogram (kg)
1 Cubic inch (in ³)	16.4 Cubic centimetres (cm ³)
1 Foot pound (ft lb)	1,356 Newton meter (Nm)
1 Mile per hour (mi/h)	1.602 Kilometres per hour (km/h)
1 Pound per square inch (PSI)	0.069 (bar)
1 Fahrenheit (°F)	32+(9/5) Celsius (°C)

TABLE OF CONTENTS

A

Air filter: 48

B

Battery: 54, 55

Brake: 51, 66

C

Checks: 26

D

Disc brake: 66

Display: 11

E

Engine oil: 40–42

Engine stop: 16

F

Fuel: 20

Fuses: 56

H

Headlight: 62

Horn: 14

Hub oil: 43

I

Identification: 22

Immobilizer: 16, 19

Instrument panel: 10

K

Key switch: 12

Keys: 16

L

Light switch: 15

M

Maintenance: 39, 83

Mirrors: 65

P

Puncture: 67

R

Refuelling: 26

S

Saddle: 21

Scheduled maintenance: 83

Shock absorbers: 29

Spark plug: 47

Stand: 33

Start-up: 15

Switch: 12, 14, 15

T

Tank: 20

Technical Data: 73

Toolkit: 78

Top box: 23

Transmission: 34

Tyre pressure: 28

Tyres: 45

V

Vehicle: 7, 68



The descriptions and illustrations given in this publication are not binding. While the basic specifications as described and illustrated in this manual remain unchanged, PIAGGIO-GILERA reserves the right, at any time and without being required to update this publication beforehand, to make any changes to components, parts or accessories, which it considers necessary to improve the product or which are required for manufacturing or construction reasons.

Not all versions/models shown in this publication are available in all countries. The availability of each model should be checked at the official Piaggio sales network.

"© Copyright 2008 - PIAGGIO & C. S.p.A. Pontedera. All rights reserved. Reproduction of this publication in whole or in part is prohibited."

PIAGGIO & C. S.p.A. - After-Sales

V.le Rinaldo Piaggio, 23 - 56025 PONTEDERA (Pi)