

---

# **MANUALE STAZIONE DI SERVIZIO**

---

**665357(IT) -665358(EN) -665359(FR) -665360(DE)  
-665361(ES) -665362(EL) -665363(PT) -665364(NL)**

---



**Beverly 300 i.e.**

---



# MANUALE STAZIONE DI SERVIZIO

## Beverly 300 i.e.

The descriptions and illustrations given in this publication are not binding. While the basic specifications as described and illustrated in this manual remain unchanged, PIAGGIO-GILERA reserves the right, at any time and without being required to update this publication beforehand, to make any changes to components, parts or accessories, which it considers necessary to improve the product or which are required for manufacturing or construction reasons.

Not all versions/models shown in this publication are available in all countries. The availability of single versions should be checked at the official Piaggio sales network.

"© Copyright 2008 - PIAGGIO & C. S.p.A. Pontedera. All rights reserved. Reproduction of this publication in whole or in part is prohibited."

PIAGGIO & C. S.p.A. - After-Sales

V.le Rinaldo Piaggio, 23 - 56025 PONTEDERA (Pi)

---

---

# MANUALE STAZIONE DI SERVIZIO

## Beverly 300 i.e.

Questo manuale per stazioni di servizio è stato realizzato da Piaggio & C. Spa per essere utilizzato dalle officine dei concessionari e sub-agenzie Piaggio-Gilera. Si presuppone che chi utilizza questa pubblicazione per la manutenzione e la riparazione dei veicoli Piaggio, abbia una conoscenza base dei principi della meccanica e dei procedimenti inerenti la tecnica della riparazione dei veicoli. Le variazioni importanti nelle caratteristiche dei veicoli o nelle specifiche operazioni di riparazione verranno comunicate attraverso aggiornamenti di questo manuale. Non si può comunque realizzare un lavoro completamente soddisfacente se non si dispone degli impianti e delle attrezzature necessarie, ed è per questo che vi invitiamo a consultare le pagine di questo manuale riguardanti l'attrezzatura specifica e il catalogo degli attrezzi specifici.

**N.B.** Provides key information to make the procedure easier to understand and carry out.

**CAUTION** Refers to specific procedures to carry out for preventing damages to the vehicle.

**WARNING** Refers to specific procedures to carry out to prevent injuries to the repairer.



**Personal safety** Failure to completely observe these instructions will result in serious risk of personal injury.



**Safeguarding the environment** Sections marked with this symbol indicate the correct use of the vehicle to prevent damaging the environment.



**Vehicle intactness** The incomplete or non-observance of these regulations leads to the risk of serious damage to the vehicle and sometimes even the invalidity of the guarantee.

---



## INDEX OF TOPICS

CHARACTERISTICS

CHAR

TOOLING

TOOL

MAINTENANCE

MAIN

TROUBLESHOOTING

TROUBL

ELECTRICAL SYSTEM

ELE SYS

ENGINE FROM VEHICLE

ENG VE

ENGINE

ENG

INJECTION

INJEC

SUSPENSIONS

SUSP

BRAKING SYSTEM

BRAK SYS

COOLING SYSTEM

COOL SYS

CHASSIS

CHAS

PRE-DELIVERY

PRE DE

TIME

TIME

## INDEX OF TOPICS

CHARACTERISTICS

CHAR

This section describes the general specifications of the vehicle.

---

## **Rules**

This section describes general safety rules for any maintenance operations performed on the vehicle.

---

### **Safety rules**

- If work can only be done on the vehicle with the engine running, make sure that the premises are well ventilated, using special extractors if necessary; never let the engine run in an enclosed area. Exhaust fumes are toxic.
  - The battery electrolyte contains sulphuric acid. Protect your eyes, clothes and skin. Sulphuric acid is highly corrosive; in the event of contact with your eyes or skin, rinse thoroughly with abundant water and seek immediate medical attention.
  - The battery produces hydrogen, a gas that can be highly explosive. Do not smoke and avoid sparks or flames near the battery, especially when charging it.
  - Fuel is highly flammable and it can be explosive given some conditions. Do not smoke in the working area, and avoid naked flames or sparks.
  - Clean the brake pads in a well-ventilated area, directing the jet of compressed air in such a way that you do not breathe in the dust produced by the wear of the friction material. Even though the latter contains no asbestos, inhaling dust is harmful.
- 

### **Maintenance rules**

- Use original PIAGGIO spare parts and lubricants recommended by the Manufacturer. Non-original or non-conforming spares may damage the vehicle.
  - Use only the appropriate tools designed for this vehicle.
  - Always use new gaskets, sealing rings and split pins upon refitting.
  - After removal, clean the components using non-flammable or low flash-point solvents. Lubricate all the work surfaces, except tapered couplings, before refitting these parts.
  - After refitting, make sure that all the components have been installed correctly and work properly.
  - For removal, overhaul and refit operations use only tools with metric measures. Metric bolts, nuts and screws are not interchangeable with coupling members with English measurement. Using unsuitable coupling members and tools may damage the vehicle.
  - When carrying out maintenance operations on the vehicle that involve the electrical system, make sure the electrical connections have been made properly, particularly the ground and battery connections.
-

## Vehicle identification

### Chassis number

To read the chassis number, remove the port **A** in the front case.



### Engine number

The engine number «**B**» is stamped near the rear left shock absorber lower support.

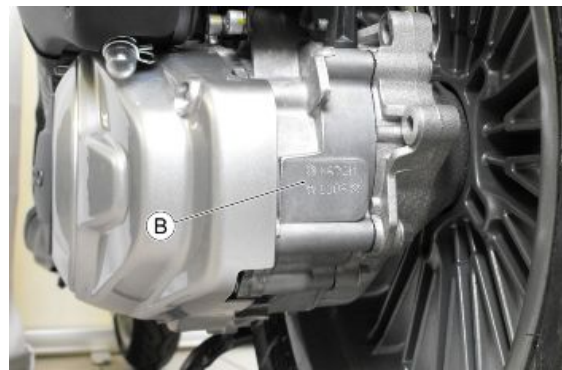

## Dimensions and mass

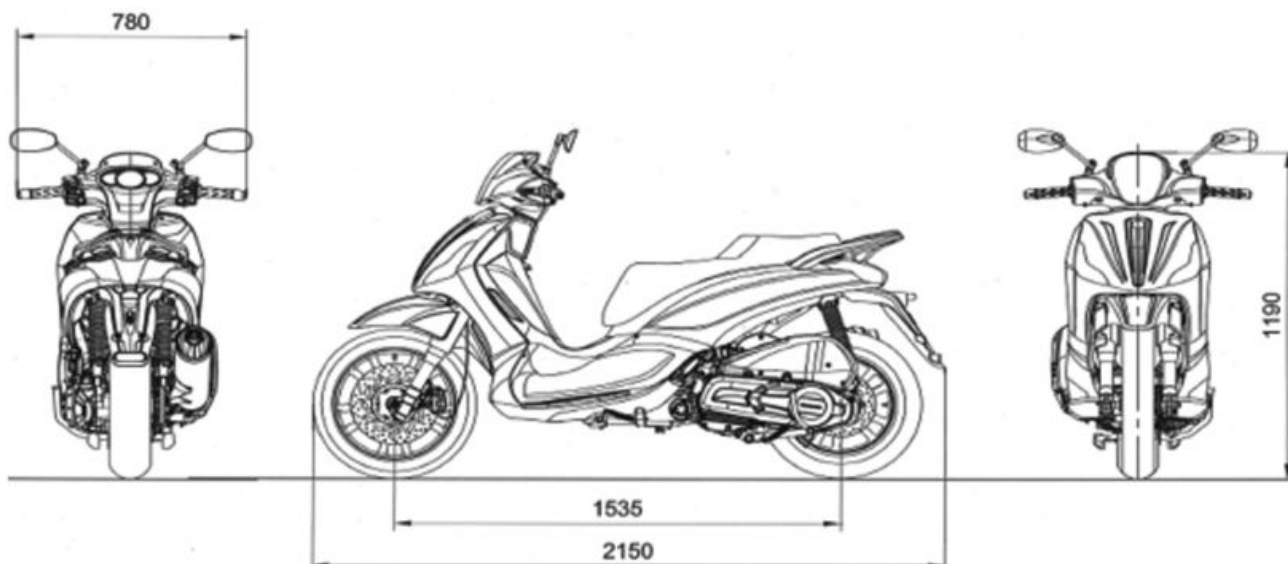



**WEIGHTS AND DIMENSIONS**

Specification	Desc./Quantity
Length	2150 mm
Width	780 mm
Wheelbase	1535 mm
Height	1190 mm
Kerb weight	171 kg ± 8 kg
Maximum weight allowed	365 kg

**Engine****ENGINE**

Specification	Desc./Quantity
Type	Single-cylinder, 4-stroke
Engine capacity	278 cm <sup>3</sup>
Bore x stroke	75 X 63 mm
Compression ratio	11 ± 0.5: 1
Engine idle speed	1,700 ± 100 rpm
Timing system	Four valves, single overhead camshaft, chain-driven.
Valve clearance	Intake: 0.10 mm Exhaust: 0.15 mm
Max. power	16.3 kW at 7,250 rpm
MAX. torque	23 Nm at 5,750 rpm
Lubrication	Engine lubrication with trochoidal pump (inside the crankcase), oil filter and pressure adjustment by-pass.
Fuel system	32 MIU1.E9 Electronic injection, with Ø 32-mm throttle body and electric fuel pump.
Cooling	Forced coolant circulation system.
Fuel	Unleaded petrol (95 RON)
Silencer	Absorption-type exhaust muffler with catalytic converter and lambda probe.
Emissions compliance	EURO 3

**Transmission****TRANSMISSION**

Specification	Desc./Quantity
Transmission	Automatic expandable pulley variator with torque server, V-belt, self-ventilating dry automatic centrifugal clutch and transmission housing with forced-circulation air cooling.
Final reduction gear	Gear reduction unit in oil bath.

**Capacities****CAPACITY**

Specification	Desc./Quantity
Engine oil	1.3 l
Transmission oil	250 cm <sup>3</sup>
Cooling system fluid	1.75 l
Fuel tank	13 l ± 1

## Electrical system

### ELECTRICAL SYSTEM

Specification	Desc./Quantity
Starter	starter
Ignition	Electronic, inductive, high efficiency ignition, integrated with the injection system, with variable advance and separate HV coil.
Ignition advance	Three-dimensional map managed by control unit
Spark plug	NGK CR8EKB
Battery	SEALED 12V/10Ah
Generator	alternating current

## Frame and suspensions

### WHEELS AND TYRES

Specification	Desc./Quantity
Wheel rim type	Light alloy wheel rims.
Front wheel rim	3.00" x 16"
Rear wheel rim	3.50" x 14"
Front tyre	110/70 - Tubeless 16" 52S or 52P
Rear tyre	140/70 - Tubeless 14" 68P or 68S
Front tyre pressure (with passenger)	2.2 bar (2.2 bar)
Rear tyre pressure (with passenger)	2.4 bar (2.6 bar)

## Brakes

### BRAKES

Specification	Desc./Quantity
Front brake	Ø 300-mm disc brake with hydraulic control activated by handlebar right-side lever.
Rear brake	Ø 240-mm disc brake with hydraulic control activated by handlebar left-side lever.

## Wheels and tyres

### WHEELS AND TYRES

Specification	Desc./Quantity
Wheel rim type	Light alloy wheel rims.
Front wheel rim	3.00" x 16"
Rear wheel rim	3.50" x 14"
Front tyre	110/70 - Tubeless 16" 52S or 52P
Rear tyre	140/70 - Tubeless 14" 68P or 68S
Front tyre pressure (with passenger)	2.2 bar (2.2 bar)
Rear tyre pressure (with passenger)	2.4 bar (2.6 bar)

N.B.

**CHECK AND ADJUST TYRE PRESSURE WITH TYRES AT AMBIENT TEMPERATURE. REGULATE PRESSURE ACCORDING TO THE WEIGHT OF BOTH RIDER AND ACCESSORIES**

## Tightening Torques

### STEERING

Name	Torque in Nm
Handlebar fixing screw (*)	45 to 50

Name	Torque in Nm
Fixing screws for the handlebar control unit U-bolts	7 to 10
Steering tube upper ring nut	40 ÷ 45
Steering tube lower ring nut	14 ÷ 17

### **CHASSIS**

Name	Torque in Nm
Centre stand bolt	40 ÷ 45
Side stand fixing bolt	40 ÷ 45

Refer to the table in section "**Suspensions/Swinging arm/Fitting**" for the tightening torques of the swinging arm.

### **FRONT SUSPENSION**

Name	Torque in Nm
Front wheel axle	45 to 50
Fork leg screw	6 - 7
front mudguard to plate fixing screw	4.5 ÷ 7
Fixing screw for mudguard plate to fork	9 ÷ 11
Stem support clamp tightening screws	20 to 25
Fork locking screws cap	15 ÷ 30
Hydraulic rod fixing screw	25 ÷ 35*

### **REAR SUSPENSION**

Name	Torque in Nm
Rear wheel axle	104 to 126
Fixing screw for wheel rim to hub	34 ÷ 38
Right shock absorber lower retainer	40 ÷ 45
Left shock absorber lower retainer	33 ÷ 41
Silencer supporting arm to engine screws (*)	20 to 25
Upper shock absorber retainer	40 ÷ 45

### **FRONT BRAKE**

Name	Torque in Nm
Brake fluid pump-hose fitting	16 - 20
Oil bleed screw	12 - 16
Pad fastening pin	19.6 ÷ 24.5
Screw tightening calliper to support	24 ÷ 27
Brake disc screws	8 to 10
Brake fluid tube-calliper fitting	20 to 25

### **REAR BRAKE**

Name	Torque in Nm
Rear brake calliper-pipe fitting	20 to 25
Rigid / flexible pipe fitting	13 - 18
Rear brake pump-pipe fitting	16 - 20
Rear brake calliper fixing screws	20 to 25
Brake disc screws	8 to 10
Pad fastening pin	19.6 ÷ 24.5

### **MUFFLER**

Name	Torque in Nm
Silencer heat guard fixing screw	4 to 5
Screw for fixing silencer to supporting arm	20 to 25
Lambda probe tightening on exhaust manifold	40 to 50
Exhaust manifold-silencer joint tightening	12÷13
Nut fixing silencer to cylinder head	16 to 18

### **LUBRICATION**

Name	Torque in Nm
Hub oil drainage plug	15 to 17
Oil filter on crankcase fitting	27 to 33
Engine oil drainage plug/ mesh filter	24 to 30
Oil filter	4 to 6

Name	Torque in Nm
Oil pump cover screws	7 - 9
Screws fixing oil pump to the crankcase	5 to 6
Oil pump command sprocket screw	10 to 14
Oil pump cover plate screws	4 to 6
Oil sump screws	10 to 14
Minimum oil pressure sensor	12 to 14

### CYLINDER HEAD

Name	Torque in Nm
Spark plug	12 to 14
Head cover screws	6 - 7
Nuts fixing head to cylinder	$7\pm 1 + 10\pm 1 + 270^\circ$
Head fixing side screws	11 - 12
Starter ground screw	7 to 8.5
Tappet adjustment check nut	6 - 8
Intake manifold screws	11 to 13
Timing chain tensioner slider screw	10 to 14
Starter counterweight support screw	11 to 15
Timing chain tensioner support screw	11 to 13
Timing chain tensioner central screw	5 to 6
Camshaft retention plate screw	4 to 6

### TRANSMISSION

Name	Torque in Nm
Belt support roller screw	11 to 13
Clutch unit nut on driven pulley	45 to 50
Drive pulley nut	75 - 83
Transmission cover screws	11 to 13
Driven pulley shaft nut	54 ÷ 60
Rear hub cap screws	24 to 27

### FLYWHEEL

Name	Torque in Nm
Flywheel cover screw	11 to 13
Stator assembly screws	3 - 4 (Apply LOCTITE medium type 242 threadlock)
Flywheel nut	94 - 102
Pick-up fixing screws	3 to 4
Screw fixing freewheel to flywheel	13 - 15

### CRANKCASE AND CRANKSHAFT

Name	Torque in Nm
Internal engine crankcase bulkhead (transmission-side half shaft) screws	4 to 6
Engine-crankcase coupling screws	11 to 13
Starter screws	11 to 13
Crankcase timing cover screws	3.5 - 4.5 (Apply LOCTITE medium type 242 threadlock)

### COOLING

Name	Torque in Nm
Water pump rotor cover	3 to 4
Screws for water pump rotor driving link	3 to 4
Thermostat cover screws	3 to 4
bleed screw:	3

## Overhaul data

## Assembly clearances

Cylinder - piston assy.

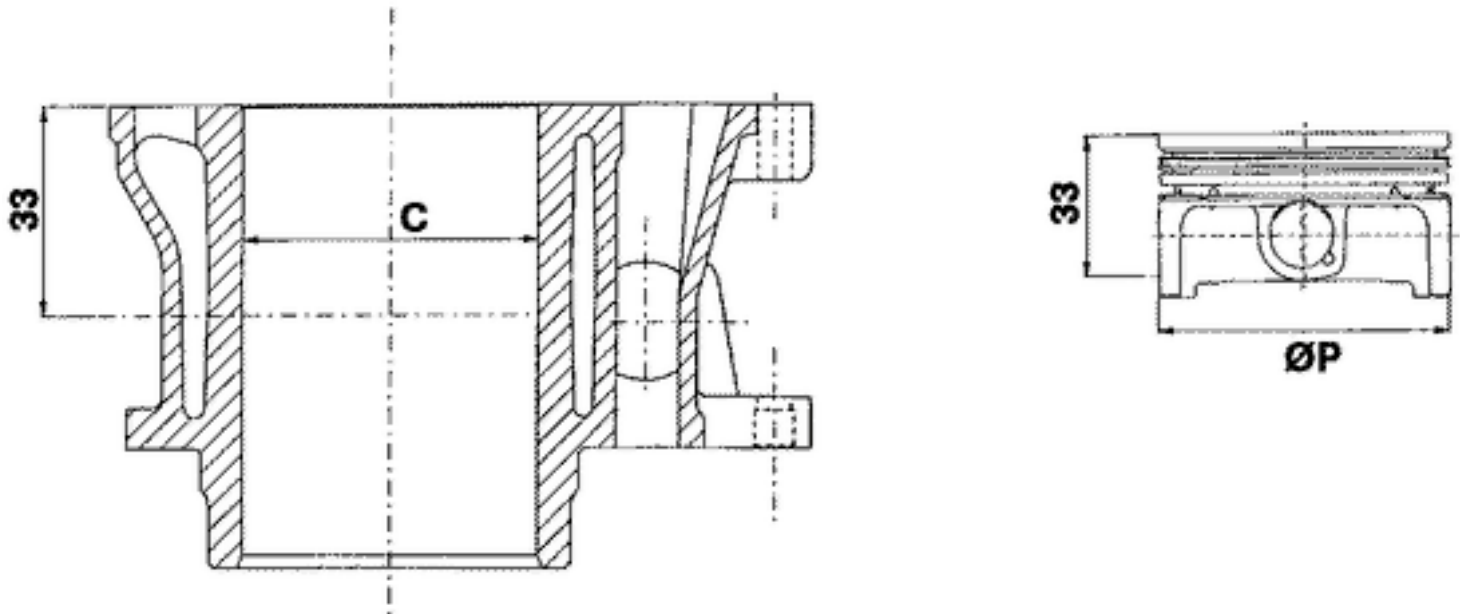

**CYLINDER - PISTON**

Specification	Desc./Quantity
Plunger diameter	74.967 +0.014 -0.014 mm
Cylinder diameter	75 +0.038 +0.01 mm

**COUPLING CATEGORIES**

Name	Initials	Cylinder	Piston	Play on fitting
cylinder-piston	M	75.01 ÷ 75.017	74.953 ÷ 74.960	0.050 ÷ 0.064
cylinder-piston	N	75.017 ÷ 75.024	74.960 ÷ 74.967	0.050 ÷ 0.064
cylinder-piston	O	75.024 ÷ 75.031	74.967 ÷ 74.974	0.050 ÷ 0.064
cylinder-piston	P	75.031 ÷ 75.038	74.974 ÷ 74.981	0.050 ÷ 0.064

N.B.

**THE PISTON MUST BE INSTALLED WITH THE ARROW FACING TOWARDS THE EXHAUST SIDE, THE PISTON RINGS MUST BE INSTALLED WITH THE WORD «TOP» OR THE STAMPED MARK FACING UPWARDS.**

- Measure the outer diameter of the gudgeon pin.

**Characteristic**

**Pin outside diameter**

16 +0 -0.004 mm

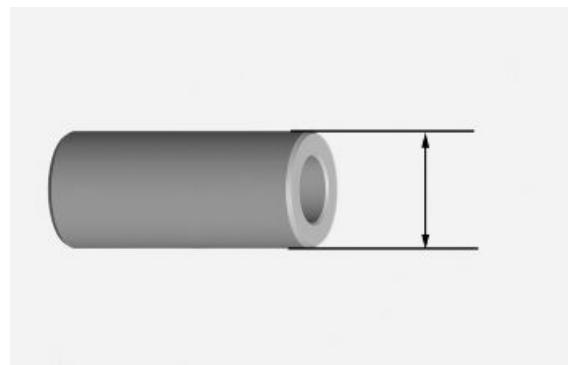

- Measure the diameter of the bearings on the piston.

**Characteristic**

**Standard diameter**

16 +0.006 +0.001 mm

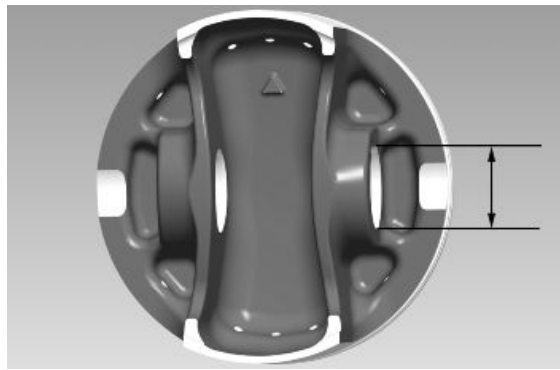

- Calculate the piston pin coupling clearance.

**N.B.**

**THE PIN HOUSINGS HAVE 2 LUBRICATION CHANNELS. FOR THIS REASON, MEASUREMENT MUST BE MADE ACCORDING TO THE PISTON AXIS.**

**Characteristic**

**Standard clearance:**

0.001 - 0.010 mm

- Carefully clean the seal housings.
- Measure the coupling clearance between the sealing rings and the piston grooves using suitable sensors, as shown in the diagram.
- If the clearance is greater than that indicated in the table, replace the piston.

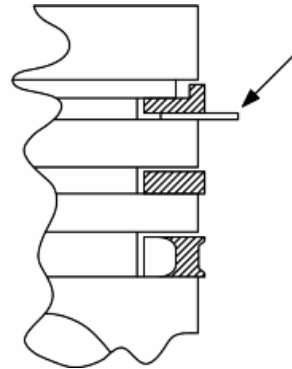

**N.B.**

**MEASURE THE CLEARANCE BY INSERTING THE BLADE OF THE FEELER THICKNESS GAUGE FROM THE SECOND SEAL SIDE.**

**Fitting clearance**

**Top piston ring - standard coupling clearance** 0.015 - 0.06 mm **Top piston ring - maximum clearance allowed after use** 0.07 mm **Middle piston ring - standard coupling clearance** 0.015 - 0.06 mm **Middle piston ring - maximum clearance allowed after use** 0.07 mm **oil scraper ring - standard coupling clearance** 0.015 - 0.06 mm **oil scraper ring - maximum clearance allowed after use** 0.07 mm

- Check that the head coupling surface is not worn or misshapen.
- Pistons and cylinders are classified according to their diameter. The coupling must be made with those of the same type (M-M, N-N, O-O, P-P).



**Characteristic**

**Maximum allowable run-out:**

0.05 mm

**Crankcase - crankshaft - connecting rod**

**CRANKSHAFT**

Titolo	Durata/Valore	Testo Breve (< 4000 car.)	Indirizzo Immagine
Crankshaft		Crankshaft to connecting rod axial clearance	

*Crankshaft to connecting rod axial clearance*

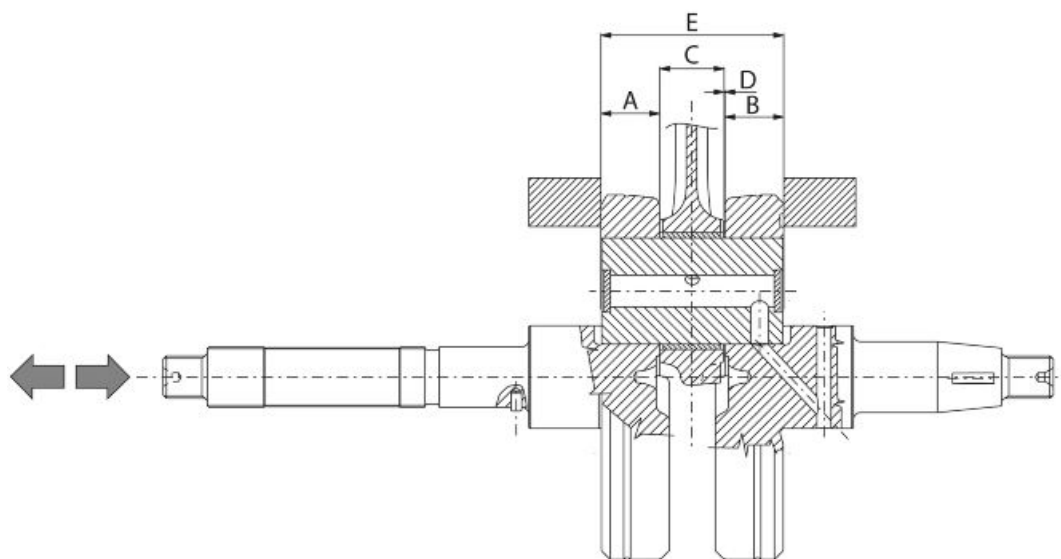

**AXIAL CLEARANCE BETWEEN CRANKSHAFT AND CONNECTING ROD**

Name	Description	Dimensions	Initials	Quantity
Transmissionside half-shaft		16.6 +0-0.05	A	D = 0.20 ÷ 0.50
Flywheel-side halfshaft		16.6 +0-0.05	B	D = 0.20 ÷ 0.50
Connecting rod		18 -0.10 -0.15	C	D = 0.20 ÷ 0.50
Spacer tool		51.4 +0.05	E	D = 0.20 ÷ 0.50

**Diameter of crankshaft bearings.**

Measure the bearings on both axes x-y.

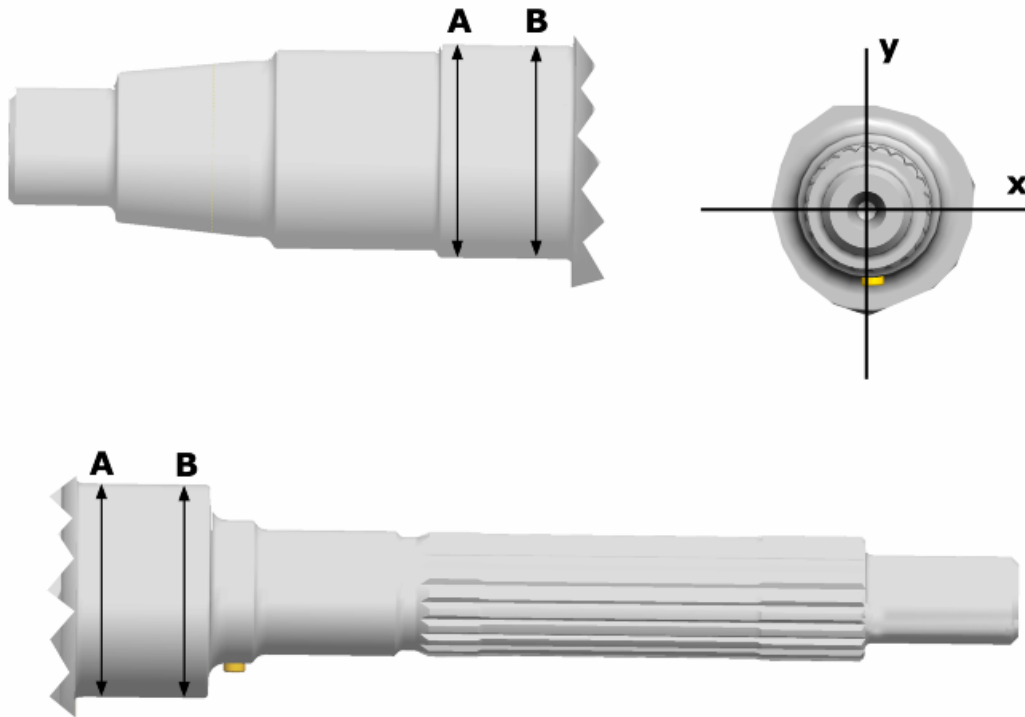

**CRANKSHAFT**

Specification	Desc./Quantity
Crankshaft bearings: Standard diameter: Cat. 1	28.998 ÷ 29.004 mm
Crankshaft bearings: Standard diameter: Cat. 2	29.004 ÷ 29.010 mm



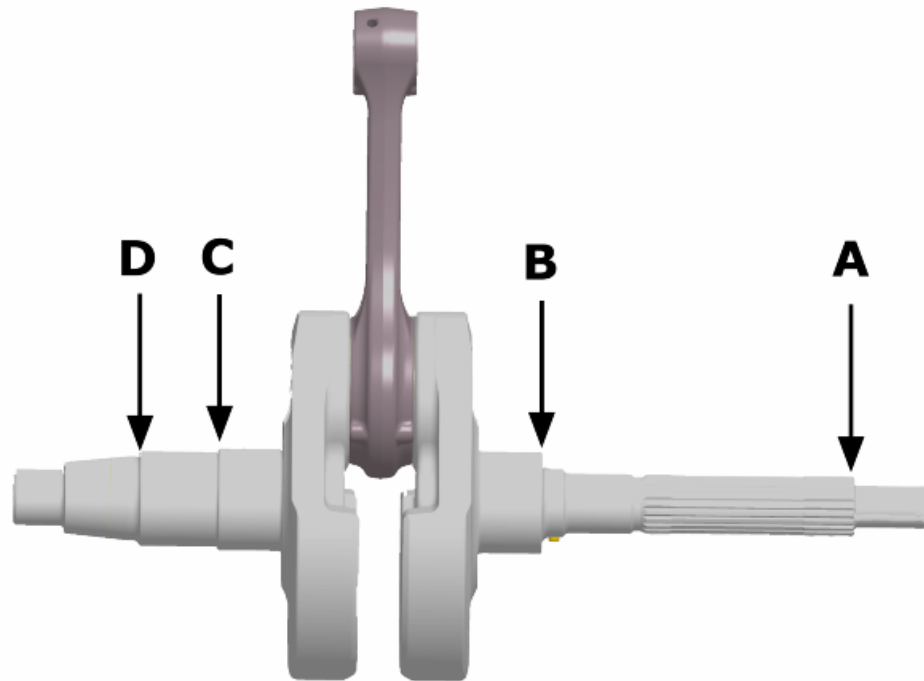

**MAX. ADMISSIBLE DISPLACEMENT**

Specification	Desc./Quantity
A =	0.15 mm
B =	0.010 mm
C =	0.010 mm
D =	0.10 mm

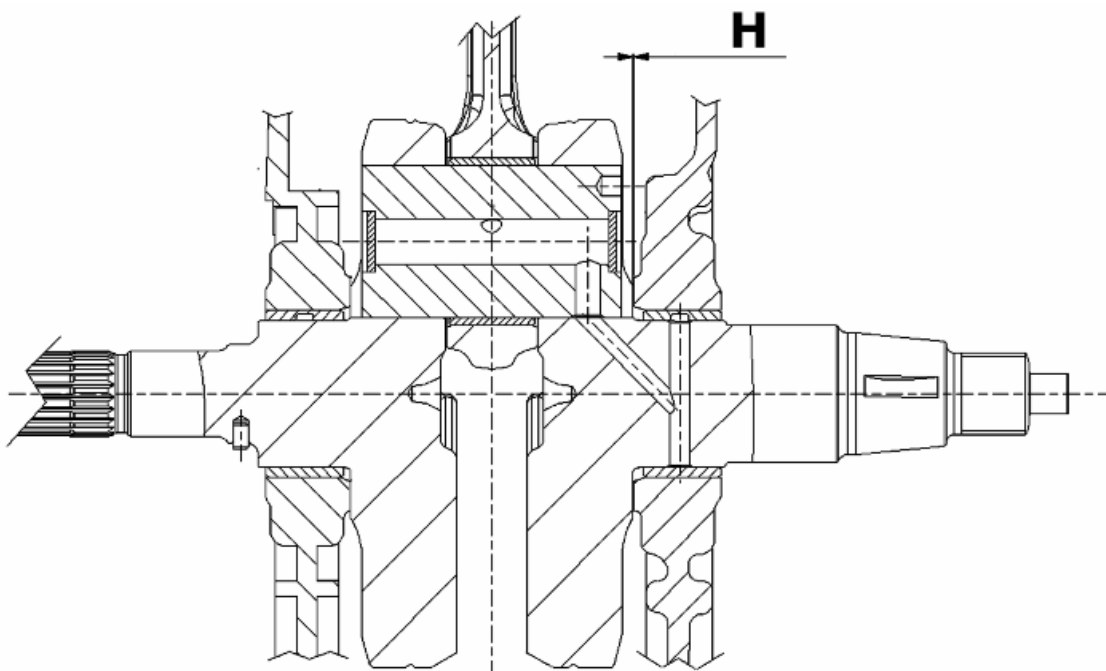

**Characteristic**

**Crankshaft-crankcase axial clearance (H)**

0.15 ÷ 0.43 mm

- Using a bore gauge, measure the connecting rod small end diameter.

**N.B.**

**IF THE CONNECTING ROD SMALL END DIAMETER EXCEEDS THE STANDARD DIAMETER, EXHIBITS WEAR OR OVERHEATING, PROCEED TO REPLACE THE CRANKSHAFT AS DESCRIBED IN THE CRANKCASE AND CRANKSHAFT CHAPTER.**



**Characteristic**

**Standard diameter**

16 +0.025 +0.015 mm

- To obtain a good bushing lubrication it is necessary to have both an optimal lubricating pressure and a good oil flow rate; the bushings must be correctly positioned so as not to obstruct the oil supply channels.
- The main bushings are comprised of two half-bearings, one with holes and channels for lubrication whereas the other is solid.
- The solid half-bearing is intended to stand the thrusts caused by combustion, and for this reason it is arranged opposite the cylinder.
- To prevent shutters in the oil feeding channels, the matching surface of the two half-bearings must be perfectly orthogonal to the cylinder axis, as shown in the figure.
- The oil feeding channel section is also affected by the bushings driving depth compared with the crankshaft axial clearance of the limiting surface.
- Check the inside diameter of the main bushings in the three directions indicated in the diagram.
- Repeat the measurements for the other bushing half. see diagram.
- There are three crankcase versions: with BLUE bushings, with YELLOW bushings and with GREEN bushings.
- There is only one type of main bushing housing hole in the crankcase. The standard bushing diameter after driving is variable on the basis of a coupling selection.
- The bushing housings in the crankcase are classified into 2 categories - Cat. 1 and Cat. 2 - just like those for the crankshaft.
- The main bushings are available in three thickness categories, identified by colour markings, as shown in the table below.

**BUSHINGS**

TYPE	IDENTIFICATION	CRANKSHAFT HALF-BEARING
B	BLUE	1.973 to 1.976
C	YELLOW	1.976 to 1.979
E	GREEN	1.979 to 1.982

**COUPLINGS**

BUSHING CATEGORY	CRANKCASE HALVES CATEGORY	BUSHING INSIDE DIAMETER AFTER FITTING
B	2	29.024 ÷ 29.054
C	1	29.024 ÷ 29.054
	2	29.018 ÷ 29.048
E	1	29.018 ÷ 29.048

Combine the shaft with two category 1 crankwebs with the category 1 crankcase (or cat. 2 with cat. 2). Furthermore a spare crankcase cannot be matched with a crankshaft with mixed categories. The spare crankshaft has half-shafts of the same category.

**CATEGORIES**

CRANKCASE HALVES	ENGINE HALF-SHAFT	BUSHING
Cat. 1	Cat. 1	E
Cat. 2	Cat. 2	B
Cat. 1	Cat. 2	C
Cat. 2	Cat. 1	C

**N.B.**

DO NOT TAKE THE MEASUREMENT ON THE TWO HALF-SHELL COUPLING SURFACE SINCE THE ENDS ARE RELIEVED TO ALLOW BENDING DURING THE DRIVING OPERATION.

**N.B.**

CRANKCASES FOR REPLACEMENTS ARE SELECTED WITH CRANKCASE HALVES OF THE SAME CATEGORY AND ARE FITTED WITH CATEGORY C BUSHINGS (YELLOW)

**Characteristic**

**Crankshaft-bushing maximum clearance admitted:**

0.08 mm

**Diameter of crankcase without bushing**

**CAT. 1:** 32.959 ÷ 32.965 mm

**CAT. 2:** 32.953 ÷ 32.959 mm

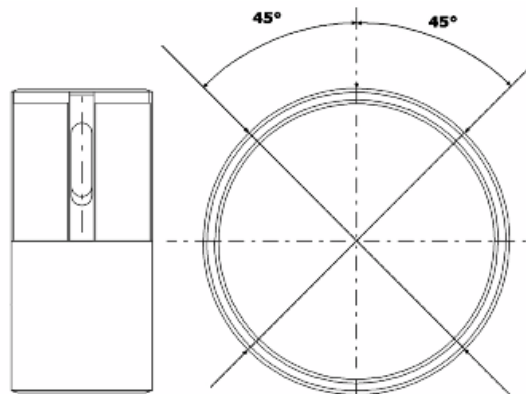

**THE CRANKSHAFT** is available in two **CATEGORIES**:

**Characteristic**

**Crankshaft category:**

**CAT. 1 - CAT. 2**

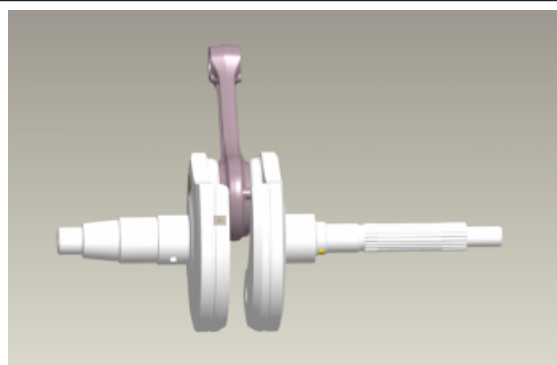

**CRANKSHAFT CATEGORY IDENTIFICATION:**

The identification is indicated on the counterweight shoulder «\*1 - \*2», if carried out with micropinholing. Otherwise, «1 - 2» if done manually with an electric pen. The spare part identification is located on the package with a **drawing number** plus **FC1/FC2** or **(001/002)**.

If a crankshaft comprising two half-shafts of different categories needs to be replaced, also replace both crankcase halves, combining the two components (Shaft and Crankcase) featuring the same category.

## Cylinder Head

Before performing head service operations, thoroughly clean all coupling surfaces. Note the position of the springs and the valves so as not to change the original position during refitting

- Using a trued bar and a feeler gauge check that the cylinder head surface is not worn or distorted.

### Characteristic

#### Maximum allowable run-out:

0.1 mm



- In case of faults, replace the head.
- Check the sealing surfaces for the intake and exhaust manifold.
- Check that the camshaft and the rocking lever pin capacities exhibit no wear.
- Check that the head cover surface is not worn.
- Check that the coolant seal plug exhibits no oxidation.

- Insert the valves into the cylinder head.
- Alternatively check the intake and exhaust valves.
- The test is carried out by filling the manifold with petrol and checking that the head does not ooze through the valves when these are just pressed with the fingers.

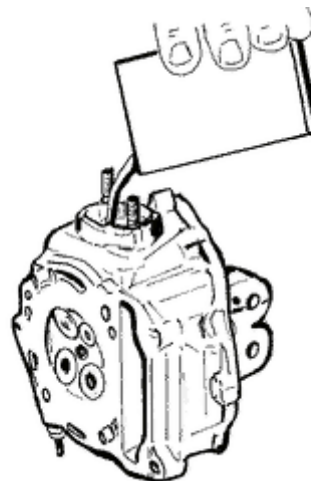

Measure the camshaft bearing seats and rocking lever support pins with a bore meter

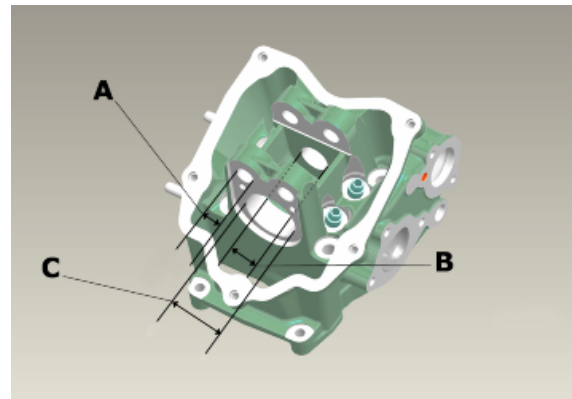

**HEAD BEARINGS**

Specification	Desc./Quantity
bearing «A»	Ø 12.000 - 12.018 mm
bearing «B»	Ø 20.000 ÷ 20.021 mm
bearing «C»	Ø 37.000 - 37.025 mm

Measure the unloaded spring length

**Characteristic**

**Standard length**

40.2 mm

**Allowable limit after use:**

38.2 mm

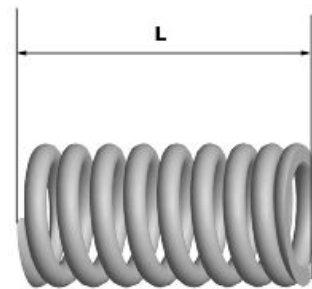

- Clean the valve seats of any carbon residues.
- Using the Prussian blue, check the width of the impression on the valve seat "V".

**Characteristic**

**Standard value:**

1 - 1.3 mm

**Admissible limit:**

1.6 mm

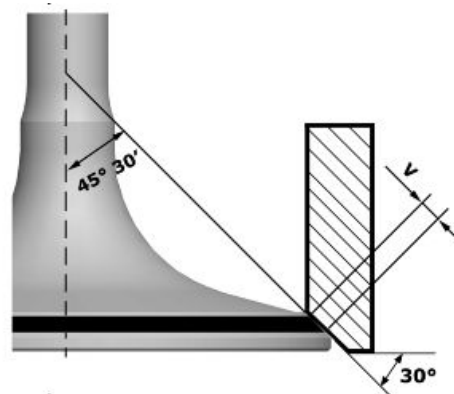

- If the impression width on the valve seat is larger than the prescribed limits, true the seats with a 45° mill and then grind.
- In case of excessive wear or damage, replace the head.

**STANDARD VALVE LENGTH**

Specification	Desc./Quantity
Valve check Standard length	Intake: 94.6 mm
Valve check Standard length	Exhaust: 94.4 mm

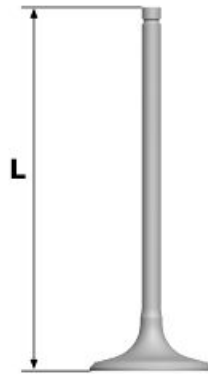

- Measure the diameter of the valve stems in the three positions indicated in the diagram.

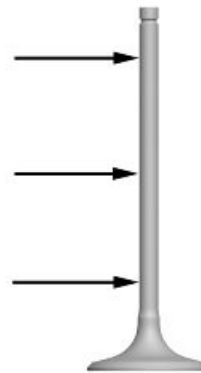

**STANDARD DIAMETER**

Specification	Desc./Quantity
Intake:	4.987 - 4.972 mm
Exhaust:	4.975 - 4.960 mm

**MINIMUM ADMISSIBLE DIAMETER**

Specification	Desc./Quantity
Intake:	4.96 mm
Exhaust:	4.945 mm

- Calculate the clearance between valve and valve guide.

- Check the deviation of the valve stem by resting it on a «V» shaped abutment and measuring the extent of the deformation with a dial gauge.

**Characteristic**

**Limit values admitted:**

0.1 mm

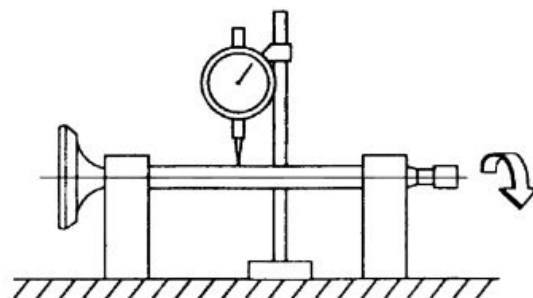

- Check the concentricity of the valve head by arranging a dial gauge at right angle relative to the valve head and rotate it on a "V" shaped abutment.

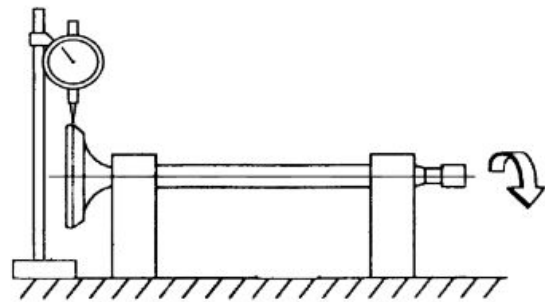

**Characteristic**  
**Admissible limit:**  
 0.03 mm

Measure the valve guide.

**Characteristic**  
**Valve guide:**  
 5 +0.012 mm

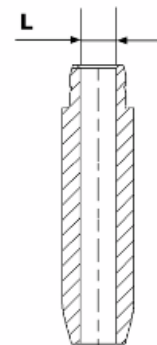

- After measuring the valve guide diameter and the valve stem diameter, check clearance between guide and stem.



**INTAKE**

Specification	Desc./Quantity
Standard clearance:	0.013 - 0.04 mm
Admissible limit:	0.08 mm

**OUTLET**

Specification	Desc./Quantity
Standard clearance:	0.025 to 0.052 mm
Admissible limit:	0.09 mm

- Check that there are no signs of wear on the faying surface with the articulated set screw terminal.

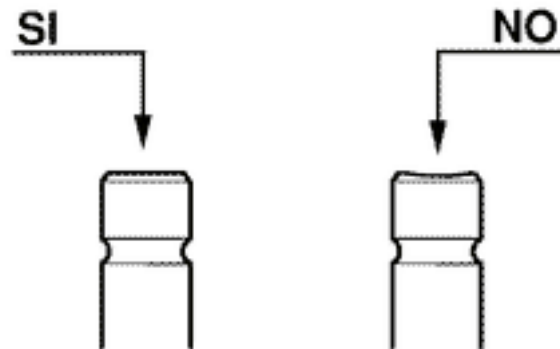

- If no anomalies are found during the above checks, you can use the same valves. To obtain better sealing performance, grind the valve seats. Grind the valves gently with a fine-grained lapping compound. During the grinding, keep the cylinder head with the valve axes in a horizontal position. This will prevent the lapping compound residues from penetrating between the valve stem and the guide (see figure).



**CAUTION**

**TO AVOID SCORING THE FAYING SURFACE, DO NOT KEEP ROTATING THE VALVE WHEN NO LAPPING COMPOUND IS LEFT. CAREFULLY WASH THE CYLINDER HEAD AND THE VALVES WITH A SUITABLE PRODUCT FOR THE TYPE OF LAPPING COMPOUND BEING USED.**

**CAUTION**

**DO NOT REVERSE THE FITTING POSITIONS OF THE VALVES (RIGHT - LEFT).**

- Check that the camshaft bearings exhibit no scores or abnormal wear.
- Using a micrometer, measure the camshaft bearings.

**STANDARD DIAMETER**

Specification	Desc./Quantity
Camshaft check: Standard diameter	Bearing A Ø: 36.95 ÷ 36.975 mm
Camshaft check: Standard diameter	Bearing B diameter: 19.959 ÷ 19.98 mm

**MINIMUM ADMISSIBLE DIAMETER**

Specification	Desc./Quantity
Camshaft check: Minimum admissible diameter	Bearing A Ø: 36.94 mm
Camshaft check: Minimum admissible diameter	Bearing B diameter: 19.950 mm



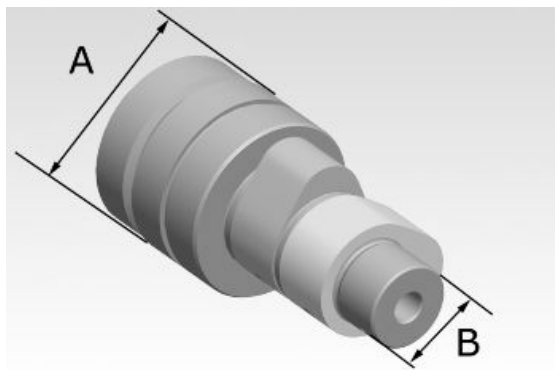

-Using a gauge, measure the cam height.

**STANDARD HEIGHT**

Specification	Desc./Quantity
Camshaft check: Standard height	Intake: 30.285 mm
Camshaft check: Standard height	Exhaust: 29.209 mm

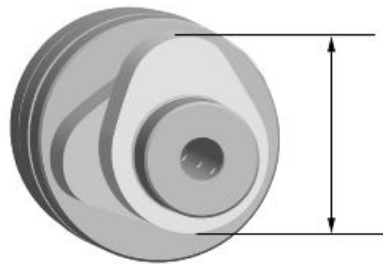

Check the axial clearance of the camshaft

**CAMSHAFT AXIAL CLEARANCE**

Specification	Desc./Quantity
Camshaft check: Standard axial clearance:	0.11 - 0.41 mm
Camshaft check: Maximum admissible axial clearance	0.42 mm

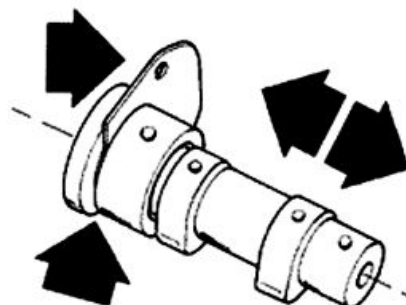

- Measure the outside diameter of the rocking lever pins
- Check the rocking lever pins do not show signs of wear or scoring.
- Measure the internal diameter of each rocking lever.

Check there are no signs of wear on the pad from contact with the cam and on the jointed adjustment plate.

**ROCKING LEVERS AND PIN DIAMETER:**

Specification	Desc./Quantity
Rocking lever inside diameter: Standard diameter	Diameter 12.000 - 12.011 mm
Rocking lever pin diameter: Standard diameter	Diameter 11.977 - 11.985 mm



**Slot packing system**

**Characteristic**

**Compression ratio**

10.5 ÷ 11.5 : 1

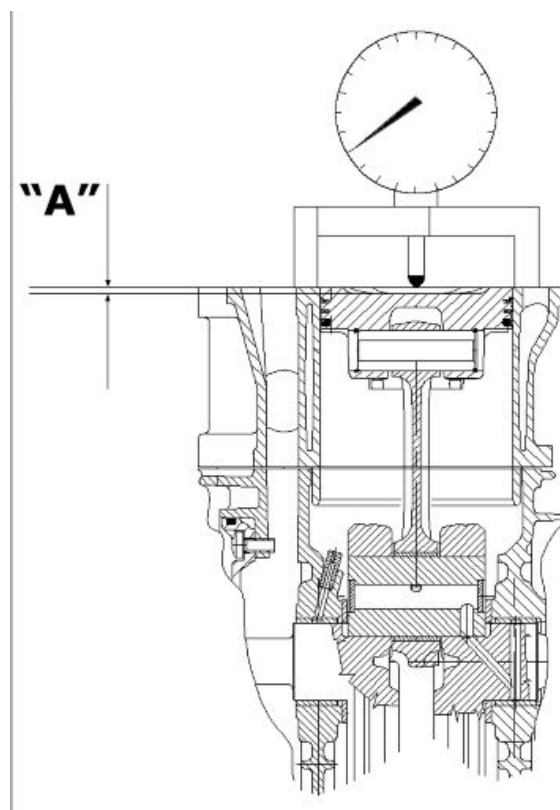

Measurement "A" to be taken is a value of piston re-entry, it indicates by how much the plane formed by the piston crown falls below the plane formed by the top of the cylinder. The further the piston falls inside the cylinder, the less the base gasket to be applied (to recover the compression ratio) and vice versa.

N.B.

**MEASUREMENT "A" MUST BE TAKEN WITHOUT ANY GASKET FITTED BETWEEN THE CRANK-CASE AND CYLINDER AND AFTER RESETTING THE DIAL GAUGE, EQUIPPED WITH A SUPPORT, ON A GROUND PLANE**

### ENGINE 300 SHIMMING

Name	Measure A	Thickness
SHIMMING	3.70 - 3.60	0.4 ± 0.05
SHIMMING	3.60 - 3.40	0.6 ± 0.05
SHIMMING	3.40 - 3.30	0.8 ± 0.05

## Products

### RECOMMENDED PRODUCTS TABLE

Product	Description	Specifications
AGIP ROTRA 80W-90	Rear hub oil	SAE 80W/90 Oil that exceeds the requirements of API GL3 specifications
AGIP CITY HI TEC 4T	Oil to lubricate flexible transmissions (throttle control)	Oil for 4-stroke engines
AGIP FILTER OIL	Oil for air filter sponge	Mineral oil with specific additives for increased adhesiveness
AGIP GP 330	Grease for brake lever, gas	White calcium complex soap-based spray grease with NLGI 2; ISO-L-XBCIB2
AGIP CITY HI TEC 4T	Engine oil	SAE 5W-40, API SL, ACEA A3, JASO MA Synthetic oil
AGIP BRAKE 4	Brake fluid	FMVSS DOT 4 Synthetic fluid
AGIP PERMANENT SPEZIAL	coolant	Monoethylene glycol-based antifreeze fluid, CUNA NC 956-16

### UNIT OF MEASURE - CONVERSION - ENGLISH SYSTEM TO INTERNATIONAL SYSTEM (IS).







Specification	Desc./Quantity
1 Inch (in)	25.4 Millimetres (mm)
1 Foot (ft)	0.305 Metres (m)
1 Mile (mi)	1.609 Kilometres (km)
1 US Gallon (USgal)	3.785 Litres (l)
1 Pound (lb)	0.454 Kilograms (kg)
1 Cubic inch (in <sup>3</sup> )	16.4 Cubic centimetres (cm <sup>3</sup> )
1 Foot pound (ft lb)	1,356 Newton metres (Nm)
1 Mile per hour (mi/h)	1.602 Kilometres per hour (km/h)
1 Pound per square inch (PSI)	0.069 (bar)
1 Fahrenheit (°F)	32+(9/5) Celsius (°C)

## INDEX OF TOPICS

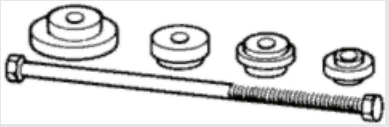
TOOLING

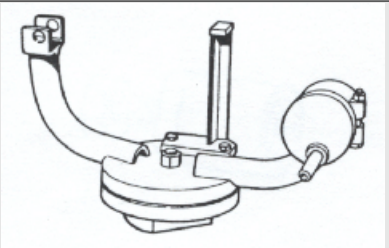
TOOL

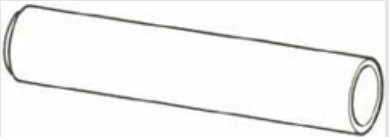
**SPECIFIC TOOLS**

Stores code	Description	
001330Y	Tool for fitting steering seats	
001467Y014	Calliper to extract ø 15-mm bearings	
005095Y	Engine support	
002465Y	Calliper for circlips	
006029Y	Punch for fitting steering bearing seat on steering tube	
020004Y	Punch for removing steering bearings from headstock	
020055Y	Wrench for steering tube ring nut	

Stores code	Description	
020074Y	Support base for checking crankshaft alignment	
020150Y	Air heater mounting	
020151Y	Air heater	
020193Y	Oil pressure check gauge	
020262Y	Crankcase splitting plate	
020263Y	Driven pulley assembly sheath	

---

Stores code	Description
-------------	-------------

---

020306Y	Punch for assembling valve seal rings
---------	---------------------------------------



020329Y	Mity-Vac vacuum-operated pump
---------	-------------------------------

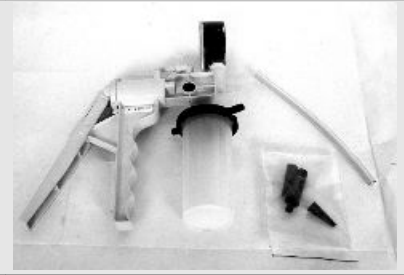

020330Y	Stroboscopic light to check timing
---------	------------------------------------





020331Y	Digital multimeter
---------	--------------------



020332Y	Digital rpm indicator
---------	-----------------------



Stores code	Description	
020648Y	Single battery charger	

020335Y	Magnetic mounting for dial gauge	
---------	----------------------------------	---

020357Y	32x35-mm Adaptor	
020359Y	42x47-mm Adaptor	





020360Y	52x55-mm Adaptor	
---------	------------------	--

020363Y	20-mm guide	
---------	-------------	---



Stores code	Description	
020375Y	28 x 30 mm adaptor	







020376Y	Adaptor handle	
---------	----------------	---



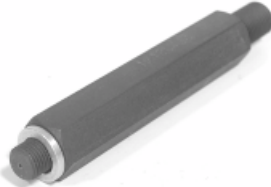

020382Y	Valve cotters equipped with part 012 removal tool	
---------	---	--

020382Y011	adapter for valve removal tool	
------------	--------------------------------	---

020393Y	Piston assembly band	
---------	----------------------	---

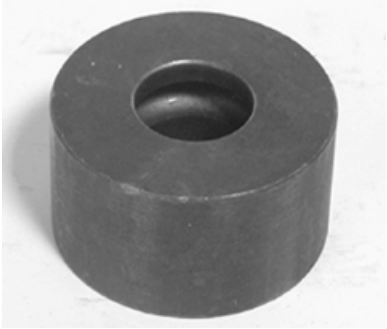
020412Y	15-mm guide	
---------	-------------	---

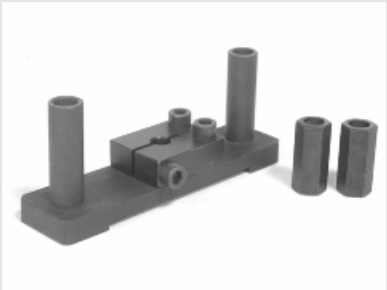
Stores code	Description	
020423Y	Driven pulley lock wrench	
020424Y	Driven pulley roller casing fitting punch	
020426Y	Piston fitting fork	
020431Y	Valve oil seal extractor	
020434Y	Oil pressure check fitting	
020444Y	Tool for fitting/ removing the driven pulley clutch	

Stores code	Description	
020456Y	Ø 24 mm adaptor	
020477Y	37 mm adaptor	
020483Y	30-mm guide	
020489Y	Hub cover support stud bolt kit	
020428Y	Piston position check mounting	
020680Y	Diagnosis Tool	

Stores code	Description	
020621Y	HV cable extraction adaptor	
020481Y	Control unit interface wiring	
001467Y035	Bearing housing, out ø 47 mm	
020626Y	Driving pulley lock wrench	
001467Y013	Calliper to extract ø 15-mm bearings	
020627Y	Flywheel lock wrench	

Stores code	Description	
020467Y	Flywheel extractor	





020454Y	Tool for fitting piston pin stops (200 - 250)	
---------	---	---

020622Y	Transmission-side oil seal punch	
---------	----------------------------------	--

020480Y	Petrol pressure check kit	
---------	---------------------------	---

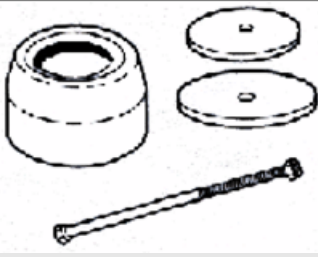
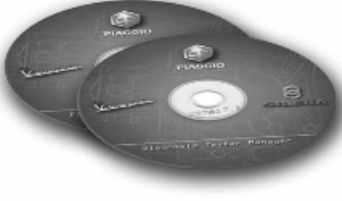
020244Y	15-mm diameter punch	
---------	----------------------	---

020115Y	Ø 18 punch	
---------	------------	---

Stores code	Description	
020271Y	Tool for removing-fitting silent bloc	
020638Y	250 I ENGINE SOFTWARE E. - ABS	
020469Y	Reprogramming kit for scooter diagnostic tester	
020487Y	Fork oil seal extractor	
020458Y	Puller for lower bearing on steering tube	

# INDEX OF TOPICS

**MAINTENANCE**

**MAIN**

**RESET SERVICE WARNING LIGHT**

At vehicle ignition, immediately after the ignition check, if there are less than 300 km (187.5 miles) to the next scheduled service, the corresponding icon flashes for 5 seconds. Once the service mileage has been reached, the icon remains steadily on until it is reset.

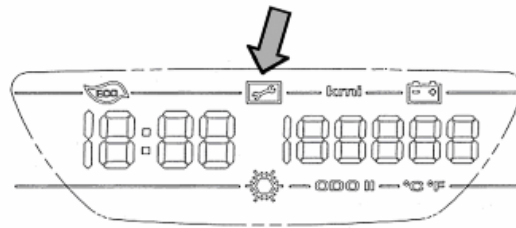

The service is reset by holding down the MODE button to the key connection for more than 10 seconds; for the first 5 seconds, the instrument panel will not give any signal; for the next 5 seconds the key icon will blink at frequency of 1 Hz. If the button is released before 10 seconds, the service is not reset.

**Maintenance chart**

**MAINTENANCE TABLE**

*I: INSPECT AND CLEAN, ADJUST, LUBRICATE OR REPLACE, IF NECESSARY C: CLEAN, R: REPLACE, A: ADJUST, L: LUBRICATE*

*\* Replace every 2 years*

*\*\* Clean frequently in cases of intensive use on gravel roads*

Km x 1,000	1	5	10	15	20	25	30	35	40	45	50	55	60	65	70	75	80
Driven pulley roller casing			L		L		L		L		L		L		L		L
Safety fasteners	I		I				I				I				I		
Ignition spark plug			R		R		R		R		R		R		R		R
Centre stand bracket		L	L	L	L	L	L	L	L	L	L	L	L	L	L	L	L
Drive belt				R			R			R			R			R	
Throttle control	A		A		A		A		A		A		A		A		A
Air filter/CVT filter **			C		C		C		C		C		C		C		C
Oil filter	R		R		R		R		R		R		R		R		R
Valve clearance					A				A				A				A
Electrical system and battery	I		I		I		I		I		I		I		I		I
Coolant level *	I		I		I		I		I		I		I		I		I
Brake fluid *	I		I		I		I		I		I		I		I		I
Engine oil	R	I	R	I	R	I	R	I	R	I	R	I	R	I	R	I	R
Hub oil	R		I		R		I		R		I		R		I		R
Brake pads	I	I	I	I	I	I	I	I	I	I	I	I	I	I	I	I	I
Sliding shoes / CVT rollers			R		R		R		R		R		R		R		R
Tyre pressure and wear	I		I		I		I		I		I		I		I		I
Vehicle road test	I		I		I		I		I		I		I		I		I
Suspension	I		I		I		I		I		I		I		I		I
Steering	A		I		I		I		I		I		I		I		I
Time	60'	10'	10 0'	45'	15 0'	10'	14 0'	10'	15 0'	45'	10 0'	10'	19 0'	10'	10 0'	45'	15 0'



## Spark plug

Proceed as follows:

- Remove the case that grants access to the spark plug located on the right side fairing by unscrewing the indicated screw.
- Disconnect cap «A» from the spark plug HV cable by turning it clockwise until releasing it from the retainer.
- Unscrew the spark plug using the wrench supplied.
- When refitting, place the spark plug into the hole at the corresponding angle and finger tighten it as far as it will go. Use the wrench only to tighten it.
- Place cap «A» fully over the spark plug, making sure it is in the retainer again.

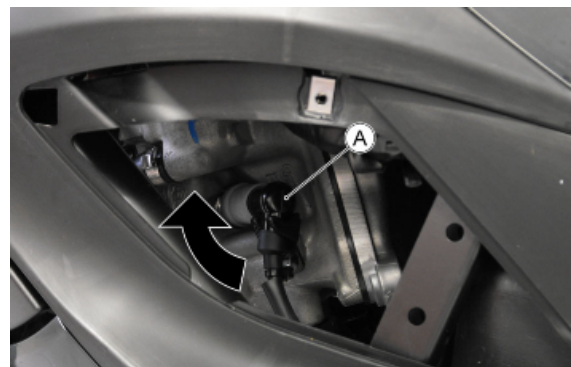

### WARNING



**SPARK PLUG MUST BE REMOVED WHEN THE ENGINE IS COLD. REPLACE THE SPARK PLUG AS INDICATED IN THE SCHEDULED MAINTENANCE TABLE. THE USE OF ELECTRONIC CENTRAL UNITS AND OF NON-COMPLIANT ELECTRONIC IGNITIONS OR SPARK PLUGS OTHER THAN THOSE PRESCRIBED MAY SERIOUSLY DAMAGE THE ENGINE.**

### N.B.

**USE OF SPARK PLUGS OTHER THAN THE INDICATED TYPE OR UNSHIELDED SPARK PLUG CAPS CAN LEAD TO FAULTS IN THE VEHICLE'S ELECTRICAL SYSTEM.**

## Hub oil

### Check

- Place the vehicle on the centre stand on flat ground;
- Remove the oil dipstick «A», dry it with a clean cloth and put it back into its hole **tightening it completely**;

Remove the dipstick and check that the oil level is slightly over the second notch starting from the lower end; if the level is under the MAX. mark, it needs to be filled with the right amount of hub oil.

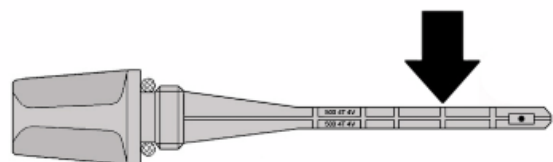

- Screw up the oil dipstick again and make sure it is locked properly into place.



## Replacement

- Remove the oil filler cap «A».
- Unscrew the oil drainage cap «B» and drain out all the oil.
- Screw in the drainage cap again and fill the hub with the prescribed oil.

### Recommended products

#### AGIP ROTRA 80W-90 Rear hub oil

SAE 80W/90 Oil that exceeds the requirements of API GL3 specifications

### Characteristic

#### Rear hub oil

Capacity approximately 250 cc

### Locking torques (N\*m)

Hub oil drainage screw 15 to 17 Nm

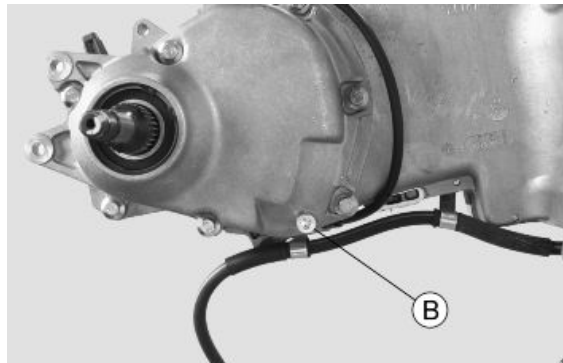

## Air filter

To access the air filter:

- Unscrew the three screws «A» and remove the air filter cover.
- Unscrew the other six screws «B» and remove the air filter cover.



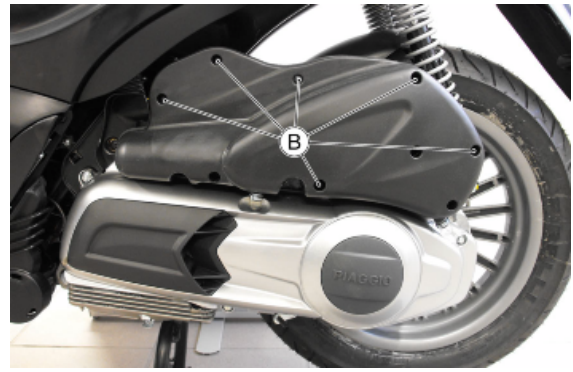

1. Wash the sponge with water and neutral soap.
2. Dry it with a clean cloth and small blasts of compressed air.
3. Soak the sponge with a mixture of 50% petrol and 50% specified oil.
4. Gently squeeze the filter element without twisting it, let it drip and then refit it.

**CAUTION**



**IF THE VEHICLE IS USED ON DUSTY ROADS IT IS NECESSARY TO CARRY OUT MAINTENANCE CHECKS OF THE AIR FILTER MORE OFTEN TO AVOID DAMAGING THE ENGINE.**

**Recommended products**

**AGIP FILTER OIL Oil for air filter sponge**

Mineral oil with specific additives for increased adhesiveness



## Engine oil

### Replacement

Change oil and replace filter as indicated in the scheduled maintenance table.

- In order to facilitate oil drainage, unscrew the cap/dipstick «A».

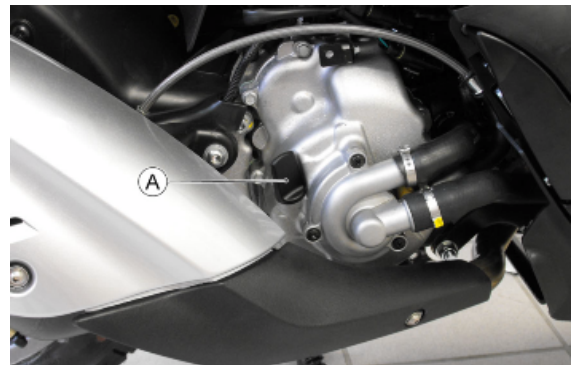

- Unscrew the mesh pre-filter drainage plug «B» on the flywheel side and let the oil drain off.
- Once all the oil has drained through the drainage hole, unscrew and remove the oil cartridge filter «C».

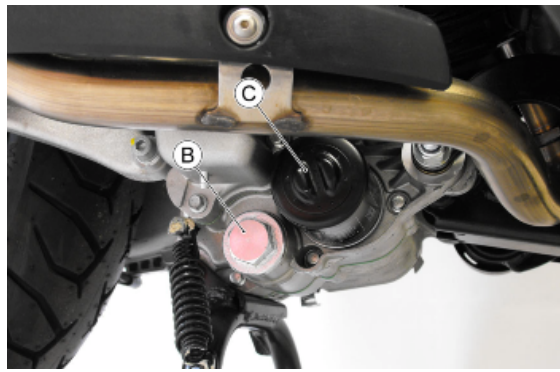

Make sure the pre-filter and drainage plug O-rings are in good conditions. Lubricate them and refit the mesh filter and the oil drainage plug, screwing them up to the prescribed torque.

Refit the new cartridge filter being careful to lubricate the O-ring before fitting it.

Add the recommended engine oil through plug «A». Then start up the vehicle, let it run for a few minutes and shut it off. After five minutes check the level and if necessary top up without exceeding the **MAX** level. The cartridge filter must be replaced every time the oil is changed.

**N.B.**

**THE ENGINE MUST BE HOT WHEN THE OIL IS CHANGED.**

### Recommended products

#### AGIP CITY HI TEC 4T Engine oil

SAE 5W-40 Synthetic oil that exceed the requirements of API SL, ACEA A3, JASO MA specifications

### Characteristic

#### Engine oil

1.3 l



---

## Check

This operation **must be carried out with the engine cold** and following the procedure below:

- Place the vehicle on its centre stand and on flat ground.
- Make sure the adjustment of the rear suspension is set to the minimum preloading position.
- Unscrew the cap/dipstick «A», dry it with a clean cloth and reinsert it, **by screwing it in completely**.



- Remove the cap/dipstick «A» again and check that the level is between the **MAX** and **MIN** marks. top-up, if required.

If the check is carried out after the vehicle has been used, and therefore with a hot engine, the level line will be lower; in order to carry out a correct check, wait at least 10 minutes after the engine has been stopped so as to get the correct level.



### Oil top-up

The oil should be topped up after having checked the level and in any case by adding oil without exceeding the **MAX** level indicated on the cap/ dipstick. Restoring the level from **MIN** to **MAX** requires approximately 400 cm<sup>3</sup> of oil.

---

## Engine oil filter

The cartridge filter must be replaced every time the oil is changed. Use new oil of the recommended type for topping up and changing purposes.

Make sure the pre-filter and drainage plug O-rings are in good conditions. Lubricate them and refit the mesh filter and the oil drainage plug, screwing them up to the prescribed torque. Refit the new cartridge filter being careful to lubricate the O-ring before fitting it. Change the engine oil.

### Recommended products

#### AGIP CITY HI TEC 4T Engine oil

SAE 5W-40 Synthetic oil that exceed the requirements of API SL, ACEA A3, JASO MA specifications

---

---

## Oil pressure warning light

The vehicle is equipped with a telltale light on the dashboard that lights up when the key is turned to the «ON» position. However, this light should switch off once the engine has been started.

**If the light turns on during braking, at idling speed or while turning a corner, it is necessary to check the oil level and the lubrication system.**

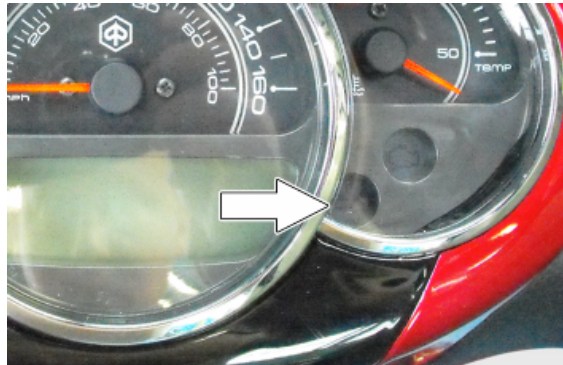

---

## Cooling system

---

### Level check

Check coolant when the engine is cold and as indicated in the scheduled maintenance tables, following the steps below.

- Set the vehicle upright on the stand and remove the cover by undoing screw «A».



- Remove the expansion tank cover «B» by turning it anticlockwise.



- Look inside the expansion tank and check that the level is between **MIN** and **MAX**. Top up if the coolant is below the **MIN** level.

If the level is not correct, proceed to top-up when the engine is cold. If it is necessary to top up the coolant frequently, or if the expansion tank is completely dry, you should look for the cause in the cooling system.

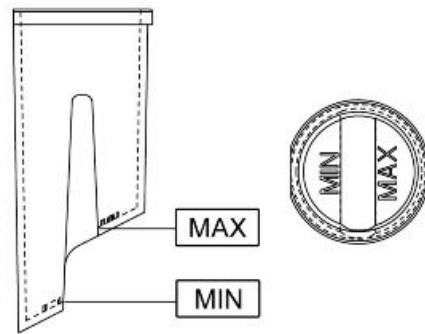

#### WARNING



**TO AVOID THE RISK OF SCALDING, DO NOT UNSCREW THE EXPANSION TANK COVER WHILE THE ENGINE IS STILL HOT.**

#### WARNING



**IN ORDER TO AVOID HARMFUL FLUID LEAKS WHILE RIDING, IT IS IMPORTANT TO MAKE SURE THAT THE LEVEL DOES NOT EXCEED THE REFERENCE TONGUE TOO MUCH.**

**TO ENSURE CORRECT ENGINE OPERATION, KEEP THE RADIATOR GRILLE CLEAN.**

#### Recommended products

##### AGIP PERMANENT SPEZIAL coolant

Monoethylene glycol-based antifreeze fluid, CU-NA NC 956-16

## Braking system

### Level check

The front and rear brake fluid reservoirs are both positioned on the handlebar. Proceed as follows:

- Rest the vehicle onto the centre stand, with the handlebar centred.
- Check the fluid level through the sight glass «A».

A certain lowering of the level is caused by wear on the brake pads.

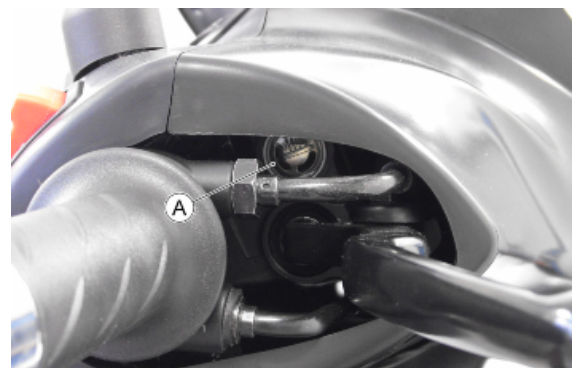

## Top-up

For topping-up, proceed as follows:

- Remove the mirrors unscrewing them from their seats
- Unscrew the two screws «A» and remove the pressure covering.
- Unscrew the two screws «B» and, working on both sides of the vehicle, unscrew the screw «C».
- Using a flat-headed screwdriver, detach the fastener tab as shown in the figure, accessing the tab via the indicated slit.
- Insert the screwdriver between the two covers, as indicated in the figure, and detach the upper fastener tab. Move the rear handlebar cover aside.
- Unscrew the two screws «D» and remove the front handlebar cover releasing the front headlight connector
- Unscrew the two screws «E» and remove the cap «F» of the brake pump to top up to the optimum level.

### WARNING

BRAKING CIRCUIT FLUID IS HIGHLY CORROSIVE; DO NOT LET IT COME INTO CONTACT WITH PAINTED PARTS.

### CAUTION

ONLY USE DOT 4-CLASSIFIED BRAKE FLUID.

### WARNING

THE BRAKE FLUID IS HAZARDOUS: IN CASE OF ACCIDENTAL CONTACT, WASH OFF WITH WATER.

### WARNING

THE BRAKING CIRCUIT LIQUID IS HYGROSCOPIC, AND ABSORBS THE HUMIDITY OF SURROUNDING AIR. IF THE HUMIDITY IN THE BRAKING FLUID EXCEEDS A CERTAIN VALUE, IT WILL LEAD TO INEFFICIENT BRAKING. NEVER USE BRAKING FLUID KEPT IN CONTAINERS THAT HAVE ALREADY BEEN OPENED, OR PARTIALLY USED.

### Recommended products

**Brake fluid Brake fluid**

FMVSS DOT 4 Synthetic fluid

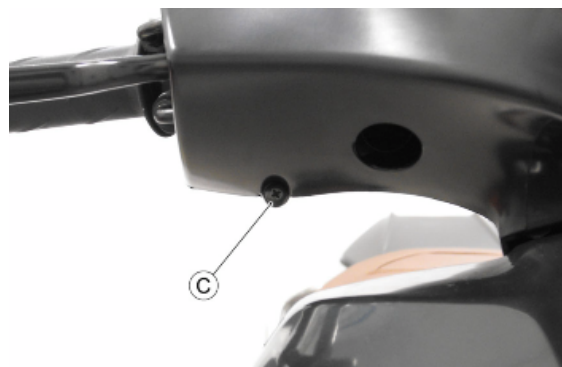



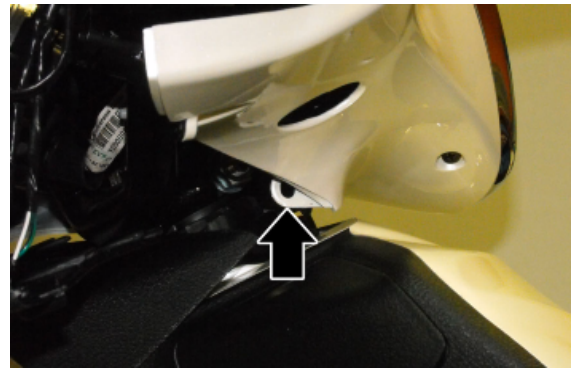

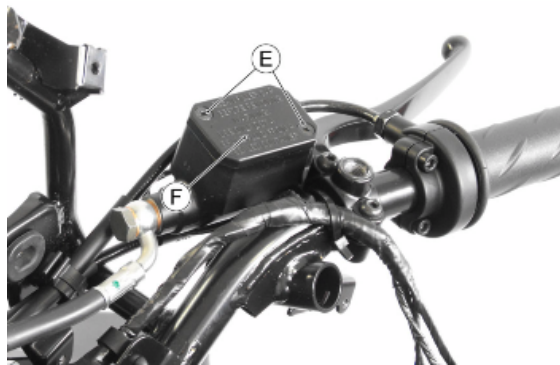

## Headlight adjustment

Proceed as follows:

- Position the vehicle in running order and with the tyres inflated to the prescribed pressure, onto a flat surface, 10 m away from a half-lit white screen; ensure that the longitudinal axis of the vehicle is perpendicular to the screen;

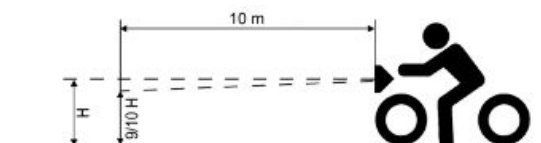

- Turn on the headlight and check that the border-line of the projected light beam on the screen is not higher than 9/10 or lower than 7/10 of the distance from the ground to the centre of the vehicle head-lamp;

- Otherwise, adjust the headlight. Unscrew the two screws «A» and remove the pressure covering. Screw in the screw «B» to lower the light beam, unscrew the screw «B» to raise the light beam.

**N.B.**

**THE ABOVE PROCEDURE COMPLIES WITH THE EUROPEAN STANDARDS REGARDING MAXIMUM AND MINIMUM HEIGHT OF LIGHT BEAMS. REFER TO THE STATUTORY REGULATIONS IN FORCE IN EVERY COUNTRY WHERE THE VEHICLE IS USED.**

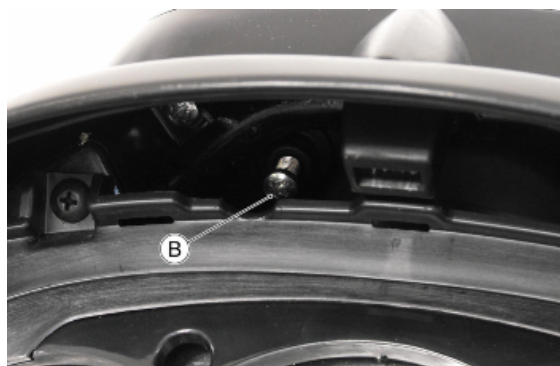
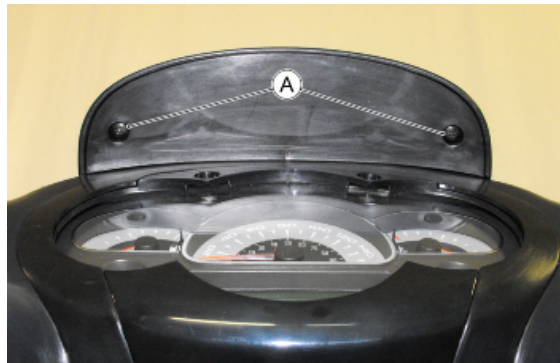

## INDEX OF TOPICS

TROUBLESHOOTING

TROUBL

This section makes it possible to find what solutions to apply when troubleshooting.  
 For each failure, a list of the possible causes and pertaining operations is given.

## Engine

### Poor performance

#### POOR PERFORMANCE

Possible Cause	Operation
Fuel pump	Check the injection load relay
Excess of scales in the combustion chamber	Descale the cylinder, the piston, the head and the valves
Incorrect timing or worn timing system elements	Time the system again or replace the worn parts
Silencer obstructed	Replace
Air filter blocked or dirty.	Remove the sponge, wash with water and car shampoo, then soak it in a mixture of 50% petrol and 50% specific oil. Press with your hand without squeezing, allow it to drip dry and refit.
Oil level exceeds maximum	Check for causes and fill to reach the correct level
Lack of compression: parts, cylinder and valves worn	Replace the worn parts
Drive belt worn	Replace
Inefficient automatic transmission	Check the rollers, the pulley movement and make sure the drive belt is in good conditions; replace the damaged parts and lubricate the moveable driven pulley with specific grease.
Clutch slipping	Check the clutch system and/or the bell and replace if necessary
Overheated valves	Remove the head and the valves, grind or replace the valves
Wrong valve adjustment	Adjust the valve clearance properly
Valve seat distorted	Replace the head unit

### Starting difficulties

#### DIFFICULT STARTING

Possible Cause	Operation
Rpm too low at start-up or engine and start-up system damaged	Check the starter motor, the system and the torque limiter
Incorrect valve sealing or valve adjustment	Inspect the head and/or restore the correct clearance
Engine flooded	Try starting-up with the throttle fully open. If the engine fails to start, remove the spark plug, dry it and before refitting, make the engine turn so as to expel the fuel excess taking care to connect the cap to the spark plug, and this in turn to the ground. If the fuel tank is empty, refuel and start up.
Air filter blocked or dirty.	Remove the sponge, wash with water and car shampoo, then soak it in a mixture of 50% petrol and 50% specific oil. Press with your hand without squeezing, allow it to drip dry and refit.
Faulty spark plug or incorrect ignition advance	Replace the spark plug or check the ignition circuit components
Flat battery	Check the charge of the battery, if there are any sulphur marks, replace and use the new battery following the instructions shown in the chapter
Intake coupling cracked or clamps incorrectly tightened	Replace the intake coupling and check the clamps are tightened

### Excessive oil consumption/Exhaust smoke

#### EXCESSIVE CONSUMPTION

Possible Cause	Operation
Wrong valve adjustment	Adjust the valve clearance properly
Overheated valves	Remove the head and the valves, grind or replace the valves

Possible Cause	Operation
Misshapen/worn valve seats	Replace the head unit
Worn cylinder, Worn or broken piston rings	Replace the piston cylinder assembly or piston rings
Worn or broken piston rings or piston rings that have not been fitted properly	Replace the piston cylinder unit or just the piston rings
Oil leaks from the couplings or from the gaskets	Check and replace the gaskets or restore the coupling seal
Worn valve oil seal	Replace the valve oil seal
Worn valve guides	Check and replace the head unit if required

## Insufficient lubrication pressure

### POOR LUBRICATION PRESSURE

Possible Cause	Operation
By-Pass remains open	Check the By-Pass and replace if required. Carefully clean the By-Pass area.
Oil pump with excessive clearance	Perform the dimensional checks on the oil pump components
Oil filter too dirty	Replace the cartridge filter
Oil level too low	Restore the level adding the recommended oil type

## Transmission and brakes

## Clutch grabbing or performing inadequately

### IRREGULAR CLUTCH PERFORMANCE OR SLIPPAGE

Possible Cause	Operation
Faulty clutch	Check that there is no grease on the masses. Check that the clutch mass faying surface with the bell is mainly in the centre with equivalent characteristics on the three masses. Check that the clutch casing is not scored or worn in an anomalous way

## Insufficient braking

### INEFFICIENT BRAKING SYSTEM

Possible Cause	Operation
Inefficient braking system	Check the pad wear (1.5 min). Check that the brake discs are not worn, scored or warped. Check the correct level of fluid in the pumps and change brake fluid if necessary. Check there is no air in the circuits; if necessary, bleed the air. Check that the front brake calliper moves in axis with the disc.
Fluid leakage in hydraulic braking system Brake disc slack or distorted	Failing elastic fittings, plunger or brake pump seals, replace Check the brake disc screws are locked; measure the axial shift of the disc with a dial gauge and with wheel mounted on the vehicle.

## Brakes overheating

### BRAKE OVERHEAT

Possible Cause	Operation
Defective plunger sliding	Replace the calliper.
Brake disc slack or distorted	Check the brake disc screws are locked; use a dial gauge and a wheel mounted on the vehicle to measure the axial shift of the disc.
Clogged compensation holes on the pump Swollen or stuck rubber gaskets	Clean carefully and blast with compressed air Replace the calliper.

**Steering and suspensions**

**Heavy steering**

**STEERING HARDENING**

Possible Cause	Operation
Steering hardening	Check the tightening of the top and bottom ring nuts. If irregularities continue in turning the steering even after making the above adjustments, check the rotation seats and the steering fifth wheels.

**Excessive steering play**

**EXCESSIVE STEERING CLEARANCE**

Possible Cause	Operation
Torque not conforming	Check the tightening of the top and bottom ring nuts. If irregularities continue in turning the steering even after making the above adjustments, check the rotation seats and the steering fifth wheels.

**Noisy suspension**

**NOISY SUSPENSION**

Possible Cause	Operation
Malfunctions in the suspension system	If the front suspension is noisy, check: tightening torques, headstock components, inspect forks.

**Suspension oil leakage**

**OIL LEAKAGE FROM SUSPENSION**

Possible Cause	Operation
Faulty or broken seals	Replace the shock absorber

## INDEX OF TOPICS

ELECTRICAL SYSTEM

ELE SYS

---

**Components arrangement**

**1.** Starter switch: remove the legshield to reach them.

**2.** Immobilizer antenna: remove the legshield to reach them.

**3.** Regulator connector: remove the legshield to reach them.

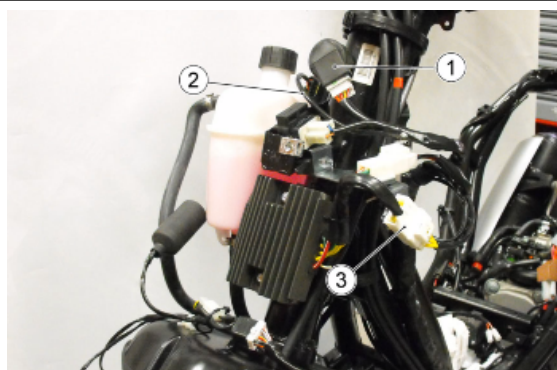

**4.** Spark plug: remove the spark plug inspection cover to access the spark plug.

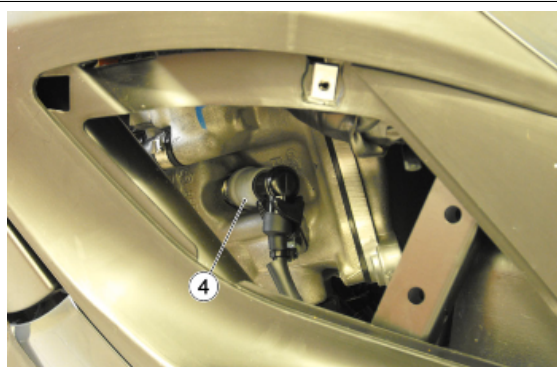



**5. Battery:** lift the saddle and remove the battery cover to access the battery.

**6. Fuses:** lift the saddle and remove the battery cover to access the battery.

**7. Solenoids:** lift the saddle and remove the battery cover to access the battery.

**8. Diagnostic socket:** lift the saddle and remove the battery cover to access the battery.

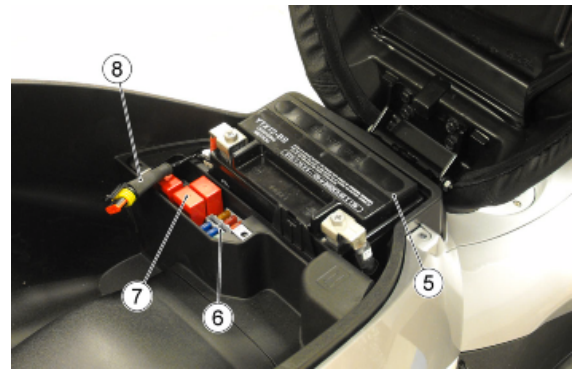

**9. ECU:** lift the saddle and remove the engine inspection cover to access the ECU.



**10. Saddle actuator:** to reach it, remove the left fairing.

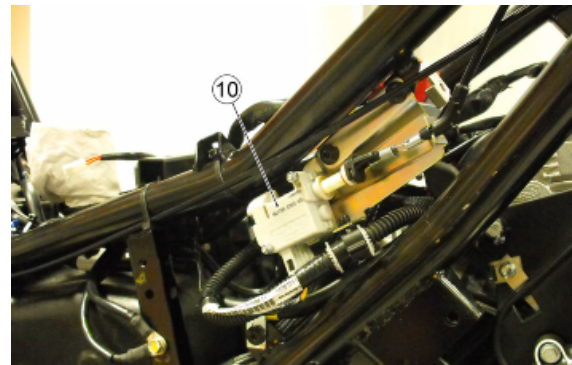

**11. HV coil:** remove the helmet compartment to reach it.



**12.** Start-up solenoid: to reach it, remove the left fairing.

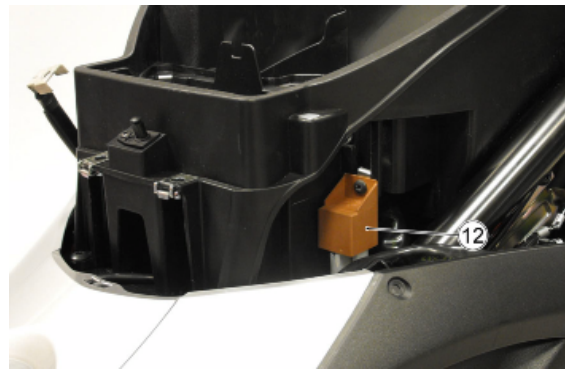

**13.** Stand button: remove the left footrest to reach it.

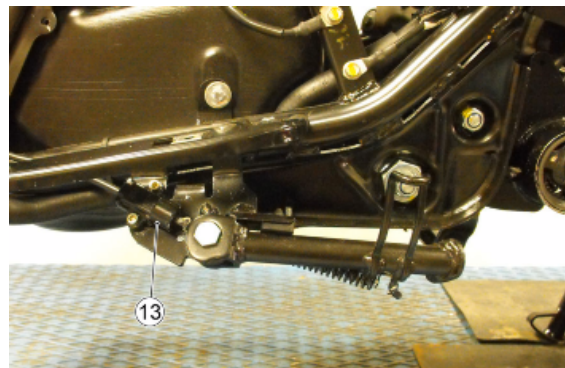

**14.** Stator connector: remove the central chassis cover to reach them.

**15.** Fall sensor: remove the central chassis cover to reach them.

**16.** Fuel pump: remove the central chassis cover to reach them.

**17.** Fuel level transmitter: remove the central chassis cover to reach them.

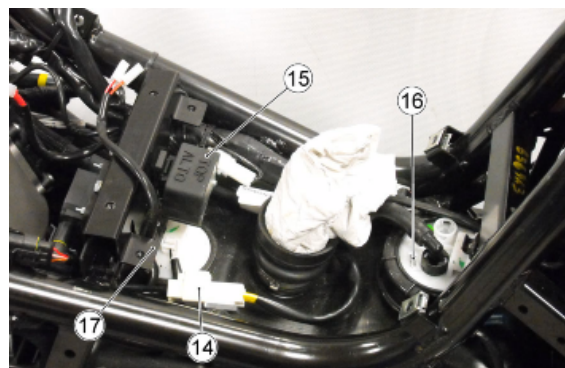

**18.** Horn: remove the front wheel housing to reach it.

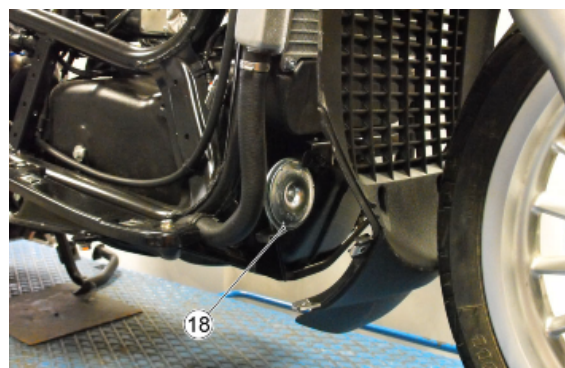

**19.** Temperature sensor: remove the legshield to reach them.

**20.** LV socket: remove the legshield to reach them.

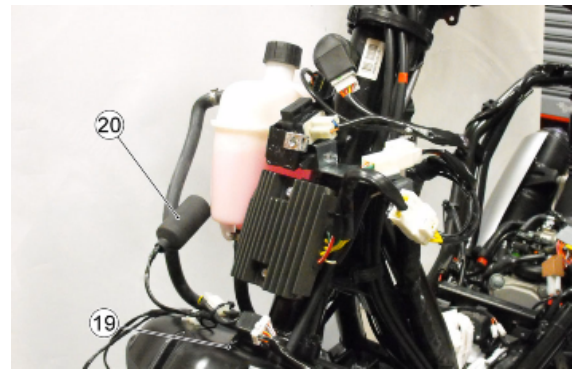

**21.** Regulator: remove the legshield to reach them.

**22.** Turn indicator device: remove the legshield to reach them.

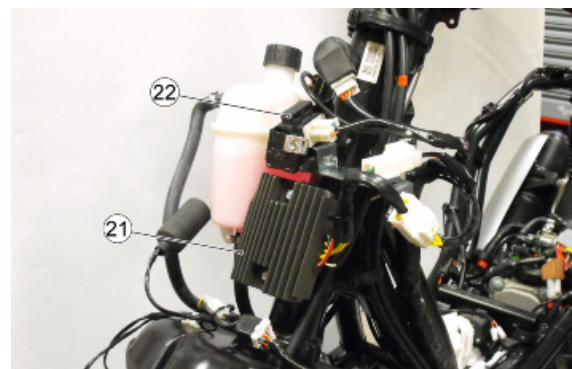

**Instrument panel**

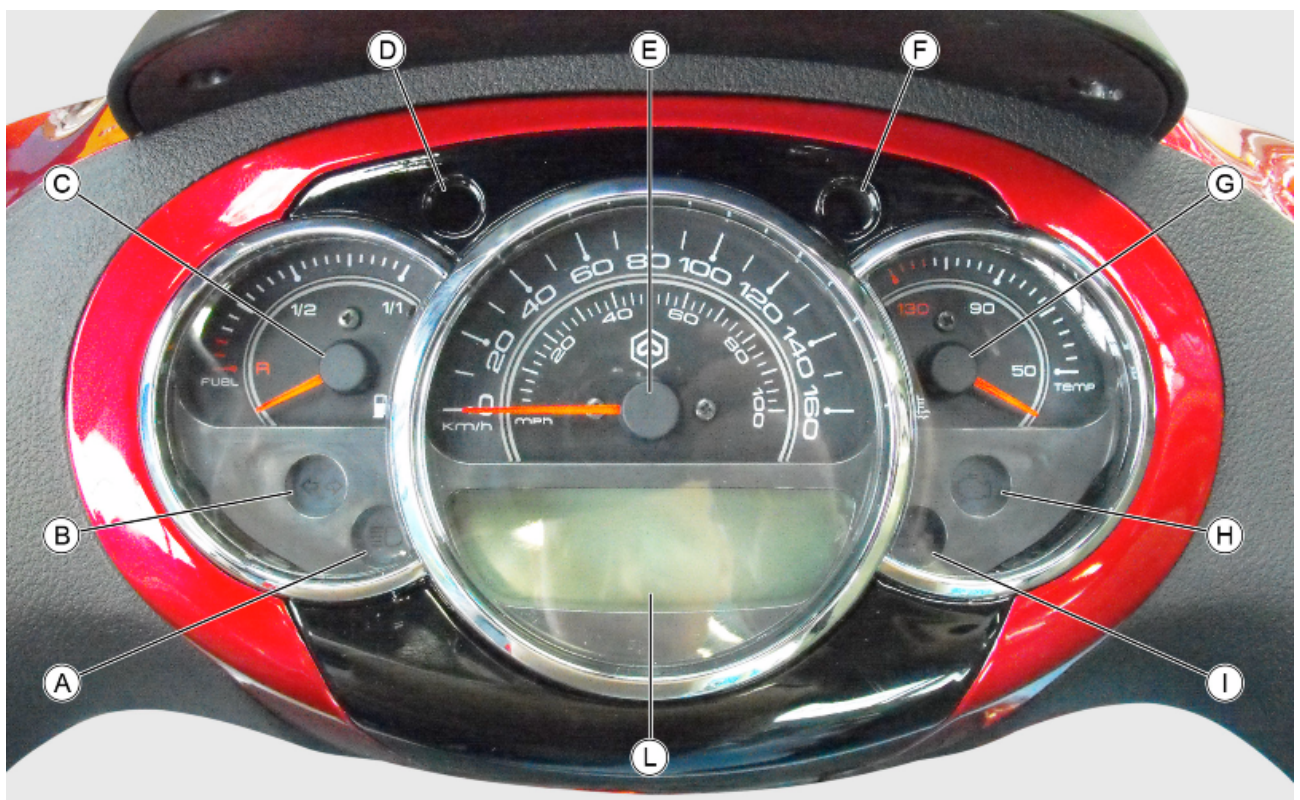

- A=** High beam warning light
- B =** Turn indicator warning lights
- C =** Fuel gauge

- D = Low fuel warning light
- E = Speedometer
- F = Immobiliser LED
- G = Coolant temperature gauge
- H = Engine control telltale light
- I = Engine oil pressure warning light
- L = Digital display

---

## Ground points

- Frame ground points «A» and «B». Remove the left footrest to reach them.
- Engine ground point «C»

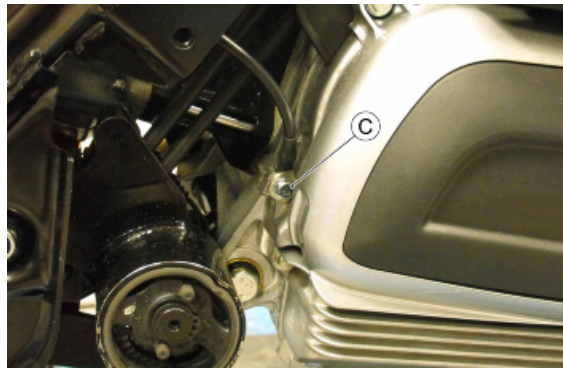
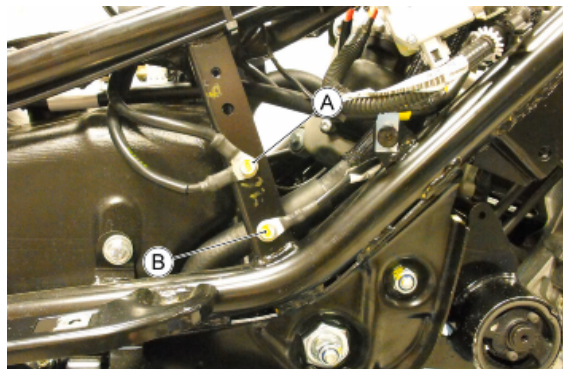

---

## Electrical system installation

---

## Front side

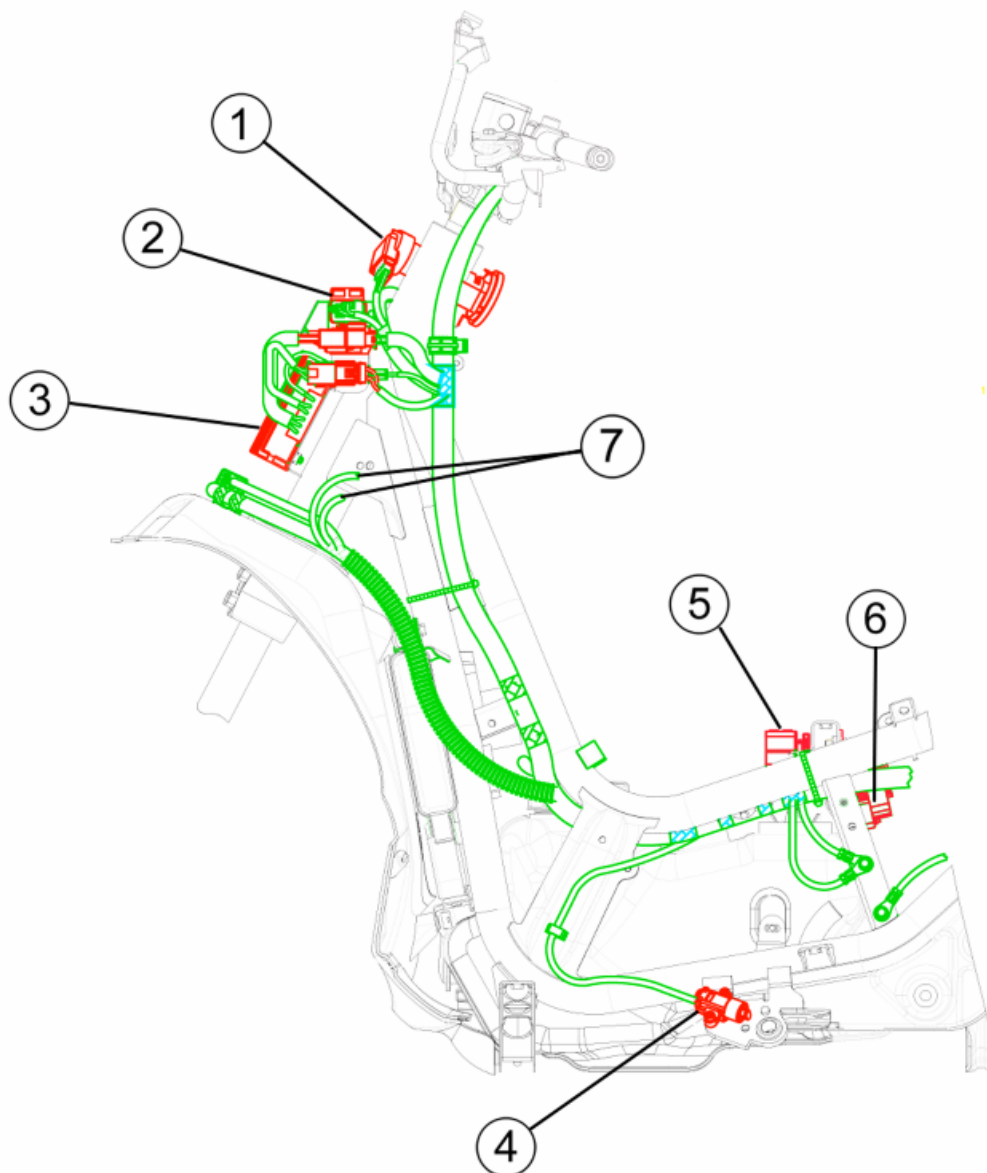

1. Ignition switch hood
2. Turn indicator control device
3. Voltage regulator
4. Side stand switch
5. Overturn sensor
6. HV coil
7. Front L turn indicator and daylight running lights

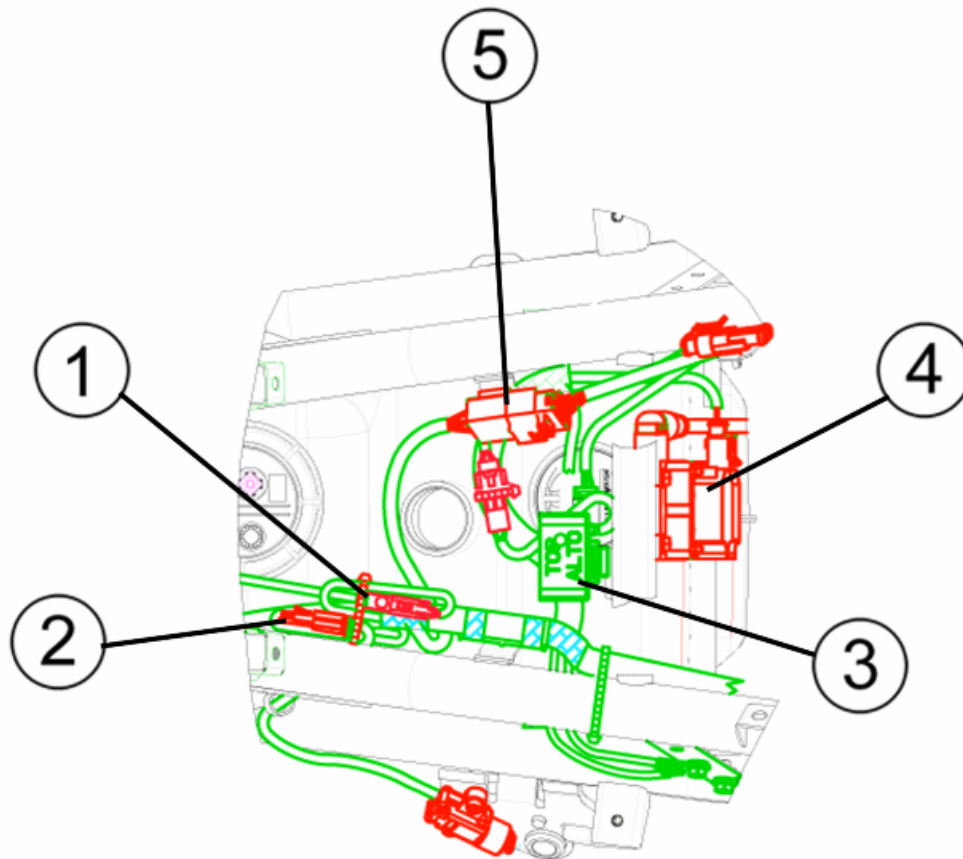

1. Electric fan connection
2. Side stand connection
3. Overturn sensor
4. HV coil
5. Stator connection

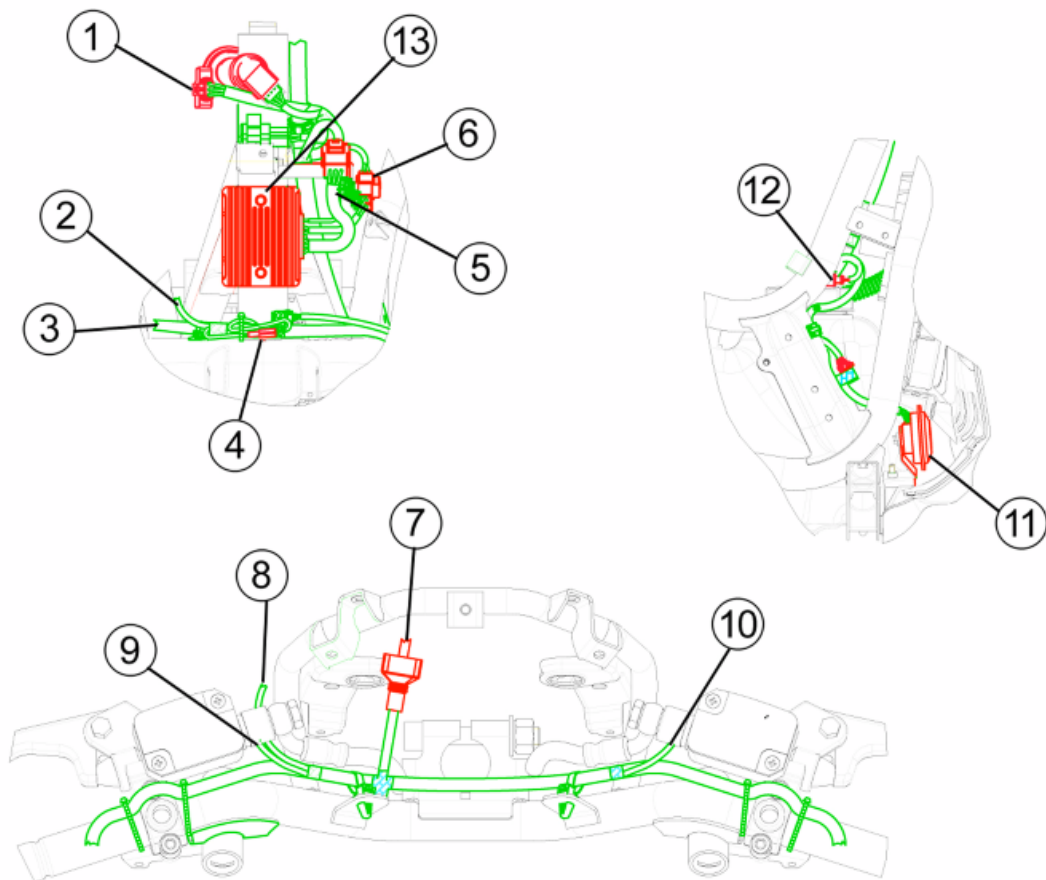

1. Immobilizer aerial
2. Low voltage power socket accessories in the front top box
3. To the front right turn indicator and daylight running lights
4. External air temperature sensor
5. Boost cable connection (only in version 125)
6. Flywheel - regulator connection
7. To instrument panel
8. To headlight
9. To the left stop button
10. to the right stop button
11. Horn
12. Fuel pump connection
13. Voltage regulator

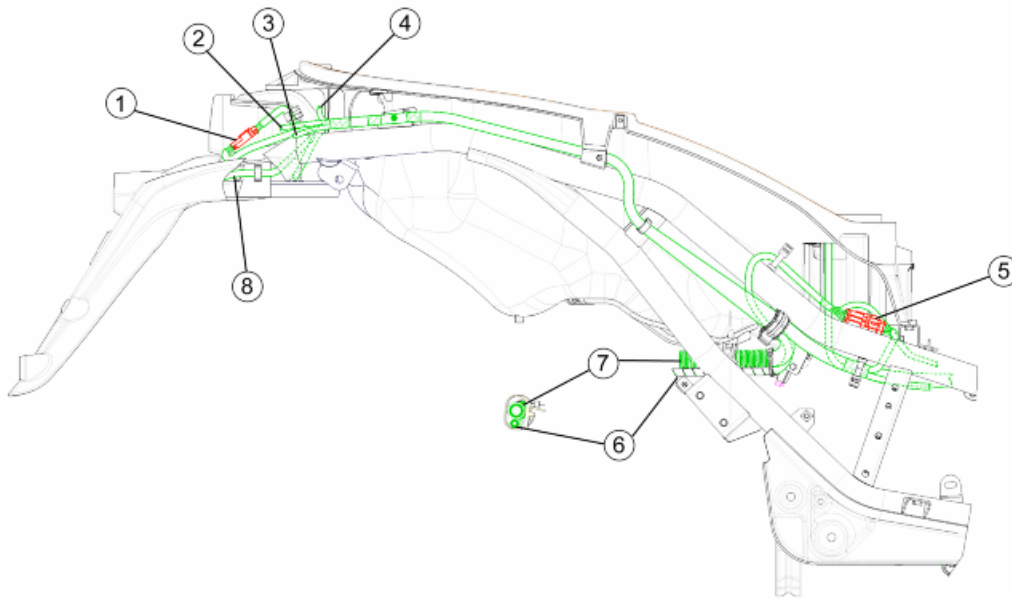
**Back side**

1. License plate light connection
2. To the right headlamp
3. To the right turn indicator
4. Helmet compartment lighting to the light unit
5. Pick-up connection
6. Flywheel cables
7. Cables to the motor
8. To the license plate lightening



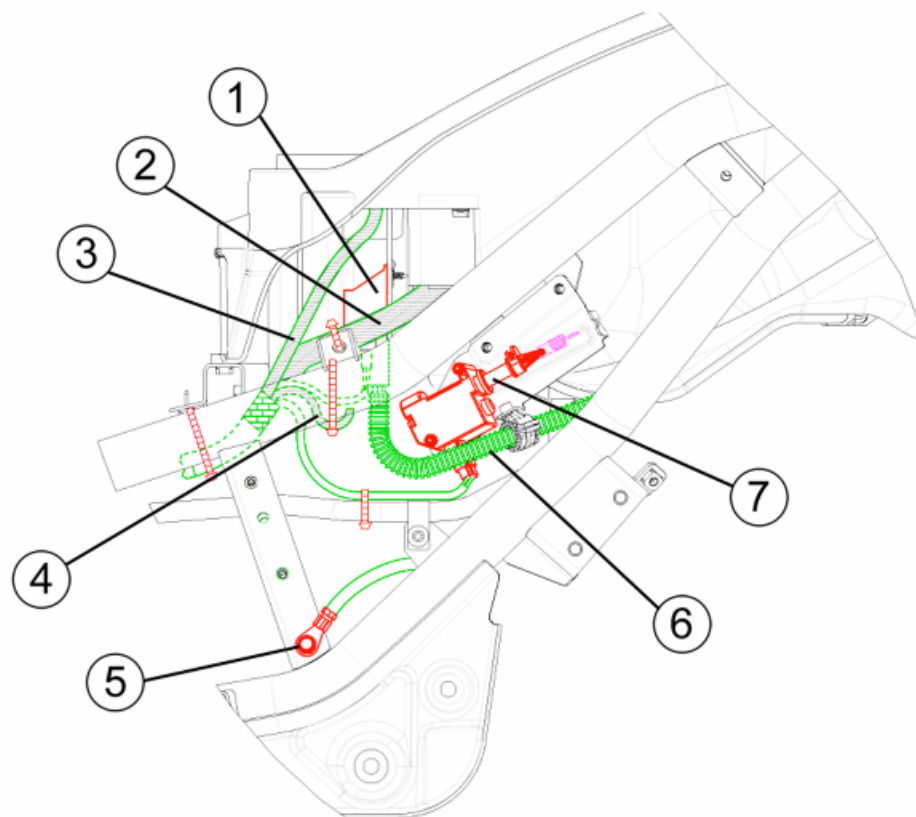

1. Starter relay
2. To the fuse holder terminal block
3. To battery positive
4. To the starter relay
5. Ground point
6. Starter motor positive cable
7. Saddle opening actuator

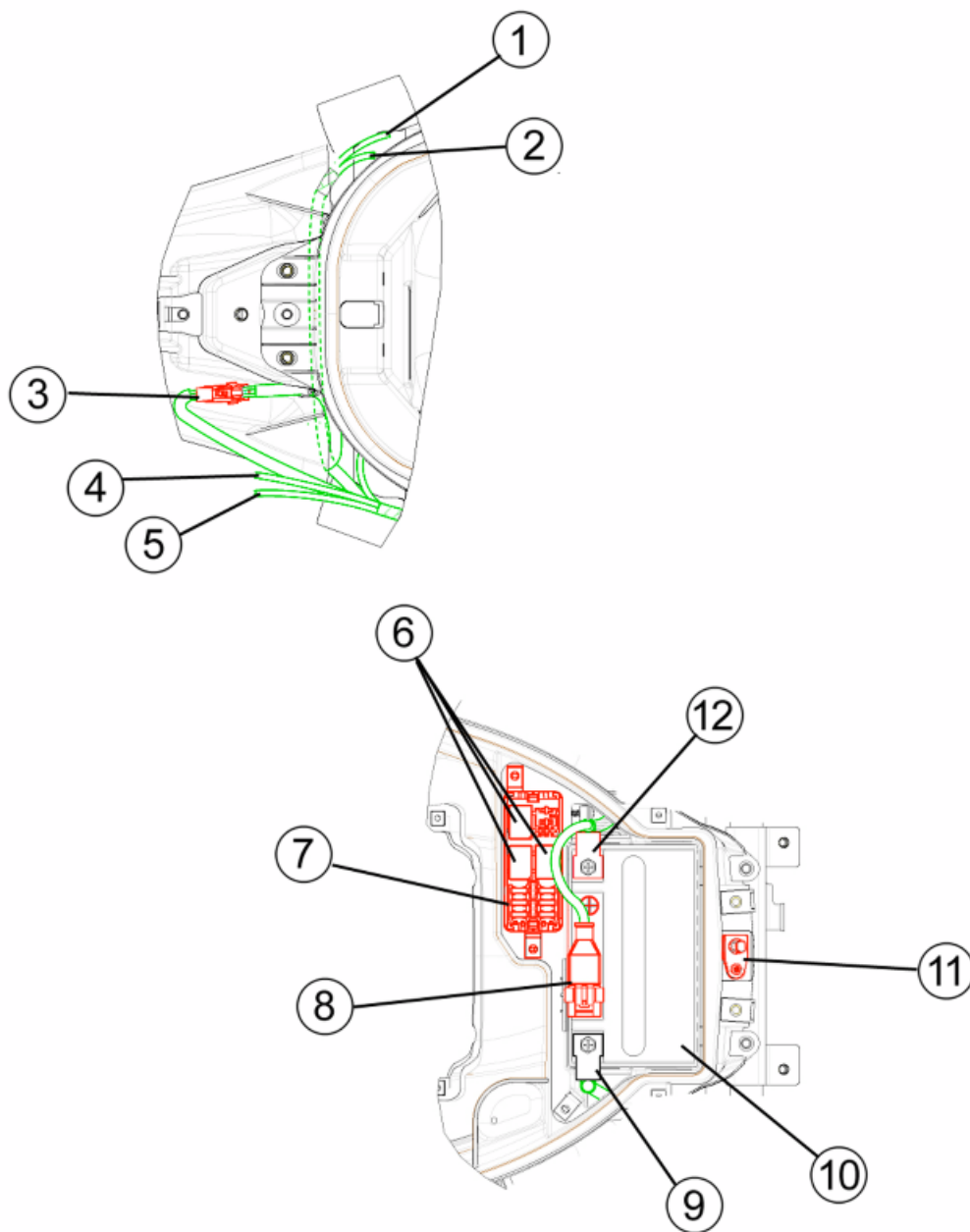

1. To the left turn indicator
2. To the left headlamp
3. License plate light connection
4. To the right turn indicator
5. To the right headlamp
6. Micro-relay
7. Rear fuse-box

8. Diagnostics socket
9. Negative battery pole
10. Battery 12V 10Ah
11. Helmet compartment light switch
12. Positive battery pole

---

## Conceptual diagrams

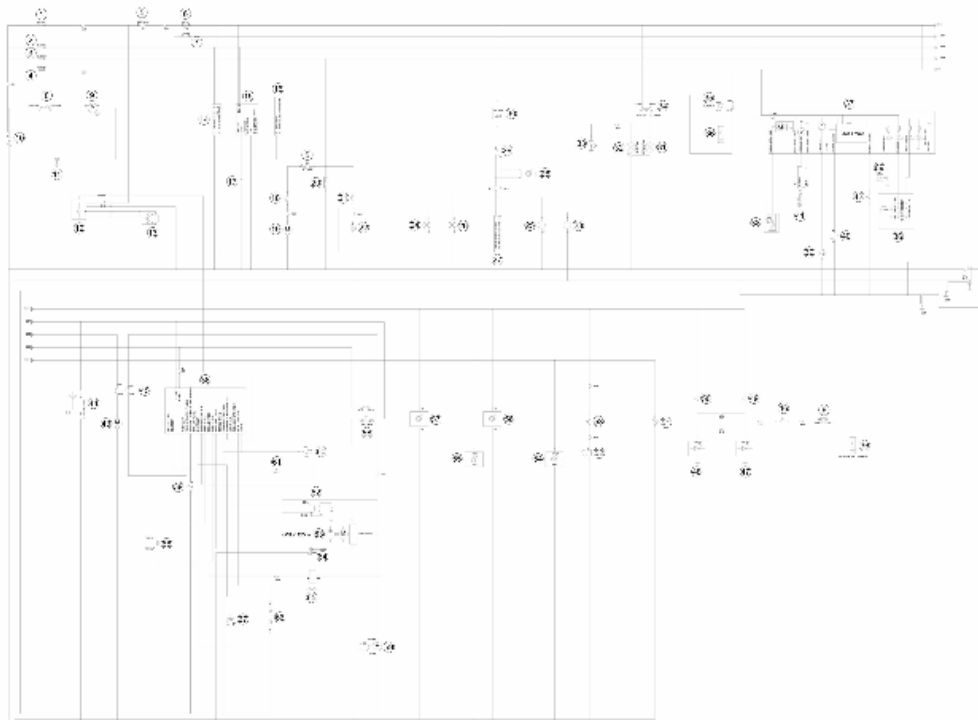

### BASIC CIRCUIT DIAGRAM LEGEND:

1. F01-30A
2. F02-15A
3. F03-10A
4. F04-15A
5. Starter switch
6. F05-10A
7. F06-5A
8. Starter solenoid
9. Starter motor
10. 12V - 10Ah Battery
11. Chassis ground
12. Regulator

13. Flywheel
14. Antitheft
15. Provision for actuator control receiver
16. Antitheft
17. Reset receiver radio
18. Saddle button
19. Actuator
20. LV socket
21. Helmet compartment light button
22. Light unit
23. Rear right turn indicator
24. Rear left turn indicator
25. Front right hand turn indicator
26. Front left hand turn indicator
27. Antitheft
28. Turn indicator warning light
29. Turn indicator switch
30. turn indicator control
31. Low beam light bulb
32. High beam light bulb
33. High beam indicator light
34. Light switch
35. Headlight solenoid
36. Electronic control unit
37. Instrument panel
38. Fuel gauge
39. Engine temperature sensor
40. Ambient temperature sensor
41. Speed sensor
42. Mode button
43. Electric fan
44. Immobilizer aerial
45. Electric fan solenoid
46. Starter button
47. Right hand stop light bulb
48. Left hand stop light bulb
49. Stop button
50. Stop button

- 51. License plate lighting bulb
  - 52. Horn
  - 53. Horn button
  - 54. Rear right hand turn indicator bulb
  - 55. Rear left hand turn indicator bulb
  - 56. Front right hand turn indicator bulb
  - 57. Front left hand turn indicator bulb
  - 58. Injection load solenoid
  - 59. Fuel pump
  - 60. Engine stop switch
  - 61. Stand button (raised position)
  - 62. HV coil
  - 63. Water pump (125ie version only)
  - 64. Diagnostics socket
  - 65. Fuel injector
  - 66. Overturn sensor
  - 67. Lambda probe
  - 68. Pickup
  - 69. Oil pressure sensor
-

## Ignition

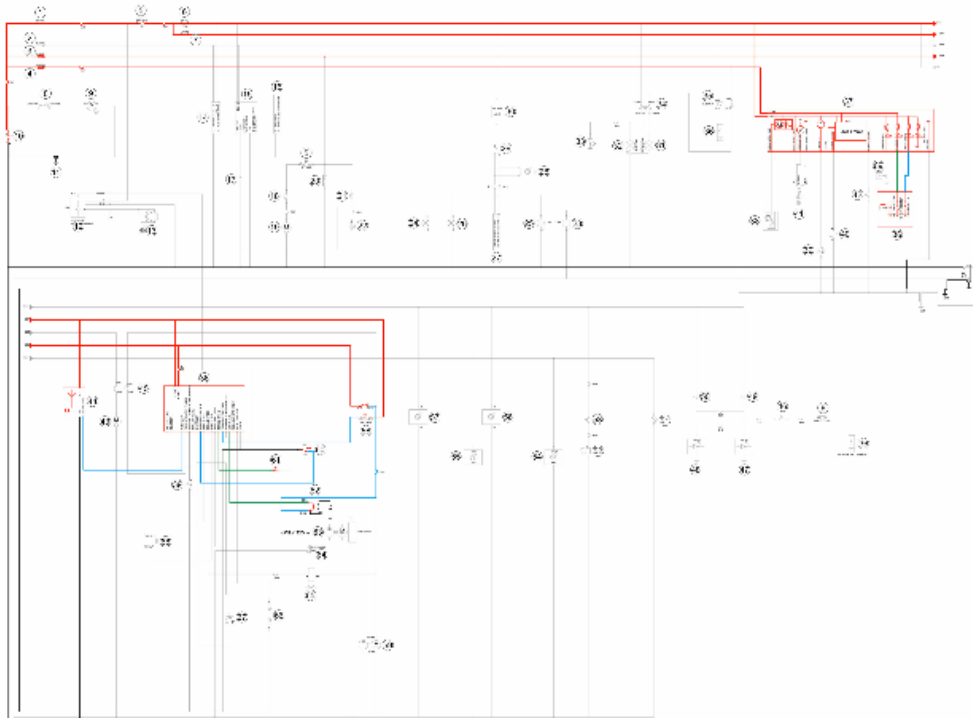

### BASIC CIRCUIT DIAGRAM LEGEND:

1. F01-30A
3. F03-10A
- 4.F04-15A
- 5.Starter switch
- 6.F05-10A
- 7.F06-5A
- 10.12V - 10Ah Battery
- 11.Chassis ground
- 36.Electronic control unit
- 37.Instrument panel
- 43.Electric fan
- 58.Injection load solenoid
- 60.Engine stop switch
- 61.Stand button (raised position)
- 62.HV coil

## Battery recharge and starting

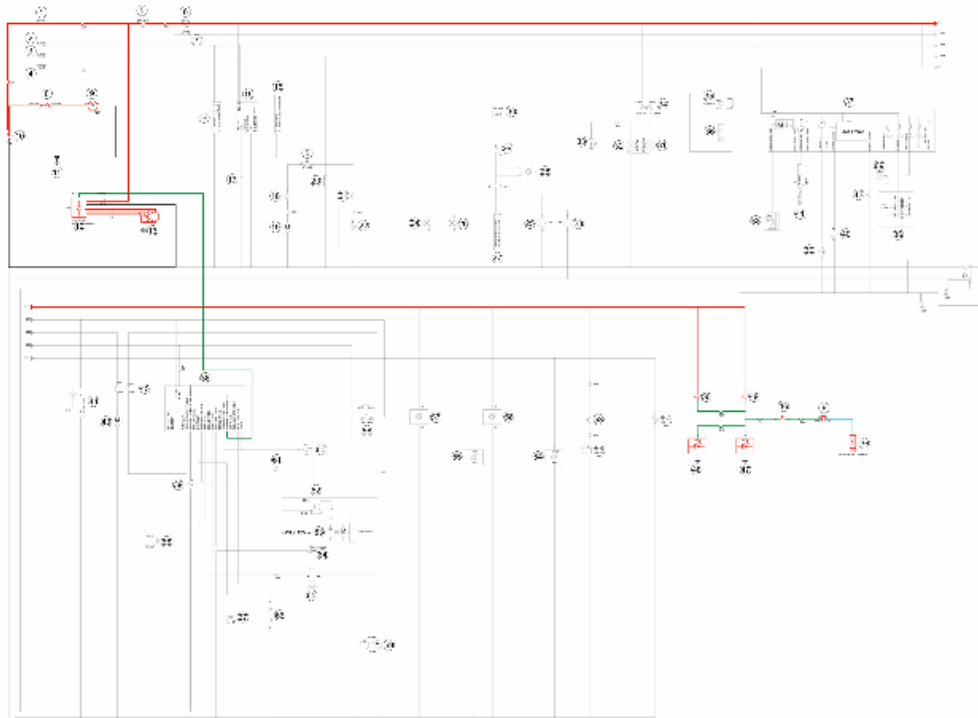

### BASIC CIRCUIT DIAGRAM LEGEND:

- 1. F01-30A
- 5. Starter switch
- 6. F05-10A
- 8. Starter solenoid
- 9. Starter motor
- 10. 12V - 10Ah Battery
- 11. Chassis ground
- 12. Regulator
- 13. Flywheel
- 36. Electronic control unit
- 46. Starter button
- 47. Right stop light bulb
- 48. Left stop light bulb
- 49. Stop button
- 50. Stop button

## Level indicators and enable signals section

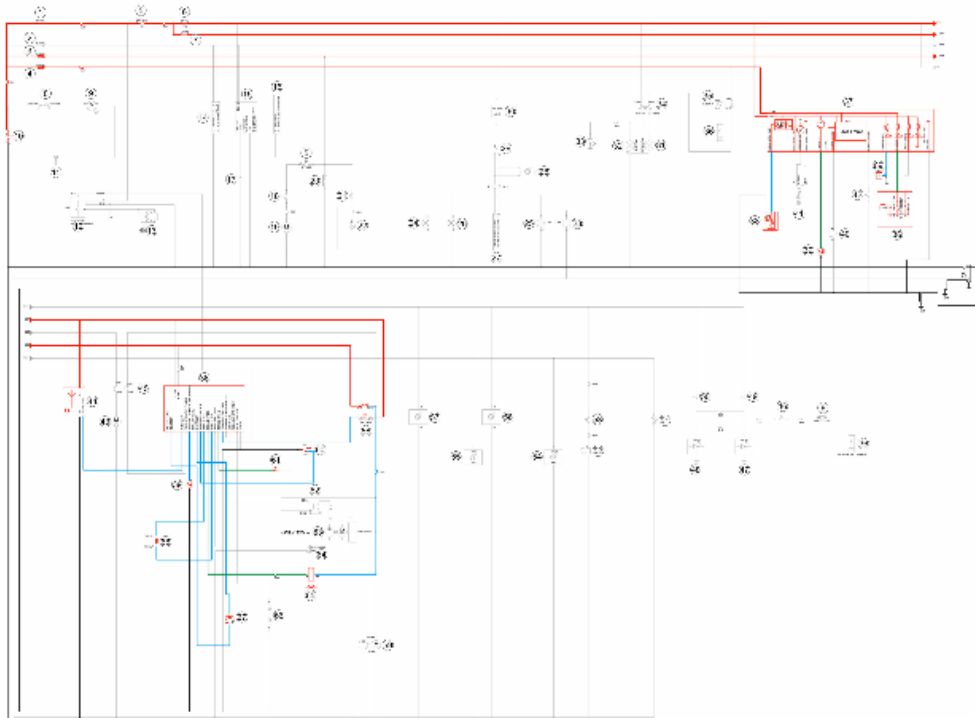

### BASIC CIRCUIT DIAGRAM LEGEND:

1. F01-30A
- 2.F02-15A
3. F03-10A
- 4.F04-15A
- 5.Starter switch
- 6.F05-10A
- 7.F06-5A
- 10.12V - 10Ah Battery
- 36.Electronic control unit
- 37.Instrument panel
- 38.Fuel gauge
- 39.Engine temperature sensor
- 44.Immobilizer aerial
- 58.Injection load solenoid
- 60.Engine stop switch
- 61.Stand button (raised position)
- 65.Fuel injector



67.Lambda probe

68.Pickup

69.Oil pressure sensor

## Devices and accessories

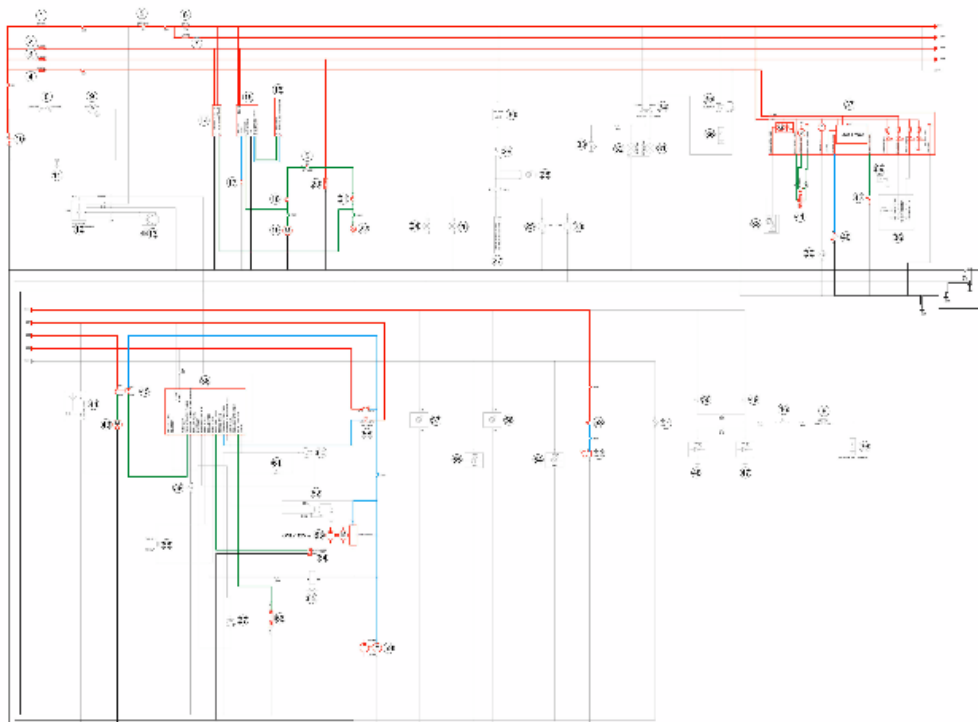

### BASIC CIRCUIT DIAGRAM LEGEND:

1. F01-30A
- 2.F02-15A
3. F03-10A
- 4.F04-15A
- 5.Starter switch
- 6.F05-10A
- 7.F06-5A
- 10.12V - 10Ah Battery
14. Antitheft
15. Provision for actuator control receiver
- 16.Antitheft
- 17.Reset receiver radio
- 18.Saddle button
- 19.Actuator

- 20.LV socket
- 21.Helmet compartment light button
- 22.Light unit
- 37.Instrument panel
- 40.Ambient temperature sensor
- 41.Speed sensor
- 42.Mode button
- 43.Electric fan
- 45.Electric fan solenoid
- 52.Horn
- 53.Horn button
- 58.Injection load solenoid
- 59.Fuel pump
- 63.Water pump (125ie version only)
- 64.Diagnostics socket
- 66.Overturn sensor

---

## Lights and turn indicators

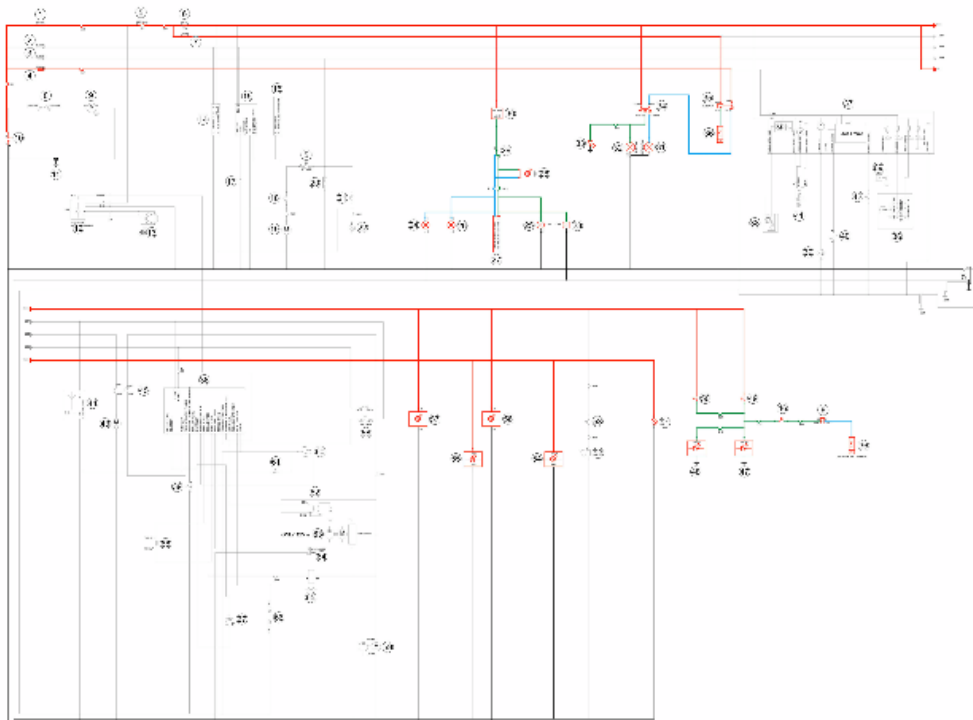

### BASIC CIRCUIT DIAGRAM LEGEND:

- 1. F01-30A

- 4.F04-15A
- 5.Starter switch
- 6.F05-10A
- 7.F06-5A
- 10.12V - 10Ah Battery
- 11.Chassis ground
- 23.Rear right turn indicator
- 24.Rear left turn indicator
- 25.Front right turn indicator
- 26.Front left turn indicator
- 27.Antitheft
- 28.Turn indicator warning light
- 29.Turn indicator switch
- 30. turn indicator control
- 31.Low beam light bulb
- 32.High beam light bulb
- 33.High beam warning light
- 34.Light switch
- 35.Headlight solenoid
- 36.Electronic control unit
- 46.Starter button
- 47.Right stop light bulb
- 48.Left stop light bulb
- 49.Stop button
- 50.Stop button
- 51.License plate lighting bulb
- 54.Rear right turn indicator bulb
- 55.Rear left turn indicator bulb
- 56.Front right turn indicator bulb
- 57.Front left turn indicator bulb

---

## **Checks and inspections**

This section is dedicated to the checks on the electrical system components.

---

## **Immobiliser**

The electronic ignition system is controlled by the control unit with the integrated Immobilizer system. The immobilizer is an anti-theft system that allows the vehicle to be operated only when it is started with coded keys recognised by the control unit. The code is integrated in a transponder in the key block.

This allows the driver clear operation without having to do anything other than just turning the key. The Immobilizer system consists of the following components:

- an electronic control unit
- immobilizer aerial
- master key with built-in transponder
- service key with built-in transponder
- diagnosis LED

The diagnosis LED also works as a theft-deterrent blinker. This function is activated every time the key switch is set to «OFF» or the engine emergency cut-off switch is set to «OFF». It remains activated for 48 hours in order not to affect the battery charge. When the ignition switch is turned to «ON», the deterring blinker function is deactivated. Subsequently, a flash confirms the switching to «ON». The duration of the flash depends on the programming of the electronic control unit. If the LED is off regardless of the position of the ignition-key switch and/or the instrument panel is not initiated, check if:

- there is battery voltage
- fuses No. 1; 2; 6 and 9 are in working order
- there is power to the control unit as specified below:

### 2 With the key switch set to OFF:

- if there is battery voltage between terminals 6-26 and terminal 6-chassis ground (fixed power supply). If there is no voltage, check that fuse 6 and its cable harness are in working order.

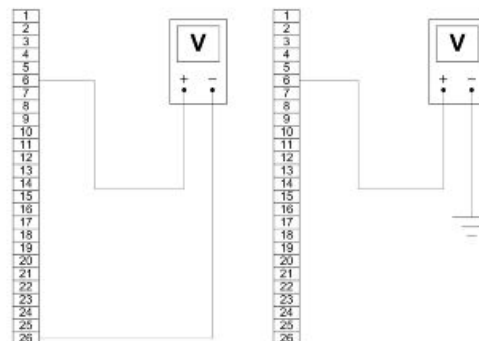

### With the key switch in the OFF position:

- if there is battery voltage between terminals 5-26 and terminals 5-chassis ground (fixed power supply). If there is no voltage, check the key switch contacts, and that fuses No. 1 and 9 and their cable harnesses are in working order.

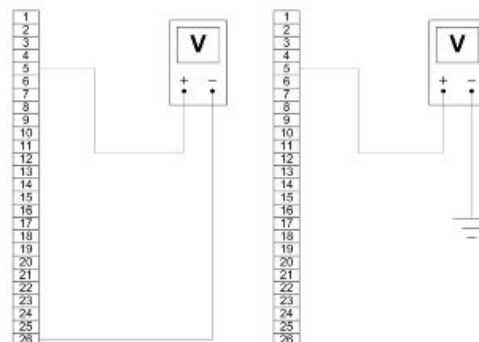

- There is continuity between terminals 12-18 and the emergency cut-off switch is set to «RUN» and the side stand is folded up. If there is no continuity, check the contacts of the latter.

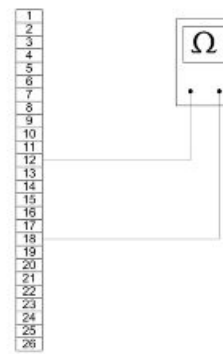

After removing the leg shield back plate, remove the electrical connection from the aerial as shown in the picture.



Remove the protective base from the connector.



With the ignition key switch at «ON» check if there is battery voltage between the Red-White and Black cables

With MIU connector disconnected, check the continuity between the Orange-White cable and pin 7 of the interface wiring.

**Specific tooling**

**020481Y Control unit interface wiring**

**020331Y Digital multimeter**

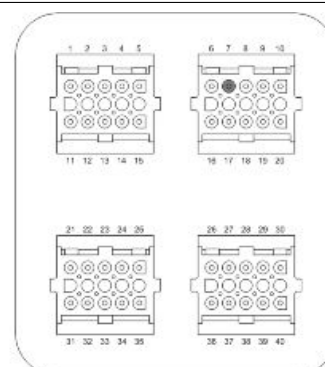

## Virgin circuit

When the ignition system is not encrypted, any key will start the engine but limited to 2000 rpm. The keys can only be recognised if the control unit has been programmed properly. The data storage procedure for a previously not programmed control unit provides for the recognition of the Master as the first key to be stored to memory: this becomes particularly important because it is the only key that enables the control unit to be wiped clean and reprogrammed for the memorisation of the service keys. The Master and service keys must be used to code the system as follows:

- Insert the Master key, turn it to «ON» and keep this position for two seconds (limit values 1 to 3 seconds).
- Insert the service key and turn it to «ON» for 2 seconds.
- If you have copies of the key, repeat the operation with each key.
- Insert the MASTER key again and turn it to «ON» for 2 seconds.

The maximum time to change keys is 10 seconds.

A maximum of 7 service keys can be programmed at one time.

It is essential to adhere to the times and the procedure. If you do not, start again from the beginning.

Once the system has been programmed, the Master key transponder is strictly matched with the control unit. With this link established, it is now possible to encode new service keys, in the event of losses, replacements, etc. Each new programming deletes the previous one; to add or delete a key it is therefore necessary to repeat the procedure using all the keys that you intend to keep in use. If a service key becomes uncoded, the efficiency of the high voltage circuit shielding must be thoroughly inspected: In any case it is advisable to use resistive spark plugs.

## Diagnostic codes

The Immobilizer system is tested each time the key switch is turned from «OFF» to «ON». During this diagnosis phase a number of control unit statuses can be identified and various light codes displayed. Regardless of the code transmitted, if at the end of the diagnosis the LED remains off permanently, the ignition is enabled. If, however, the LED remains on permanently, it means the ignition is inhibited:

**1. Previously unused control unit - key inserted:** a single 2 second flash is displayed, after which the LED remains off permanently. The keys can be stored to memory, the vehicle can be star-

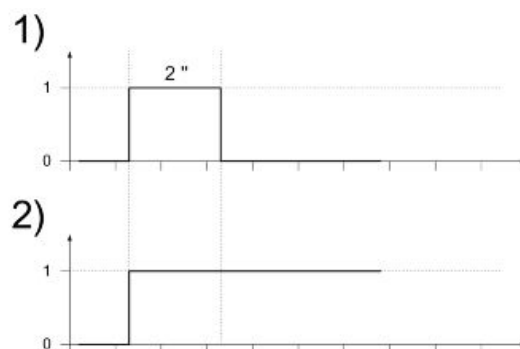

ted but with a limitation imposed on the number of revs.

**2. Previously unused control unit - transponder absent or cannot be used:** The LED is permanently ON; in this condition, no operations are possible, including starting of the vehicle.

**3. Programmed control unit - the service key in (normal condition of use):** a single 0.7-second flash is displayed, after which the LED remains off steadily. The engine can be started.

**4. Programmed control unit - Master key in:** a 0.7-sec flash is displayed followed by the LED remaining off for 2 sec and then by short 0.46-sec flashes, the same number of times as there are keys stored in the memory including the Master key. When the diagnosis has been completed, the LED remains permanently OFF. The engine can be started.

**5. Programmed control unit - fault detected:** a light code is displayed according to the fault detected, after which the LED remains on steadily. The engine cannot be started. The codes that can be transmitted are:

- 1-flash code
- 2-flash code
- 3-flash code

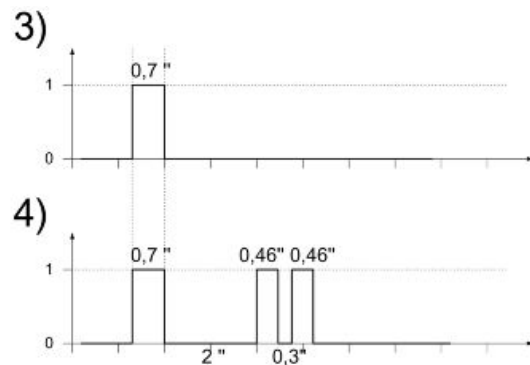

## Diagnostic code - 1 flash

A one-flash code indicates a system where the serial line is not present or is not detected. Check the Immobilizer aerial wiring and change it if necessary.

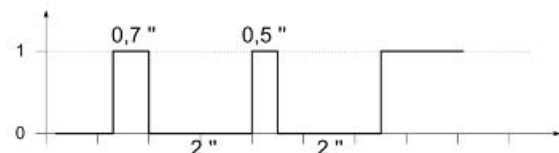

## Diagnostic code - 2 flashes

A two-flash code shows a system where the control unit does not show the transponder signal. This might depend on the inefficiency of the immobiliser aerial or the transponder.

Turn the switch to «ON» using several keys: if the code is repeated even with the Master key, check the aerial wiring and change it if necessary. If this is not the case, replace the defective key and/or reprogram the control unit.

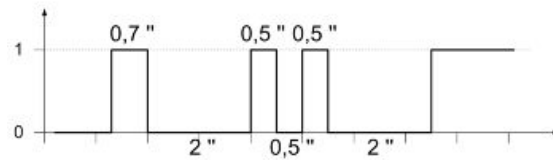

## Diagnostic code - 3 flashes

A three-flash code indicates a system where the control unit does not recognise the key. Turn the switch to «ON» using several keys: if the error code is repeated even with the Master key, replace the control unit. If this is not the case, reprogram the decoder.

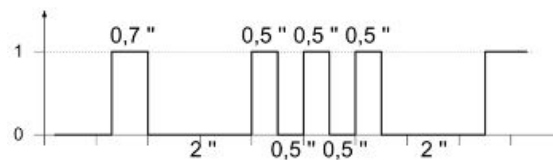

## Ignition circuit

### No spark plug

#### WARNING

**ALL CONTINUITY TESTS MUST BE CARRIED OUT WITH THE CORRESPONDING CONNECTORS DISCONNECTED.**

#### HV coil primary resistance value:

Disconnect the connector of the HV coil and measure the resistance between the two terminals.

#### Characteristic

#### HV coil resistance primary value:

~ 0.9  $\Omega$

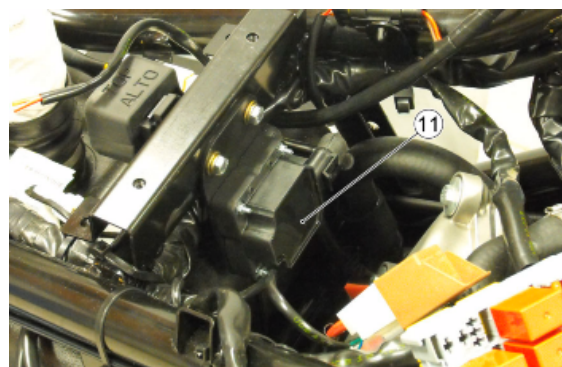



**HV coil secondary resistance value:**

- 1) Disconnect the HV cable from the spark plug and measure the resistance between the spark plug cap and the HV coil negative terminal.
- 2) Disconnect the spark plug cap from the HV cable and measure the resistance between the HV cable end and the HV coil negative terminal (see figure).
- 3) Measure the resistance between the 2 ends of the spark plug cap.

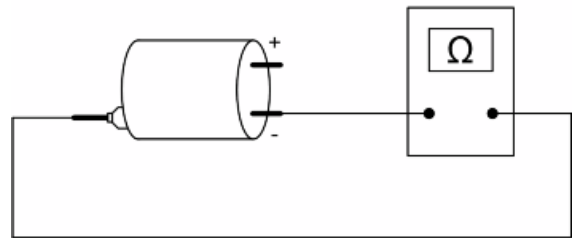
**Characteristic****HV coil secondary resistance value with spark plug cap**

~ 8.4 kΩ

**HV coil secondary resistance value:**

~ 3.4 kΩ

**Spark plug cap resistance value**

~ 5 kΩ

**Battery recharge circuit**

The charging circuit consists of three-phase alternator and a permanent magneto flywheel.

The generator is directly connected to the voltage regulator.

This, in its turn, is connected directly to the ground and the battery positive terminal passing through the 30A protective fuse.

The three-phase alternator provides good recharge power and at low revs a good compromise is achieved between generated power and idle stability.

**Remote controls check**

To check the operation of a solenoid:

- 1) Check that, given regular conditions, there is no continuity between terminals 87 and 30.
- 2) Apply a 12V voltage to power terminals 86 and 85 of the solenoid.
- 3) With the solenoid fed, check that there is continuity between terminals 87 and 30.
- 4) If these conditions are not met, the solenoid is surely damaged and, therefore, it should be replaced.

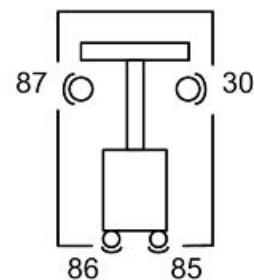

### Switches check

To check buttons and switches, check that, according to their position, the continuity of contacts is correct as indicated in the following charts.

**KEY**

**Ar:** Orange **Az:** Sky Blue **Bi:** White **Bl:** Blue **Gi:** Yellow **Gr:** Grey **Ma:** Brown **Ne:** Black **Ro:** Pink **Rs:** Red **Ve:** Green **Vi:** Purple

**ENGINE STOP SWITCH**

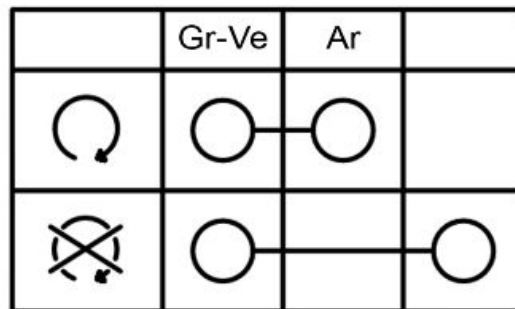

**STARTER BUTTON**

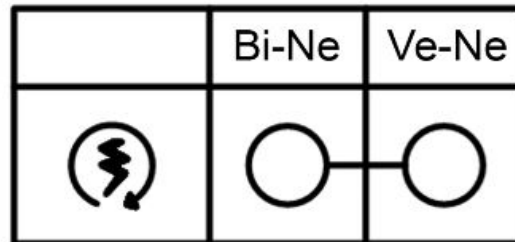

**LIGHT SWITCH**

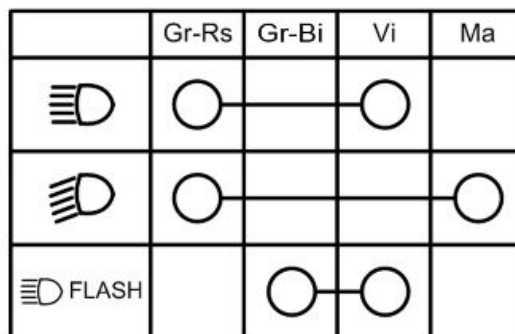

**TURN INDICATOR SWITCH**

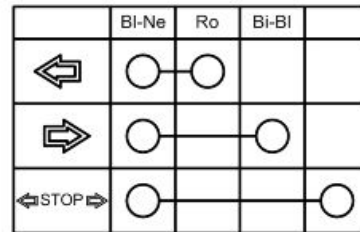

**HORN BUTTON**

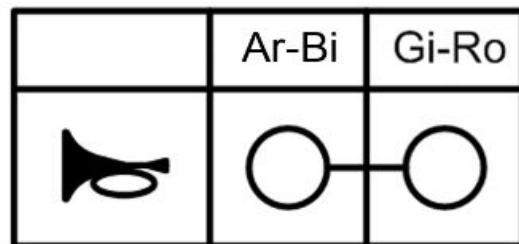

**HELMET COMPARTMENT LIGHT SWITCH**

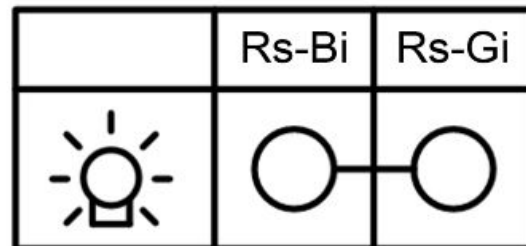

**SADDLE OPENING SWITCH**

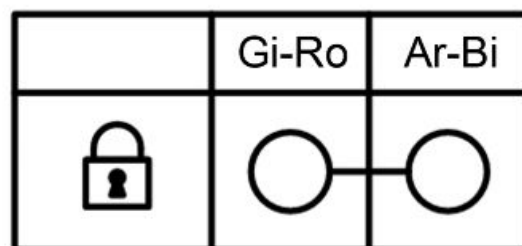

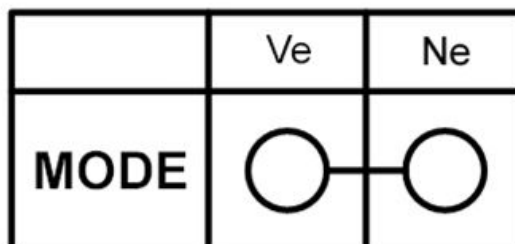
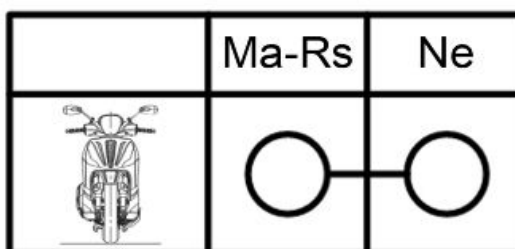
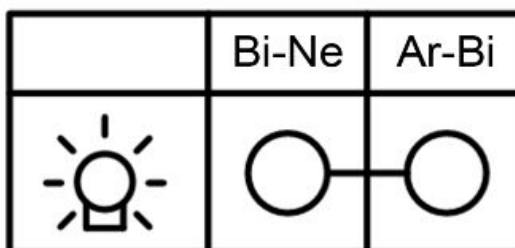
**MODE BUTTON****STAND BUTTON****STOP BUTTONS****Stator check****Checking the stator windings****WARNING**

**THIS CHECK-UP CAN BE MADE WITH THE STATOR PROPERLY INSTALLED.**

- 1) Remove the right side panel.
- 2) Disconnect the connector between stator and regulator with the three yellow cables as shown in the picture.
- 3) Measure the resistance between each of the yellow terminals and the other two.
- 4) Check that there is insulation between the each yellow cable and the ground.

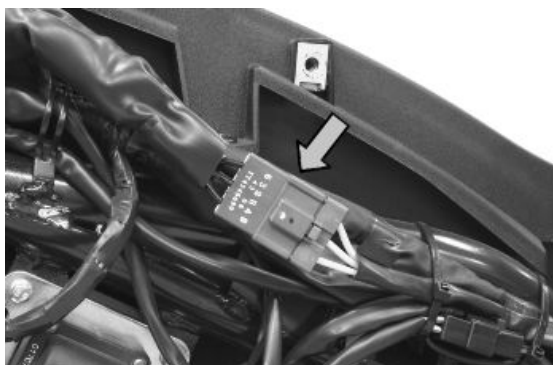

**Electric characteristic****Resistance:**0.2 - 1  $\Omega$ **Voltage regulator check**

With a perfectly charged battery and lights off, measure voltage at the battery poles with a high running engine.

Voltage should not exceed 15 Volt.

In case higher voltages are detected, replace the regulator.

In case of voltage values lower than 14 Volt, check the stator and the corresponding cable harness.

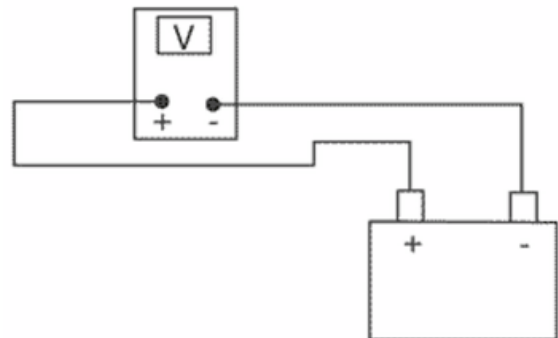
**Electric characteristic****Control voltage**

14÷15 V to 1500÷12000 rpm

**Recharge system voltage check****Look for any leakage**

- 1) Access the battery by removing its cover under the saddle.
- 2) Check that the battery does not show signs of losing fluid before checking the output voltage.
- 3) Turn the ignition key to «OFF», connect the multimeter leads between the battery negative pole (-) and the Black cable. Only then disconnect the Black cable from the battery negative pole (-).
- 4) With the ignition key always «OFF», the reading indicated by the ammeter must be must be  $\leq 0.5$  mA.

**Charging current check****WARNING**

**BEFORE CARRYING OUT THE CHECK, MAKE SURE THAT THE BATTERY IS IN GOOD WORKING ORDER.**

- 1) Place the vehicle on its centre stand
- 2) With the battery correctly connected to the circuit, place the multimeter leads between the battery terminals..
- 3) Turn on the engine, increase the engine rpm and, at the same time, measure the voltage.

**Electric characteristic**

**Voltage ranging between 14.0 and 15.0V at 5000 rpm.**

**Maximum current output check.**

- With the engine off and the panel at «ON» with the lights on, allow the battery voltage to stop at 12V.
- Connect ammeter pliers to the 2 recharge positive poles in output from the regulator.

- Start the engine and rev it up to a high engine speed while reading the value on the pincer.
- With an efficient battery a value must be detected: > 20A

**VOLTAGE REGULATOR/RECTIFIER**

Specification	Desc./Quantity
Type	Non-adjustable three-phase transistor
Voltage	14 to 15V at 5000 rpm with lights off

**Starter motor**

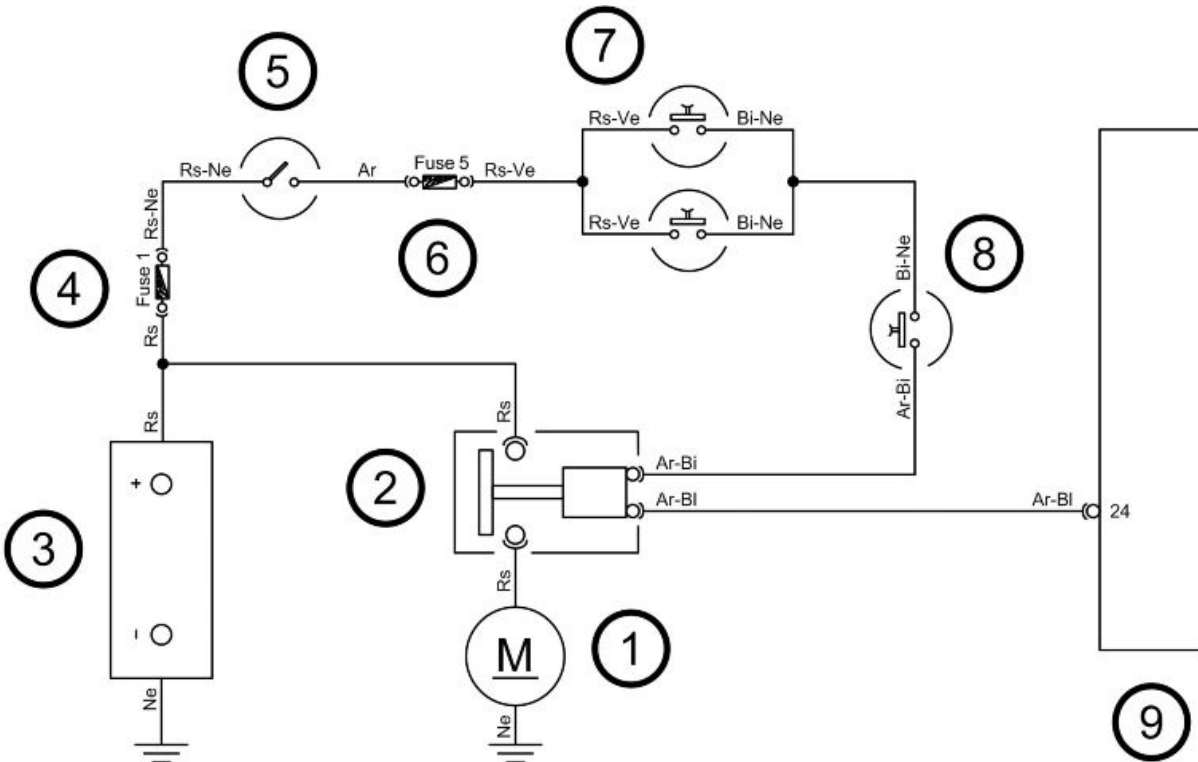

**KEY**

1. Starter motor
2. Starter solenoid
3. Battery
4. Fuse No. 1
5. Ignition key contacts
6. Fuse No. 5
7. Stop buttons
8. Starter button
9. Injection ECU

**WARNING**

**ALL CONTINUITY TESTS MUST BE CARRIED OUT WITH THE CORRESPONDING CONNECTORS DISCONNECTED.**

- 1) Check if there is continuity of the Red cable connecting the battery, the start-up solenoid and the starter motor.

- 2) Check fuses No. 1 and 5, the ignition key contacts, the stop light buttons and the starter button.
- 3) Check the start-up solenoid.
- 4) If components are in good condition, check that the cable harness connecting them is not interrupted.
- 5) Check if there is continuity of the Orange-Blue cable between the start-up solenoid and the control unit connector.

### Horn control

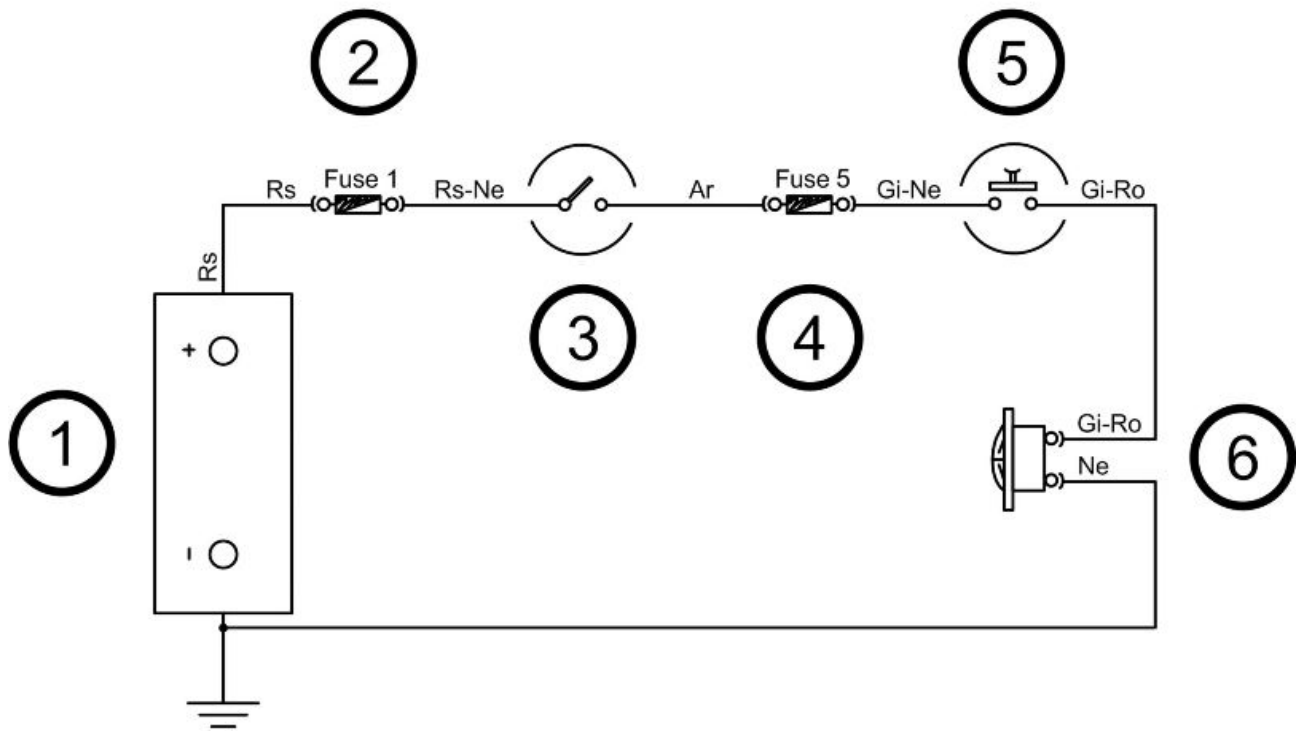

#### KEY

1. Battery
2. Fuse No. 1
3. Ignition key contacts
4. Fuse No. 5
5. Horn button
6. Horn

#### WARNING

**ALL CONTINUITY TESTS MUST BE CARRIED OUT WITH THE CORRESPONDING CONNECTORS DISCONNECTED.**

- 1) Check fuses No. 1 and 5, the ignition key contacts and the horn button.
- 2) If the components are not damaged, check wiring for continuity.
- 3) Check that the Yellow-Pink cable between the horn and horn button is not interrupted.
- 4) Check that the Black cable of the horn is grounded.

## Turn signals system check

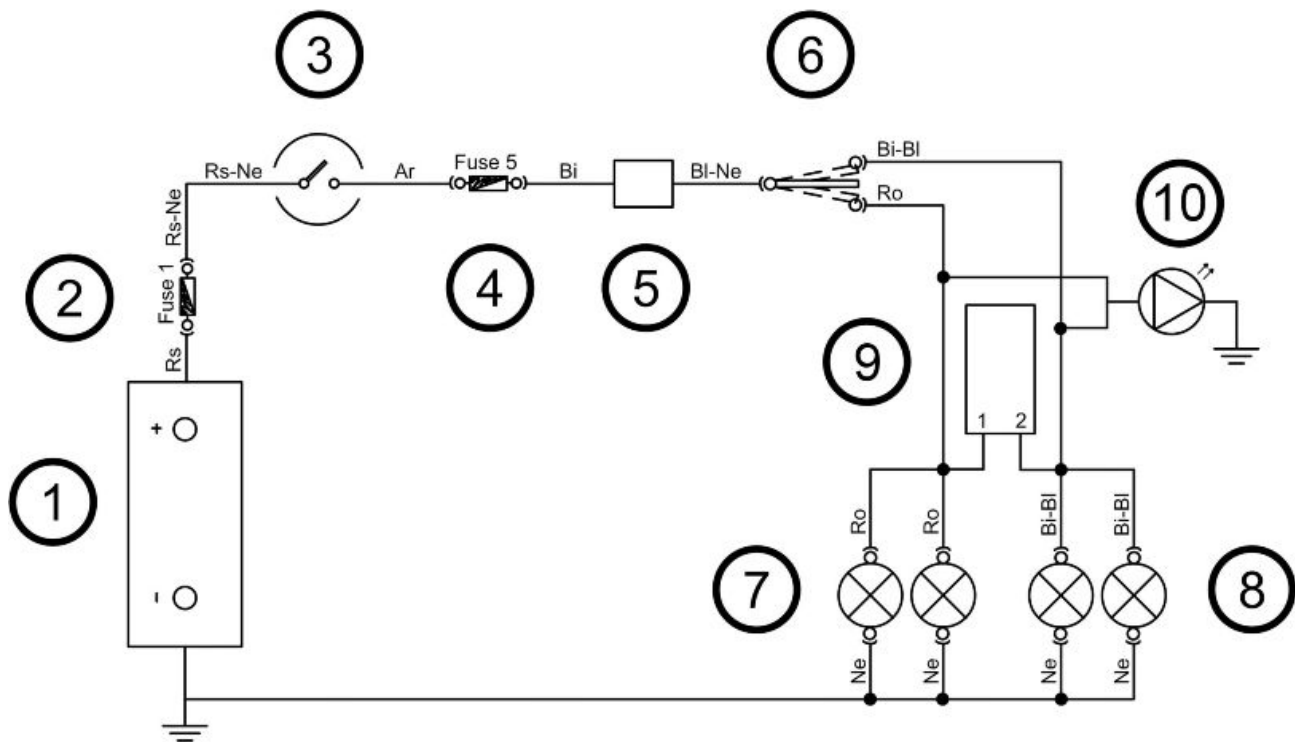
**KEY**

1. Battery
2. Fuse No. 1
3. Ignition key contacts
4. Fuse No. 5
5. Turn indicator control device
6. Turn indicator switch
7. LH indicators
8. RH indicators
9. Antitheft
10. Warning light bulb

**WARNING**

**ALL CONTINUITY TESTS MUST BE CARRIED OUT WITH THE CORRESPONDING CONNECTORS DISCONNECTED.**

- 1) Check the working order of bulbs.
- 2) Check fuses No. 1 and 5 and the ignition key contacts.
- 3) Check if there is intermittent voltage between the Blue-Black cable of the turn indicator control device and the ground connection.
- 4) If there is no voltage, check that the cable harness is not interrupted.
- 5) Check the turn indicator switch.



- 6) Check that the Blue-Black cable between the turn indicator control device and the turn indicator switch is not interrupted.
- 7) Check that the Pink and White-Blue cables connecting the bulbs and the turn indicator switches are not interrupted.
- 8) Check the bulbs ground connection.

## level indicators

### WARNING

**ALL CONTINUITY TESTS MUST BE CARRIED OUT WITH THE CORRESPONDING CONNECTORS DISCONNECTED.**

If faults are detected:

- 1) With a multimeter, check resistance values between the White-Green cable and the Black cable of the fuel level transmitter by moving the arm with the float.
- 2) If the transmitter operates correctly but the indication on the instrument panel is not exact, check that the cable harnesses between them are not interrupted.

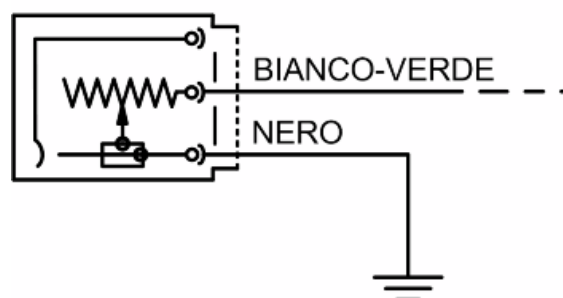

### Electric characteristic

**Resistance value when the tank is full**

$\leq 7 \Omega$

**Resistance value when the tank is empty**

$90 + 13/-3 \Omega$

## Lights list

### BULBS

	Specification	Desc./Quantity
1	Low beam light bulb	Type: Halogen H7 Quantity: 1 Power: 12V - 55W
2	High beam light bulb	Type: Halogen H7 Quantity: 1 Power: 12V - 55W
3	Front tail light bulb	Type: LED Quantity: 1 Right - 1 Left Power: -
4	Front turn indicator light bulb	Type: Spherical BAU 15s Quantity: 1 Right - 1 Left Power: 12V - 10W
5	Stop light/rear daylight running light bulb	Type: LED Quantity: 1 Right - 1 Left Power: -
6	Rear turn indicator light bulb	Type: Spherical BAU 15s Quantity: 1 Right - 1 Left Power: 12V - 10W

	Specification	Desc./Quantity
7	License plate light bulb	Type: All glass W5W Quantity: 1 Power: 12V - 5W
8	Helmet compartment light bulb	Type: Cylindrical C5W Quantity: 1 Power: 12V - 5W
9	Instrument panel lighting bulb	Type: LED Quantity: 4 Power: -

### Line for daylight running lights and instrument panel lighting line

In the event of a malfunction, check:

- Efficiency of the bulbs
- Fuses No. 1 and 5
- Ignition key contacts
- Cable harness continuity

### High beam/low beam light line

In the event of a malfunction, check:

- Efficiency of the bulbs
- Light switch
- Headlight solenoid
- Fuses No. 1, 4, 5 and 6
- Ignition key contacts
- Cable harness continuity

## Fuses

The electrical system is equipped with 6 protection fuses located below the saddle. Open the saddle as described above.

Unscrew the three screws «A» and remove the cover «B»

The chart shows the position and specifications of the fuses in the vehicle.

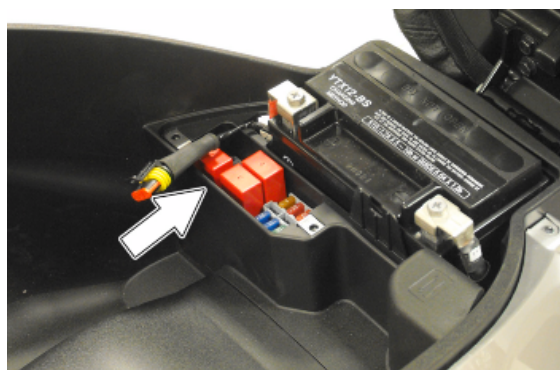

#### CAUTION



**BEFORE REPLACING A BLOWN FUSE, FIND AND SOLVE THE FAILURE THAT CAUSED IT TO BLOW. NEVER TRY TO REPLACE THE FUSE WITH ANY OTHER MATERIAL (E.G., A PIECE OF ELECTRIC WIRE).**

#### CAUTION



**MODIFICATIONS OR REPAIRS TO THE ELECTRICAL SYSTEM, PERFORMED INCORRECTLY OR WITHOUT STRICT ATTENTION TO THE TECHNICAL SPECIFICATIONS OF**

THE SYSTEM CAN CAUSE MALFUNCTIONING AND RISK OF FIRE.

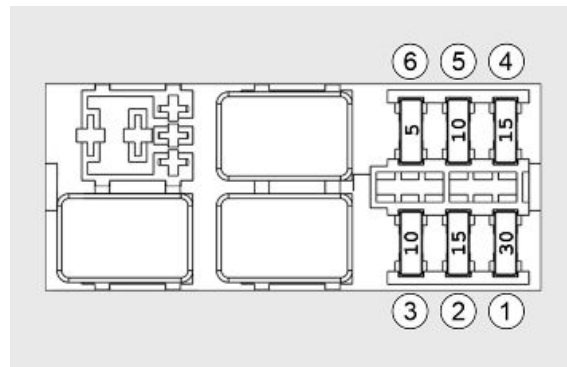

**FUSES**

	Specification	Desc./Quantity
1	Fuse No. 1	<b>Capacity:</b> 30 A <b>Protected circuits:</b> general, recharge battery <b>Live:</b> fuses No. 5 and 6
2	Fuse No. 2	<b>Capacity:</b> 15A <b>Protected circuits:</b> battery-powered: antitheft device pre-installation, saddle opening control unit pre-installation, electric fan relay (contact)
3	Fuse No. 3	<b>Capacity:</b> 10A <b>Protected circuits:</b> battery powered B.T. socket, helmet compartment light bulb, electronic control unit, injection load relay (contact); live saddle opener actuator
4	Fuse No. 4	<b>Capacity:</b> 15 A <b>Protected circuits:</b> battery powered headlight relay (contact), instrument panel
5	Fuse No. 5	<b>Capacity:</b> 10 A <b>Protected circuits:</b> live antitheft pre-installation, saddle opening control unit pre-installation, turn indicator control device, high-beam flash, instrument panel, daylight running light, horn, stop lights, starter enabling switch, licence plate light
6	Fuse No. 6	<b>Capacity:</b> 5A <b>Protected circuits:</b> live headlight relay (coil), immobiliser aerial, electronic control unit, injection load relay (coil)

## Dashboard

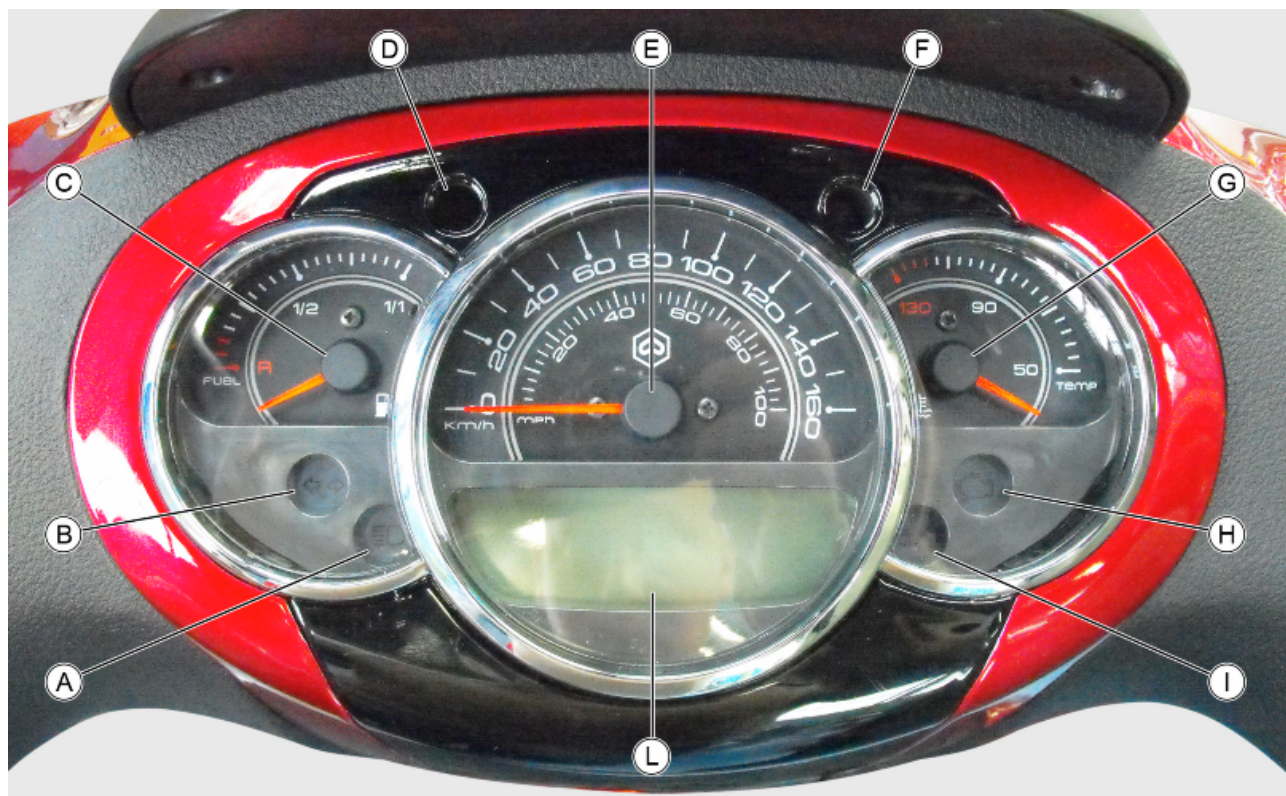

- A= High beam warning light
- B = Turn indicator warning lights
- C = Fuel gauge
- D = Low fuel warning light
- E = Speedometer
- F = Immobiliser LED
- G = Coolant temperature gauge
- H = Engine control telltale light
- I = Engine oil pressure warning light
- L = Digital display

## Sealed battery

If the vehicle is provided with a sealed battery, the only maintenance required is the check of its charge and recharging, if necessary.

These operations should be carried out before delivering the vehicle, and on a six-month basis while the vehicle is stored in open circuit.

Besides upon pre-delivery it is therefore necessary to check the battery charge and recharge it, if required, before storing the vehicle and afterwards every six months.

### INSTRUCTIONS FOR THE RENEWAL RECHARGE AFTER OPEN-CIRCUIT STORAGE

#### 1) Voltage check up

Before installing the battery on the vehicle, check the open circuit voltage with a standard tester.

- If voltage exceeds 12.60 V, the battery can be installed without any renewal recharge.
- If voltage is below 12.60 V, a renewal recharge is required as explained in 2).

### 2) Constant voltage battery charge mode

- Constant voltage charge equal to 14.40 to 14.70V
- Initial charge voltage equal to 0.3 to 0.5 for Nominal capacity
- Charge time:

10 to 12 h recommended

Minimum 6 h

Maximum 24 h

### 3) Constant current battery charge mode

- Charge current equal to 1/10 of the battery rated capacity
- Charge time: Maximum 5 h

---

## Battery installation

### VRLA battery (valve-regulated lead-acid battery) Maintenance Free (MF)

#### WARNING

**BATTERY ELECTROLYTE IS TOXIC AND IT MAY CAUSE SERIOUS BURNS. IT CONTAINS SULPHURIC ACID. AVOID CONTACT WITH YOUR EYES, SKIN AND CLOTHING. IF COMING INTO CONTACT WITH EYES OR SKIN, WASH ABUNDANTLY WITH WATER FOR APPROX. 15 MIN. AND SEEK IMMEDIATE MEDICAL ATTENTION.**

**IN THE EVENT OF ACCIDENTAL INGESTION OF THE LIQUID, IMMEDIATELY DRINK LARGE QUANTITIES OF WATER OR MILK, MAGNESIUM MILK, BATTERED EGG OR VEGETABLE OIL. SEEK IMMEDIATE MEDICAL ATTENTION.**

**BATTERIES PRODUCE EXPLOSIVE GASES; KEEP CLEAR OF NAKED FLAMES, SPARKS OR CIGARETTES; VENTILATE THE AREA WHEN RECHARGING INDOORS.**

**ALWAYS WEAR EYE PROTECTION WHEN WORKING IN THE PROXIMITY OF BATTERIES.**

**KEEP OUT OF REACH OF CHILDREN**

#### 1) Battery preparation

Position the battery on a flat surface. Remove the adhesive sheet closing cells and proceed as quickly as possible to run the subsequent activation phases.

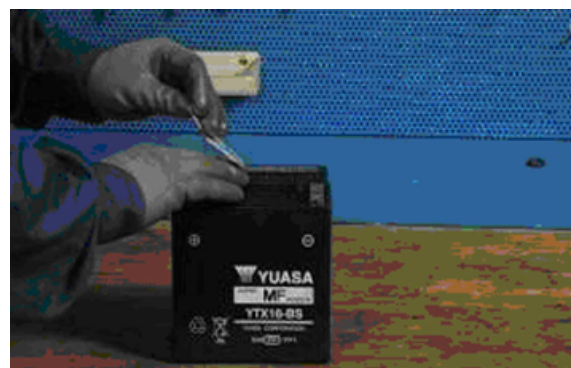

**2) Electrolyte preparation.**

Remove the container of the electrolyte from the pack. Remove and preserve cover strips from the container, in fact, the strip will later be used as a closing cover.

**Note:** Do not pierce the sealing of the container or the container itself because inside there is sulphuric acid.

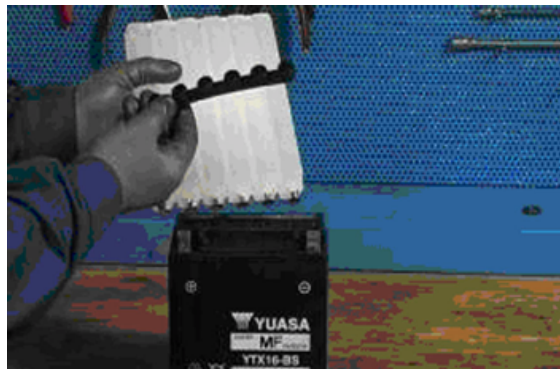
**3) Procedure for filling the battery with acid.**

Position the electrolyte container upside down with the six areas sealed in line with the six battery filler holes. Push the container down with enough force to break the seals. The electrolyte should start to flow inside the battery.

**Note:** Do not tilt the container to prevent the flow of electrolyte from pausing or stopping.

**4) Control the flow of electrolyte**

Make sure air bubbles are rising from all six filling holes. Leave the container in this position for 20 minutes or more.

**Note:** If there are no air bubbles coming out of the filling holes, lightly tap the bottom of the container two or three times. Do not remove the container from the battery.

**5) Take out the container.**

Make sure all the electrolyte in the battery is drained. Gently tap the bottom of the container if electrolyte remains in the container. Now, gently pull the container out from the battery, only do this when the container is completely empty, and proceed immediately to the next point.

**6) Battery closing.**

Insert the airtight cover strips into the filling holes. Press horizontally with both hands and make sure that the strip is levelled with the top part of the battery.

**Note:** To do this, do not use sharp objects that could damage the closing strip, use gloves to protect your hands and do not bring your face close to the battery.

The filling process is now complete.

Do not remove the strip of caps under any circumstances, do not add water or electrolyte.

Place the battery down for 1 to 2 hours prior to the charging from the battery.

### 7) Recharging the new battery

With the above-mentioned procedure, the battery will have gained around 70% - 75% of its total electrical capacity. Before installing the battery on the vehicle, it must be fully charged and then must be recharged.

**If the battery is to be installed on the vehicle prior to this pre-charged one, the battery will not be able to exceed 75% charge without jeopardising its useful life on vehicle.**

The dry charge battery MF like the completely loaded YTX, must have a no-load voltage between 12.8 - 13.15 V Bring the battery to full charge, using the 020648Y battery charger:

- a - select the type of battery with the red switch on the left of the panel battery charger panel
- b - select NEW on the yellow timer
- c - connect the clamps of the battery charger to the battery poles (black clamp to negative pole (-) and red clamp to positive pole (+)).



- d - Press the red button, as shown in figure.



- e - Press the "MF" black button to activate the battery recharge **Maintenance Free** as shown in figure.



f - Check the ignition of the green LED indicated with a red arrow in figure.



g - The activation cycle of the new battery lasts for 30 minutes after the ignition of the recharge LED has taken place



h - Disconnect the clamps from the battery and check the voltage, if voltages are detected of less than 12.8 V, proceed with a new recharge of the battery starting from point c of the recharge procedure of **the new battery**, otherwise go to point i



i - The battery is now completely activated, disconnect the battery charger from the fuel supply grid, disconnect the clamps from the battery and proceed to fitting the battery on the vehicle.



## Connectors

### INSTRUMENT PANEL CONNECTOR «A»

1. Left turn indicator warning light (Pink)
2. Immobilizer (Red-Green)
3. Battery-powered (Red-Black)
4. Coolant temperature sensor (Green-Yellow)
5. Not connected
6. Fuel level transmitter (White-Green)
7. Right turn indicator warning light (White-Blue)
8. Low fuel warning light (Grey-Black)

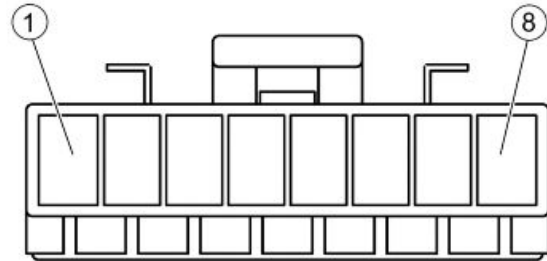

### INSTRUMENT PANEL CONNECTOR «B»

1. High-beam warning light (Violet)
2. Ground lead (Black)
3. Injection warning light (Brown-Black)
4. Oil pressure sensor (Pink-White)
5. Live power supply (White)
6. Instrument panel lighting (Yellow-Black)

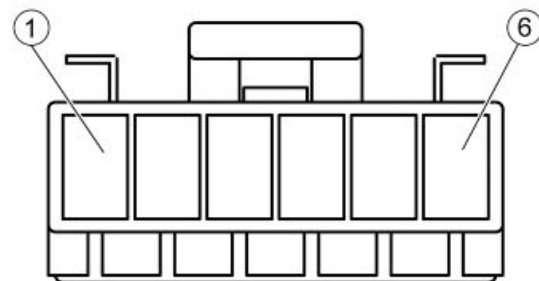

### IMMOBILIZER AERIAL CONNECTOR

1. Live power supply (Red-White)
2. Ground lead (Black)
3. Injection ECU (Orange-White)

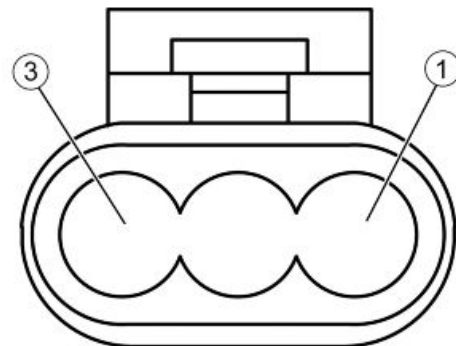

### FUEL PUMP CONNECTOR

1. Not connected
2. Ground lead (Black)
3. Not connected
4. Not connected
5. Power from solenoid (Black-Green)

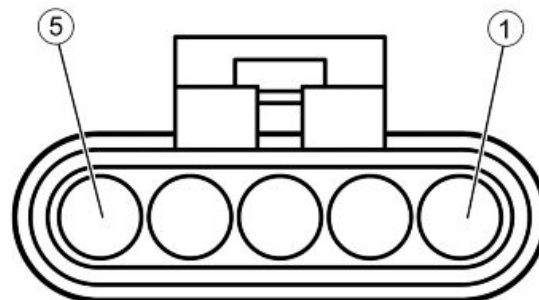

**ELECTRIC FAN CONNECTOR**

1. Ground lead (Black)
2. Power from solenoid (Red)

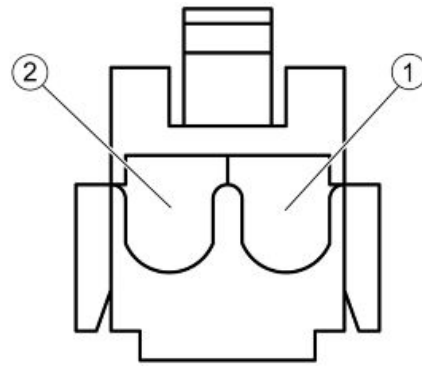
**PICKUP CONNECTOR**

1. Engine speed sensor ECU positive (Red)
2. Engine speed sensor ECU negative (Brown)
3. Oil pressure sensor (White-Pink)

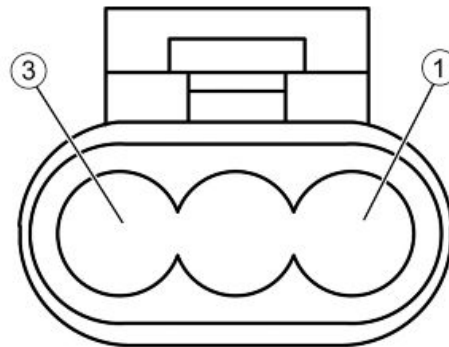
**ANTITHEFT DEVICE PRE-INSTALLATION CONNECTOR**

1. Left turn indicator bulbs (Pink)
2. Right turn indicator bulbs (White-Blue)
3. Ground lead (Black)
4. Battery-powered (Blue)
5. Live power supply (White)
6. Helmet compartment light (Red-Yellow)
7. Not connected
8. Not connected

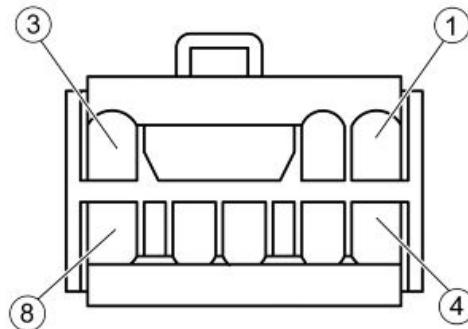
**2-PIN CONNECTOR ONLY**

- 1 Sky blue-black positive from control unit
- 2 White-Green negative from control unit

**VOLTAGE REGULATOR CONNECTOR**

1. Battery positive (Red-Black)
2. Ground lead (Black)
3. Battery positive (Red-Black)
4. Ground lead (Black)

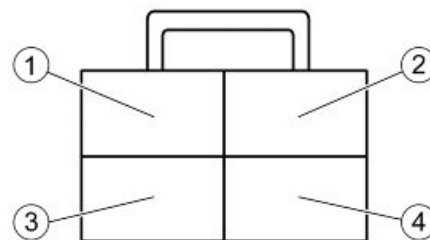

**INJECTION ELECTRONIC CONTROL UNIT**

**CONNECTOR**

1. Injection warning light (Brown-Black)
2. Not connected
3. Not connected
4. Lambda probe negative (White-Green)
5. Live power supply (Red-White)
6. Battery-powered (Orange-Black)
7. Immobilizer aerial (Orange-White)
8. Electric fan solenoid (Blue-Yellow)
9. Coolant temperature sensor (Sky blue-Green)
10. Not connected
11. Lambda probe positive (Sky blue-Black)
12. Engine stop switch (Green-Black)
13. Engine speed sensor positive (Red)
14. Injector negative (Yellow-Red)
15. Engine speed sensor negative (Brown)
16. Diagnostics socket (Purple-White)
17. Immobilizer LED (Red-Green)
18. Side stand (Sky blue)
19. Not connected
20. Injection load solenoid (Black-Purple)
21. Not connected
22. HV coil negative (Pink-Black)
23. Not connected
24. Start-up solenoid (Orange-Blue)
25. Fall sensor
26. Ground lead (Black)

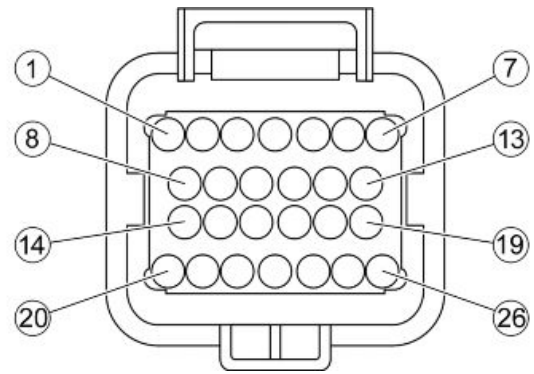

**INJECTOR CONNECTOR**

1. Power from solenoid (Black-Green)
2. Negative from control unit (Yellow-Red)

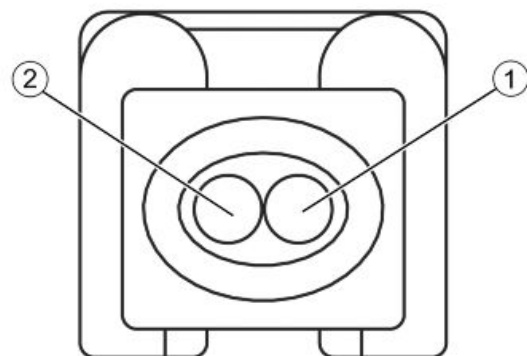

**HV COIL CONNECTOR**

1. Negative from control unit (Red-Black)
2. Power from solenoid (Black-Green)

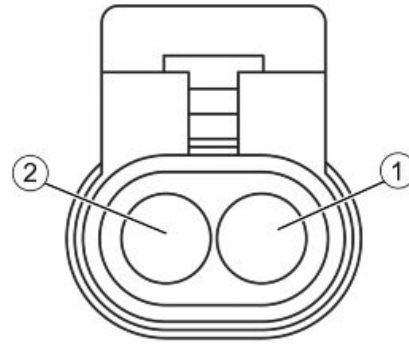
**FUEL LEVEL TRANSMITTER CONNECTOR**

1. Low fuel warning light (Grey-Black)
2. Ground lead (Black)
3. Fuel level indicator (White-Green)

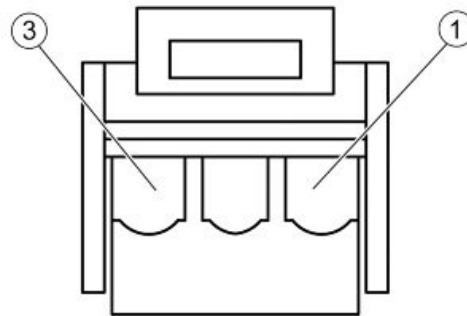
**COOLANT TEMPERATURE SENSOR CONNECTOR**

1. Ground lead (Grey-Green)
2. Instrument panel (Green-Yellow)
3. Injection ECU (Sky blue-Green)
4. Ground lead (Black)

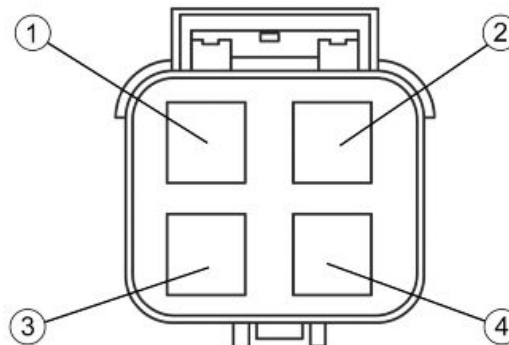

## INDEX OF TOPICS

ENGINE FROM VEHICLE

ENG VE

Questa sezione descrive le operazioni da effettuare per lo smontaggio del motore dal veicolo.

## Exhaust assy. Removal

- Remove the RH footrest.
- Remove the Lambda probe from its support and disconnect it.
- Cut the fastening clamp on the lambda probe cable.

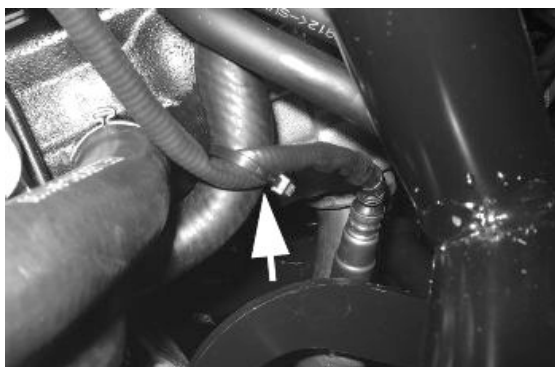

- Undo the two exhaust manifold fixings on the head. To unscrew the nuts that fix the silencer flange to the head properly, use a jointed wrench that allows, according to the travel direction, to get also at the right nut. That is difficult to do with a traditional straight wrench.

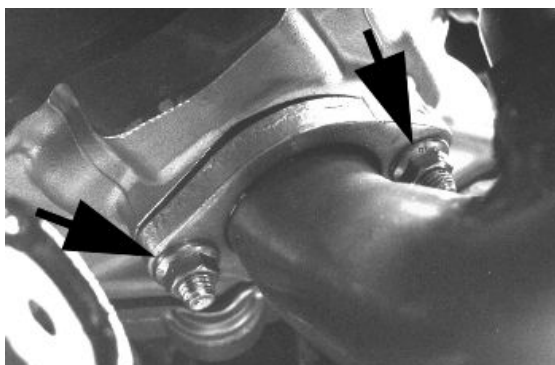

- Unscrew the three screws fastening the heat shield to the silencer;
- Unscrew the three screws «A» fastening the silencer to the silencer mounting bracket.
- Remove the full silencer unit.

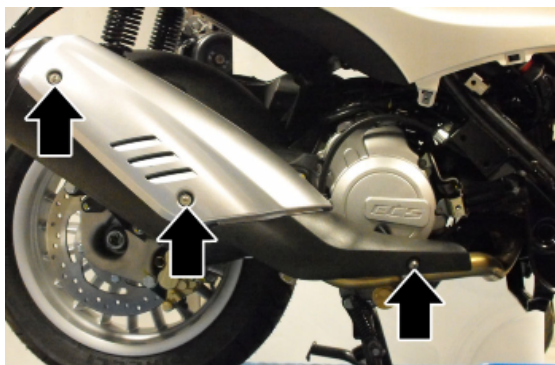

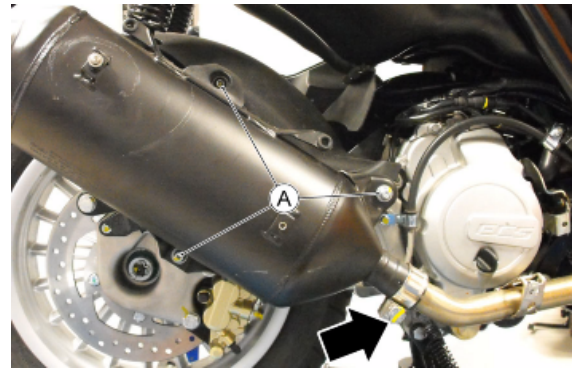

Remove the lambda probe from the manifold.



## Removal of the engine from the vehicle

### CAUTION



### SUPPORT THE VEHICLE ADEQUATELY.

Disconnect the battery.

- Remove the side fairings.
- Remove the inspection cover in helmet compartment.
- Remove the full silencer unit.
- Remove the air filter.
- Release the blow-by return pipe from the clamp and disconnect it from the head.

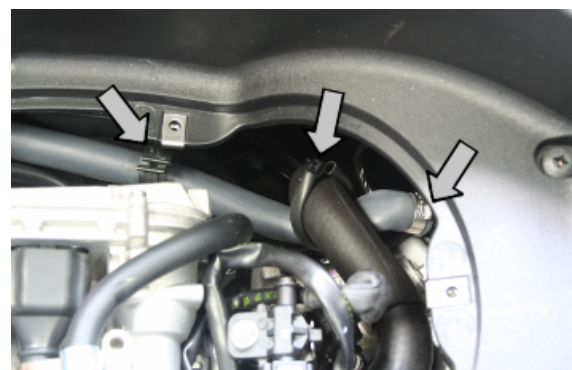

### CAUTION



**THIS OPERATION MUST BE CARRIED OUT WHEN THE ENGINE IS COLD.**

- Unscrew the screw indicated in the figure and release the rear brake hose from the silencer mounting bracket;

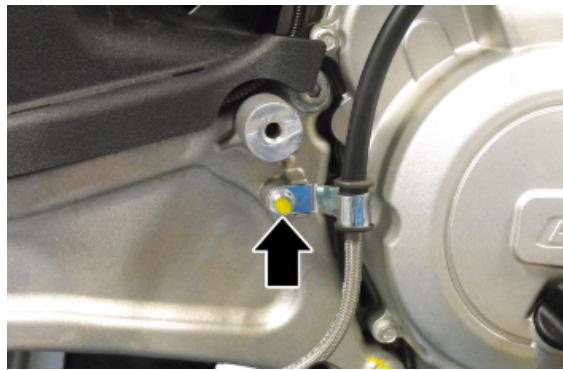

- Unscrew the two bolts fastening the rear brake calliper to the silencer mounting bracket;

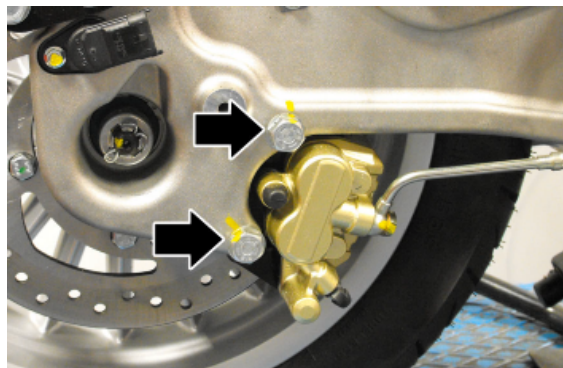

- Working on the vehicle right side, remove the coolant intake pipes and empty the system.

**N.B.**

**LET THE COOLANT DRAIN INTO A CONTAINER OF ADEQUATE CAPACITY.**

**Characteristic**  
**Cooling system fluid**

~ 2 l

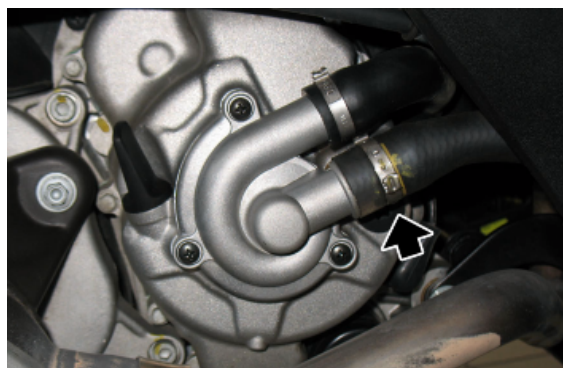

- Disconnect:
- fuel piping and retainer clamp.
- injector connector.
- control unit connector.

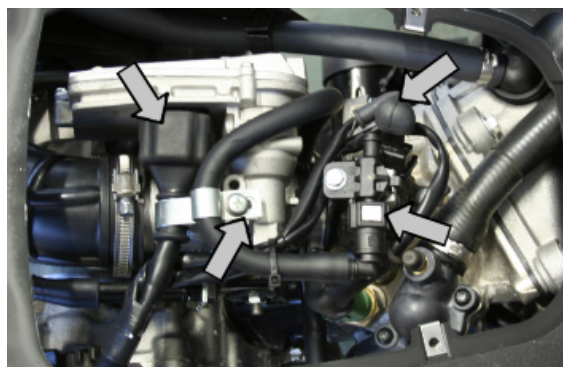



- 
- Remove the coolant outlet pipe from the engine as indicated.

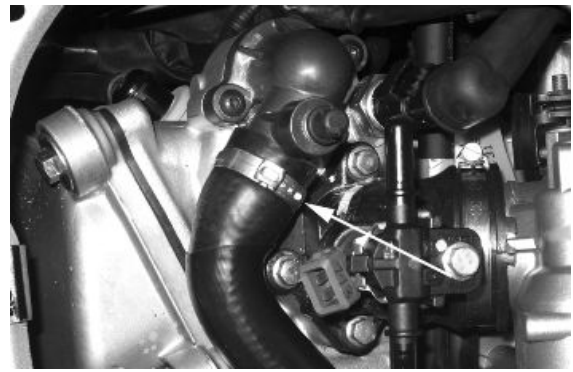

- 
- Remove the spark plug cap.
  - Remove the coolant temperature sensor connector indicated in the picture.



- 
- Remove the throttle cables from the throttle body by undoing the nuts indicated in the picture.



- 
- Remove the positive and negative wiring from the starter motor as shown in the picture.

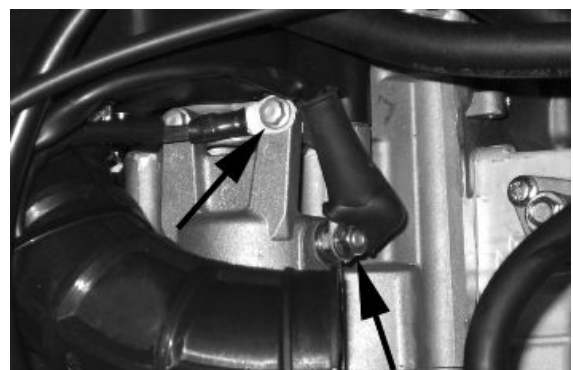

- Release the cable harness from the cable grommet clamp and remove the clamp indicated.
- Disconnect the oil minimum pressure sensor.

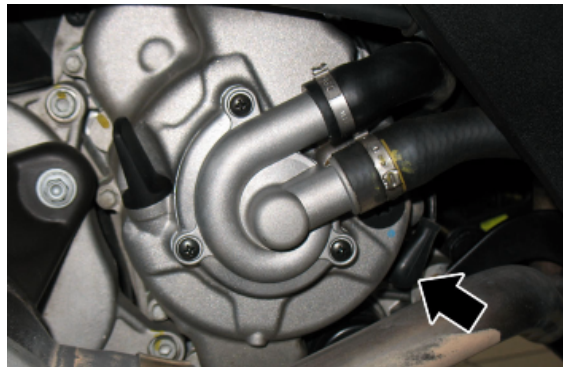
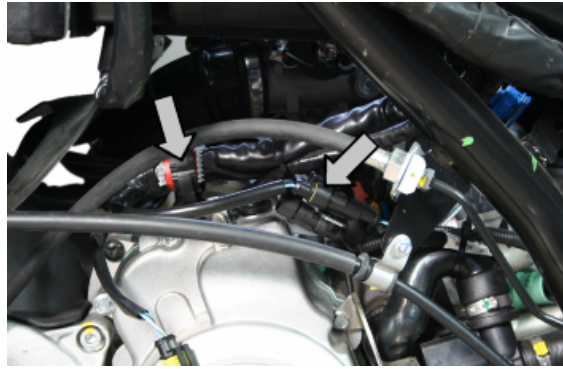

- Remove the lower screws of the right and left shock absorber.

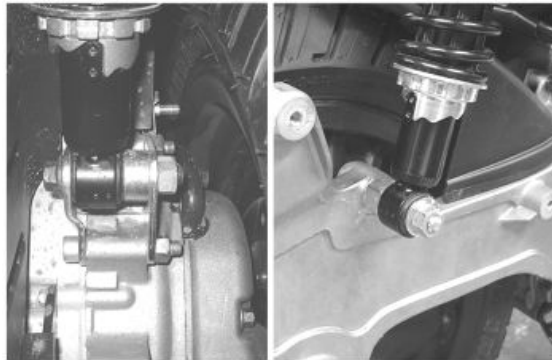

- Take out the ground retainer on the engine.

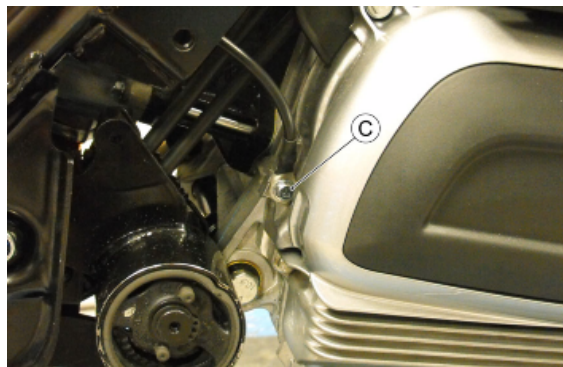

- Remove the pin fixing the engine to the swinging arm.
- The engine is now free.

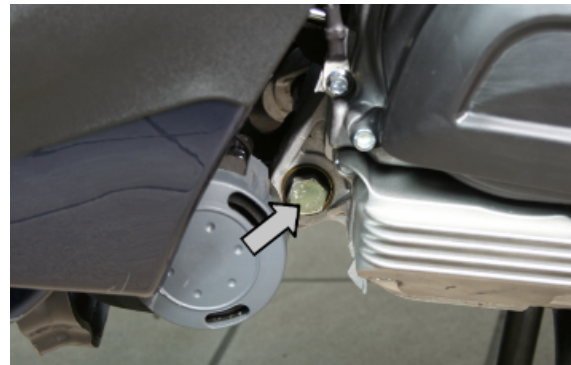
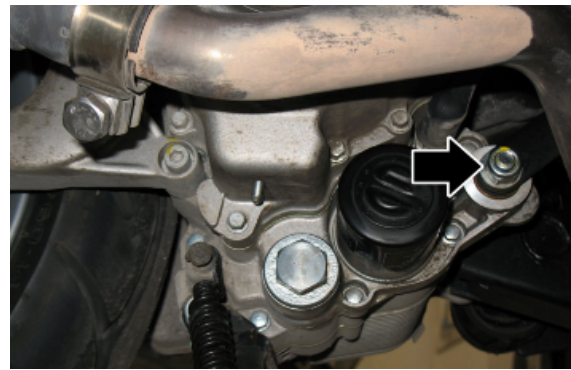

Upon refitting the engine to the vehicle, carry out the removal operations but in reverse order, and respect the tightening torque shown in the «Specifications» Chapter.

- Check that there is a small clearance when the valve is in abutment against the set screw.
- Check the engine oil level and if necessary, top it up with the recommended type.
- Fill and bleed the cooling circuit.
- Check accelerator and electric devices for correct functioning.
- Pay particular attention to the sleeve, be careful to position the throttle body reference marks as indicated in the picture.

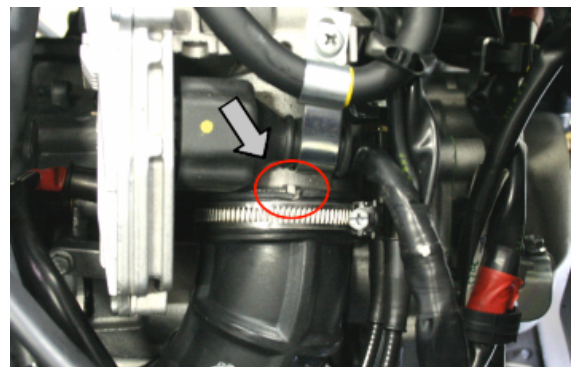
**CAUTION**

**PAY PARTICULAR ATTENTION TO POSITIONING THE THROTTLE CONTROL TRANSMISSION PROPERLY.**

# INDEX OF TOPICS

ENGINE

ENG

---

This section describes the operations to be carried out on the engine and the tools to be used.

---

This section describes the operations to be carried out on the engine and the tools to be used.

---

This section describes the operations to be carried out on the engine and the tools to be used.

---

## Automatic transmission

---

### Transmission cover

---

- Remove the air duct.
- With the specific tool lock the driven pulley, undo the indicated nut and collect the washer.

#### Specific tooling

**020423Y Driven pulley lock wrench**

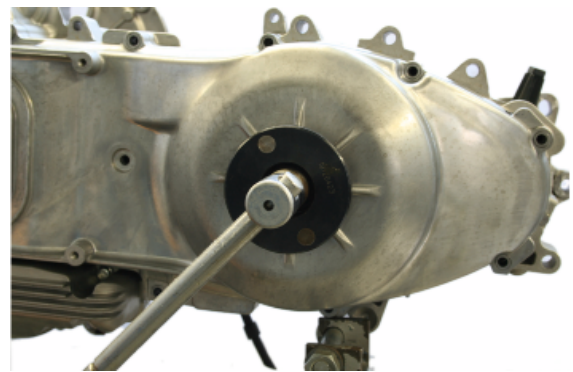

- Undo the eleven fixings screws to the engine and remove the transmission cover

#### N.B.

**WHEN YOU ARE REMOVING THE TRANSMISSION COVER YOU MUST BE CAREFUL NOT TO DROP THE CLUTCH HOUSING.**

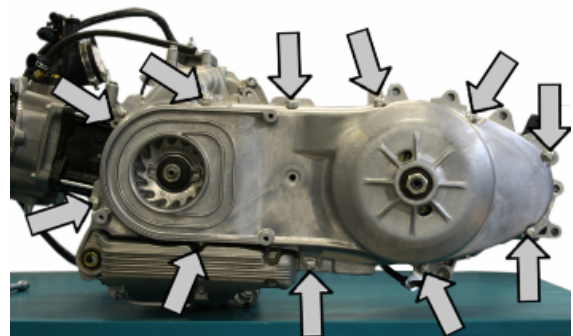

### Air duct

---

- Undo the three screws «1» and remove the crankcase cover «2».

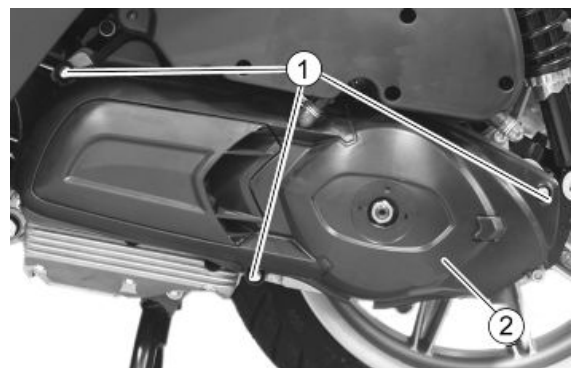

- Undo the three screws «3» and remove the filter cover in the transmission housing «4».

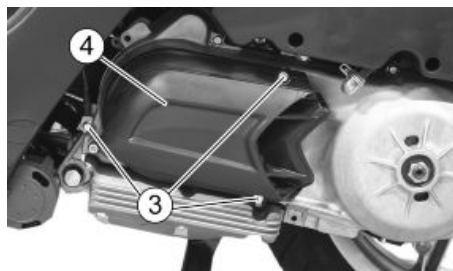

- Take out the filtering element «5» from the cover.



## Removing the driven pulley shaft bearing

- Remove the clip from the inside of the cover.
- Remove the bearing from the crankcase by means of:

### Specific tooling

020376Y Adaptor handle

020375Y 28 x 30 mm adaptor

020412Y 15-mm guide



## Refitting the driven pulley shaft bearing

- Heat the crankcase from the inside.
- Insert the bearing in its seat.
- Refit the Seeger ring.

### CAUTION

USE AN APPROPRIATE SUPPORT TO AVOID DAMAGING THE COVER SURFACE.

### N.B.

ALWAYS REPLACE THE BEARING WITH A NEW ONE UPON REFITTING.

### Specific tooling

020376Y Adaptor handle

020357Y 32x35-mm Adaptor

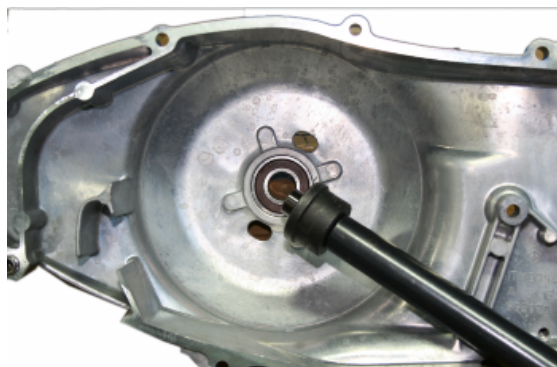

---

020412Y 15-mm guide

---

## Removing the driven pulley

- Remove the stationary driving half-pulley and the clutch housing.
- Remove the driven pulley together with the belt.

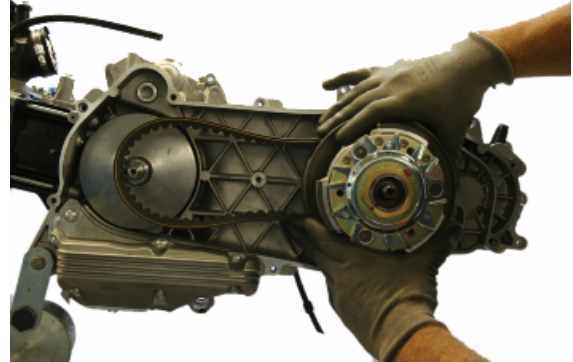

---

## Inspecting the clutch drum

- Check that the clutch bell is not worn or damaged.
- Measure the clutch bell inside diameter.

### Characteristic

#### Max. value clutch bell

Max. value:  $\varnothing$  134.5 mm

#### clutch housing standard value

Standard value:  $\varnothing$  134 - 134.2 mm



---

## Checking the bell working surface eccentricity

- Install the bell on a driven pulley shaft using 2 bearings (inside diameter: 15 and 17 mm).
- Lock with the original spacer and nut.
- Place the bell/shaft unit on the support to check the crankshaft alignment.

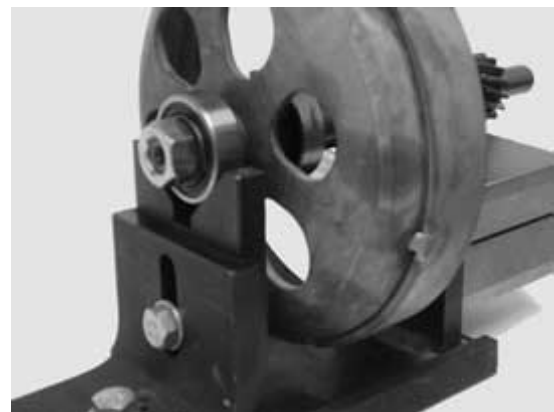

- Using a feeler dial gauge and the magnetic base, measure the bell eccentricity.
- Repeat the measurement in 3 positions (Central, internal, external).
- If faults are found, replace the bell.



### Specific tooling

**020074Y Support base for checking crankshaft alignment**

**020335Y Magnetic mounting for dial gauge**

### Characteristic

**clutch bell inspection: Limit eccentricity.**

Admissible limit eccentricity: 0.15 mm

## Removing the clutch

Fit the driven pulley spring compressor specific tool with medium length pins screwed in position «C» on the tool internal side.

- Introduce the adapter ring 11 with the chamfering facing the inside of the tool.
- Fit the driven pulley unit on the tool with the insertion of the 3 pins in the ventilation holes in the mass holder support.
- Make sure that the clutch is perfectly inserted into the adapter ring before proceeding to loosen/tighten the clutch nut.
- Use the special 46x55 wrench component 9 to remove the nut fixing the clutch in place.
- Dismantle the driven pulley components (Clutch and spring with its plastic holder)

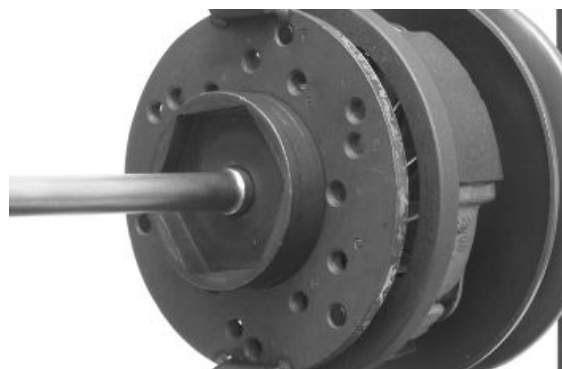

### CAUTION

**THE TOOL MUST BE FIRMLY FIXED IN THE CLAMP AND THE CENTRAL SCREW MUST BE BROUGHT INTO CONTACT WITH THE TOOL. EXCESSIVE TORQUE CAN CAUSE THE SPECIFIC TOOL TO BUCKLE.**

### Specific tooling

**020444Y011 adapter ring**

**020444Y009 wrench 46 x 55**

**020444Y Tool for fitting/ removing the driven pulley clutch**



## Inspecting the clutch

- Check the thickness of the clutch mass friction material.
- The masses must not show traces of lubricants; otherwise, check the driven pulley unit seals.

**N.B.**

UPON RUNNING-IN, THE MASSES MUST EXHIBIT A CENTRAL FAYING SURFACE AND MUST NOT BE DIFFERENT FROM ONE ANOTHER. VARIOUS CONDITIONS CAN CAUSE THE CLUTCH TO TEAR.

**CAUTION**

DO NOT OPEN THE MASSES USING TOOLS TO PREVENT A VARIATION IN THE RETURN SPRING LOAD.



### Characteristic

#### Check minimum thickness

1 mm

## Pin retaining collar

- Simultaneously turn and pull the collar manually to remove it.

**N.B.**

USE TWO SCREWDRIVERS IF YOU HAVE ANY DIFFICULTY.

**N.B.**

BE CAREFUL NOT TO PUSH THE SCREWDRIVERS IN TOO FAR TO AVOID DAMAGE THAT COULD COMPROMISE THE O-RING SEAL.



- Remove the 4 torque server pins and pull the pulley halves apart.



## Removing the driven half-pulley bearing

- Check there are no signs of wear and/or noise; - Replace with a new one if there are.
- Remove the retainer ring using two flat blade screwdrivers.
- Support the pulley bushing adequately from the threaded side using a wooden surface.
- Using a hammer and pin, knock the ball bearing out as shown in the figure.

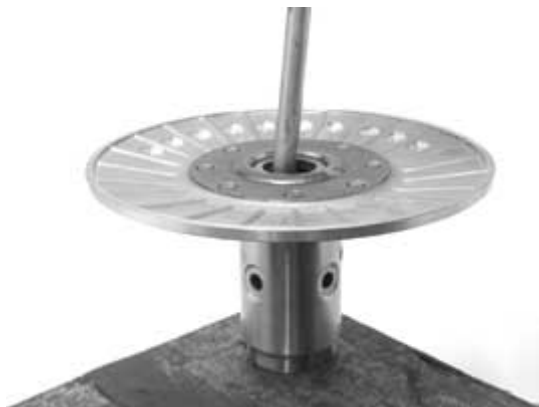

- Support the pulley properly using the bell as shown in the figure.

### Specific tooling

001467Y035 Bearing housing, out  $\varnothing$  47 mm



- Remove the roller bearing using the modular punch.

### Specific tooling

020376Y Adaptor handle

020456Y  $\varnothing$  24 mm adaptor

020363Y 20-mm guide

## Inspecting the driven fixed half-pulley

Version 250

- Measure the outside diameter of the pulley bushing.
- Check the faying surface with the belt to make sure there are no flaws.
- Check the riveted joints are functional.
- Check the evenness of the belt contact surface.

### Characteristic

#### Half-pulley minimum diameter

Minimum admissible diameter:  $\varnothing$  40.96 mm



**Half-pulley standard diameter**

Standard diameter: Ø 40.985 mm

**Wear limit**

0.3 mm



**Inspecting the driven sliding half-pulley**

- Remove the two seal rings and the two O-rings.
- Measure the movable half-pulley bushing inside diameter.
- Check the faying surface with the belt to make sure there are no flaws.
- Check the riveted joints are functional.
- Check the evenness of the belt contact surface.

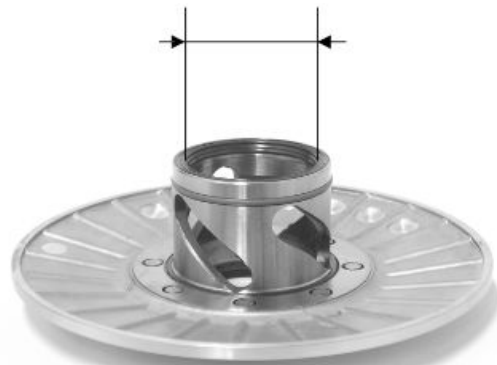

**MOVABLE DRIVEN HALF-PULLEY DIMENSIONS**

Specification	Desc./Quantity
Wear limit	0.3 mm
standard diameter	Ø 41.000 - 41.035 mm
maximum allowable diameter	Ø 41.08 mm

## Refitting the driven half-pulley bearing

- Support the pulley bushing adequately from the threaded side using a wooden surface.
- Fit a new roller bearing as shown in the figure.
- For the fitting of the new ball bearing, follow the example in the figure using a modular punch.

Fit the retainer ring

### WARNING

N.B.

FIT THE BALL BEARING WITH THE VISIBLE SHIELDING

### Specific tooling

020376Y Adaptor handle

020375Y 28 x 30 mm adaptor

020424Y Driven pulley roller casing fitting punch



## Refitting the driven pulley

- Insert the new oil seals and O-rings on the movable half-pulley.
- Lightly grease the O-rings «A» shown in the figure.
- Fit the half-pulley over the bushing using the specific tool.
- Check that the pins are not worn and proceed to refitting them in their slots.
- Refit the torque server closure collar.
- Using a curved-spout grease gun, lubricate the driven pulley unit with approximately 6 grams of grease. Apply grease through one of the holes in the bushing until it comes out through the hole on the opposite side. This operation is necessary to avoid the presence of grease beyond the O-rings.

N.B.

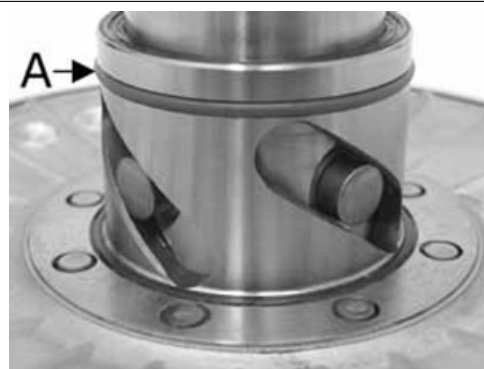

THE TORQUE SERVER CAN BE GREASED WHETHER WITH BEARINGS FITTED OR WHEN THEY ARE BEING REPLACED; UNDERTAKING THE OPERATION WHEN THE BEARINGS ARE BEING SERVICED MIGHT BE EASIER.

### Specific tooling

020263Y Driven pulley assembly sheath

### Recommended products

**AGIP GREASE SM 2 Grease for the C-ring of the tone wheel**

Soap-based lithium grease containing NLGI 2 Molybdenum disulphide; ISO-L-XBCHB2, DIN KF2K-20



## Inspecting the clutch spring

- Measure the length of the spring when it is relaxed.

### Characteristic

#### Standard length

145 mm

#### Acceptable limit after use

140 mm

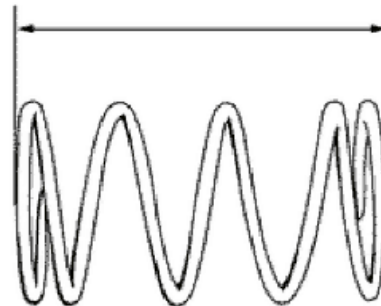

## Refitting the clutch

- Support the driven pulley spring compressor specific tool with the control screw in vertical axis.
- Arrange the tool with the medium length pins screwed in position "C" on the inside.
- Introduce the adapter ring No. 11 with the chamfering facing upwards.
- Insert the clutch on the adapter ring.
- Lubricate the end of the spring that abuts against the torque server closing collar.
- Insert the spring with its plastic holder in contact with the clutch.
- Insert the drive belt into the pulley unit according to their direction of rotation.
- Insert the pulley unit with the belt into the tool.
- Slightly preload the spring.



- Make sure that the clutch is perfectly inserted into the adapter ring before proceeding to tighten the clutch nut.
- Place the tool in the clamp with the control screw on the horizontal axis.
- Fully preload the spring.
- Apply the clutch fixing nut and tighten it to the prescribed torque using the special 46x55 wrench.
- Loosen the tool clamp and insert the belt according to its direction of rotation.
- Lock the driven pulley again using the specific tool.
- Preload the clutch return spring with a traction/ rotation combined action and place the belt in the smaller diameter rolling position.
- Remove the driven pulley /belt unit from the tool.

**N.B.**

DURING THE SPRING PRELOADING PHASE, BE CAREFUL NOT TO DAMAGE THE PLASTIC SPRING STOP AND THE BUSHING THREADING.

**N.B.**

FOR DESIGN REASONS, THE NUT IS SLIGHTLY ASYMMETRIC; THE FLATTEST SURFACE SHOULD BE MOUNTED IN CONTACT WITH THE CLUTCH.

**Specific tooling**

**020444Y Tool for fitting/ removing the driven pulley clutch**

**020444Y011 adapter ring**

**020444Y009 wrench 46 x 55**

**Locking torques (N\*m)**

**Clutch unit nut on driven pulley 45 to 50**

---

**Refitting the driven pulley**

---

- Fit the clutch housing on the driven pulley paying attention to the position of the washer indicated.

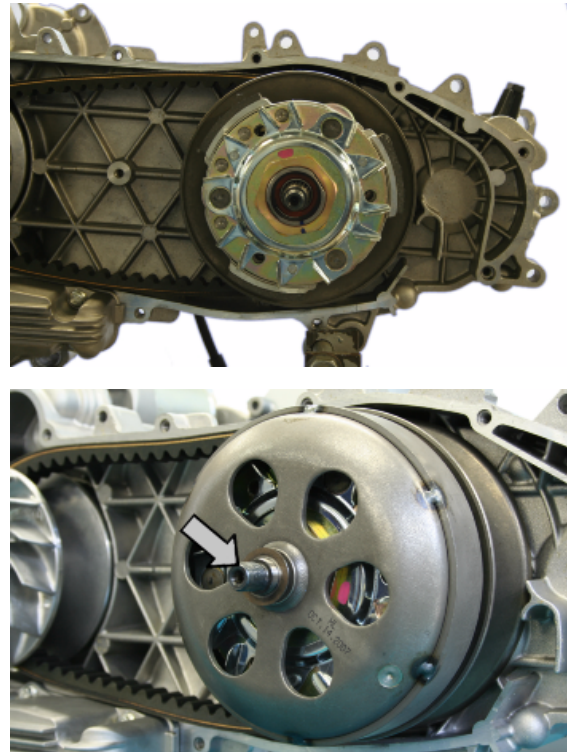

---

**Drive-belt**

- Make sure the drive belt is not damaged and does not show abnormal wear.
- Replace as indicated in the scheduled maintenance table.

---

**Removing the driving pulley**

---

- Turn the crankshaft until the ropes of the pulley are on a horizontal axis

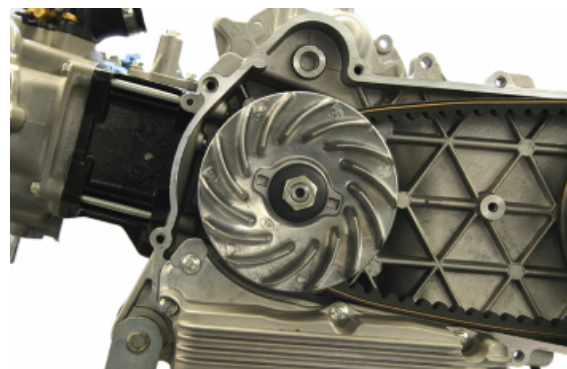

- Insert the adaptor sleeve of the appropriate tool in the hole shown in the picture

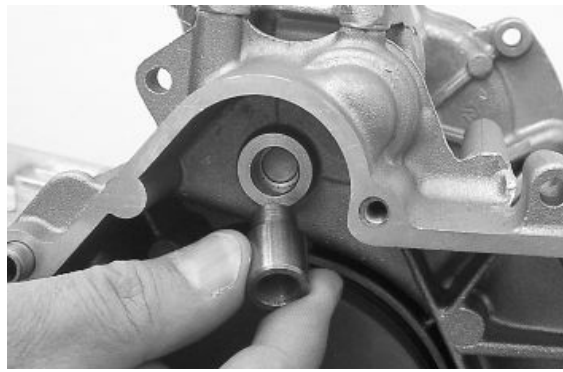

- Insert the tool in the hollows and apply the retention ring
- Bring in the ring's clamping screws while keeping the tool to support the pulley
- Remove the fixing nut and the washer
- Remove the stationary drive pulley half.

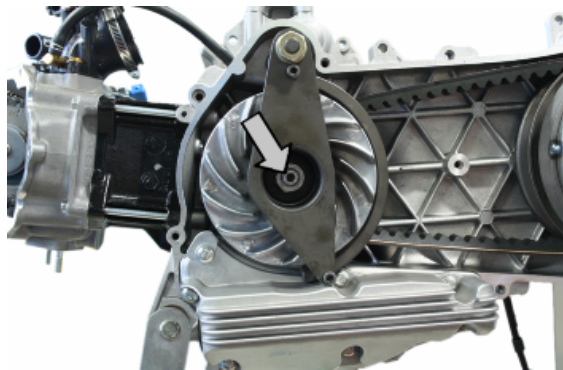

**Specific tooling**

**020626Y008 Driving pulley lock wrench**

- Remove nut «1», Belleville spring «2», and washer «3».

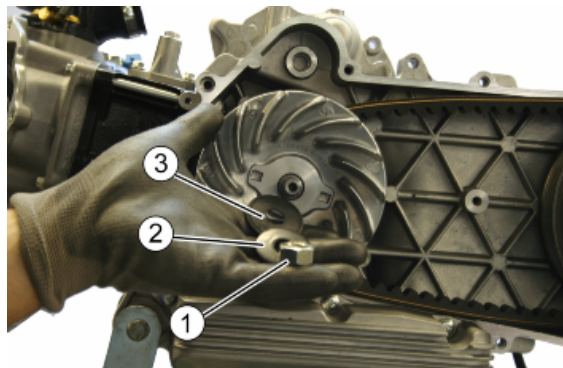

- Remove the stationary driving half-pulley.

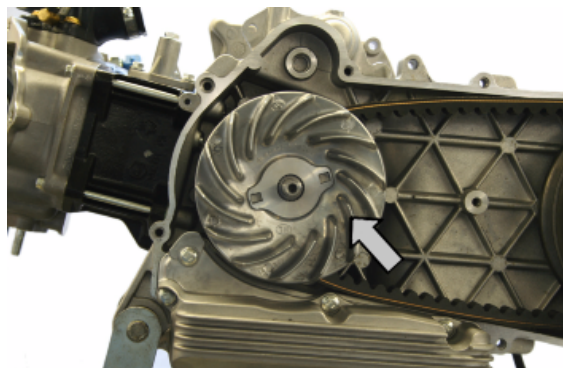



- Detach the drive belt from the crankshaft, remove the sliding bushing and the entire roller housing.

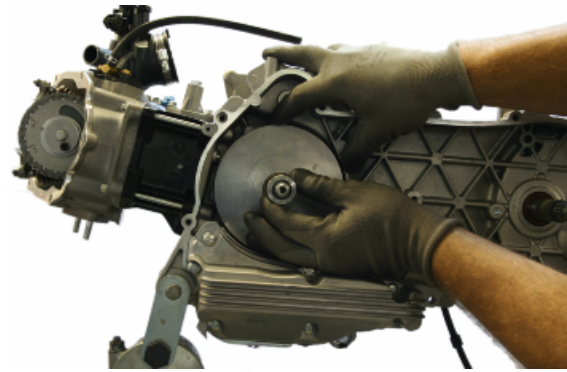

### Inspecting the rollers case

- Check that the internal bushing shown in the figure is not abnormally worn and measure inner diameter A.
- Measure outer diameter B of the pulley sliding bushing shown in the figure.
- Check that the rollers are not damaged or worn.
- Check the guide shoes for the variator back-plate are not worn.
- Check the wear of the roller housings and of the belt faying surfaces on both pulley halves.
- Check that stationary driving pulley does not show signs of abnormal wear on the grooved edge and on the surface in contact with the belt.
- Check that the O-ring is not pushed out of shape.



**CAUTION**

DO NOT LUBRICATE OR CLEAN SINTERED BUSHINGS

**Characteristic**

**movable driving half-pulley bushing: Standard Diameter**

26.000 - 26.021 mm

**movable driving half-pulley bushing: Maximum allowable diameter**

Ø 26.12 mm

**Sliding bushing: Standard Diameter**

Ø 25.959 ÷ 25.98 mm

**Sliding bushing: Minimum admissible diameter**

Ø 25.95 mm

**Roller: Standard diameter**

Ø 19.5 - 20.1 mm

**Roller: Minimum admissible weight**

5.4 ± 0.15 g

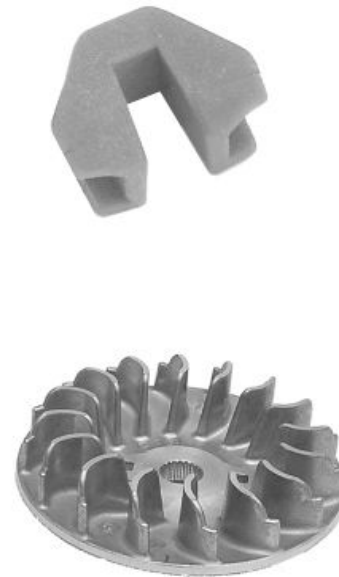

---

## Refitting the driving pulley

- Preassemble the movable half-pulley with the roller contrast plate by putting the rollers in their housings with the larger support surface touching the pulley according to the direction of rotation.
- Check that the roller contact plate does not have flaws and is not damaged on the grooved edge.
- Mount the complete bushing unit on the crankshaft.
- Fit the driven pulley/Clutch/belt unit on the engine.

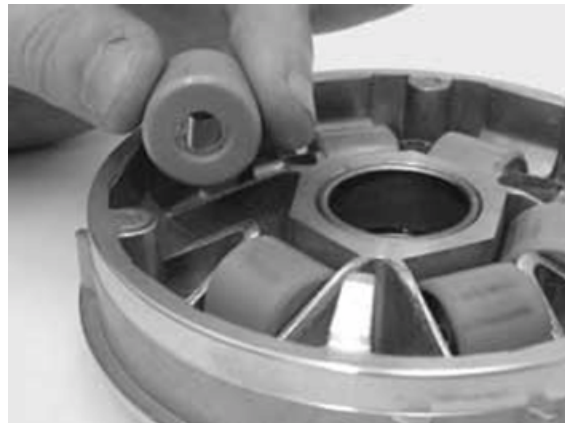

- 
- Fit the steel shim in contact with the bushing and the stationary drive pulley.
  - Install the appropriate tool as described in the removal phase.
  - Tighten the nut with washer to the prescribed torque.

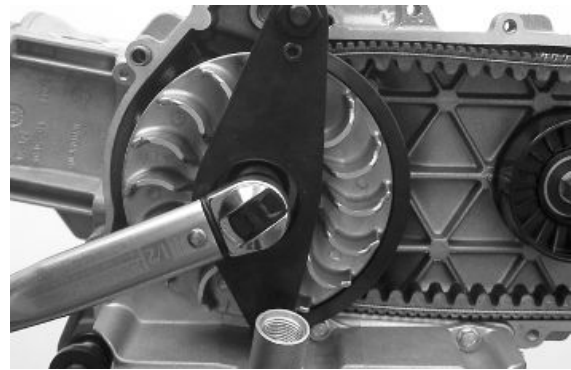
**Specific tooling****020626Y008 Driving pulley lock wrench****Locking torques (N\*m)****Drive pulley nut 75 - 83**

---

**Refitting the transmission cover**

- Check that there are two alignment dowels and that the sealing gasket for the oil sump on the transmission cover is adequately fitted.
- Refit the cover and tighten the «12» screws to the specified torque.
- Refit the steel washer and the driven pulley nut.
- Tighten the nut to the prescribed torque using the lock wrench and the torque wrench tools.
- Refit the plastic cover.

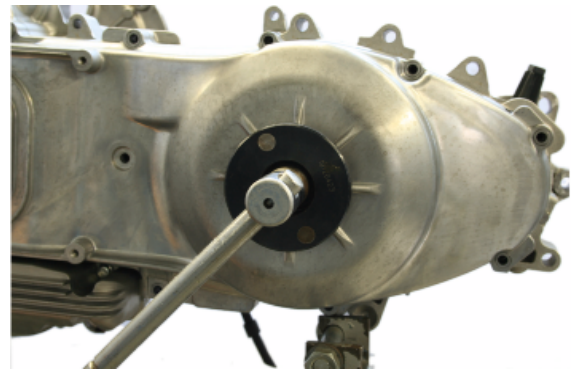
**Specific tooling****020423Y Driven pulley lock wrench****Locking torques (N\*m)****Transmission cover screws 11 to 13 Driven pulley shaft nut 54 ÷ 60**

---

**End gear**

---

## Removing the hub cover

- Empty the reduction oil through the drain screw «1».
- Undo the six screws «2», and the screw «3».

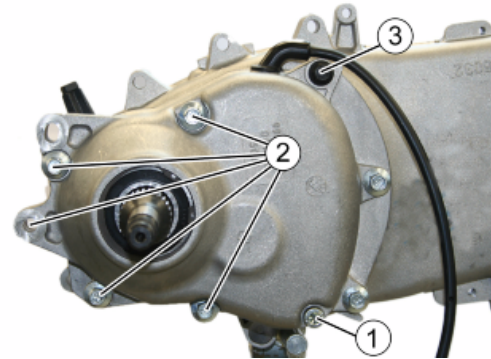

- Remove gasket «4» and make sure that alignment dowels «5» are adequately positioned.

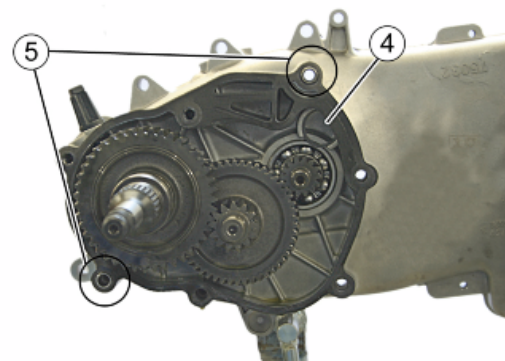

## Removing the wheel axle

- Remove the wheel axis complete with gear.
- Remove the intermediate gear.

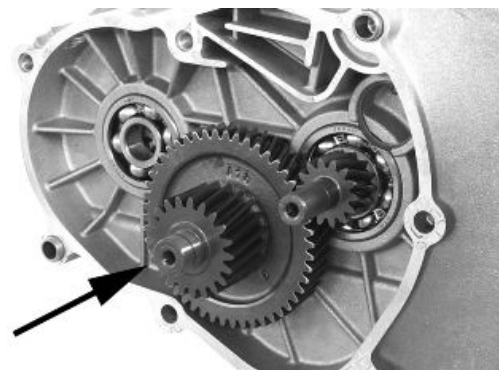
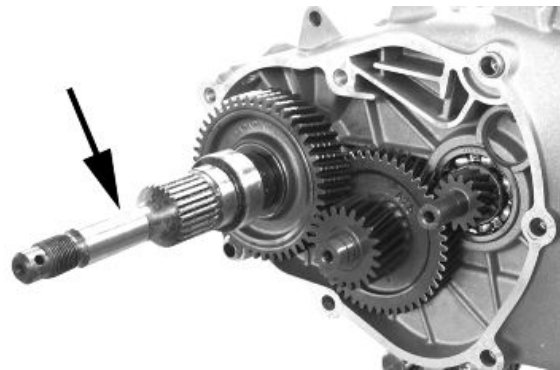

---

## Removing the hub bearings

---

- Check the state of the bearings being examined (wear, clearance and noisiness). If faults are detected, do the following.
- Use the specific bearing extractor to remove the three 15 mm bearings (2 in the crankcase and 1 in the hub cover).

### Specific tooling

**001467Y013 Calliper to extract  $\varnothing$  15-mm bearings**



---

## Removing the wheel axle bearings

---

- Take out the clip on the outside of the hub cover.
  - Support the hub cover and expel the bearing.
- By means of the appropriate tools, remove the oil guard as in the figure.

### Specific tooling

**020376Y Adaptor handle**

**020477Y 37 mm adaptor**

**020483Y 30-mm guide**

**020359Y 42x47-mm Adaptor**

**020489Y Hub cover support stud bolt kit**



## Removing the driven pulley shaft bearing

- Extract the driven pulley shaft from its bearing.
- Remove the oil seal using a screwdriver and be careful not to damage the seat.

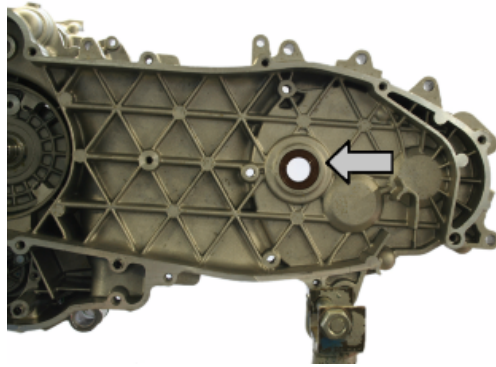

- Remove the Seeger ring indicated.

### Specific tooling

020376Y Adaptor handle

020375Y 28 x 30 mm adaptor

020363Y 20-mm guide

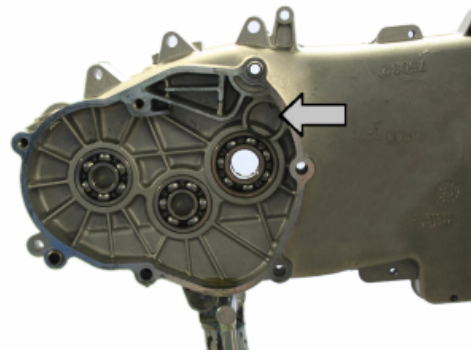

- Remove the driven pulley shaft bearing using the modular punch.

### Specific tooling

020376Y Adaptor handle

020375Y 28 x 30 mm adaptor

020363Y 20-mm guide

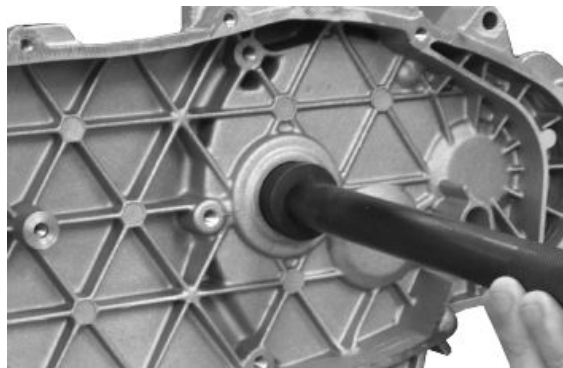

## Inspecting the hub shaft

- Check that the 3 shafts exhibit no wear or deformation on the grooved surfaces, at the bearings and at the oil seals.
- In case of faults, replace the damaged parts.

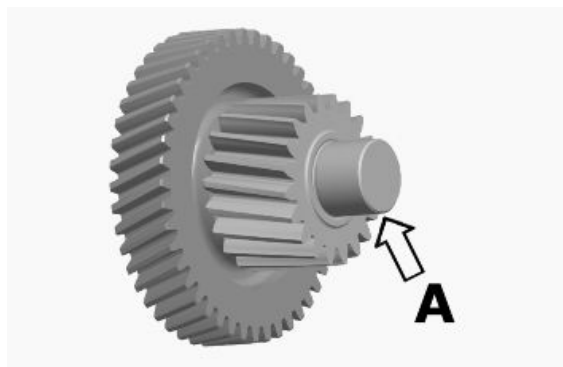

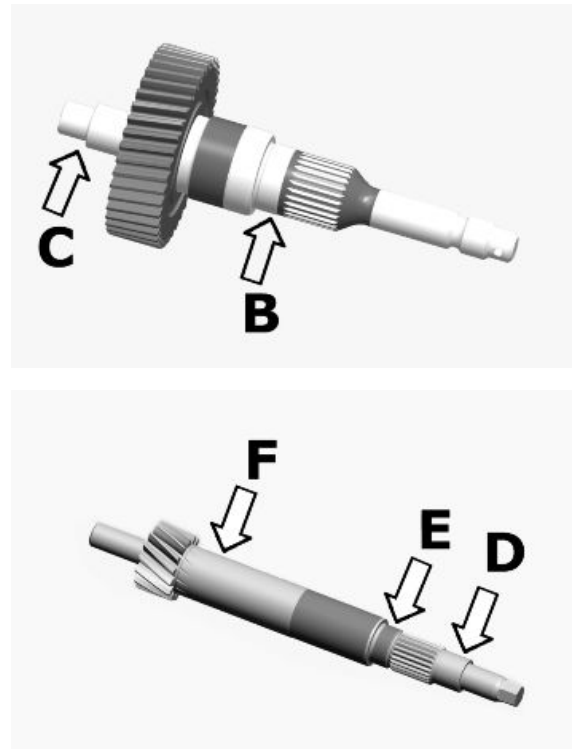

### Characteristic

#### Connection diameter for countershaft:

A =  $\varnothing 15 - 0.01 - 0.02$  mm

#### Connection diameter for wheel shaft:

B =  $\varnothing 25 - 0.020 - 0.035$  mm

C = diameter 15 - 0.01 - 0.02 mm

#### Bearing diameter for driven pulley shaft:

D =  $\varnothing 15 - 0.01 - 0.02$  mm

E =  $19.8 \pm 0.1$

F =  $\varnothing 20 - 0.01 - 0.02$  mm

---

### Inspecting the hub cover

- Check that the fitting surface is not dented or distorted.
  - Check the bearing bearings.
  - In case of faults, replace the damaged components.
-

## Refitting the wheel axle bearing

- Support the hub cover on a wooden surface.
- Heat the crankcase cover with the specific heat gun.
- Fit the wheel shaft bearing with a modular punch as shown in the figure.
- Fit the Seeger ring.
- Fit the oil guard with seal lip towards the inside of the hub and place it flush with the internal surface by means of the appropriate tool used from the 52-mm side.

The 52-mm side of the adapter must be turned towards the bearing.

### Specific tooling

**020376Y Adaptor handle**

**020360Y 52x55-mm Adaptor**

**020483Y 30-mm guide**





## Refitting the hub cover bearings

In order to fit the hub box bearings, the engine crankcase and the cover must be heated with the special heat gun.

- The three 15-mm bearings must be fitted using the appropriate tools:
- The 42-mm side of the adaptor must be turned towards the bearing.

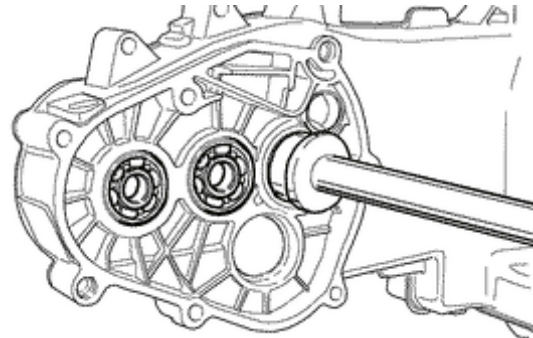

### Specific tooling

020150Y Air heater mounting

020151Y Air heater

020376Y Adaptor handle

020359Y 42x47-mm Adaptor

020412Y 15-mm guide



**N.B.**

**TO FIT THE BEARING ON THE COVER, ADEQUATELY SUPPORT THE COVER WITH THE STUD BOLT KIT.**

- Refit the driven pulley shaft bearing with a modular punch as shown in the figure.

**N.B.**

**IF THE BEARING HAS AN ASYMMETRICAL BALL RETAINER, PLACE IT SO THAT THE BALLS ARE VISIBLE FROM THE HUB INNER SIDE.**

### Specific tooling

020376Y Adaptor handle

020359Y 42x47-mm Adaptor

020363Y 20-mm guide



**N.B.**

**WHEN FITTING THE BEARINGS ON THE ENGINE CRANKCASE, SUPPORT THE CRANKCASE PREFERABLY ON A SURFACE TO ALLOW THE BEARINGS TO BE DRIVEN VERTICALLY.**

- Refit the Seeger ring with the opening facing the bearing and fit a new oil seal flush with the crankcase from the pulley side.

---

## Refitting the hub bearings

- Install the three shafts in the engine crankcase as shown in the figure.



---

## Refitting the hub cover

- Fit a new gasket together with the alignment dowels.
- Seal the gasket of the breather pipe using black silicone sealant.
- Fit the gearbox cover, making sure the breather pipe is in the correct position.
- Position the shorter screw that can also be recognised from the different colour as shown in the figure.
- Fix the breather tube support by means of the lower screw.
- Fit the remaining screws and tighten the seven screws to the prescribed torque.

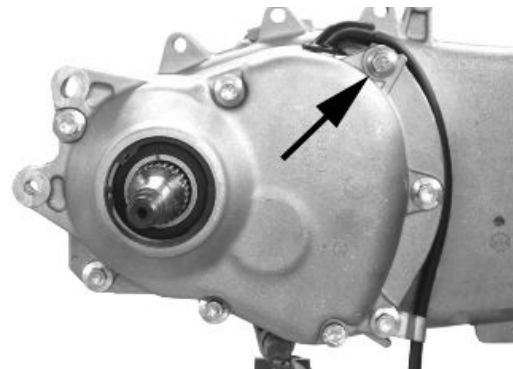
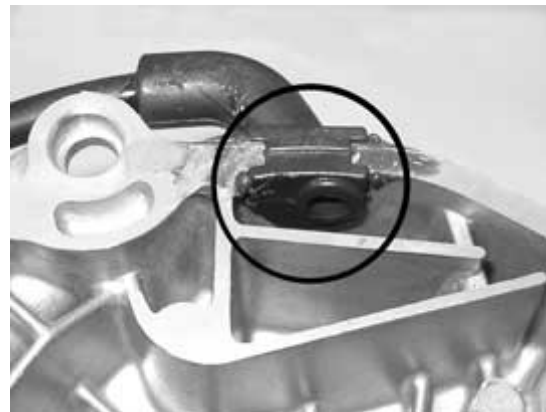

### Locking torques (N\*m)

Hub cover fixing screws 24 to 27 Hub oil drain screws 15 to 17

---

## Flywheel cover

---

---

**Removing the hub cover**

---

- Remove the clamps fastening the water pipes on the pump cover.
- Detach the pipes from the pump cover.

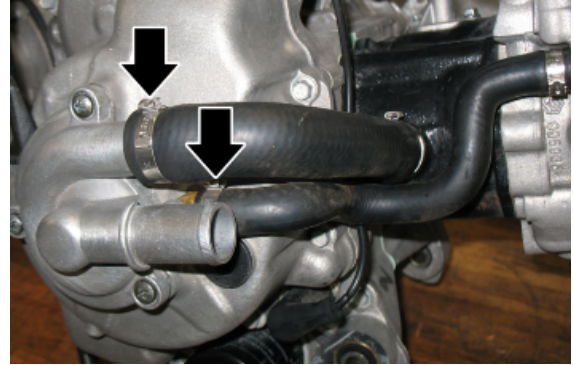

- 
- Unscrew the ten screws fastening the flywheel, retrieving the indicated plate.
  - Disconnect the electric connector from the minimum oil pressure switch.

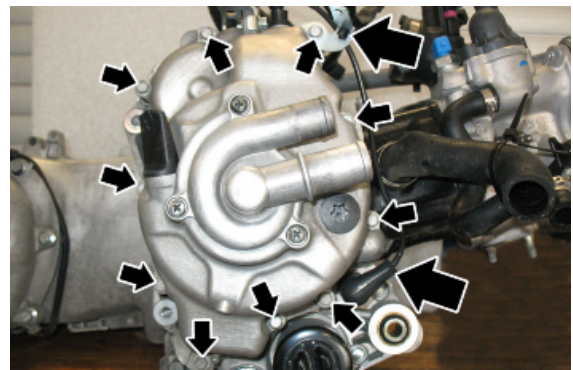

- 
- Remove the flywheel cover.

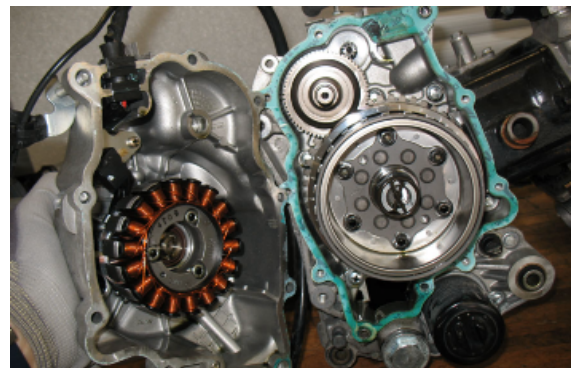

- 
- Remove the gasket and be careful with the two alignment dowels.

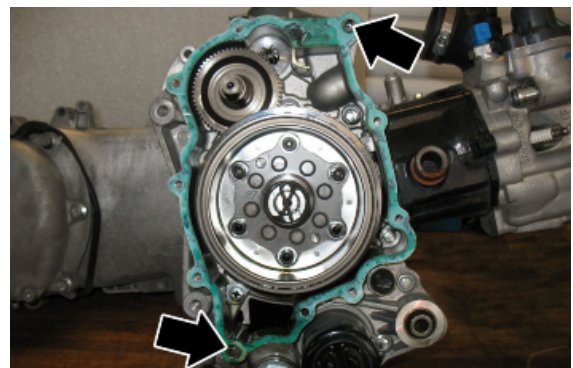

---

## Removing the stator

- Remove the two pickup screws and the screw holding the wiring support and the three stator clamping screws shown in the figure.
- Remove the stator and its wiring.

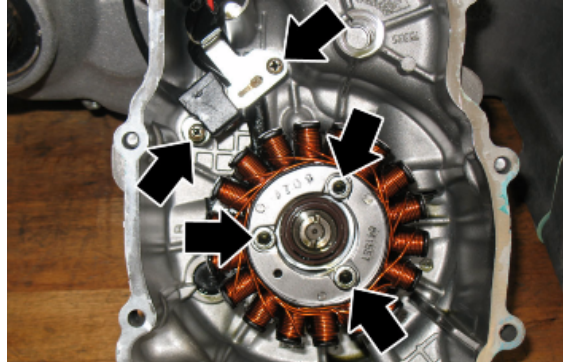

---

## Refitting the stator

- Refit the stator and flywheel carrying out the removal procedure in reverse, tightening the retainers to the specified torque.

### Locking torques (N\*m)

**Stator fixing screws 8 to 10 Pickup fixing screws 3 to 4**

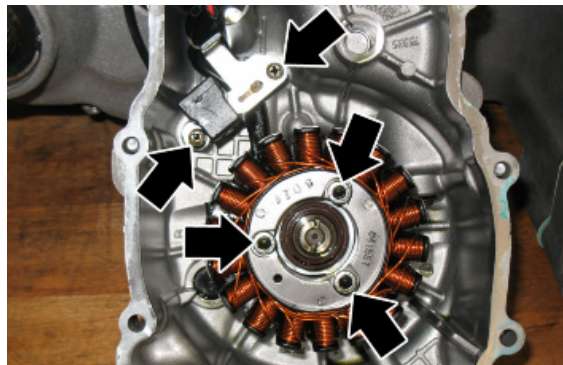

---

## Refitting the flywheel cover

- Fit the gasket and be careful with the two alignment dowels.

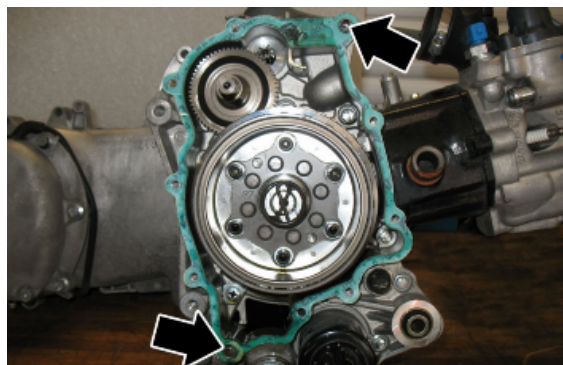

- Position the spline clip on the crankshaft and orient the end as shown in the figure.

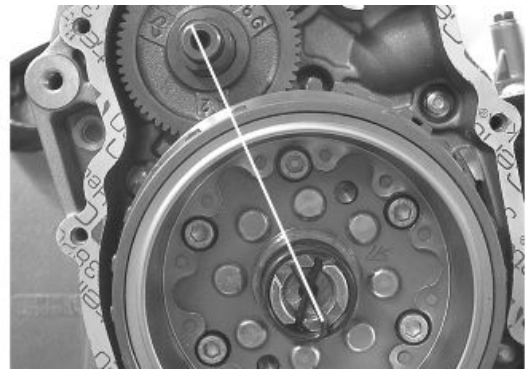

- Orient the water pump shaft with reference to the transmission gear seat as shown in the picture.

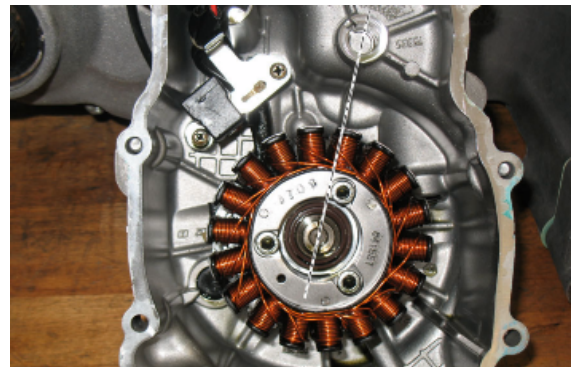

- Fit the flywheel cover complete with pump, ensuring that the alternator cable grommet is fitted correctly.
- Tighten the ten screws fastening the flywheel cover, ensuring that the indicated plate is positioned correctly.
- Reconnect the electric connector on the minimum oil pressure switch.

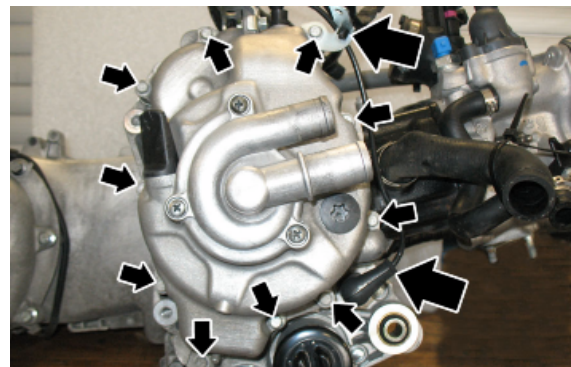

- Fit the water pipes onto the unions on the pump cover and tighten the clamps.

**Locking torques (N\*m)**  
**Flywheel cover screw 11 to 13**

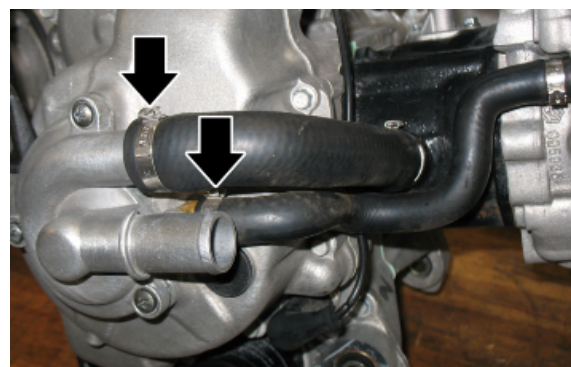

## Flywheel and starting

## Removing the starter motor

- Remove the two screws indicated in the figure
- Take the starter motor out of its seat

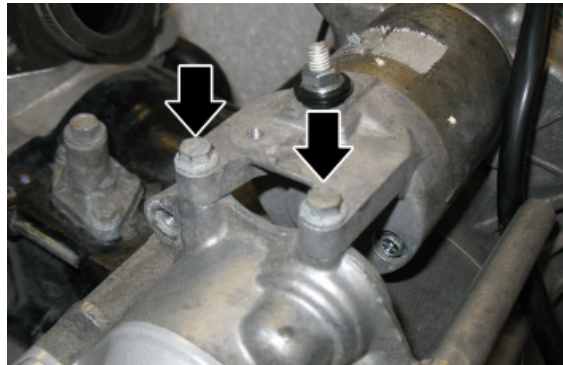

## Removing the flywheel magneto

- Remove the screw and the plate of the starting sprocket.

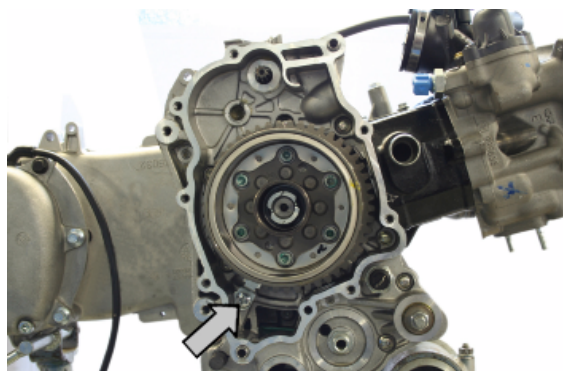

- Fit the specific tool, screw the guide bushing to the flywheel, insert the flywheel stop tool as shown in the picture.

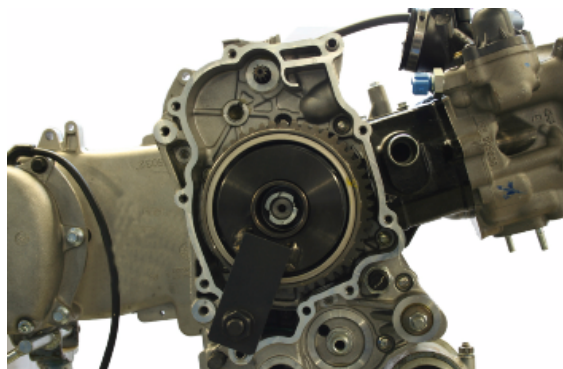

### Specific tooling

**020627Y Flywheel lock wrench**

- Undo the flywheel screw and remove the washer.
- Manually screw the nut without washer, being careful not to leave the first threads uncovered.

### CAUTION



SCREWING UP THE NUT WITHOUT WASHER HELPS PROTECT THE THREAD AGAINST THE STRAIN EXERTED BY THE EXTRACTOR AND ALSO PREVENTS DROPPING THE FLYWHEEL ACCIDENTALLY UPON EXTRACTING IT. POTENTIAL DROPS MAY DAMAGE THE CERAMIC INSERTS.

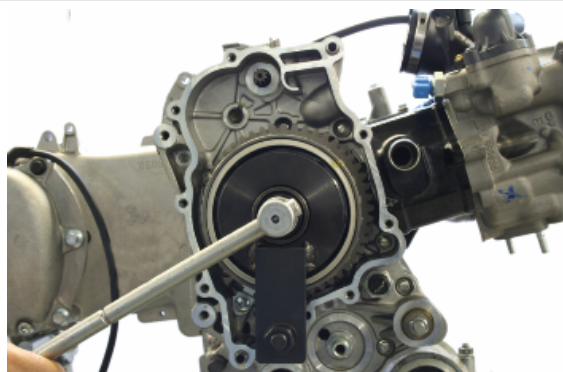

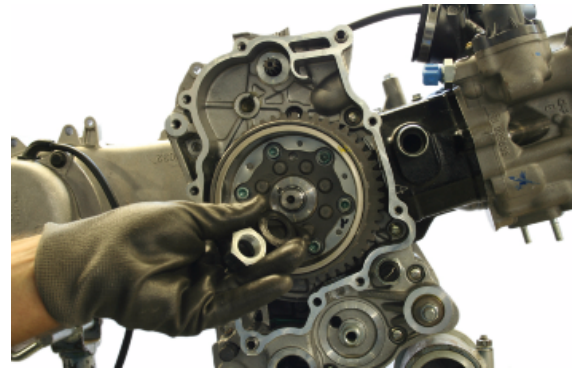

- Insert the extractor.

**Specific tooling**

**020467Y Flywheel extractor**

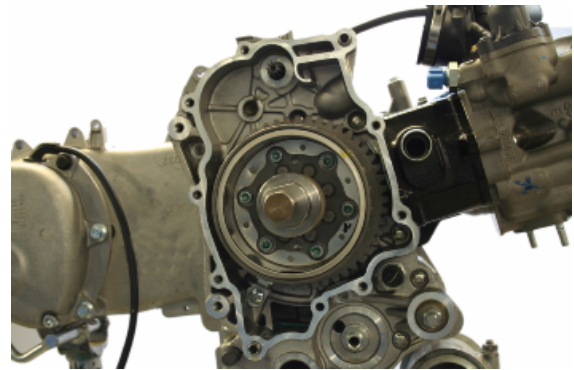

- Act on the extractor to remove the flywheel together with the starting sprocket.

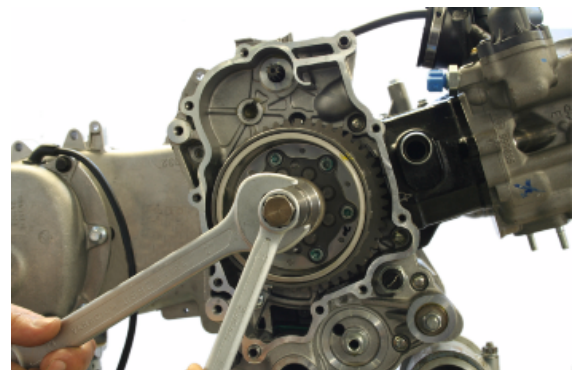
**Inspecting the flywheel components**

- Check the integrity of the internal plastic parts of the flywheel and the Pick-up control plate.

**Starter gear rim****See also**

[Removing the flywheel magneto](#)

## Intermediate gear

- Remove the flywheel cover.
- Remove the intermediate gear and take it out of its housing.

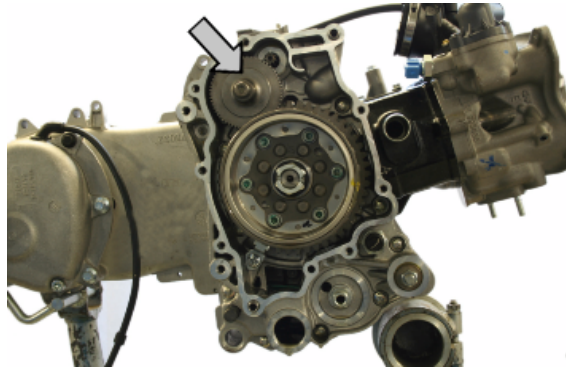

## Refitting the free wheel

- Make sure the freewheel faying surfaces are in good condition.
- Thoroughly clean the free wheel to remove LOCTITE residue.
- Degrease the threading of the holes in the free wheel and the clamping screws.
- Apply the recommended product to the end of the screws.

### Recommended products

#### Loctite 243 Medium strength threadlock

Medium Loctite 243 threadlock

- Fit the freewheel on the magneto flywheel making sure that the ground side is in contact with the flywheel itself, i.e. with wheel Seeger ring visible.
- Lock the six clamping screws in criss-cross fashion to the prescribed torque.



### Locking torques (N\*m)

#### Screw fixing freewheel to flywheel 13 - 15

- Oil the free wheel "rollers".





## Refitting the flywheel magneto

- Remove the freewheel retaining plate indicated in the picture
- Remove the transmission gear and the freewheel



- Insert the free wheel on the flywheel as shown in the picture
- Then refit the flywheel with free wheel and transmission gear



- Using the special flywheel lock wrench, tighten up the flywheel fixing nut to the prescribed torque
- Refit the retention plate



### Specific tooling

020627Y Flywheel lock wrench

### Locking torques (N\*m)

Flywheel nut 94 - 102

## Refitting the starter motor

- Fit a new O-ring on the starter motor and lubricate it.
- Fit the starter motor on the crankcase and lock the 2 screws to the prescribed torque.

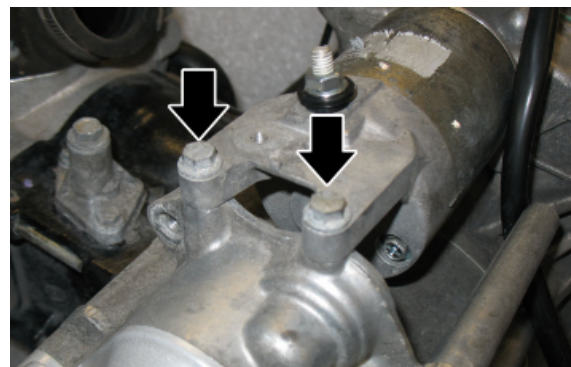

### Locking torques (N\*m)

Starter screws 11 to 13

---

## Cylinder assy. and timing system

---

### Removing the intake manifold

---

- Undo the three screws with an anti-tampering device.

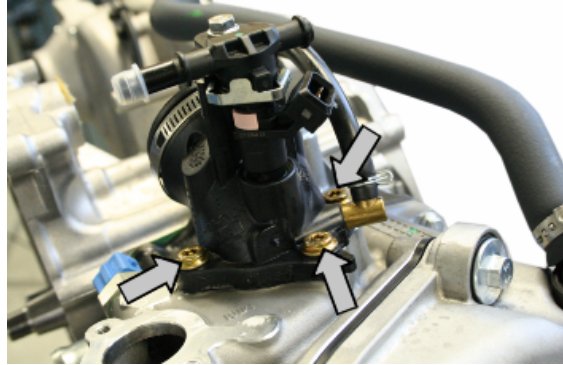

---

### Removing the rocker-arms cover

---

- Remove the five screws shown in the figure.
- Remove the entire head cover.

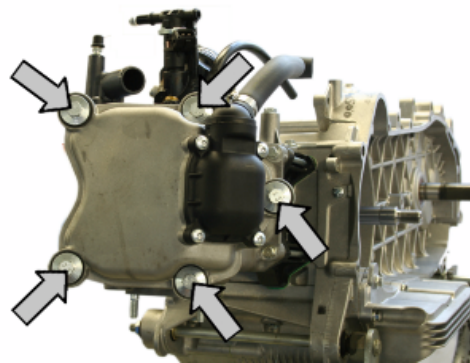

---

### Removing the timing system drive

---

- Remove the oil pump control gear and the pinion separation washer as described in the «Engine/ Lubrication/Oil pump» section.
- Undo the central screw and collect the washer. Undo the two fixing screws to the cylinder and remove the tensioner together with the gasket.

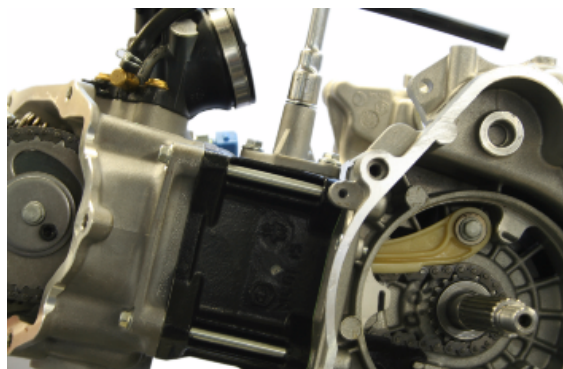

- Undo the two screws indicated.

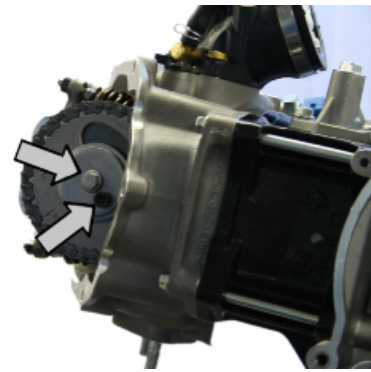

- Detach the timing chain and remove the camshaft control pulley and the corresponding washer.

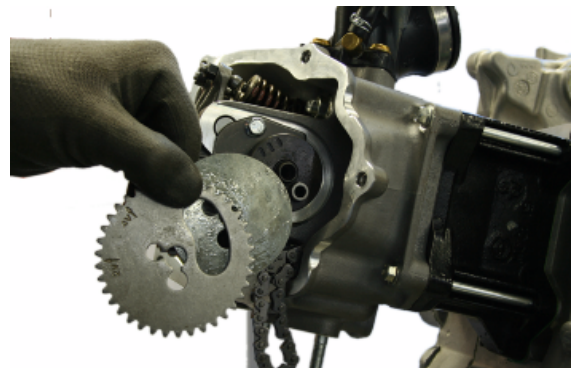

- Remove the screws indicated in the figure, the spacer bar and the tensioner slider.
- Remove the control sprocket wheel and the timing chain.
- As regards the chain guide slider, it may only be removed after the head has been removed.

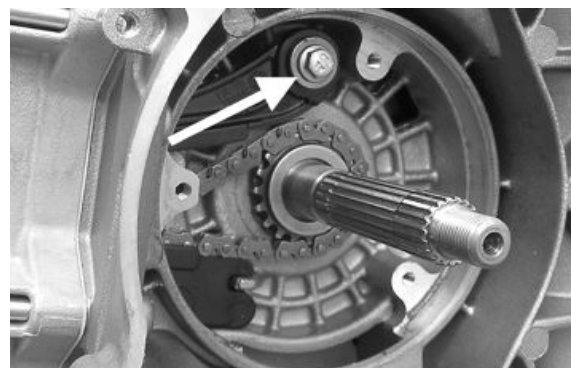

**N.B.**

**IT IS ADVISABLE TO MARK THE CHAIN IN ORDER TO ENSURE THAT THE INITIAL DIRECTION OF ROTATION IS MAINTAINED.**

## Removing the cam shaft

- Undo the two indicated fixing screws to the cylinder and remove the fixing plate.

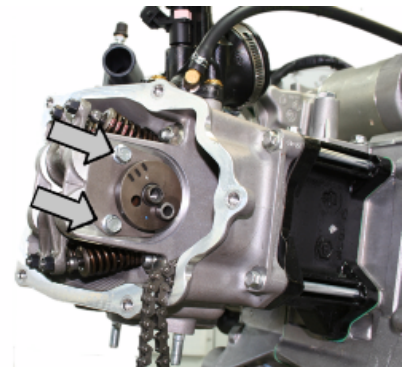



- Remove the camshaft.



- Acting on flywheel-side holes, push and slide off the rocking lever pins.

**N.B.**

**IF NEEDED, THE HEAD MAY BE REMOVED WITH THE CAMSHAFT, ROCKER PINS AND FIXING BRACKET. THE HEAD CAN ALSO BE REMOVED WITHOUT REMOVING THE CHAIN AND THE CRANKSHAFT CHAIN TENSIONER.**



## Removing the cylinder head

- Undo the two screws «1» fixing the head to the transmission-side crankcase half.
- Unscrew the four nuts «2» by loosening them in two or three stages and in a crossed sequence.

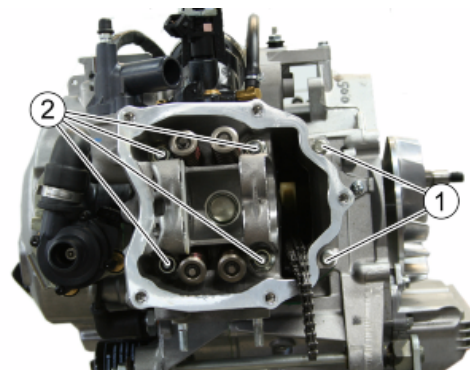

- Remove the head.

**N.B.**

IF NEEDED, THE HEAD MAY BE REMOVED WITH THE CAMSHAFT, ROCKER PINS AND FIXING BRACKET. THE HEAD CAN ALSO BE REMOVED WITHOUT REMOVING THE CHAIN AND THE CRANKSHAFT CHAIN TENSIONER.

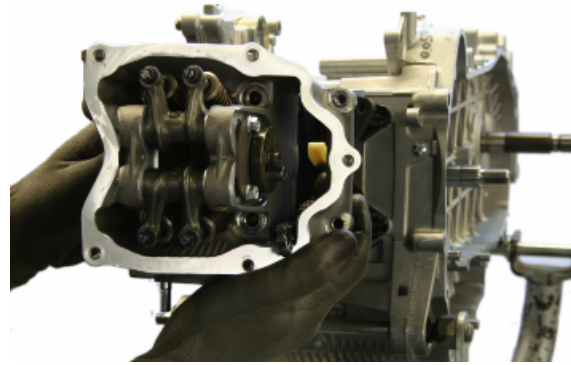

- Remove the gasket.



## Removing the valves

- Using the appropriate tool fitted with an adaptor, remove the cotters, caps, springs and valves.
- Remove the oil guards with the appropriate tool.
- Remove the lower spring supports.

**CAUTION**

REPLACE THE VALVES IN SUCH A WAY AS TO RECOGNISE THEIR ORIGINAL POSITION ON THE HEAD.

### Specific tooling

020382Y011 adapter for valve removal tool

020382Y Valve cotters equipped with part 012 removal tool

020431Y Valve oil seal extractor



## Removing the cylinder - piston assy.

- Remove the chain guide slider; be careful with the two alignment dowels and remove the cylinder.

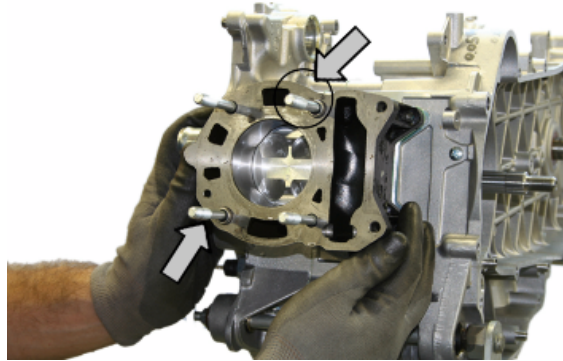

- Remove the base gasket; be careful with the two centring dowels and the dowel pin.

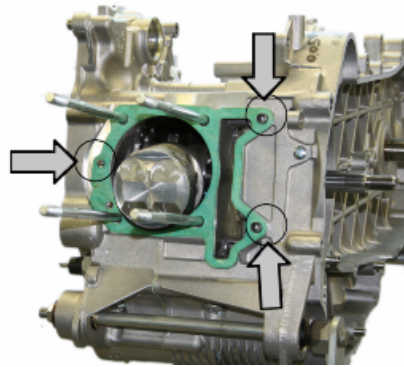

- Remove the sealing rings, the pin and remove the piston.

### CAUTION

TO PREVENT DAMAGING THE PISTON, SUPPORT IT WHILE REMOVING THE CYLINDER.

### N.B.

BE CAREFUL NOT TO DAMAGE THE SEALING RINGS DURING REMOVAL.



## Inspecting the small end

### N.B.

TO MEASURE WEAR LIMITS AND COUPLING CLEARANCES, SEE THE SPECIFICATIONS CHAPTER.

### See also

[Crankcase - crankshaft - connecting rod](#)

## Inspecting the wrist pin

### N.B.

TO MEASURE WEAR LIMITS AND COUPLING CLEARANCES, SEE THE SPECIFICATIONS CHAPTER.

### See also

[Cylinder - piston assy.](#)

## Inspecting the piston

**N.B.**

**TO MEASURE WEAR LIMITS AND COUPLING CLEARANCES, SEE THE SPECIFICATIONS CHAPTER.**

**See also**

[Cylinder - piston assy.](#)

## Inspecting the piston rings

**N.B.**

**TO MEASURE WEAR LIMITS AND COUPLING CLEARANCES, SEE THE SPECIFICATIONS CHAPTER.**

**See also**

[Piston rings](#)

## Removing the piston

- Install piston and wrist pin onto the connecting rod, aligning the piston arrow the arrow facing towards the exhaust.

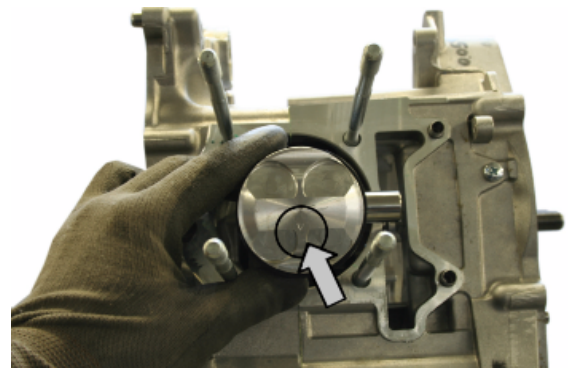

- Fit the pin retainer ring onto the appropriate tool
- With opening in the position indicated on the tool
- S = left
- D= right
- Place the wrist pin retainer ring into position using a punch
- Fit the wrist pin retainer ring using the plug as shown in the figure



**N.B.**

**THE TOOL FOR INSTALLING THE RETAINER RINGS MUST BE USED MANUALLY.**

**CAUTION**

**USING A HAMMER MIGHT DAMAGE THE STOPS' HOUSING.**

### Specific tooling

**020430Y Pin lock fitting tool**

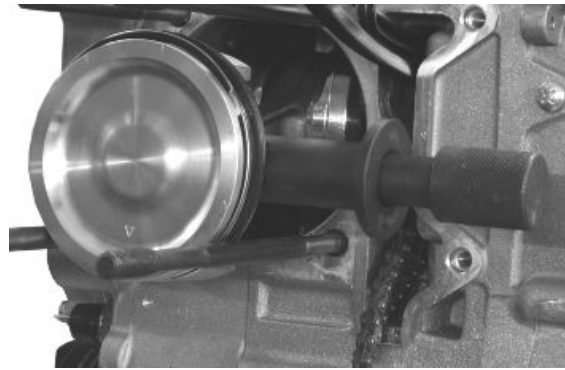

## Choosing the gasket

- Provisionally fit the piston into the cylinder, without any base gasket.
- Install a dial gauge on the special tool using the short union, as shown in the figure.

### Specific tooling

#### 020475Y Piston position checking tool

- Using an abutment plane, reset the dial gauge with a preload of a few millimetres.
- Finally fix the dial gauge.
- Check the perfect sliding of the feeler pin.
- Install the tool on the cylinder without changing the dial gauge position.
- Lock the tool using the original head fixing nuts.
- Rotate the crankshaft up to the TDC (the inversion point of the dial gauge rotation)
- Measure the deviation from the reset value.

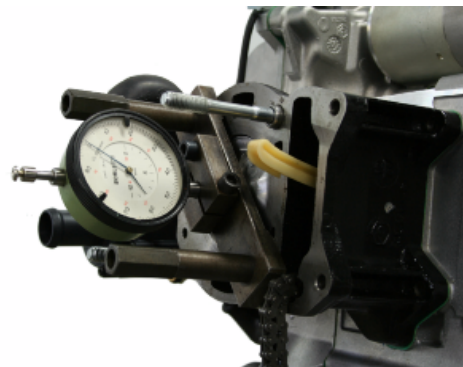

- By means of the table, see the Specifications chapter identify the cylinder base gasket thickness to be used for refitting. Correctly identify the cylinder base gasket thickness to keep the correct compression ratio.
- Remove the special tool and the cylinder.

**N.B.**

**IF DEVIATIONS (OR RECESSES OR PROJECTIONS) CLOSE TO THE CHANGE OF CATEGORY ARE MEASURED, REPEAT THE MEASUREMENT AT THE OPPOSED SIDE. TO DO SO, REPEAT THE TOOL INSTALLATION BY INVERTING ITS POSITION.**



**See also**[Slot packing system](#)**Refitting the piston rings**

- Pistons (like cylinders) are supplied in 4 categories: A, B, C and D, and must be fitted so that the reference arrow faces the exhaust duct. The letter is found at the centre of the piston.
- Fit the sealing rings with the word TOP or the identification letter facing upwards. In any case, the step must be facing opposite the piston crown.
- Sealing rings are manufactured with a cylinder contact conical cross-section and piston gaps must be offset by 120° in order to obtain a better bedding.
- Lubricate rings with engine oil when fitting them.

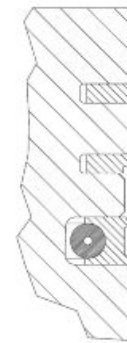
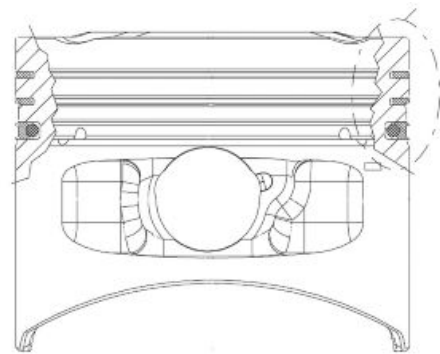
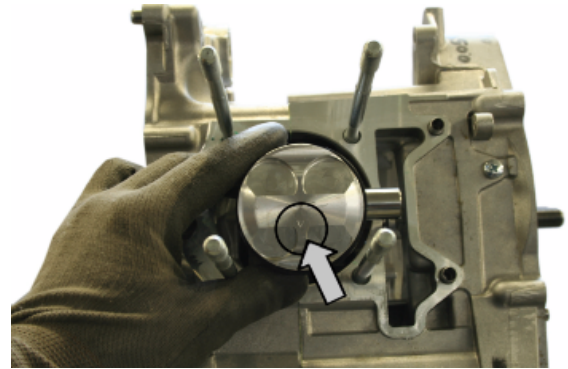
**Refitting the cylinder****N.B.****BEFORE FITTING THE CYLINDER, CAREFULLY BLOW OUT THE LUBRICATION DUCT AND OIL THE CYLINDER BARREL.**

- Check the position of the centring dowels and dowel pin and fit a gasket with a thickness previously determined.

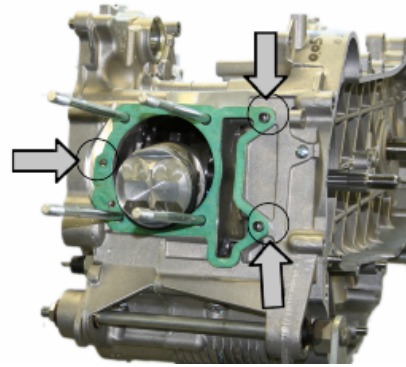

- Using the specific tool fit the cylinder paying attention that the chain does not remain in the timing system compartment.

### Specific tooling

020426Y Piston fitting fork

020393Y Piston assembly band

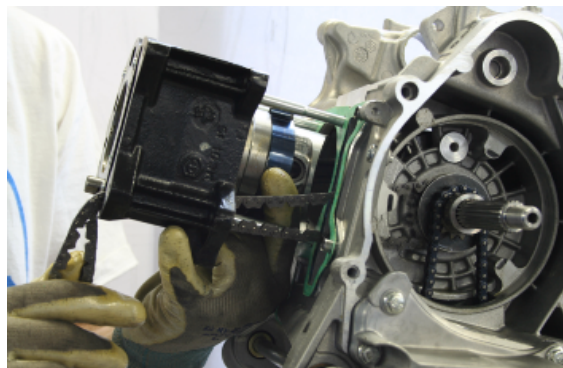

## Inspecting the cylinder head

N.B.

**TO MEASURE WEAR LIMITS AND COUPLING CLEARANCES, SEE THE SPECIFICATIONS CHAPTER.**

**See also**

[Cylinder Head](#)

## Inspecting the timing system components

- Check that the guide slider and the tensioner slider are not worn out.
- Ensure that the camshaft control pulley chain assembly and the sprocket wheel are not worn.
- If you detect wear, replace the parts or, if the chain, sprocket wheel and pulley are worn, replace the whole unit.
- Remove the centre screw with the washer and the tensioner spring. Check that the one-way mechanism is not worn.
- Check the condition of the tensioner spring.
- If examples of wear are found, replace the whole unit.

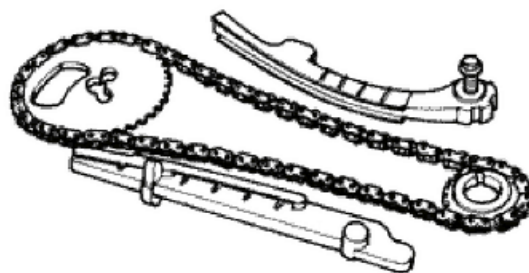

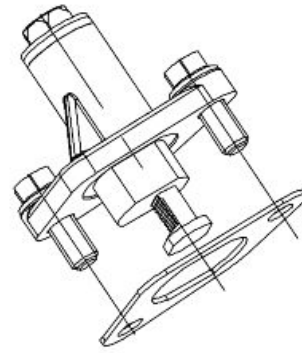

---

## Inspecting the valve sealings

**N.B.**

**TO MEASURE WEAR LIMITS AND COUPLING CLEARANCES, SEE THE SPECIFICATIONS CHAPTER.**

**See also**

[Cylinder Head](#)

---

## Inspecting the valves

**N.B.**

**TO MEASURE WEAR LIMITS AND COUPLING CLEARANCES, SEE THE SPECIFICATIONS CHAPTER.**

**See also**

[Cylinder Head](#)

---

## Inspecting the springs and half-cones

- Check that the upper and lower supporting spring washers, the cotters and the oil seal show exhibit no signs of abnormal wear. Replace a component when worn.



**N.B.**

**TO MEASURE WEAR LIMITS AND COUPLING CLEARANCES, SEE THE SPECIFICATIONS CHAPTER.**

**See also**

[Cylinder Head](#)

---

---

## Refitting the valves

---

- Lubricate the valve guides with engine oil.
- Place the valve spring supports on the head.
- Using the special punch, fit the four valve seal rings.
- Fit the valves, the springs and the caps. Using the appropriate tool with adapter, compress the springs and insert the cotters in their seats.

**N.B.**

**DO NOT CHANGE THE VALVE FITTING POSITION. FIT THE VALVE SPRINGS WITH THE REFERENCE COLOUR ON COTTER SIDE (TURNS WITH GREATER PITCH).**

### Specific tooling

**020306Y Punch for assembling valve seal rings**

**020382Y011 adapter for valve removal tool**

**020382Y Tool to extract valve cotters**



---

## Inspecting the cam shaft

**N.B.**

**TO MEASURE WEAR LIMITS AND COUPLING CLEARANCES, SEE THE SPECIFICATIONS CHAPTER.**

**See also**

[Cylinder Head](#)

---

## Refitting the head and timing system components

---

Assemble the timing chain sprocket wheel on the crankshaft with the chamfering facing the insertion side and observing the position of the reference dowel.



- Loop the timing control chain «1» around the crankshaft.
- Fit the guide slider and the tensioner pad «2» on the head side.
- Fit spacer «5» with fixing screw «6».
- Tighten the screws to the prescribed torque.

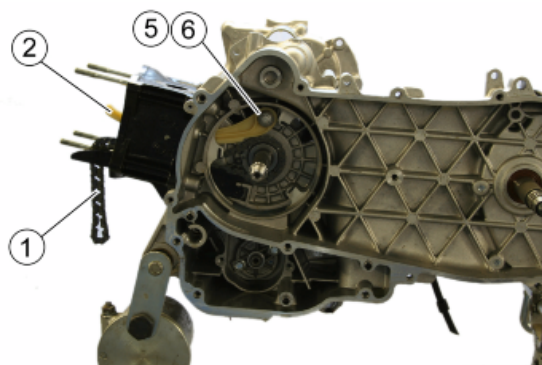

**Locking torques (N\*m)**

**Slider screw 10 - 14 Nm**

- Fit the head gasket and check that the alignment dowels work properly.
- Insert the head.
- Lubricate the stud bolt threads with engine oil.
- Tighten up the nuts to an initial pre-torque of  $7 \pm 1$  Nm.
- Tighten up the nuts to a second pre-torque of  $10 \pm 1$  Nm
- To carry out the operations described above, follow the tightening sequence in the figure.
- Fit the two screws on the outside of the timing chain side and tighten them to the specified torque.

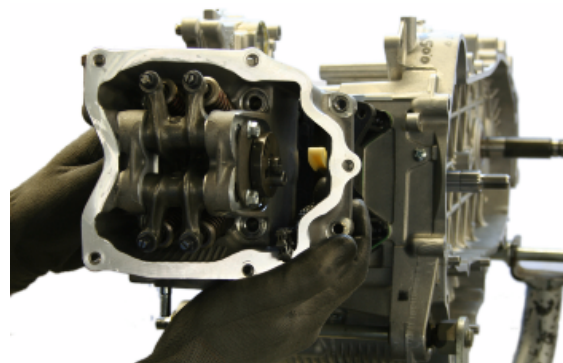
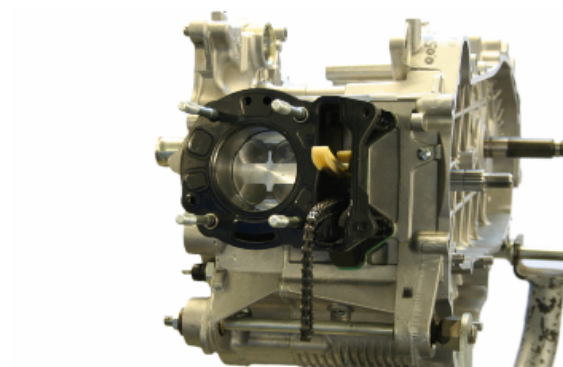

**N.B.**

**BEFORE INSTALLING THE HEAD, MAKE SURE THAT THE LUBRICATION CHANNEL IS CLEAN USING A COMPRESSED AIR JET.**

**Locking torques (N\*m)**

**Timing chain tensioner support screw 11 to 13**

- Fit the pins and rocking levers.
- Lubricate the two rocking levers through the holes at the top.
- Lubricate the 2 bearings and insert the camshaft in the cylinder head with the cams corresponding to the rocking levers.
- Insert the retention plate and tighten the two screws shown in the figure to the prescribed torque.

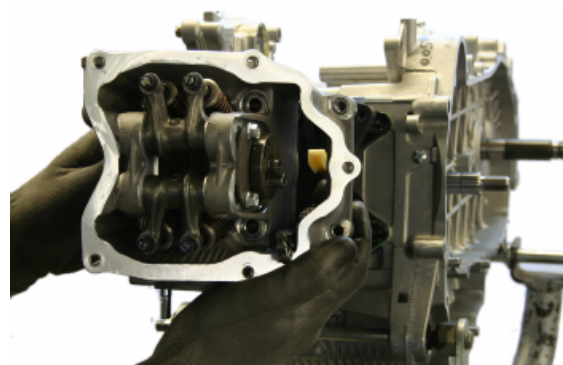

**Locking torques (N\*m)**

**Plate screws 4 - 6 Nm**

Insert the spacer on the cam shaft.

- Rotate the engine so that the piston is at top dead centre, using the reference marks on the flywheel and the crankcase.
- Insert the pulley on the camshaft while keeping the reference 4V in correspondence with the reference mark on the head.
- Holding this position insert the chain on the camshaft control pulley.
- Lock the fixing screws.

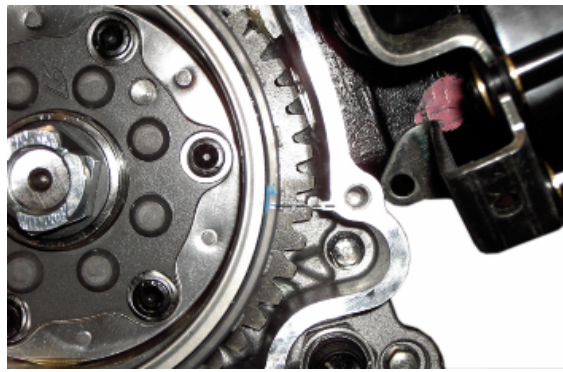

### Locking torques (N\*m)

Counterweight screw 7 to 8.5

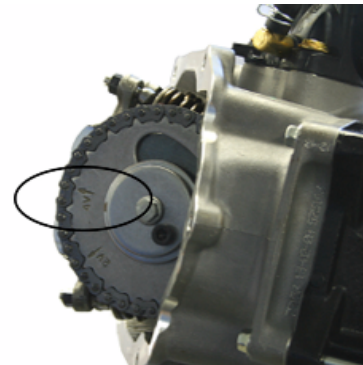

Set the tensioner cursor to the rest position.

- Fit the chain tensioner on the cylinder, using a new gasket, and tight the two screws to the prescribed torque.

Insert the chain tensioning screw, together with the spring and washer, tightening it to the prescribed torque.

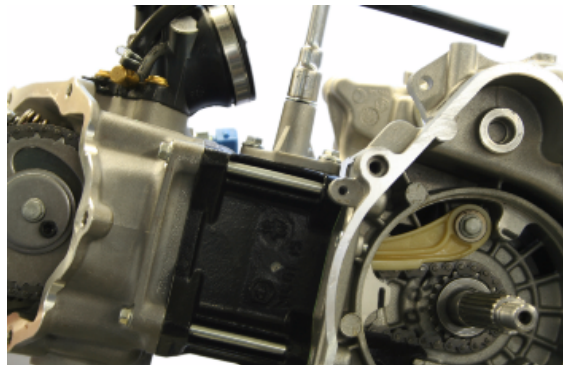

### Locking torques (N\*m)

Tensioner screws 11 to 13 Tensioner cover 5 - 6 Nm

- Check valve clearance.

### Characteristic

#### Valve clearance

Intake: 0.10 mm Exhaust: 0.15 mm

## Refitting the rocker-arms cover

- Refit the cylinder head cover and tighten the 5 clamping screws to the prescribed torque.
- Make sure the gasket is positioned properly.

### Locking torques (N\*m)

Tappet cover screws 5 - 6 Nm

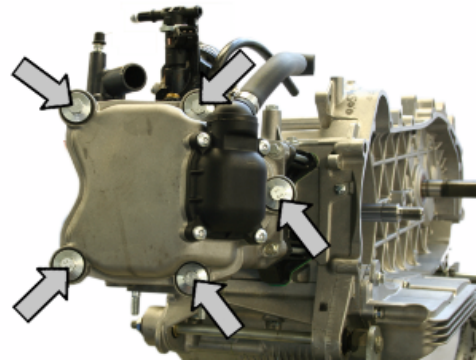

## Refitting the intake manifold

- Fit the intake manifold and do up the three screws.

### Locking torques (N\*m)

Intake manifold screws 11 to 13

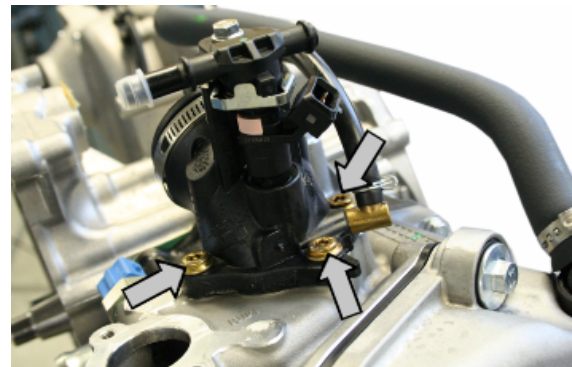

## Crankcase - crankshaft

### Splitting the crankcase halves

#### AXIAL CLEARANCE CHECK

- Before opening the engine crankcase, it is advisable to check the axial clearance of the crankshaft. Use a specific tool to check axial clearance.
- Higher clearances are signs of wear on the crankshaft - crankcase supporting surfaces.

#### Specific tooling

020262Y Crankcase splitting plate

020335Y Magnetic mounting for dial gauge

#### Characteristic

**Axial crankshaft/crankcase clearance: Standard clearance**

0.15 - 0.40 mm (when cold)

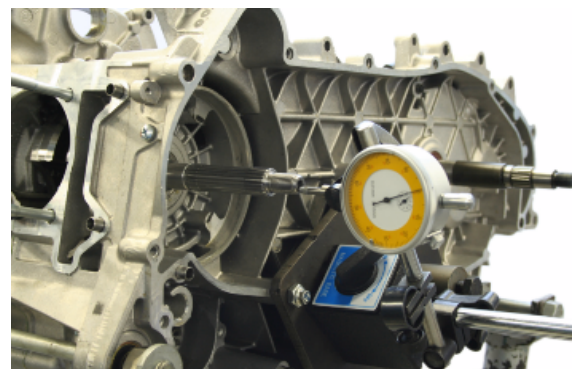

**Axial connecting rod - crankshaft clearance**  
**Standard clearance**

0.20 to 0.50 mm

**CRANKCASE OPENING**

- Undo the ten crankshaft coupling screws.
- Separate the crankcase halves while keeping the crankshaft in one of these two halves.
- Only after the halves have been separated, can the crankshaft be checked.

**CAUTION**

WHILE OPENING THE CRANKCASES AND REMOVING THE CRANKSHAFT, CHECK THAT THE THREADED SHAFT ENDS DO NOT INTERFERE WITH THE MAIN BUSHINGS. FAILURE TO OBSERVE THIS PRECAUTION CAN DAMAGE THE MAIN BUSHINGS.

**CAUTION**

KEEP THE CRANKSHAFT IN ONE OF THE TWO HALVES OF THE CRANKCASE WHEN SEPARATING IT. IF YOU FAIL TO DO THIS, THE CRANKSHAFT MIGHT ACCIDENTALLY FALL.

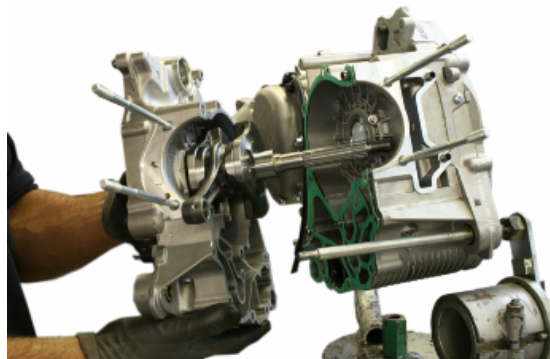
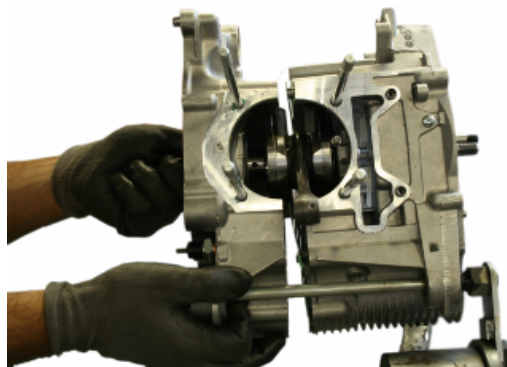
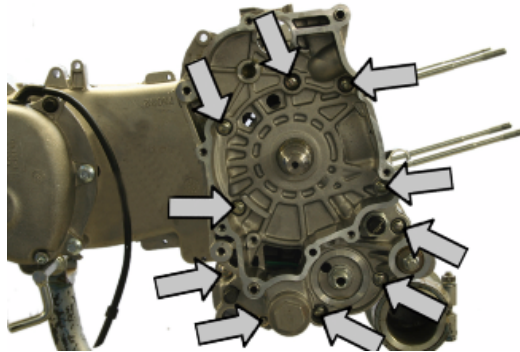

- Remove the crankcase halves gasket and be careful with the two alignment dowels.

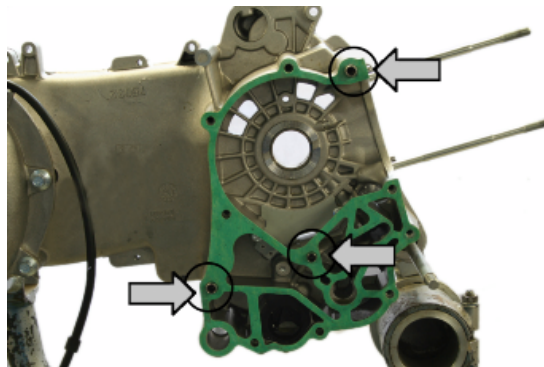



- 
- Unscrew the oil filter fitting if required.

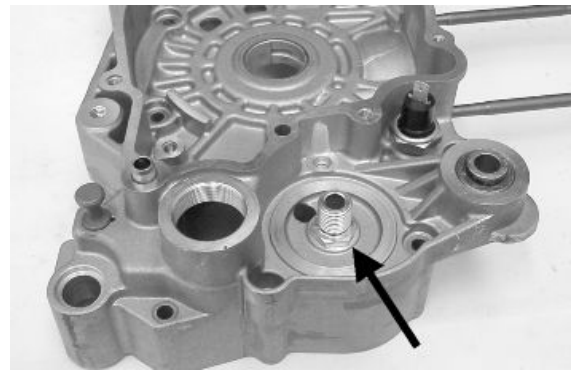

- 
- Once the crankcase halves have been separated, reach and remove the internal bulkhead and the protection bulkhead for the mesh pre-filter.

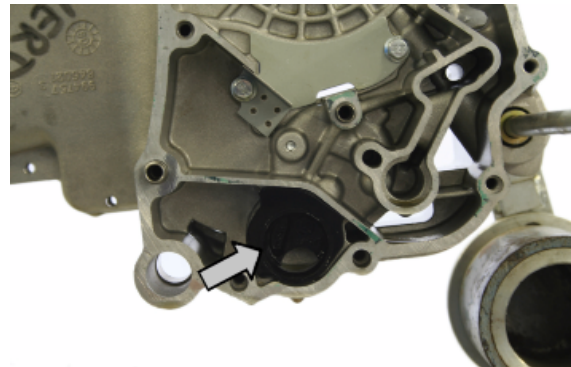

---

## Inspecting the crankshaft components

N.B.

TO MEASURE WEAR LIMITS AND COUPLING CLEARANCES, SEE THE SPECIFICATIONS CHAPTER.

See also

[Crankcase - crankshaft - connecting rod](#)

---

## Inspecting the crankshaft alignment

N.B.

TO MEASURE WEAR LIMITS AND COUPLING CLEARANCES, SEE THE SPECIFICATIONS CHAPTER.

See also

[Crankcase - crankshaft - connecting rod](#)

## Inspecting the crankcase halves

- Before proceeding to check the crankcase halves, thoroughly clean all surfaces and oil ducts.
- On the transmission-side crankcase half, take particular care when handling the oil pump compartment and the oil ducts, the by-pass duct, the main bushings and the cooling jet on the transmission side (see diagram).
- Take particular care, also, that there are no signs of wear in the oil by-pass valve housing (see Chapter Lubrication), as this could prevent a good seal in the piston, which regulates the oil pressure.
- On the flywheel side crankcase half, take particular care cleaning the oil ducts for the main bushings, the oil duct for the jet that lubricates the cylinder head and the oil drainage duct at the flywheel side oil seal.
- Inspect the coupling surfaces on the crankcase halves for scratches or deformation, taking particular care with the cylinder/crankcase surfaces and the crankcase halves surfaces.
- Defects in the crankcase coupling gasket between the crankcase halves or the mating surfaces shown in the diagram, could cause a drop in the oil pressure lubricating the main bushings and connecting rod.
- Check the main bearing seats that limit axial clearance in the crankshaft show no signs of wear. The dimension between these seats is measured by way of the procedure described previously for measuring the crankshaft axial clearance and dimensions.

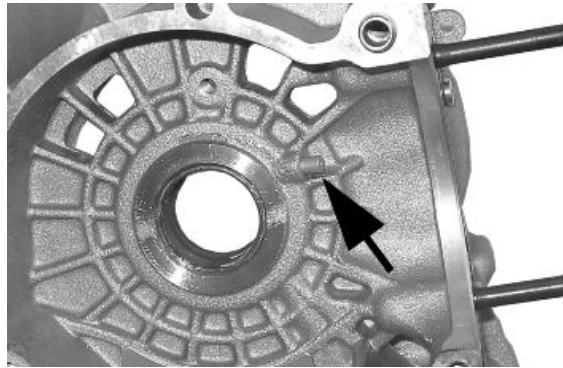

### N.B.

**THE JET IS FED THROUGH THE MAIN BUSHINGS. PROPER OPERATION OF THIS COMPONENT IMPROVES PISTON CROWN COOLING. CLOGGING HAS EFFECTS THAT ARE DIFFICULT TO DETECT (PISTON TEMPERATURE INCREASE). FAILURE OR LEAKS CAN CAUSE A CONSIDERABLE DROP IN THE LUBRICATION PRESSURE FOR MAIN BUSHINGS AND CONNECTING ROD.**

### N.B.

THE HEAD LUBRICATION CHANNEL IS PROVIDED WITH A SHUTTER JET; THIS GIVES A "LOW PRESSURE" HEAD LUBRICATION; THIS CHOICE WAS MADE TO REDUCE THE OIL TEMPERATURE IN THE SUMP. THE JET CLOGGING IMPAIRS THE HEAD LUBRICATION AND THE TIMING MECHANISMS. A JET FAILURE CAUSES A DECREASE OF THE MAIN BUSHING AND CONNECTING ROD LUBRICATION PRESSURE.

## Inspecting the crankshaft plain bearings

- To obtain a good bushing lubrication it is necessary to have both an optimal lubricating pressure (3.2 bar) and a good oil flow rate; the bushings must be correctly positioned so as not to obstruct the oil supply channels.
- The main bushings are comprised of two half-bearings, one with holes and channels for lubrication whereas the other is solid.

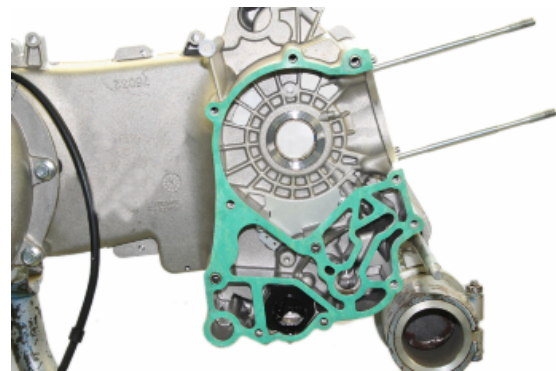

- The solid half-bearing is intended to stand the thrusts caused by combustion, and for this reason it is arranged opposite the cylinder.
- To prevent shutters in the oil feeding channels, the matching surface of the two half-bearings must be perfectly orthogonal to the cylinder axis, as shown in the figure.

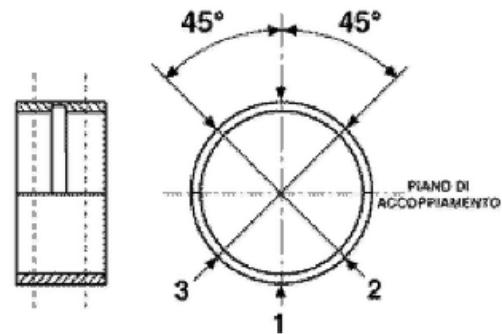

- The oil feeding channel section is also affected by the bushings driving depth compared with the crankshaft axial clearance of the limiting surface.

**N.B.**

**TO MEASURE WEAR LIMITS AND COUPLING CLEARANCES, SEE THE SPECIFICATIONS CHAPTER.**

**See also**

[Crankcase - crankshaft - connecting rod](#)

## Coupling chart

**N.B.**

**TO MEASURE WEAR LIMITS AND COUPLING CLEARANCES, SEE THE SPECIFICATIONS CHAPTER.**

**See also**

[Crankcase - crankshaft - connecting rod](#)

## Refitting the crankcase halves

- Fit the internal bulkhead and lock the two screws to the prescribed torque.
- Fit the oil filter fitting and tighten it to the prescribed torque.
- Position the oil pre-filter element as shown in the picture.

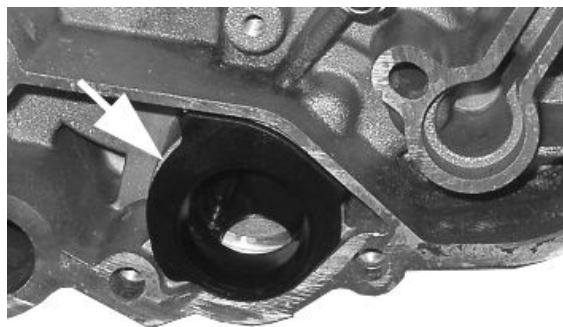
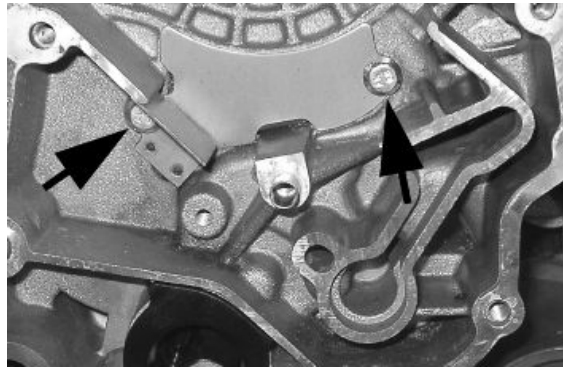

- Place a new gasket on one of the crankcase halves, preferably on the transmission side, together with the alignment dowels.

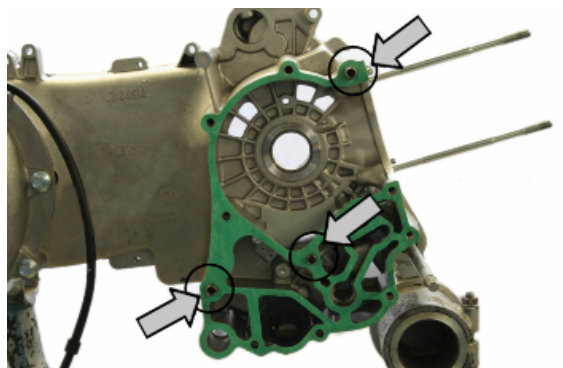

- Lubricate the main bushings with engine oil and insert the crankshaft in the transmission-side crankcase half.
- Reassemble both crankcase halves.
- Fit the ten screws and tighten them to the prescribed torque.
- Assemble a new O-Ring on the pre-filter and lubricate it with engine oil.
- Insert the filter on the engine with the relative cap.
- Tighten to the specified torque.

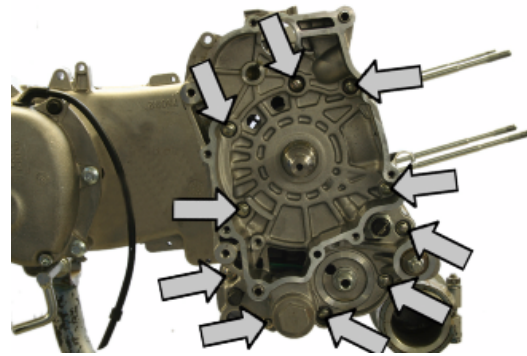

**Locking torques (N\*m)**

**Internal engine crankcase bulkhead (transmission-side half shaft) screws 4 to 6 Engine-crankcase coupling screws 11 to 13 Oil filter on crankcase fitting 27 to 33 Engine oil drainage plug/ mesh filter 24 to 30**

**Studs**

Check that the stud bolts have not worked loose from their seat in the crankcase.

Check the depth of stud bolt driving with a gauge, as indicated in the picture. If it varies significantly from the driving depth indicated, it means that the stud bolt has yielded.

In this case, replace it.



By working on two fitted cylinder head fixing nuts, nut and lock nut, as shown in the picture, remove the stud bolt from its seat.

Clean the threaded seat on the carter thoroughly. Refit a new stud bolt and apply the special product on the threading crankcase side.

Tighten up to the depth of the driving indicated.



**Recommended products**

**Loctite Quick Set Loctite 270 high strength threadlock**

Loctite 270 high strength threadlock

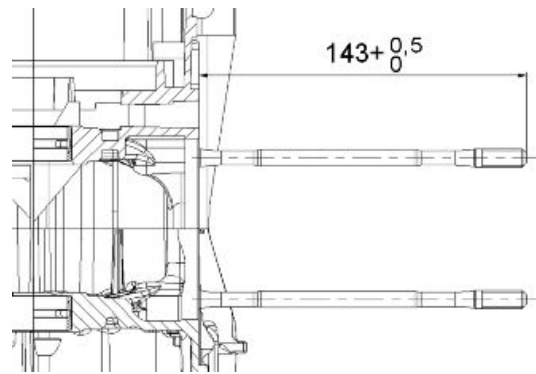

## Lubrication

### Conceptual diagrams

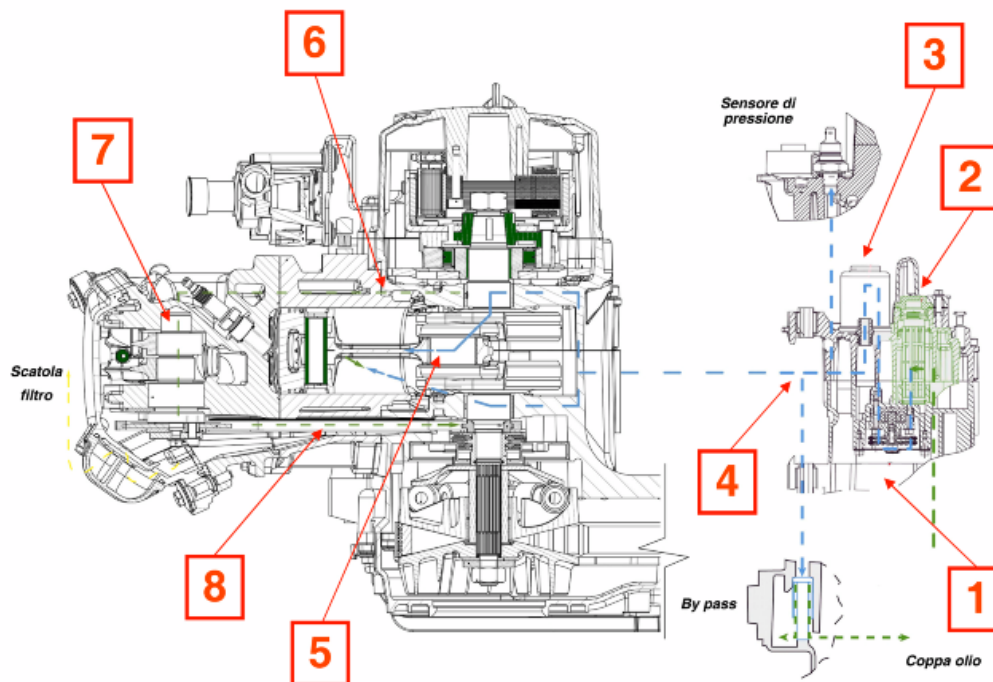

The high pressure circuit is highlighted in blue. The low pressure circuit is highlighted in green. The lobe pump «1» sucks in oil from the sump through the mesh pre-filter «2», pushes it into the cartridge filter «3»; the main bushings and the big end are lubricated (with high pressure) through the suitable passages found in the crankcase halves «4» whereas the piston pin and connecting rod small end are lubricated via jet «5».

Afterwards, the oil, through a nozzle «6» whose function is to reduce the flow rate, reaches the timing system where it lubricates the camshaft and from there, the valves and rockers «7». The oil passes through the timing chain conduit and returns to the sump «8» by gravity.

---

## Oil pressure check

- Remove the electrical minimum oil pressure switch connection and remove the switch.
- Check that the oil pressure reading is between 0.5 and 1.2 atm with the engine idling at 1650 rpm and the oil at the required temperature (wait for at least one electric ventilation).
- Check that the oil pressure is between 3.2 and 4.2 atm with the engine running at 6000 rpm and the oil at the required temperature.
- Remove the appropriate tools once the measurement is complete, refit the oil pressure switch and washer, tightening it to the specified torque and fit the flywheel cover.
- If the oil pressure is not within the specified limits, in the following order, check: the oil filter, the oil by-pass valve, the oil pump and the crankshaft seals.

**N.B.**

THE CHECK MUST BE CARRIED OUT WITH OIL AT THE CORRECT LEVEL AND WITH AN OIL FILTER IN PROPER CONDITION.

**Characteristic****Oil pressure**

Minimum pressure admitted at 6000 rpm: 3.2 atm.

**Locking torques (N\*m)**

Minimum oil pressure sensor 12 to 14

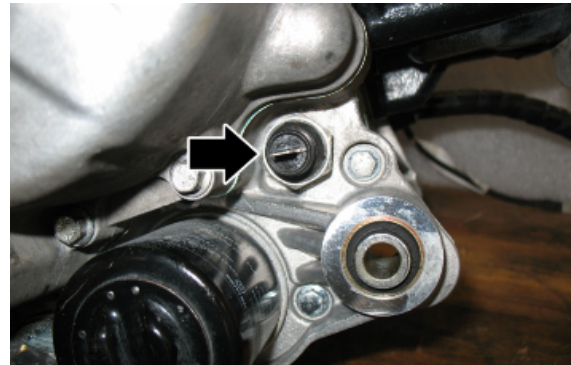

---

## Crankshaft oil seals

---

## Removal

- Remove the transmission cover and the complete drive pulley beforehand

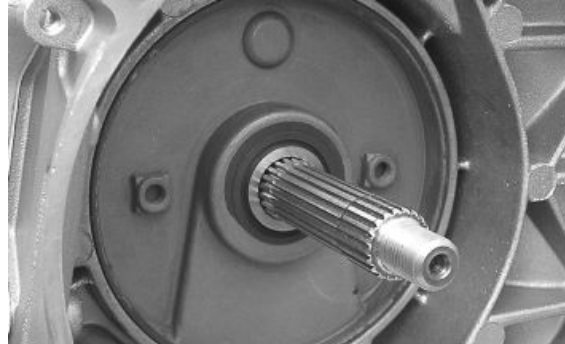

- Install the base of the appropriate tool on the oil seal using the screws provided.

### Specific tooling

**020622Y Transmission-side oil seal punch**

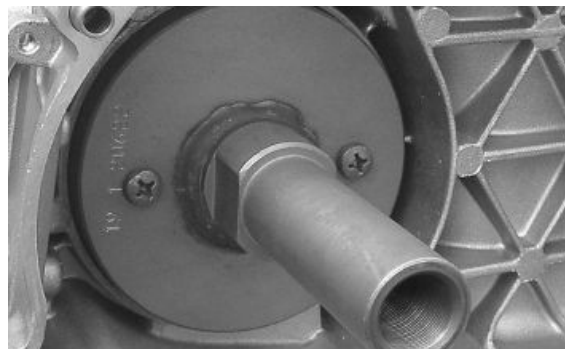

- Screw the threaded bar onto the base of the tool and extract the oil seal.

### Specific tooling

**020622Y Transmission-side oil seal punch**

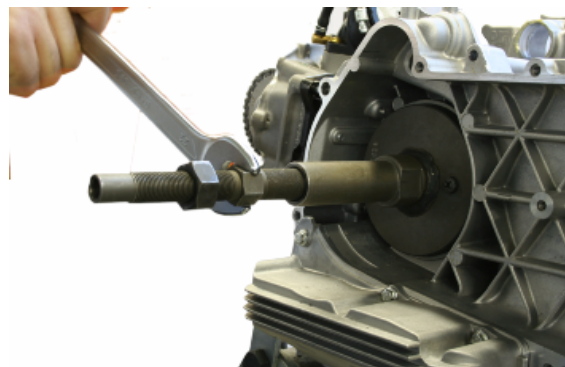

## Refitting

- Always use a new oil seal upon refitting
- Prepare the new oil guard by lubricating the sealing lip.
- Preassemble the oil seal with the appropriate tool by positioning the screws.
- Insert the sheath over the crankshaft.
- Insert the tool with the oil seal on the crankshaft until it comes into contact with the crankcase.
- Insert the adaptor bushing of the tool in the hole on the crankcase.

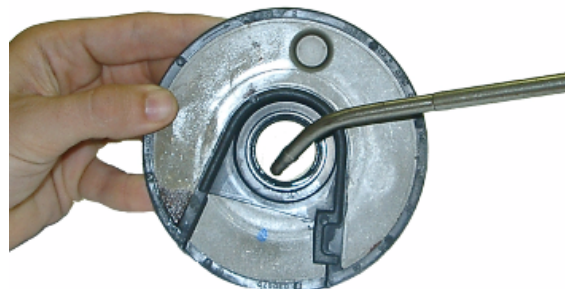



- Orientate the oil seal by inserting the bracket which is part of the appropriate tool.
- Tighten the threaded bar onto the crankshaft as far as it will go.
- Use the nut to move the base of the tool until you can see the end of the oil seal driving stroke
- Remove all the tool components following the procedure but in reverse order

**CAUTION**

**DO NOT LUBRICATE THE KEYING SURFACE ONTO THE ENGINE CRANKCASE.**

**CAUTION**

**ORIENT THE OIL SEAL BY POSITIONING THE CHAIN HOUSING CHANNEL FACING DOWNWARDS. WHEN THE POSITION IS REACHED, DO NOT RETRACT THE OIL SEAL. FAILURE TO COMPLY WITH THIS RULE CAN CAUSE A WRONG POSITIONING OF THE OIL SEAL SHEATH.**

**CAUTION**

**FAILURE TO COMPLY WITH THIS ASSEMBLY PROCEDURE CAN SERIOUSLY DAMAGE THE ENGINE DUE TO THE WRONG TENSIONING OF THE OIL PUMP CONTROL CHAIN.**

**Specific tooling**

**020622Y Transmission-side oil seal punch**

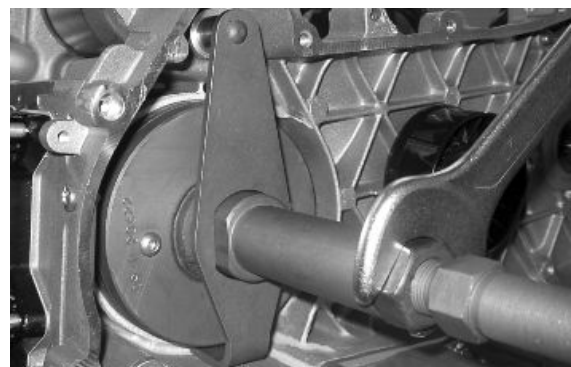
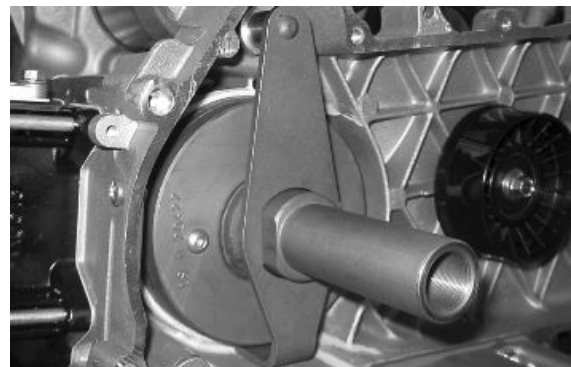
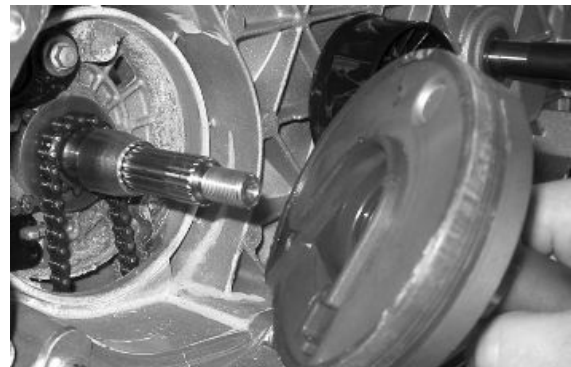
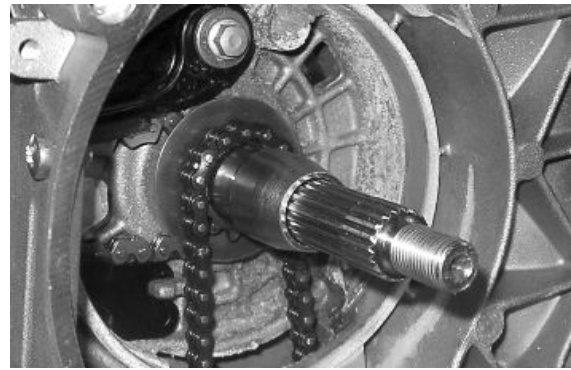

---

**Oil pump**

---

## Removal

- Undo the two clamping screws in the figure and remove the cover over the pump control sprocket.

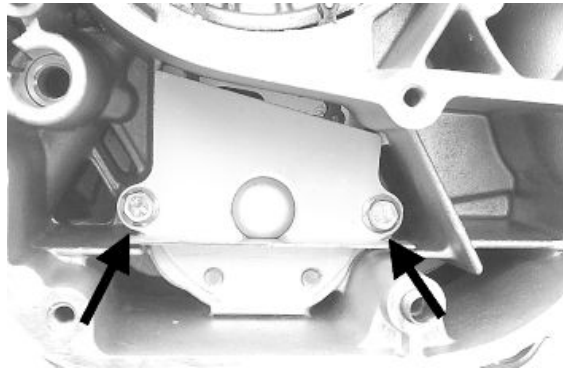

- Block the rotation of the oil pump control pulley with a screwdriver inserted through one of its two holes.
- Remove the central screw with Belleville washer, as shown in the diagram.
- Remove the chain with the crown.
- Remove the control sprocket wheel with relative O-ring.
- Remove the oil pump by undoing the two screws in the figure.
- Remove the oil pump seal.

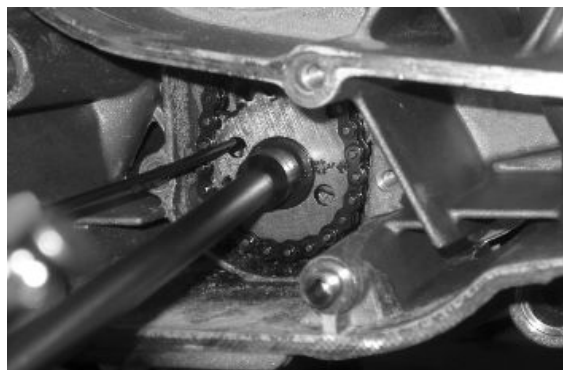

### N.B.

IT IS ADVISABLE TO MARK THE CHAIN IN ORDER TO ENSURE THAT THE INITIAL DIRECTION OF ROTATION IS MAINTAINED.

## Inspection

- Remove the two screws and the oil pump cover.
- Remove the circlip retaining the innermost rotor.
- Remove and wash the rotors thoroughly with petrol and compressed air.
- Reassemble the rotors in the pump body, keeping the two reference marks visible. Replace the retainer ring.

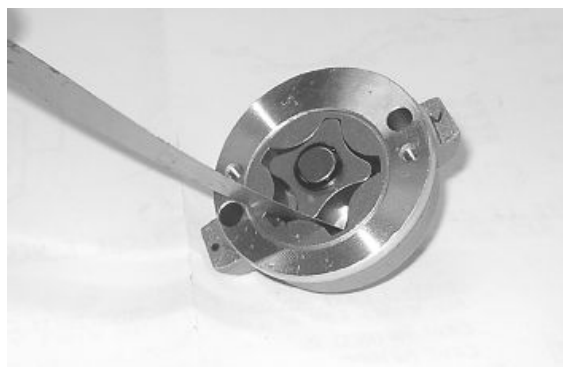

- Check the clearance between the rotors in the position shown in the diagram using a feeler gauge.

Measure the distance between the outer rotor and the pump body (see figure).

- Check the axial clearance of the rotors using a trued bar as shown in the figure.



### Characteristic

#### Axial rotor clearance

Limit values admitted: 0.09 mm

#### Distance between the outer rotor and the pump body

Admissible limit clearance: 0.20 mm

#### Distance between the rotors

Admissible limit clearance: 0.12 mm

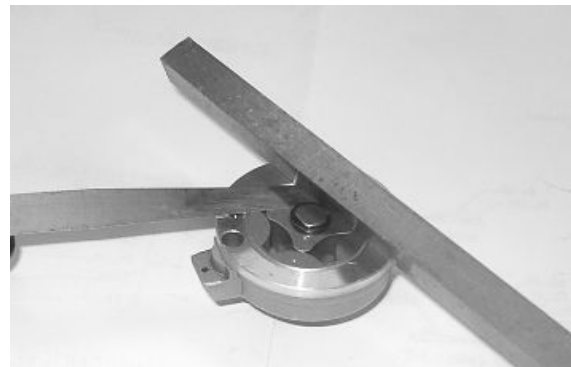

## Refitting

- Check there are no signs of wear on the oil pump shaft or body.
- Check there are no signs of scoring or wear on the oil pump cover.
- If you detect non-conforming measurements or scoring, replace the faulty parts or the unit.
- Fit the pump cover in the position that permits the crankcase clamping screws to be aligned.
- Make sure the gasket is positioned properly and refit the pump on the engine crankcase. The pump can only be fitted in one position. - Tighten the screws to the prescribed torque.

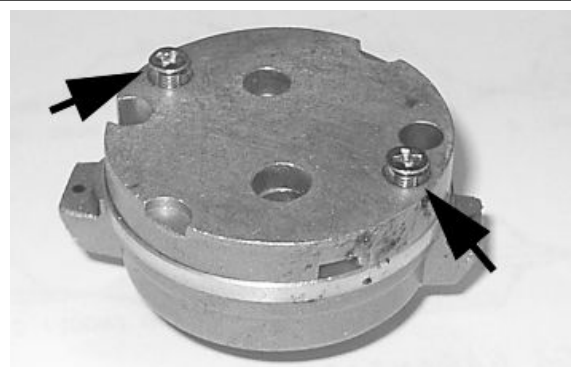

- Fit the sprocket wheel with a new O-ring.
- Fit the chain.
- Fit the central screw and the cup washer. Tighten to the prescribed torque.
- Fit the oil pump cover, by tightening the two screws to the prescribed torque.

**N.B.**

**FIT THE BELLEVILLE WASHER SO THAT ITS OUTER RIM TOUCHES THE PULLEY. MAKE SURE THAT THE PUMP TURNS FREELY.**

**Locking torques (N\*m)**

**Screws fixing oil pump to the crankcase 5 to 6  
Oil pump command sprocket screw 10 to 14  
Oil pump cover screws 0.7 - 0.9**

**Removing the oil sump**

- Drain the oil from the sump.
- Remove the seven screws indicated in the figure and the bracket of the rear brake pipes.

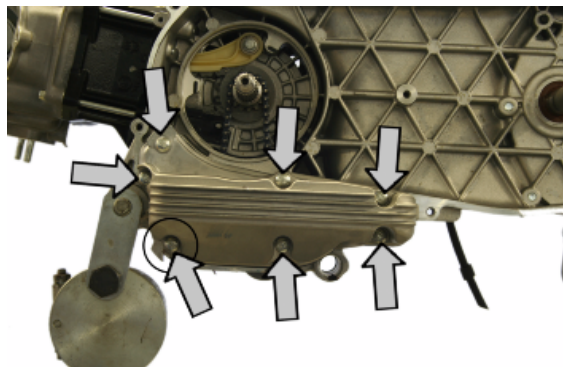

- Check the correct position of the three alignment dowels «1» and remove gasket «2», spring and by-pass piston «3».

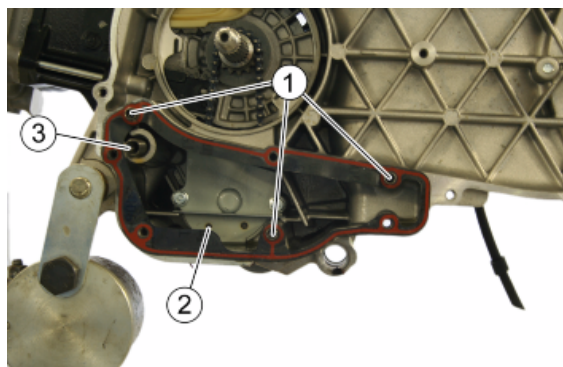

## Inspecting the by-pass valve

- Check the unloaded spring length.
- Check that the small piston is not scored.
- Ensure that it slides freely on the crankcase and that it guarantees a good seal.
- If not, eliminate any impurities or replace defective parts.

### Characteristic

**By-pass check up: Standard length**

54.2 mm

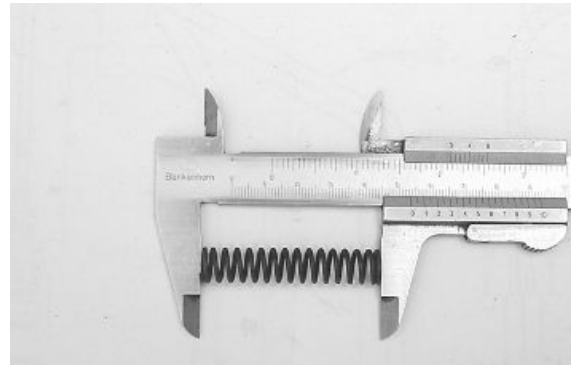

## Refitting the oil sump

- Check the correct position of alignment dowels «1».
- Fit a new gasket «2».
- Fit the by-pass piston and spring «3».

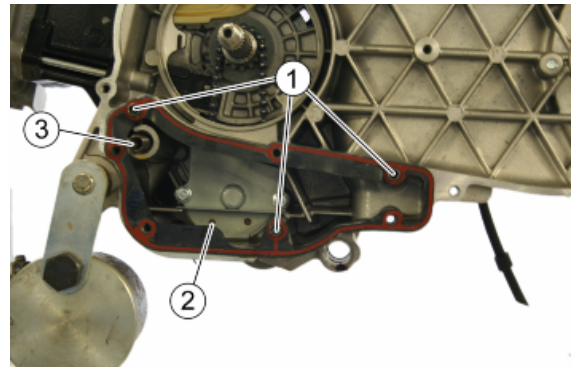

- Assemble the oil sump by tightening the seven fixing screws and be careful with the plate indicated.
- Tighten to the specified torque.

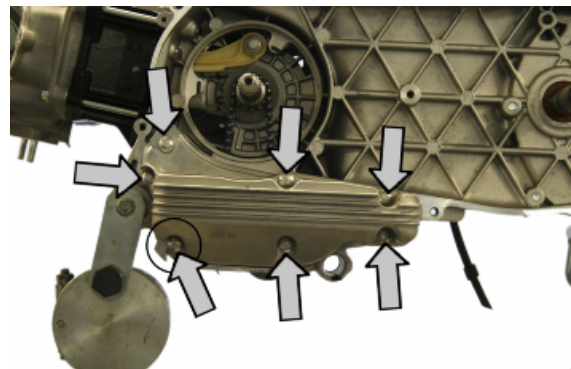

### Locking torques (N\*m)

**Oil sump screws 10 to 14**

## INDEX OF TOPICS

INJECTION

INJEC



**COMPONENT LAYOUT**

	Specification	Desc./Quantity
1	Battery	12V - 10Ah
2	Diagnostics socket connector	
3	Electric fan solenoid	
4	Injection load solenoid	
5	Water temperature sensor	
6	Throttle body and electronic injection control unit (MIU)	
7	Fuel injector	
8	HV coil	
9	Lambda probe	
10	Fuel pump	
11	Speed sensor	

**MIU injection system**

This vehicle is fitted with an integrated injection and ignition system.

Injection is indirect in the manifold through an electro-injector.

The injection and ignition are timed on the four-stroke cycle by means of a tone wheel keyed on to the crankshaft (24-2 teeth) and pick-up sensor.

Combustion and ignition are managed on the basis of engine revs and throttle valve opening. Further corrections are made according to the following parameters:

- Coolant temperature.
- Intake air temperature
- Lambda probe

The system implements an idle feeding correction with cold engine through a Stepper motor on a by-pass circuit of the throttle valve. The control unit manages the Stepper motor and the injector opening time, thereby ensuring the idle steadiness and the proper combustion.

In all conditions of use, mixture preparation is managed by modifying the injector opening time.

The fuel system pressure is kept constant based on the ambient pressure.

The **fuel system circuit** consists of:

- Fuel pump
- Fuel filter
- Injector
- Pressure regulator

The pump, the filter and the regulator are placed inside the fuel tank on a single support.

The injector is connected by two pipes provided with quick couplings. This allows obtaining a continuous circulation, thereby avoiding the risk of fuel boiling. The pressure regulator is situated at the end of the circuit.

The fuel pump is controlled by the MIU control unit; this ensures the scooter safety

The **ignition circuit** consists of:

- HV coil
- HV cable
- Shielded cap
- MIU control unit
- Spark plug

The MIU control unit manages ignition with the best advance ensuring four-stroke timing (ignition only in the compression phase) at the same time.

The MIU injection-ignition system controls engine functions by means of a pre-set program.

Should any input signals fail, an acceptable working order of the engine is ensured to allow the user to reach a service station.

Of course, this cannot happen when the rpm-timing signal is missing, or when the failure involves the control circuits:

- Fuel pump
- HV coil
- Injector



The control unit is provided with a self-diagnosis system connected to an indicator light in the instrument panel.

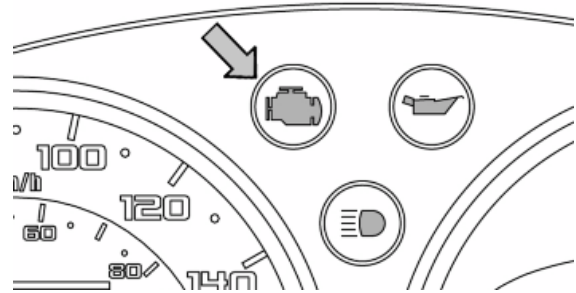

Failures are detected and restored by the diagnostic tester.

In any case, when the fault is no longer present, the data storage is automatically cleared after 16 cycles of use (cold start, running at regular engine temperature, stop).

The diagnostic tester is also required to adjust the idle mixture.



### Specific tooling

#### 020680Y Diagnosis Tool

The MIU injection-ignition system carries out checks on the rpm indicator and the electric fan for radiator cooling.

The MIU control unit has a decoder for the anti-theft immobilizer system.

The MIU control unit is connected to a diagnostic LED on the instrument panel, that also carries out the deterrent flashing functions.

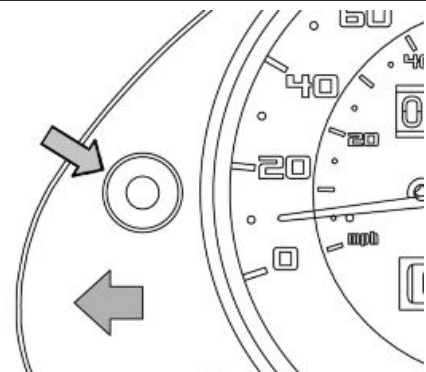

The MIU control unit power supply is furthermore controlled by the emergency switch; that is to provide further safety for the vehicle.

## Precautions

### Troubleshooting hints

1 A MIU failure is more likely to be due to the connections than to the components.

Before troubleshooting the MIU system, carry out the following checks:

#### A: Electrical power supply

- a. Battery voltage
- b. Blown fuse
- c. Remote controls

## d. Connectors

**B:** Chassis ground**C:** Fuel system

a. Broken fuel pump

b. Dirty fuel filter

**D:** Ignition system

a. Faulty spark plug

b. Broken coil

c. Broken shielded cap

**E:** Intake circuit

a. Dirty air filter

b. Dirty by-pass circuit

c. Faulty Stepper motor

**F:** Other

a. Incorrect distribution timing

b. Wrong idle mixture

c. Incorrect reset of the throttle valve position sensor

2 MIU system faults may be caused by loose connectors. Make sure that all connections have been correctly made.

Check the connections as follows:

**A** check that the terminals are not bent.**B** check that the connectors have been properly connected.**C** check whether the malfunction can be fixed by shaking the connector slightly.

3 Check the entire system before replacing the MIU. If the fault is fixed by replacing the MIU control unit, install the original control unit again and check if the fault occurs again.

4 Use a multimeter with an internal resistance of more than 10K Ohm /V when troubleshooting. Instruments that are not suitable might damage the MIU central control unit. Use instruments with definitions over 0.1V and 0.5 W, the precision must be greater than 2%.

1. Before fixing any part of the injection system, check to see if there are any registered faults. Do not disconnect the battery before checking for faults.

2. The fuel supply system is pressurised at 250 kPa (2.5 BAR). Before disconnecting the fast-release fitting of the fuel supply pipe, check that there are no naked flames. Do not smoke. Act with caution to avoid spraying fuel to your eyes.

3. When fixing electric components, operate with the battery connected only when actually required.

4. When functional checks are performed, check that the battery voltage is over 12V.

5. Before any attempt to start the vehicle, check to make sure there is at least two litres of fuel in the tank. Failure to respect this norm will damage the fuel pump.

6. If the vehicle is expected to remain unused for a long time, refill the tank up to a little over half the level. This will ensure the pump will be covered by fuel.
7. When washing the vehicle, be careful with the electric components and cable harnesses.
8. When an ignition problem is detected, start the checks from the battery and the injection system connections.
9. Before disconnecting the MIU ECU connector, perform the following steps in the order shown:
  - Set the switch to «OFF»
  - Disconnect the batteryFailure to respect this norm may damage the control unit.
10. Do not invert the poles when fitting the battery.
11. To avoid causing any damage, disconnect and reconnect the MIU system connectors only if required. Before reconnecting, check that the connectors are dry.
12. When carrying out electric inspections, do not force the tester probes into the connectors. Do not take measurements not specifically foreseen by the manual.
13. At the end of every check performed with the diagnostic tester, remember to protect the system connector with its cap. Failure to observe this precaution may damage the MIU control unit.
14. Before reconnecting the quick couplers of the power supply system, check that the terminals are perfectly clean.

---

## Terminals setup

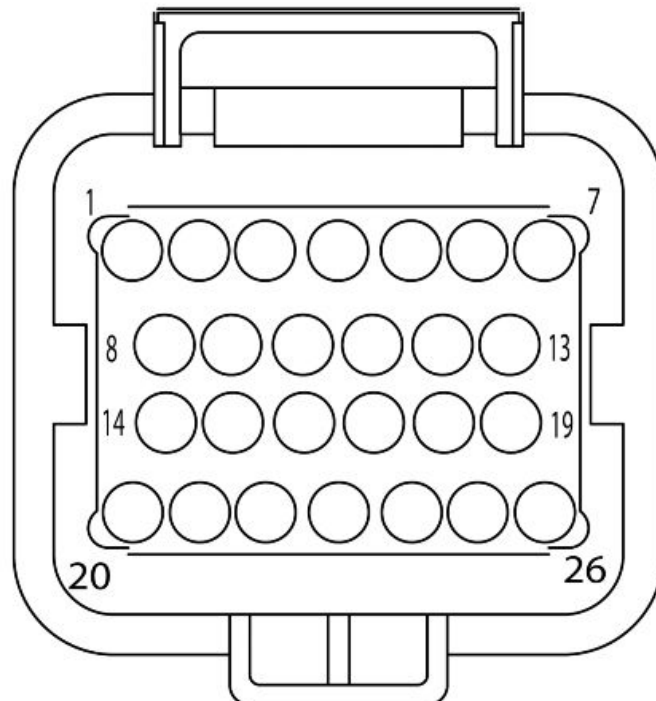

**TERMINAL LAYOUT**

	Specification	Desc./Quantity
1	Injection telltale light	
2	-	
3	-	
4	Lambda probe negative	
5	Live supply	
6	Battery-powered	
7	Immobilizer aerial	
8	Electric fan solenoid	
9	Water temperature sensor	
10	-	
11	Lambda probe positive	
12	engine stop switch	
13	Engine speed sensor (+)	
14	Fuel injector	
15	Engine speed sensor (-)	
16	Diagnostics socket output	
17	Immobilizer LED	
18	Side stand	
19	-	
20	Injection load solenoid	
21	-	
22	HV coil	
23	-	
24	Start up enabling	
25	-	
26	Ground lead	Connected with: water temperature sensor, stand witch and engine stop switch.

**EMS circuit diagram**

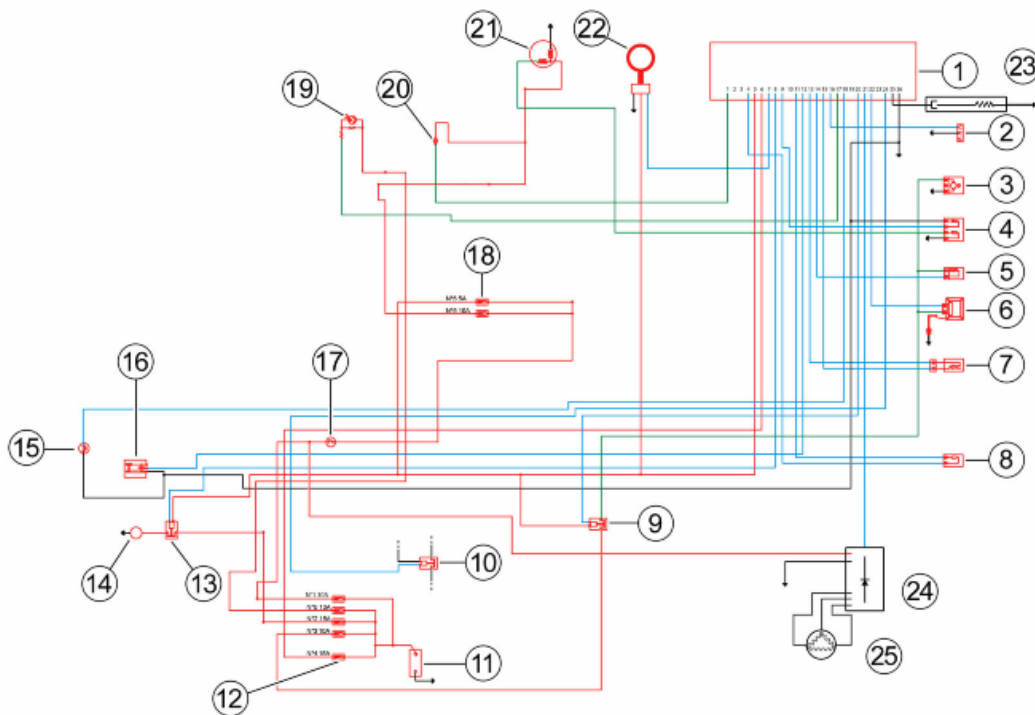

**SYSTEM DIAGRAM**

	<b>Specification</b>	<b>Desc./Quantity</b>
1	Injection ECU	
2	Diagnostics socket connector	
3	Fuel pump	
4	Water temperature sensor	
5	Fuel injector	
6	HV coil	
7	Speed sensor	
8	Lambda probe	
9	Injection load solenoid	
10	Start-up solenoid	
11	Battery	12V - 12 Ah
12	Main fuses	
13	Electric fan solenoid	
14	Electric fan	
15	Stand switch	
16	engine stop switch	
17	Ignition key contacts	
18	Auxiliary fuses	
19	Immobilizer LED	
20	"WARNING" light	
21	Water temperature gauge	
22	Immobilizer aerial	
23	Fall sensor	
24	Voltage regulator	
25	Magneto flywheel	

**Troubleshooting procedure**

**Engine does not start**

**ENGINE DOES NOT START IF ONLY PULLED**

<b>Possible Cause</b>	<b>Operation</b>
Immobiliser enabling signal	System not encoded System not efficient, repair according to the indications of the self-diagnosis
Presence of faults detected by the self diagnosis	Pump relay HV coil Injector Revolution timing sensor
Fuel system	Fuel in the tank Fuel pump activation Fuel pressure (low) Injector capacity (low)
Power to the spark plug	Shielded spark plug cap HV coil (secondary insulation)
Parameter reliability	Coolant temperature Distribution timing - injection ignition Intake air temperature
End of compression pressure	End of compression pressure

**Starting difficulties**

**ENGINE START-UP PROBLEMS**

<b>Possible Cause</b>	<b>Operation</b>
Presence of faults detected by the self diagnosis	Pump relay HV coil Injector Revolution timing sensor

Possible Cause	Operation
Start-up speed	Air temperature
	Coolant temperature
	Starter motor and solenoid
End of compression pressure	Battery
	Ground connections
	End of compression pressure
Power to the spark plug	Spark plug
	Shielded cap
	HV coil
Fuel system	Speed-timing sensor
	Ignition advance
	Fuel pressure (low)
Correctness of the parameters	Injector capacity (low)
	Injector sealing (poor)
	Coolant temperature
	Stepper throttle valve position intake air temperature (steps and actual opening)
	Cleaning of the auxiliary air pipe and throttle valve; air filter efficiency

### Engine stops at idle

#### **ENGINE DOES NOT IDLE/ IDLING IS UNSTABLE/ IDLING TOO LOW**

Possible Cause	Operation
Presence of faults detected by the self diagnosis	Pump relay
	HV coil
	Injector
Ignition efficiency	Revolution timing sensor
	Air temperature
	Coolant temperature
Correctness of the parameters	Spark plug
	Ignition timing
	Throttle valve position sensor
Intake system cleaning	Stepper
	Coolant temperature sensor
	Intake air temperature sensor
Intake system sealing (infiltrations)	Air filter
	Diffuser and throttle valve
	Additional air pipe and Stepper
Fuel system (low pressure)	Intake manifold - head
	Throttle body - manifold
	Intake sleeve
	Filter box
	Fuel pump
	Pressure regulator
	Fuel filter
	Injector capacity

### Engine does not rev down

#### **ENGINE DOES NOT RETURN TO IDLING SPEED/IDLING SPEED TOO HIGH**

Possible Cause	Operation
Presence of faults detected by the self diagnosis	Pump relay
	HV coil
	Injector
Ignition efficiency	Revolution timing sensor
	Air temperature
	Coolant temperature
Correctness of the parameters	Ignition timing
	Throttle valve position sensor
	Stepper
	Coolant temperature sensor
	Intake air temperature sensor

Possible Cause	Operation
Intake system sealing (infiltrations)	Intake manifold - head Throttle body - manifold Intake sleeve Filter box
Fuel system (low pressure)	Fuel pump Pressure regulator Fuel filter Injector capacity

### Exhaust backfires in deceleration

#### **EXHAUST BACKFIRES WHEN DECELERATING**

Possible Cause	Operation
Presence of faults detected by the self diagnosis	Pump relay HV coil Injector Revolution timing sensor Air temperature Coolant temperature Lambda probe
Correctness of the parameters	Throttle valve position sensor Stepper Coolant temperature sensor Intake air temperature sensor
Intake system sealing (infiltrations)	Intake manifold - head Throttle body - manifold Intake sleeve Filter box
Fuel system (low pressure)	Fuel pump Pressure regulator Fuel filter Injector capacity
Exhaust system sealing (infiltrations)	Manifold - head Manifold - silencer silencer welding

### Engine revs irregularly

#### **ENGINE IRREGULAR PERFORMANCE WITH VALVE SLIGHTLY OPEN**

Possible Cause	Operation
Intake system cleaning	Air filter Diffuser and throttle valve Additional air pipe and Stepper
Intake system sealing	Intake sleeve Filter box
Ignition system	Spark plug wear check
Parameter reliability	Throttle valve position signal Coolant temperature indicator Intake air temperature indicator Ignition advance
TPS reset successful	TPS reset successful
Presence of faults detected by the self diagnosis	Pump relay HV coil Injector Revolution timing sensor Air temperature Coolant temperature Lambda probe

## Poor performance at full throttle

### POOR ENGINE PERFORMANCE AT FULL POWER/ ENGINE IRREGULAR PERFORMANCE ON PICKUP

Possible Cause	Operation
Presence of faults detected by the self diagnosis	Pump relay HV coil Injector Revolution timing sensor Air temperature Coolant temperature Lambda probe
Spark plug power supply	Spark plug Shielded cap HV cable HV coil
Intake system	Air filter Filter box (sealing) Intake sleeve (sealing)
Parameter reliability	Throttle valve position signal Coolant temperature indicator Intake air temperature indicator Ignition advance
Fuel system	Fuel level in the tank Fuel pressure Fuel filter Injector capacity

## Engine knocking

### PRESENCE OF KNOCKING (COMBUSTION SHOCKS)

Possible Cause	Operation
Presence of faults detected by the self diagnosis	Pump relay HV coil Injector Revolution timing sensor Air temperature Coolant temperature Lambda probe
Ignition efficiency	Spark plug
Parameter reliability	Throttle valve position signal Coolant temperature indicator Intake air temperature indicator Ignition advance
Intake system sealing	Intake sleeve Filter box
TPS reset successful	TPS reset successful
Fuel system	Fuel pressure Fuel filter Injector capacity Fuel quality
Selection of the cylinder base gasket thickness	Selection of the cylinder base gasket thickness

## Fuel supply system

The fuel supply circuit includes the electric pump, the filter, the pressure regulator, the electro-injector and the fuel delivery pipes.

The electrical pump is located in the tank from which the fuel is pumped and sent to the injector through the filter.

The pressure is controlled by the pressure regulator situated in the pump assembly in the tank.



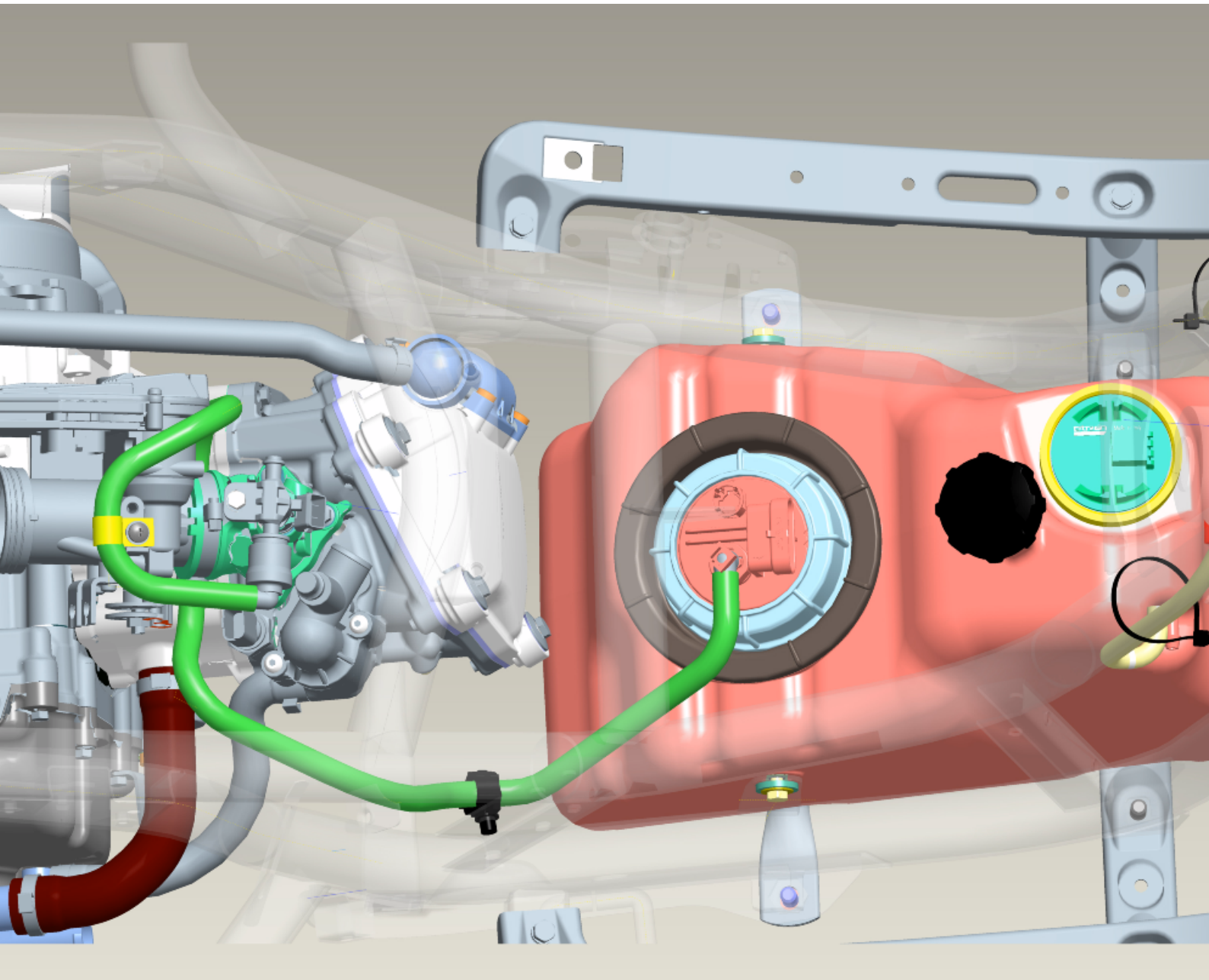

### Removing the butterfly valve

Remove the fuel piping clamping screw indicated in the figure.



Remove the fast-release fittings from the injector support.

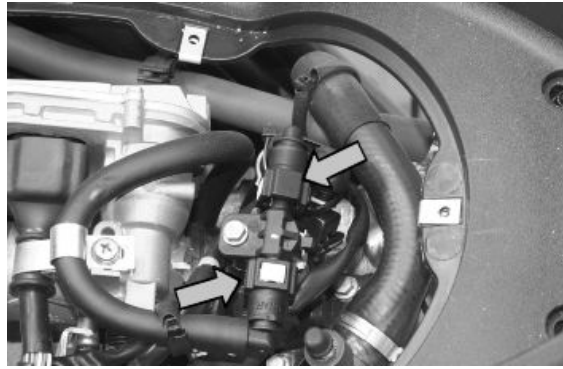

Remove the injector connector.



Remove the three screws fixing the manifold to the cylinder head and the clip fixing the throttle body to the manifold.

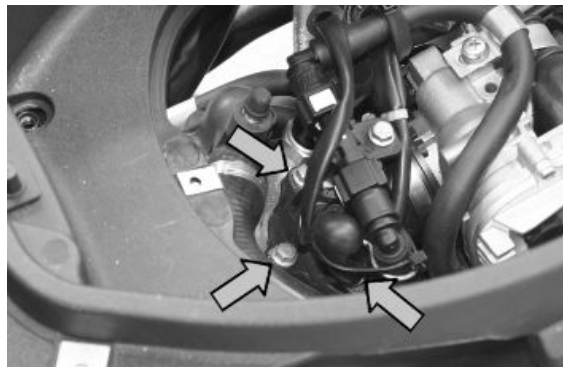

Remove the MIU ECU connector.

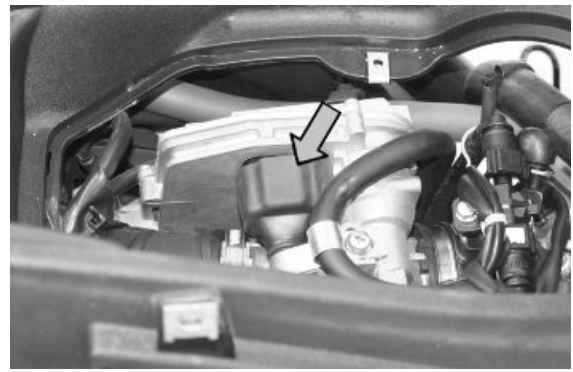

Remove the clip fixing the throttle body to the air cleaner bellows.

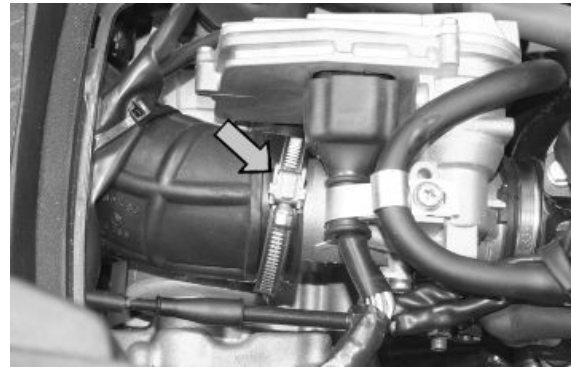

Remove the gas command fitting as indicated in the picture



## Refitting the butterfly valve

To refit, perform the operations in the reverse order from the removal operations being careful to position the clip fixing the throttle body to the air filter bellows at 45° as shown in the photograph.

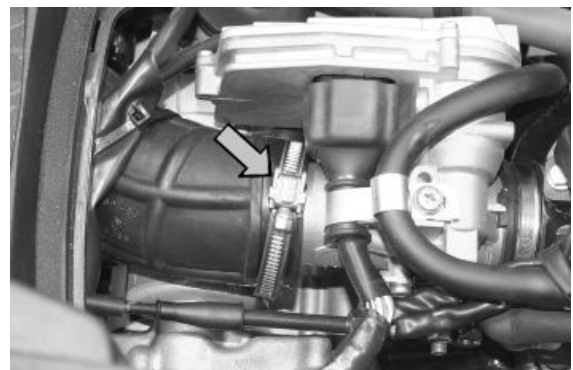

**Pump supply circuit**

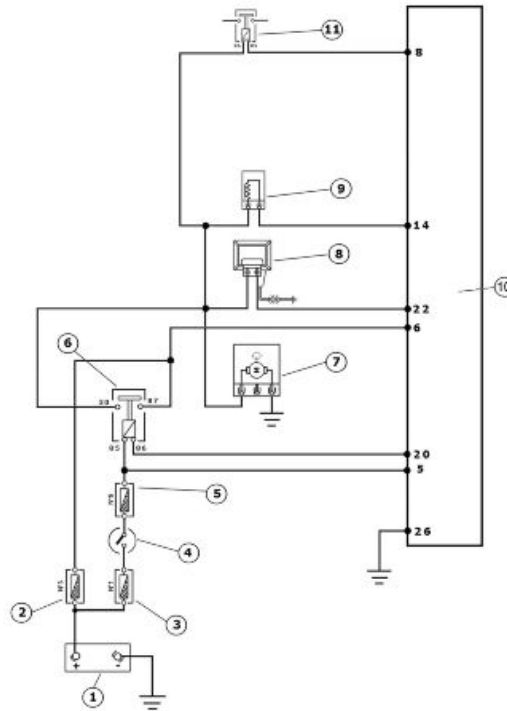

**INJECTION LOADS**

	Specification	Desc./Quantity
1	Battery	12V - 12 Ah
2	Fuse No. 3	10 A
3	Fuse No. 1	30 A
4	Ignition key contacts	
5	Fuse No. 6	5A
6	Injection load solenoid	
7	Fuel pump	
8	HV coil	
9	Fuel injector	
10	Injection ECU	
11	Electric fan solenoid	

When switched to «ON», the fuel pump starts to rotate for 2 seconds and then stops. When the engine starts, in the presence of rpm timing signal the pump is continuously supplied.

**ELECTRICAL DATA**

- Pump winding resistance ~ 1.5 Ohm
- Input current during normal functioning 1.4 to 1.8 A
- Input current to the closed hydraulic circuit ~ 2 A (to be checked with specific tool for fuel pressure control, choking the circuit on the return pipe)

Check function of fuses No. 3 and 6 for the ECU and injection load solenoid.

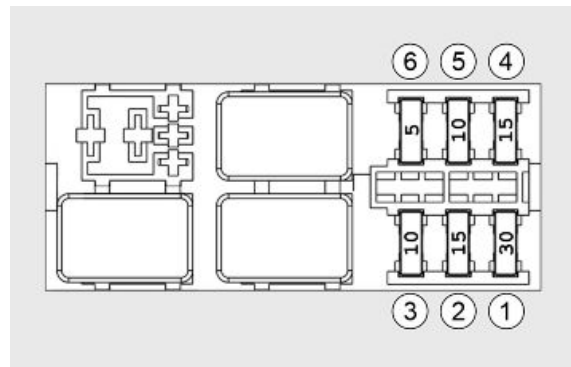
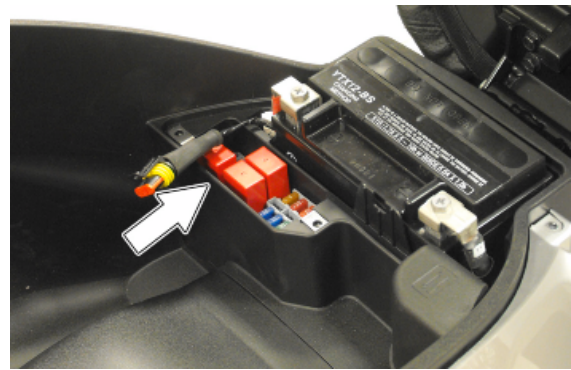

Check the efficiency of the injection load solenoid.  
 Check the resistance of the energising coil between pins 86 and 85: 40 to 80 Ohm  
 Apply a voltage of 12V to pins 86 and 85; make sure that there is continuity between pins 30 and 87 of the solenoid.

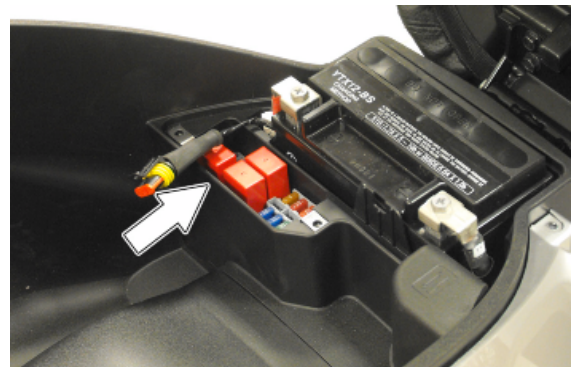

**WARNING**

TO INDICATE THE SOLENOID OF THE DESIRED FUNCTION, REFER TO THE PIN-CABLE COLOUR RELATIONSHIP WITH THE ATTACHED ELECTRIC SYSTEM DIAGRAM.





Check the power supply line of the injection load solenoid energising coil: after switching to «ON», make sure there is battery voltage, for 2 seconds, between the Red-White cable and the Black-Purple cable of the solenoid base. If there is not, check the continuity of the Red-White cable between the fuse box and the solenoid base and of the Black-Purple cable between the pin 20 of the control unit and the solenoid base.

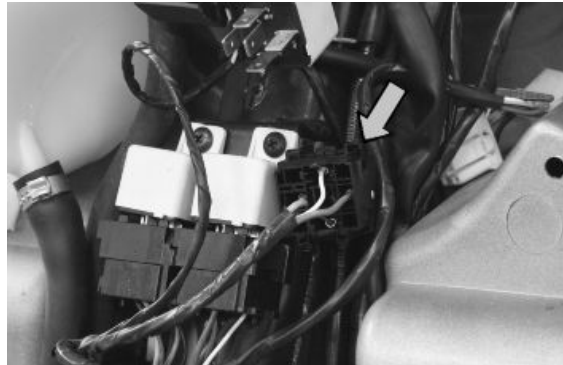

**N.B.**

**CONTINUITY TESTS MUST BE CARRIED OUT WITH THE COMPONENTS DISCONNECTED. (SOLENOIDS, CONTROL UNIT, FUSES ETC.).**

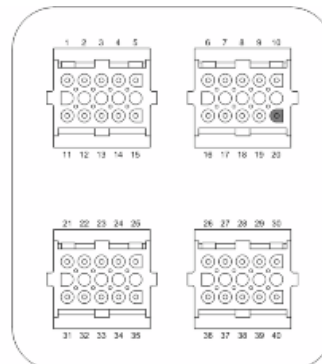

Check for continuous voltage between the grey/black cable of the solenoid base and ground. If no voltage is measured, check continuity of the Grey/Black cable between the fuse box (No. 3, 5A) and the solenoid base.

**N.B.**

**CONTINUITY TESTS MUST BE CARRIED OUT WITH THE COMPONENTS DISCONNECTED. (SOLENOIDS, CONTROL UNIT, FUSES ETC.).**

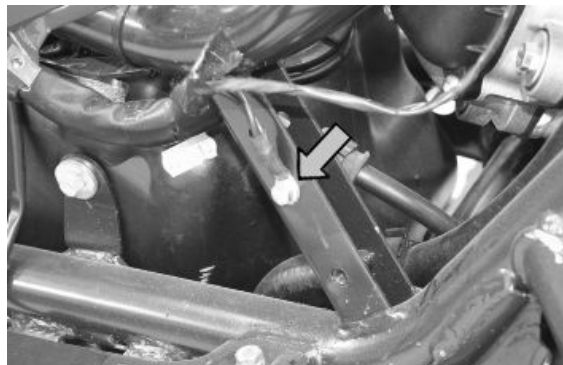

After switching to «ON», check that there is battery voltage, for about 2 seconds, between the Black-Green cable of the pump connector and the ground lead with the pump connector disconnected. Otherwise, check the continuity of the Black-Green cable between the pump connector and the solenoid base.

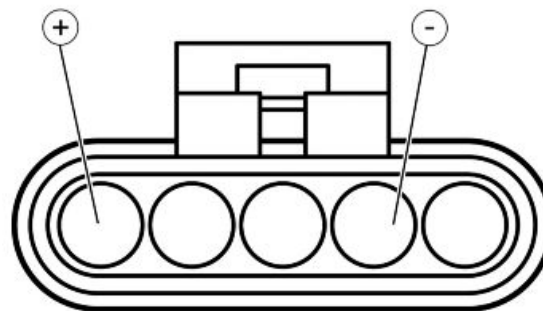

Check the efficiency of the ground line of the fuel pump by measuring the continuity between the pump connector black cable, system side, and the ground.



If, when switching to «ON», the pump continues to turn after 2 seconds of activation, check, with the control unit disconnected and the injection load solenoid disconnected, that the Black-Purple cable (pin 20 on the interface wiring) is insulated from the ground.

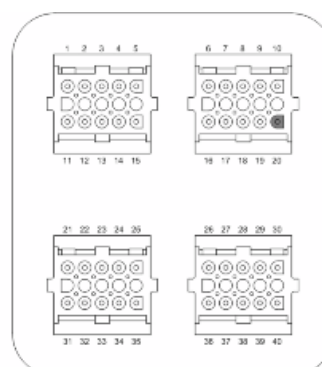

**Specific tooling**

**020331Y Digital multimeter**

**Circuit leak test**

Install the specific tool for checking the fuel pressure, with the pipe fitted with the gauge.

Check during regular operation by placing the appropriate tool between the pump and the injector. With the battery voltage > 12 V check that the fuel pressure is 2.5 BAR and that the input current is 1.4 to 1.8 A



With the battery voltage > 12 V, check the pump flow rate by disconnecting from the injector the pipe equipped with the pressure gauge of the appropriate tool. Get a graded burette with a flow rate of approximately 1 L. Rotate the pump using the active diagnoses of the palm top computer. Using a pair

of long flat needle-nose pliers, choke the fuel pipe making the pressure stabilise at approx. 2.5 BAR. Check that within 15 seconds the pump has a flow rate of approx. 110 cm<sup>3</sup>.

### Specific tooling

020480Y Petrol pressure check kit

## Fuel filter check

Disconnect the terminals from the electric pump

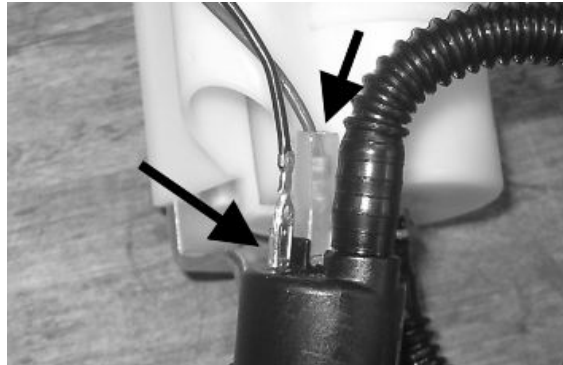

Remove the screw shown in the picture

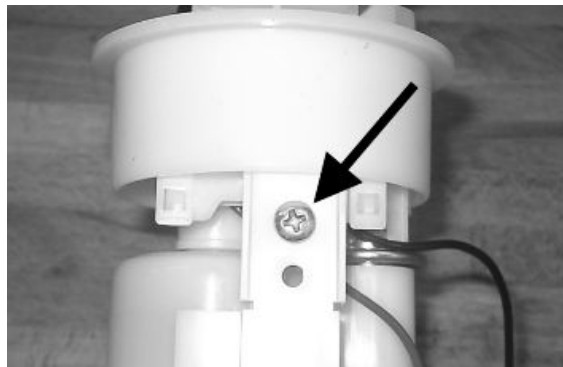

Remove the clip fixing the piping to the filter shown in the picture





Separate the lower part of the pump mounting as shown in the picture.

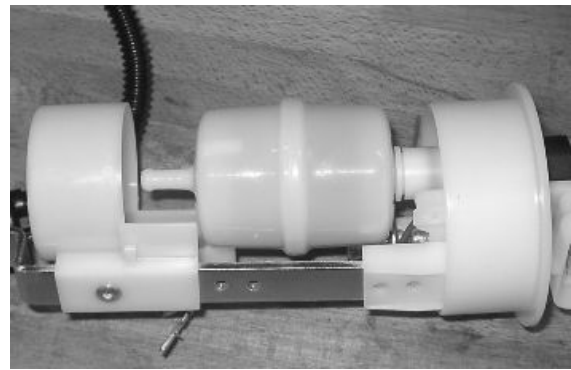

Remove the filter from the pump mounting



### Inspecting the injector circuit

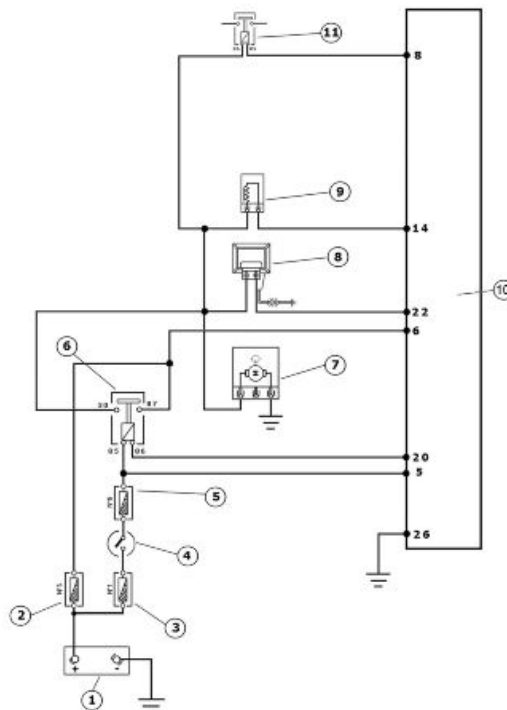

#### INJECTION LOADS

	Specification	Desc./Quantity
1	Battery	12V - 12 Ah
2	Fuse No. 3	10 A
3	Fuse No. 1	30 A

	Specification	Desc./Quantity
4	Ignition key contacts	
5	Fuse No. 6	5A
6	Injection load solenoid	
7	Fuel pump	
8	HV coil	
9	Fuel injector	
10	Injection ECU	
11	Electric fan solenoid	

Check the resistance at the injector ends:  $14.5 \pm 5\%$  Ohm

Check function of fuses No. 3 and 6 for the ECU and injection load solenoid.

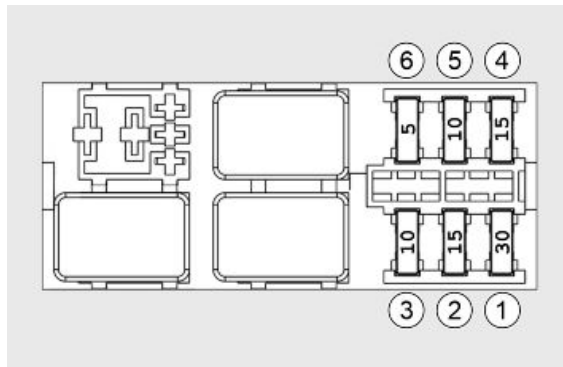
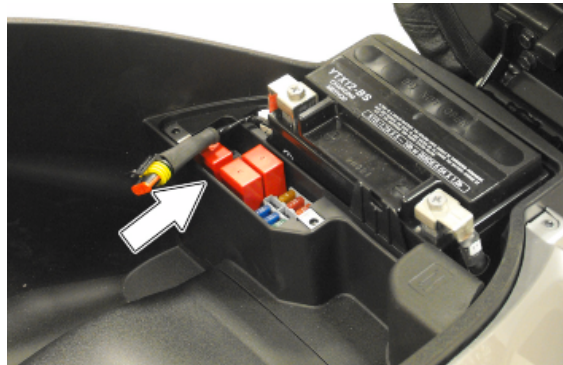

Check the efficiency of the injection load solenoid.  
 Check the resistance of the energising coil between pins 86 and 85: 40 to 80 Ohm  
 Apply a voltage of 12V to pins 86 and 85; make sure that there is continuity between pins 30 and 87 of the solenoid.

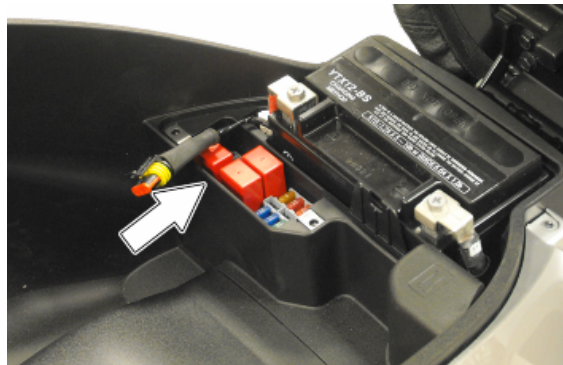

**WARNING**

TO INDICATE THE SOLENOID OF THE DESIRED FUNCTION, REFER TO THE PIN-CABLE COLOUR RELATIONSHIP WITH THE ATTACHED ELECTRIC SYSTEM DIAGRAM.

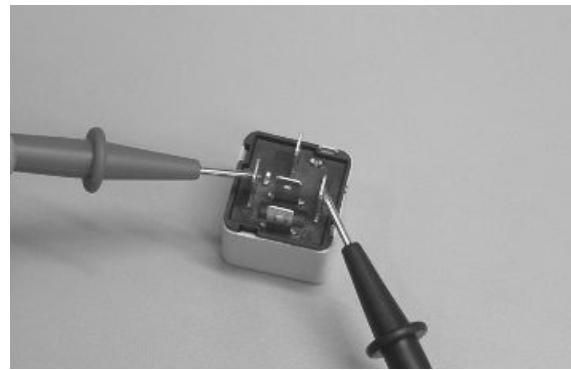

Check the power supply line of the injection load solenoid energising coil: after switching to «ON», make sure there is battery voltage, for 2 seconds, between the Red-White cable and the Black-Purple cable of the solenoid base. If there is not, check the continuity of the Red-White cable between the fuse box and the solenoid base and of the Black-Purple cable between the pin 20 of the control unit and the solenoid base.

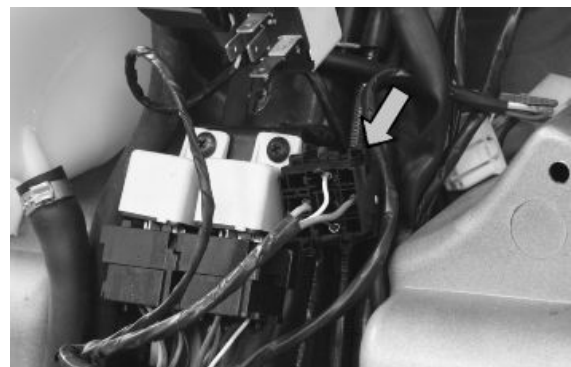

**N.B.**

CONTINUITY TESTS MUST BE CARRIED OUT WITH THE COMPONENTS DISCONNECTED. (SOLENOIDS, CONTROL UNIT, FUSES ETC.).

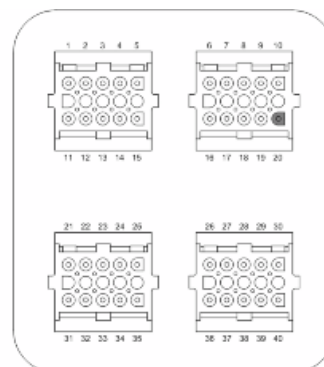

Check for continuous voltage between the grey/black cable of the solenoid base and ground. If no voltage is measured, check continuity of the Grey/Black cable between the fuse box (No. 3, 5A) and the solenoid base.

**N.B.**

**CONTINUITY TESTS MUST BE CARRIED OUT WITH THE COMPONENTS DISCONNECTED. (SOLENOIDS, CONTROL UNIT, FUSES ETC.).**

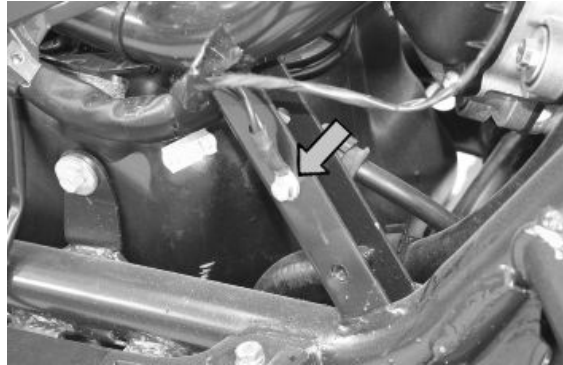

With the control unit and the injector disconnected, check the continuity of the Red-Yellow cable between pin 14 of the interface wiring and the injector connector

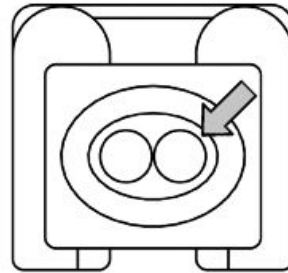

Switch to «ON» and check if there is voltage, with injector disconnected and control unit connected, between the Black-Green cable of the injector connector and the ground lead

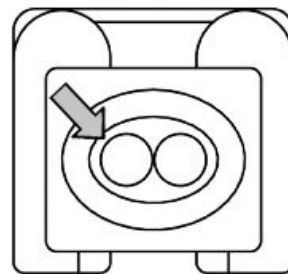

With injector disconnected and the injector load solenoid disconnected, check the continuity of the Black-Green cable between the injector connector and solenoid base.

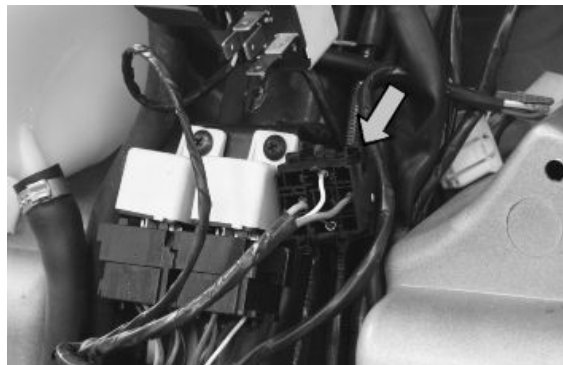

## Inspecting the injector hydraulics

To carry out the injector check, remove the intake manifold by removing the three clamping screws at the head and the clip connecting the control unit to the manifold.

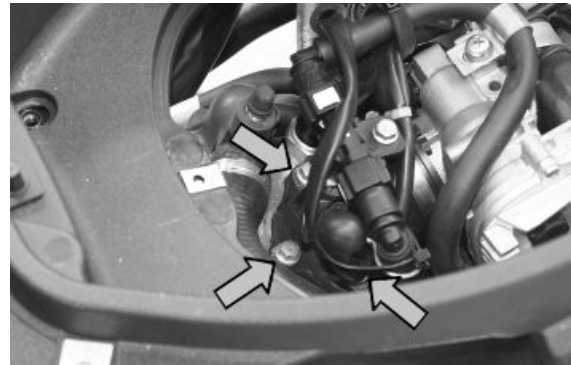

Install the appropriate tool for checking fuel pressure and position the manifold over a container graduated by at least 100 cm<sup>3</sup>. Connect the injector with the cable making up part of the supply for the injection tester. Connect the clamps of the cable to an auxiliary battery. Activate the fuel pump with the active diagnosis. Check that, within fifteen seconds, approximately 40 cm<sup>3</sup> of fuel is dispensed with an adjustment pressure of approximately 2.5 BAR.



### Specific tooling

**020480Y Petrol pressure check kit**

Proceed with the injector seal test.

Dry the injector outlet with a blast of compressed air. Activate the fuel pump. Wait for one minute, making sure there are no leaks coming from the injector. Slight oozing is normal.

Value limit = 1 drop per minute



### Components location



### COMPONENT LAYOUT

	Specification	Desc./Quantity
1	Battery	12V - 10Ah
2	Diagnostics socket connector	
3	Electric fan solenoid	
4	Injection load solenoid	
5	Water temperature sensor	
6	Throttle body and electronic injection control unit (MIU)	
7	Fuel injector	
8	HV coil	
9	Lambda probe	
10	Fuel pump	
11	Speed sensor	

## Tachometer

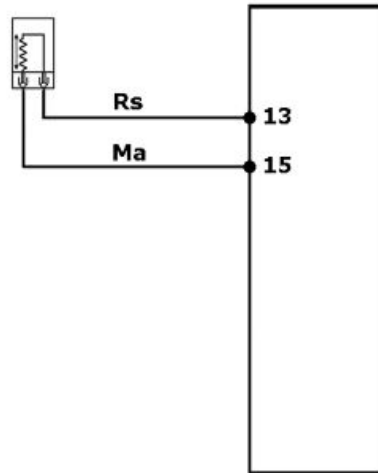

With wiring disconnected from the control unit and connected to the system, check that the sensor resistance between pins 13 - 15 is between 100 and 150 Ohm at an engine temperature of approximately 20°

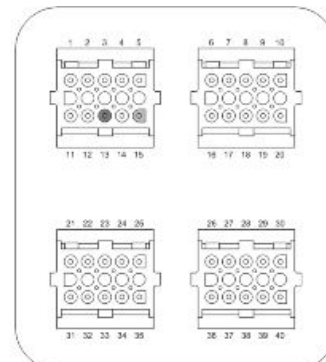

Disconnect the fuel pipe connector. Start up the engine and wait for it to stop. With the wiring connected to the control unit and system try to start up the engine and check that the voltage between pins 13 and 15 is around 2.8 V

With the interface cable harness disconnected from the control unit, check continuity between pin 13 and the red cable of the engine speed sensor connector and between pin 15 and the brown cable of the engine speed sensor connector



With the interface wiring and rpm sensor connector disconnected from the control unit, check that the Red and Brown cables (pin 13 - 15) are isolated from each other and insulated from the ground.

**Specific tooling**

**020481Y Control unit interface wiring**

**020331Y Digital multimeter**

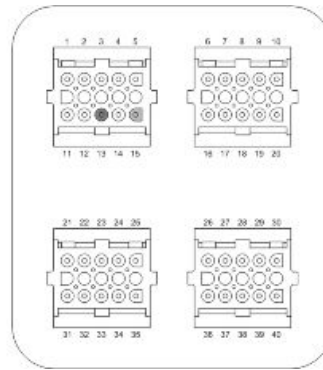

**HT coil**

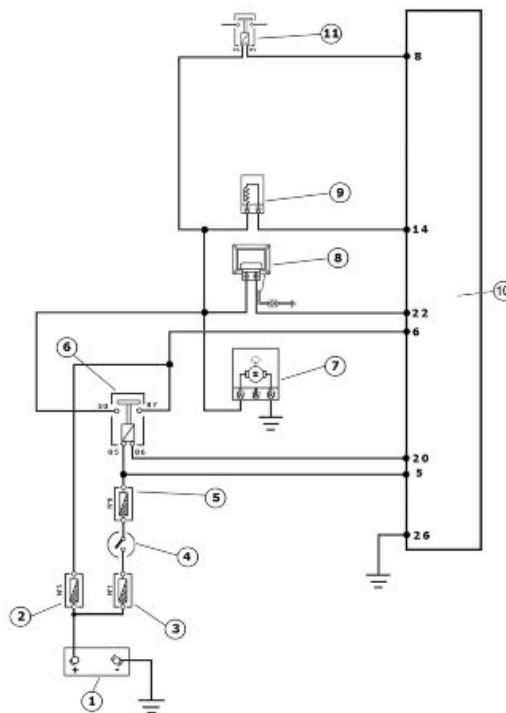

**INJECTION LOADS**

	Specification	Desc./Quantity
1	Battery	12V - 12 Ah
2	Fuse No. 3	10 A
3	Fuse No. 1	30 A
4	Ignition key contacts	
5	Fuse No. 6	5A
6	Injection load solenoid	
7	Fuel pump	
8	HV coil	
9	Fuel injector	
10	Injection ECU	
11	Electric fan solenoid	

The ignition system is integrated with the injection and it is a high-efficiency inductive type ignition.

The control unit manages two important parameters:

- Ignition advance

This is optimised according to the engine rpm, to the engine load, temperature and ambient pressure



With idle engine, it is optimised to obtain the stabilisation of the speed at  $1450 \pm 50$  R/1'.

- Magnetisation time

The coil magnetisation time is controlled by the control unit. The ignition power is increased during the engine start-up phase.

The injection system recognises the 4-stroke cycle and therefore, ignition is only controlled during compression.

## Specific tooling

### 020331Y Digital multimeter

Check function of fuses No. 3 and 6 for the ECU and injection load solenoid.

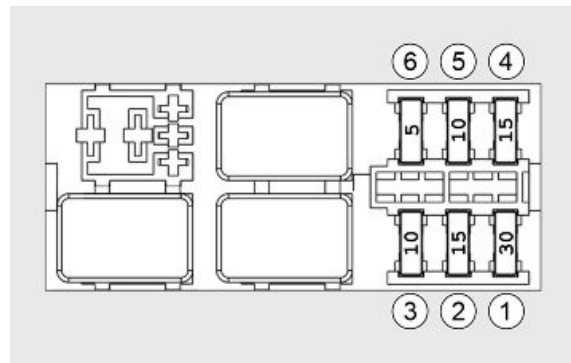
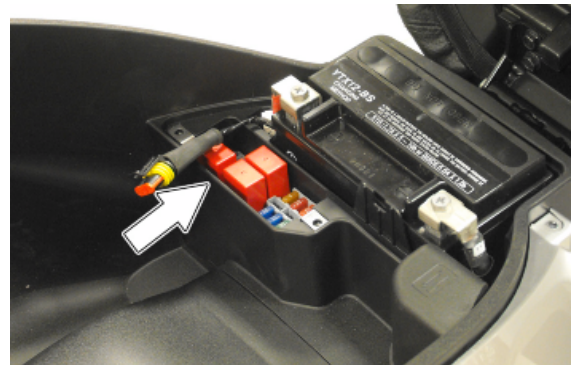

Check the efficiency of the injection load solenoid.

Check the resistance of the energising coil between pins 86 and 85: 40 to 80 Ohm

Apply a voltage of 12V to pins 86 and 85; make sure that there is continuity between pins 30 and 87 of the solenoid.

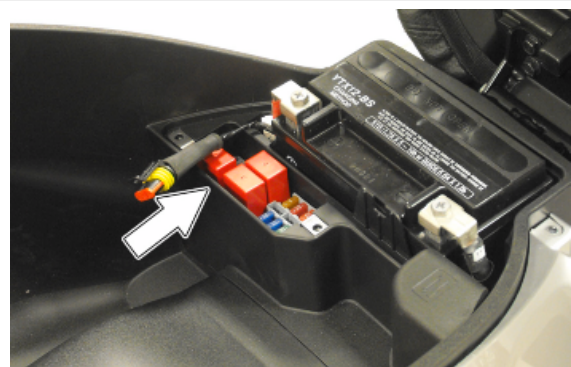

**WARNING**

TO INDICATE THE SOLENOID OF THE DESIRED FUNCTION, REFER TO THE PIN-CABLE COLOUR RELATIONSHIP WITH THE ATTACHED ELECTRIC SYSTEM DIAGRAM.



Check the power supply line of the injection load solenoid energising coil: after switching to «ON», make sure there is battery voltage, for 2 seconds, between the Red-White cable and the Black-Purple cable of the solenoid base. If there is not, check the continuity of the Red-White cable between the fuse box and the solenoid base and of the Black-Purple cable between the pin 20 of the control unit and the solenoid base.

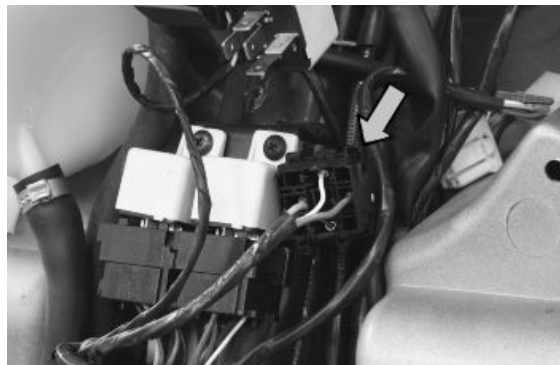

**N.B.**

CONTINUITY TESTS MUST BE CARRIED OUT WITH THE COMPONENTS DISCONNECTED. (SOLENOIDS, CONTROL UNIT, FUSES ETC.).

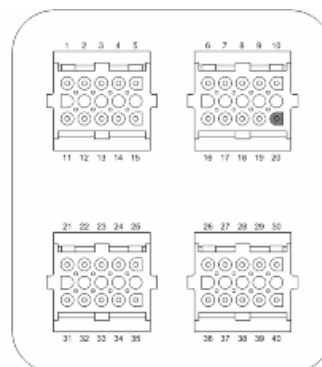

Check for continuous voltage between the grey/black cable of the solenoid base and ground. If no voltage is measured, check continuity of the Grey/Black cable between the fuse box (No. 3, 5A) and the solenoid base.

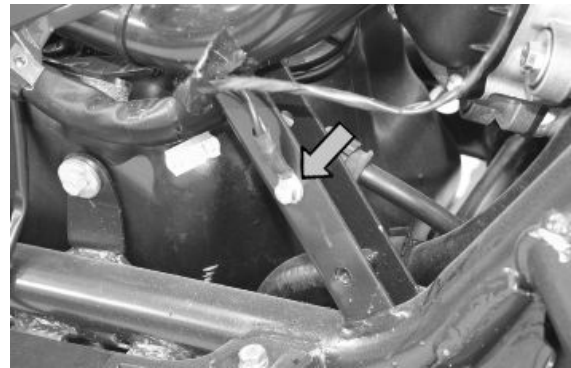

**N.B.**

**CONTINUITY TESTS MUST BE CARRIED OUT WITH THE COMPONENTS DISCONNECTED. (SOLENOIDS, CONTROL UNIT, FUSES ETC.).**

Check there is voltage between pins 22 and 26 of the interface wiring for around two seconds when switching to «ON».

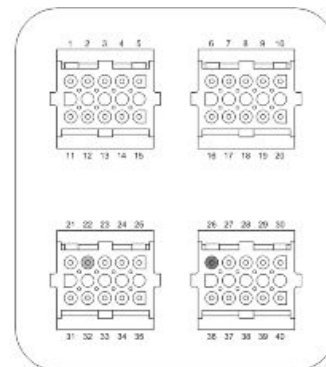

Check the resistance of the primary coil between pin 22 of the interface wiring and the green black cable of the injection load solenoid base with the control unit disconnected and the solenoid disconnected.

Resistance of the primary =  $0.5 \pm 8\%$  Ohm

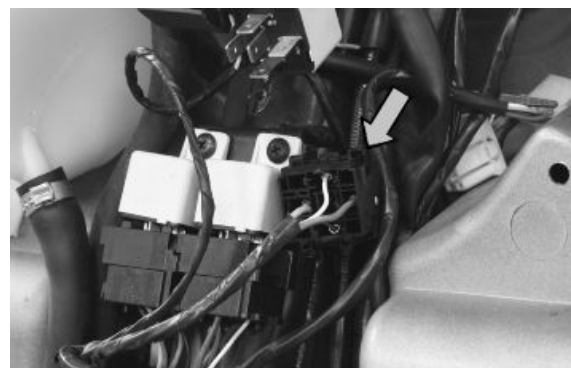
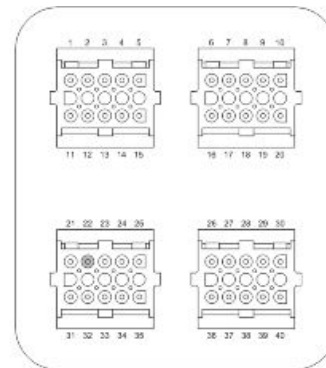

### Coolant temperature sensor

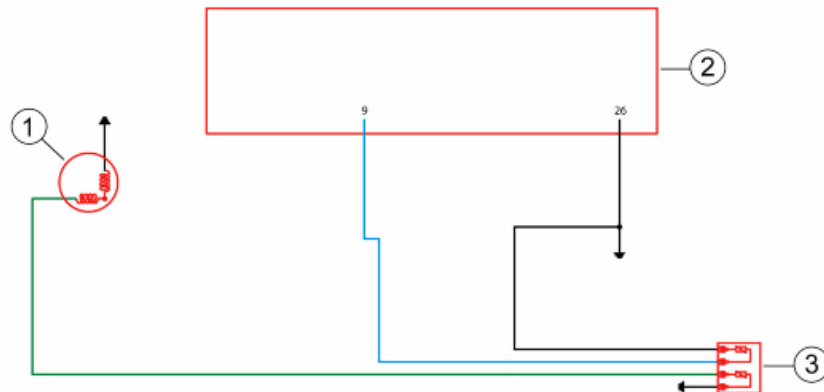

#### TEMPERATURE SENSOR

	Specification	Desc./Quantity
1	Instrument panel	
2	Injection ECU	
3	Water temperature sensor	

With the connector on the control unit side disconnected and the coolant temperature sensor connector connected, check that the resistance values between pin 9 and the ground lead correspond with the engine temperature.

$$20^{\circ} = 2500 \pm 100 \Omega$$

$$80^{\circ} = 308 \pm 6 \Omega$$

With the connector on the control unit side disconnected and the coolant temperature connector disconnected, check the insulation between the light-blue/green cable and ground lead.

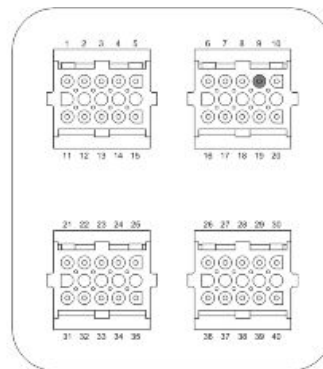

With the connector on the control unit side disconnected and the coolant temperature connector disconnected, check the continuity between pin 9 of the interface cable harness and the light-blue/green cable of the connector.

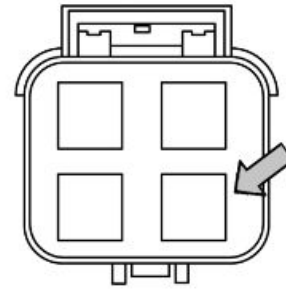

### Specific tooling

**020481Y Control unit interface wiring**

**020331Y Digital multimeter**

## Zeroing the throttle

### Resetting the throttle valve position signal (TPS reset)

The MIU control unit is supplied with a throttle valve position sensor that is pre-calibrated.

Pre-calibration entails regulating the minimum opening of the throttle valve to obtain a certain flow of air under pre-set reference conditions.

Pre-calibration ensures optimal air flow to control idling.

**This regulation must not be tampered with in any way whatsoever.**

The injection system will complete the management of the idling through the Stepper motor and the variation of the ignition advance.

The throttle body after the pre-calibration has an opened valve with an angle that can vary depending on the tolerances of the machining of the pipe and the valve itself.

The valve position sensor can also assume various fitting positions. For these reasons the mV of the sensor with the valve at idle can vary from one throttle body to another.

To obtain the optimum fuel mixture, especially at small openings of the throttle valve, it is essential to match the throttle body with the control unit following the procedure known as TPS resetting.

With this operation we inform the control unit, as the starting point, of the mV value corresponding to the pre-calibrated position.

To reset, proceed as follows.

Connect the diagnostic tester.

Switch to «ON».

Select the functions of the diagnostic tester on «TPS RESET».

### Specific tooling

**020680Y Diagnosis Tool**



Make sure that the throttle valve with the control is supporting the stop screw.



Guaranteeing that this position will be kept, send a confirmation for the TPS reset procedure.



Reset should be performed in the following cases:

- on first fitting.
- if the injection control unit is replaced.

**N.B.**

**THE TPS RESET PROCEDURE MUST NOT BE CARRIED OUT WITH A USED THROTTLE BODY BECAUSE POSSIBLE VALVE WEAR AND STOP WEAR FOR THE MINIMUM OPENING MAKE THE AIR FLOW DIFFERENTLY FROM THAT OF PRE-CALIBRATION.**

Given that the TPS resetting is also done when the control unit is replaced, place the control unit - filter box bellows at 45° during the refitting operation as shown in the picture.

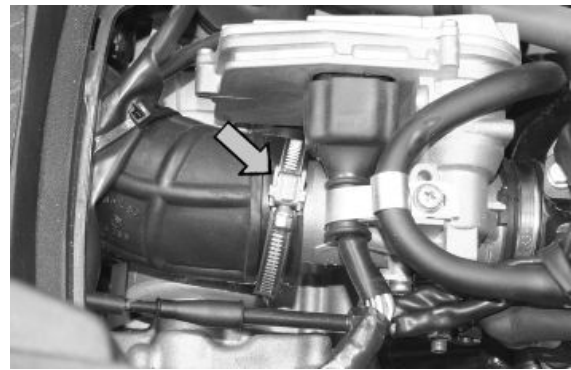

### Lambda probe

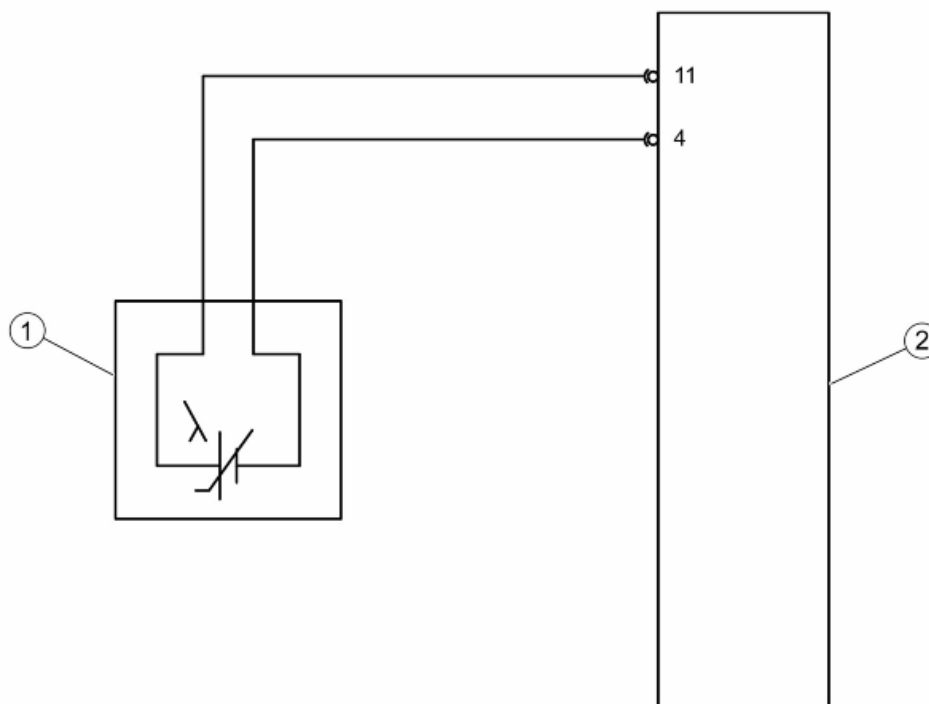

### LAMBDA PROBE

	Specification	Desc./Quantity
1	Lambda probe	
2	Injection ECU	

### PIN RELATIONSHIP

PIN	PIN	Component	Reference value
4	11	Lambda probe	~ 0V with throttle valve closed; ~ 1V with throttle valve fully opened

The Lambda sensor or oxygen sensor is a sensor which provides indications concerning the oxygen content in the exhaust gas. The signal generated is not of the proportional type but of the ON/OFF type, i.e. there is oxygen or there is not. The sensor is positioned on the exhaust manifold before the catalytic converter in an area where the gas temperature is always high. The temperature at which the sensor

works is at least 350°C at 600°C and it has a reaction time of just 50 milliseconds. The signal generated passes from a high value to a low value with a mixture with  $\lambda = 1$ .

### CONTROLLO DEL SEGNALE

Install the electronic control unit interface wiring.

Start the engine and warm up until the electric fan switches on.

Use an analogue multimeter with a direct voltage scale measuring down to 2 V.

Place the tips of the multimeter between pins 4 (-) and 11 (+)

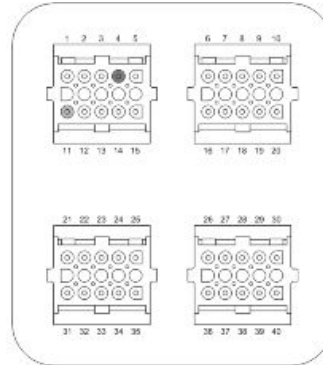

With the engine running at idle speed, check that the voltage oscillates between 0V and 1V

With the throttle valve completely open, the voltage is approx. 1V.

During the closing phase, the voltage is approx. 0V.

If the voltage remains constant, the sensor may be damaged. Remove the sensor and check that there are no oil or carbon deposits inside it..

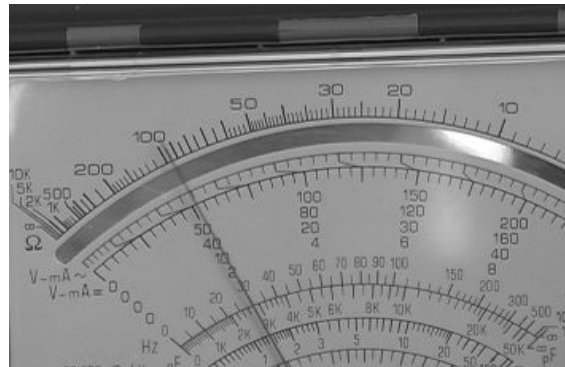



## INDEX OF TOPICS

**SUSPENSIONS**

**SUSP**

---

## Front

---

### Removing the front wheel

- Remove the front brake calliper.
- Loosen the wheel axle lock-nut.



- Loosen the two wheel axle safety screws on the fork leg, on the brake calliper side.



- Pull out the wheel axle.

#### See also

[Removal](#)

---

### Front wheel hub overhaul

Check that the wheel bearings do not show signs of wear.

If you have to replace the wheel bearings, proceed as follows:

- Remove the plastic cover on the tone wheel side to avoid damage by loosening the 5 fixing screws.
- Remove the two bearings on the odometer drive side using the pliers 14 or 34 and the bell detail 9.
- Remove the internal spacer.



\* Either tool can be used.



- Support the front wheel with two wooden shims that make it possible to avoid scratching in the case of contact with the rim.

- Insert the punch (consisting of adaptor handle, 15 mm adaptor and guide) from the odometer drive side to permit the removal of the brake disc side bearing and the spacer bushing.



### Specific tooling

**020376Y Adaptor handle**

**020456Y Ø 24 mm adaptor**

**020412Y 15-mm guide**

- Heat the bearing seat on the side the brake disc with the heat gun.



- Insert the bearing using the punch consisting of adaptor handle, 42x47 mm adaptor and 15 mm guide, and drive it up to the stop.



- 
- Reinsert the spacer bushing on the brake disc side using the appropriate tool and take it to the stop.

**Specific tooling****020376Y Adaptor handle****020359Y 42x47-mm Adaptor****020412Y 15-mm guide****020201Y Spacer bushing driving tube**

- 
- Turn over the wheel and insert the internal spacer with the part fitted with the Seeger ring facing the bearing on the brake disc side installed previously.



- 
- Heat the bearing seat on the odometer drive side with the heat gun.



- 
- Insert the two bearings using the punch consisting of adaptor handle, 32x35 mm adaptor and 15 mm guide, and drive it up to the stop.

**Specific tooling****020376Y Adaptor handle****020357Y 32x35-mm Adaptor****020412Y 15-mm guide**

---

## Refitting the front wheel

- Grease the wheel axle, then install it from the tone wheel side and install the tone wheel properly.
- Tighten the wheel axle nut to the prescribed torque.

**N.B.**

**TAKE CARE NOT TO DAMAGE THE ODOMETER DRIVE. FOR THE SAKE OF SAFETY, OFFSET THE INTERNAL STOP FROM THE STOP OF THE TONE WHEEL BY 90°.**



- Tighten the two safety screw on the leg to the prescribed torque.

**Locking torques (N\*m)**

**Front wheel axle nut 45 - 50 Safety screw on fork leg 6 - 7**



---

## Handlebar

---

### Removal

- Remove the rear handlebar cover.
- Remove the pin mounting the handlebar to the steering tube.
- Remove the handlebar and place it on the rear cover of the legshield.

**See also**

[Rear handlebar cover](#)

## Refitting

- Install the handlebar on the steering tube, paying attention to the centring, aligning the recess on the handlebar with that on the steering tube as shown in the figure.
- Tighten the handlebar fixing screw on the steering tube to the prescribed torque.



### Locking torques (N\*m)

**Handlebar fixing screw (\*) 45 to 50**

(\*) Lubricate the nuts with engine oil before installation

## Front fork

### Removal

### Overhaul

- Support the fork in a vice.
- Loosen the two tightening screws of the stem supporting clamp.
- Unscrew the stem closing cap and slide off the complete fork leg from the corresponding support.

#### CAUTION

THE STEM CLOSING CAP KEEPS THE MAIN SPRING PRE-LOADED. KEEP THE CAP PROPERLY FITTED DURING THE REMOVAL FINAL STAGE TO AVOID ACCIDENTS.

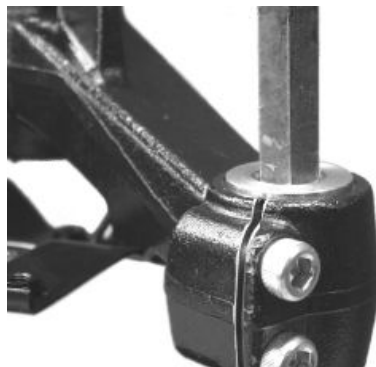

- Support the fork leg properly, remove the main spring and drain off the fork leg oil.



- Remove the hydraulic rod fixing screw with the corresponding sealing gasket:
- With a 19-mm hexagonal spanner, lock hydraulic rod rotation.
- Undo the fixing screw and collect the copper washer.

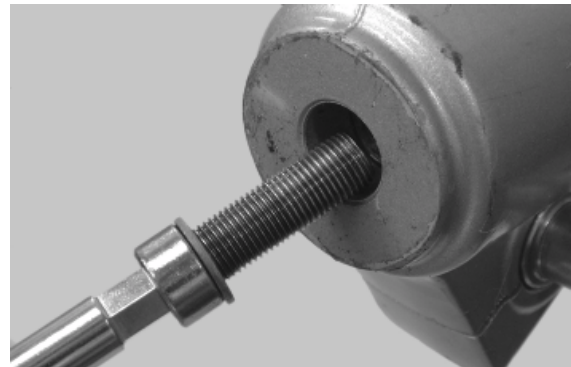
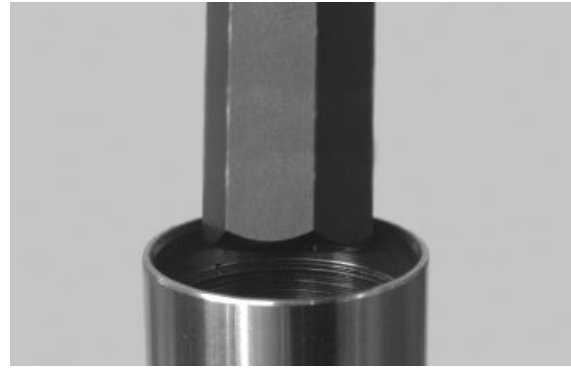

- Remove the stem dust guard with a screwdriver.

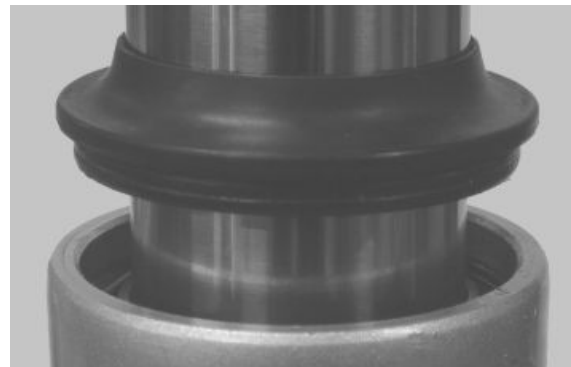

- Remove the circlip retaining the oil seal.

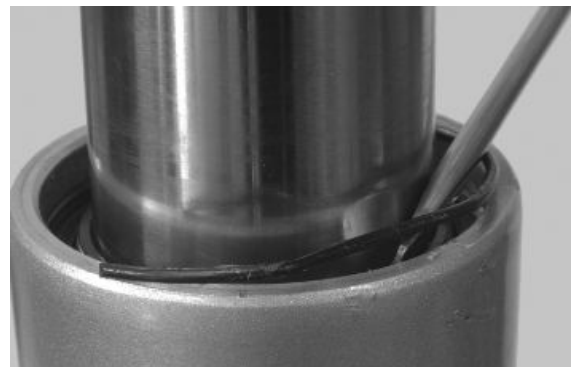

- 
- Take out the stem.



- Check there are no signs of wear or seizing between the stem and the fork leg. Otherwise, replace the damaged parts.

**Characteristic****Maximum fork leg diameter**

35.10 mm

**Minimum stem diameter**

34.90 mm

- 
- Take out the oil seal using the appropriate tools.
  - Fit the tie rod into the oil seal.
  - Insert in sequence the two half-rings per Ø 35-mm stems.

**Specific tooling****020487Y Fork oil seal extractor**

- 
- Hold the tie rod manually so that it does not fall into the fork leg and/or that both half-rings are not in their position.
  - Fit the bell.
  - Tighten the nut until it stops.
  - Act on the tool until the oil seal is completely removed.

**Specific tooling****020487Y Fork oil seal extractor**



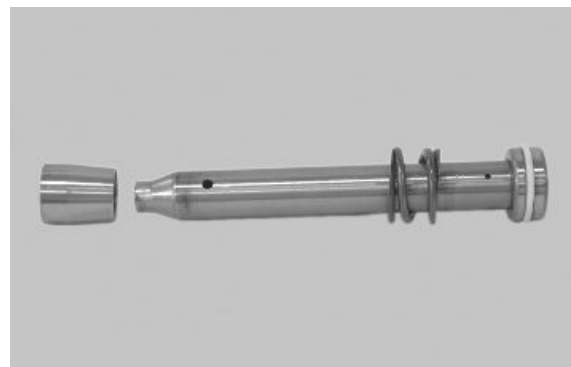

- Remove the hydraulic rod with the corresponding sealing gasket, the spring and the stop bushing.

**COMPONENT CHECK****CAUTION****CLEAN ALL THE COMPONENTS THOROUGHLY.**

- Check that the fork leg is not cracked or broken in the attachments.
- Check that the stem is not scored, dented or distorted.
- Check that the stop bushing for the hydraulic rod is correctly fixed through caulking.

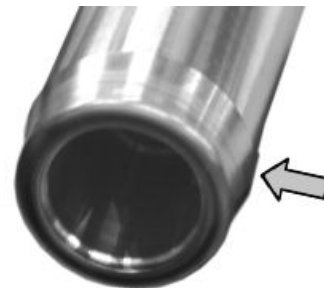

- 
- Check that hydraulic rod caulking, the return spring to the unloaded the end of stroke and the hydraulic rod sealing ring are in good conditions.

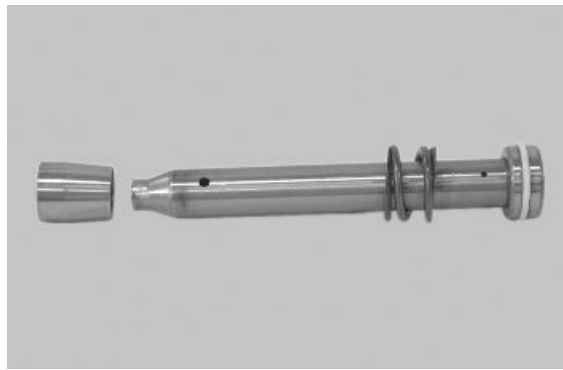

- 
- Check that the main spring exhibits no signs of yielding or abnormal wear.



- 
- Check that the closing cap O-ring of the stem is in good conditions.



---

## Refitting

- 
- First grease the splitting chamber of the two sealing lips of a new oil seal.
  - Fit the sealing ring on the stem and keep the identification words facing upwards.
  - Drive the oil seal as far as it will go using the appropriate tool.

### Specific tooling

**020376Y Adaptor handle**

**020359Y 42x47-mm Adaptor**



- Pre-fit the stem with the hydraulic rod, the spring and the stop bushing.
- Fit the pre-assembled components inside the fork leg.



- Fit the hydraulic rod fixing screw with the copper sealing washer and tighten to the prescribed torque using the recommended product.

**CAUTION**

**ALWAYS USE NEW COPPER WASHER.**

**Locking torques (N\*m)**

**Hydraulic rod fixing screw 25 ÷ 35\***

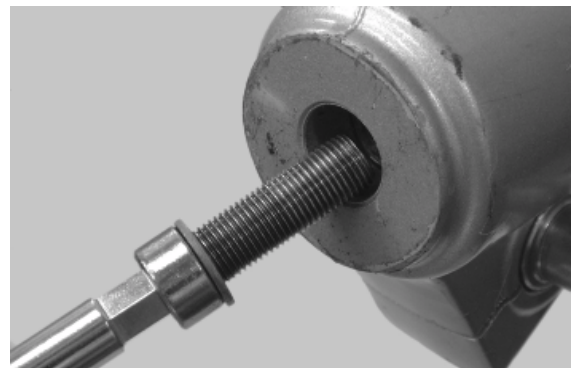

(°) Apply LOCTITE 243 threadlock

- Lock hydraulic rod rotation using a 19-mm hexagonal spanner.



- Fit the oil seal retaining circlip.



- Grease and fit a new dust guard.

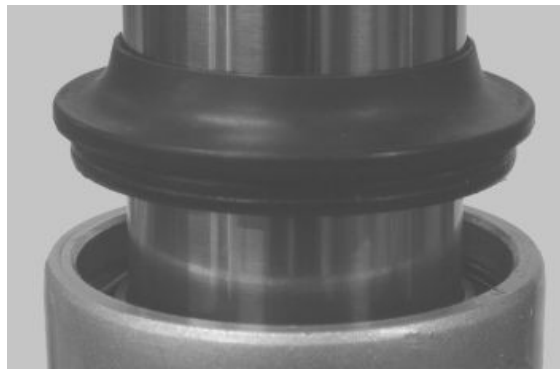

- Fit the fork leg together with the stem on the fork supporting clamp until it stops.
- Tighten the two screws to the prescribed torque in the sequence indicated in the picture.



**Locking torques (N\*m)**

**Stem support clamp tightening screws 20 to 25**

- Refill the fork leg with the recommended product to the prescribed amount.

**Recommended products**

**AGIP FORK 7.5 W Oil for front fork**

Hydraulic fluid SAE 7.5 W

**Characteristic**

**Oil quantity per stem**

133 ± 3 cm<sup>3</sup>



- Bleed the hydraulic rod by actuating the stem repeatedly.
- Fit the spring into the stem.



- Lubricate the closing cap O-ring of the stem.
- Preload the spring, fit the closing cap and tighten to the prescribed torque.

**Locking torques (N\*m)****Fork locking screws cap  $15 \div 30$** 

- Repeat the procedure for the other fork leg.

**N.B.****IF BOTH FORK LEGS ARE SERVICED AT THE SAME TIME, BE CAREFUL NOT TO INVERT THE RIGHT FORK LEG WITH THE LEFT ONE.**

---

**Steering column**

---

**Removal**

- Remove the front wheel.
- Remove the front mudguard
- Remove the front brake calliper
- Remove the front and rear handlebar covers.
- Remove the pin mounting the handlebar to the steering tube.
- Remove the handlebar and rest it on the shield back plate.

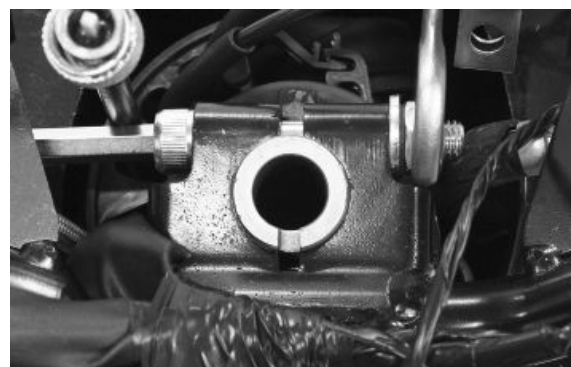

- Remove by releasing the cable passages and sliding the protection collar upwards.

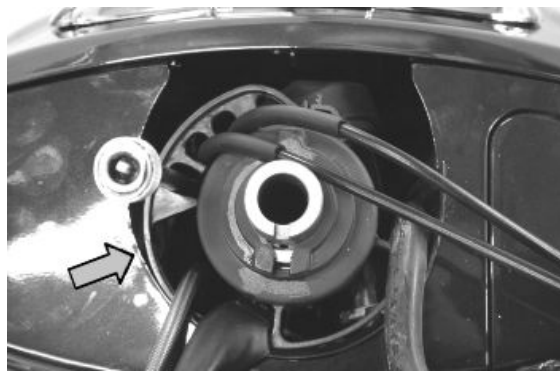

Using the special tool, loosen and remove the upper ring nut, the spacer washer and the counterlock ring.

- Extract the fork.

**N.B.**

**TAKE CARE TO SUPPORT THE FORK SO AS TO PREVENT IT FROM COMING OFF ABRUPTLY**

**Specific tooling**

**020055Y Wrench for steering tube ring nut**



**Refitting**

- Fit the lower steering bearing on the steering tube.
- Fit the fork together with the lower steering bearing on the headstock and hold it so that it does not fall.

**N.B.**

**LUBRICATE THE STEERING FIFTH WHEEL TRACKS WITH RECOMMENDED GREASE BEFORE USE.**

**Recommended products**

**AGIP GREASE PV2 Grease for steering bearings, bolt seatings for swinging arms and faying surface of driven pulley spring (only pulley side)**

Soap-based lithium and zinc oxide grease containing NLGI 2; ISO-L-XBCIB2

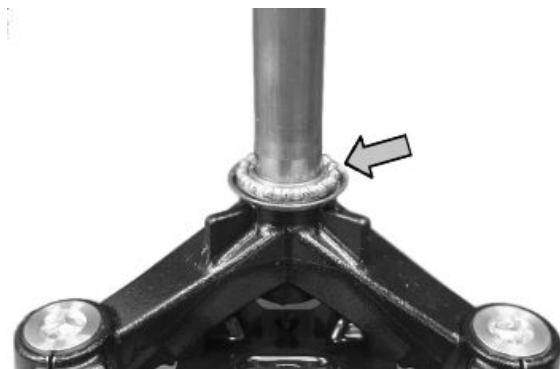

- 
- Fit the upper steering bearing.

**CAUTION**

**INSERT THE UPPER STEERING BEARING WITH THE CAGE FACING UPWARDS.**



- 
- Fit the steering bearing upper seat.



- 
- Fit the cover plate.



- 
- Insert the lower tightening ring nut, screw until it stops and, with the specific tool, tighten to the prescribed torque.

**Specific tooling**

**020055Y Wrench for steering tube ring nut**

**Locking torques (N\*m)**

**Steering tube lower ring nut 14 ÷ 17**





- Fit the spacer between the two ring nuts on the steering tube in the position indicated.



- Insert the upper tightening ring nut, screw until it stops and, with the specific tool, tighten to the indicated torque.

**Specific tooling**

**020055Y Wrench for steering tube ring nut**

**Locking torques (N\*m)**

**Steering tube upper ring nut 40 ÷ 45**

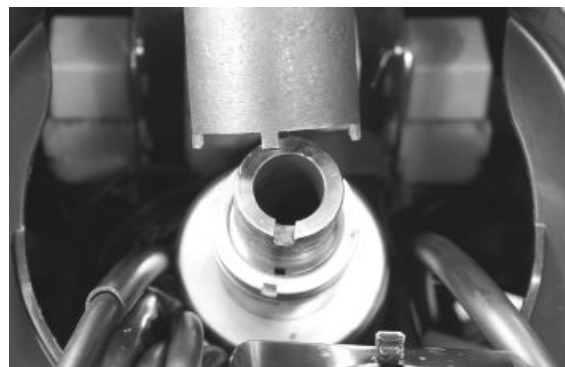



---

Insert the collar shown in the figure and restore the cable passage as shown in the figure.

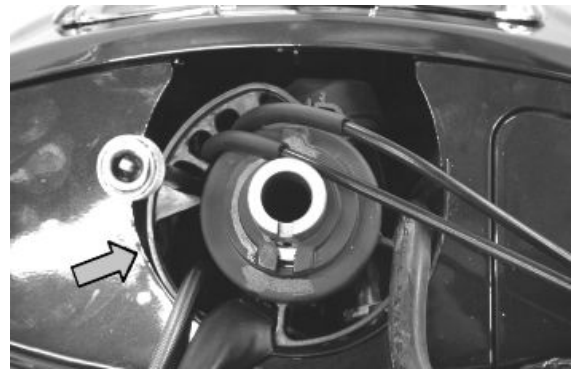

- Fit the front wheel.

---

## Steering bearing

---

### Removal

- Clean thoroughly and visually inspect if the components are in good conditions.
- Check the upper steering bearing for wear.



- Check the lower steering bearing for wear.



- Visually inspect that the steering fifth wheel tracks, the headstock and the steering tube exhibit no scores or abnormal wear. Otherwise, replace them.

#### **STEERING FIFTH WHEEL TRACK REMOVAL**

- Remove the steering fifth wheel tracks on the chassis with the specific tool, following the indicated procedure.
- Fit the specific tool from the lower part of the headstock until it makes contact with the upper track.
- Hit with force the specific tool, placing it at different points diametrically opposed so as to remove the upper track.

#### **Specific tooling**

**020004Y Punch for removing steering bearings from headstock**

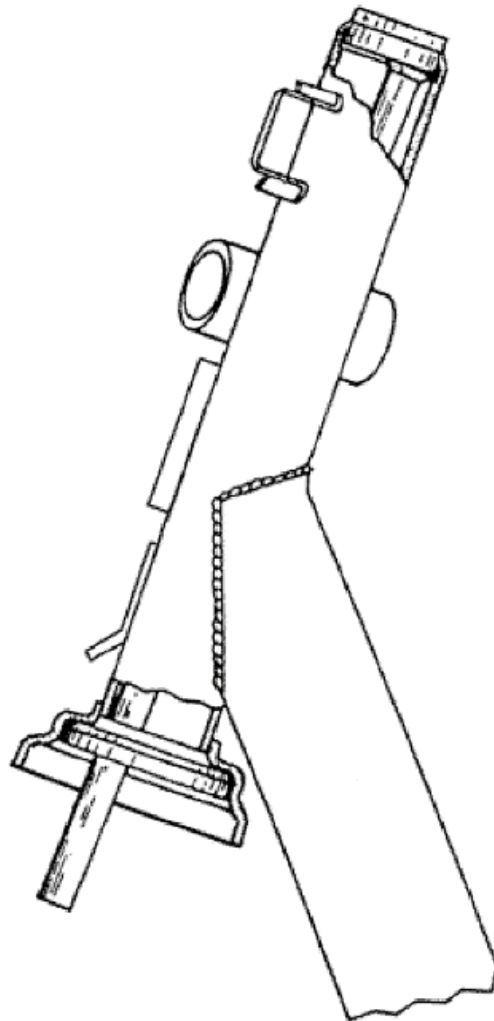
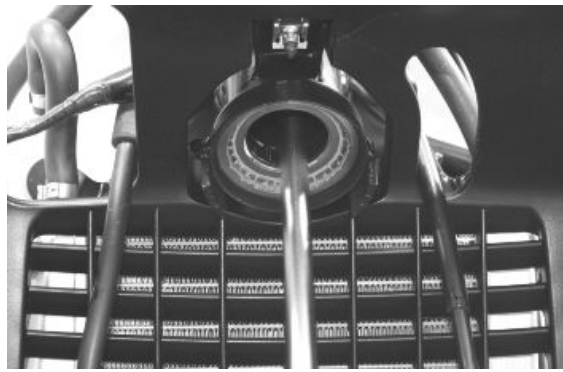

- Repeat the procedure for the lower steering bearing track.

- Remove the lower steering bearing seat on the steering tube using the specific tool.

### Specific tooling

**020004Y Punch for removing steering bearings from headstock**

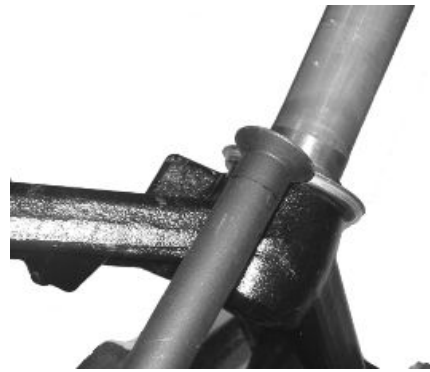

## Refitting

### STEERING FIFTH WHEEL TRACK FITTING

- Thoroughly clean the track seats on the headstock and the steering tube.
- Fit the new tracks of the headstock with the specific tool.
- Screw the nut until the tracks are fully inserted.

**N.B.**

**LUBRICATE THE STEERING FIFTH WHEEL TRACKS WITH RECOMMENDED GREASE BEFORE USE.**

### Specific tooling

**001330Y Tool for fitting steering seats**

**001330Y014 Tool for fitting steering seats**

**001330Y015 Tool for fitting steering seats**

### Recommended products

**AGIP GREASE PV2 Grease for steering bearings, bolt seatings for swinging arms and faying surface of driven pulley spring (only pulley side)**

Soap-based lithium and zinc oxide grease containing NLGI 2; ISO-L-XBCIB2

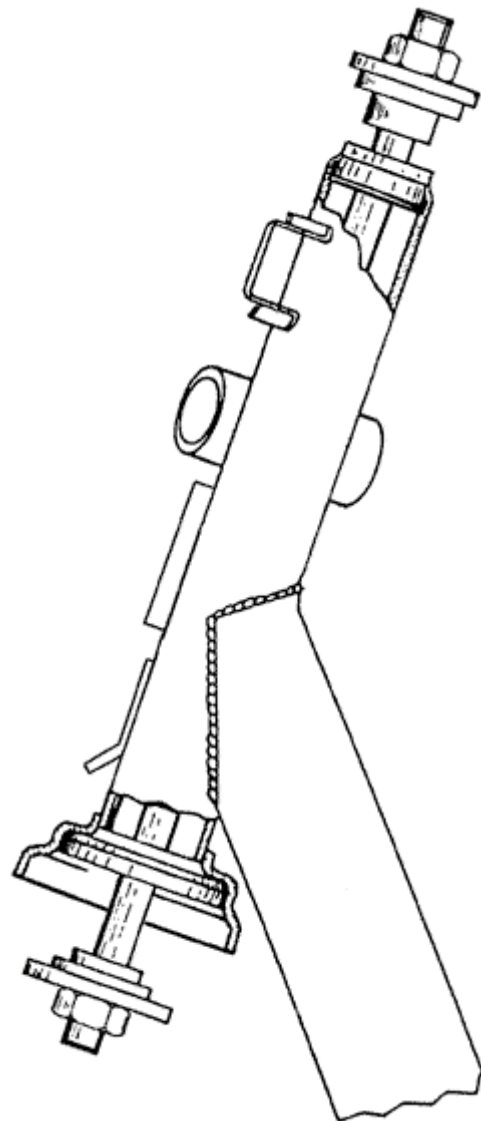

- Fit the lower steering bearing seat on the steering tube.
- With a tube of the indicated sizes, fit the lower seat until it stops. Inside Ø: 35.5 mm; Outside Ø: 38 mm; Length: 350 mm.

**N.B.**

LUBRICATE THE STEERING FIFTH WHEEL TRACKS WITH RECOMMENDED GREASE BEFORE USE.

**Recommended products**

**AGIP GREASE PV2 Grease for steering bearings, bolt seatings for swinging arms and faying surface of driven pulley spring (only pulley side)**

Soap-based lithium and zinc oxide grease containing NLGI 2; ISO-L-XBCIB2

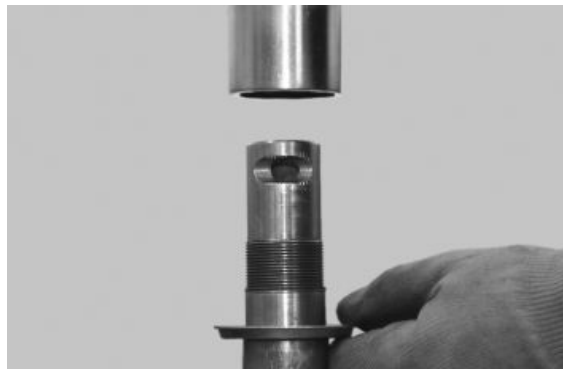

---

**Rear**

---

**Removing the rear wheel**

- Remove the silencer mounting bracket;
- Retrieve the conical spacer and remove the wheel.

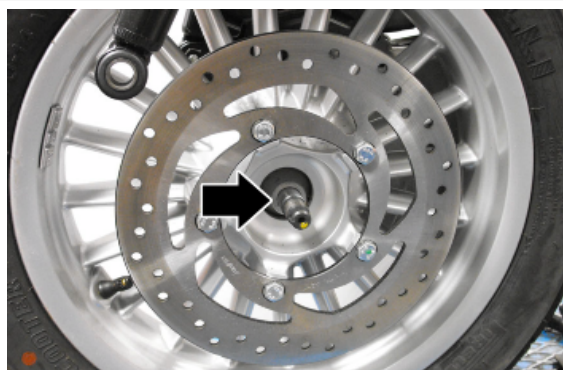

---

**Refitting the rear wheel**

- Carry out the removal operations but in reverse order, observing the prescribed tightening torques.

**Locking torques (N\*m)**

Fixing screw for wheel rim to hub 33 - 37

---

**Swing-arm**

---

---

## Removal

- Place the vehicle on its centre stand;
- Support the engine adequately;
- Loosen the nut shown in the figure and pull out the pin from the left-hand side.



- Loosen the nut and lock nut on the left-hand side of the scooter (see figure) and unscrew the pin from the opposite side.
- Remove the retaining screw of the rear brake pipe shown in the figure.



- Loosen the nut on the inside of the frame from the left-hand side (see figure) and remove the relevant pin;
- Remove the swinging arm.



---

## Overhaul

- Check that the silent bloc is not damaged. If there is, replace it.
- Remove the Seeger ring shown in the picture



- Remove the full silent bloc bracket
- Hold the full silent bloc bracket in the clamp
- Using the appropriate tool, remove the silent bloc from the bracket from the side corresponding to the inside of the vehicle. This is to guarantee the tool is centred properly on the support

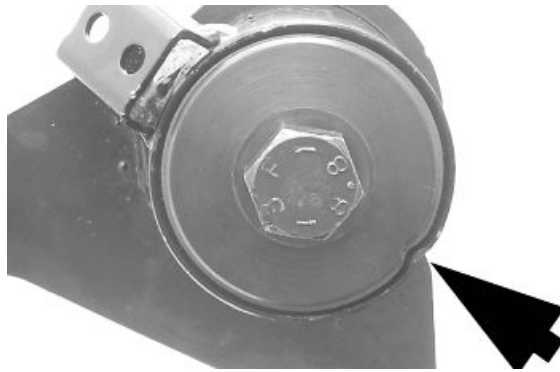

**Specific tooling**

**020271Y Tool for removing-fitting silent bloc**



- Install a new silent bloc, making sure it aligns properly with the reference tooth.
- Fit the silent blocs, making sure the chamfered part of the silent bloc matches the chamfered part of the bracket

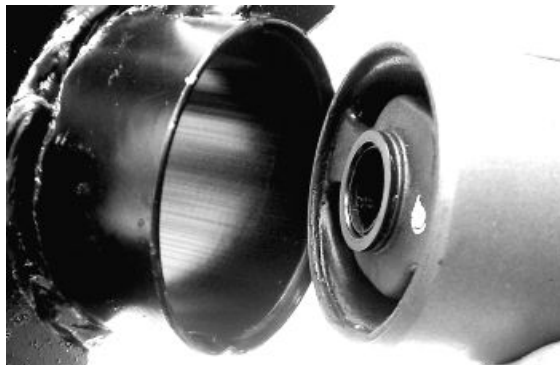

- Using the appropriate tool, fit the silent bloc as shown in the picture

**Specific tooling**

**020271Y Tool for removing-fitting silent bloc**



- Check there is no sticking in the movement of the connection of the swinging arm on the engine side to the swinging arm on the frame side.
- Check the axial clearance between the two swinging arms using a feeler gauge

### Characteristic

#### Allowable limit after use:

1 mm

#### standard clearance

0.40 ÷ 0.70 mm

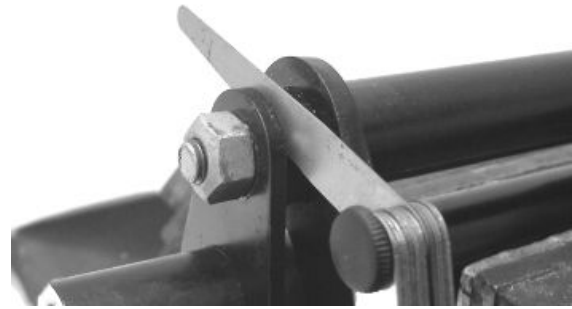

- In order to check the clearance of the swinging arm on the frame side, prepare a retainer using the fixing pin of the swinging arm on the frame and two rings from the special tool 020229Y.

Alternatively, use two washers with inside diameter of 12 mm for pins, outside diameter min. 30 mm and thickness min. 4 mm.



- Separate the swinging arm on the engine side from the vehicle side arm.
- Remove the internal spacer shown in the picture

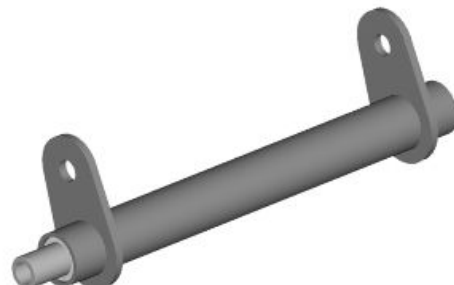

- Using a suitable pin remove the roller casings as shown in the pictures



- Using an appropriate tool plant new roller casings, being careful to position the bearings with the O-rings facing outwards

**Specific tooling**

**020115Y Ø 18 punch**

**020244Y 15-mm diameter punch**



**SWINGING ARM SERVICE**

Specification	Desc./Quantity
Length of the internal swinging arm spacer on the frame side	<b>228</b> -0.2/-0.4 mm
Length of the internal swinging arm spacer on the engine side	<b>183</b> 0/-0.2 mm
Length of the swinging arm tube on the engine side	<b>182.5</b> -0.1/-0.3 mm
Length of the swinging arm tube on the frame side	<b>227.1</b> +0.2/0 mm

- Lubricate the roller bearing housings with grease
- Insert the spacers
- Assemble the two arms with the relative bolt in the position shown in the picture
- Adjust the bolt as shown in the picture
- Position the frame side swinging arm with the most protruding part pointing towards the silent block side as shown in the picture



**Recommended products**

**AGIP GREASE PV2 Grease for control levers on the engine**

White anhydrous-calcium based grease to protect roller bearings; temperature range between -20 °C and +120 °C; NLGI 2; ISO-L-XBCIB2



## Refitting

In order to fit the swinging arm properly, follow these steps:

- Position the silent block support bracket with part «3 » pre-fitted and screw in but do not tighten part «1».

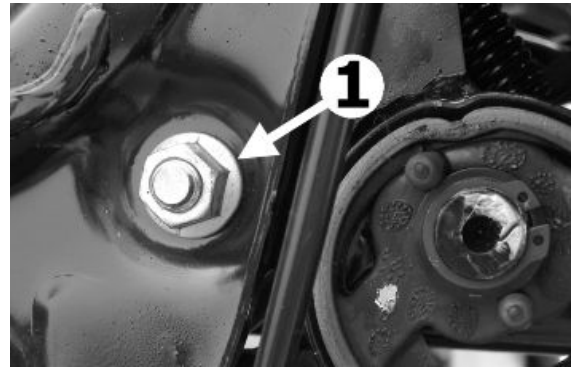

- Position the swinging arm, inserting part « 2 ».

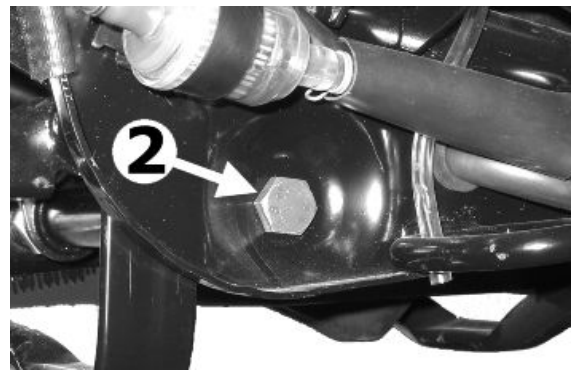

- Tighten part «3» to the prescribed torque.

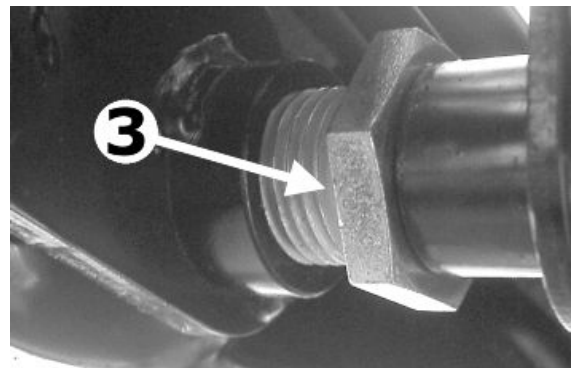

- Screw and tighten part «4» to the prescribed torque.



- Screw and tighten part «5» to the prescribed torque.



- Tighten part «1» to the prescribed torque.

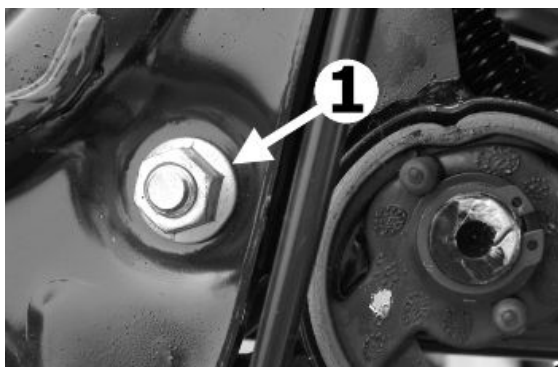

- Insert the swinging arm - engine pin and tighten to the prescribed torque.



**SWINGING ARM FITTING**

Name	Torque in Nm
Part 1	64 - 72
Part 3	5 - 7
Part 4	90 - 110
Part 5	50 ÷ 55
Engine-swinging arm pin	55 ÷ 61

**Shock absorbers**

---

## Removal

Proceed as follows:

- place the vehicle on its centre stand;
- lift the engine a little with a jack so as to free the two shock absorbers;
- remove the silencer
- undo the shock absorber spring assembly clamping screw from the support fixed to the engine on the one side and from that fixed to the silencer on the other;
- unscrew the two upper nuts (one on each side) fixing the shock absorber spring assembly to the frame and remove the shock absorbers.

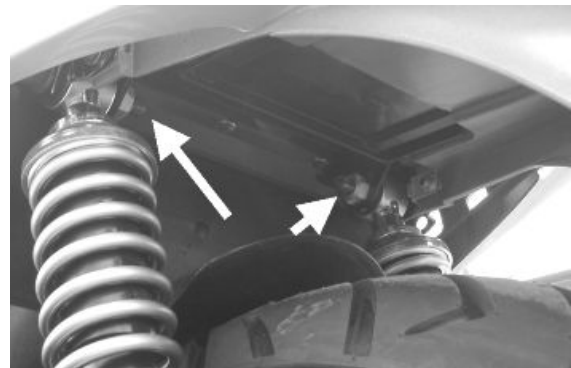

### See also

[Exhaust assy. Removal](#)

---

## Refitting

Carry out the previous operations but in reverse order.

### Locking torques (N\*m)

Left shock absorber lower retainer 33 ÷ 41 Right shock absorber lower retainer 40 ÷ 45 Upper shock absorber retainer 40 ÷ 45

---

## Exhaust bracket

---

### Removal

- Remove the silencer;
- Disconnect the connector from the speed sensor;

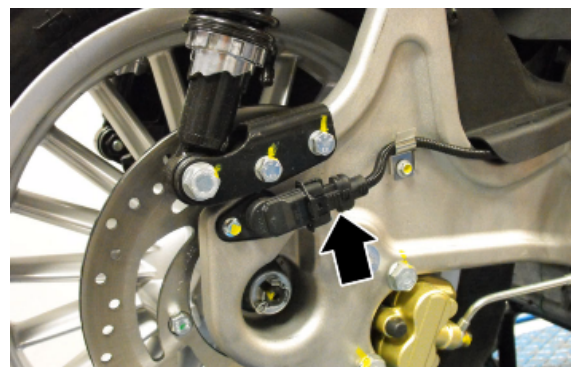

- Unscrew the lower bolt fastening the right hand shock absorber, remove the shock absorber from its seat and retrieve the shim;

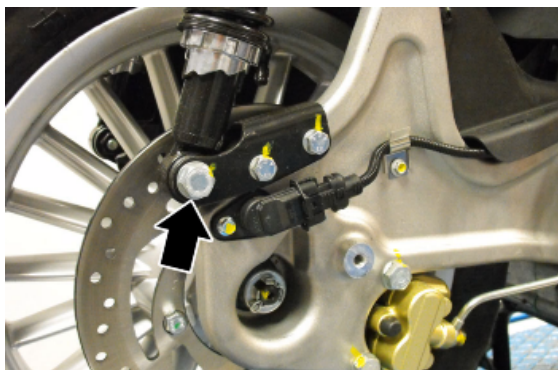

- Unscrew the screw indicated in the figure and release the rear brake hose from the silencer mounting bracket;

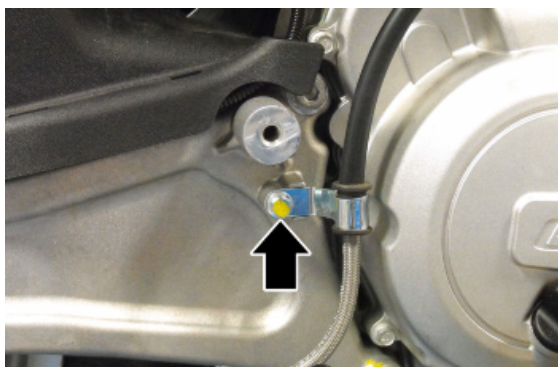

- Unscrew the two bolts fastening the rear brake calliper to the silencer mounting bracket;

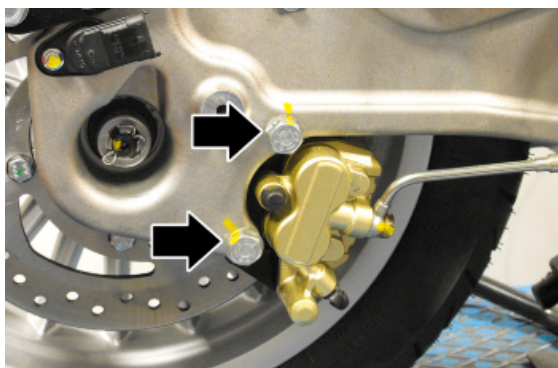

- Unscrew the two screws fastening the rear mud-guard indicated in the figure;

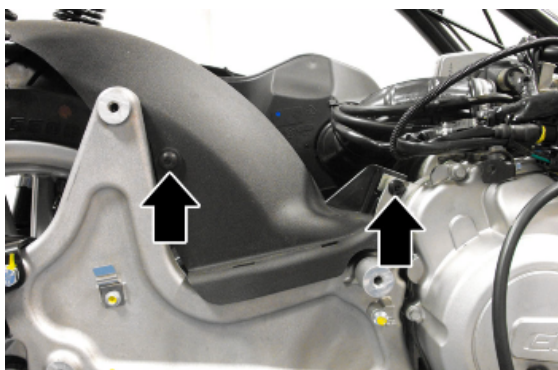

- Working from the left hand side of the vehicle, unscrew the two screws indicated and remove the rear mudguard;

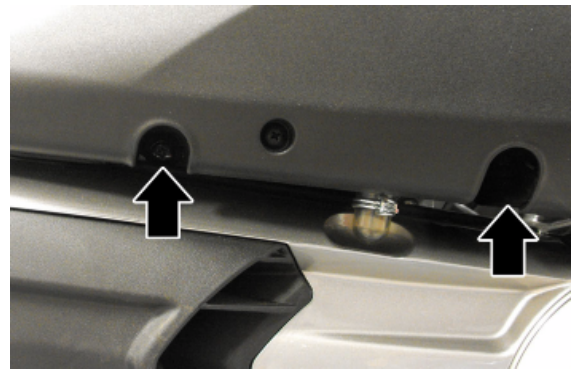

- Remove the safety split pin, aligning with the recess on the bracket. Remove the nut cap;

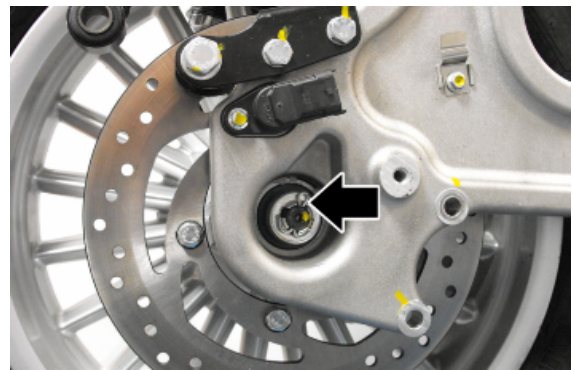

- Undo the nut fastening the rear wheel;

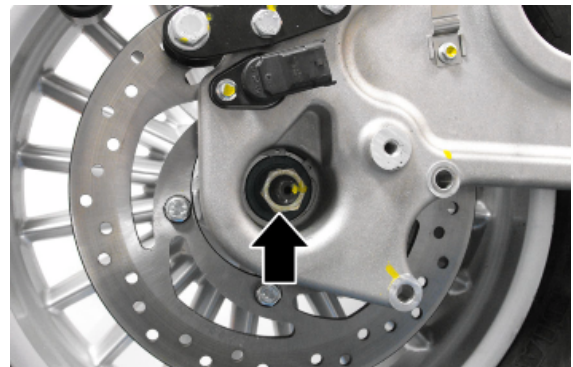

- Unscrew the two screws fastening the silencer mounting bracket to the engine, as indicated in the figure, and remove the bracket.

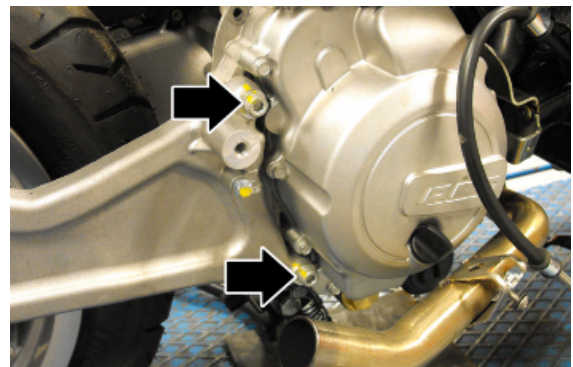

### See also

[Exhaust assy. Removal](#)

## Overhaul

- Remove the circlip shown in the picture

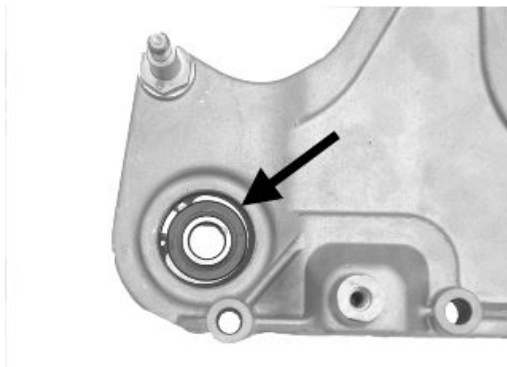

- Support the silencer support bracket sufficiently
- Using the special punch, remove the bearing from its seat as shown in the picture

### Specific tooling

020376Y Adaptor handle

020456Y Ø 24 mm adaptor

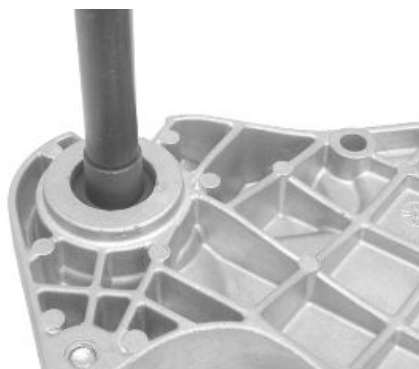

- Heat the bearing seat using the heat gun
- Using the special punch, install a new bearing in the seat as shown in the picture

### Specific tooling

020376Y Adaptor handle

020151Y Air heater

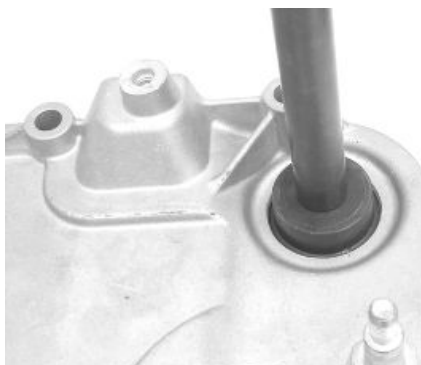

## Refitting

To refit, carry out the removal operations in reverse order, observing the prescribed tightening torques.

N.B.



**THE TIGHTENING MUFFLER MOUNTING ARM MUST BE TIGHTENED AFTER TIGHTENING THE WHEEL.**

### Locking torques (N\*m)

Rear wheel axle nut 104 to 126 Silencer supporting arm to engine screws (\*) 20 to 25 Right shock absorber lower retainer 40 ÷ 45

---

**Centre-stand**

- Remove the two return springs from the centre stand.
- Undo the nut shown in the figure.
- Remove the pin from the right side.
- Remove the centre stand.
- On refitting tighten the nut to the specified torque.

**Locking torques (N\*m)****Centre stand bolt 40 ÷ 45**

---

**Side stand****Removal of the side stand**

- Unhook the springs;
- Loosen the nut;
- Pull out the screw;

**Fitting**

Carry out the previous operations but in reverse order.

**Locking torques (N\*m)****Side stand fixing bolt 40 ÷ 45**

## INDEX OF TOPICS

**B**RAKING SYSTEM

**BRAK SYS**



This section è is dedicated to the description of the braking system components.

---

## **Interventions rules**

### **WARNING**

**BRAKING SYSTEM FLUID IS CORROSIVE: ALWAYS WEAR PROTECTIVE GLOVES. IN THE EVENT OF ACCIDENTAL CONTACT WITH YOUR EYES, RINSE THE CONTACT AREA WELL WITH ABUNDANT WATER.**

**THE BRAKE FLUID DRAINED FROM THE SYSTEM IS HARMFUL TO THE ENVIRONMENT. COLLECTION AND DISPOSAL MUST BE CARRIED OUT IN COMPLIANCE WITH THE REGULATIONS IN FORCE. UNDER NORMAL DRIVING AND CLIMATIC CONDITIONS YOU SHOULD CHANGE THE FLUID EVERY TWO YEARS. IF BRAKES ARE USED INTENSELY AND/OR IN HARSH CONDITIONS, CHANGE THE FLUID MORE FREQUENTLY.**

**DURING INSTALLATION, THE PARTS TO BE REUSED MUST BE ABSOLUTELY CLEAN AND FREE FROM ANY TRACES OF OIL, FUEL AND GREASE: IT IS THEREFORE NECESSARY TO CLEAN THEM THOROUGH WITH DENATURED ALCOHOL.**

### **N.B.**

**FOR TOPPING UP AND CHANGE, USE ONLY BRAKE FLUID DOT4 - NHTSA 116.**

**OBSERVE THE MAXIMUM DEGREE OF CLEANLINESS. HYDRAULIC FLUID IS EXTREMELY CORROSIVE FOR PAINTED SURFACES.**

**BRAKE FLUID IS HYGROSCOPIC; THAT IS, IT ABSORBS MOISTURE FROM THE SURROUNDING AIR.**

**IF THE MOISTURE CONTENT IN THE BRAKE FLUID EXCEEDS A CERTAIN VALUE, IT WILL RESULT IN POOR BRAKING EFFICIENCY DUE TO A LOW BOILING POINT OF THE FLUID.**

### **N.B.**

**ALWAYS USE FLUID FROM SEALED CONTAINERS.**

### **N.B.**

**RUBBER PARTS SHOULD NEVER BE LEFT IN ALCOHOL LONGER THAN 20 SECONDS. AFTER WASHING, THE PIECES MUST BE DRIED WITH A BLAST OF COMPRESSED AIR AND A CLEAN CLOTH.**

**THE SEAL RINGS MUST BE IMMERSSED IN THE OPERATING FLUID; THE USE OF PRF1 PROTECTIVE DEVICE IS ALLOWED.**

### **WARNING**

**THE PRESENCE OF BRAKE FLUID ON THE DISC OR BRAKE PADS REDUCES BRAKING EFFICIENCY. IN THIS CASE, REPLACE THE PADS AND CLEAN THE DISC WITH A HIGH-QUALITY SOLVENT.**

---

## **Rear brake calliper**

---

---

## Removal

- Remove the rear wheel.
- Remove the two rear brake calliper devices fastening them to the support as shown in the picture.

**N.B.**

SHOULD THE BRAKE CALLIPER BE REPLACED, BEFORE REMOVING THE FITTINGS FIXING THE CALLIPER TO THE SUPPORTING BRACKET, FIRST LOOSEN THE OIL HOSE FITTING AFTER HAVING EMPTIED THE SYSTEM OF THE CIRCUIT BEING INSPECTED.

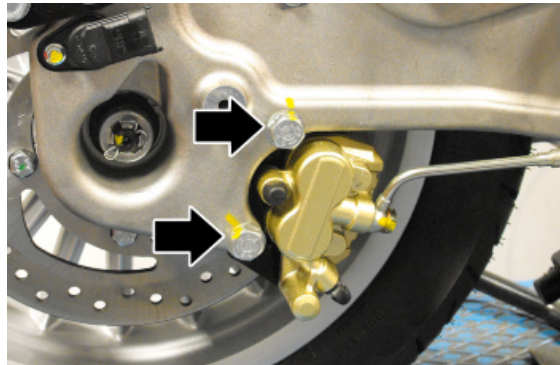

---

## Refitting

- Follow the removal procedures but in reverse order and tighten to the prescribed torques with the recommended product.

### Recommended products

#### Loctite 243 Medium strength threadlock

Medium Loctite 243 threadlock

### Locking torques (N\*m)

#### Screw tightening calliper to support 20 to 25

If the calliper is replaced:

**CAUTION**

**ONCE REFITTING IS FINISHED, BLEED THE SYSTEM.**

**CAUTION**

**ALWAYS USE NEW COPPER WASHERS.**

### Locking torques (N\*m)

#### Rear brake calliper-pipe fitting 20 to 25

### See also

[Rear - combined](#)

---

## Front brake calliper

---

## Removal

- Remove the two retainers fastening the front brake calliper to the support as shown in the picture.

**N.B.**

**SHOULD IT BE NECESSARY TO REPLACE THE CALLIPER, FIRST LOOSEN THE FITTING CONNECTING THE PIPE TO THE BRAKE CALLIPER.**



---

## Refitting

- To fit the calliper, follow the above operations but in reverse order.

### Locking torques (N\*m)

**Screw tightening calliper to support 24 ÷ 27**

If the calliper is replaced:

**CAUTION**

**ALWAYS USE NEW COPPER WASHERS.**

**CAUTION**

**ONCE REFITTING IS FINISHED, BLEED THE SYSTEM.**

### Locking torques (N\*m)

**Brake fluid pipe-calliper fitting 20 to 25**

**See also**

[Front](#)

---

## Rear brake disc

These vehicles may feature a rear wheel with integrated hub or with a hub independent from the wheel.

---

## Removal

**REAR WHEEL WITH INTEGRATED HUB**

- 
- Remove the rear wheel.
  - Act on the disc five fixing screws shown in the picture.



### See also

[Removing the rear wheel](#)

---

## Refitting

### REAR WHEEL WITH INTEGRATED HUB

For fitting, position the disc correctly using the arrow stamped on it as reference.

**N.B.**

THE ARROW STAMPED ON THE DISC INDICATING THE RUNNING DIRECTION MUST BE FITTED TOWARDS THE OUTSIDE OF THE VEHICLE.



- 
- Tighten the screws to the prescribed torque and apply the recommended product.

### Recommended products

#### Loctite 243 Medium strength threadlock

Medium Loctite 243 threadlock

### Locking torques (N\*m)

Brake disc screws 8 to 10



## Disc Inspection

Checking the disc is important; it must be perfectly clean, with no sign of rust, oil or grease or any other dirt, and must show no signs of deep scoring.

### Characteristic

#### New rear disc thickness

4.0 mm

#### Disc thickness at wear limit (rear)

3.5 mm



- Using the specific tool, check that the axial run-out of the brake surface is within the prescribed limits.

- If this is not the case, replace the disc and repeat the test.

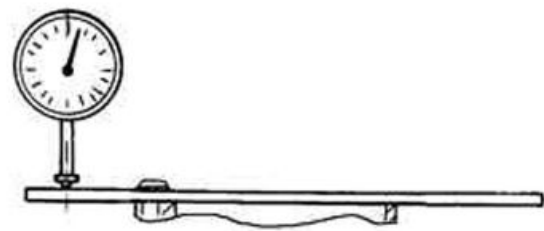

**WHEN INSTALLING, THOROUGHLY CLEAN THE DISC AND ITS SEAT ON THE HUB.**

### Characteristic

#### Max. axial run-out

0.1 mm

## Front brake disc

### Removal

Proceed as follows:

- Remove the front wheel.
- Loosen the five disc fixing screws.
- Thoroughly clean the seats on the front wheel hub and on the disc.



### See also

[Removing the front wheel](#)

### Refitting

For fitting, position the disc correctly using the arrow stamped on it as reference.

- Do up the screws to the prescribed torque and apply the recommended product

N.B.

**THE ARROW STAMPED ON THE DISC INDICATING THE RUNNING DIRECTION MUST BE FITTED TOWARDS THE OUTSIDE OF THE VEHICLE.**

### Recommended products

#### Loctite 243 Medium strength threadlock

Medium Loctite 243 threadlock

### Locking torques (N\*m)

**Brake disc screws 8 to 10**

---

## Disc Inspection

Checking the disc is important; it must be perfectly clean, with no sign of rust, oil or grease or any other dirt, and must show no signs of deep scoring.

### Characteristic

#### Thickness of a new front disc

4.0 mm

#### Disc thickness at wear limit (front)

3.5 mm



- Remove the wheel and check using the appropriate tools that the axial run-out of the brake surface is within the prescribed limits.
- If this is not the case, replace the disc and repeat the test.

**WHEN INSTALLING, THOROUGHLY CLEAN THE DISC AND ITS SEAT ON THE HUB.**

### Characteristic

#### Max. axial run-out

0.1 mm

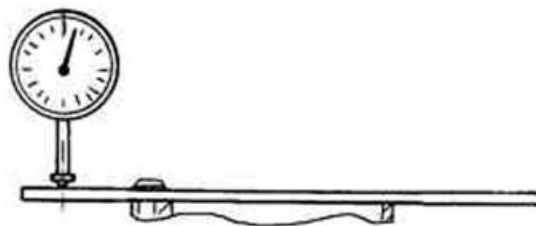

---

## Front brake pads

---

## Removal

Proceed as follows:

- Remove the front brake calliper.
- Loosen the two pins shown in the figure that lock the two pads.
- Remove the pads, being careful with the pad spring clamp.
- Check the thickness of the friction material of the pads.
- Replace the pads if the thickness is below the minimum value.
- The replacement must be made with greater residual thickness if the pad has not worn evenly. A 0.5 mm thickness difference in the residual friction material is permitted.

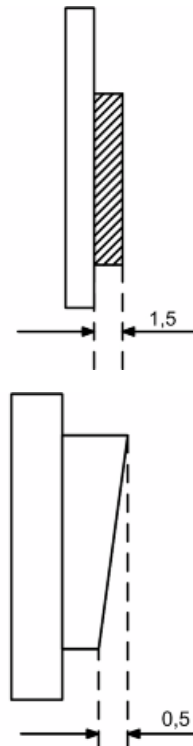

### Characteristic Minimum value

1.5 mm

### See also

[Front](#)  
brake calliper

## Refitting

To fit, proceed as follows:

- Insert the two pads in the callipers.
- Screw the two pad lock pins to the correct torque, and apply the recommended product.
- Fit the calliper on its support, tightening the two screws to the prescribed torque.

### N.B.

**IF IT IS NOT POSSIBLE TO CORRECTLY POSITION THE CALLIPER ON THE DISC DURING FITTING, GENTLY EXPAND THE PADS.**

### Recommended products

**Loctite 243 Medium strength threadlock**

Medium Loctite 243 threadlock

**Locking torques (N\*m)**

Pad fastening pin  $19.6 \div 24.5$

**Rear brake pads****Removal**

- Remove the rear brake calliper
- Loosen the two pins shown in the figure that lock the two pads; be careful with the pad spring clamp.
- Remove the brake pad and check there are no faults or warping. Replace it if such anomalies are present.
- Check the thickness of the friction material is more than 1.5 mm. If it is not, replace it
- The replacement must be made with greater residual thickness if the pad has not worn evenly. A 0.5 mm thickness difference in the residual friction material is permitted.

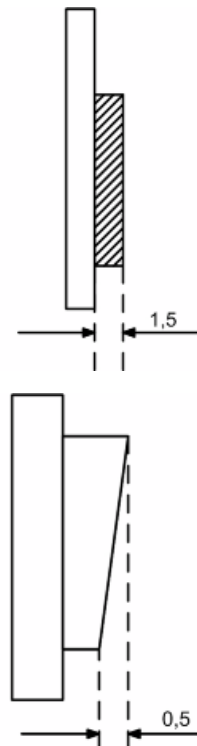
**See also**

[Removal](#)



## Refitting

To fit, proceed as follows:

- Insert the two pads in the callipers.
- Screw the two pad lock pins to the correct torque, and apply the recommended product.
- Fit the calliper on its support, tightening the two screws to the prescribed torque.

### N.B.

**IF IT IS NOT POSSIBLE TO CORRECTLY POSITION THE CALLIPER ON THE DISC DURING FITTING, GENTLY EXPAND THE PADS.**



### Recommended products

#### Loctite 243 Medium strength threadlock

Medium Loctite 243 threadlock

#### Locking torques (N\*m)

**Screw tightening calliper to support 24 to 27 Pad fastening pin 19.6 ÷ 24.5**

## Fill

### Rear - combined

- Remove the rubber cap from the bleed screw.
- Insert a rubber pipe in the bleed screw to permit the brake fluid to be recovered.
- With the brake lever, load the system and bring it up to the required pressure.
- Keeping the brake lever pulled, loosen the bleed screw to purge the air in the system. Then tighten the bleed screw
- Repeat the operation until only brake fluid comes out of the rubber pipe.
- Remove the fluid recovery pipe and refit the rubber cap over the bleed screw.
- Top up the brake fluid to the right level in the reservoir.



If necessary, bleeding can be done using a special vacuum pump

### N.B.

**DURING THE BLEEDING OPERATIONS, MAKE SURE THE BRAKE FLUID DOES NOT COME INTO CONTACT WITH THE BODYWORK SO AS NOT TO DAMAGE IT. FURTHERMORE, DURING THE BLEEDING OPERATIONS REGARDING THE BRAKE CALLIPERS, MAKE SURE THE BRAKE FLUID DOES NOT COME INTO CONTACT WITH THE DISC BRAKES AND WITH THE BRAKE PADS. FAILURE TO OBSERVE THIS PRECAUTION WILL ENDANGER THE PROPER WORKING AND EFFICIENCY OF THE BRAKING SYSTEM**

### Specific tooling

**020329Y Mity-Vac vacuum-operated pump****Locking torques (N\*m)****System bleed calliper fitting: 12 ÷ 16 Nm****Front**

- Remove the rubber cap from the bleed screw.
- Insert a rubber pipe in the bleed screw to permit the brake fluid to be recovered.
- With the brake lever, load the system and bring it up to the required pressure.
- Keeping the brake lever pulled, loosen the bleed screw to purge the air in the system. Then tighten the bleed screw



- Repeat the operation until only brake fluid comes out of the rubber pipe.
- Remove the fluid recovery pipe and refit the rubber cap over the bleed screw.
- Top up the brake fluid to the right level in the reservoir.

If necessary, bleeding can be done using a special vacuum pump

**N.B.**

**DURING THE BLEEDING OPERATIONS, MAKE SURE THE BRAKE FLUID DOES NOT COME INTO CONTACT WITH THE BODYWORK SO AS NOT TO DAMAGE IT. FURTHERMORE, DURING THE BLEEDING OPERATIONS REGARDING THE BRAKE CALLIPERS, MAKE SURE THE BRAKE FLUID DOES NOT COME INTO CONTACT WITH THE DISC BRAKES AND WITH THE BRAKE PADS. FAILURE TO OBSERVE THIS PRECAUTION WILL ENDANGER THE PROPER WORKING AND EFFICIENCY OF THE BRAKING SYSTEM**

**Specific tooling****020329Y Mity-Vac vacuum-operated pump****Locking torques (N\*m)****System bleed calliper fitting: 12 ÷ 16 Nm****Brake fluid level check**

The front and rear brake fluid reservoirs are both positioned on the handlebar. Proceed as follows:

- Rest the vehicle onto the centre stand, with the handlebar centred.
- Check the fluid level through the sight glass «A».

A certain lowering of the level is caused by wear on the brake pads.

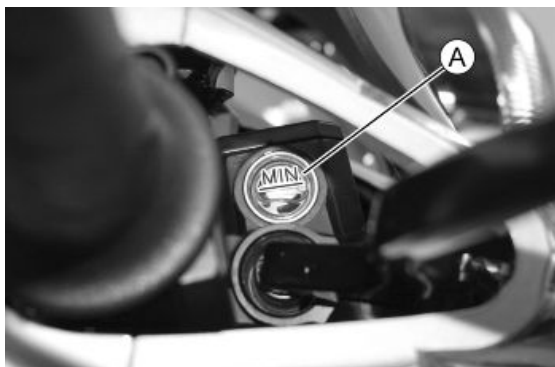

## Front brake pump

### Removal

- Remove the rear handlebar cover.
- Drain the braking system.
- Disconnect the brake fluid line from the pump, paying attention to a possible escape of remaining brake fluid.
- Remove the brake stop button from the lever.
- Undo the two U-bolt fixing screws.
- Remove the brake pump with the lever.



### Refitting

- Upon refitting, perform the operation but in reverse order.
- Tighten the hydraulic line to the prescribed torque and purge the system.
- When the operation is over, tighten the brake fluid bleed screw to the prescribed torque.

#### N.B.

**WHILE REFITTING, REPLACE THE COPPER GASKETS ON THEIR FITTINGS.**

#### WARNING

**BRAKE FLUID IS HYGROSCOPIC; THAT IS, IT ABSORBS MOISTURE FROM THE SURROUNDING AIR. IF THE LEVEL OF MOISTURE IN THE FLUID EXCEEDS A GIVEN VALUE, BRAKING WILL BE INEFFICIENT. THEREFORE, ALWAYS USE FLUID FROM SEALED CONTAINERS. UNDER NORMAL DRIVING AND CLIMATIC CONDITIONS YOU SHOULD CHANGE THIS FLUID EVERY TWO YEARS. IF BRAKES ARE USED INTENSELY AND/OR IN HARSH CONDITIONS, CHANGE THE FLUID MORE FREQUENTLY.**

#### CAUTION

**WHEN CARRYING OUT THE OPERATION, BRAKE FLUID MAY LEAK FROM BETWEEN THE BLEED SCREW AND ITS SEAT ON THE CALLIPER. CAREFULLY DRY THE CALLIPER AND DEGREASE THE DISC SHOULD THERE BE BRAKE FLUID ON IT.**

#### Locking torques (N\*m)

Oil bleed screw 12 - 16 Hydraulic line fixing screw: 16 - 20 Fixing screws for the handlebar control unit U-bolts 7 to 10

#### See also

[Front](#)

## Rear brake pump - combined

---

## Removal

- Remove the rear handlebar cover.
- Drain the braking system.
- Disconnect the brake fluid line from the pump, paying attention to a possible escape of remaining brake fluid.
- Remove the brake stop button from the lever.
- Undo the two U-bolt fixing screws.
- Remove the brake pump with the lever.

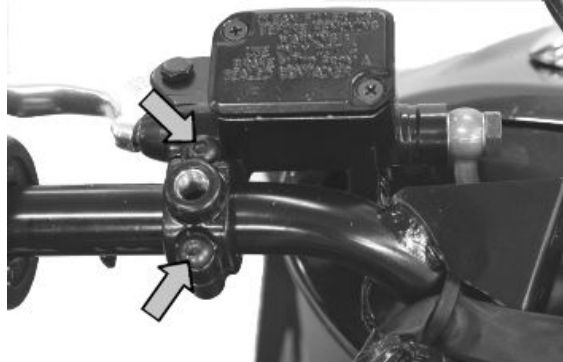

---

## Refitting

- Upon refitting, perform the operation but in reverse order.
- Tighten the hydraulic line to the prescribed torque and purge the system.
- When the operation is over, tighten the brake fluid bleed screw to the prescribed torque.

**N.B.**

**WHILE REFITTING, REPLACE THE COPPER GASKETS ON THEIR FITTINGS.**

**WARNING**

**BRAKE FLUID IS HYGROSCOPIC; THAT IS, IT ABSORBS MOISTURE FROM THE SURROUNDING AIR. IF THE LEVEL OF MOISTURE IN THE FLUID EXCEEDS A GIVEN VALUE, BRAKING WILL BE INEFFICIENT. THEREFORE, ALWAYS USE FLUID FROM SEALED CONTAINERS. UNDER NORMAL DRIVING AND CLIMATIC CONDITIONS YOU SHOULD CHANGE THIS FLUID EVERY TWO YEARS. IF BRAKES ARE USED INTENSELY AND/OR IN HARSH CONDITIONS, CHANGE THE FLUID MORE FREQUENTLY.**

**CAUTION**

**WHEN CARRYING OUT THE OPERATION, BRAKE FLUID MAY LEAK FROM BETWEEN THE BLEED SCREW AND ITS SEAT ON THE CALLIPER. CAREFULLY DRY THE CALLIPER AND DEGREASE THE DISC SHOULD THERE BE BRAKE FLUID ON IT.**

### Locking torques (N\*m)

Oil bleed screw 12 - 16 Hydraulic line fixing screw: 16 - 20 Fixing screws for the handlebar control unit U-bolts 7 to 10

**See also**

[Rear - combined](#)

---

# INDEX OF TOPICS

COOLING SYSTEM

COOL SYS

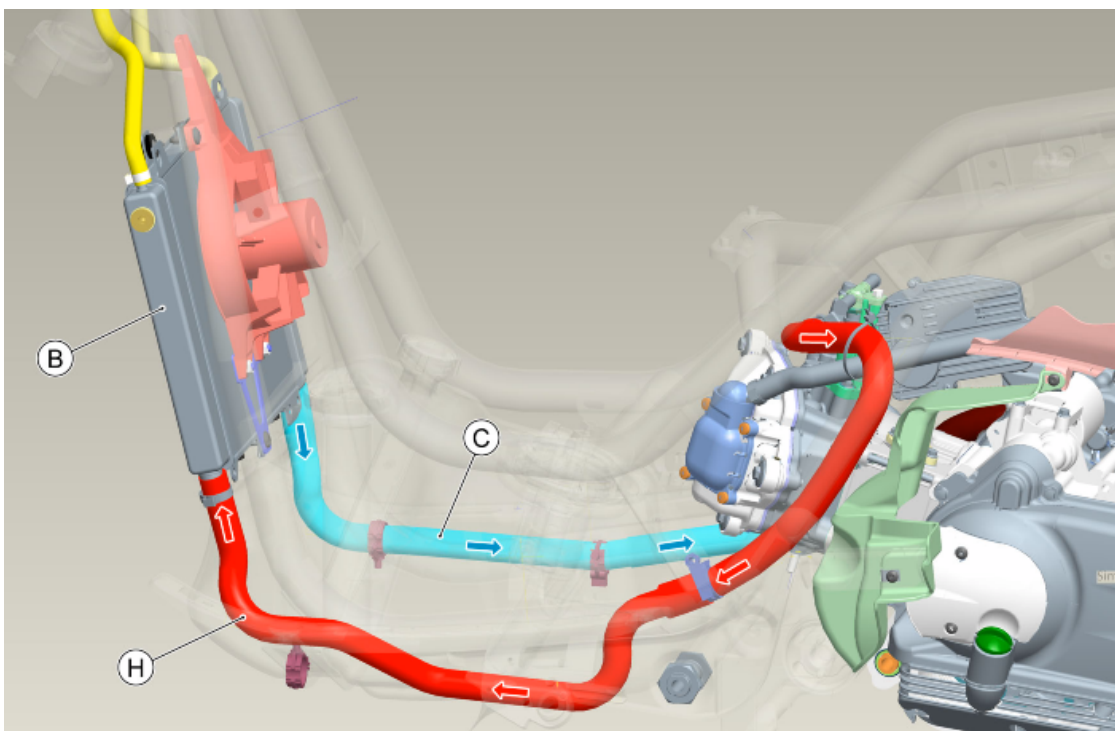
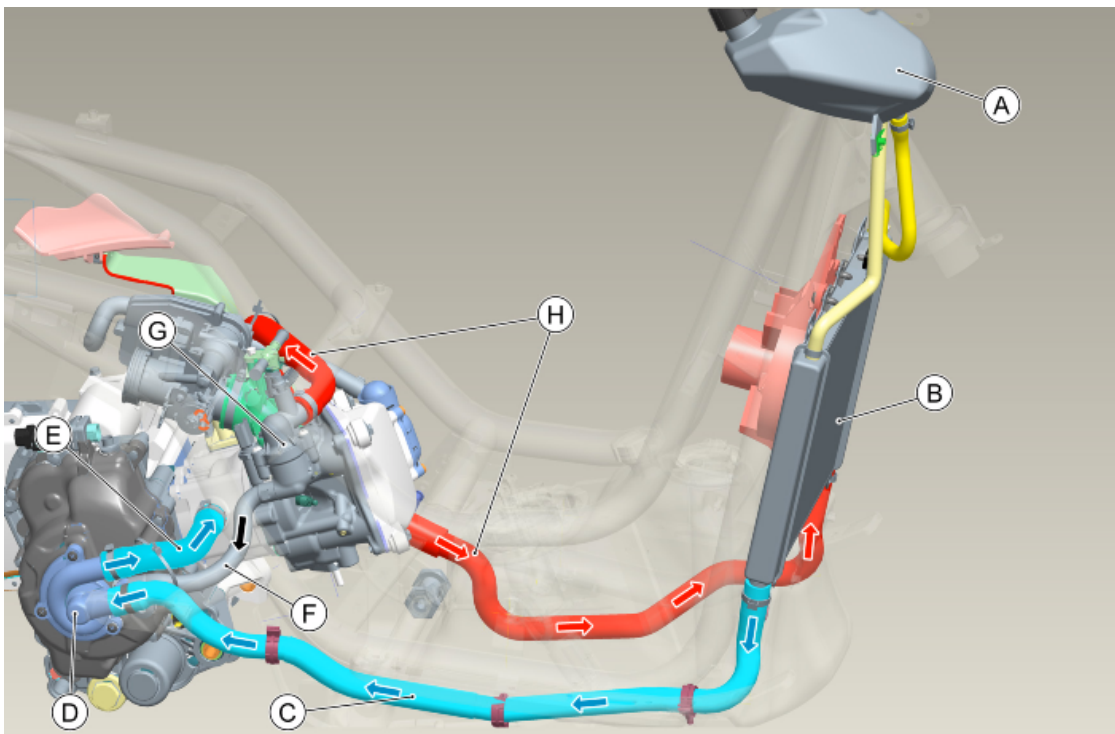
**Circuit diagram****KEY**

**A** = Expansion tank

**B** = Radiator

**C** = Radiator intake pipe

**D** = Water pump

**E** = Delivery pipe to cylinder

**F** = By-Pass pipe

**G** = Thermostat

**H** = Radiator delivery pipe

**TECHNICAL SPECIFICATIONS**

Specification	Desc./Quantity
Cooling system capacity:	~ 2 l
Recommended fluid	AGIP PERMANENT SPEZIAL (ready for use)
Sealing pressure	Cap calibrated at 0.9 bar

**THERMOSTAT**

Specification	Desc./Quantity
Type	Wax-type, with deviator
Starts opening at	85 ± 2°C

**ELECTRIC VENTILATION**

Specification	Desc./Quantity
Electric ventilation starts at	100° C
Electric ventilation stops at	90° C

**WATER PUMP**

Specification	Desc./Quantity
Type	Centrifugal
Control	Electric, commanded by the control unit

**RADIATOR**

Specification	Desc./Quantity
Type	Aluminium, with horizontal circulation

**EXPANSION TANK**

Specification	Desc./Quantity
Calibration	Automatic bleeding, in parallel with the radiator

**Electric fan check**

- Check and, if necessary, restore the correct battery voltage.

**Characteristic**

**Battery voltage**

12V

- Check that the electric ventilation relay is working properly.

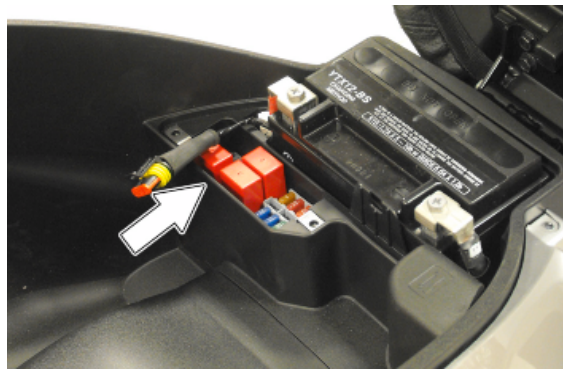

#### WARNING

**TO INDICATE THE SOLENOID OF THE DESIRED FUNCTION, REFER TO THE PIN-CABLE COLOUR RELATIONSHIP WITH THE ATTACHED ELECTRIC SYSTEM DIAGRAM.**

- If the relay is not working, replace it.
- If the relay is working, remove it and jump the red - red black (85 - 86) wires. The electric ventilation starts if the ignition switch is set to «ON» and all components are working.

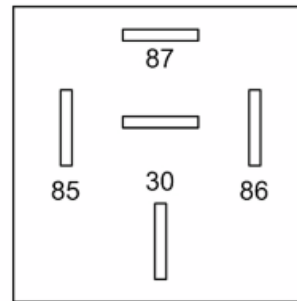

- In order to check the coolant temperature sensor, see the «Injection» chapter.

#### See also

[Remote controls check](#)

## System bleed

- Start up the engine until the operating temperature is reached.
- Remove the rubber hood over the bleed valve
- Obtain a rubber tube that is of the right length to connect the valve to the expansion tank
- Place one end of the pipe on the bleed valve and the other in the expansion tank
- Loosen the screw by **two** turns until the communication hole is revealed with the head as shown in the picture
- Wait until only coolant comes out of the rubber pipe so as to eliminate any air bubbles inside the circuit.





- Tighten the bleed valve respecting the maximum torque.
- Bring the coolant up to the correct level inside the expansion tank

**Locking torques (N\*m)****Bleed screw 3****Thermostat****Removal**

- Remove the helmet compartment inspection cover.
- Place a + 2.0 l container under the vehicle to collect the coolant.
- Undo the two screws indicated, lift the cover and remove the thermostat.

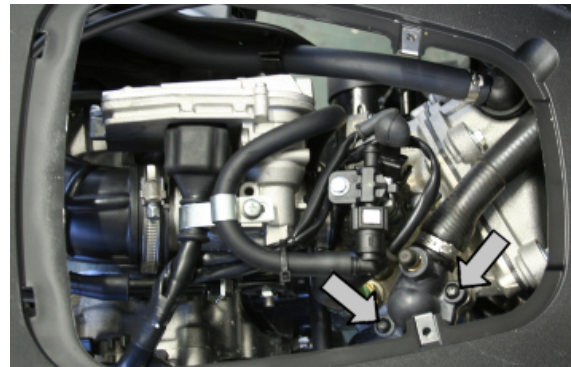

## Check

1) Visually inspect that the thermostat is not damaged.

2) Fill a metal container with approx. 1 litre of water.

Immerse the thermostat, and keep it in the centre of the container.

Immerse the multimeter temperature probe, and keep it close to the thermostat.

Heat up the container using the thermal gun.

Check the temperature at which the thermostat starts to open:

Heat up until the thermostat is completely open.

3) Replace the thermostat if it is not working properly.



### CAUTION

TO EXECUTE THE TEST CORRECTLY, MAKE SURE NEITHER THE THERMOSTAT NOR THE THERMOMETER TOUCHES THE CONTAINER.

### Specific tooling

020331Y Digital multimeter

020151Y Air heater

### THERMOSTAT

Specification	Desc./Quantity
Type	Wax-type, with deviator
Starts opening at	85±2°C

## Refitting

- Follow the removal steps but in reverse order; be careful to tighten screws to the prescribed torque.

### Locking torques (N\*m)

#### Thermostat cover screws 3 to 4

- Once the cooling circuit is restored, refill using the recommended product and purge the circuit as expressly indicated in the «Cooling System» chapter.

## INDEX OF TOPICS

**CHASSIS**

**CHAS**

This section è is dedicated to the operations that can be carried out on the vehicle's bodywork.

## Seat

Undo the two screws indicated in the figure and retrieve the two bushings.

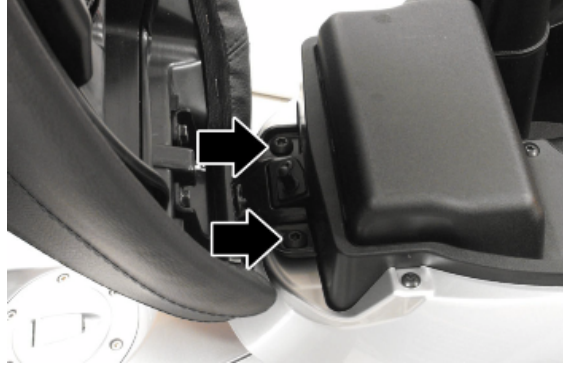

## Rear rack

To remove the luggage rack:

- Lift the saddle;
- Unscrew the indicated screw and remove the plastic cover;

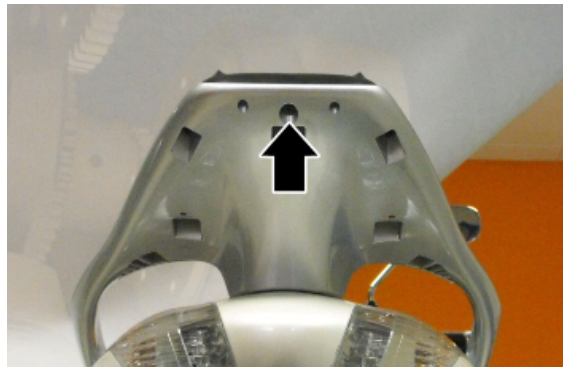

- Unscrew the two indicated screws and retrieve the washers;

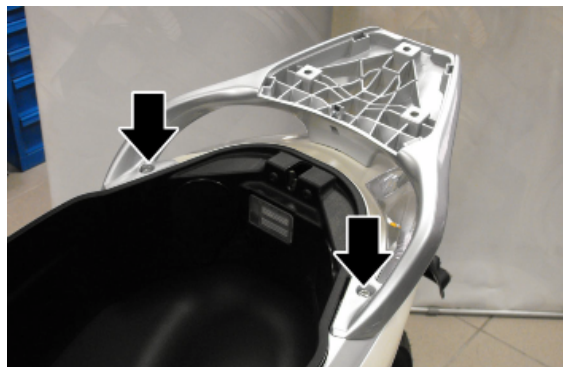

- Unscrew the centre screw and retrieve the washers;
- Remove the luggage rack.

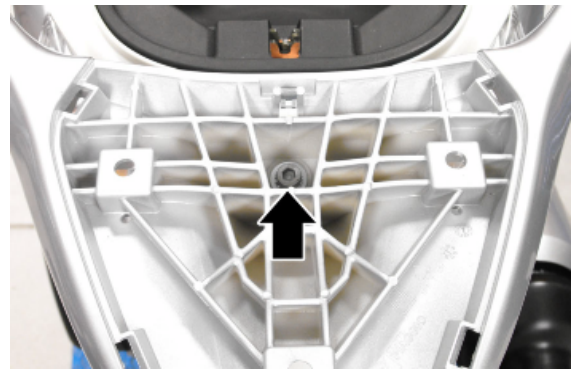

### Rear handlebar cover

To remove the handlebar cover, proceed as follows:

- Remove the mirrors unscrewing them from their seats
- Unscrew the two screws «A» and remove the pressure covering.
- Unscrew the two screws «B» and, working on both sides of the vehicle, unscrew the screw «C».
- Using a flat-headed screwdriver, detach the fastener tab as shown in the figure, accessing the tab via the indicated slit
- Insert the screwdriver between the two covers, as indicated in the figure, and detach the upper fastener tab
- Move the rear handlebar cover aside, disconnect all the electrical connectors and remove the handlebar cover.

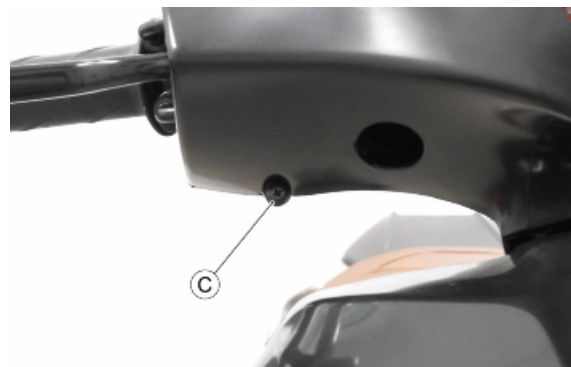

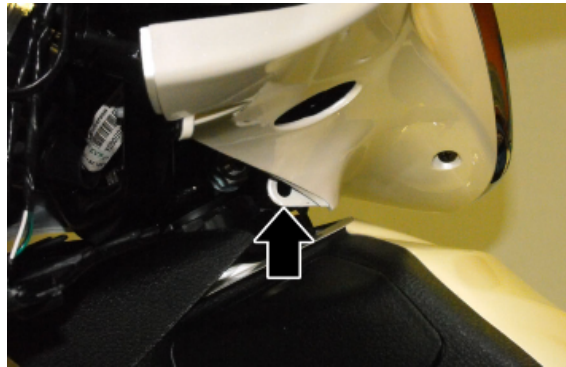

---

## Instrument panel

- Remove the rear handlebar cover;
- Undo the four screws indicated to remove the assembly.

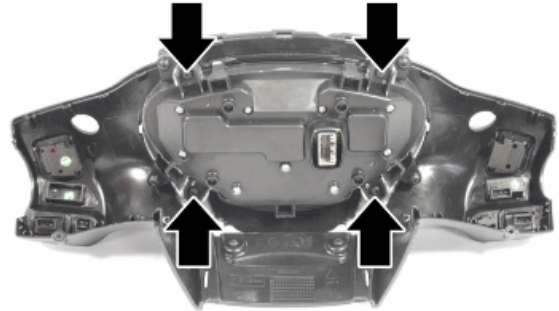

---

## Front handlebar cover

To remove the handlebar cover, proceed as follows:

- Remove the rear handlebar cover.
- Unscrew the two screws «D» and remove the front handlebar cover, disconnecting the front headlight connector

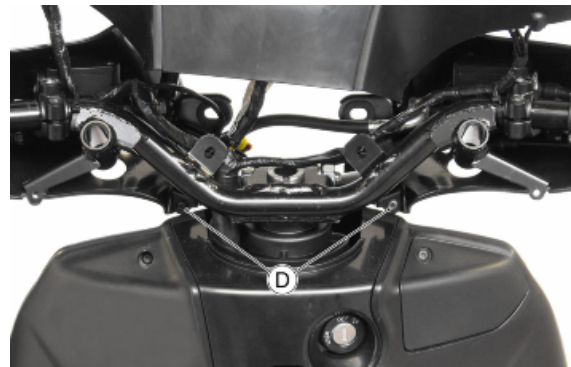

### See also

[Rear handlebar cover](#)

---

## Headlight assy.

---

## Frame central cover

- Remove the side fairings;
- Remove the footrests;
- Open the glove compartment and undo the four screws indicated on both sides of the vehicle;



- Undo the indicated screw on both sides of the vehicle;
- Release the fastener clips and remove the cover;

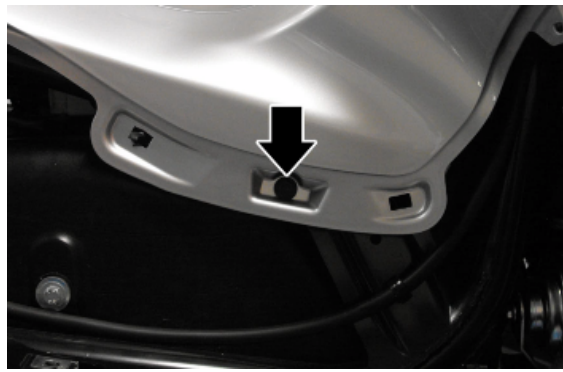

- Undo the two screws indicated on both sides of the vehicle;
- Lift the rear of the cover to access the clamp fastening the bellow to the fuel tank, and detach the clamp with a screwdriver;
- Remove the central frame cover.

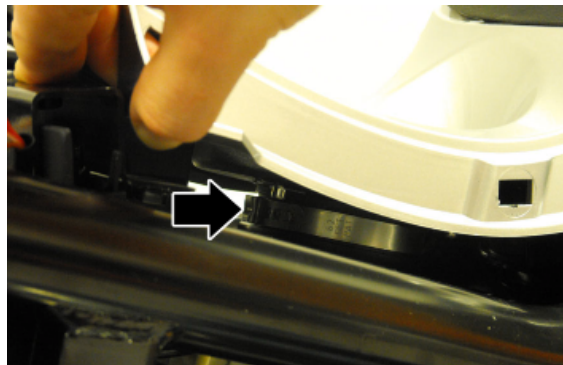
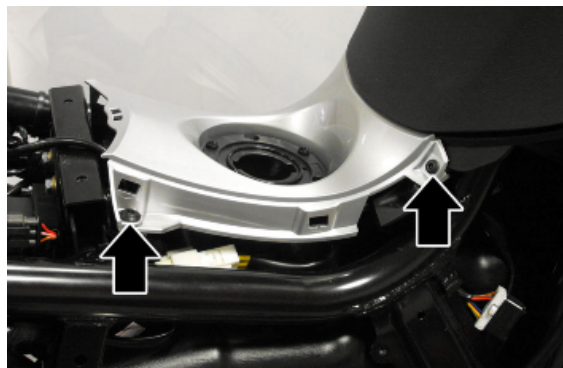

## Legshield

- To remove the front shield, proceed as follows:
- Remove the frame central cover;
  - Undo the indicated screw on both sides of the vehicle;





- 
- Remove the Piaggio clip-on badge and undo the screw underneath;



- 
- Undo the two screws indicated and remove the expansion tank cover.
  - Undo the indicated screw;

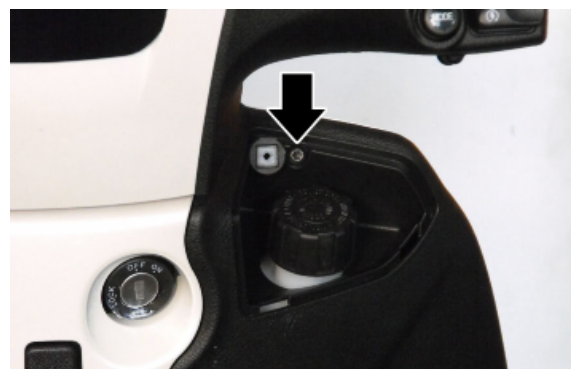

- Open the glove compartment and undo the indicated screw from both sides of the vehicle.
- Move the shield aside, releasing the fastener clips, and disconnect the connectors and lamp holders from the headlights;
- Unscrew the three screws indicated to remove the two headlights from the shield.

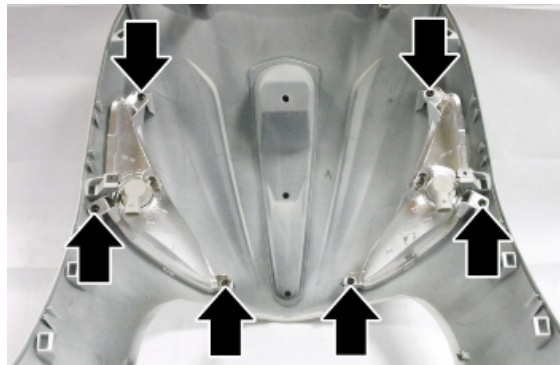

### See also

[Frame central cover](#)

## Knee-guard

To remove the leg shield back plate, proceed as follows:

- Remove the legshield;
- Unscrew the expansion tank cap;
- Unscrew the two screws indicated and release the two retainer tabs to remove the indicated cover;

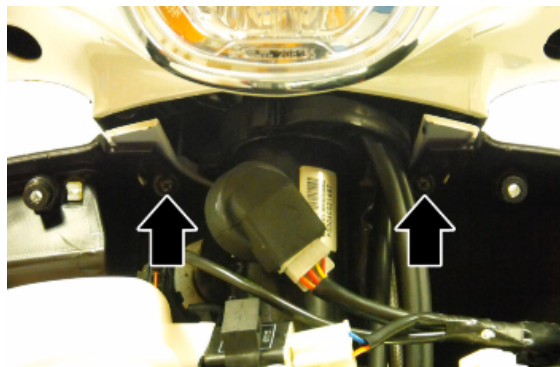

- Unscrew the screw located above the emergency saddle release lever and the screw near the ignition key;



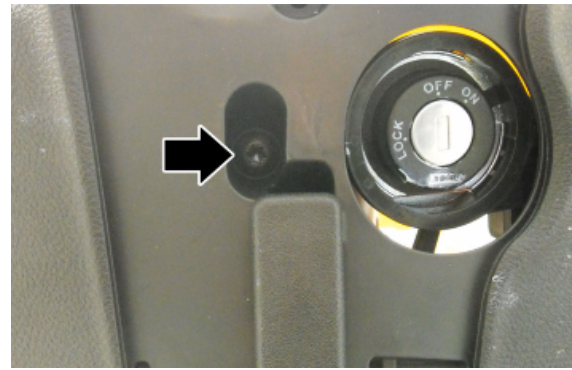

- Undo the two screws indicated in the figure;



- Disconnect the LV socket connector and the coolant return pipe from the relative seat on the leg shield back plate;
- Unscrew the screw fastening the expansion tank to the leg shield back plate, taking care not to spill any coolant;

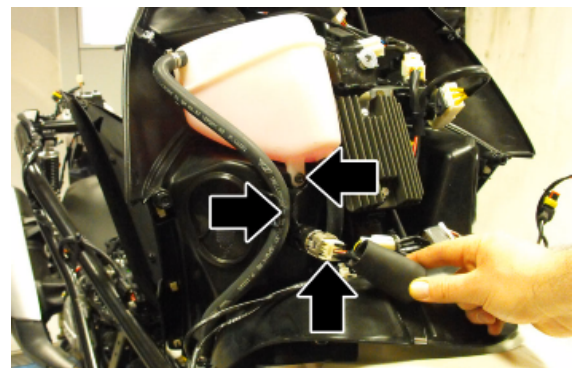

- Detach the emergency saddle release linkage from the lever as indicated in the figure;
- Remove the leg shield back plate.



### See also

[Legshield](#)

---

## Removing the ignition key-switch when on \*off\*

---

Proceed as follows to remove the lock when in the «OFF» position:

- Remove the leg shield back plate;
- Disconnect the connector as indicated in the figure and remove the immobilizer antenna, detaching from the lock body;



- Release the indicated clip and remove the ignition key;

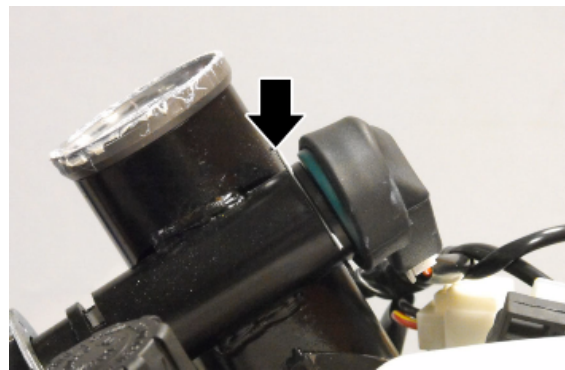

- Press the lock body and remove the cylinder clip as indicated;
- Release the lock body and remove the cylinder.

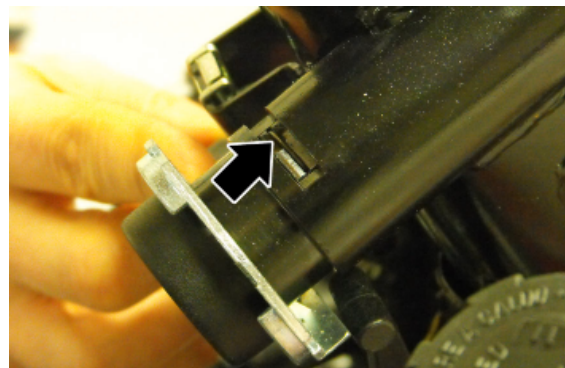

### See also

[Knee-guard](#)

---

---

## Removing the ignition key-switch when on \*lock\*

---

In position "Lock", it is not possible to access the cylinder retaining spring. The spring must then be removed as shown in the figure, allowing the lock spring to be pressed out.

**N.B.**

**TO REFIT THIS ITEM, THE VEHICLE STEERING LOCK MUST BE RELEASED WITH THE LOCK BODY (INTERNAL AND EXTERNAL PART) IN POSITION "OFF". PROCEED AS DESCRIBED IN THE PREVIOUS PARAGRAPH.**

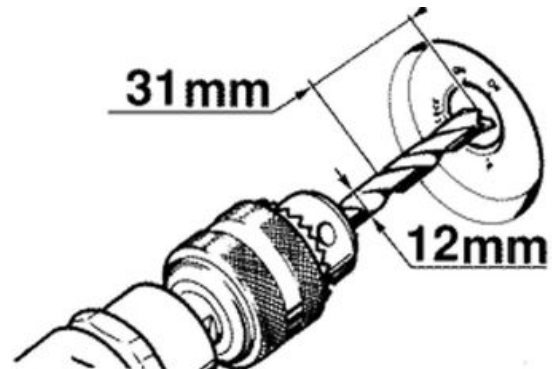

### See also

[Removing the ignition key-switch when on \\*off\\*](#)

---

## Front wheel housing

---

To remove the front wheel housing, proceed as follows:

- Remove the leg shield back plate;
- Remove the handlebar covers;
- Remove the fork;
- Release the indicated clamps from the wheel housing;
- Undo the three screws indicated and remove the wheel housing.

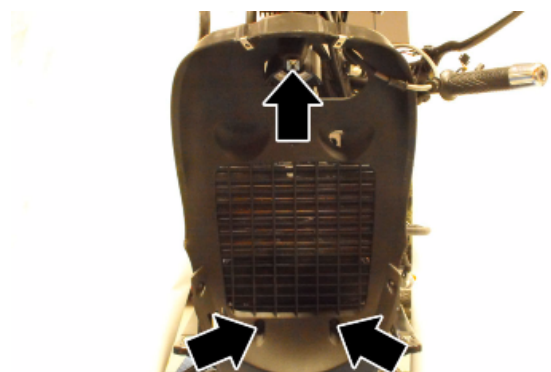
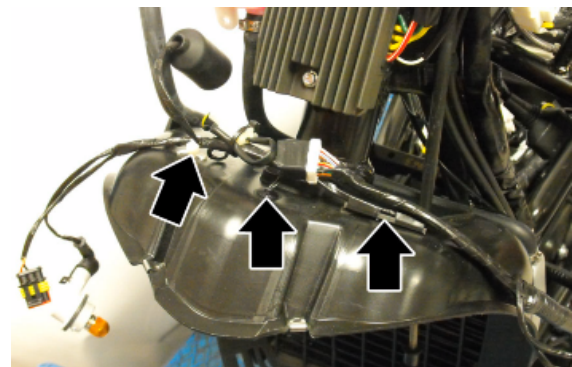

### See also

[Knee-guard](#)

---

## Taillight assy.

To remove the rear light assembly, proceed as follows:

- Remove the side fairings;
- Undo the three screws indicated in the figure.

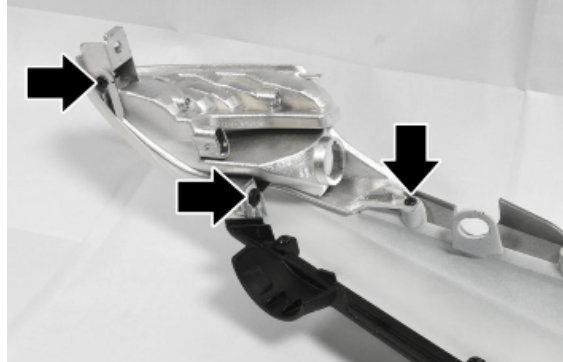

### See also

[Side fairings](#)

## Footrest

The following procedure is applicable for both sides of the vehicle:

- Unscrew the three screws indicated and remove the passenger footrest;

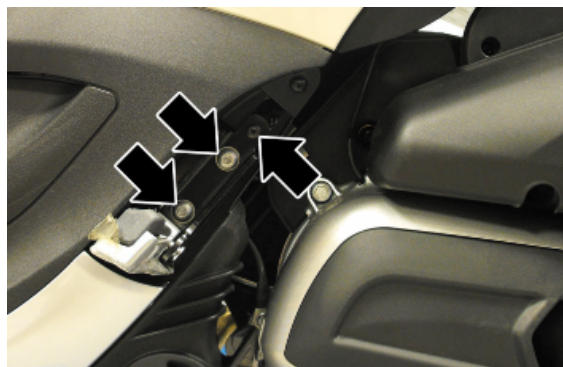

- Unscrew the screw fastening the footrest to the side fairing;



- Unscrew the screws fastening the footrest to the front wheel housing;

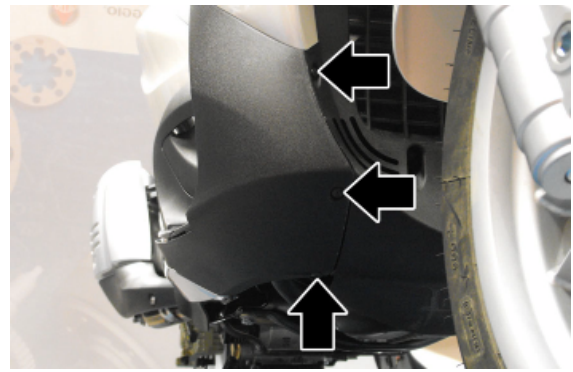

- Use a flat headed screwdriver to remove the plugs and the mat as indicated in the figure;
- Unscrew the three screws indicated and remove the passenger footrest, releasing the fastener clips.

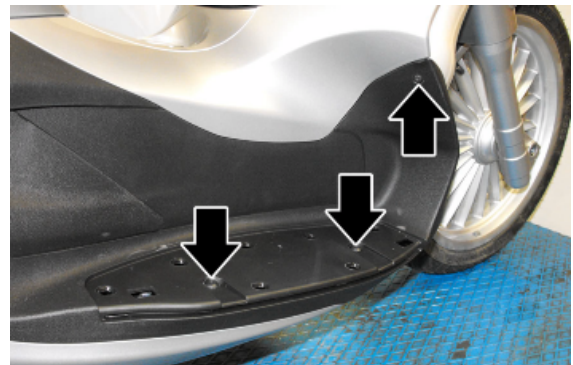
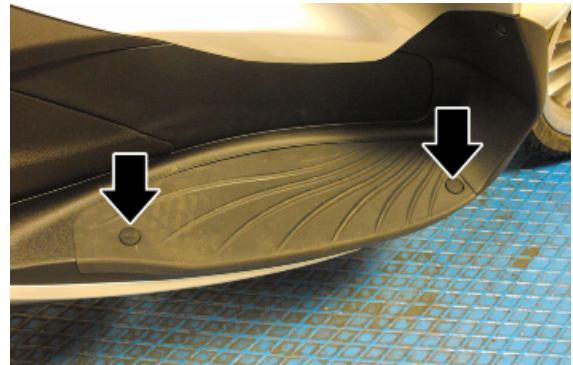

## Side fairings

Proceed as follows to remove the side fairings:

- Remove the saddle;
- Remove the rear luggage rack;
- Unscrew the two screws indicated and remove the centre rear cover;



- 
- Unscrew the screw fastening the taillight;

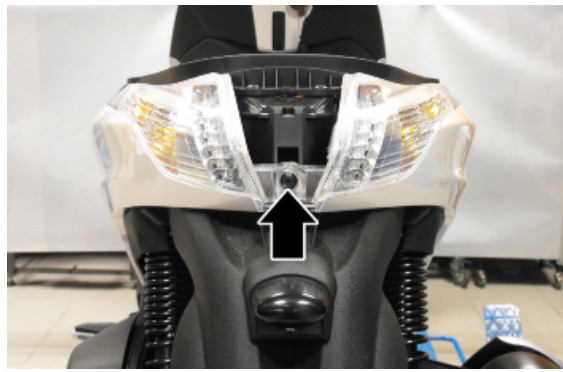

- 
- Unscrew the screw indicated in the figure;

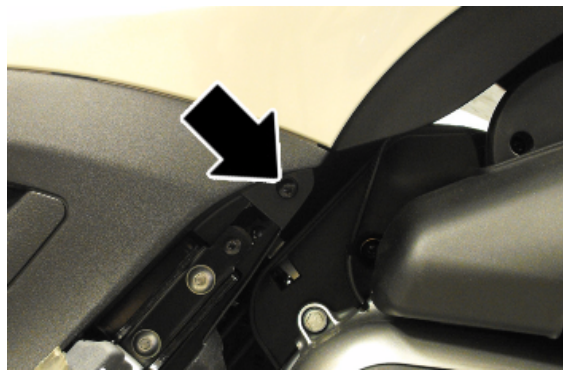

- 
- Unscrew the three screws indicated and remove the side fairing, complete with taillights, releasing the indicated fastener clip. Disconnect the two connectors from the taillight.

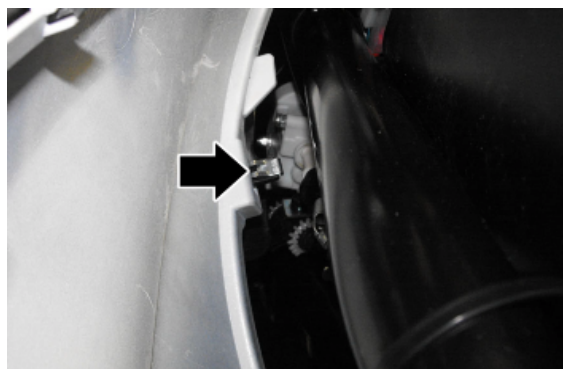
**See also**[Seat](#)



---

## License plate holder

---

To remove the license plate mounting, proceed as follows:

- Remove the helmet compartment;
- Undo the three screws indicated;
- Unscrew the indicated screw and release the license plate light lamp holder.

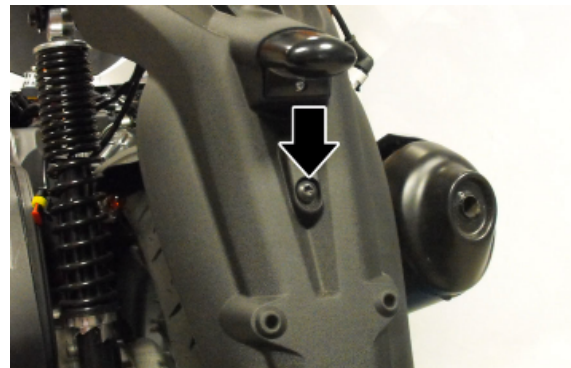
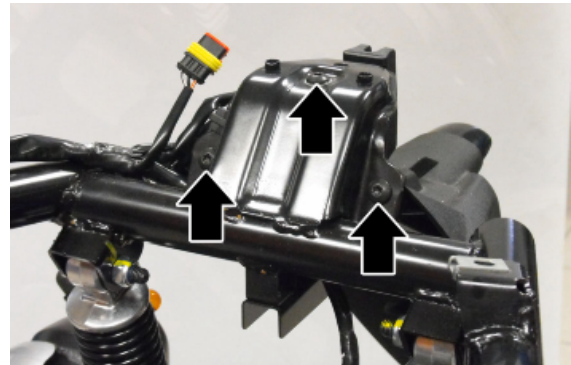

### See also

[Helmet bay](#)

---

## Helmet bay

---

To remove the helmet compartment, proceed as follows:

- Remove the side fairings;
- Pull out the battery cables and unscrew the screw «A» and «B»;



- 
- Unscrew the two screws indicated to release the lock and detach the lock linkages from the indicated retainer in the compartment itself;

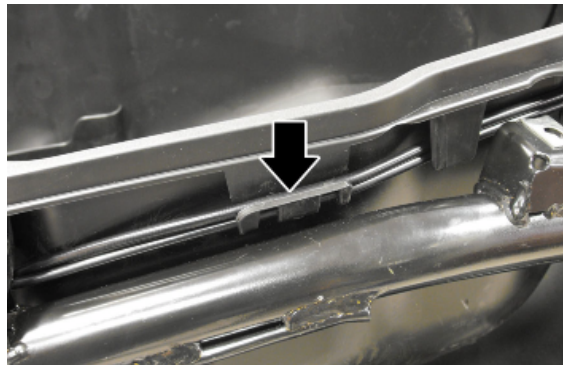
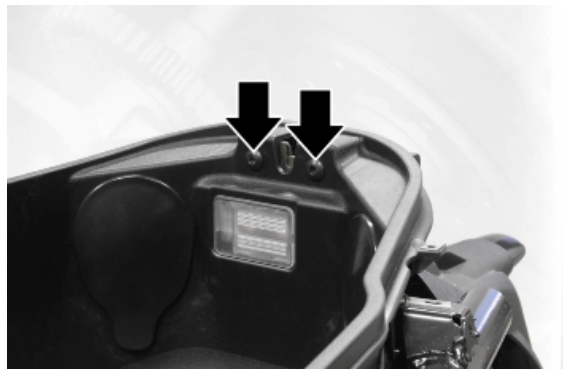

- 
- Unscrew the two rear screws;

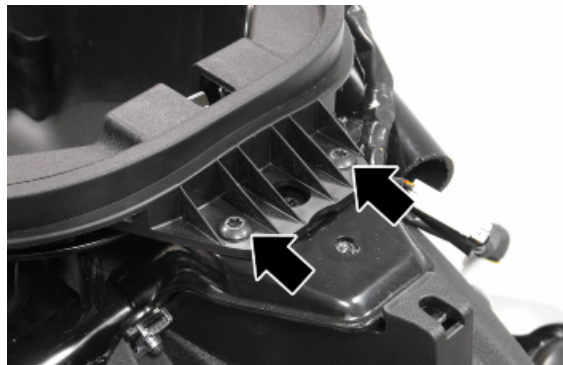

- 
- Undo the indicated screw on both sides of the vehicle;



- Unscrew the two screws indicated;

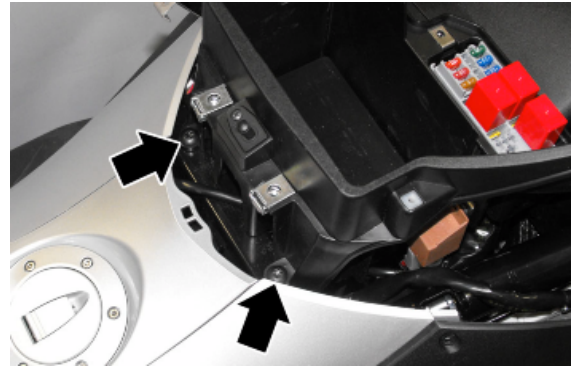

- Lift the rear of the helmet compartment, disconnect the helmet compartment light connector and release the saddle release linkage retainer clip;
- Remove the helmet compartment, detaching from the fuse terminal block.

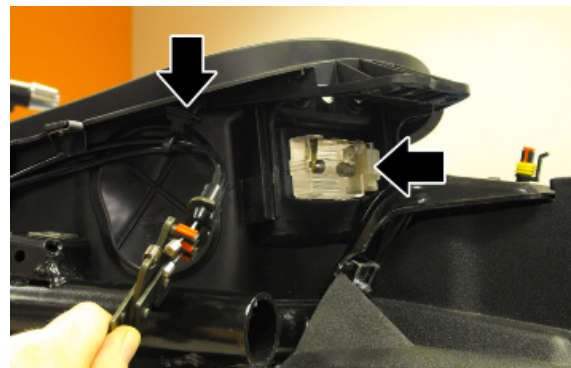

### See also

[Side fairings](#)

## Front mudguard

To remove the front mudguard, proceed as follows:

- On both sides of the vehicle, unscrew the indicated screws and remove the stanchion guard;

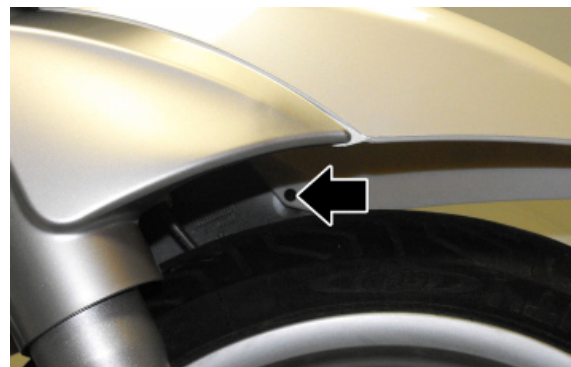

- Unscrew the three bolts indicated inside the mudguard;
- Detach the brake hose from the two indicated seats and remove the mudguard, pulling from the front.

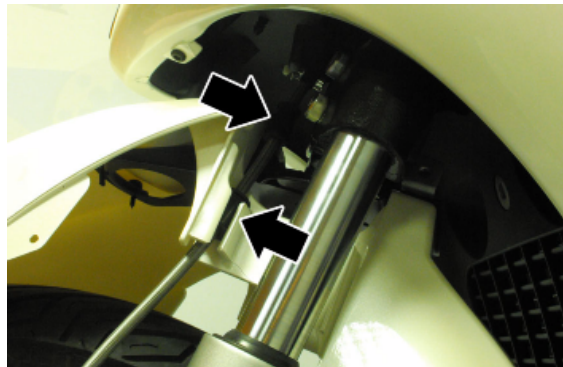
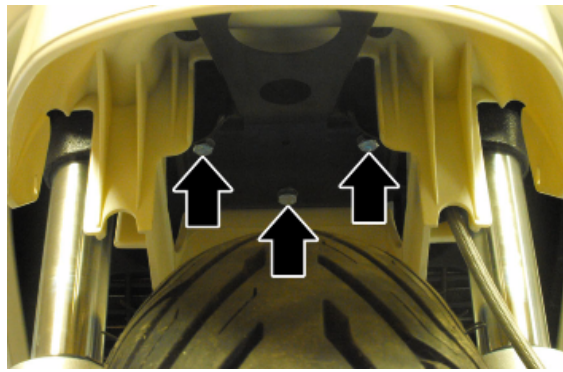

## Radiator fan

To remove the radiator electric fan, proceed as follows:

- Remove the front wheel housing.
- Obtain a suitably sized container and drain the cooling system by removing the indicated clamp. Open the expansion tank cap to facilitate draining;

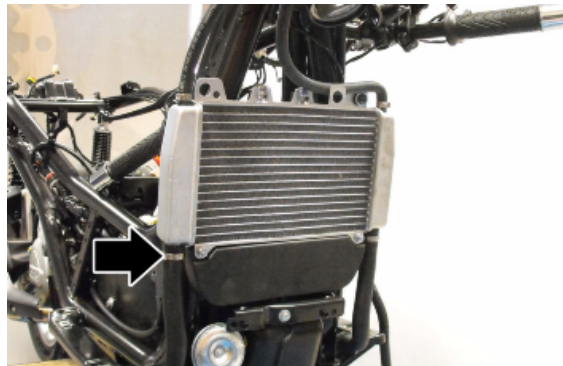

- Detach the radiator from the circuit pipes;
- Unscrew the indicated screw and remove the radiator, lifting out of its seat.

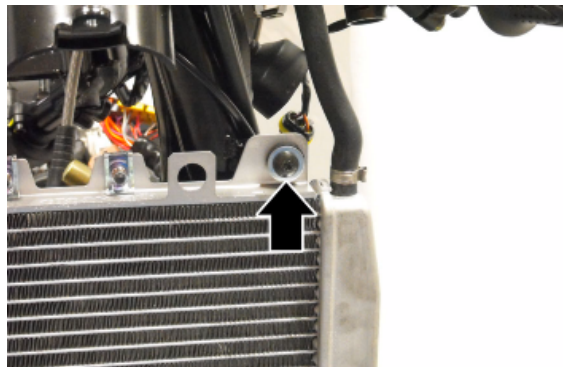

### See also

[Front wheel housing](#)

## Expansion tank

To remove the expansion tank, proceed as follows:

- Remove the leg shield back plate;
- Drain the cooling system by removing the indicated clamp;
- Unscrew the indicated screw and remove the expansion tank.

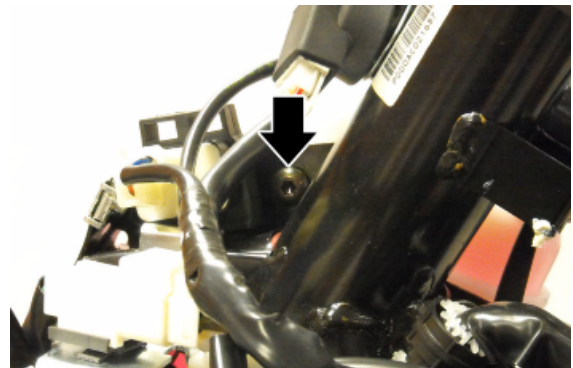
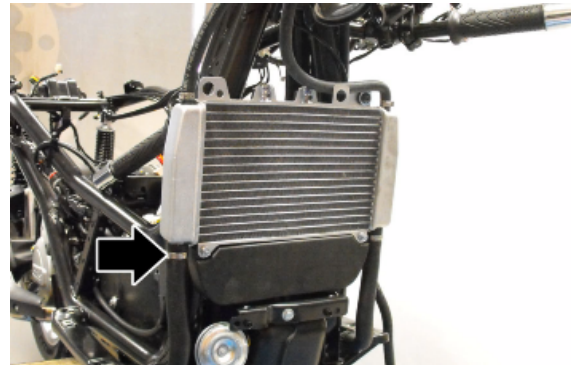

### See also

[Knee-guard](#)

## Battery

To access the battery, proceed as follows:

- Position the vehicle on centre stand
- Open the saddle, following the previously described procedure
- Unscrew the three screws «A» and remove the cover «B»

The battery is the electrical device that requires the most frequent attention and the most thorough maintenance.

The main points of maintenance to be observed are as follows:

### WARNING



**DO NOT DISCONNECT THE BATTERY CABLES WITH THE ENGINE RUNNING, THIS CAN CAUSE IRREPARABLE DAMAGE TO THE VEHICLE'S ELECTRONIC CONTROL UNIT.**

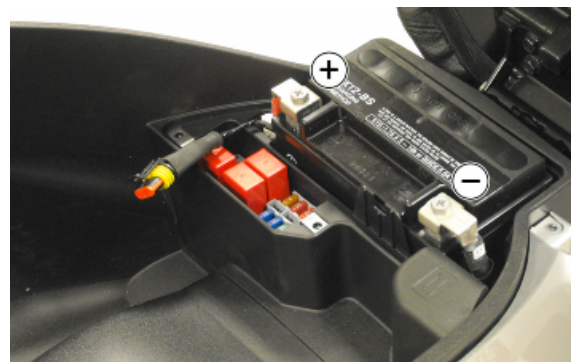
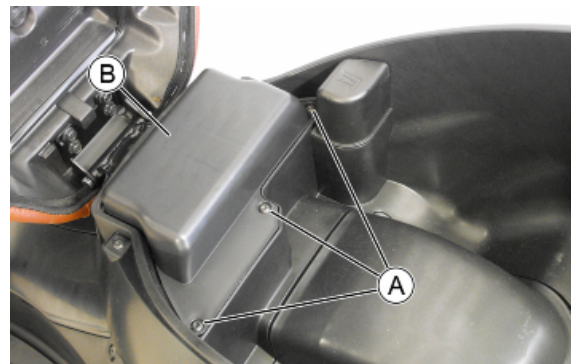

**WARNING**



USED BATTERIES ARE HARMFUL FOR THE ENVIRONMENT. COLLECTION AND DISPOSAL SHOULD BE CARRIED OUT IN COMPLIANCE WITH REGULATIONS IN FORCE.

**Characteristic**

**Battery**

SEALED 12V/10Ah

---

# INDEX OF TOPICS

**P**RE-DELIVERY

**PRE DE**

Carry out the listed tests before delivering the vehicle.

Warning - Handle fuel with care.

---

## Aesthetic inspection

### Appearance check:

- Paintwork
  - Fitting of plastics
  - Scratches
  - Dirt
- 

## Tightening torques inspection

- Visually check that there is a yellow mark on the following clamps:

### FRONT SUSPENSION

- Front wheel pin nut.
- Screws fixing wheel pin on right fork leg.

### FRONT BRAKE

- Screws fixing front brake callipers to fork.
- Brake pipes / front brake calliper coupling.

### REAR SUSPENSION

- Rear wheel tightening screws.
- Lower shock absorber retainer.
- Nuts fixing muffler supporting arm - engine.
- Screws fixing muffler to supporting arm.
- Rear wheel pin nut.

### REAR BRAKE

- Screws fixing rear brake calliper to supporting plate.
  - Brake pipe to rear brake calliper coupling.
  - Screws fixing supporting plate to engine.
- 

## Electrical system

- Main switch
  - Lights: high-beam lights, low-beam lights, taillights (front and rear) and relevant warning lights
  - Headlight adjustment according to the regulations currently in force
  - Front and rear stop light buttons and relative light • Turn indicators and relative telltales
  - Instrument lighting
  - instruments: fuel and temperature indicator
-



- Instrument panel lights
- Horn
- Electrical start up
- Engine stopping with emergency stop switch
- electric saddle opening button

**CAUTION**

**TO ENSURE MAXIMUM PERFORMANCE, THE BATTERY MUST BE CHARGED BEFORE USE. INADEQUATE CHARGING OF THE BATTERY WITH A LOW LEVEL OF ELECTROLYTE BEFORE IT IS FIRST USED SHORTENS THE LIFE OF THE BATTERY.**

**CAUTION**

**WHEN INSTALLING THE BATTERY, ATTACH THE POSITIVE LEAD FIRST AND THEN THE NEGATIVE ONE.**

**WARNING**

**BATTERY ELECTROLYTE IS TOXIC AND IT MAY CAUSE SERIOUS BURNS. IT CONTAINS SULPHURIC ACID. AVOID CONTACT WITH YOUR EYES, SKIN AND CLOTHING.**

**IN CASE OF CONTACT WITH YOUR EYES OR SKIN, RINSE WITH ABUNDANT WATER FOR ABOUT 15 MINUTES AND SEEK IMMEDIATE MEDICAL ATTENTION.**

**IF IT ACCIDENTALLY SWALLOWED, IMMEDIATELY DRINK LARGE QUANTITIES OF WATER OR VEGETABLE OIL. SEEK IMMEDIATE MEDICAL ATTENTION.**

**BATTERIES PRODUCE EXPLOSIVE GASES; KEEP THEM AWAY FROM NAKED FLAMES, SPARKS AND CIGARETTES. IF THE BATTERY IS CHARGED IN A CLOSED PLACE, TAKE CARE TO ENSURE ADEQUATE VENTILATION. ALWAYS PROTECT YOUR EYES WHEN WORKING CLOSE TO BATTERIES.**

**KEEP OUT OF THE REACH OF CHILDREN**

**CAUTION**

**NEVER USE FUSES WITH A CAPACITY HIGHER THAN THAT RECOMMENDED. USING A FUSE OF UNSUITABLE RATING MAY SERIOUSLY DAMAGE THE VEHICLE OR EVEN CAUSE A FIRE.**

---

## Levels check

**Level check:**

- Hydraulic brake system liquid level.
  - Rear hub oil level
  - Engine coolant level
  - Engine oil level
- 

## Road test

**Test ride**

- Cold start
  - Instrument operations
  - Response to the throttle control
  - Stability on acceleration and braking
  - Rear and front brake efficiency
  - Rear and front suspension efficiency
-

- Abnormal noise

---

## Static test

### Static control after the test ride:

- Hot engine restart
- Minimum seal (turning the handlebar)
- Uniform steering rotation
- Possible losses
- electric radiator fan operation

#### CAUTION

**CHECK AND ADJUST TYRE PRESSURE WITH TYRES AT AMBIENT TEMPERATURE.**

#### CAUTION

**NEVER EXCEED THE RECOMMENDED INFLATION PRESSURES OR TYRES MAY BURST.**

---

## Functional inspection

Functional Checks:

- Hydraulic braking system: lever travel
  - Clutch: proper functioning check
  - Engine: proper general functioning and no abnormal noise check
  - Other: papers check, frame and engine number check, tools and equipment, licence plate fitting, lock check, tyre pressure check, rear-view mirror and any accessory fitting
- 

## Instruments start-up

Use the switch "MODE" to "ODO" mode

Hold the switch "MODE" for more than 3 seconds, the hours will be displayed. Hours will increase each time the "MODE" button is pressed.

Once the hour is adjusted, hold the switch "MODE" more than 3 seconds to display the minutes. Minutes will increase each time the "MODE" button is pressed.

If no key is pressed for 3 seconds, the system will leave the clock adjustment mode.

#### WARNING

FOR SAFETY REASONS, CLOCK ADJUSTMENT IS POSSIBLE EXCLUSIVELY WITH VEHICLE SPEED EQUAL TO 0 Km/h.



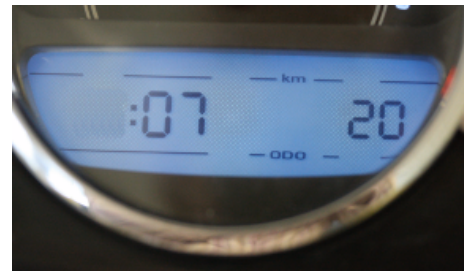

TRIP COUNTER PARTIAL RESET

In the partial trip counter function, press and hold the MODE button for longer than 3 seconds and it will reset.

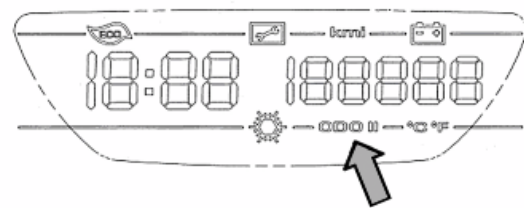

SELECT MILES - KM

When using the function measuring the voltage of the battery, holding down the MODE button for longer than 10 seconds will switch between reading in kilometres or miles for the odometer.

For the first 5 seconds, the instrument panel will not give any signal; for the next 5 seconds the unit of measurement (km or miles) currently in use will be displayed blinking at frequency of 1 Hz. If the button is released before 10 seconds, the unit of measurement will not be changed.

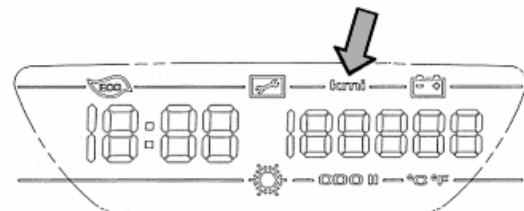

# INDEX OF TOPICS

TIME

TIME

This section is dedicated to the time necessary to carry out repairs.

For each operation, the description, code and time envisages are specified.

**Engine**

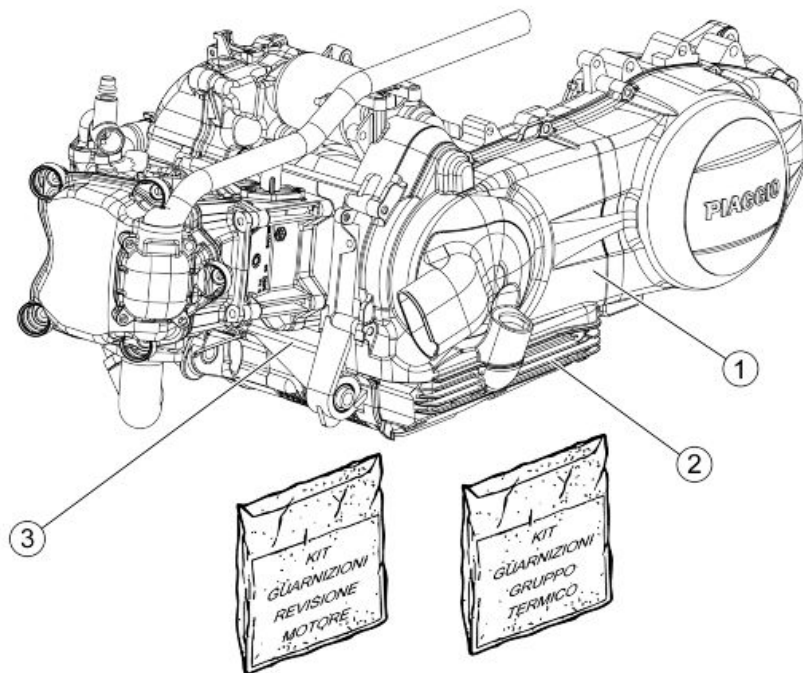

**ENGINE**

	<b>Code</b>	<b>Action</b>	<b>Duration</b>
1	001001	Engine from chassis - Removal and refit.	
2	003064	Engine oil - change	
3	001127	Engine - Complete service	

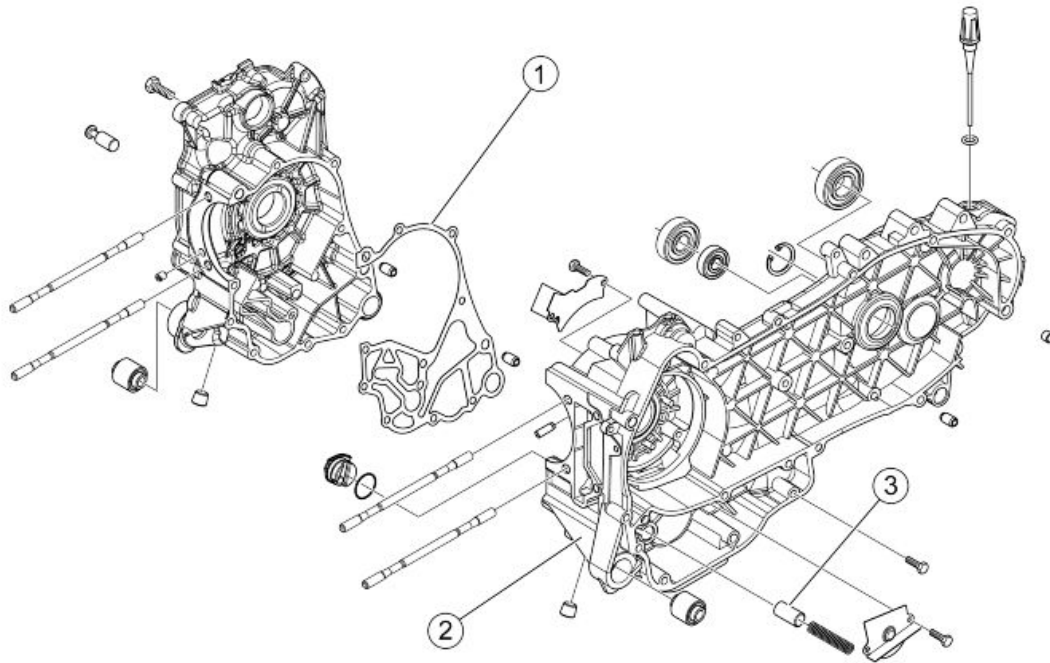
**Crankcase****CRANKCASE**

	<b>Code</b>	<b>Action</b>	<b>Duration</b>
1	001153	Crankcase halves gasket - Replacement	
2	001133	Engine crankcase - Replacement	
3	001124	Lubrication by pass - Replacement	

**Crankshaft**

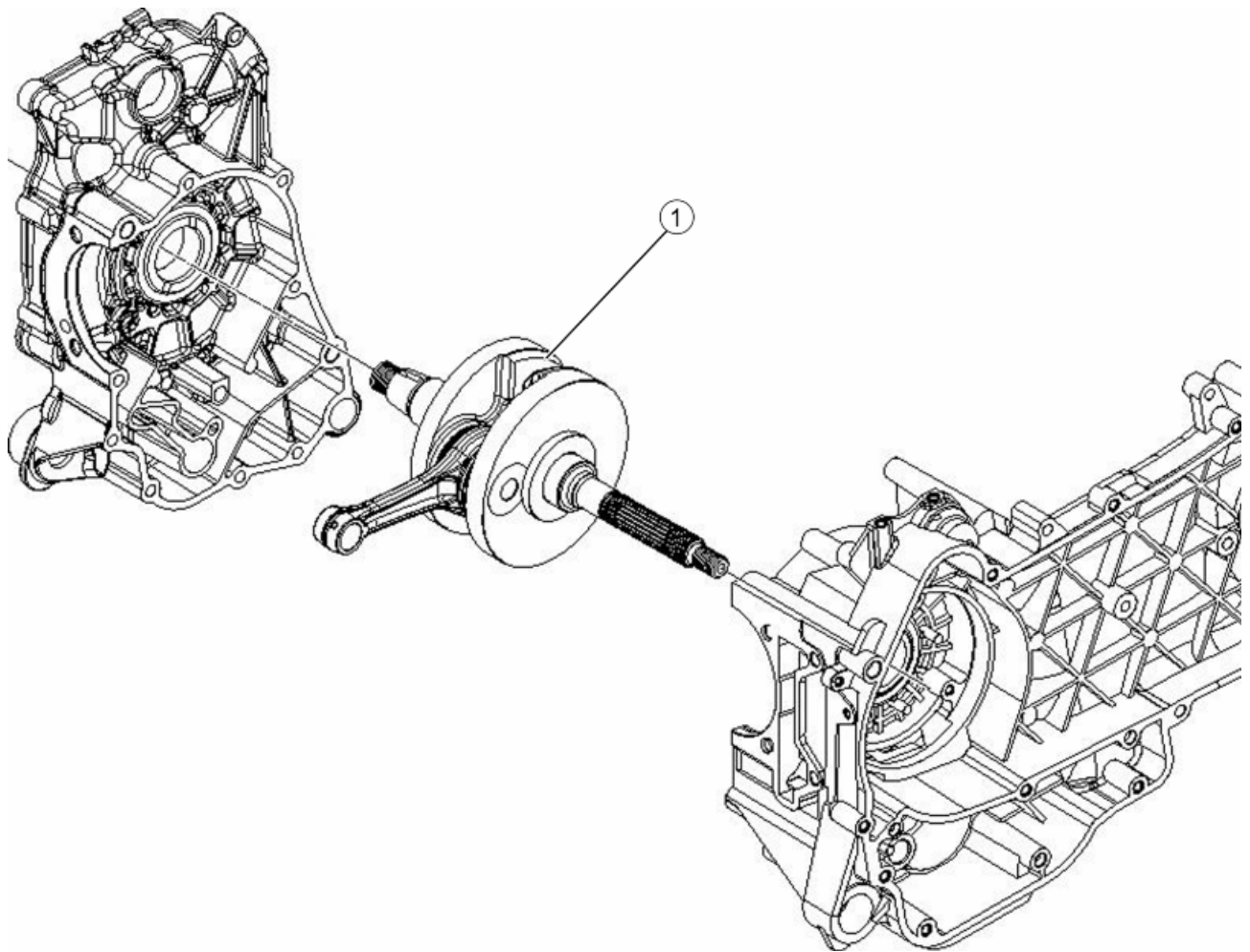

**CRANKSHAFT**

	<b>Code</b>	<b>Action</b>	<b>Duration</b>
1	001117	Crankshaft - Replacement	

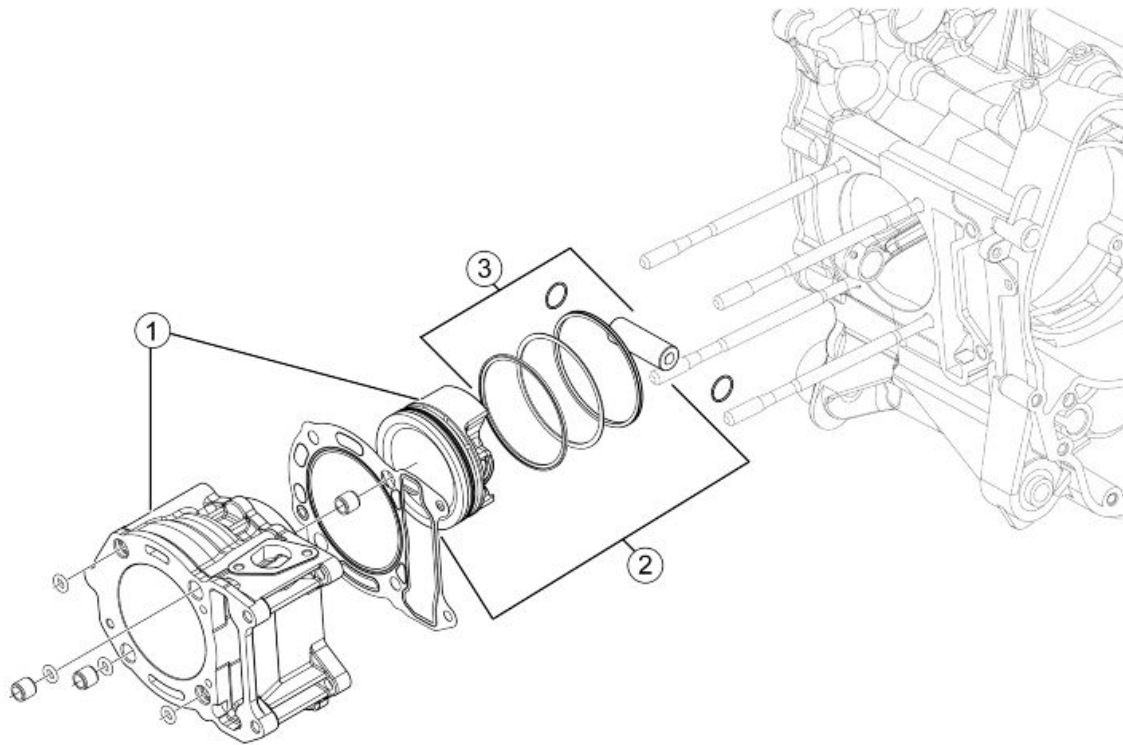
**Cylinder assy.****CYLINDER - PISTON**

	<b>Code</b>	<b>Action</b>	<b>Duration</b>
1	001002	Cylinder / Piston - Replacement	
2	001154	Pistonsrings-pin assembly - Service	
3	001176	Rings / Pin - Replacement	



Cylinder head assy.

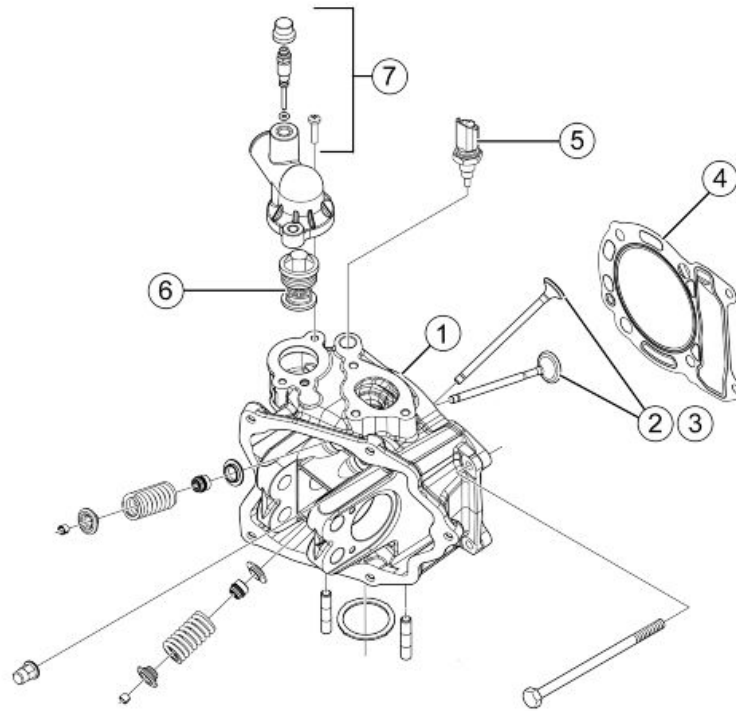

**VALVE HEAD**

	<b>Code</b>	<b>Action</b>	<b>Duration</b>
1	001126	Head - Replacement	
2	001045	Valves - Replacement	
3	001049	Valves - adjust	
4	001056	Head gasket - change	
5	000235	Coolant temperature sensor - Repl.	
6	001057	Thermostat - Replacement	
7	007012	Coolant bleed valve - Replacement	

## Rocker arms support assy.

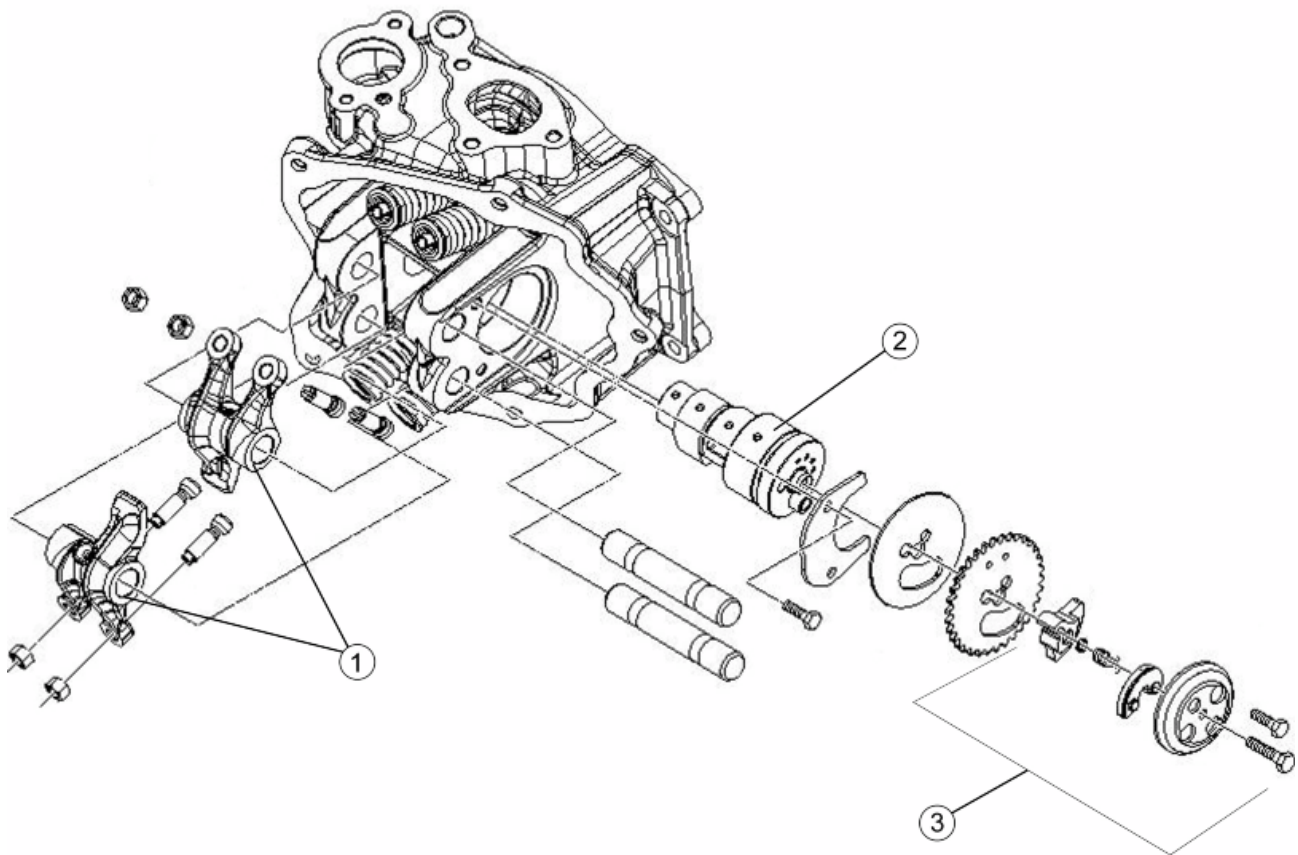

### CAMSHAFT

	Code	Action	Duration
1	001148	Rockers valves - Replacement	
2	001044	Camshaft - Replacement	
3	001169	Pressure reducer - Replacement	

Cylinder head cover

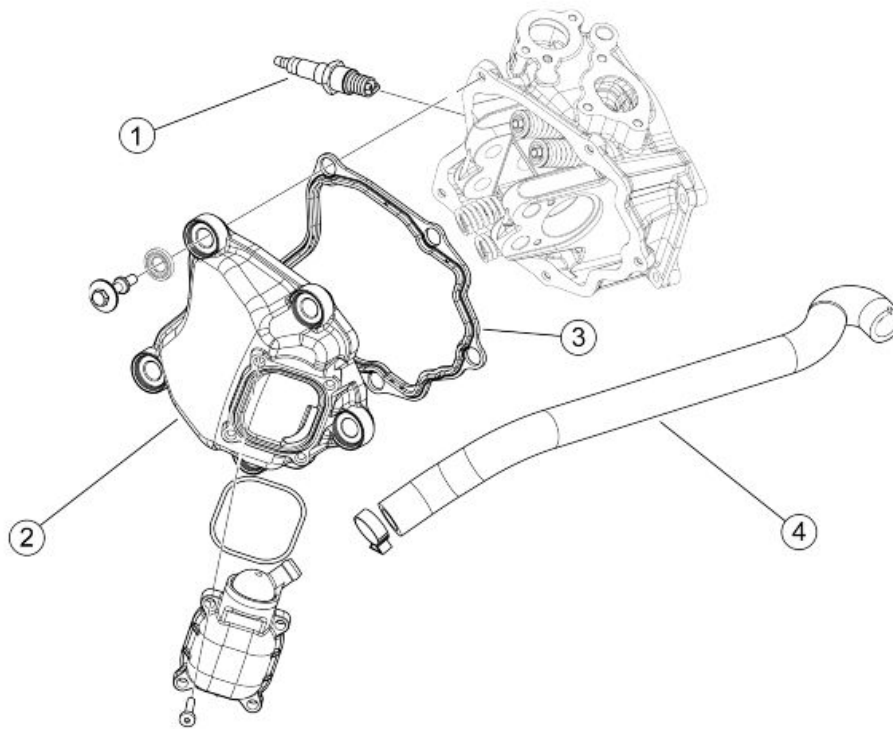

**HEAD COVER**

	<b>Code</b>	<b>Action</b>	<b>Duration</b>
1	001093	Spark plug - Replacement	
2	001089	Head cover - Replacement	
3	001088	Head cover gasket - Replacement	
4	001074	Oil vapour recovery pipe - Replacement	

## Oil filter

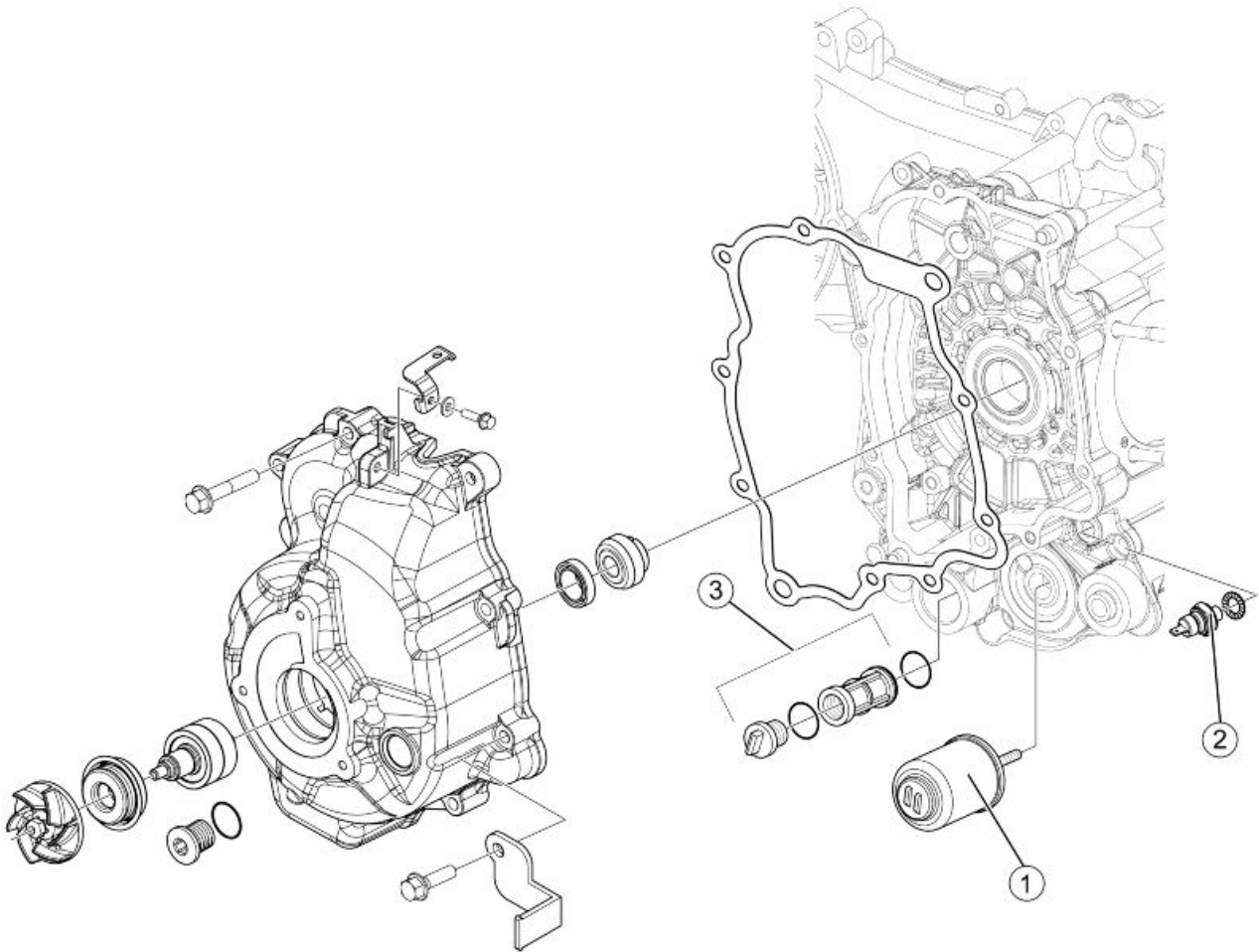
**OIL FILTER**

	<b>Code</b>	<b>Action</b>	<b>Duration</b>
1	001123	Oil filter -Replacement	
2	001160	Oil pressure sensor - change	
3	001102	Net oil filter - change / Cleaning	

Flywheel cover

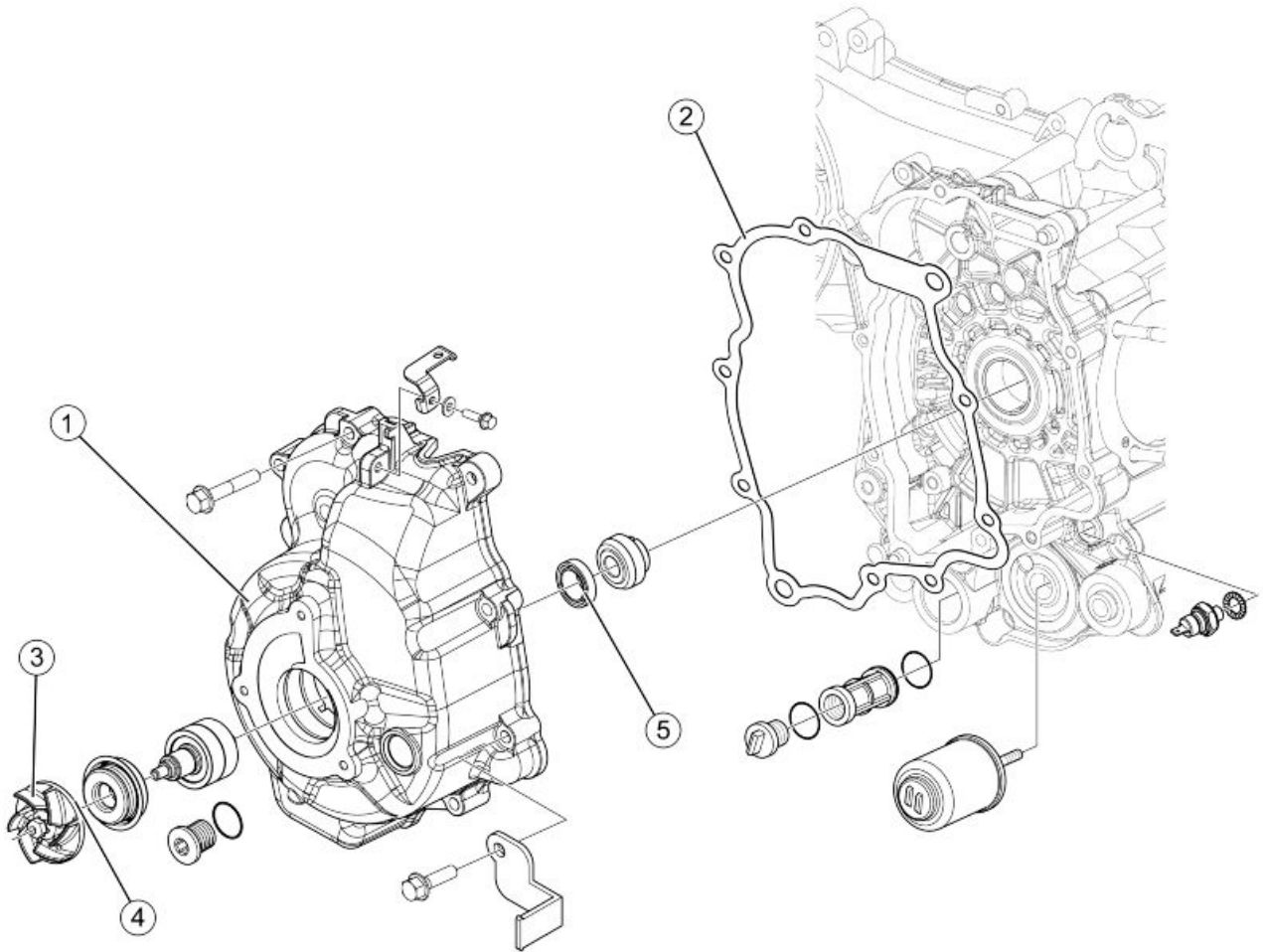

**FLYWHEEL COVER**

	<b>Code</b>	<b>Action</b>	<b>Duration</b>
1	001087	Flywheel cover - Replacement	
2	001150	Flywheel cover gasket - change	
3	007007	Water pump rotor - Replacement	
4	001113	Water pump / Pump rotor - Replacement	
5	001099	Flywheel-side oil seal - Replacement	

## Driven pulley

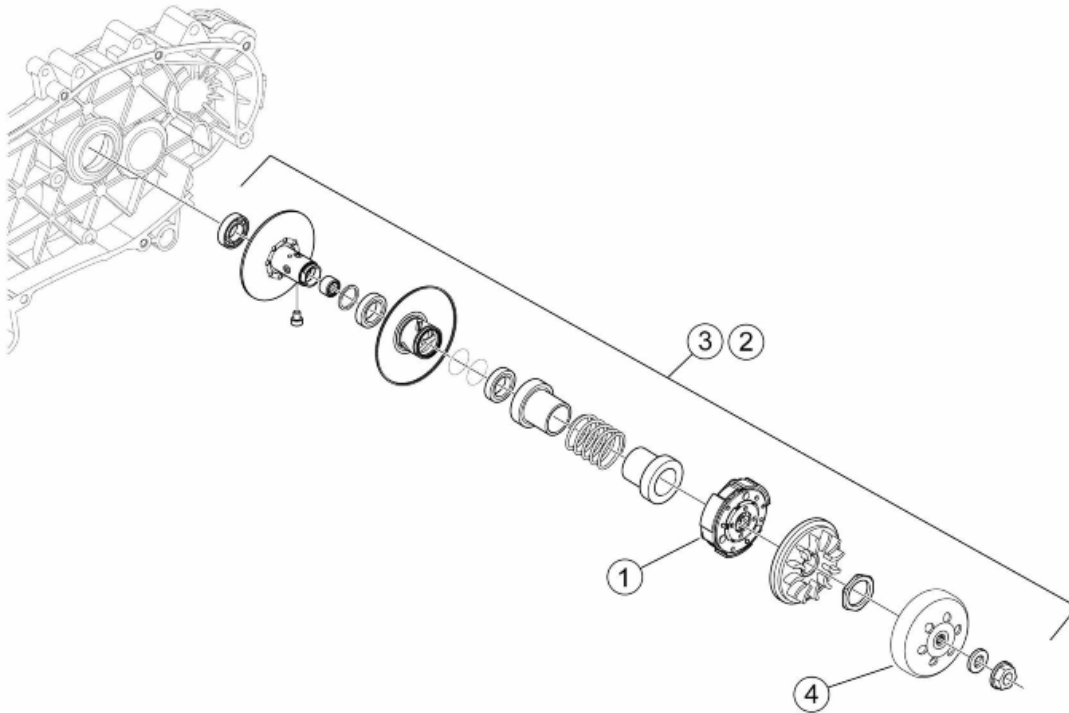

### DRIVEN PULLEY

	Code	Action	Duration
1	001022	Clutch - Replacement	
2	001012	Driven pulley - overhaul	
3	001110	Driven pulley- Replacement	
4	001155	Clutch housing - Replacement	

Oil pump

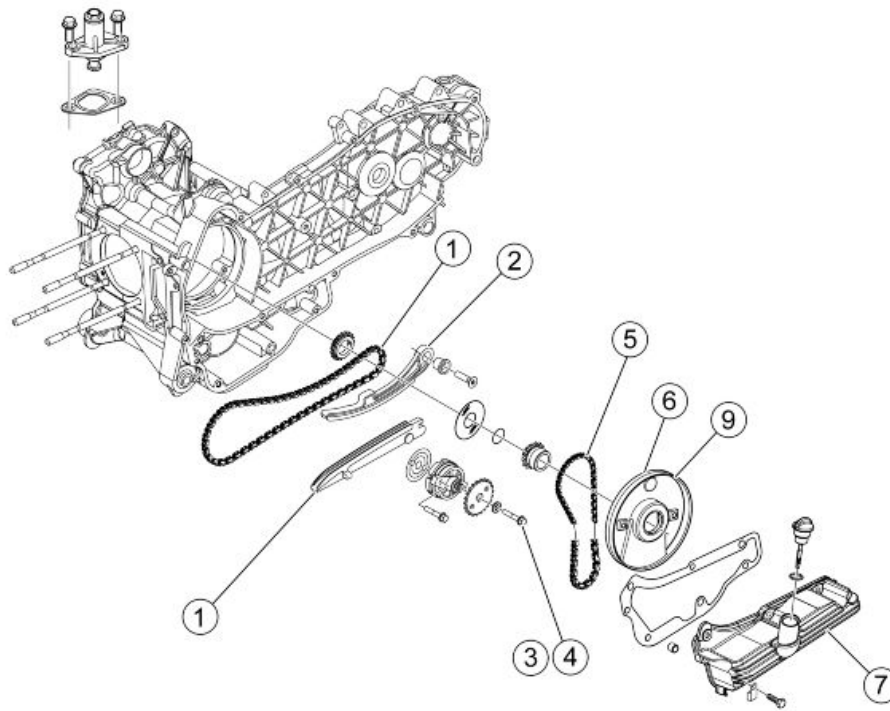

**OIL PUMP**

	<b>Code</b>	<b>Action</b>	<b>Duration</b>
1	001125	Chain guide pads - Replacement	
2	001051	Distribution belt - Timing chain - Replacement	
3	001042	Oil pump - overhaul	
4	001112	Oil pump - change	
5	001122	Oil pump chain - Replacement	
6	001172	Chain cover flap - change	
7	001130	Oil sump - change	
8	001129	Chain tensioner - Service and Replacement	
9	888133	Chain cover flap - Check / replacement	

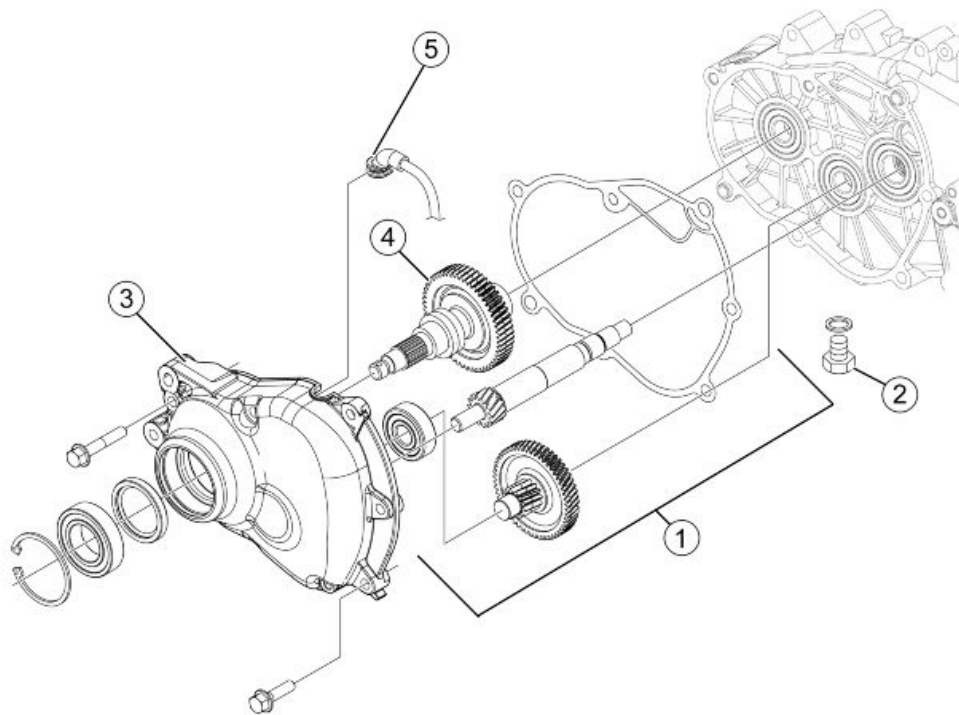
**Final gear assy.****FINAL REDUCTION GEAR**

	<b>Code</b>	<b>Action</b>	<b>Duration</b>
1	001010	Reduction gear - Replacement	
2	003065	Gear box oil - Replacement	
3	001156	Reduction gear cover - Replacement	
4	004125	Rear wheel axle - Replacement	
5	004180	Reduction gear pipe - replace	



**Driving pulley**

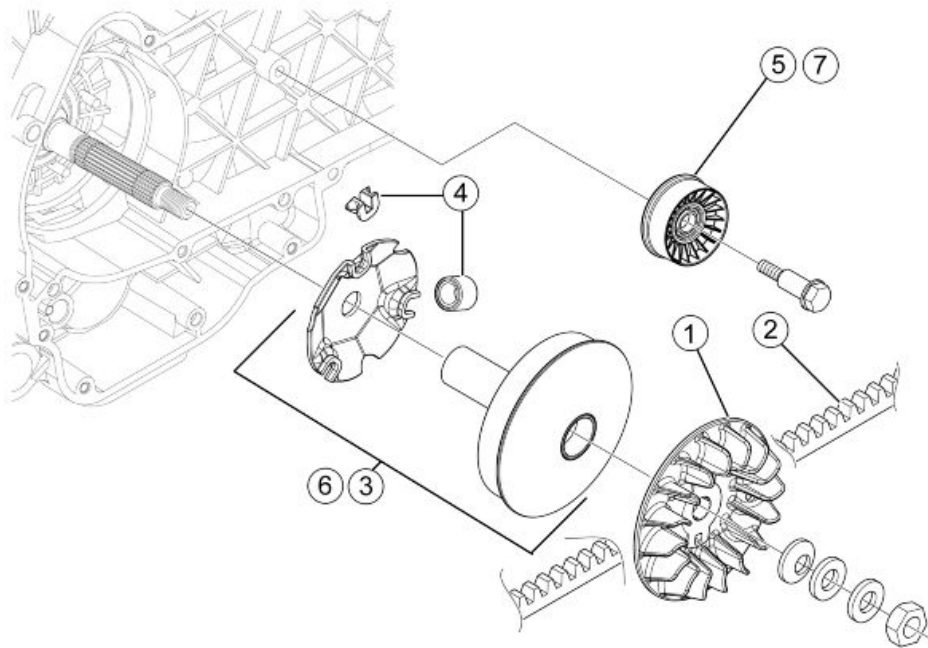

**DRIVING PULLEY**

	<b>Code</b>	<b>Action</b>	<b>Duration</b>
1	001086	Driving half-pulley - Replacement	
2	001011	Drive belt - Replacement	
3	001066	Driving pulley - Removal and refitting	
4	001177	CVT rollers / sliders - Replacement	
5	001141	Belt anti-flapping roller - Replacement	
6	001006	Driving pulley - Service	
7	001175	Anti-flapping roller/ Belt - Service	

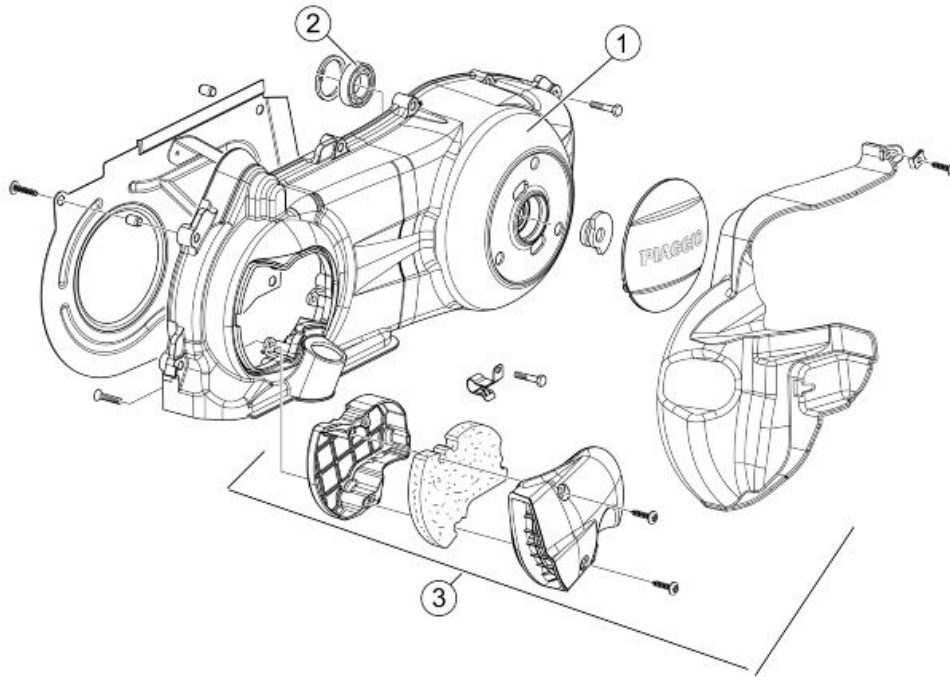
**Transmission cover****TRANSMISSION COVER**

	<b>Code</b>	<b>Action</b>	<b>Duration</b>
1	001096	Transmission crankcase cover - Replacement	
2	001135	Transmission cover bearing - Replacement	
3	001170	Air deflector - Replacement	

**Water pump**

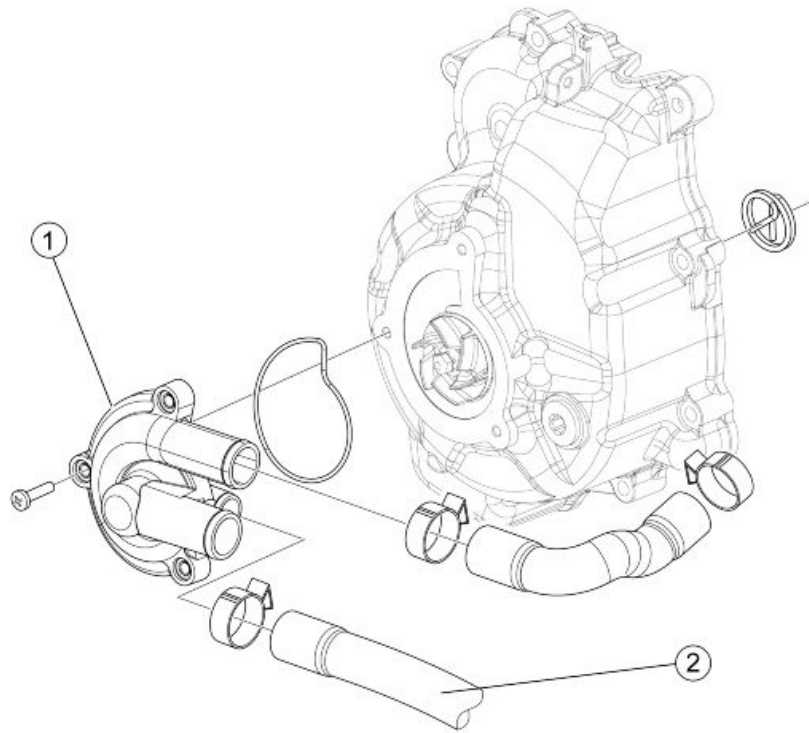

**WATER PUMP**

	<b>Code</b>	<b>Action</b>	<b>Duration</b>
1	007017	Water pump cover - Replacement	
2	007009	Head-pump by-pass rubber sleeve - Replacement	

## Starter motor

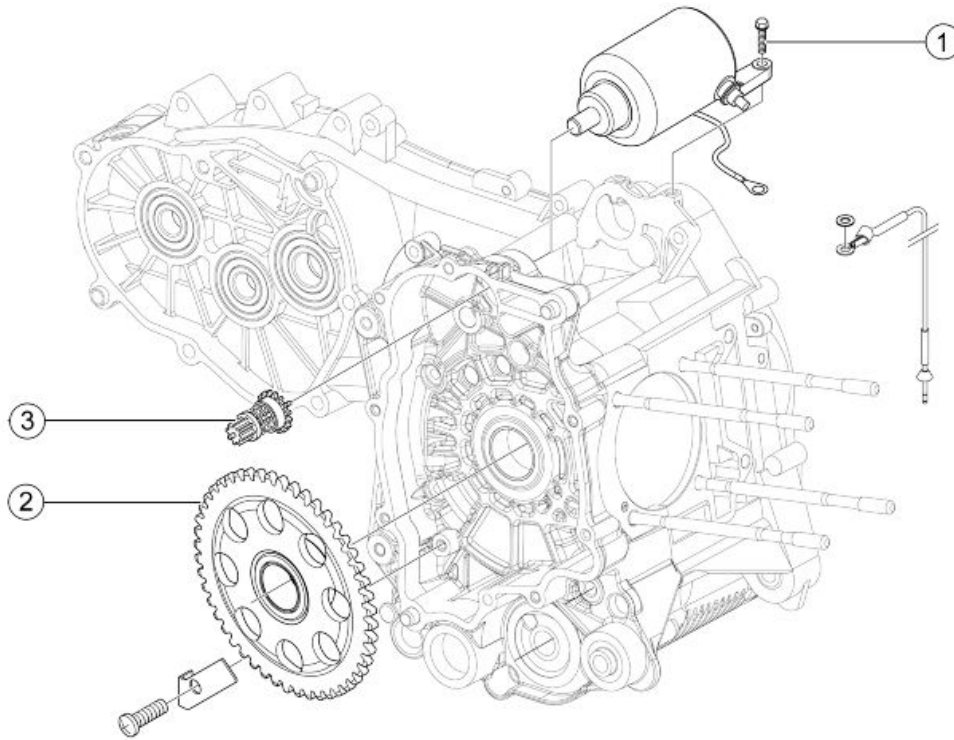

### ELECTRIC STARTER

	Code	Action	Duration
1	001020	Starter motor - Replacement	
2	001151	Starter driven gearing - Replacement	
3	001017	Start-up pinion - Replacement	

Flywheel magneto

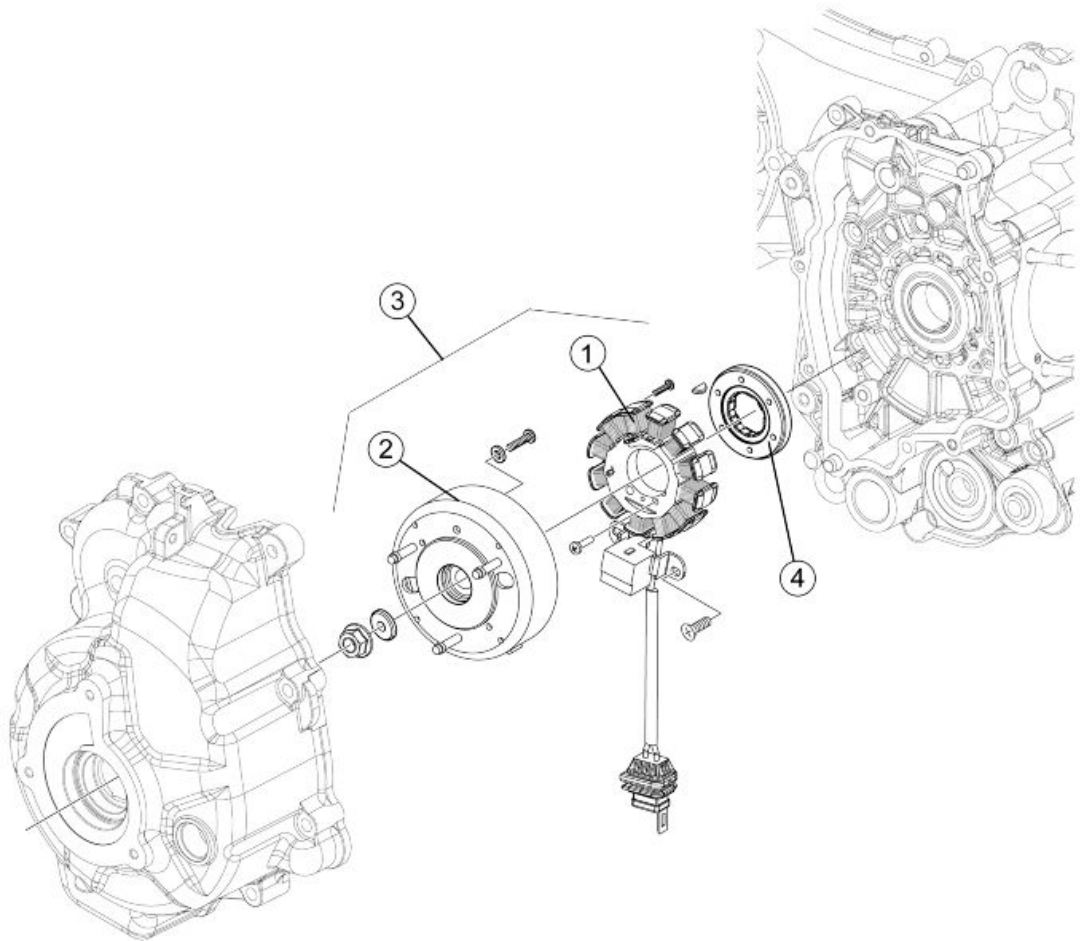

**MAGNETO FLYWHEEL**

	<b>Code</b>	<b>Action</b>	<b>Duration</b>
1	001067	Stator - Removal and Refitting	
2	001173	Rotor - Replacement	
3	001058	Complete flywheel - change	
4	001104	Start-up freewheel - Replacement	

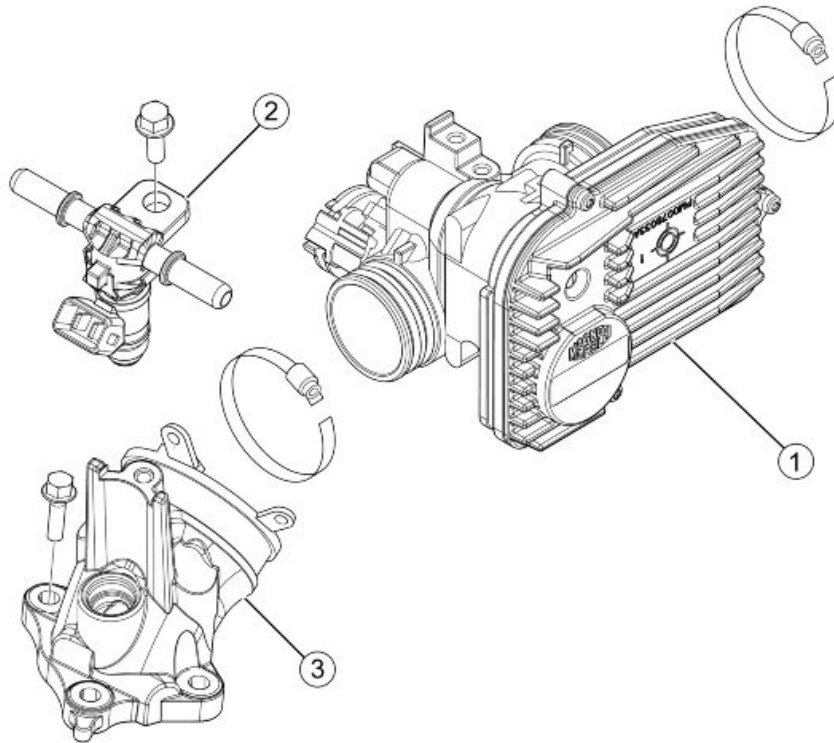
**Butterfly valve****THROTTLE BODY**

	<b>Code</b>	<b>Action</b>	<b>Duration</b>
1	001166	Throttle body - Replacement	
2	001047	Injector - Replacement	
3	001013	Intake manifold - change	

Exhaust pipe

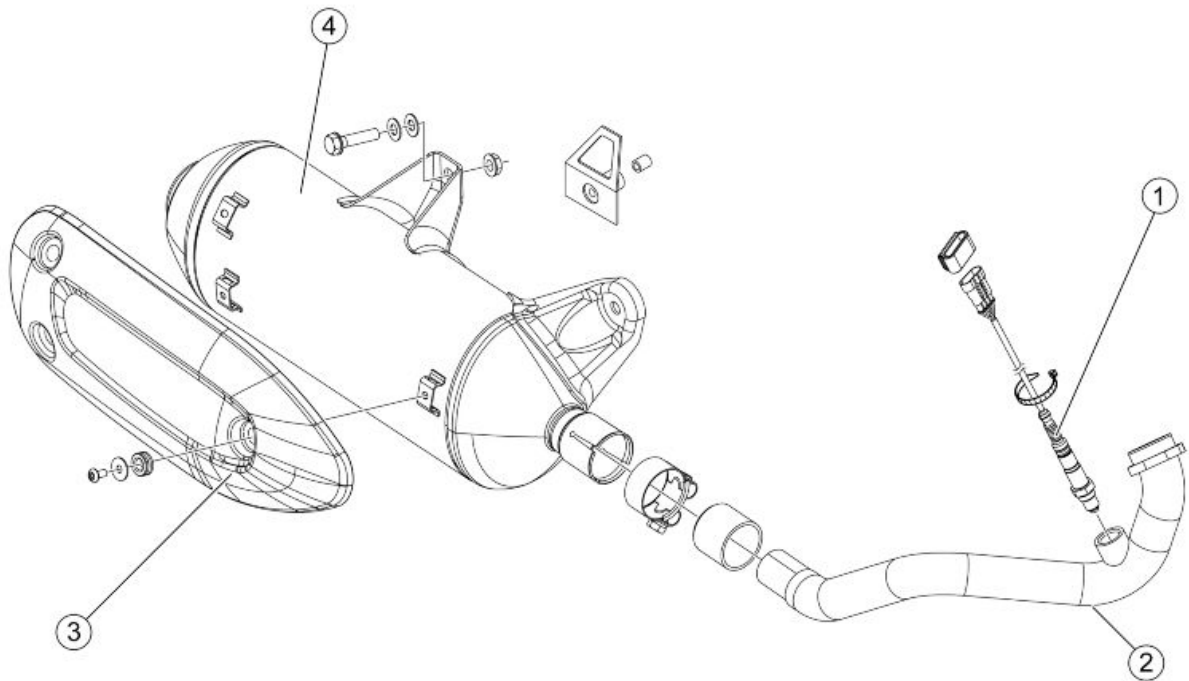

**MUFFLER**

	<b>Code</b>	<b>Action</b>	<b>Duration</b>
1	005138	Lambda probe - Replacement	
2	001092	Exhaust manifold - Replacement	
3	001095	Silencer heatshield - Replacement	
4	001009	Silencer - Replacement	

## Air cleaner

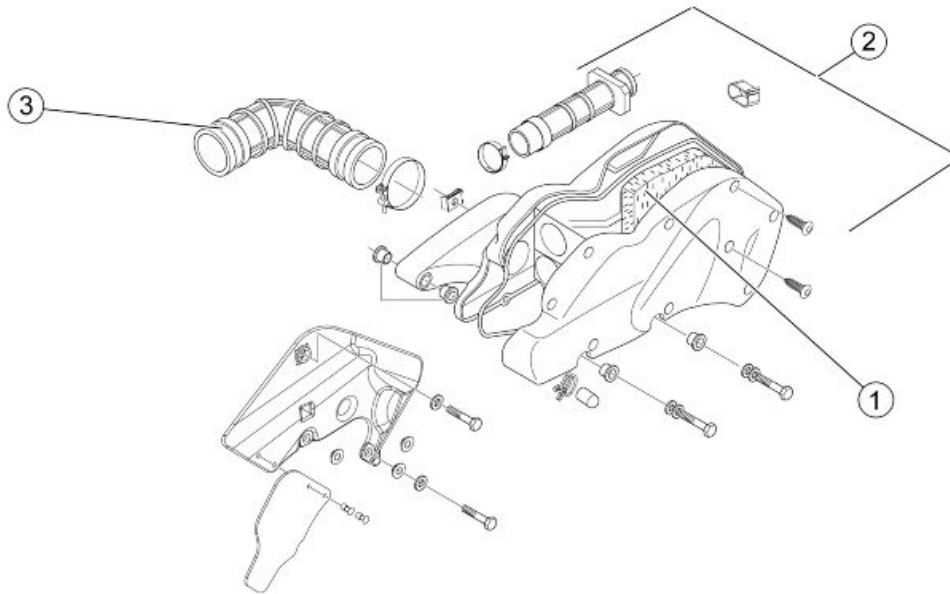

### AIR CLEANER

	Code	Action	Duration
1	001015	Air filter box - Replacement	
2	001014	Air filter - Replacement / cleaning	
3	004122	Air cleaner/ carburettor union - Replacement	



Frame

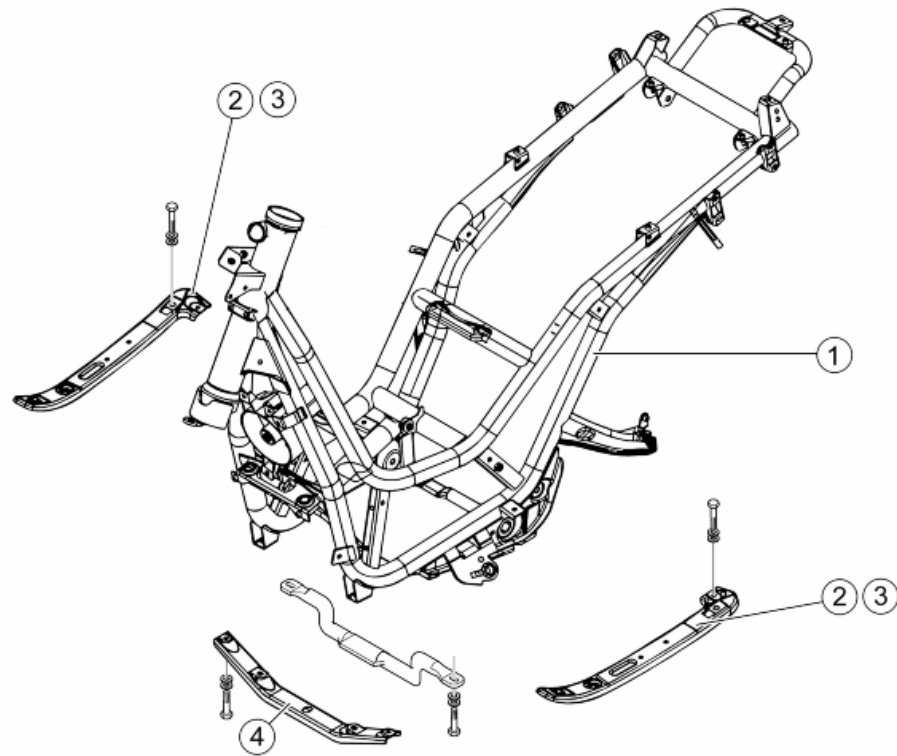

**CHASSIS**

	Code	Action	Duration
1	004001	Chassis - Replacement	
2	004147	footboard support bracket one side - Replacement	
3	004148	Footrest support bracket, both sides - Replacement	
4	004146	Front chassis - Replacement	

## Centre-stand

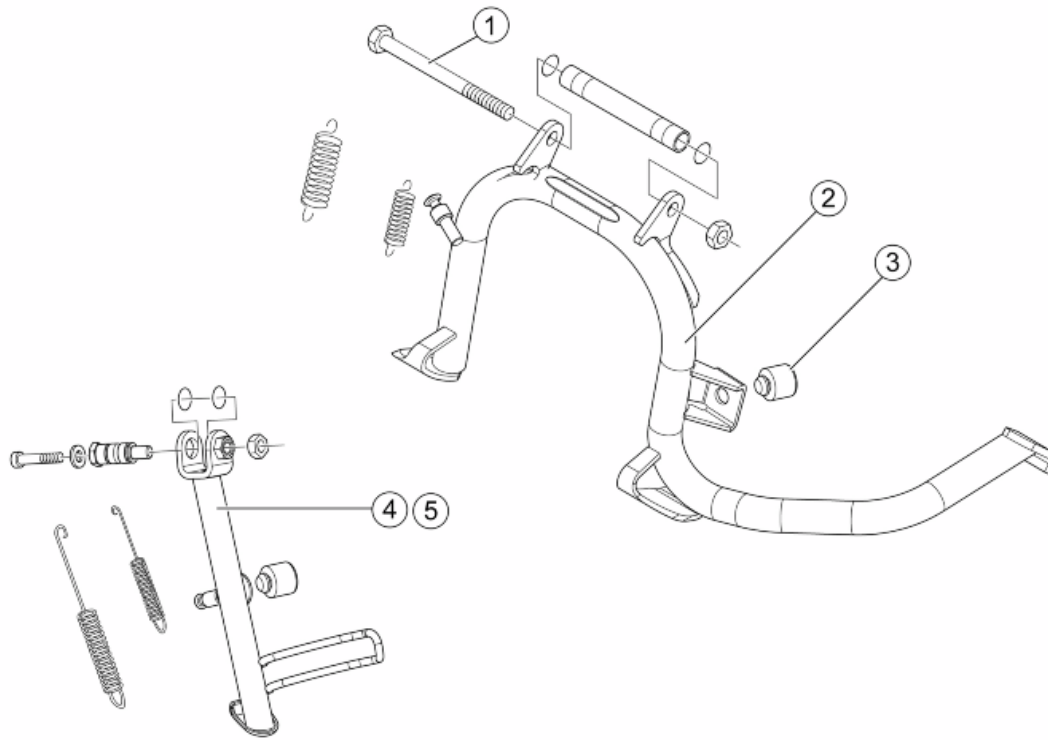
**STAND**

	<b>Code</b>	<b>Action</b>	<b>Duration</b>
1	001053	Stand pin - Replacement	
2	004004	Stand - Replacement	
3	004179	Stand bumper - Replacement	
4	004102	Side stand - Replacement	
5	005079	Stand switch - Replacement	

Legshield spoiler

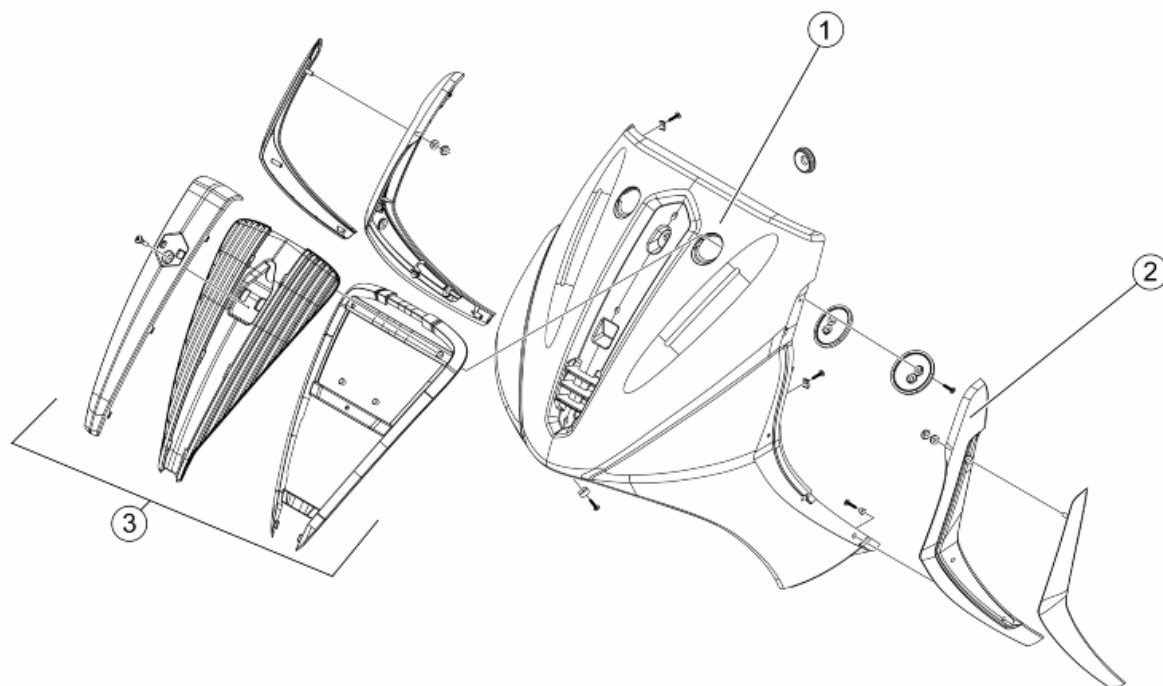

**LEGSIELD - SPOILER**

	<b>Code</b>	<b>Action</b>	<b>Duration</b>
1	004064	Legshield, front section - Replacement	
2	004023	Shield rim - Replacement	
3	004149	shield central cover - Replacement	

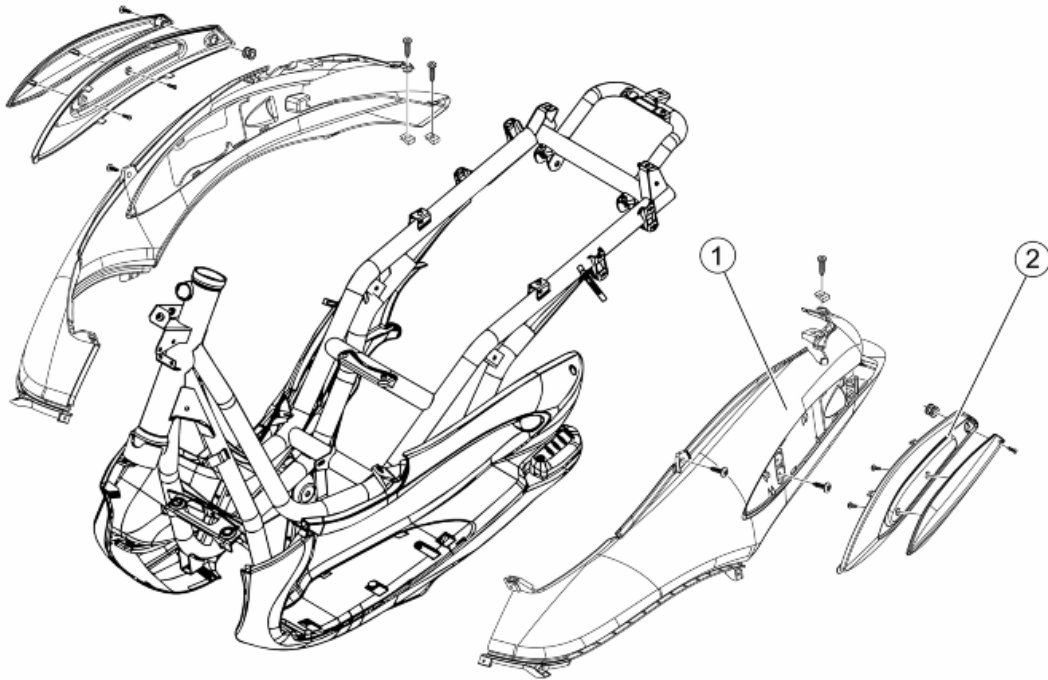
**Side fairings****SIDE COVERS**

	<b>Code</b>	<b>Action</b>	<b>Duration</b>
1	004012	Rear side panels - Replacement	
2	004129	Rear fairing - Replacement	

Rear cover

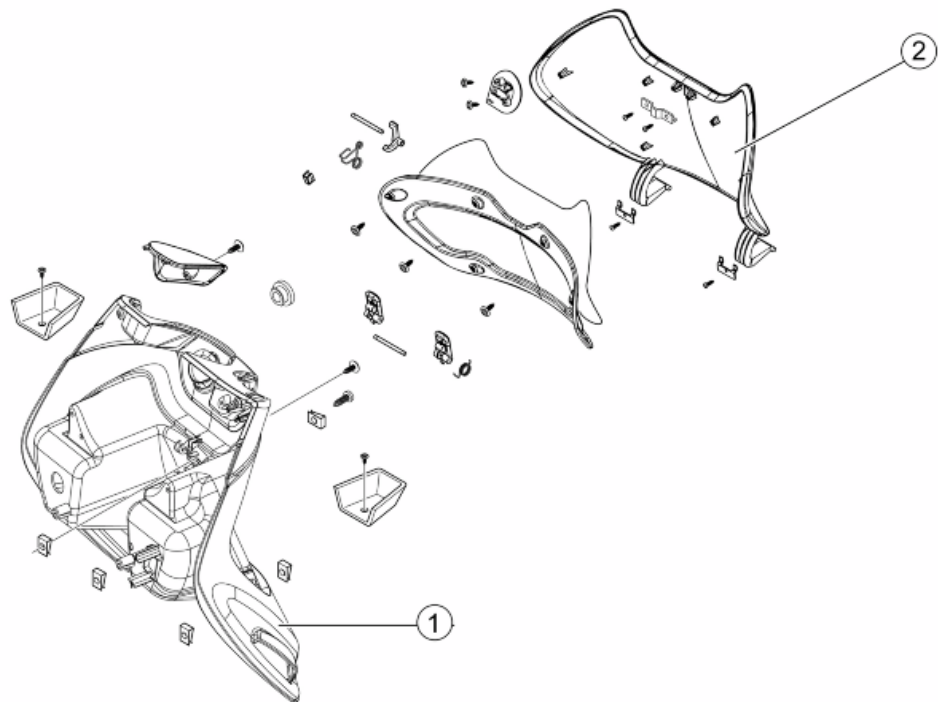

**REAR SHIELD**

	<b>Code</b>	<b>Action</b>	<b>Duration</b>
1	004065	Shield back plate - Replacement	
2	004081	Top box lid - Replacement	

## Central cover

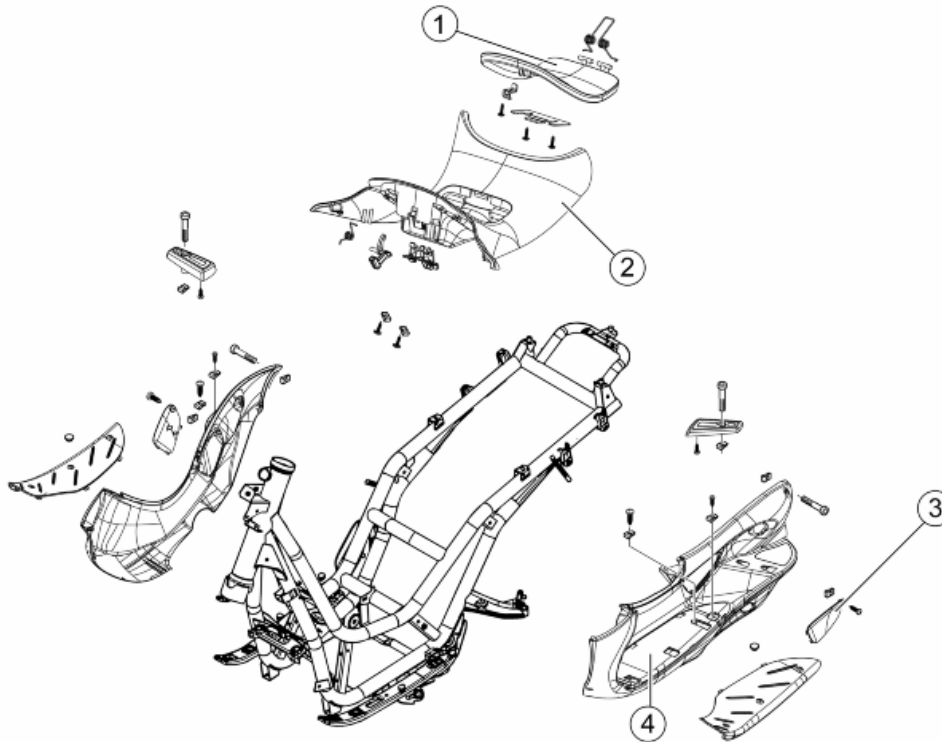

### CENTRAL COVER

	Code	Action	Duration
1	004135	Fuel tank port - Replacement	
2	004011	Central chassis cover - Replacement	
3	004059	Spark plug inspection flap - Replacement	
4	004015	Footrest - Replacement	

**Underseat compartment**

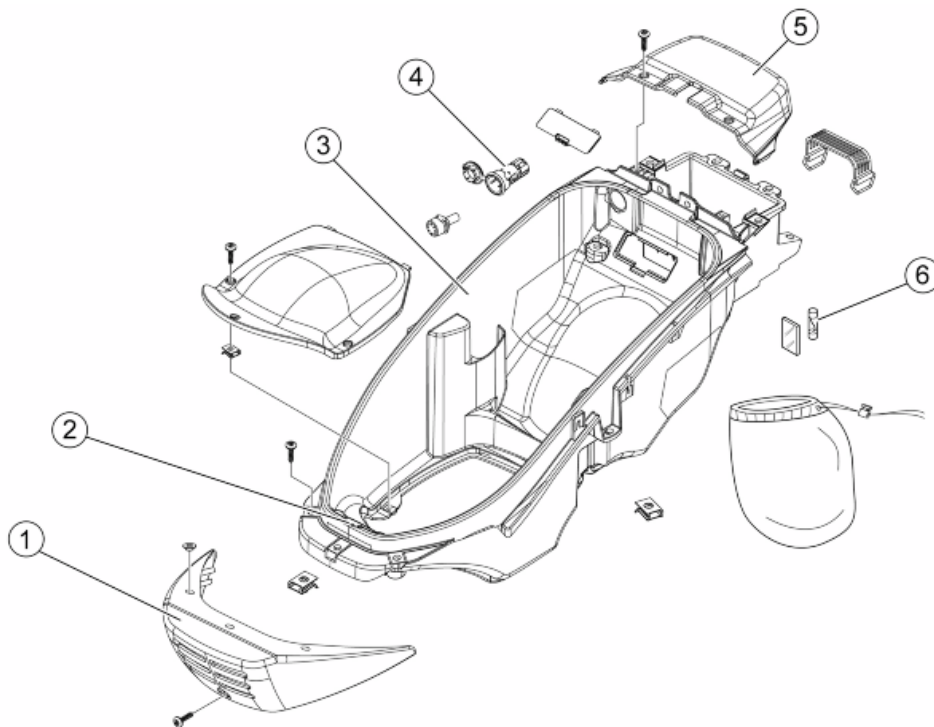

**HELMET COMPARTMENT**

	<b>Code</b>	<b>Action</b>	<b>Duration</b>
1	004106	Helmet compartment band - Replacement	
2	005033	Glove-box light switch - Replacement	
3	004016	Helmet compartment - Replacement	
4	004112	Cock / carburettor hose - Replacement	
5	005046	Battery cover - change	
6	005026	Helmet compartment bulb - Replacement	

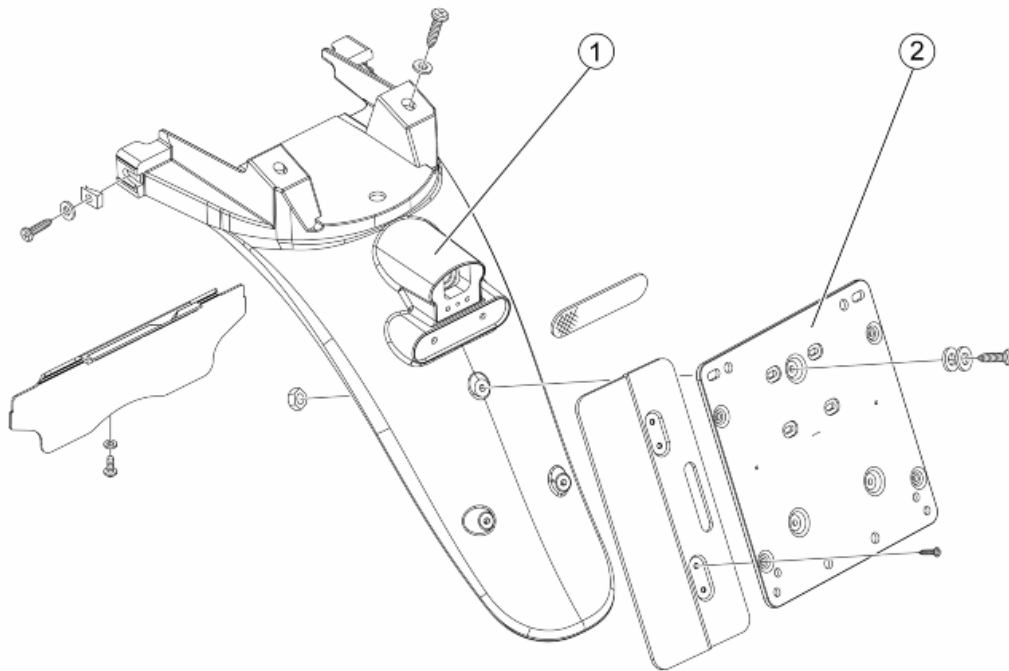
**Plate holder****LICENSE PLATE HOLDER**

	<b>Code</b>	<b>Action</b>	<b>Duration</b>
1	004136	License plate holder mounting - Replacement	
2	005048	number plate holder - Replacement	



**Mudguard**

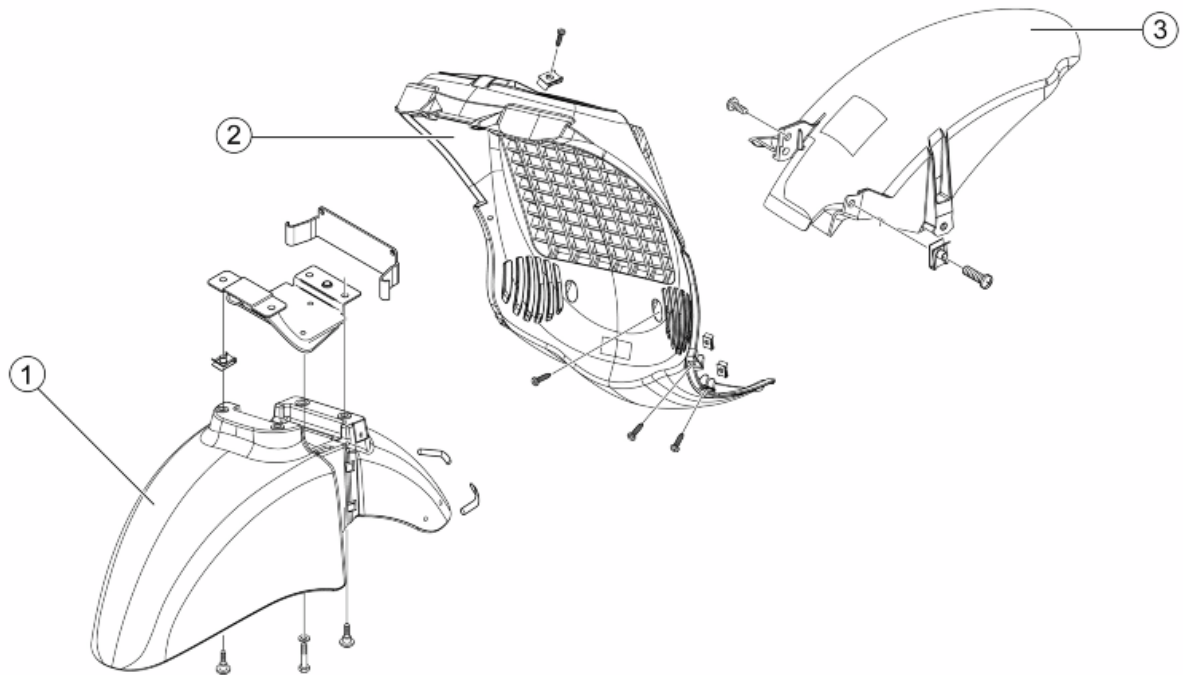

**MUDGUARDS**

	<b>Code</b>	<b>Action</b>	<b>Duration</b>
1	004002	Front mudguard - change	
2	004053	Spoiler - Replacement	
3	004009	Rear mudguard - Replacement	

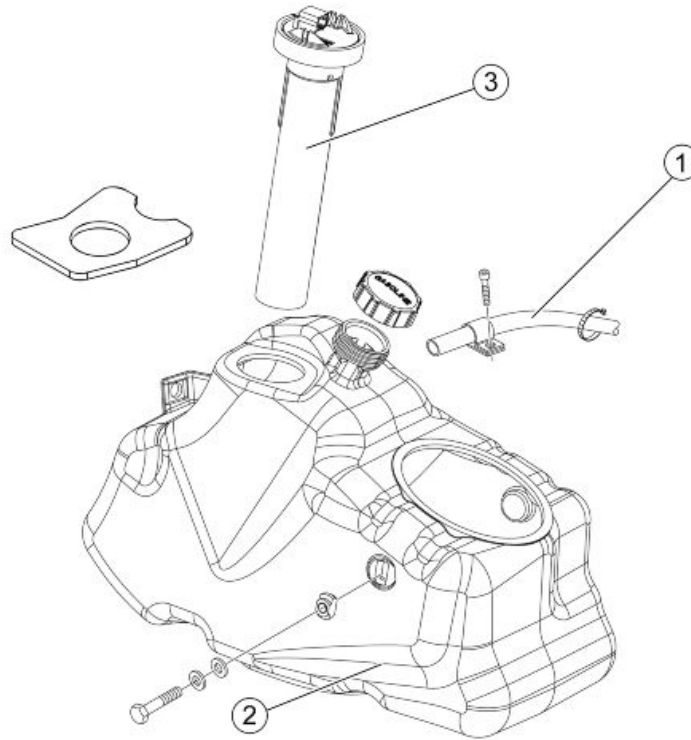
**Fuel tank****FUEL TANK**

	<b>Code</b>	<b>Action</b>	<b>Duration</b>
1	004109	Fuel tank breather - change	
2	004005	Fuel tank - Replacement	
3	005010	Tank float - Replacement	

Rear shock-absorber

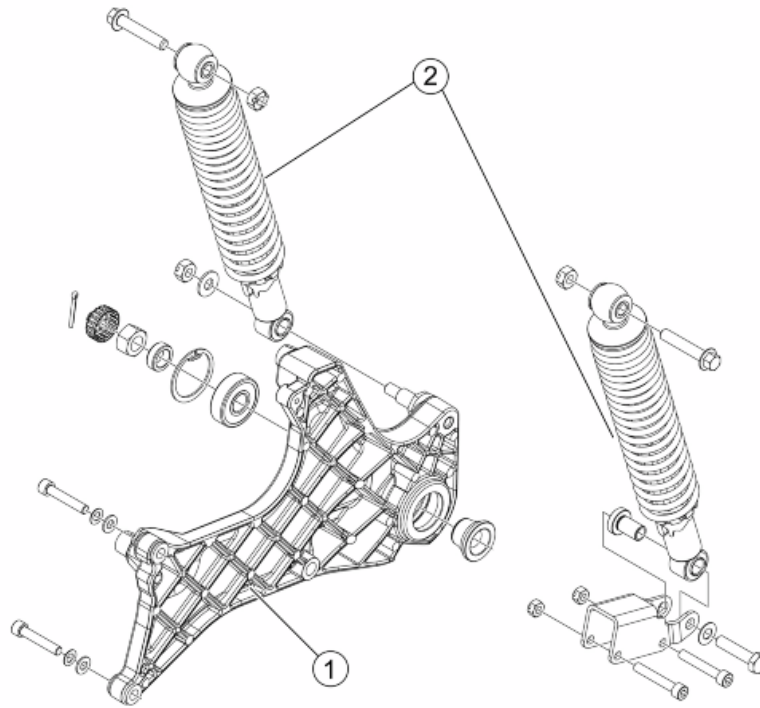

**REAR SHOCK ABSORBER**

	<b>Code</b>	<b>Action</b>	<b>Duration</b>
1	003077	Muffler supporting arm/ rear shock absorber - Replacement	
2	003007	Rear shock absorber - Replacement	

## Handlebar covers

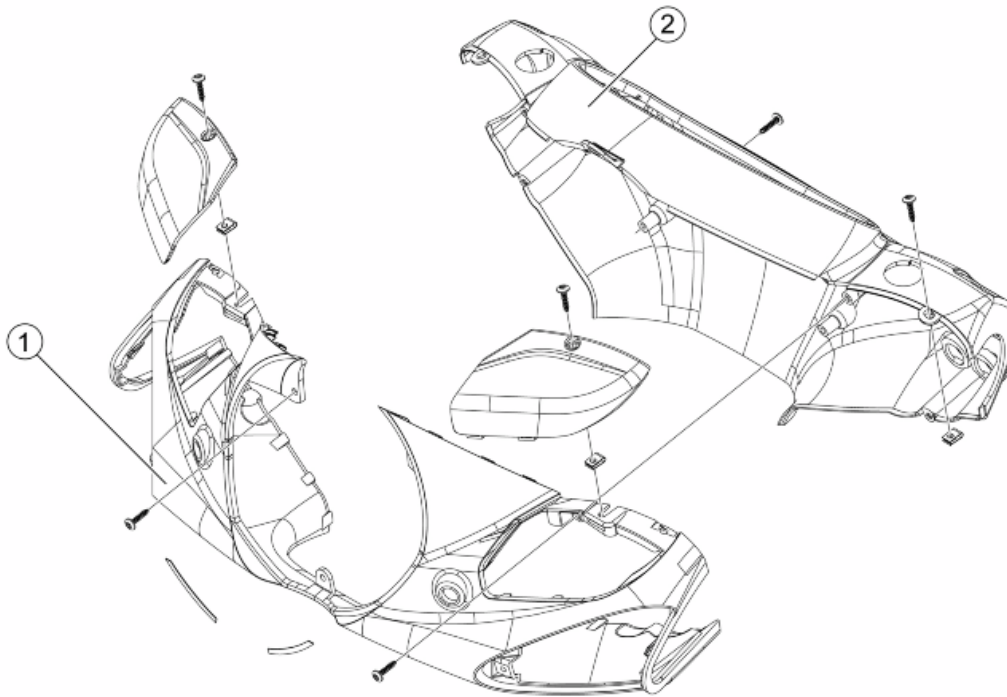

### HANDLEBAR COVERS

	<b>Code</b>	<b>Action</b>	<b>Duration</b>
1	004018	Front handlebar covers - Replacement	
2	004019	Rear handlebar covers - Replacement	

Handlebar components

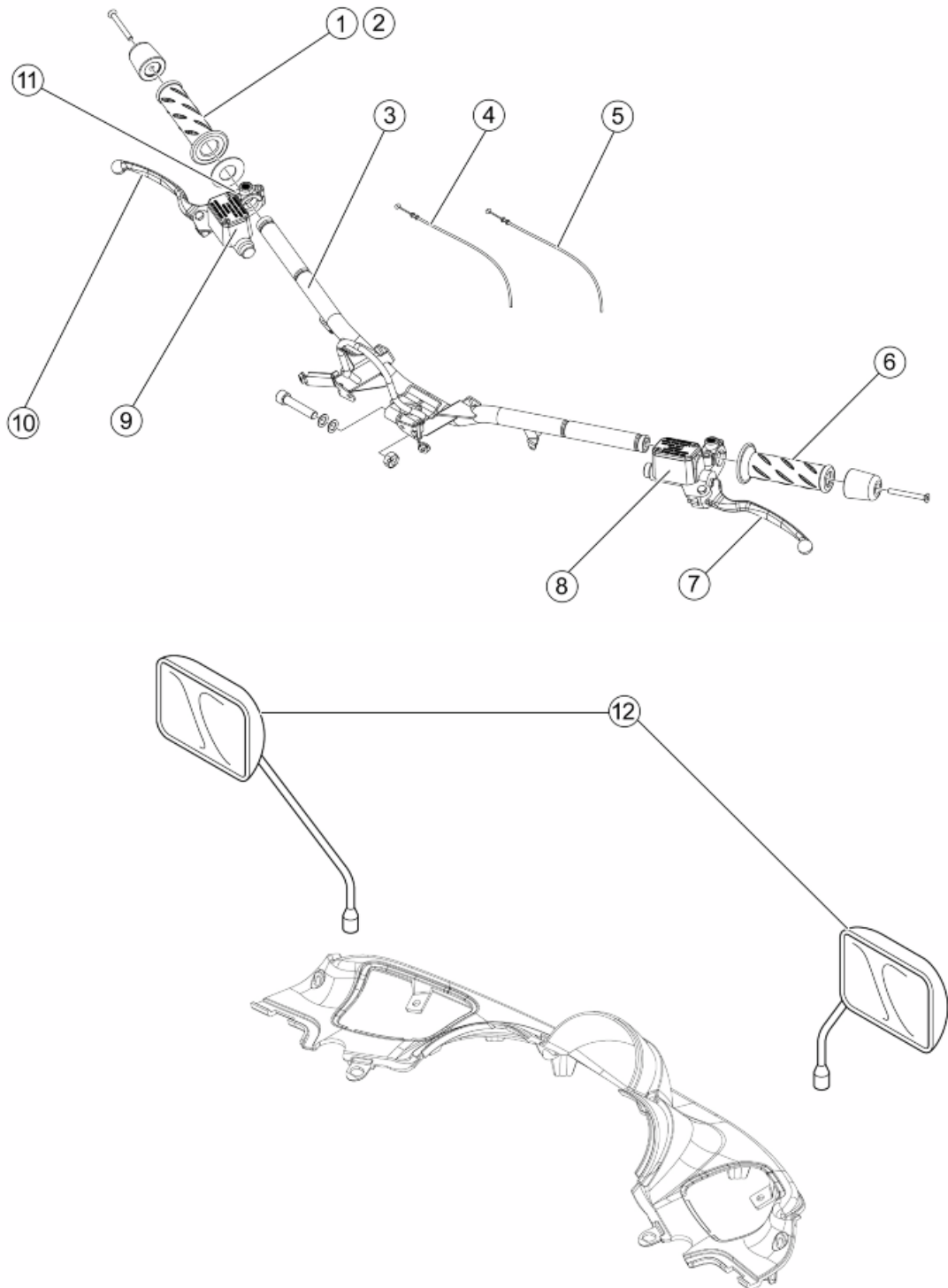

**HANDLEBAR COMPONENTS**

	Code	Action	Duration
1	002060	Complete throttle control - Replacement	
2	002059	Right-hand knob - Replacement	

	Code	Action	Duration
3	003001	Handlebar - Replacement	
4	003061	Accelerator transmission - adjust	
5	002063	Complete throttle transmission - Replacement	
6	002071	Left knob - Replacement	
7	002037	Brake lever - Replacement	
8	002067	Rear brake pump - Replacement	
9	002024	Front brake pump - Replacement	
10	004162	Mirror mounting and/or brake pump fitting U-bolt - Replacement	
11	004066	Driving mirror - Replacement	

## Swing-arm

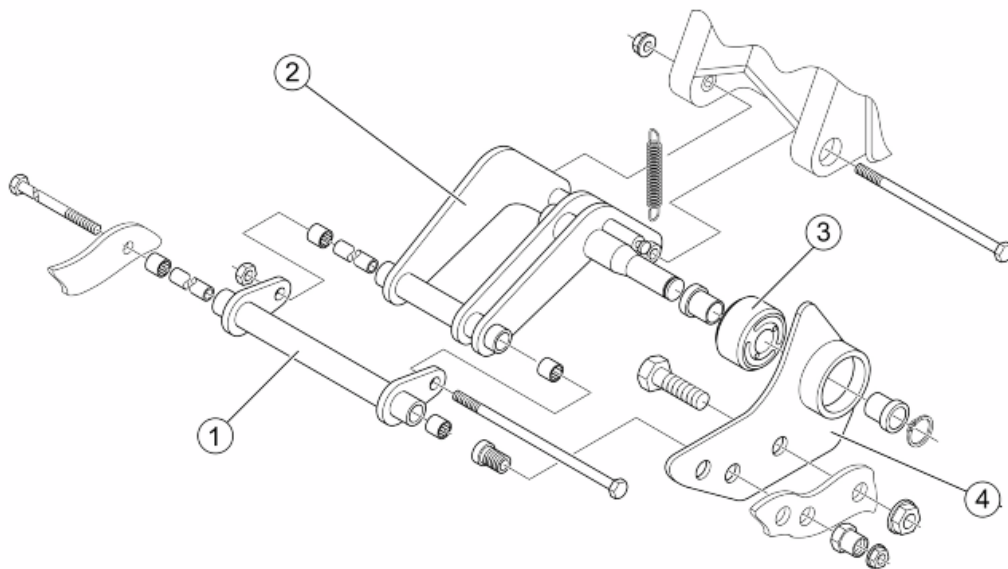

### **SWINGING ARM**

	Code	Action	Duration
1	003080	Swinging arm on frame - Replacement	
2	001072	Engine/chassis swinging arm attachment - Replacement	
3	004058	Silent block - Replacement	
4	003081	Swinging arm support flange - Replacement	

**Brake hoses**

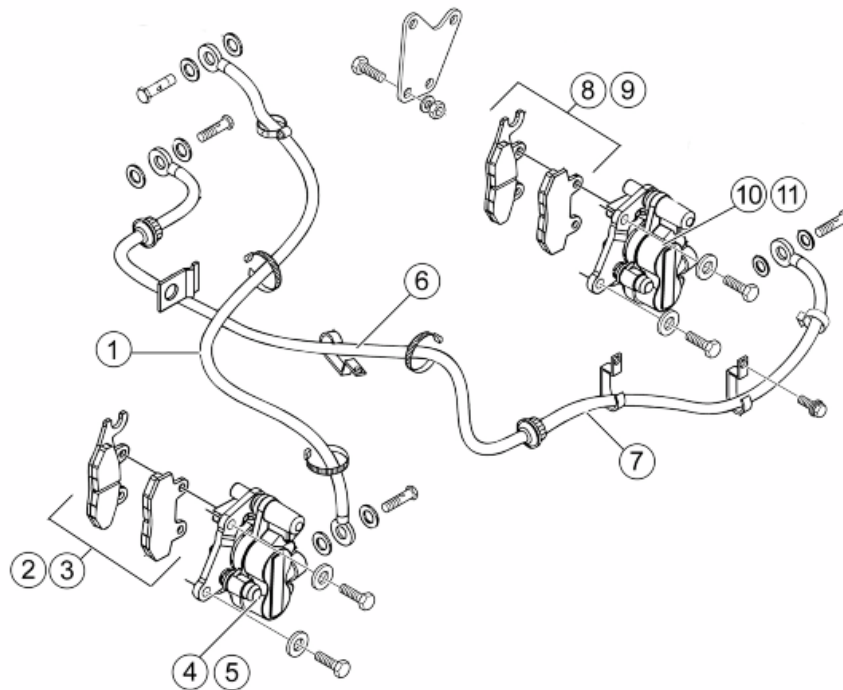

**BRAKE PIPING**

	<b>Code</b>	<b>Action</b>	<b>Duration</b>
1	002021	Front brake piping - Replacement	
2	003070	Front brake pads/shoes - Check for wear	
3	002007	Front brake pads - Replacement	
4	002039	Front brake calliper - Replacement	
5	002047	Front brake fluid and air bleed system - Replacement	
6	002020	Rear brake disc piping - Replacement	
7	002081	Rear brake rigid pipes - Replacement	
8	003071	Rear brake pads/shoes - Check for wear	
9	002002	Rear brake pads - Replacement	
10	002080	Rear brake oil bleed system - Change	
11	002048	Rear brake calliper - Replacement	

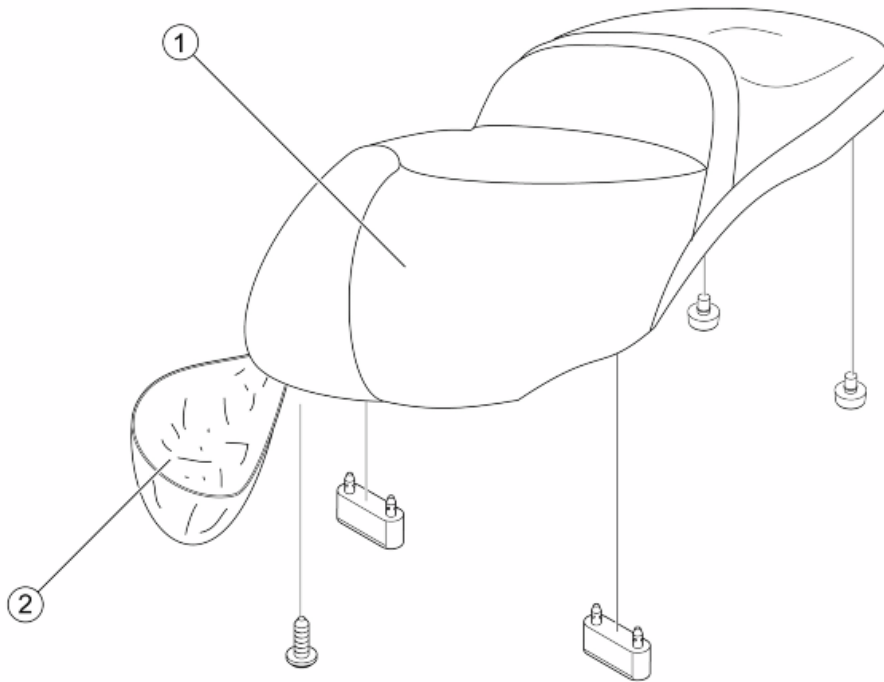
**Seat****SADDLE**

	<b>Code</b>	<b>Action</b>	<b>Duration</b>
1	004003	Saddle - Replacement	
2	004144	Saddle cover - Replacement	



Instrument panel

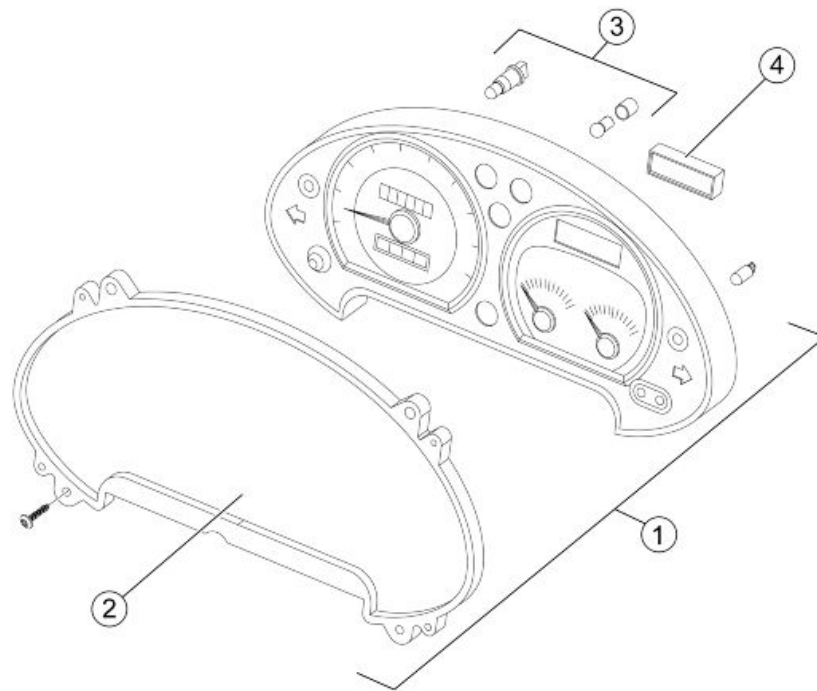

**INSTRUMENT PANEL**

	<b>Code</b>	<b>Action</b>	<b>Duration</b>
1	005014	Odometer - Replacement	
2	005078	Odometer glass - Replacement	
3	005038	Dashboard warning/telltale lights - Replacement	
4	005076	Clock / Cell - Replacement	

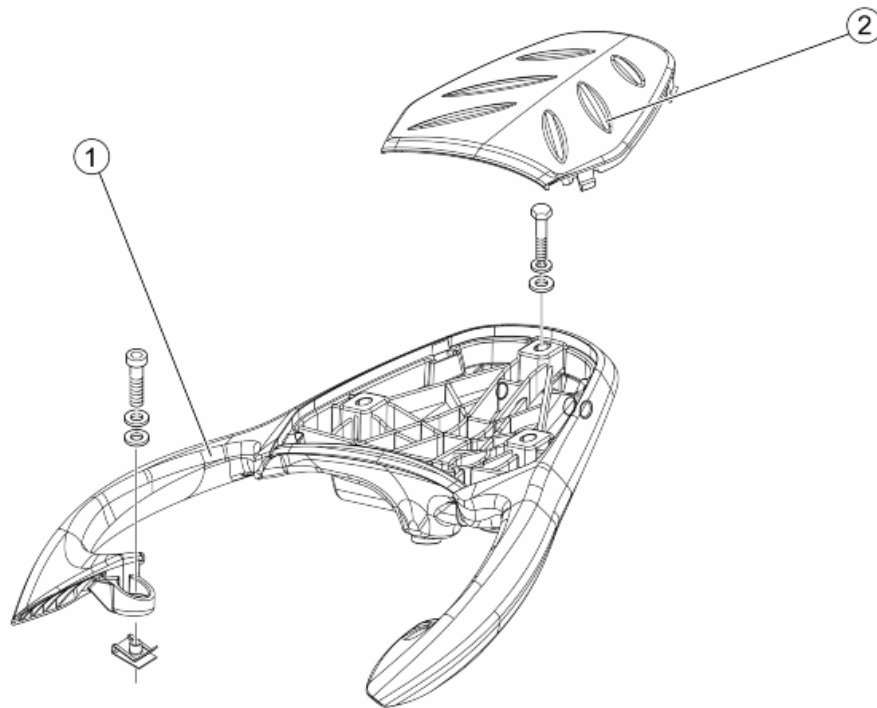
**Rear rack****LUGGAGE RACK**

	<b>Code</b>	<b>Action</b>	<b>Duration</b>
1	004008	Luggage rack - Replacement	
2	004062	Luggage rack cover - Replacement	

**Locks**

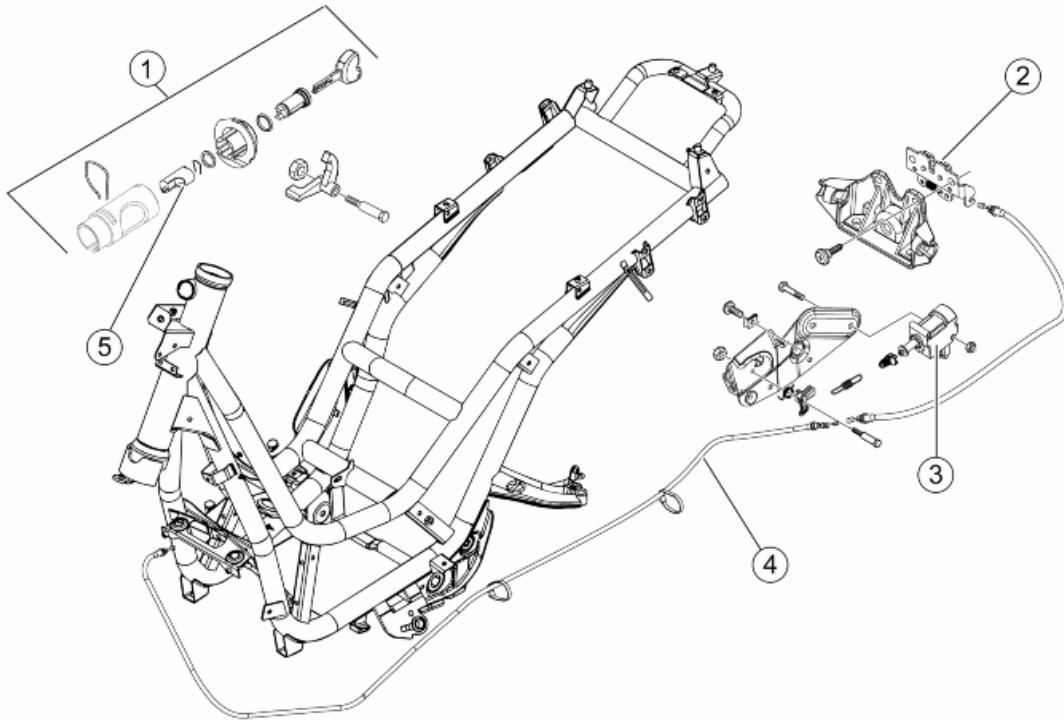

**LOCKS**

	<b>Code</b>	<b>Action</b>	<b>Duration</b>
1	004010	Anti-theft lock - Replacement	
2	004054	Saddle lock catch - Replacement	
3	005099	Electric saddle opening device - Replacement	
4	002083	Saddle opening transmission - Replacement	
5	005072	Immobilizer aerial - Replacement	

Turn signal lights

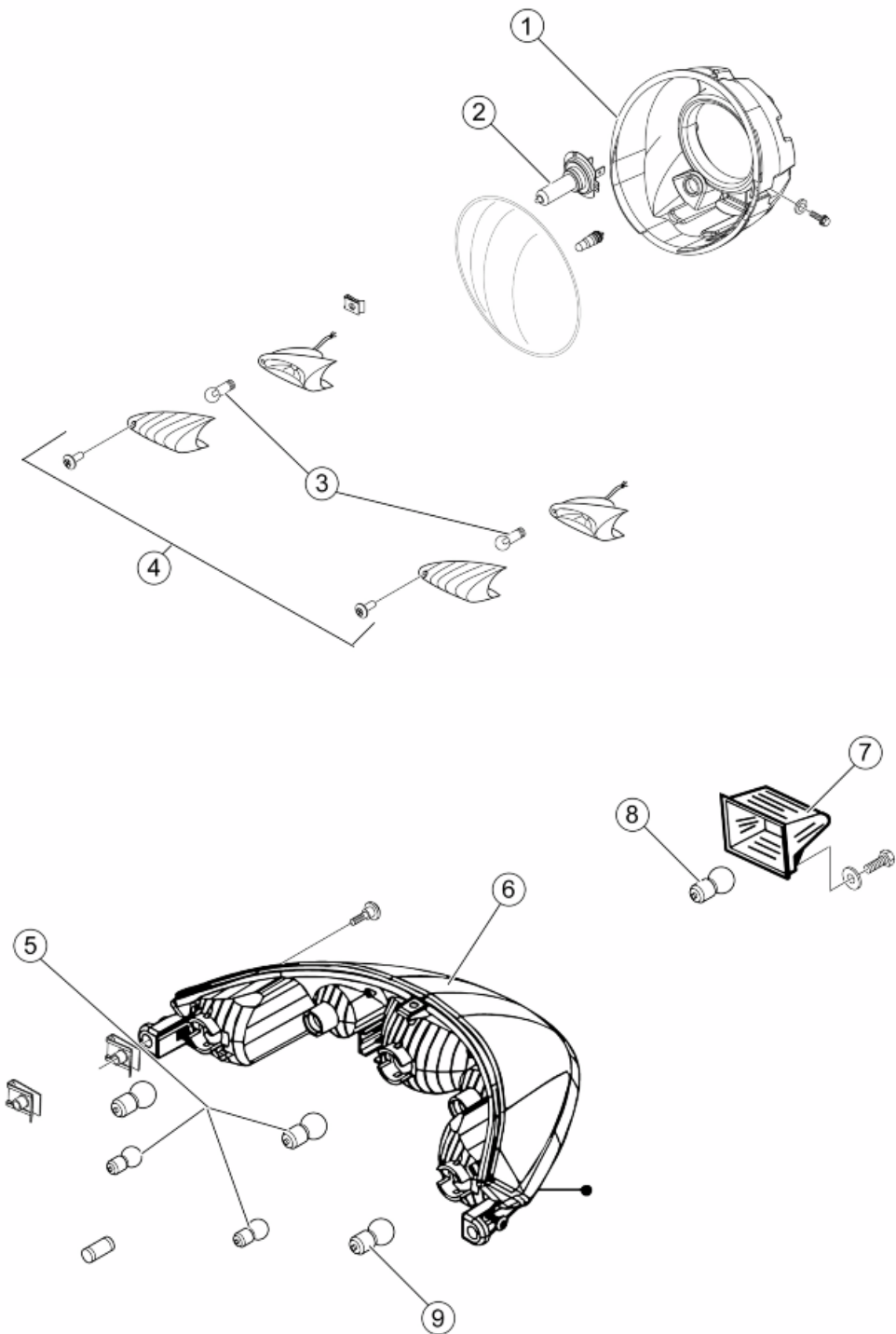

**INDICATOR LIGHTS**

	Code	Action	Duration
1	005002	Front light - replacement	
2	005008	Headlight bulbs - Replacement	

	Code	Action	Duration
3	005067	Front turning indicator bulb - replacement	
4	005012	Front turning indicators - Replacement	
5	005066	Rear light bulbs - Replacement	
6	005005	Taillight - change	
7	005032	number plate light glass - Replacement	
8	005031	number plate light bulb - Replacement	
9	005068	Rear turning indicator bulb - Replacement	

**Front wheel**

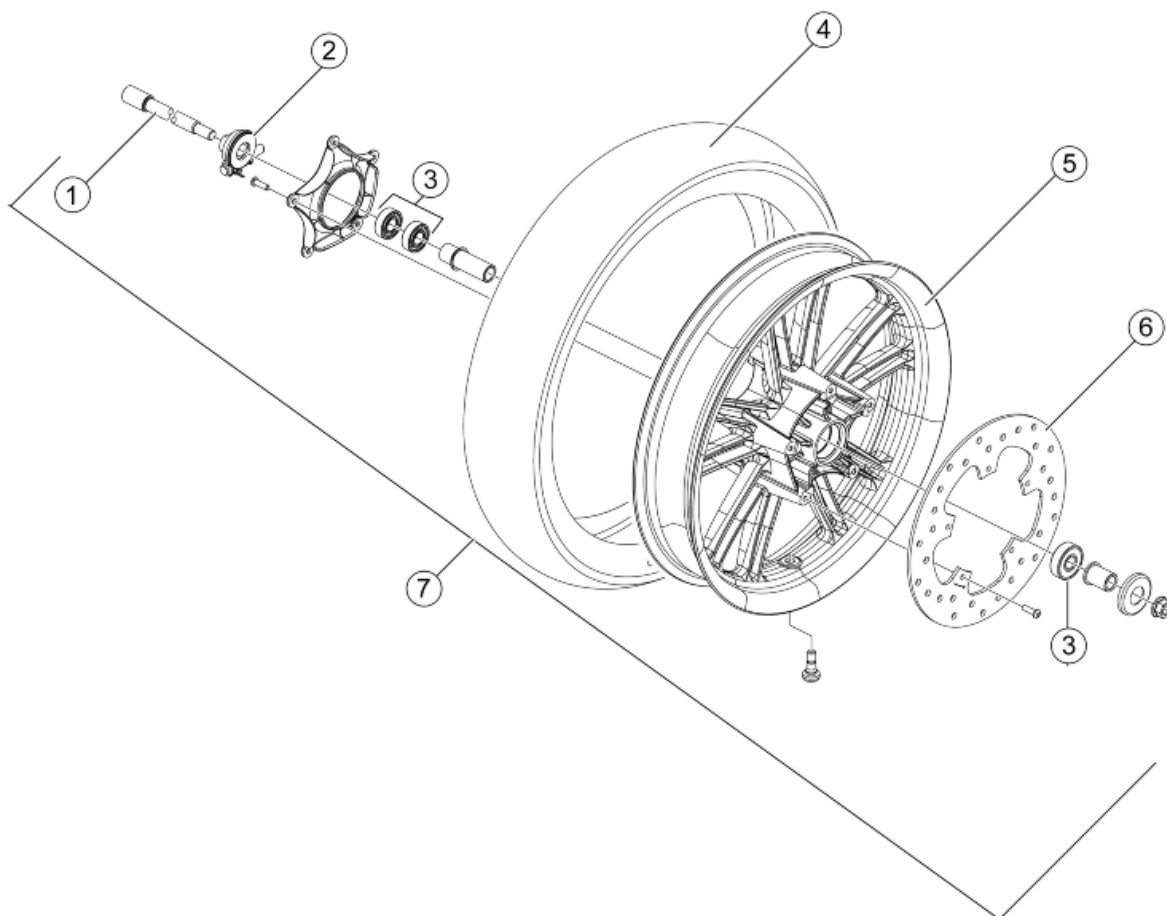

**FRONT WHEEL**

	Code	Action	Duration
1	003038	Front wheel axle - Replacement	
2	002011	Odometer drive - Replacement	
3	003040	Front wheel bearings - Replacement	
4	003047	Front tyre - Replacement	
5	003037	Front wheel rim - Replacement	
6	002041	Front brake disc - Replacement	
7	004123	Front wheel - Replacement	

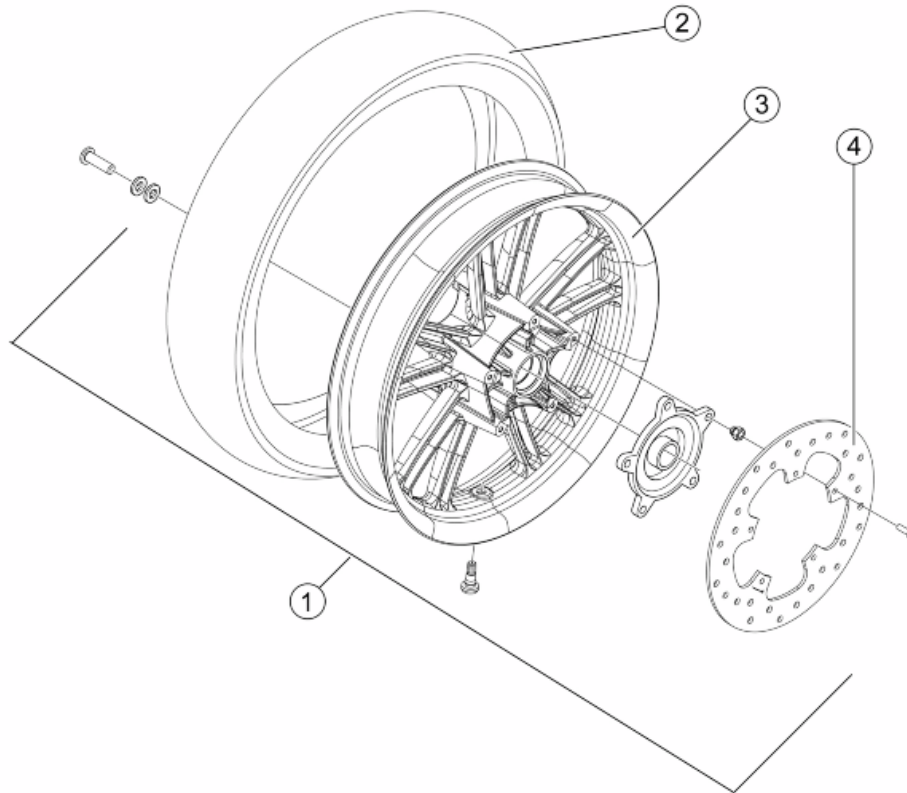
**Rear wheel****REAR WHEEL**

	<b>Code</b>	<b>Action</b>	<b>Duration</b>
1	001016	Rear wheel - Replacement	
2	004126	Rear wheel tyre - Replacement	
3	001071	Rear wheel rim - Replacement	
4	002070	Rear brake disc - Replacement	



## Electric devices

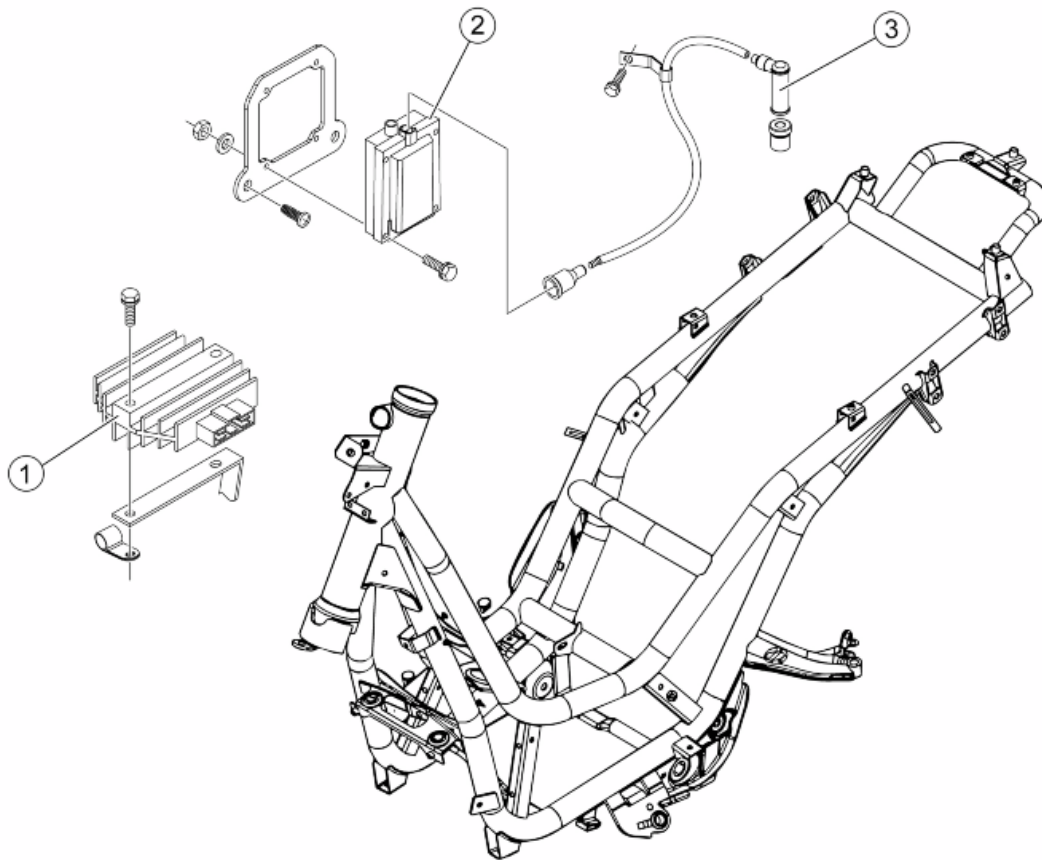

### VOLTAGE REGULATOR

	Code	Action	Duration
1	005009	Voltage regulator - Replacement	
2	001069	HV coil - Replacement	
3	001094	Spark plug cap - Replacement	



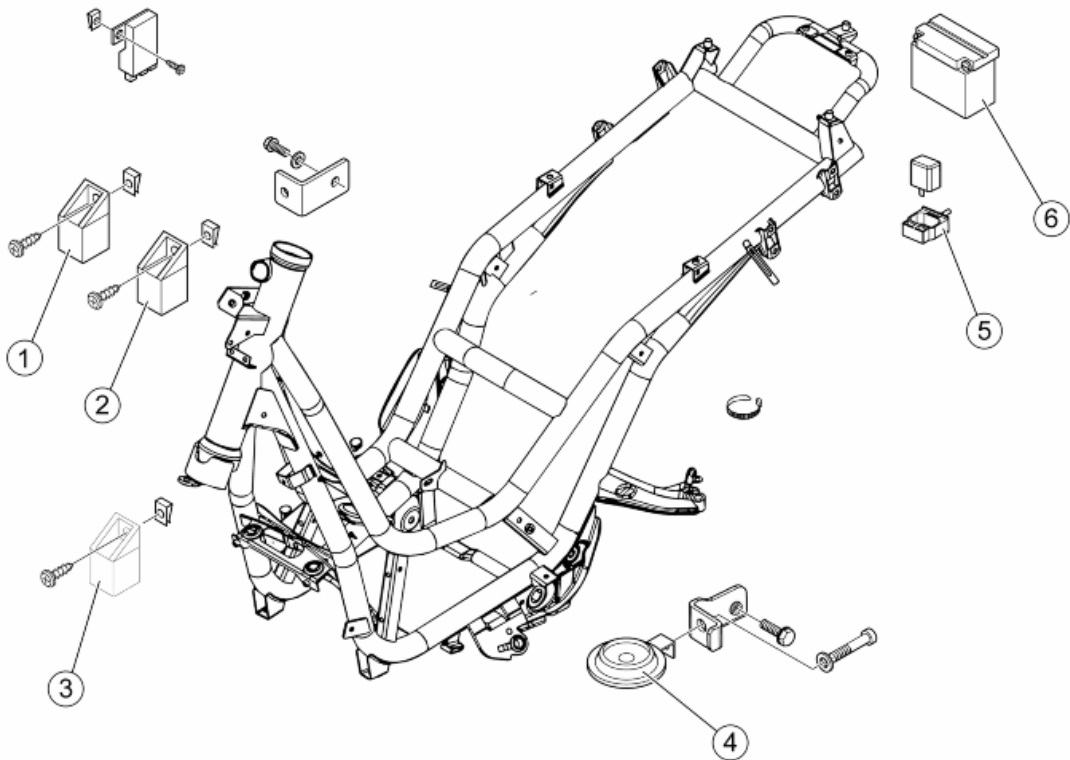

**CONTACTORS**

	<b>Code</b>	<b>Action</b>	<b>Duration</b>
1	005035	Headlight solenoid - Replacement	
2	005096	Injection Component contactor - Replacement	
3	005117	Electric fan contactor - Replacement	
4	005003	Horn - Replacement	
5	005011	Starter relay - Replacement	
6	005007	Battery - change	

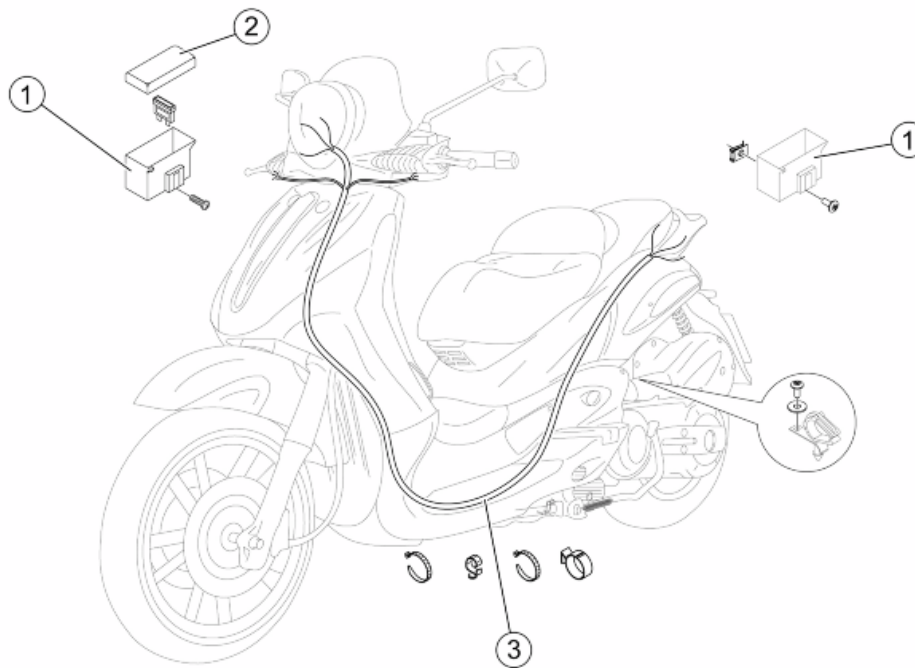

### WIRE UNIT

	<b>Code</b>	<b>Action</b>	<b>Duration</b>
1	005054	Fuse holder - Replacement	
2	005052	Fuse - Replacement	
3	005001	Electrical system - Replacement	

**Electronic controls**

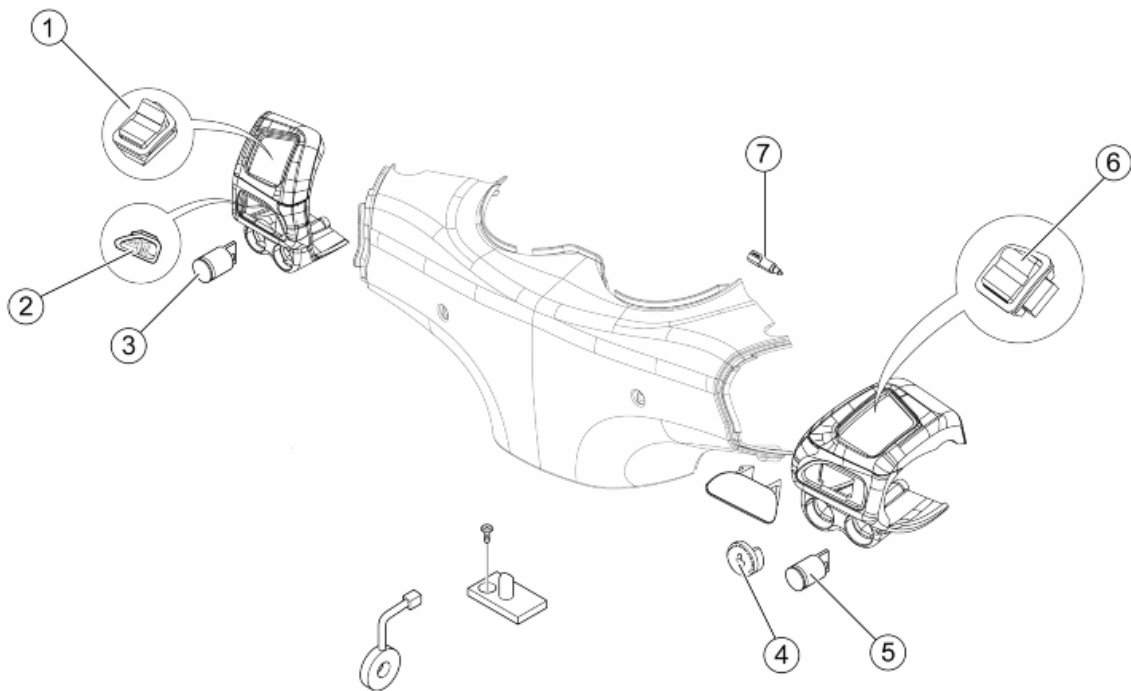

**ELECTRIC CONTROLS**

	<b>Code</b>	<b>Action</b>	<b>Duration</b>
1	005039	Lights switch - Replacement	
2	005006	Light or turning indicator switch - Replacement	
3	005040	Horn button - Replacement	
4	005121	Saddle opening button - Replacement	
5	005041	Starter button - Replacement	
6	005077	Emergency stop switch - Replacement	
7	005017	Stop switch - Replacement	

## Transmissions

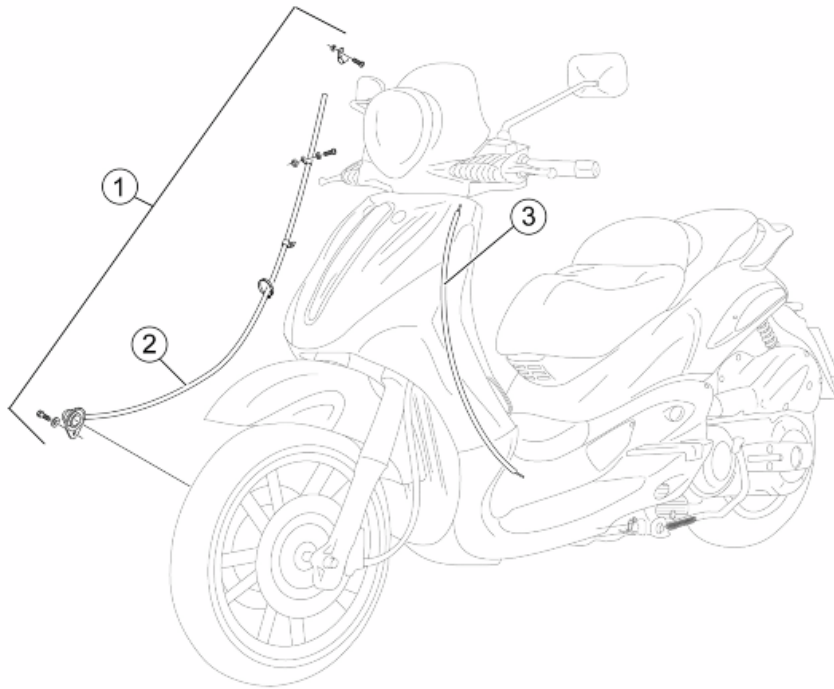

### TRANSMISSIONS

	<b>Code</b>	<b>Action</b>	<b>Duration</b>
1	002051	Odometer transmission assembly - Replacement	
2	002049	Odometer cable - Replacement	
3	002082	Fuel tank door opening drive - Replacement	

Front suspension

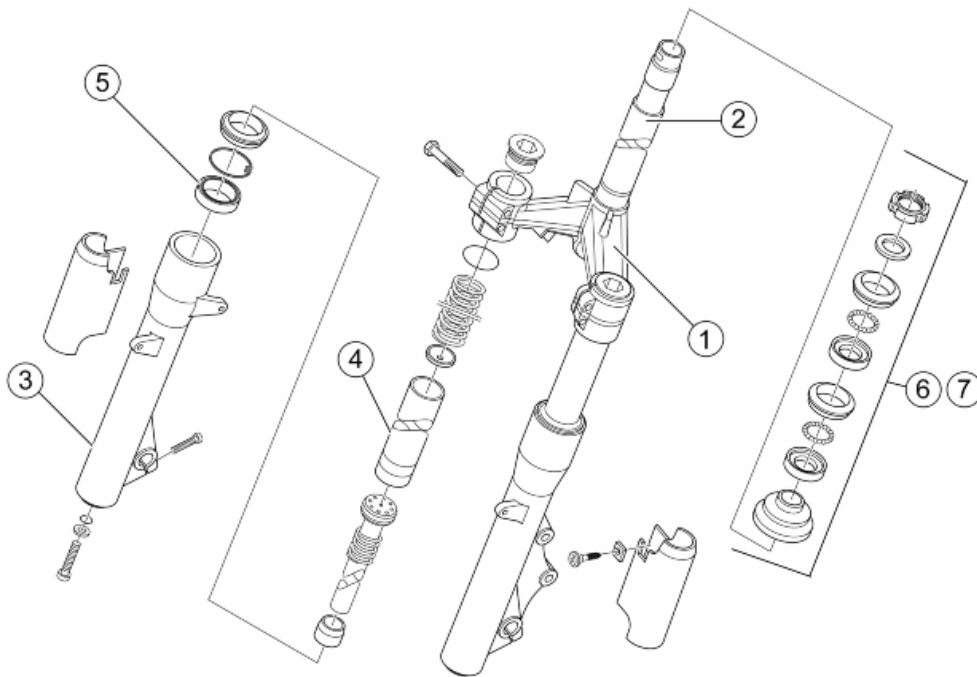

**FRONT SUSPENSION**

	Code	Action	Duration
1	003051	Complete fork - Replacement	
2	003010	Front suspension - Service	
3	003076	Fork sheath - Replacement	
4	003079	Fork stem - Replacement	
5	003048	Fork oil seal - Replacement	
6	003002	Steering fifth wheels - Replacement	
7	003073	Steering clearance - Adjustment	

## Cooling system

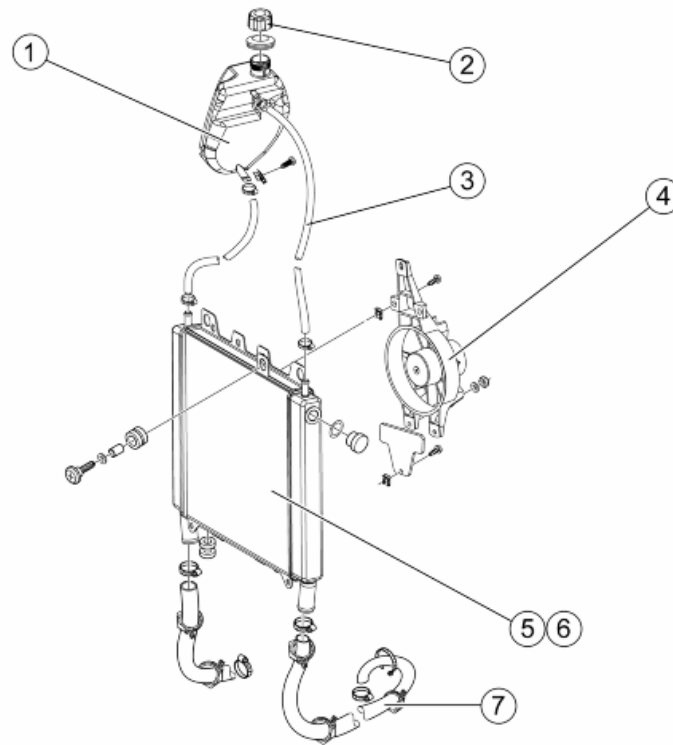

### RADIATOR

	Code	Action	Duration
1	007001	Expansion tank - Replacement	
2	007024	Expansion tank cap - Replacement	
3	007013	Radiator expansion tank connection pipe - change	
4	007016	Fan with support - Replacement	
5	001052	Coolant and air bleed - Replacement	
6	007003	Coolant delivery and return pipe - change	

**Windscreen**

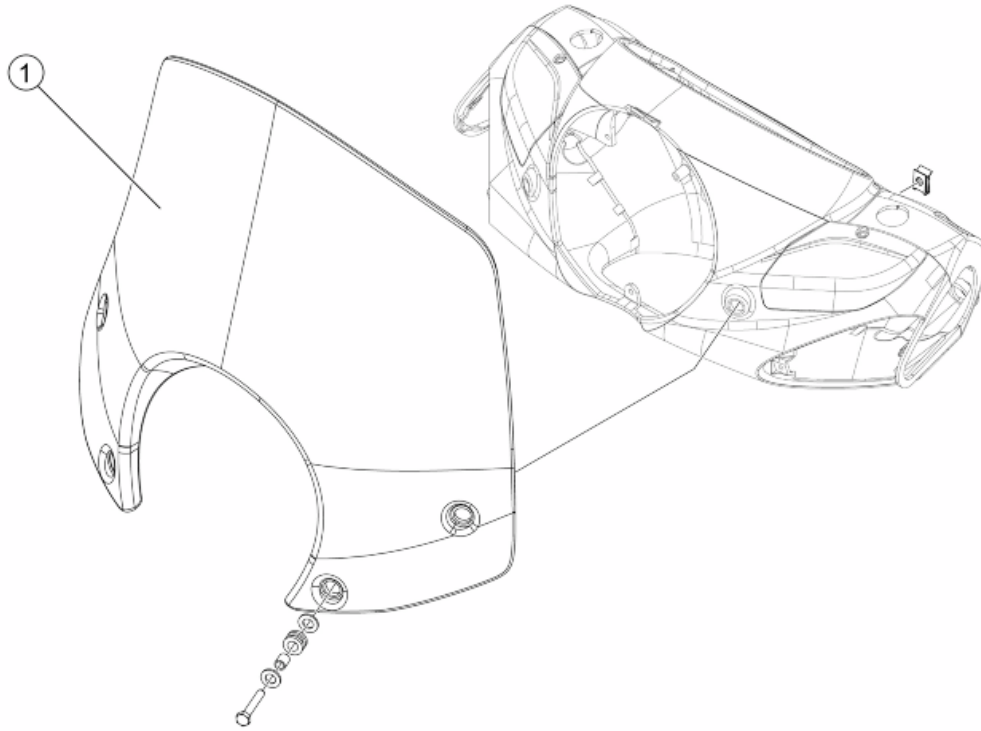

**WINDSCREEN**

	<b>Code</b>	<b>Action</b>	<b>Duration</b>
1	004028	Windshield glass - Replacement	

**Stickers**

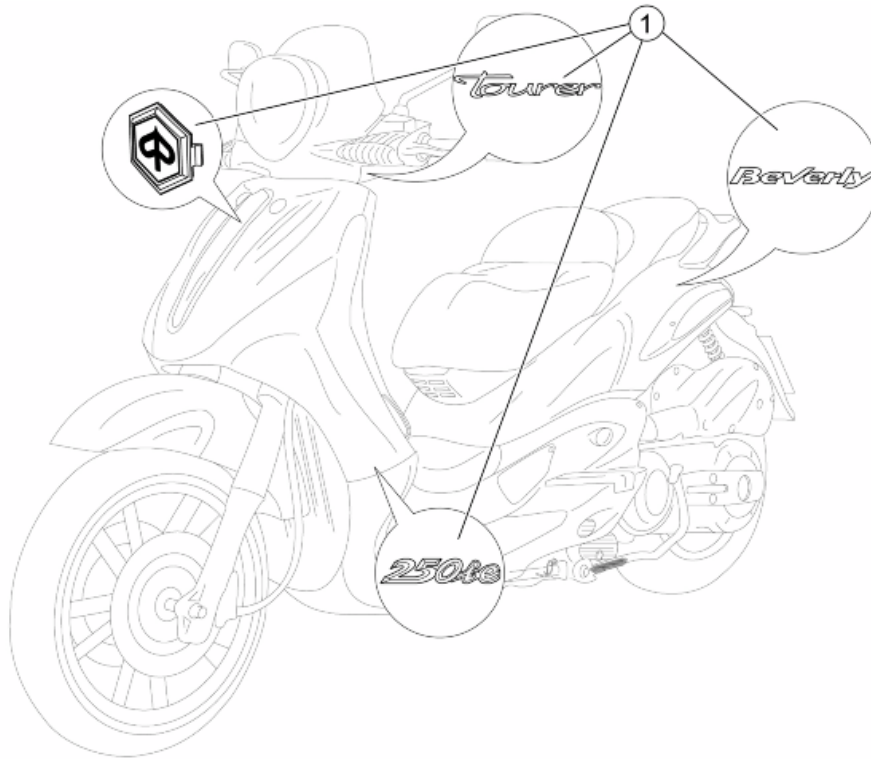

**TRANSFERS**

	<b>Code</b>	<b>Action</b>	<b>Duration</b>
1	004159	Plates / Stickers - Replacement	



## **A**

Air filter: 42

## **B**

Battery: 71, 81, 92, 93, 269

Brake: 233–235, 237–240, 242, 243, 311

Brake fluid: 242

Bulbs:

## **C**

Checks: 75

Coolant: 196

## **E**

Electric: 247, 320

Engine oil: 43

## **F**

Fuel: 176, 184, 306, 319

Fuses: 90

## **H**

Headlight: 50, 255

Horn: 87

Hub oil: 41

## **I**

Identification: 8

Instrument panel: 59, 255, 313

## **L**

Luggage rack:

## **M**

Maintenance: 7, 40

## **O**

Oil filter: 45, 284

## **R**

Recommended products:

## **S**

Saddle:

Shock absorbers: 226

Spark plug: 41, 80  
Stand: 231  
Start-up: 274  
Suspension: 54, 325

## **T**

Tank: 269, 306  
Transmission: 9, 53, 109, 123, 290  
Turn indicators: 74  
Tyres: 10

## **V**

Vehicle: 8, 102, 103