

PIAGGIO WOULD LIKE TO THANK YOU

for choosing one of its products. We have prepared this manual to help you to get the very best from your scooter. Please read it carefully before riding the scooter for the first time. It contains information, tips and precautions for using your scooter. It also describes features, details and devices to assure you that you have made the right choice. We believe that if you follow our suggestions, you will soon get to know your new vehicle and it will serve you well for a long time to come. This booklet forms an integral part of the scooter; should the scooter be sold, it must be transferred to the new owner.

Beverly Tourer 250ie



The instructions given in this manual are intended to provide a clear, simple guide to using your scooter; this booklet also details routine maintenance procedures and regular checks that should be carried out on the vehicle at an **authorised Dealer or Service Centre**. The booklet also contains instructions for simple repairs. Any operations not specifically described in this manual require the use of special tools and/or particular technical knowledge: to carry out these operations refer to any **authorised Dealer of Service Centres**.



Personal safety

Failure to completely observe these instructions will result in serious risk of personal injury.



Safeguarding the environment

Sections marked with this symbol indicate the correct use of the vehicle to prevent damaging the environment.



Vehicle intactness

The incomplete or non-observance of these regulations leads to the risk of serious damage to the vehicle and sometimes even the invalidity of the guarantee.

The signs that you see on this page are very important. They are used to highlight those parts of the booklet that should be read with particular care. As you can see, each sign consists of a different graphic symbol, making it quick and easy to locate the various topics.

INDEX

VEHICLE	7	Stand.....	30
Dashboard.....	9	Automatic transmission.....	31
Analogue instrument panel.....	11	Safe driving.....	32
Clock.....	12	MAINTENANCE	35
Key switch.....	12	Engine oil level.....	36
Locking the steering wheel.....	12	Engine oil level check.....	36
Releasing the steering wheel.....	12	Engine oil top-up.....	36
Switch direction indicators.....	13	Warning light (insufficient oil pressure).....	36
Horn button.....	13	Engine oil change.....	37
Light switch.....	13	Hub oil level.....	38
Start-up button.....	14	Tyres.....	40
Engine stop button.....	14	Spark plug dismantlement.....	42
The immobilizer system.....	14	Removing the air filter.....	43
Keys.....	14	Air filter cleaning.....	43
Immobilizerdevice enabled indicator led.....	15	Cooling fluid level.....	44
Operation.....	15	Checking the brake oil level.....	46
Programming the immobilizer system.....	16	Braking system fluid top up.....	46
Accessing the fuel tank.....	18	Battery.....	47
Power supply socket.....	18	Use of a new battery.....	48
The saddle.....	19	Long periods of inactivity.....	48
Opening the saddle.....	19	Fuses.....	49
Identification.....	20	Lamps.....	52
Rear top box opening.....	21	Front light group.....	54
Bag clip.....	22	Headlight adjustment.....	54
USE	23	Front direction indicators.....	56
Checks.....	24	Rear optical unit.....	56
Refuelling.....	24	Number plate light.....	58
Tyre pressure.....	25	Helmet compartment lighting bulb.....	58
Shock absorbers adjustment.....	27	Rear-view mirrors.....	59
Running in.....	28	Front and rear disc brake.....	59
Starting up the engine.....	28	Puncture.....	60
Stopping the engine.....	29	Periods of inactivity.....	61
anello antifurto.....	30	Cleaning the vehicle.....	61

Troubleshooting.....	62
TECHNICAL DATA.....	67
Kit equipment.....	72
SPARE PARTS AND ACCESSORIES.....	73
Warnings.....	74
PROGRAMMED MAINTENANCE.....	77
Scheduled maintenance table.....	78

Beverly Tourer 250ie



PIAGGIO®



**Chap. 01
Vehicle**

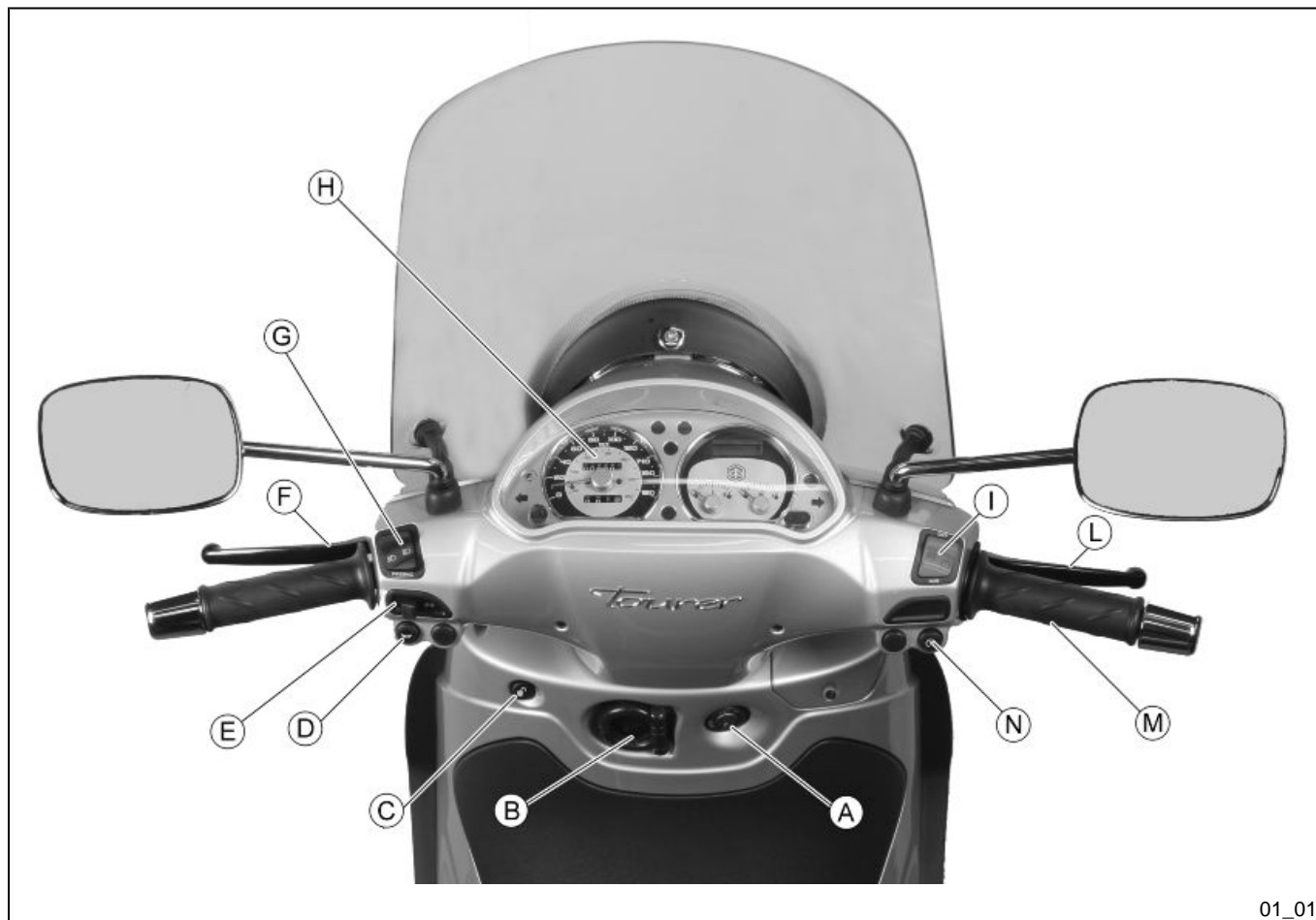

Dashboard (01_01)

A = Ignition key-switch

B = Bag hook

C = Saddle electric opening switch

D = Horn button

E = Turn indicator switch

F = Rear brake control lever

G = Light switch with passing

H = Instrument panel

I = Emergency cut-off switch RUN/OFF

L = Front brake lever

M = Throttle grip

N = Starter button

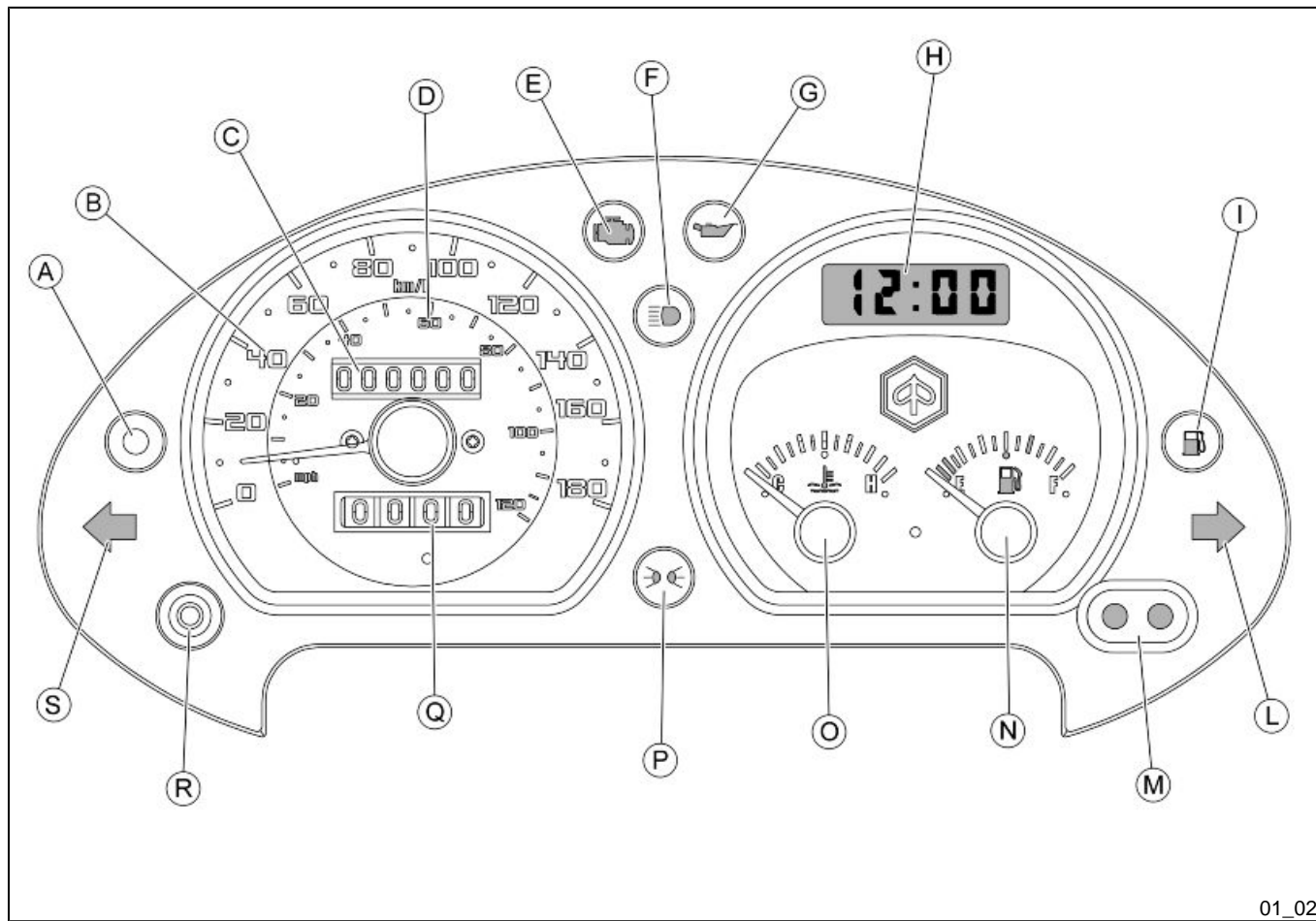

Analogue instrument panel (01_02)

A = Immobilizer LED

B = Speedometer (mph)

C = Total odometer

D = Speedometer (km/h)

E = Injection telltale light

F = High-beam warning light

G = Oil pressure warning light

H = Digital clock

I = Low fuel warning light

L = Right turn indicator warning light

M = Clock controls

N = Fuel gauge

O = Water temperature gauge

P = Headlight warning light

Q = Trip odometer

R = Odometer reset button

S = Left turn indicator warning light

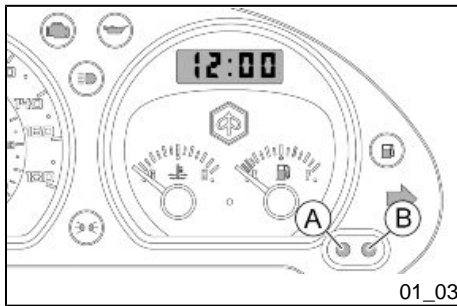

01_03

Clock (01_03)

Located in the instrument panel, it displays hours and minutes with 1 to 12 hour time, AM or PM.

Operate the function selection button «**B**» and month, day and seconds are also displayed besides hours and minutes.

To adjust the different functions, select the desired function with button «**A**» and adjust with button «**B**». The time counter can be reset by pressing button «**A**» with the clock in the seconds function.

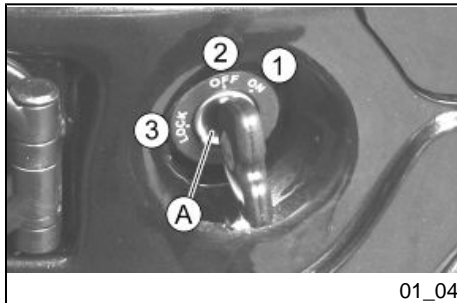

01_04

Key switch (01_04)

The key switch «**A**» is located on the front knee-guard panel near the bag hook.

SWITCH POSITIONS

ON «1»: Ready to start position, non-extractable key, mechanical antitheft device disabled.

OFF «2»: Ignition disabled, extractable key, mechanical antitheft device disabled.

LOCK «3»: Ignition disabled, extractable key, mechanical antitheft device enabled.

Locking the steering wheel

Turn the handlebar to the left as far as it will go, turn the key to position «**LOCK**» and remove the key.

Releasing the steering wheel

Reinsert the key and turn it to «**OFF**».

Switch direction indicators (01_05)

Move the switch «E» to the left to indicate a left turn; move the switch «E» to the right to indicate a right turn. Push the central part of the switch «E» to deactivate the turn indicators.

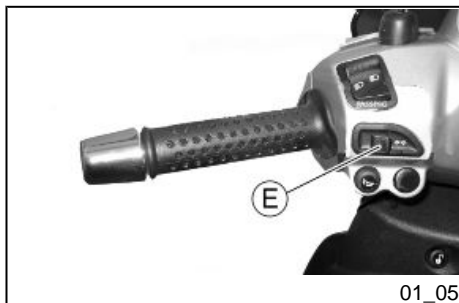

Horn button (01_06)

Push the button «D» to sound the horn.

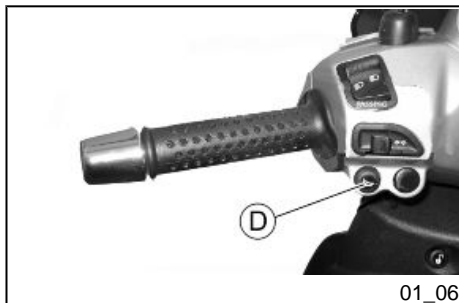

Light switch (01_07)

When the light switch «H» is set to «0», the low-beam light is on. When set to «1», the high-beam light is activated. If the light switch «H» is pressed when set to «2», the high-beam light flashing is activated. The switch goes back to «0» automatically.

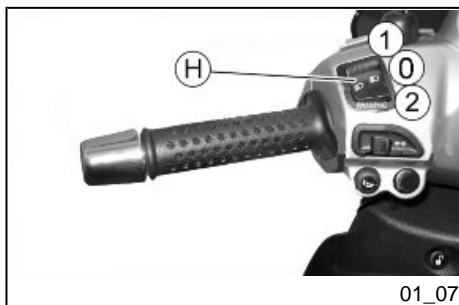

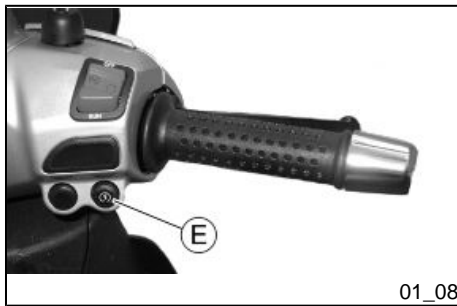

Start-up button (01_08)

Starter button «E»

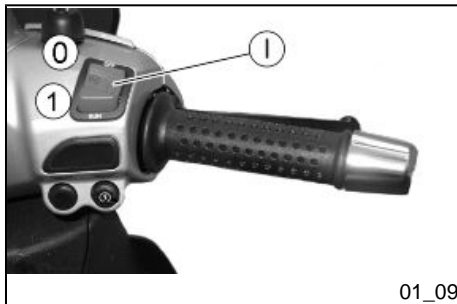

Engine stop button (01_09)

The engine can be started when the emergency cut-off switch «I» is set to «1» **RUN**; if the emergency cut-off switch «I» is set to «0» **OFF**, the engine cannot be started, or it shuts off if already running.

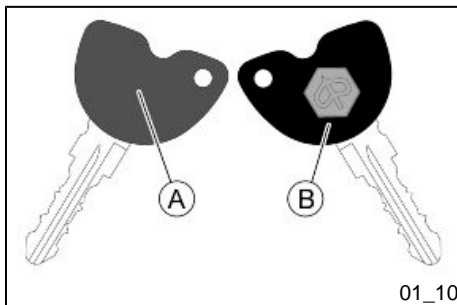

The immobilizer system

In order to enhance theft protection, the scooter is equipped with a «**PIAGGIO IMMOBILIZER**» electronic engine locking device that is activated automatically when the starter key is removed. Upon start-up, the «**PIAGGIO IMMOBILIZER**» system checks the starter key, and only if this key is recognised will the immobilizer system allow the scooter to be started.

Keys (01_10, 01_11, 01_12)

Two types of keys come with the vehicle.

The key «A» is the «**MASTER**» key.



01_11

Only a single copy of this key is supplied, which is necessary to program all your other keys and for your dealer to perform some maintenance operations. For this reason it is advised that it be used only in exceptional circumstances.

The key «**B**» (single copy supplied) is used for regular operations such as:

- Engine start-up.

Together with the two keys, you will be given a CODE CARD bearing the same code imprinted onto the two keys.

WARNING



LOSING THE MASTER KEY PREVENTS ANY FURTHER REPAIR OF THE "PIAGGIO IMMOBILIZER" SYSTEM AND OF THE ENGINE CONTROL UNIT.

WARNING



KEEP THE "CODE CARD" AND THE MASTER KEY IN A SAFE PLACE (NOT IN THE VEHICLE).

Immobilizer device enabled indicator led (01_13)

The activation of the «**PIAGGIO IMMOBILIZER**» system is signalled by a flashing indicator «**A**» .

In order to reduce battery discharge, the indicator LED turns off automatically after 48 hours of uninterrupted functioning.

Should the system fail, different LED flashing patterns will provide the **Authorised Service Centre** with information on the type of fault detected.

Operation

Each time the starter key «**B**» is removed while in the «**OFF**» or «**LOCK**» positions, the protection system activates the engine lock. Turning the starter key «**B**» to «**ON**»

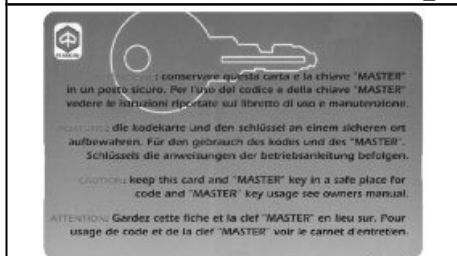

01_12

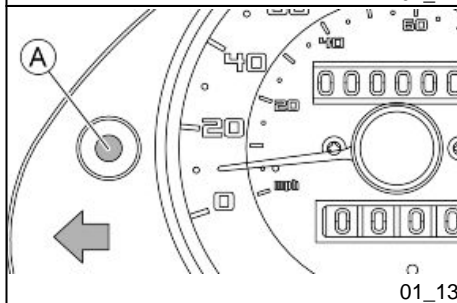

01_13

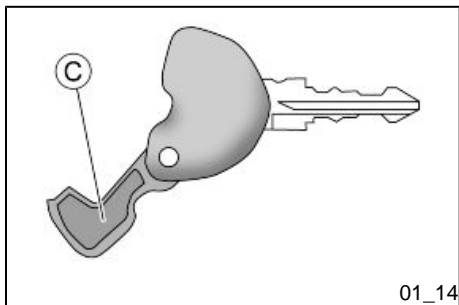

01_14

disables the engine lock, provided that the safety system recognises the code transmitted by the key. If the code is not recognised, turn the starter key «**B**» first to «**OFF**» and then back to «**ON**» again; if lock persists, try again using the «**A**» MASTER key. If the engine cannot be started, contact an **Authorised Service Centre**, which is provided with the electronic equipment required to detect and repair the system.

When the supplementary starter keys are required, remember that the all the keys, whether new or existing, should be programmed.

Contact an **Authorised Service Centre** and bring the «**A**» MASTER key and all «**B**» starter keys that you own.

The codes of starter keys not submitted for the new programming procedure are deleted from the memory. Any lost starter keys will therefore not be enabled to start the engine.

WARNING



EACH KEY HAS ITS OWN AND UNIQUE CODE, WHICH MUST BE STORED BY THE SYSTEM CONTROL UNIT.

VIOLENT SHOCKS MAY AFFECT THE ELECTRONIC COMPONENTS OF THE KEY.

IF THE VEHICLE IS SOLD, THE MASTER-HANDGRIP KEY (AS WELL AS THE OTHER STARTER KEYS) AND THE "CODE CARD" MUST ALSO BE TRANSFERRED TO THE NEW OWNER.

Programming the immobilizer system (01_14)

Below is described the procedure to follow for programming the **PIAGGIO IMMOBILIZER** system and/or for storing other key codes. The programming procedure should be carried out with the engine stop switch set to «**RUN**».

START PROCEDURE

Insert the «MASTER» key «**A**» into the key switch (in «**OFF**») and turn it to «**ON**». After 1 - 3 seconds, turn the key to «**OFF** » again and pull it out.

INTERMEDIATE STAGE

After extracting the «MASTER» key «**A**», insert, within ten seconds, the key that is going to be programmed «**B**» and turn it immediately to «**ON**». After 1-3 seconds, turn the key to «**OFF**» again and pull it out. In this way, a maximum of 7 keys can be programmed by repeating the above procedure and keeping the indicated times.

FINAL STAGE

After extracting the key to be programmed «**B**», insert the MASTER» key «**A**» again and turn it to «**ON**» (perform this operation within the 10 seconds following the extraction of the previous key). Leave it in this position for 1 to 3 seconds and return it to the «**OFF**» position.

CORRECT PROGRAMMING CHECK PHASE

Insert the «MASTER» key «**A**» disabling the transponder «**C**» (i.e., by tilting the key cap by 90°), and turn the key to «**ON**». Perform the engine start-up operation. Ensure that the engine does not start. Insert the programmed key «**B**» and repeat the start-up operation. Check that engine starts.

WARNING



SHOULD YOU STAR THE ENGINE WITH THE MASTER KEY (WITH TRANSPONDER OFF) OR IN THE EVENT OF WRONG OPERATION DURING PROGRAMMING, REPEAT THE PROCEDURE FROM THE BEGINNING.

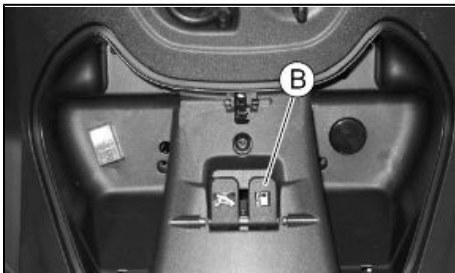

01_15



01_16

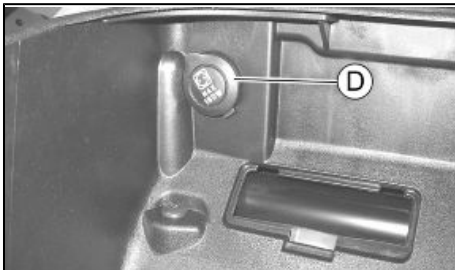

01_17

Accessing the fuel tank (01_15, 01_16)

Insert the key into the switch and press down until the glove box opens. In the event that the key switch is in «**LOCK**», turn the key to «**OFF**» or «**ON**» before pressing down. Press lever «**B**» and open the cover over the fuel tank cap «**C**».

Power supply socket (01_17)

There is a plug socket «**D**» inside the helmet compartment.

The plug socket may be used for external consumers (mobile phone, inspection light, etc.).

CAUTION



PROLONGED USE OF THE PLUG SOCKET MAY RESULT IN PARTIAL DISCHARGE OF THE BATTERY

Electric characteristic

Plug socket

12 V - 180 W MAX

The saddle (01_18, 01_19)

The saddle is supplied with a protection cover. Lift the saddle and extract the cover from its housing to use it.

Fit it over the seat without pulling excessively to avoid tearing the material; lower the saddle.

CAUTION



DO NOT USE THE VEHICLE WITHOUT THE PROTECTION COVER.

Opening the saddle (01_20, 01_21)

With the key in position «OFF» or «ON» or with the engine on, you can electrically open the saddle by pressing button «E». If the electric opening does not work, use the emergency lever «A».



01_18

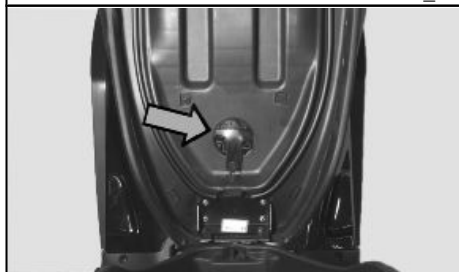

01_19

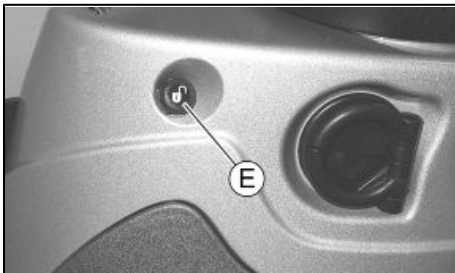

01_20

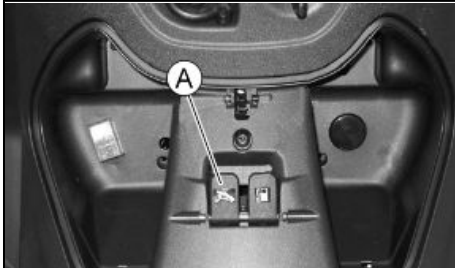

01_21

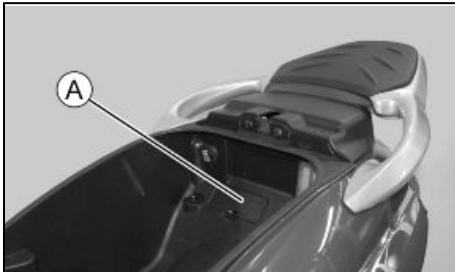

01_22

Identification (01_22, 01_23)

Identification registration numbers are made up of a prefix and a number stamped on the chassis and on the engine. These numbers must always be quoted when ordering spare parts. We recommend checking that the chassis registration number stamped on the vehicle corresponds with that on the vehicle documentation.

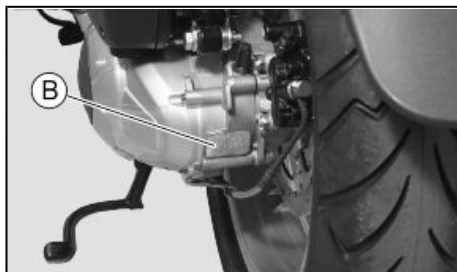

01_23

CAUTION

BE REMINDED THAT ALTERING IDENTIFICATION REGISTRATION NUMBERS CAN LEAD TO SERIOUS PENAL SANCTIONS (IMPOUNDING OF THE VEHICLE, ETC.).

Chassis number

To read the chassis number, remove the lid «A» in the helmet compartment.

Engine number

The engine number «B» is stamped near the rear left shock absorber lower support.

Rear top box opening (01_24)

Insert the key into the switch and press down until the glove compartment opens. In the event that the switch is in «LOCK», turn the key to «OFF» or «ON» before pressing it.

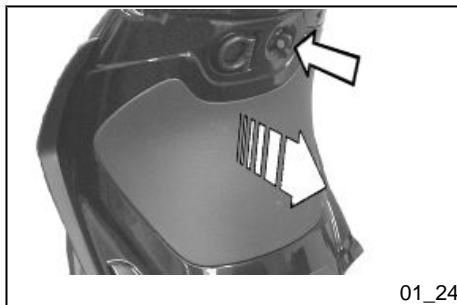

01_24

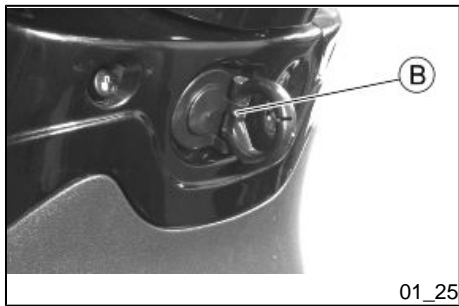

Bag clip (01_25)

To use the retractile bag hook «**B**» mounted on the knee-guard panel, pull it slightly towards the back part of the vehicle.

Beverly Tourer 250ie



PIAGGIO®



**Chap. 02
Use**

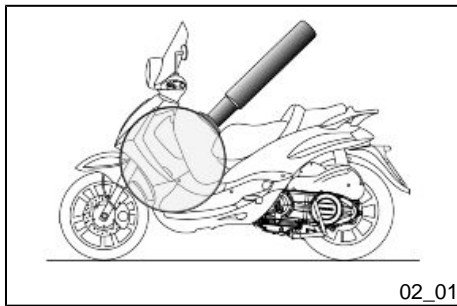

02_01

Checks (02_01)

Before using the vehicle, check:

1. There is enough fuel in the fuel tank.
2. Front and rear brake fluid level
3. That tyres are properly inflated.
4. The correct functioning of the tail lights, the headlight, and the turn indicators.
5. The correct functioning of front and rear brakes.
6. The oil level in the gearcase.
7. The engine oil level.
8. The coolant level

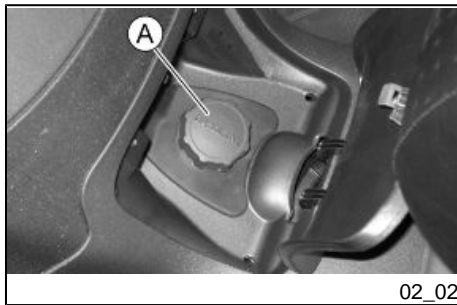

02_02

Refuelling (02_02)

Reach the fuel tank and unscrew the cap «A».

Use premium unleaded petrol, with minimum octane rating of 95.

A specific gauge on the instrument panel indicates the fuel level.

WARNING



SWITCH OFF THE ENGINE BEFORE REFUELLING WITH PETROL.

PETROL IS HIGHLY INFLAMMABLE.

DO NOT SMOKE AND KEEP OPEN FLAMES AT A DISTANCE: FIRE HAZARD.

DO NOT INHALE FUEL FUMES.

DO NOT ALLOW PETROL TO COME INTO CONTACT WITH HOT ENGINE OR ANY PLASTIC PARTS.

CAUTION

PETROL DAMAGES THE PLASTIC PARTS OF THE BODYWORK.

CAUTION

DO NOT USE THE VEHICLE TO THE COMPLETE EXHAUSTION OF THE FUEL; IN THE EVENT THAT THIS SHOULD OCCUR, DO NOT ATTEMPT TO START THE ENGINE. TURN THE KEY SWITCH TO OFF AND TOP-UP THE TANK AS SOON AS POSSIBLE. FAILURE TO FOLLOW THESE GUIDELINES COULD DAMAGE THE FUEL PUMP AND/OR THE CATALYTIC CONVERTER.

Characteristic**Fuel tank (reserve)**

~ 10 l (2 l)

Tyre pressure (02_03)

Check the tyre pressure and wear periodically (roughly every 500 km). Tyres feature wear indicators; replace tyres as soon as these indicators become visible on the tyre tread. Also check that the tyres do not show signs of splitting at the side or irregular tread wear; if this occurs, go to an authorised workshop or at least to a workshop equipped to perform the replacement.

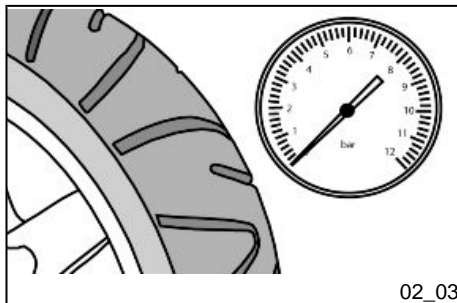

CAUTION



TYRE PRESSURE SHOULD BE CHECKED WHEN TYRES ARE COLD. INCORRECT TYRE PRESSURE CAUSES ABNORMAL TYRE WEAR AND MAKES RIDING DANGEROUS.

TYRES MUST BE REPLACED WHEN THE TREAD REACHES THE WEAR LIMITS SET FORTH BY LAW.

TYRES

Front tyre	Tubeless, 110/70 - 16" 52P
Rear tyre	Tubeless, 140/70 - 16" 65P

TYRE INFLATION PRESSURE

Front tyre pressure (with passenger)	2 bar (-)
Rear tyre pressure (with passenger)	2.5 bar (-)

Shock absorbers adjustment (02_04, 02_05)

The preloading of the springs can be adjusted to 4 positions using the ring nut located in the lower part of the shock absorbers and the specific spanner supplied.

Position 1: minimum preload: driver only

Position 2 medium preloading: driver only

Position 3 medium preloading: rider and passenger

Position 4: maximum preloading: driver, passenger, and luggage.

In order to carry out this operation you will need to use the specific spanner in the kit. Spring preloading increases by turning the ring nut towards «A», but decreases if the ring nut is turned towards «B».

CAUTION



RIDING THE VEHICLE WITH THE SPRING PRELOADING NOT CORRECTLY SET FOR THE RIDER AND POSSIBLE PASSENGER, COULD REDUCE THE COMFORT OF THE RIDE AND THE PRECISION OF THE STEERING.

WARNING



WE RECOMMEND WEARING GLOVES WHILE CARRYING OUT THIS OPERATION IN ORDER TO AVOID INJURIES.

WARNING



WE STRONGLY RECOMMEND NOT TO ADJUST BOTH SHOCK ABSORBERS WITH DIFFERENT PRELOADING

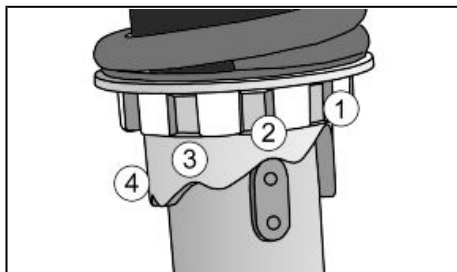

02_04

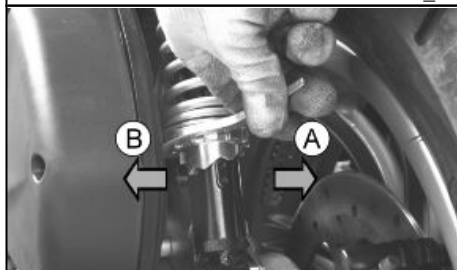

02_05

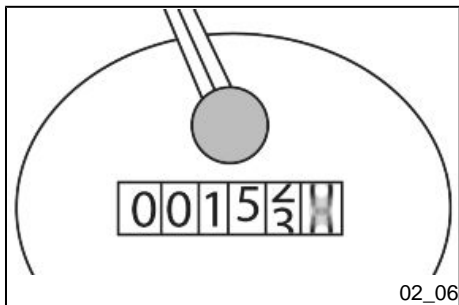

02_06

Running in (02_06)

DURING THE FIRST 1000 KM DO NOT RIDE THE VEHICLE OVER 80% OF ITS MAX. SPEED. AVOID OPENING THE THROTTLE GRIP COMPLETELY OR KEEPING A CONSTANT SPEED ALONG LONG SECTIONS OF ROAD. AFTER THE FIRST 1000 KM INCREASE SPEED PROGRESSIVELY, IF POSSIBLE, UNTIL THE MAXIMUM PERFORMANCE IS OBTAINED.

CAUTION



IN ORDER TO AVOID DAMAGING THE VEHICLE, PLEASE COMPLY WITH THE RULES LISTED ABOVE.

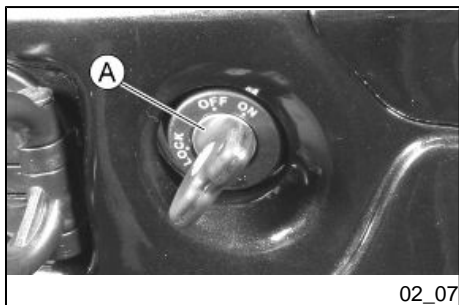

02_07

Starting up the engine (02_07, 02_08)

The vehicle is equipped with an ignition prevention system controlled by the side stand.

The engine cannot be started if the side stand is lowered.

If the engine is on, it will turn itself off if the side stand is lowered.

To start the engine it is necessary, before pressing the starter button, to pull and keep pulled the front or rear brake lever, which activates the appropriate switch allowing start-up.

1. Rest the vehicle on its centre-stand, ensuring the rear wheel is not touching the ground.
2. Keep the hand grip accelerator at the minimum.
3. Insert the key into the ignition switch «**A**» and turn to position «**ON**».
4. Make sure that the emergency stop switch «**B**» is in position «**RUN**» and the side stand is up and not engaged.
5. Pull lever «**C**» of the front or rear brake and then activate the starter button «**D**».

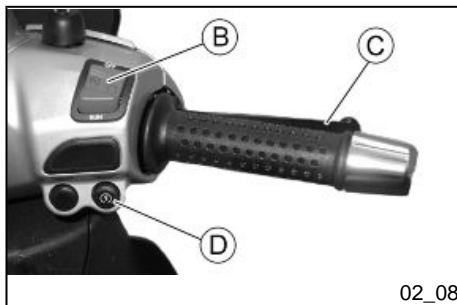
**WARNING**

THE AUTOMATIC TRANSMISSION MAKES THE REAR WHEEL TURN EVEN WHEN THE THROTTLE IS SLIGHTLY TWISTED. RELEASE THE BRAKE CAREFULLY AFTER STARTING, AND THEN ACCELERATE GRADUALLY.

CAUTION

DO NOT START-UP THE ENGINE IN CLOSED AREAS BECAUSE EXHAUST GASES ARE TOXIC.

Stopping the engine (02_09)

Fully untwist the throttle grip, then rotate the key in the switch «A » to «KEY OFF» (extractable key).

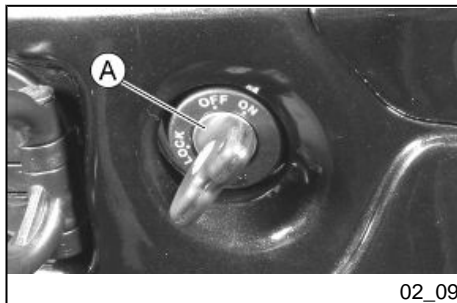

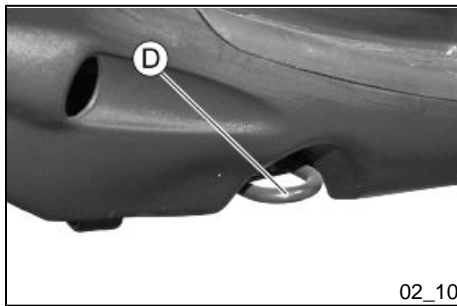

anello antifurto (02_10)

The «D» ring on the right side of the vehicle is used to fasten the vehicle to an object using a scooter chain. Do not use the ring for other purposes.

WARNING



THIS ACCESSORY IS NOT A THEFT PREVENTION GUARANTEE, IT IS ONLY A DETERRENT.

02_10

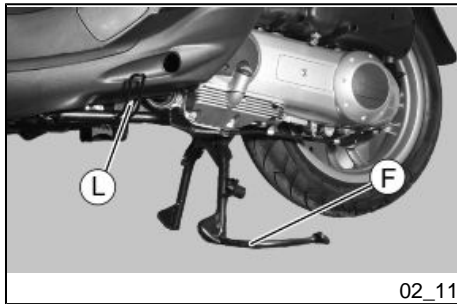

Stand (02_11)

Centre stand

Push with your foot on the centre stand's fork «F» while lifting the vehicle backward, holding onto the handlebar.

Side stand

Push with your foot on the stand's prong «L» until it releases into position, while lowering the vehicle onto the stand.

WARNING



THE SIDE STAND CAUSES THE ENGINE TO TURN ITSELF OFF WHENEVER IT IS LOWERED.

WARNING



TAMPERING MAY CAUSE SERIOUS ENGINE MALFUNCTION.

02_11

CAUTION



DUE TO THE HIGH TEMPERATURES THE CATALYTIC CONVERTER CAN REACH, ALWAYS TAKE CARE, WHEN PARKING THE SCOOTER, THAT THE EXHAUST DOES NOT COME INTO CONTACT WITH FLAMMABLE MATERIALS, TO AVOID SERIOUS BURNS.

CAUTION



DO NOT SWITCH OFF THE ENGINE WHILE THE VEHICLE IS MOVING. UN-BURNED FUEL COULD ENTER THE CATALYTIC CONVERTER AND BURN, CAUSING IT TO OVERHEAT AND POSSIBLY DESTROYING IT.

Automatic transmission (02_12)

To ensure simple, pleasurable riding, the vehicle is equipped with automatic transmission with regulator and centrifugal clutch. The system is designed to provide the best performance (acceleration and consumption) while riding on both flat roads and uphill.

If you have to stop on an uphill slope (traffic lights, traffic jam, etc.) **use only the brake to keep the vehicle still, leaving the engine running at idle speed. Using the engine to keep the vehicle still can cause the clutch to overheat, due to the friction of the clutch mechanism itself against the clutch bell.**

It is therefore recommended to avoid conditions of prolonged clutch slippage (other than those previously indicated) like driving uphill fully laden on steep slopes or starting off with driver and passenger at slopes with steepness greater than 25%.

Observe the following precautions if the clutch overheats:

1. Do not continue riding in such conditions.
2. Let the clutch cool down with the engine at idle speed for a few minutes.



02_12



Safe driving (02_13)

Some simple tips are provided below that will enable you to use your vehicle on a daily basis in greater safety and peace of mind. Your skill and your mechanical knowledge are the basis of safe riding. We recommend trying out the vehicle in traffic - free zones, in order to acquire a good knowledge of the vehicle itself.

1. Before riding off, remember to put on your helmet and fasten it correctly.
2. Reduce speed on rough roads and drive with care.
3. After riding on a long stretch of wet road without using the brakes, braking can be poor at the beginning. Given these conditions, it is a good idea to operate the brakes from time to time.
4. Do not brake hard on wet, dirt or slippery road surfaces.
5. Avoid riding off by mounting the scooter when resting on the support. In any case, the rear wheel should not be turning when it comes into contact with the ground, in order to avoid abrupt departures.
6. When riding along roads covered by sand, mud, snow mixed with salt, etc. we recommend cleaning the brake disc frequently with a non-corrosive detergent in order to prevent corrosive particles from building up in the holes, which may cause early brake pad wear.

CAUTION



ALWAYS RIDE WITHIN YOUR LIMITS RIDING UNDER THE INFLUENCE OF ALCOHOL OR OTHER DRUGS AND CERTAIN MEDICATIONS IS EXTREMELY DANGEROUS.

CAUTION



IN ORDER TO PREVENT ANY ACCIDENTS RIDE VERY CAREFULLY AFTER ADDING ACCESSORIES AND WHILE CARRYING LUGGAGE. ADDING ACCESSORIES

SORIES AND LUGGAGE CAN REDUCE THE VEHICLE'S STABILITY, PERFORMANCE AND SAFETY DURING USE.

WARNING



NEVER RIDE THE SCOOTER EQUIPPED WITH ACCESSORIES (TOP BOX AND/OR WINDSHIELD) AT A SPEED HIGHER THAN 100 km/h.

THE SCOOTER CAN BE RIDDEN AT A HIGHER SPEED WITHOUT THE ACCESSORIES MENTIONED BEFORE WITHIN THE LIMITS ESTABLISHED BY LAW.

IF THERE SHOULD BE NOT-PIAGGIO ACCESSORIES INSTALLED, OR AN ABNORMAL LOAD, OR IF THE SCOOTER IS NOT IN A GENERALLY GOOD CONDITION, OR WHENEVER WEATHER CONDITIONS DEMAND IT, SPEED SHOULD BE REDUCED FURTHER.

CAUTION



DO NOT ADJUST THE MIRRORS WHILE RIDING. THIS COULD CAUSE YOU TO LOOSE CONTROL OF THE VEHICLE.

CAUTION



ANY CHANGES TO THE VEHICLE PERFORMANCE AS WELL AS ALTERATIONS TO ORIGINAL STRUCTURAL PARTS IS STRICTLY FORBIDDEN BY LAW, AND RENDERS THE VEHICLE NO LONGER CONFORMING TO THE APPROVED TYPE AND DANGEROUS FOR RIDING.

Beverly Tourer 250ie



PIAGGIO®



**Chap. 03
Maintenance**



03_01

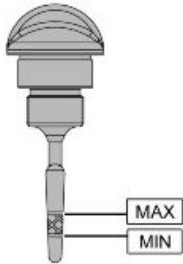

03_02

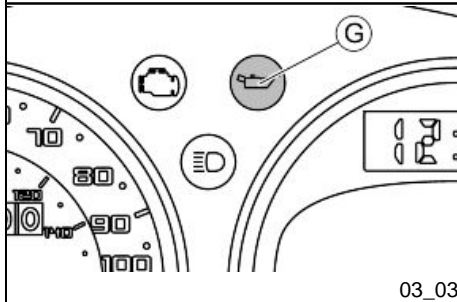

03_03

Engine oil level

In 4-stroke engines, engine oil is used to lubricate the distribution elements, the bushes and the thermal group. **An insufficient quantity of oil can cause serious damage to the engine.** In all four-stroke engines, a loss of efficiency in oil performance and consumption should be considered normal. Consumption can particularly reflect the conditions of use (i.e. when driving at "full acceleration" all the time, oil consumption increases). The replacement frequencies provided for by the maintenance programme are defined, depending on the total contents of oil in the engine and average consumption measured following standardised methods.

In order to prevent any problems, we recommend checking oil level more frequently than indicated in the Scheduled Maintenance table or before setting off on long journeys. The scooter is, however, equipped with an oil pressure warning light on the instrument panel.

Engine oil level check (03_01, 03_02)

Every time the vehicle is used, visually inspect the level of the engine oil when the engine is cold (after **completely unscrewing** the oil cap/dipstick). The oil level should be somewhere between the MAX and MIN reference marks on the dipstick «A»; during the oil check, the vehicle must be resting on its centre stand on an even, horizontal surface.

If the check is carried out after the vehicle has been used, and therefore with a hot engine, the level line will be lower; in order to carry out a correct check, wait at least 10 minutes after the engine has been stopped so as to get the correct level.

Engine oil top-up

Always check oil level before topping-up and add oil **without exceeding the MAX level**. Getting an oil level between the MIN and MAX levels requires ~ 200 cm³ of oil. Take your vehicle to an **Authorised Service Centre** to have the engine oil checked and if necessary, topped-up as indicated in the scheduled maintenance table.

Warning light (insufficient oil pressure) (03_03)

The scooter is equipped with a warning light «G» that lights up when the key is turned to «ON».

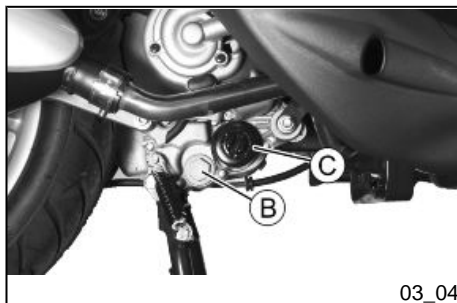

However, this light should switch off once the engine has been started.

If the light comes on during braking, at idling speed or while turning a corner, it is necessary to check the oil level and top-up if required. If after having topped-up the oil, the warning light still comes on while braking, at idle speed or while turning a corner, it will be necessary to take your vehicle to an Authorised Service Centre.

Engine oil change (03_04)

Have oil changed and the cartridge filter «C» replaced as indicated in the scheduled maintenance table at an **Authorised Service Centre**. The engine should be emptied by draining the oil from the drainage plug «B » of the gauze filter on the flywheel side. In order to facilitate the oil drainage, loosen the cap/dipstick. Since a certain quantity of oil still remains in the circuit, filling must be done with approx. 950 ÷ 1000 cm³ of oil through the cap «A. Then start up the engine, leave it running for a few minutes and shut it off: after five minutes, check the level and if necessary, top-up **without exceeding the MAX. level**. The cartridge filter must be replaced at every oil change. For top-ups and changes, use new oil of the recommended type.

WARNING



RUNNING THE ENGINE WITH INSUFFICIENT LUBRICATION OR WITH INADEQUATE LUBRICANTS ACCELERATES THE WEAR AND TEAR OF THE MOVING PARTS AND CAN CAUSE IRRETRIEVABLE DAMAGE.

WARNING



EXCESSIVE OIL LEVEL AT TOP-UPS CAN LEAD TO SCALE FORMATION AND VEHICLE MALFUNCTIONING.

CAUTION

USED OILS CONTAIN SUBSTANCES HARMFUL TO THE ENVIRONMENT. FOR OIL REPLACEMENT, CONTACT AN AUTHORISED PIAGGIO SERVICE CENTRE, AS THEY ARE EQUIPPED TO DISPOSE OF SPENT OILS IN AN ENVIRONMENTALLY FRIENDLY AND LEGAL WAY.

CAUTION

USING OILS OTHER THAN THOSE RECOMMENDED CAN SHORTEN THE LIFE OF THE ENGINE.

Recommended products**AGIP CITY HI TEC 4T**

Engine oil

SAE 5W-40, API SL, ACEA A3, JASO MA Synthetic oil

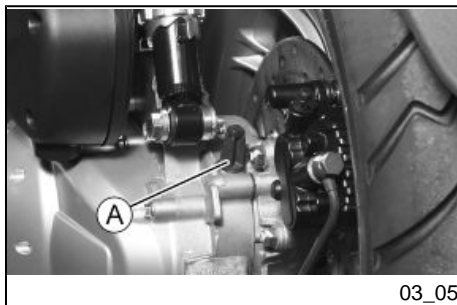
**Hub oil level (03_05, 03_06)**

Check the oil in the rear hub. To check the rear hub oil level, proceed as follows:

1. Rest the vehicle onto its centre stand, on level ground.
2. Unscrew the hub oil dipstick «A», dry it with a clean cloth. Reinsert it and **screw it fully into place**.
3. Pull out the dipstick to check that the hub oil level is slightly over the notch indicated by the arrow in the figure. This is the correct level and it must remain constant at all times.
4. Screw the dipstick back in, checking that it is locked in place.

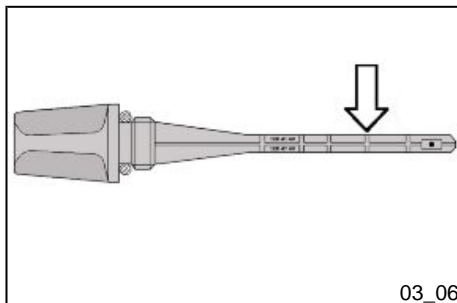
**N.B.**

The notches on the hub oil level dipstick, except for the one indicating the "MAX" level, refer to other models by the manufacturer and have no specific function for this model.

CAUTION

RIDING THE VEHICLE WITH INSUFFICIENT HUB LUBRICATION OR WITH CONTAMINATED OR IMPROPER LUBRICANTS ACCELERATES THE WEAR AND TEAR OF THE MOVING PARTS AND CAN CAUSE SERIOUS DAMAGE.

CAUTION

USED OIL CAN HARM THE ENVIRONMENT. COLLECTION AND DISPOSAL SHOULD BE CARRIED OUT IN COMPLIANCE WITH CURRENT REGULATIONS.

CAUTION

AN EXCESSIVE QUANTITY OF OIL CAN LEAD TO LEAKAGE, WHICH MAY CAUSE THE ENGINE AND THE WHEEL TO GET DIRTY.

CAUTION

WHEN REPLACING THE HUB OIL DO NOT LET THE OIL COME INTO CONTACT WITH THE REAR BRAKE DISC.

CAUTION

FOR OIL REPLACEMENT, CONTACT ANY AUTHORISED SERVICE CENTRE AS THEY ARE EQUIPPED TO DISPOSE OF USED OILS IN AN ENVIRONMENTALLY FRIENDLY AND LEGAL WAY.

Recommended products**AGIP ROTRA 80W-90***Rear hub oil*

SAE 80W/90 Oil that exceeds the requirements of API GL3 specifications

Characteristic**Transmission oil**

250 cm³

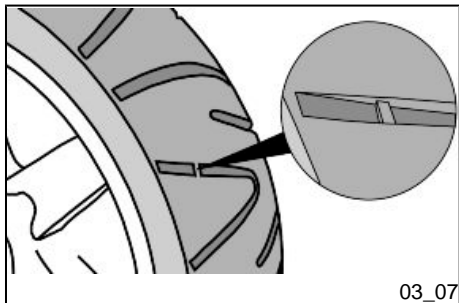
**Tyres (03_07)**

Check the tyre pressure and wear periodically (roughly every 500 km). Tyres feature wear indicators; replace tyres as soon as these indicators become visible on the tyre tread. Also check that the tyres do not show signs of splitting at the side or irregular tread wear; if this occurs, go to an authorised workshop or at least to a workshop equipped to perform the replacement.

CAUTION

TYRE PRESSURE SHOULD BE CHECKED WHEN TYRES ARE COLD. INCORRECT TYRE PRESSURE CAUSES ABNORMAL TYRE WEAR AND MAKES RIDING DANGEROUS.

TYRES MUST BE REPLACED WHEN THE TREAD REACHES THE WEAR LIMITS SET FORTH BY LAW.

WARNING



THE WHEELS FITTED WITH TYRES SHOULD ALWAYS BE BALANCED. RIDING THE VEHICLE WITH VERY LOW TYRE PRESSURE OR WITH INCORRECTLY BALANCED TYRES CAN LEAD TO DANGEROUS STEERING VIBRATIONS.

TYRES

Front tyre	Tubeless, 110/70 - 16" 52P
Rear tyre	Tubeless, 140/70 - 16" 65P

TYRE INFLATION PRESSURE

Front tyre pressure (with passenger)	2 bar (-)
Rear tyre pressure (with passenger)	2.5 bar (-)



03_08

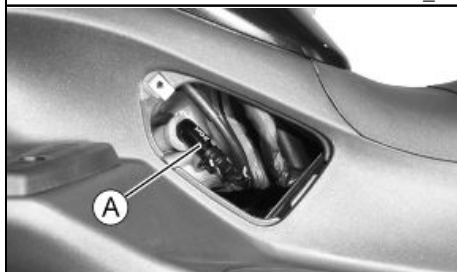

03_09

Spark plug dismantlement (03_08, 03_09)

Proceed as follows:

1. Remove the access cover over the spark plug on the right-hand side of the scooter and reach into the spark plug with your hand;
2. Disconnect spark plug HV wire cap «A» ;
3. Unscrew the spark plug using the spark plug wrench supplied;
4. When refitting, place the spark plug into the hole at the required angle and tighten by hand until it is finger tight;
5. Use the wrench only for final tightening of the spark plug;
6. Place hood "A" fully over the spark plug.

N.B.

THE USE OF SPARK PLUGS OTHER THAN THE INDICATED TYPE OR OF SHIELDLESS SPARK PLUG CAPS CAN CAUSE ELECTRICAL SYSTEM FAILURES.

WARNING



SPARK PLUGS MUST BE REMOVED WHEN THE ENGINE IS COLD. CHECK THE SPARK PLUG AS INDICATED IN THE SCHEDULED MAINTENANCE TABLE. USING NON-COMPLYING ELECTRONIC CENTRAL UNITS AND ELECTRONIC IGNITIONS OR SPARK PLUGS OTHER THAN THOSE PRESCRIBED MAY SERIOUSLY DAMAGE THE ENGINE. IF THE SPARK PLUG IS REMOVED AFTER A FLOODED ENGINE (EXCESSIVE FUEL EXPULSION IN THE «SAFE RIDING» SECTION), KEEP THE TUBE CONNECTED TO THE SPARK PLUG AND THE LATTER IN CONTACT WITH A GROUND POINT FAR FROM THE SPARK PLUG HOLE ITSELF IN ORDER TO AVOID THE EXPELLED FUEL FROM CATCHING FIRE.

Characteristic

Spark plug

CHAMPION RG 4 PHP

Electrode gap

0.7-0.8 mm

Removing the air filter (03_10, 03_11)

To access the air filter:

1. Lift the footrest mat and undo the three screws «A».
2. Remove the right footrest to have access to the nine screws «B» and unscrew them.
3. Remove the air filter cover «C».

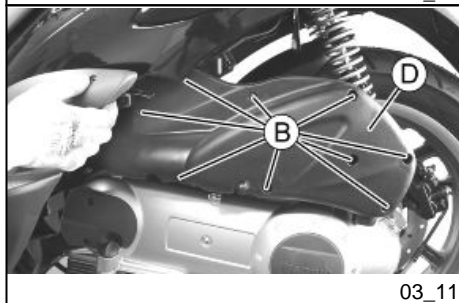
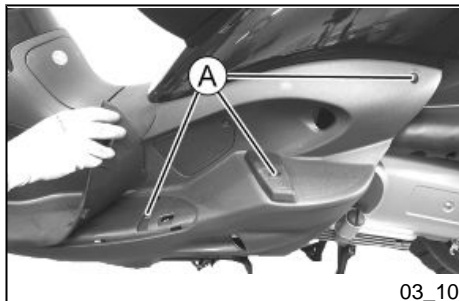

Air filter cleaning

1. Wash the sponge with water and neutral soap.
2. Dry it with a clean cloth and small blasts of compressed air.
3. Impregnate the sponge with a mixture of 50% petrol and 50% specified oil.

4. Gently squeeze the filter element, let it drip and then refit it.

CAUTION



IF THE VEHICLE IS USED ON DUSTY ROADS IT IS NECESSARY TO CARRY OUT MAINTENANCE CONTROLS OF THE AIR FILTER TO AVOID DAMAGING THE ENGINE.

Recommended products

AGIP FILTER OIL

Oil for air filter sponge

Mineral oil with specific additives for increased adhesiveness

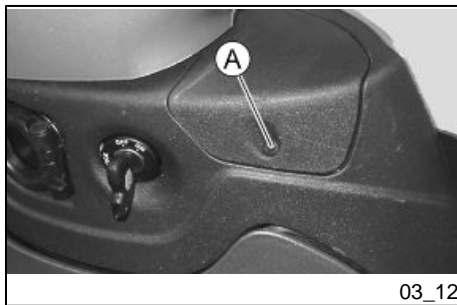

03_12

Cooling fluid level (03_12, 03_13, 03_14)

Engine cooling is carried out by a forced-circulation coolant system. The coolant consists of a mixture 50% de-ionised water and 50% glycol ethylene-based antifreeze solution with corrosion inhibitors. The coolant supplied with the scooter is already mixed and ready for use.

For proper engine functioning, make sure that the temperature of the coolant remains in the middle zone of the corresponding gauge. If the needle of the gauge enters the red zone, stop the engine, let it to cool down and check the coolant level; if the level is OK, contact an **Authorised Service Centre**.

Check coolant when the engine is cold and as indicated in the scheduled maintenance tables, following the steps below.

1. Set the vehicle upright on the stand and remove the cover by undoing screw «**A**».
2. Remove the expansion tank cover «**B**» by turning it anticlockwise.
3. Look inside the expansion tank and check that fluid level is always between the «**MIN**» and «**MAX**» levels.
4. Top-up the fluid when it is close to the minimum mark.

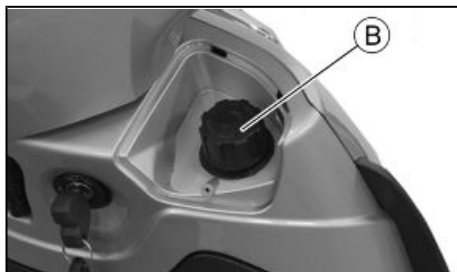

03_13

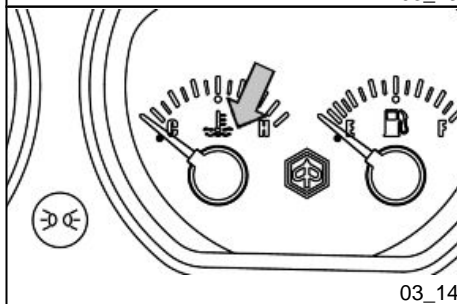

03_14

If the level is not correct, proceed to top-up when the engine is cold. If it is necessary to top up the coolant frequently, or if the expansion tank is completely dry, you should look for the cause in the cooling system. It is therefore essential to have the cooling system checked at an **Authorised Service Centre**.

Replace coolant as indicated in the scheduled maintenance table. Take your vehicle to an **Authorised Service Centre** for this operation.

WARNING



IN ORDER TO AVOID BURNS, DO NOT UNSCREW THE EXPANSION TANK CAP WHILE THE ENGINE IS STILL HOT.

WARNING



IN ORDER TO AVOID HARMFUL FLUID LEAKS WHILE RIDING, IT IS IMPORTANT TO MAKE SURE THAT THE LEVEL DOES NOT EXCEED THE REFERENCE TONGUE TOO MUCH.

IN ORDER TO GUARANTEE THE PROPER FUNCTION OF THE ENGINE, IT IS NECESSARY TO KEEP THE RADIATOR GRILLE CLEAN.

Recommended products

SPECIAL AGIP PERMANENT fluid

coolant

Monoethylene glycol-based antifreeze fluid, CUNA NC 956-16

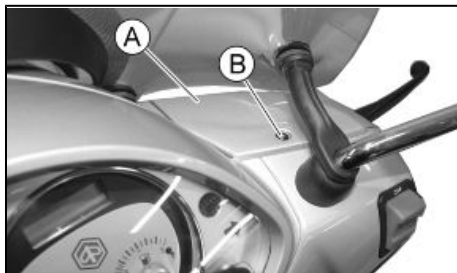

03_15

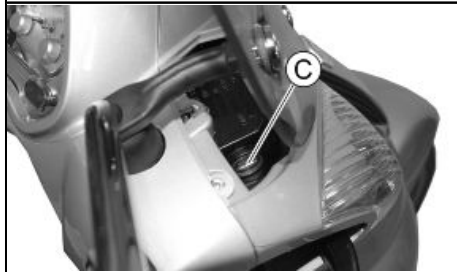

03_16

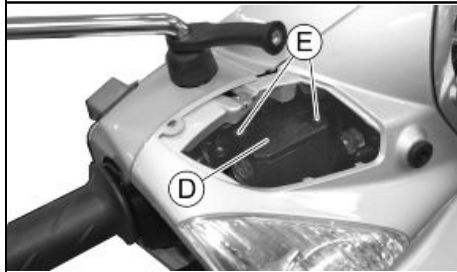

03_17

Checking the brake oil level (03_15)

The brake fluid tanks are located on the pumps under the front handlebar cover (front on the right-hand side, rear on the left-hand side).

The procedures to checking the brake fluid level for the front and rear brakes are identical.

Proceed as follows:

1. Place the scooter on its centre stand and make sure the handlebar is centred;
2. Loosen screw «A» and remove cover «B»;

3. Check the fluid level through the respective sight glass «C». A certain lowering of the level is caused by wear on the pads.

Should the level appear to be below the minimum mark, please contact an **Authorised Service Centre or Dealer** in order to have a thorough inspection of the braking system carried out.

Braking system fluid top up (03_16, 03_17)

Proceed as follows:

Remove tank cover «D» and loosen the two screws «E» and top-up the brake fluid level using only the prescribed brake fluid and without exceeding the maximum level.

Under standard climatic conditions, replace coolant as indicated in the scheduled maintenance table.

This operation must be carried out by trained technicians; take your scooter to an **authorised Service Centre or Dealer**.

WARNING

BRAKE CIRCUIT FLUID IS VERY CORROSIVE; MAKE SURE THAT IT DOES NOT COME INTO CONTACT WITH THE PAINTWORK

CAUTION

ONLY USE DOT 4-CLASSIFIED BRAKE FLUID.

WARNING

THE BRAKE FLUID IS HAZARDOUS: IN CASE OF ACCIDENTAL CONTACT, WASH OFF WITH WATER.

WARNING

THE BRAKING CIRCUIT LIQUID IS HYGROSCOPIC, AND ABSORBS THE HUMIDITY OF SURROUNDING AIR. IF THE HUMIDITY IN THE BRAKING FLUID EXCEEDS A CERTAIN VALUE, IT WILL LEAD TO INEFFICIENT BRAKING. NEVER USE BRAKING FLUID KEPT IN CONTAINERS THAT HAVE ALREADY BEEN OPENED, OR PARTIALLY USED.

Recommended products**AGIP BRAKE 4**

Brake fluid
FMVSS DOT 4 Synthetic fluid

Battery (03_18, 03_19)

To access the battery, proceed as follows:

1. Place the scooter on its centre stand;
2. lift the saddle, paying attention to the points mentioned above.
3. remove the retainer «A» and the cover «B».
4. Release the elastic strap "C".

The battery is the electrical device that requires the most frequent inspections and diligent maintenance.

The main points of maintenance to be observed are as follows:

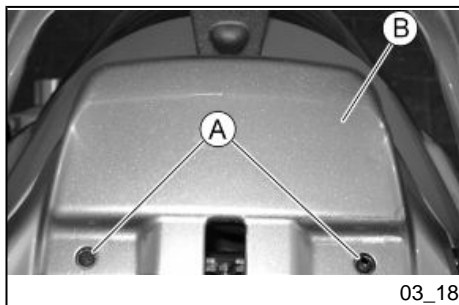

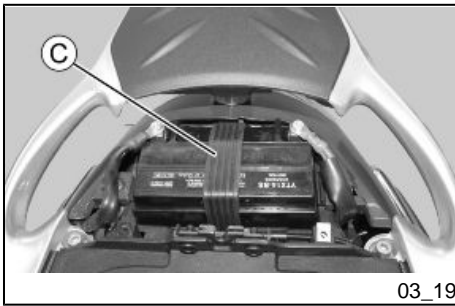
**WARNING**

DO NOT DISCONNECT THE BATTERY CABLES WITH THE ENGINE RUNNING, THIS CAN CAUSE PERMANENT DAMAGE TO THE VEHICLE ELECTRONIC CONTROL UNIT.

WARNING

SPENT BATTERIES ARE HARMFUL FOR THE ENVIRONMENT. COLLECTION AND DISPOSAL SHOULD BE CARRIED OUT IN COMPLIANCE WITH CURRENT REGULATIONS.

Characteristic**Battery**

12 V/12 Ah

Use of a new battery

Ensure that the terminals are connected correctly and check the voltage.

CAUTION

DO NOT REVERSE THE POLARITY: RISK OF SHORT CIRCUIT AND DAMAGE TO THE ELECTRICAL SYSTEM.

Long periods of inactivity

Battery performance will decrease if the vehicle is not used for a long time. This is the result of the natural phenomenon of battery discharging plus residual absorption by

vehicle components with constant power consumption. Poor battery performance may also be due to environmental conditions and the cleanness of the poles. In order to avoid difficult starts and/or irreversible damage to the battery, follow any of these steps:

- **At least once a month** start the engine and run it slightly above idle speed for 10-15 minutes. This keeps all the engine components, as well as the battery, in good working order.

- Take your vehicle to a garage (as indicated in the "Vehicle not used for extended periods" section) to have the battery removed. Have the battery cleaned, charged fully and stored in a dry, ventilated place. Recharge **at least once every two months**.

CAUTION

THE BATTERY MUST BE RECHARGED WITH A CURRENT LOAD EQUAL TO 1/10 OF THE BATTERY RATED CAPACITY AND FOR A PERIOD NOT LONGER THAN 8 HOURS. TAKE THE VEHICLE TO AN AUTHORISED PIAGGIO SERVICE CENTRE FOR THIS OPERATION. WHEN REFITTING THE BATTERY MAKE SURE THE LEADS ARE CORRECTLY CONNECTED TO THE TERMINALS.

Fuses (03_20, 03_21, 03_22, 03_23)

The electrical system is equipped with:

1. Six protective fuses «A» located inside the side panel on the right-hand side;
2. Four protective fuses «B» located inside the compartment on the upper left-hand side.

The chart shows the position and characteristics of the fuses in the vehicle.

CAUTION



BEFORE REPLACING THE BLOWN FUSE, FIND AND SOLVE THE FAILURE THAT CAUSED IT TO BLOW. NEVER TRY TO REPLACE THE FUSE WITH ANY OTHER MATERIAL (E.G., A PIECE OF ELECTRIC WIRE).

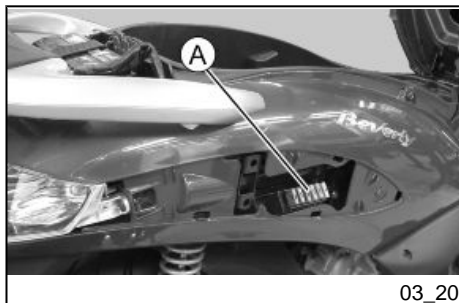

03_20

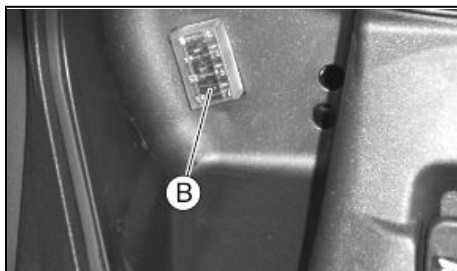

03_21

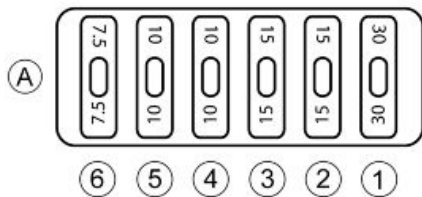

03_22

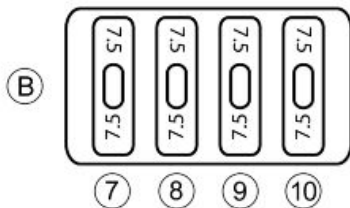

03_23

CAUTION

MODIFICATIONS OR REPAIRS TO THE ELECTRICAL SYSTEM, PERFORMED INCORRECTLY OR WITHOUT STRICT ATTENTION TO THE TECHNICAL SPECIFICATIONS OF THE SYSTEM, CAN CAUSE ERRORS IN FUNCTIONING AND RISK OF FIRE.

FUSES

Fuse No. 1	<p>Capacity:30 A</p> <p>Protected circuits:Battery recharge circuit.</p> <p>Live:Fuses No. 7-8-9-10.</p>
Fuse No. 2	<p>Capacity:5A</p> <p>Protected circuits:Clock, Immobilizer.</p>
Fuse No. 3	<p>Capacity:15A</p> <p>Protected circuits:Plug socket, helmet compartment light, electric fan (via remote control), pre-installation for anti-theft device.</p> <p>Live:Saddle opening actuator.</p>
Fuse No. 4	<p>Capacity:10 A</p> <p>Protected circuits:Injection load (via remote control).</p>
Fuse No. 5	<p>Capacity:15A</p> <p>Protected circuits:Light switch (via remote control).</p>
Fuse No. 6	<p>Capacity:7.5 A</p> <p>Protected circuits:Injection electronic control unit.</p>

Fuse No. 7	Capacity: 7.5 A Protected circuits: Headlight remote control, stop lights, start-up circuit.
Fuse No. 8	Capacity: 7.5 A Protected circuits: Tail lights, license plate light, panel lighting, horn.
Fuse No. 9	Capacity: 7.5 A Protected circuits: Electric fan remote control, injection load remote control, immobilizer aerial, injection electronic control unit.
Fuse No. 10	Capacity: 7.5 A Protected circuits: Pre-installation for anti-theft device, turn indicators, instrument panel.

Lamps

LIST OF BULBS

High-/low-beam bulb	Type: Halogen (H4) Quantity: 1 Power: 12V - 55/60W
---------------------	---

Front tail light bulb	Type: All glass Quantity: 1 Power: 12V - 5W
Turn indicator bulbs	Type: Spherical Quantity: 4 Power: 12V - 10W
Rear tail light bulb	Type: All glass Quantity: 2 Power: 12V - 3W
Stop light bulb	Type: Spherical Quantity: 1 Power: 12V - 10W
Instrument panel light bulbs	Type: All glass Quantity: 5 Power: 12V - 1.2W
Helmet compartment lighting bulb	Type: Cylindrical Quantity: 1 Power: 12V - 5W
License plate light bulb	Type: All glass Quantity: 1 Power: 12V - 5W

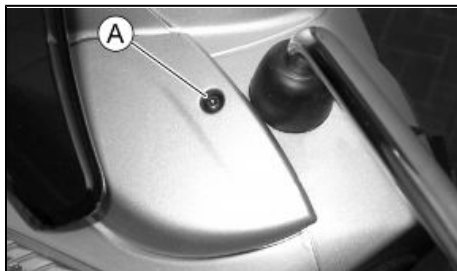

03_24

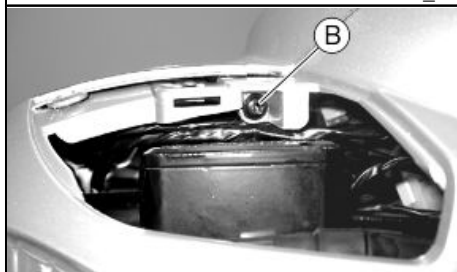

03_25

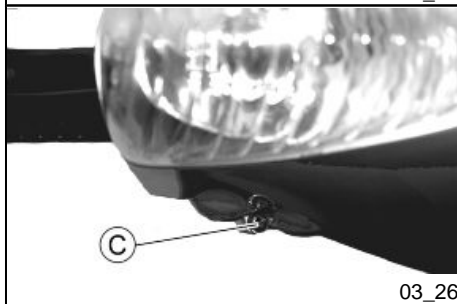

03_26

Front light group (03_24, 03_25, 03_26, 03_27, 03_28)

To remove the front headlight assembly, proceed as follows:

1. Remove screws «A» of the brake fluid tank cover.
2. Remove the 3 windshield screws and the windshield proper.
3. Remove the rear-view mirrors.
4. Remove the screws "C" of the upper coupling.
5. Remove the screws "C" of the lower coupling.
6. Remove the two screws "D" of the front handlebar cover.
7. Remove the front handlebar cover.

This gives access to the bulbs.

Release the spring and take out the bulb of the high-beam/low-beam headlamp «E».

To replace the tail light «F», pull out the rubber bulb holder from its seat.

To reassemble, repeat the operation in the reverse order.

WARNING



THE TWIN-FILAMENT (HIGH-BEAM AND LOW-BEAM) BULB IS HALOGEN: DO NOT TOUCH THE BULB WITH YOUR FINGERS TO AVOID COMPROMISING ITS FUNCTIONING

Headlight adjustment (03_29, 03_30)

Proceed as follows:

1. Place the vehicle in running order and with the tyres inflated to the prescribed pressure, on a flat surface 10 m away from a white screen situated in a shaded area, making sure that the longitudinal axis of the vehicle is perpendicular to the screen;

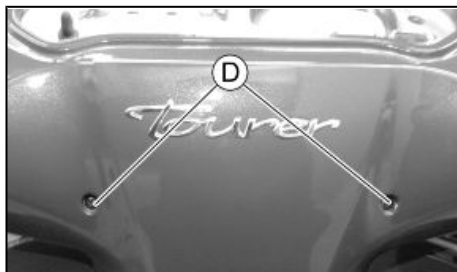

03_27

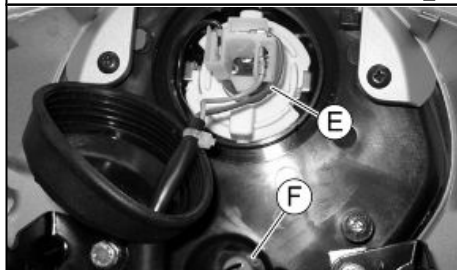

03_28

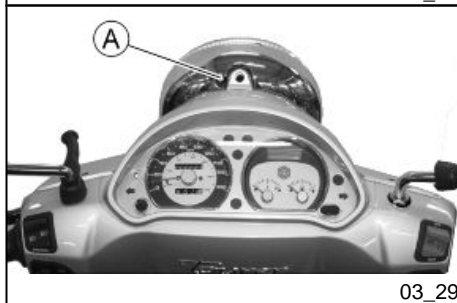

03_29

2. Turn on the headlight and check that the borderline of the projected light beam on the screen is not higher than 9/10 or lower than 7/10 of the distance from the ground to the centre of vehicle headlamp;

3. If this is not the case, regulate the headlight by turning screw «A».

N.B.

THE ABOVE PROCEDURE COMPLIES WITH THE EUROPEAN STANDARDS REGARDING MAXIMUM AND MINIMUM HEIGHT OF LIGHT BEAMS. REFER TO THE STATUTORY REGULATIONS IN FORCE IN EVERY COUNTRY WHERE THE vehicle IS USED.

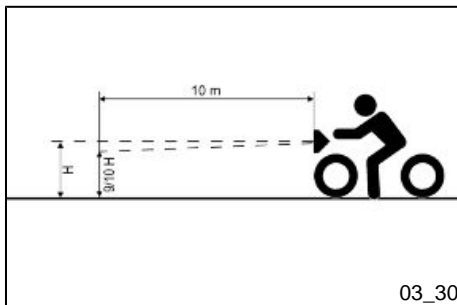

03_30

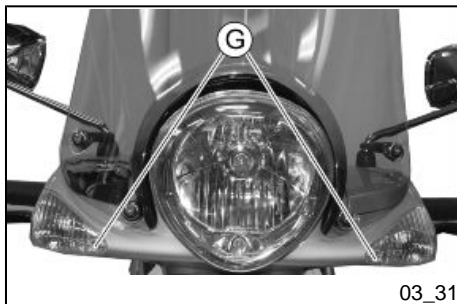

03_31

Front direction indicators (03_31)

To replace the burnt bulb, remove the screws «G»

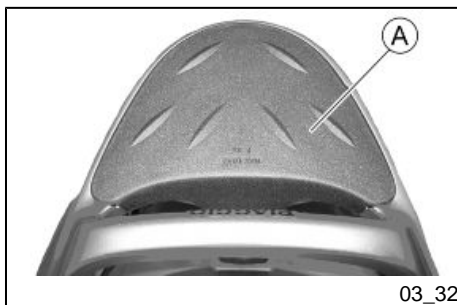

03_32

Rear optical unit (03_32, 03_33, 03_34, 03_35, 03_36)

To reach the rear light unit bulbs proceed as follows:

1. Remove the plastic cover «A» of the rear luggage rack.
2. Remove the screw «B».
3. Remove the screws «C» and the lateral panels of the fairings, paying attention not to damage the retaining straps.
4. Remove the two screws «D» of the light assembly being tested and remove it.

To replace the rear light bulb «E» release the clip and take out the bulb holder.

To replace the stop light bulbs «F» take out the rubber bulb holders and slide off the bulbs.

To replace the turn indicator bulbs «G» turn the bulb holder anticlockwise and extract it. Now hold the bulb, press and turn it clockwise and extract it.

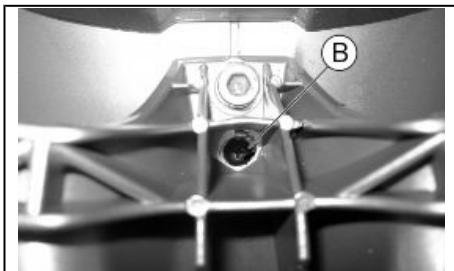

03_33



03_34

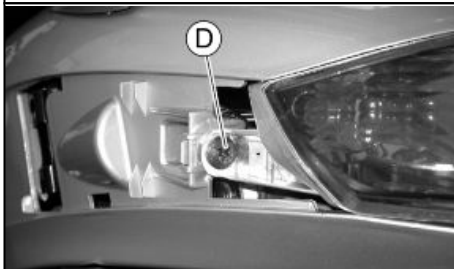

03_35

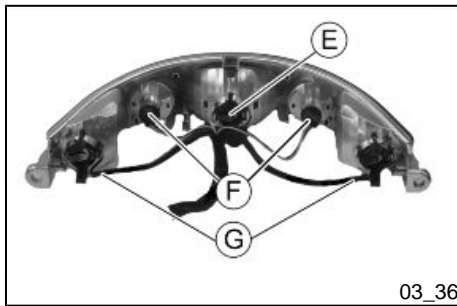

Number plate light (03_37)

Remove the screw «C», then take out the bulb holder.

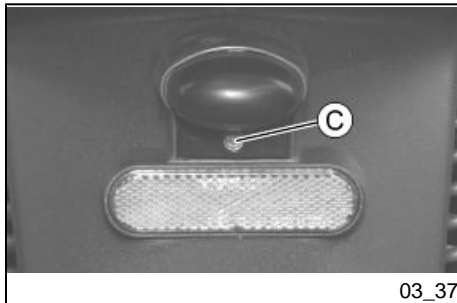

Helmet compartment lighting bulb (03_38)

Open the helmet compartment, take out the snap-on transparent glass and replace the bulb.

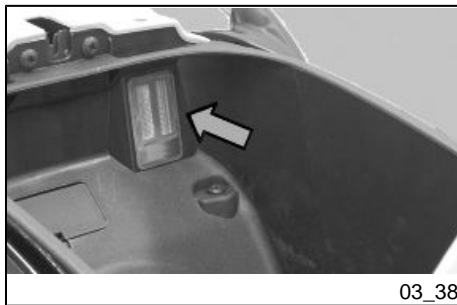

Rear-view mirrors

Adjust the mirrors by applying slight pressure to the side of the mirror to move it to the desired position.

Front and rear disc brake (03_39)

The brake disc and pad wear is automatically compensated, therefore it has no effect on the functioning of the front and rear brakes. For this reason it is not necessary to adjust the brakes. An excessively elastic brake lever stroke may indicate the presence of air in the braking circuit or a failure in the braking system. In this case, mainly due to the importance of brakes to guarantee safe riding conditions, the vehicle should be taken to an **Authorised Service Centre or Dealer**.

CAUTION



THE BRAKING ACTION SHOULD BEGIN AFTER ABOUT 1/3 OF THE BRAKE LEVER STROKE.

CAUTION



HAVE THE BRAKE PADS CHECKED BY THE DEALER ACCORDING TO THE CHECKS SPECIFIED IN THE SCHEDULED MAINTENANCE TABLE. HOWEVER, IN THE EVENT OF NOISES COMING FROM THE FRONT AND/OR REAR BRAKING SYSTEM DURING OPERATION, IT IS ADVISABLE TO HAVE THE BRAKING SYSTEM CHECKED BY AN AUTHORISED SERVICE CENTRE OR DEALER. AFTER REPLACING THE BRAKE PADS, DO NOT USE THE SCOOTER BEFORE HAVING USED THE BRAKE LEVER SEVERAL TIMES IN ORDER TO ALLOW THE PISTONS TO SETTLE AND THE LEVER STROKE TO BE SET TO THE CORRECT POSITION.



03_39

CAUTION

THE PRESENCE OF SAND, MUD, SNOW MIXED WITH SALT, ETC. ON THE ROAD, CAN DRASTICALLY REDUCE THE DURATION OF THE BRAKE PADS. IN ORDER TO AVOID THIS, WE RECOMMEND WASHING THE VEHICLE FREQUENTLY WHEN RIDING IN THESE ROAD CONDITIONS.

Puncture

The vehicle is equipped with tubeless tyres (without inner tube). In the event of a puncture, contrary to the situation with a tyre with inner tube, the tyre deflates more slowly, resulting in a greater steering safety. In the event of a puncture, it is admissible to make an emergency repair using an "inflate and repair" spray can. For a final repair, take your vehicle to an **Authorised Service Centre or Dealer**. The replacement of a tyre involves removing the wheel in question. Take your vehicle to an **Authorised Service Centre or Dealer** for these operations.

CAUTION

TO USE THE "INFLATE AND REPAIR" SPRAY PROPERLY FOLLOW THE INSTRUCTIONS ON THE PACKAGING.

WARNING

THE WHEELS FITTED WITH TYRES SHOULD ALWAYS BE BALANCED. RIDING THE VEHICLE WITH VERY LOW TYRE PRESSURE OR WITH INCORRECTLY BALANCED TYRES CAN LEAD TO DANGEROUS STEERING VIBRATIONS.



03_40

Periods of inactivity (03_40)

We recommend carrying out the following operations:

1. Clean the scooter thoroughly and then cover it with a canvas;
2. With the engine off and the piston in the bottom dead centre position, remove the spark plug, and pour into its hole 1 to 2 cc of the recommended oil. Operate the starter button 1-2 times for roughly 1 second to turn the engine over slowly, then insert the spark plug again;
3. Ensure that the **fuel tank is at least half full (in order to ensure the total immersion of the fuel pump)**; spread antirust grease on the unpainted metal parts; keep the wheels lifted above the ground by resting the chassis on two wooden wedges;
4. As regards the battery, follow the instructions in the "Battery" section.

Recommended products

AGIP CITY HI TEC 4T

Oil to lubricate flexible transmissions (throttle control)

Oil for 4-stroke engines

Cleaning the vehicle

Use a low pressure jet of water to soften the caked dirt and mud deposited on the painted surfaces. Once softened, sponge off mud and dirt using a car body sponge soaked in a car body shampoo and water solution (2-4% of car shampoo in water). Then rinse abundantly with water, and dry with a shammy cloth. For the outside of the engine, use petroleum, a brush and clean cloths. Petrol can damage paintwork. Remember that any polishing with silicone wax must always be preceded by washing.

CAUTION



DETERGENTS CAN POLLUTE WATER. THE VEHICLE MUST BE WASHED AT A WASH STATION EQUIPPED WITH A SPECIAL WATER PURIFICATION SYSTEM.

WARNING

THE USE OF A HIGH-PRESSURE WATER JET IS STRONGLY DISCOURAGED FOR ANY ENGINE CLEANING OPERATION; HOWEVER, IF NO OTHER MEANS ARE AVAILABLE, IT IS THEN NECESSARY TO:

- **ONLY USE THE FAN JET.**
- **DO NOT PLACE THE NOZZLE CLOSER THAN 60 CM.**
- **DO NOT USE WATER AT TEMPERATURES OVER 40°C.**
- **DO NOT USE HIGH-PRESSURE WATER JETS.**
- **DO NOT STEAM WASH.**
- **DO NOT DIRECT THE JET AT: THE CARBURETTOR, THE ELECTRIC CABLES, THE SLOT DIFFUSERS IN THE TRANSMISSION COVER AND THE SCROLL COVER.**

CAUTION

NEVER WASH THE SCOOTER IN DIRECT SUNLIGHT, ESPECIALLY IN SUMMER WHEN THE BODYWORK IS STILL HOT AS THE SHAMPOO COULD DAMAGE THE PAINTWORK IF IT DRIES BEFORE BEING RINSED OFF. NEVER USE CLOTHS SOAKED IN ALCOHOL, PETROL, DIESEL OIL OR KEROSENE FOR CLEANING THE PAINTED OR PLASTIC SURFACES, IN ORDER NOT TO DAMAGE THE LUSTRE FINISH OR ALTER THE MECHANICAL PROPERTIES. USING SILICONE-BASED WAX CAN DAMAGE THE PAINTED SURFACES, DEPENDING ON THE VEHICLE COLOUR (SATIN COLOURS). FOR FURTHER INFORMATION ON THIS MATTER, CONTACT AN AUTHORISED SERVICE CENTRE .

Troubleshooting

STARTING FAILURE

Emergency switch in «OFF»	Set the switch back to « ON »
Fuse blown	Replace the blown fuse and have the vehicle checked by an Authorised Service Centre .

STARTING DIFFICULTIES (SEE SECTION "DIFFICULT STARTING")

Lack of fuel in tank.	Refuelling
Injection system fault	Contact an Authorised Service Centre
Faulty fuel pump	Contact an Authorised Service Centre
Battery flat	Recharge the battery.

**** IMPORTANT: DO NOT USE THE SCOOTER TO THE COMPLETE EXHAUSTION OF THE FUEL; IN THE EVENT THAT THIS SHOULD OCCUR, DO NOT ATTEMPT TO START THE ENGINE. TURN THE KEY SWITCH TO "OFF" AND TOP-UP THE TANK AS SOON AS POSSIBLE. THE FAILURE TO FOLLOW THESE GUIDELINES COULD CAUSE DAMAGE TO THE FUEL PUMP AND/OR THE CATALYTIC CONVERTER.***

IGNITION PROBLEM

Faulty spark plug	Contact an Authorised Service Centre .
-------------------	---

Faulty ignition / injection control unit. Due to the presence of high voltage, this check should only be carried out by an expert.	Contact an Authorised Service Centre
--	---

LACK OF COMPRESSION

Loosen spark plug.	Screw in the spark plug tightly
Cylinder head loose, piston gas rings worn.	Contact an Authorised Service Centre.
Valve stuck	Contact an Authorised Service Centre.

HIGH CONSUMPTION AND LOW PERFORMANCE

Clogged or dirty air filter	Try to blow out with compressed air, otherwise replace the filter
-----------------------------	---

INSUFFICIENT BRAKING

Greasy disc. Worn pads. Faulty braking system. Presence of air in the front and rear brake circuit.	Contact an Authorised Service Centre.
---	--

INEFFICIENT SUSPENSIONS

Shock absorber fault, oil leak, end buffer damaged; shock absorber preloading incorrectly set	Contact an Authorised Service Centre.
---	--

IRREGULAR AUTOMATIC TRANSMISSION

Variator rollers and/or driving belt damaged

Contact an **Authorised Service Centre**.

Beverly Tourer 250ie



PIAGGIO®



**Chap. 04
Technical data**

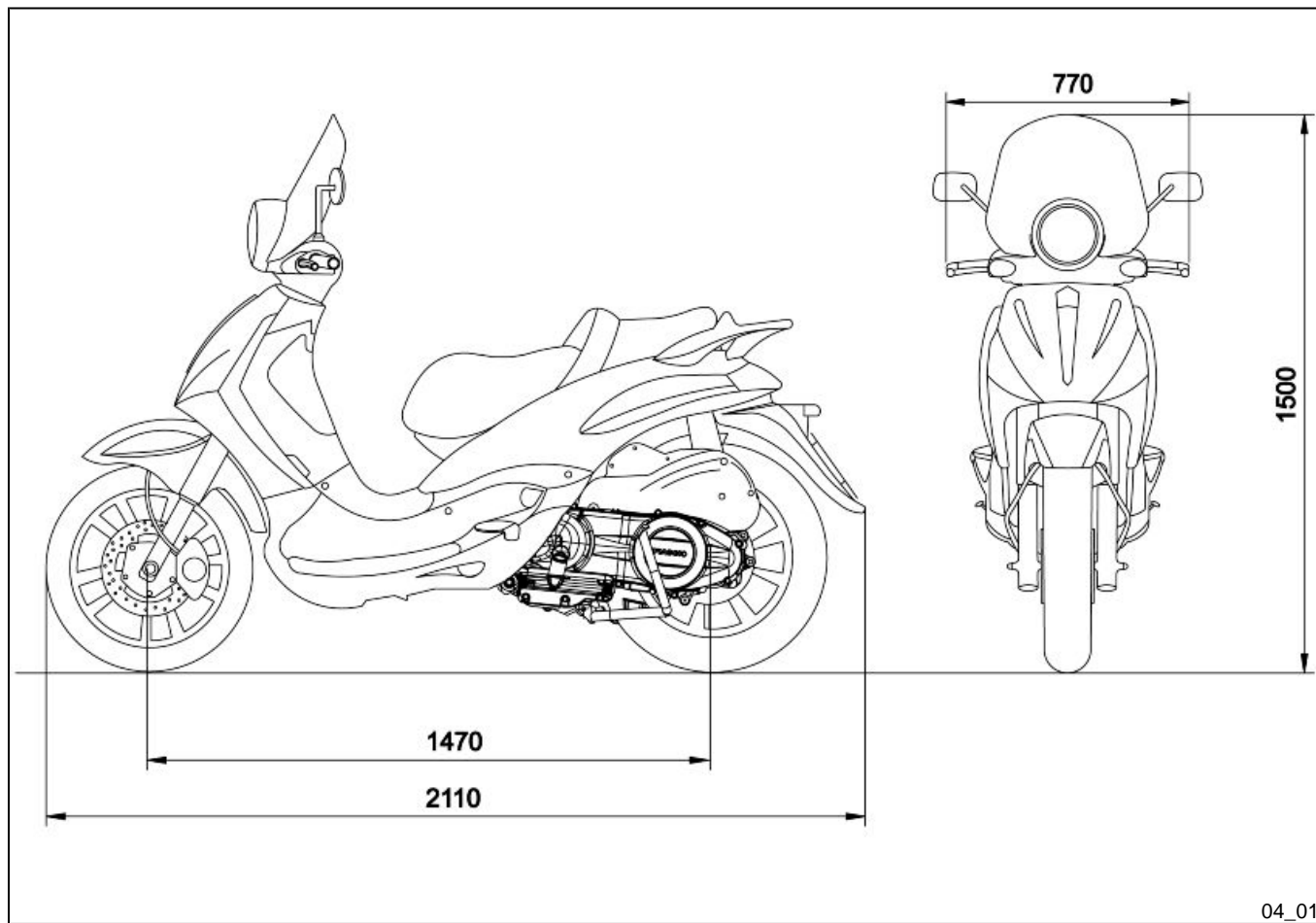

ENGINE TECHNICAL DATA

Type	Single-cylinder, 4-stroke
Cubic capacity	244 cm ³
Bore x Stroke	72 x 60 mm
Compression ratio	11 ± 0.5 : 1
Engine idle speed	1,700 ± 100 rpm
Timing system	4 valves, single overhead camshaft, chain-driven.
Valve clearance	Inlet: 0.10 mm Outlet: 0.15 mm
Max. power	16.5 KW at 8,000 rpm
MAX. torque	21 Nm at 6,250 rpm
Transmission	Automatic expandable pulley variator with torque server, V belt, dry self-ventilating automatic centrifugal clutch and transmission housing with forced air circulation.
Final reduction	Gear reduction unit in oil bath.
Lubrication	Engine lubrication with lobe pump (inside crankcase) controlled by a chain with double filter: mesh and paper.
Cooling	Forced coolant circulation system.
Start-up	Electric
Ignition	Electronic inductive discharge ignition, high efficiency, with separate HV coil.

Ignition advance	α /N three-dimensional map managed by control unit
Spark plug	CHAMPION RG 4 PHP
Alternative spark plug	-
Fuel supply	Electronic injection with \varnothing 32-mm throttle body and electric fuel pump.
Fuel	Unleaded petrol (95 RON)
Exhaust muffler	Absorption-type exhaust muffler with 3-way catalytic converter and lambda probe.
Emission regulations	EURO 3

VEHICLE TECHNICAL DATA

Chassis	Tubular and sheet steel.
Front suspension	Hydraulic telescopic fork with \varnothing 35 mm stem
Rear suspension	Two double-acting shock absorbers, adjustable to four positions at preloading.
Front brake	\varnothing 260 disc brake with hydraulic control activated by handlebar right lever.
Rear brake	\varnothing 260 mm disc brake with hydraulic control activated by handlebar left lever.
Wheel rim type	Light alloy rims.

Front rim	16" x 3.00
Rear rim	16 x 3.50"
Front tyre	Tubeless, 110/70 - 16" 52P
Rear tyre	Tubeless, 140/70 - 16" 65P
Front tyre pressure (with passenger)	2 bar (-)
Rear tyre pressure (with passenger)	2.5 bar (-)
Kerb weight	163 kg \pm 5 kg
Maximum weight allowed	350 kg
Battery	12V-12Ah

CAPACITY

Engine oil	1.3 l
Transmission oil	250 cm ³
Cooling system fluid	1.75 l
Fuel tank (reserve)	~ 10 l (2 l)

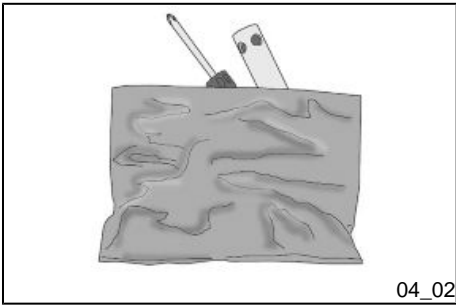

Kit equipment (04_02)

The tools are located under the saddle.

The tool kit includes:

- One box-spanner
- One twin screwdriver
- One special key for adjusting rear shock absorbers

Beverly Tourer 250ie



PIAGGIO®



**Chap. 05
Spare parts and
accessories**



05_01

Warnings (05_01)

WARNING



TO PREVENT ACCIDENTS AND TO GUARANTEE PROPER STABILITY, PERFORMANCE AND SAFETY, RIDE THE VEHICLE VERY CAREFULLY WHEN IT IS FITTED WITH ACCESSORIES OR WITH UNUSUAL LOADS.

WARNING



IT IS ALSO RECOMMENDED THAT "ORIGINAL PIAGGIO SPARE PARTS" BE USED, AS THESE ARE THE ONLY ONES OFFERING YOU THE SAME QUALITY GUARANTEE AS THOSE INITIALLY FITTED ON THE SCOOTER. THE USE OF NON-ORIGINAL SPARE PARTS RENDERS THE WARRANTY VOID.

WARNING



PIAGGIO MARKETS ITS OWN LINE OF ACCESSORIES THAT ARE RECOGNISED AND GUARANTEED FOR USE. IT IS THEREFORE ESSENTIAL, IN ORDER TO CHOOSE AND MOUNT THE ACCESSORIES CORRECTLY, TO CONTACT AN AUTHORISED DEALER OR SERVICE CENTRE. THE USE OF NON-ORIGINAL ACCESSORIES MAY AFFECT THE STABILITY AND OPERATION OF YOUR VEHICLE AND REDUCE SAFETY LEVELS WITH POTENTIAL RISKS FOR THE RIDER.

WARNING

NEVER RIDE THE SCOOTER EQUIPPED WITH ACCESSORIES (TOP BOX AND/OR WINDSHIELD) AT A SPEED HIGHER THAN 100 km/h.

THE SCOOTER CAN BE RIDDEN AT A HIGHER SPEED WITHOUT THE ACCESSORIES MENTIONED BEFORE WITHIN THE LIMITS ESTABLISHED BY LAW.

IF THERE SHOULD BE NOT-PIAGGIO ACCESSORIES INSTALLED, OR AN ABNORMAL LOAD, OR IF THE SCOOTER IS NOT IN A GENERALLY GOOD CONDITION, OR WHENEVER WEATHER CONDITIONS DEMAND IT, SPEED SHOULD BE REDUCED FURTHER.

WARNING

BE EXTREMELY CAREFUL WHEN INSTALLING AND REMOVING THE MECHANICAL ANTITHEFT DEVICE ON THE VEHICLE (U-SHAPED PADLOCK, DISC BLOCK, ETC.).

MAINLY DUE TO THE PROXIMITY TO THE BRAKE PIPES, TRANSMISSIONS AND/OR ELECTRIC CABLES, AN INCORRECT INSTALLATION OR REMOVAL OF THE ANTITHEFT DEVICE AS WELL AS LEAVING IT ON BEFORE STARTING THE VEHICLE CAN SERIOUSLY DAMAGE ITS COMPONENTS AND AFFECT THE CORRECT FUNCTIONING OF THE VEHICLE AND HARM THE USER.

Beverly Tourer 250ie



PIAGGIO®



**Chap. 06
Programmed
maintenance**



06_01

Scheduled maintenance table (06_01)

Adequate maintenance is fundamental to ensuring long-lasting, optimum operation and performance of your vehicle.

To this end, a series of checks and maintenance operations (at the owner's expense) have been suggested, which are included in the summary table on the following page. Any minor faults should be reported without delay to an **Authorised Service Centre or Dealer** without waiting until the next scheduled service to solve it.

All scheduled maintenance services must be carried out at the specified times, even if the stated mileage has not yet been reached. Carrying out scheduled services on time is necessary to ensure your warranty remains valid. For any further information concerning Warranty procedures and "Scheduled Maintenance", please refer to the "Warranty Booklet".

MAINTENANCE TABLE

km x 1,000	1	5	10	15	20	25	30	35	40	45	50	55	60	65	70	75	80
Driven pulley roller casing (greasing)			■		■		■		■		■		■		■		■
Safety locks	■		■				■				■				■		
Ignition spark plug					●				●				●				●
Centre stand (lubrication)		■	■	■	■	■	■	■	■	■	■	■	■	■	■	■	■
Driving belt			■		●		■		●		■		●		■		●
Throttle control - (adjustment)	■		■		■		■		■		■		■		■		■
Air filter			■		■		■		■		■		■		■		■
Oil filter	●		●		●		●		●		●		●		●		●
Valve clearance					■				■				■				■
Electrical system and battery	■		■		■		■		■		■		■		■		■
Coolant level *	■		■		■		■		■		■		■		■		■

km x 1,000	1	5	10	15	20	25	30	35	40	45	50	55	60	65	70	75	80
Brake fluid level *	■		■		■		■		■		■		■		■		■
Engine oil	●	■	●	■	●	■	●	■	●	■	●	■	●	■	●	■	●
Hub oil	●		■		●		■		●		■		●		■		●
Brake pads	■	■	■	■	■	■	■	■	■	■	■	■	■	■	■	■	■
Sliding blocks / variable speed rollers			●		●		●		●		●		●		●		●
Tyre pressure and wear	■		■		■		■		■		■		■		■		■
Vehicle road test	■		■		■		■		■		■		■		■		■
Suspensions	■		■		■		■		■		■		■		■		■
Steering	■		■		■		■		■		■		■		■		■

● Replacement

■ Check

* Replace every 2 years

RECOMMENDED PRODUCTS TABLE

Product	Description	Specifications
AGIP ROTRA 80W-90	Rear hub oil	SAE 80W/90 Oil that exceeds the requirements of API GL3 specifications
AGIP CITY HI TEC 4T	Oil to lubricate flexible transmissions (throttle control)	Oil for 4-stroke engines
AGIP FILTER OIL	Oil for air filter sponge	Mineral oil with specific additives for increased adhesiveness
AGIP GP 330	Grease for brake levers, throttle	White calcium complex soap-based spray grease with NLGI 2; ISO-L-XBCIB2

Product	Description	Specifications
AGIP CITY HI TEC 4T	Engine oil	SAE 5W-40, API SL, ACEA A3, JASO MA Synthetic oil
AGIP BRAKE 4	Brake fluid	FMVSS DOT 4 Synthetic fluid
SPECIAL AGIP PERMANENT fluid	coolant	Monoethylene glycol-based antifreeze fluid, CUNA NC 956-16

**UNIT OF MEASUREMENT - CONVERSION - ENGLISH
SYSTEM AND INTERNATIONAL SYSTEM (IS).**

1 Inch (in)	25.4 Millimetres (mm)
1 Foot (ft)	0.305 Meter (m)
1 Mile (mi)	1.609 Kilometre (km)
1 US Gallon (US gal)	3.785 Litre (l)
1 Pound (lb)	0.454 Kilogram (kg)
1 Cubic inch (in ³)	16.4 Cubic centimetres (cm ³)
1 Foot pound (ft lb)	1.356 Newton meter (Nm)
1 Miles per hour (mi/h)	1.602 Kilometres per hour (km/h)
1 Pound per square inch (PSI)	0.069 (bar)
1 Fahrenheit (°F)	32+(9/5) Celsius (°C)

TABLE OF CONTENTS

A

Air filter: 43

B

Battery: 47, 48

Brake: 46, 59

C

Clock: 12

D

Disc brake: 59

E

Engine oil: 36, 37

Engine stop: 14

F

Fuel: 18

Fuses: 49

H

Headlight: 54

Horn: 13

Hub oil: 38

I

Identification: 20

Immobilizer: 14, 16

Instrument panel: 11

K

Key switch: 12

Keys: 14

L

Light switch: 13

M

Maintenance: 35, 77, 78

Mirrors: 59

S

Saddle: 19

Scheduled maintenance: 78

Shock absorbers: 27

Spark plug: 42

Stand: 30

Start-up: 14

T

Tank: 18

Technical Data: 67

Top box: 21

Transmission: 31

Tyre pressure: 25

Tyres: 40



The descriptions and illustrations given in this publication are not binding. While the basic features as described and illustrated in this manual remain unchanged, PIAGGIO - GILERA reserves the right, at any time and without being required to update this publication beforehand, to make any changes to components, parts or accessory supplies, which it considers necessary to improve the product or which are required for manufacturing or construction reasons.

Not all versions shown in this publication are available in all Countries. The availability of individual versions should be confirmed with the official Piaggio sales network.

"© Copyright 2007 - PIAGGIO & C. S.p.A. Pontedera. All rights reserved. Reproduction of this publication in whole or in part is prohibited."

PIAGGIO & C. S.p.A. - After-Sales

V.le Rinaldo Piaggio, 23 - 56025 PONTEDERA (Pi)