



---

# WORKSHOP MANUAL

---

**639573**

---



**Beverly 500**

---



# WORKSHOP MANUAL

## Beverly 500

The descriptions and illustrations given in this publication are not binding. While the basic specifications as described and illustrated in this manual remain unchanged, PIAGGIO-GILERA reserves the right, at any time and without being required to update this publication beforehand, to make any changes to components, parts or accessories, which it considers necessary to improve the product or which are required for manufacturing or construction reasons.

Not all versions shown in this publication are available in all countries. The availability of single versions should be checked at the official Piaggio sales network.

"© Copyright 2005 - PIAGGIO & C. S.p.A. Pontedera. All rights reserved. Reproduction of this publication in whole or in part is prohibited."

PIAGGIO & C. S.p.A. - Q.C.S./After sales V.le Rinaldo Piaggio, 23 - 56025 PONTEDERA (Pi)  
[www.piaggio.com](http://www.piaggio.com)

---

---

# WORKSHOP MANUAL

## Beverly 500

This workshop manual has been drawn up by Piaggio & C. Spa to be used by the workshops of Piaggio-Gilera dealers. This manual is addressed to Piaggio service mechanics who are supposed to have a basic knowledge of mechanics principles and of scooter mounting techniques and procedures. Any important changes made to the scooters or to specific mounting operations will be promptly reported by updates to this manual. Nevertheless, no mounting work can be satisfactory if the necessary equipment and tools are unavailable. It is therefore advisable to read the sections of this manual relating to special tools, along with the special tool catalogue.

**N.B.** Provides key information to make the procedure easier to understand and carry out.

**CAUTION** Refers to specific procedures to carry out for preventing damages to the vehicle.

**WARNING** Refers to specific procedures to carry out to prevent injuries to the repairer.



**Personal safety** Failure to completely observe these instructions will result in serious risk of personal injury.



**Safeguarding the environment** Sections marked with this symbol indicate the correct use of the vehicle to prevent damaging the environment.



**Vehicle intactness** The incomplete or non-observance of these regulations leads to the risk of serious damage to the vehicle and sometimes even the invalidity of the guarantee.



## INDEX OF TOPICS

CHARACTERISTICS

CHAR

TOOLING

TOOL

MAINTENANCE

MAIN

ELECTRICAL SYSTEM

ELE SYS

ENGINE FROM VEHICLE

ENG VE

ENGINE

ENG

INJECTION

INJEC

SUSPENSIONS

SUSP

BRAKING SYSTEM

BRAK SYS

COOLING SYSTEM

COOL SYS

CHASSIS

CHAS

PRE-DELIVERY

PRE DE

TIME

TIME

## INDEX OF TOPICS

CHARACTERISTICS

CHAR

This section describes the general specifications of the vehicle.

---

## Rules

This section describes general safety rules for any maintenance operations performed on the vehicle.

---

### Safety rules

- Should it be necessary to keep the engine running while servicing, make sure that the area or room is well ventilated, and use special exhaust fans, if required. never let the engine run in an enclosed area. Exhaust fumes are toxic.
  - The battery electrolyte contains sulphuric acid. Protect your eyes, clothes and skin. Sulphuric acid is highly corrosive; in the event of contact with your eyes or skin, rinse thoroughly with abundant water and seek immediate medical attention.
  - The battery produces hydrogen, a gas that can be highly explosive. Do not smoke and avoid sparks or flames near the battery, especially when charging it.
  - Fuel is highly flammable, and in some conditions it can be explosive. Do not smoke in the working area, and avoid open flames or sparks.
  - Clean the brake pads in a well ventilated environment, directing the compressed air jet so as to not inhale the dust produced by the wear of the friction material. Even though the latter contains no asbestos, dust inhalation is harmful.
- 

### Maintenance rules

- Use original PIAGGIO spare parts and lubricants recommended by the Manufacturer. Non-original or non-conforming spares may damage the vehicle.
  - Use only the special tools designed for this scooter.
  - Always use new gaskets, sealing rings and split pins upon reassembly.
  - After removal, clean the components using non-flammable or low fire-point solvent. Lubricate all the work surfaces except the tapered couplings before refitting.
  - After reassembly, check that all components have been installed properly and that they are in good working order.
  - For removal, overhaul and reassembly operations use only tools provided with metric measures. Metric bolts, nuts and screws are not interchangeable with coupling members with English measurement. Using unsuitable coupling members and tools may damage the scooter.
  - Should any interventions to the scooter electrical system be required, check that the electrical connections - especially earth and battery connections - have been implemented properly.
-

**Vehicle identification**

Chassis prefix: ZAPM34200



Engine prefix: M341M



**Dimensions and mass**

**WEIGHT**

Specification	Desc./Quantity
Kerb weight in running order	193 Kg
Width (at the handles)	770 mm
Length	2215 mm
Wheel base	1550 mm
Height	1305 mm



**Engine**

**ENGINE**

Specification	Desc./Quantity
Engine	Single-cylinder, four-stroke
Bore	92 mm
Stroke	69 mm
Cubic capacity	460 cm <sup>3</sup>
Compression ratio	10.5: 1
Timing system	Single overhead camshaft with integrated tone wheel, control from flywheel side chain, 4 valves and automatic start-up valve lifting device.

Specification	Desc./Quantity
Valve clearance: intake	0.15 mm (when cold)
Valve clearance: discharge	0.15 mm (when cold)
Valve clearance adjustment	By threaded adjuster on the rockers
Engine idle speed	1500 ± 50 rpm
Air filter	sponge, impregnated with mixture (50% petrol and 50% oil)
CO % value (measured at the intake manifold)	1 - 1.5%
Starting system	Electric starter system with freewheel.
Lubrication	By trochoidal pump (inside the crankcase), pressure adjustment by-pass and oil filter.
Lubrication pressure	4 bar
Minimum allowed (at 100° C)	0.8 bar
Fuel supply	Electronic injection system with electric fuel pump, Ø 38 mm throttle body and single injector.
Max. power (shaft)	29 kW (39 CV) at 7250 rpm
Max. torque (shaft)	40 N-m (4 kgm) at 5500 rpm
Cooling system	Fluid circulation through a motor-driven pump, 3-way thermostat and electric fan.

## Transmission

### TRANSMISSIONS

Specification	Desc./Quantity
Transmission	With automatic expandable pulley variator with torque server, V belt, automatic clutch, gear reduction unit and transmission housing with forced air circulation cooling.

## Capacities

### CAPACITY

Specification	Desc./Quantity
Engine oil (empty)	1.7 lt.
Engine oil (at oil and filter change)	1.5 lt.
Fuel tank	approx. 13.2 litres (including reserve approx. 3 litres)
Rear hub	approx. 250 cc.
Cooling system	approx. 1.7 litres
Front fork	approx. 195 ± 3 cc in each fork leg

## Electrical system

### ELECTRIC SYSTEM

Specification	Desc./Quantity
Ignition type	High efficiency inductive ignition, integrated with variable injection, timing and dwell angle and separate HV coil.
Spark plug	NGK CR7EKB
Spark plug	CHAMPION RG6YC
Battery	Dry charge lead battery 12V-12Ah
Fuses	1 x 30 A 2 x 15 A 2 x 10 A 3 x 7.5 A 2 x 5 A
Generator	Three-phase alternating current



## Frame and suspensions

### CHASSIS AND SUSPENSIONS

Specification	Desc./Quantity
Chassis	Welded steel pipes with pressed sheet metal stiffening
Front suspension	Hydraulic telescopic fork with diameter 41 mm stems
Front fork max. stroke	104 mm
Rear suspension	Engine based on oscillating fork pivoted to the chassis by 1-freedom degree oscillating arm. Pair of dual effect hydraulic shock absorbers and coaxial springs with 4-position preload adjustment
Rear shock absorber max. travel	95.5 mm

## Brakes

### BRAKE SYSTEM

Specification	Desc./Quantity
Front brakes	Twin disc, diameter 260 mm with hydraulic control. The right-hand brake calliper is actuated by the right-hand brake lever on the handlebars, the left-hand brake calliper is controlled by the integral brake system.
Rear brakes	Disc brake, diameter 240 mm with hydraulic control actuated by the integral brake system.
Integral brake system	Actuated by the left-hand brake lever on the handlebars, operating a pressure splitting valve that actuates the left-hand front brake calliper and the rear brake calliper.

## Wheels and tyres

### WHEELS AND TYRES

Specification	Desc./Quantity
Light alloy rims (Front rim)	16"x3"
Light alloy rims (rear rim)	14"x4.50"
Tyres (front)	Pirelli 110/70 - 16" - GTS 23 M/C - 52 S - TUBELESS
Tyres (rear)	Pirelli 150/70 14" - GTS 24 M/C - 66 S - TUBELESS
Tyre pressure (when cold) front	2.2 bar
Tyre pressure (when cold) rear	2.2 bar (2.3 bar with passenger)

N.B.

**CHECK AND ADJUST TYRE PRESSURE WITH TYRES AT AMBIENT TEMPERATURE. ADJUST PRESSURE ACCORDING TO THE WEIGHT OF RIDER AND ACCESSORIES.**

CAUTION



**IT IS MANDATORY TO ADOPT EXCLUSIVELY "S" CLASS TYRES, WHICH GUARANTEE CORRECT VEHICLE PERFORMANCE AT THE DIFFERENT SCOOTER SPEEDS. USING ANY OTHER TYRE MAY RESULT IN VEHICLE INSTABILITY. IT IS ADVISABLE TO USE TYRE TYPES RECOMMENDED BY PIAGGIO.**

## Tightening Torques

### CHASSIS

Name	Torque in Nm
Electric pump locking ring nut	20

Name	Torque in Nm
Chassis cross-member lower screws	16 - 25
chassis front cross-member upper screws	6 - 10

### **BRAKE SYSTEM**

Name	Torque in Nm
Brake calliper coupling	20 - 24
Front brake disc mounting	11 ÷ 13
Rear brake disc mounting	11 ÷ 13
Front brake calliper mounting on fork	20 ÷ 25
Pipe / brake calliper coupling	20 ÷ 25
Circuit bleed calliper fitting	12 - 16

### **FRONT SUSPENSION**

Name	Torque in Nm
Front wheel axle	45 ÷ 50
Holding torque of lower ring nut	20 ÷ 25
Fork stem mounting to the plate	20 ÷ 25
Steering lower ring nut	10 - 13 **
Upper steering ring nut	36 - 39
Stem upper cap	35 - 55
Fixing screw handlebar to steering tube	45 ÷ 50
Pumping element fixing screw	25 - 35
Safety screw on fork leg	6 ÷ 7
Wheel fastening screws	33 - 37

\* tighten and loosen completely. \*\* tighten and loosen by 90°.

### **REAR SUSPENSION**

Name	Torque in Nm
Lock nut	40 ÷ 50
Nut for bolt securing swinging arm to chassis	66 ÷ 73
Central stand retainers	25 ÷ 30
Rear shock-absorber lower retainers	33 ÷ 41
Muffler heat guard retainers	6 - 8
Rear shock absorber upper retainers	33 ÷ 41
Swinging arm to engine retainer, muffler side	66 ÷ 70
swinging arm to engine retainer, transmission side	100 - 120
Side stand clamp	15 ÷ 20
Shock absorber to crankcase bracket fastener	20 - 25
rear shock absorber to muffler support arm bracket fastener	20 - 25
rod retainer	33 - 41
bolt securing swinging arm to chassis	14 ÷ 17
Rear wheel axle	104 ÷ 126

### **ENGINE ASSEMBLY**

Name	Torque in Nm
starter motor retainers	11 - 13

### **THERMAL UNIT AND TIMING SYSTEM**

Name	Torque in Nm
Spark plug	12 ÷ 14
Head fixing stud bolts	***
Head fixing nuts	10 - 12
Exhaust / intake head fixing nuts	10 - 12
Head lubrication control jet	5 - 7
Coolant temperature sensor	10 ÷ 12
counterweight mass fixing screw	7 - 8.5
Tensioner sliding block fixing screw	10 - 14
Rpm timing sensor fixing screw	3 - 4
injector fixing screw	3 ÷ 4
Revolution timing sensor fixing screw	3 ÷ 4
Valve lifter mass stop bell fixing screws	30 - 35
inlet manifold fixing screws	11 - 13
Tappet cover fixing screws	7 - 9

Name	Torque in Nm
Throttle body fixing screws	11 ÷ 13
camshaft retaining bracket fixing screws	4 - 6
Head fixing screws	10 - 12
Lambda probe on exhaust manifold	10 - 12
Muffler to bracket fixing screw	14 - 16

\*\*\* Apply a preliminary torque of 7 N·m in a crossed sequence. - Tighten by 90° in a crossed sequence. - Tighten again by 90° in a crossed sequence.

### CRANKCASE AND CRANKSHAFT

Name	Torque in Nm
Countershaft fixing nut	25 ÷ 29
Engine oil filter	12 - 16
Engine oil drainage plug	24 ÷ 30
Engine-crankcase coupling screws	11 ÷ 13
Oil pump screws	5 - 6
Gear mounting on crankshaft screws	10 - 12
Bulkhead screws for oil pump housing cover	8 - 10

### FINAL REDUCTION

Name	Torque in Nm
Rear hub cover screws	24 ÷ 27

### TRANSMISSION COVER

Name	Torque in Nm
Driven pulley nut	92 - 100
Driving pulley nut	160 - 175
Anti-vibration roller screw	16.7 ÷ 19.6
M8 retainers for transmission cover	23 ÷ 26
M6 retainer	11 ÷ 13
Anti-vibration roller retainer	17 - 19
Clutch ring nut	65 - 75
Air conveyor unit screws	7.9 N
Water pump cover screws	3 ÷ 4
External transmission cover screws	7 ÷ 9
Flywheel cover screws	11 - 13

### FLYWHEEL COVER

Name	Torque in Nm
Flywheel fixing nut	115 - 125
Stator retainers	8 - 10
Blow-by recovery duct fixing screws	3 - 4
Screw fixing freewheel to flywheel	13 ÷ 15
Stator cable harness guide bracket screws	3 - 4

### LUBRICATION

Name	Torque in Nm
Oil pump cover screws	0.7 ÷ 0.9
Screws fixing oil pump to crankcase	5 - 6

#### See also

Fuel tank  
[Overhaul](#)  
[Refitting](#)  
[Refitting](#)

## Overhaul data

This section provides the main information for scooter servicing.

**Assembly clearances**

**Cylinder - piston assy.**

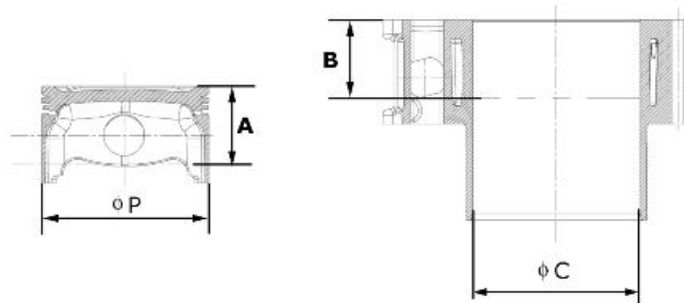

**HEIGHT AT WHICH THE DIAMETER SHOULD BE MEASURED**

Specification	Desc./Quantity
A	43.2 mm
B	43 mm

**CYLINDER - PISTON**

Specification	Desc./Quantity
Cylinder diameter C	92+0.018-0.01
Piston diameter P	91.916-0.029-0.057

**CATEGORIES OF COUPLING**

Name	Initials	Cylinder	Piston	Play on fitting
Cylinder- Piston	A	91.990 - 91.997	91.947 - 91.954	0.036 - 0.050
Cylinder- Piston	B	91.997 - 92.004	91.954 - 91.961	0.036 - 0.050
Cylinder- Piston	C	92.004 - 92.011	91.961 - 91.968	0.036 - 0.050
Cylinder- Piston	D	92.011 - 92.018	91.968 - 91.975	0.036 - 0.050

N.B.

**THE PISTON MUST BE INSTALLED WITH THE ARROW FACING TOWARDS THE EXHAUST SIDE, THE PISTON RINGS MUST BE INSTALLED WITH THE WORD «TOP» OR THE STAMPED MARK FACING UPWARDS.**

**Piston rings**

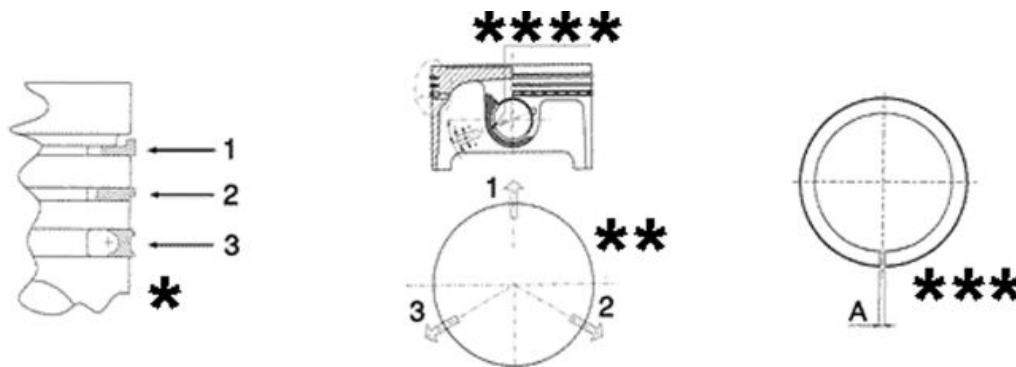

\* Fit rings «2» and «3» with the word «TOP» facing upwards.

\*\* Position the openings in the rings as shown here.

\*\*\* Value «A» of sealing ring inside the cylinder

\*\*\*\* Ring opening

**SEALING RINGS**

Name	Initials	Cylinder	Piston	Play on fitting
1st Compression ring	A	0.15 ÷ 0.35	0.5	</>
Middle piston ring	A	0.25 ÷ 0.50	0.65	</>
Oil scraper ring	A	0.25 ÷ 0.50	0.65	</>

**Crankcase - crankshaft - connecting rod**

**Diameter of crankshaft bearings.**

Measure the capacity on both axes x-y.

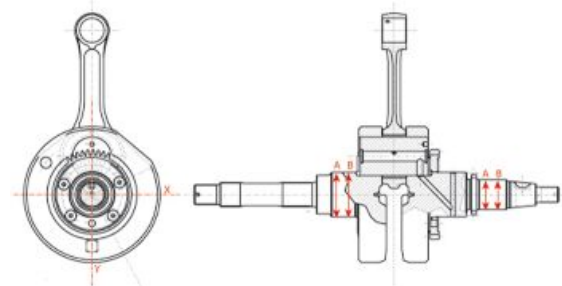

**CRANKSHAFT**

Specification	Desc./Quantity
Cat. 1	Standard diameter: 40.010 ÷ 40.016
Cat. 2	Standard diameter: 40.016 ÷ 40.022

**Crankshaft alignment**

**Specific tooling**

020335Y Magnetic support for dial gauge

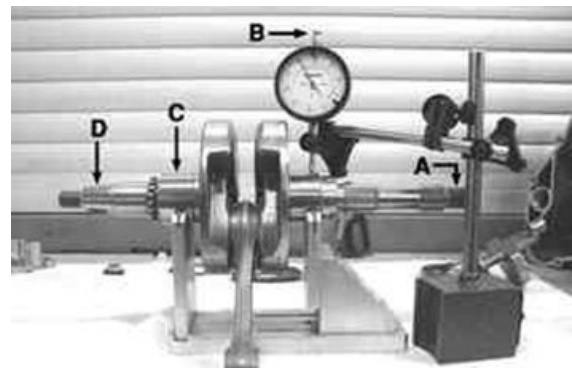

**MAX. ADMISSIBLE DISPLACEMENT**

Specification	Desc./Quantity
A =	0.15 mm
B =	0.010 mm
C =	0.010 mm
D =	0.10 mm

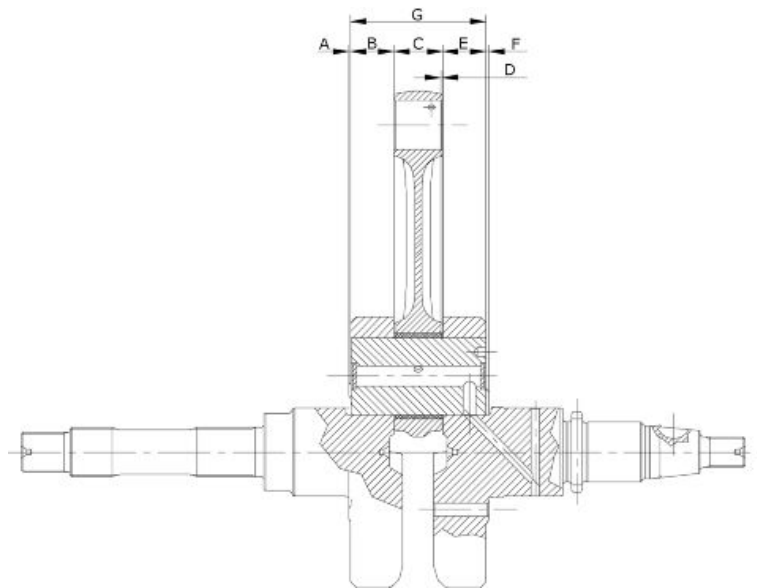

**AXIAL CLEARANCE BETWEEN CRANKSHAFT AND CONNECTING ROD**

Name	Description	Dimensions	Initials	Quantity
Transmission-side shoulder		$0.8 \pm 0.025$	A	D= 0.20 - 0.40
Transmission-side half-shaft		$19.6 + 0.050$	B	D= 0.20 - 0.40
Connecting rod		$22 \ 0.10-0.15$	C	D= 0.20 - 0.40
Flywheel-side shoulder		$13 \pm 0.025$	F	D= 0.20 - 0.40
Flywheel-side half-shaft		$19.6 +0.050$	E	D= 0.20 - 0.40
Complete drive shaft		$63.5+0.1-0.05$	G	D= 0.20 - 0.40

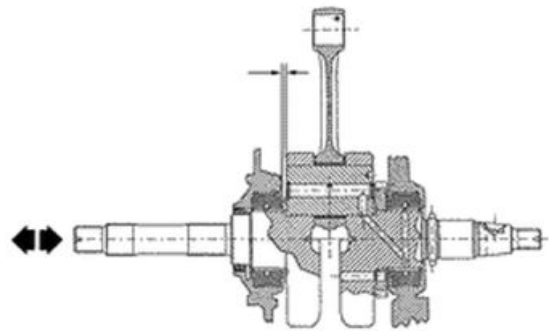

**Characteristic**

**Drive shaft / crankcase axial clearance:**

0.1 - 0.5 mm (when cold)

### Slot packing system

Shimming system for limiting the compression ratio  $R_c = 10.5 : 1$

DISTANCE «A» IS A PROTRUSION OR RECESS VALUE OF THE PISTON CROWN WITH RESPECT TO THE CYLINDER PLANE.

DISTANCE «A» HELPS DETERMINE THE THICKNESS OF GASKET «B» THAT HAS TO BE FITTED TO THE CYLINDER HEAD IN ORDER TO RESTORE COMPRESSION RATIO. BASE GASKET «B» MUST BE THICKER THE MORE THE PLANE FORMED BY THE PISTON TOP PROTRUDES FROM THE PLANE FORMED BY THE CYLINDER HEAD. ON THE OTHER HAND, THE MORE THE PISTON TOP IS RECESSED INTO THE CYLINDER TOP PLANE, THE SMALLER THE GASKET THICKNESS.

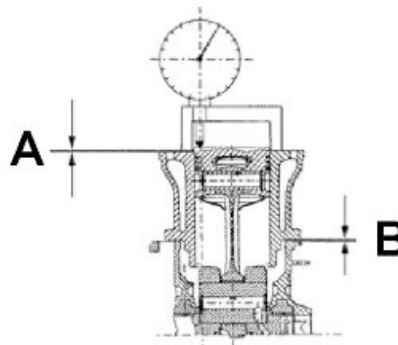

#### BASE GASKET THICKNESS

Name	Measure A	Thickness
«A» MEASURE TAKEN	- 0.185 - - 0.10	0.4 ± 0.05
«A» MEASURE TAKEN	- 0.10 - + 0.10	0.6 ± 0.05
«A» MEASURE TAKEN	+ 0.10 ÷ + 0.185	0.8 ± 0.05

N.B.

VALUES INDICATED WITH «-» REFER TO PISTON CROWN RECESSES WITH RESPECT TO THE CYLINDER PLANE.

N.B.

DISTANCE «A» MUST BE MEASURED WITHOUT ANY GASKET FITTED AT «B»

### Products

#### PRODUCTS

Product	Description	Specifications
AGIP ROTRA 80W-90	Rear hub oil	SAE 80W/90 Oil that exceeds the requirements of API GL3 specifications
AGIP FILTER OIL	Oil for air filter sponge	Mineral oil with specific additives for increased adhesiveness
AGIP CITY HI TEC 4T	Engine oil	SAE 5W-40, API SL, ACEA A3, JASO MA Synthetic oil
AGIP BRAKE 4	Brake fluid	FMVSS DOT 4 Synthetic fluid
AGIP PERMANENT SPEZIAL	coolant	Monoethylene glycol-based antifreeze fluid, CUNA NC 956-16
AUTOSOL METAL POLISH	Muffler cleaning paste	special product for cleaning and polishing stainless steel muffler
AGIP GP 330	Grease for brake levers, throttle	White calcium complex soap-based spray grease with NLGI 2; ISO-L-XBCIB2
AGIP CITY TEC 2T	Mixer oil	synthetic oil for 2-stroke engines: JASO FC, ISO-L-EGD

## INDEX OF TOPICS

TOOLING

TOOL



**SPECIAL TOOLS**

Stores code	Description	
001330Y	Tool for fitting steering seats	
001467Y002	Driver for OD 73 mm bearing	
001467Y006	Pliers to extract 20 mm bearings	
001467Y007	Driver for OD 54-mm bearings	
001467Y008	Pliers to extract 17 mm ø bearings	
001467Y014	Pliers to extract ø 15-mm bearings	

Stores code	Description	
001467Y031	Bell	

001467Y034 Pliers to extract ø 15-mm bearings



001467Y035	Belle for OD 47-mm bearings	
------------	-----------------------------	--



002465Y Pliers for circlips

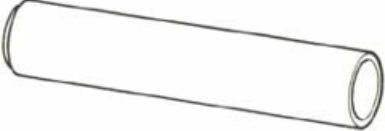





006029Y	Punch for fitting fifth wheel seat on steering tube	
---------	---	--

020004Y Punch for removing fifth wheels from headstock

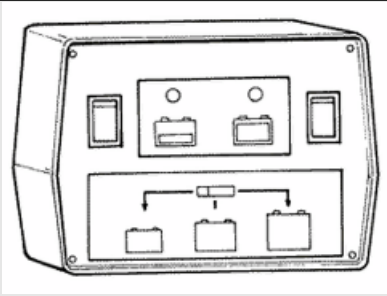

Stores code	Description	
020055Y	Wrench for steering tube ring nut	
020150Y	Air heater support	
020151Y	Air heater	
020193Y	Oil pressure gauge	
020201Y	Spacer bushing driving tube	
020262Y	Crankcase splitting strip	
020306Y	Punch for assembling valve seal rings	

Stores code	Description	
020329Y	MityVac vacuum-operated pump	
020330Y	Stroboscopic light to check timing	
020331Y	Digital multimeter	
020333Y	Single battery charger	
020334Y	Multiple battery charger	

Stores code	Description	
020335Y	Magnetic support for dial gauge	

020357Y	Adaptor 32 x 35 mm	
020358Y	37x40-mm adaptor	
020359Y	42x47-mm adaptor	











020360Y	Adaptor 52 x 55 mm	
---------	--------------------	---

020364Y	25-mm guide	
---------	-------------	---

020376Y	Adaptor handle	
---------	----------------	---

020382Y012	bush (valve removing tool)	
------------	----------------------------	--

Stores code	Description	
020412Y	15 mm guide	
020424Y	Driven pulley roller casing fitting punch	
020431Y	Valve oil seal extractor	
020434Y	Oil pressure control fitting	
020439Y	17 mm guide	

Stores code	Description	
020444Y	Tool for fitting/ removing the driven pulley clutch	
020456Y	Ø 24 mm adaptor	
020458Y	Puller for lower bearing on steering tube	
020459Y	Punch for fitting bearing on steering tube	
020460Y	Scooter diagnosis and tester	
020467Y	Flywheel extractor	

Stores code	Description
-------------	-------------

020468Y

Piston fitting band



020469Y

Reprogramming kit for scooter diagnostic tester



020470Y

Pin retainers installation tool



020471Y

Pin for countershaft timing















020472Y

Flywheel lock wrench





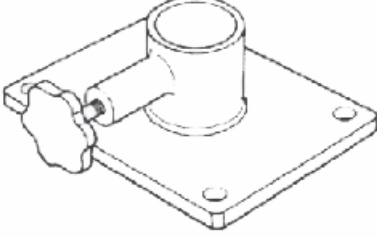

Stores code	Description	
020474Y	Driving pulley lock wrench	
020475Y	Piston position checking tool	
020476Y	Stud bolt set	
020478Y	Punch for driven pulley roller casing	
020479Y	Countershaft lock wrench	
020480Y	Petrol pressure check set	

Stores code	Description	
020481Y	Control unit interface wiring	
020482Y	Engine support	
020483Y	30 mm guide	
020512Y	Piston fitting fork	
020527Y	Engine support base	
020604Y011	Fitting adapter	
020565Y	Flywheel lock calliper spanner	

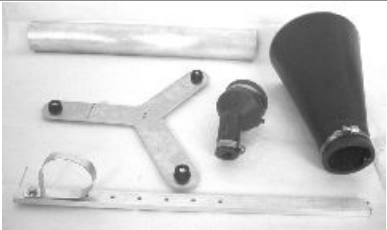
---

Stores code	Description	
020623Y	Pre-service gas extraction set	 A collection of tools for gas extraction, including a long metal rod, a Y-shaped metal bracket, a black cylindrical component, a metal ring, and a long metal bar.
020625Y	Kit for sampling gas from the exhaust manifold	 A kit for sampling gas from the exhaust manifold, featuring a long metal tube with a corrugated section, a small metal fitting, and several small bolts or nuts.
020640y	software euro3	 Two CD-ROMs for Euro3 software, with the text 'PIRACCHI', 'PIRACCHI', and 'EURO3' visible on the discs.

---

# INDEX OF TOPICS

**MAINTENANCE**

**MAIN**



## Maintenance chart

Adequate maintenance is fundamental to ensuring long-lasting, optimum operation and performance of your vehicle.

To this end, a series of checks and maintenance operations (at the owner's expense) have been suggested, which are included in the summary table on the following page. Any minor faults should be reported without delay to an **Authorised Service Centre or Dealer** without waiting until the next scheduled service to solve it.

All scheduled maintenance services must be carried out at the specified intervals, even if the stated mileage has not yet been reached. Punctual scooter servicing is essential to ensure your warranty remains valid. For any further information concerning Warranty procedures and "Scheduled Maintenance", please refer to the "Warranty Booklet".

### **EVERY 2 YEARS**

60'

#### Action

Coolant - change
Brake fluid - change

### **AFTER 1,000 KM**

#### Action

Safety locks - check
Throttle lever - adjustment
Engine oil - change
Electrical system and battery - check
Coolant level - check
Brake fluid level - check
Engine oil - replacement
Brake pads - check condition and wear
Tyre pressure and wear - check
Vehicle and brake test - road test
Hub oil - change
Crankcase breather - empty
Steering - adjustment
Injection system pipework - visual check

### **AFTER 10,000 KM AFTER 30,000 KM AFTER 50,000 KM AND AFTER 70,000 KM**

#### Action

Safety locks - check
Spark plug - replacement
Driving belt - replacement

**Action**

Throttle lever - adjustment
Air filter - check
Air filter belt compartment - check
Engine oil - change
Valve clearance - check
Electrical system and battery - check
Coolant level - check
Brake fluid level - check
Engine oil - replacement
Brake pads - check condition and wear
Sliding block / variable speed rollers - change
Tyre pressure and wear - check
Vehicle and brake test - road test
Hub oil - check
Stand control roller - replace
Suspensions - check
Steering - Check
Injection system pipework - visual check
Crankcase breather - empty

**AFTER 20,000 KM AFTER 40,000 KM AFTER 60,000 KM AND AFTER 80,000 KM****Action**

Safety locks - check
Bushing of driven pulley
Spark plug - replacement
Driving belt - replacement
Throttle lever - adjustment
Air filter - check
Air filter belt compartment - check
Engine oil - change
Valve clearance - check
Electrical system and battery - check
Coolant level - check
Brake fluid level - check
Engine oil - replacement
Brake pads - check condition and wear
Sliding block / variable speed rollers - change
Tyre pressure and wear - check
Vehicle and brake test - road test
Hub oil - check
Stand control roller - replace
Crankcase breather - empty
Suspensions - check
Steering - Check
Injection system pipework - visual check
Fuel filter - check

**Spark plug****Check and replacement****CAUTION**

THE SPARK PLUG MUST BE REMOVED WITH COLD ENGINE. THE SPARK PLUG SHOULD BE CHECKED EVERY 6,000 KM AND REPLACED EVERY 12,000 KM. THE USE OF NON-CONFORMING IGNITION CONTROL UNITS AND SPARK PLUGS OTHER THAN THOSE PRESCRIBED CAN SERIOUSLY DAMAGE THE ENGINE.

**Characteristic****Recommended spark plugs:**

CHAMPION RG6YC - NGK CR 7 EKB

- Position the scooter on centre stand.



- Open the door on the left side and remove the relevant screw lifting from the lower part in the specific groove.
- Disconnect the shielded spark plug cap
- Unscrew the spark plug.
- Check the conditions of the spark plug, make sure the insulation is intact, that the electrodes are not excessively worn or grimy, the conditions of the washer, and measure the distance between the electrodes using the appropriate feeler gauge.

**Characteristic**

**Electrode gap**

0.7-0.8 mm

Adjust the gap if necessary, carefully bending the earth electrode. In the event of irregularity, replace the spark plug with a recommended type.

- Fit the spark plug with the correct inclination and manually screw it all the way down, then use the special spanner to tighten it.

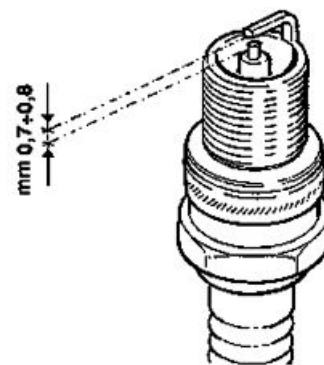

**Locking torques (N\*m)**

**Spark plug** 12 ÷ 14

- Insert the cap onto the spark plug and proceed with the reassembly operations.

**Hub oil**

**Check**

- Park the scooter on flat ground and rest it on the central stand.
- Unscrew the oil dipstick "A", dry it with a clean cloth and reinsert it, screwing it in thoroughly.
- Pull out the dipstick and check that the oil level is between the MAX. and MIN. levels indicated on the dipstick (see figure); if the level is below the MIN value, restore the proper amount of oil in the hub.
- Screw the oil bar back on, checking that it is tightly in place.

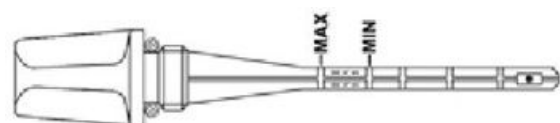
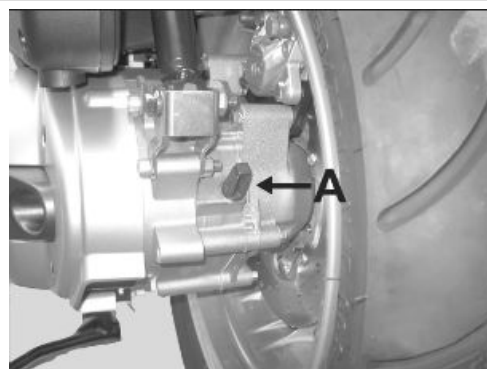

## Replacement

- Remove the oil filler cap "A".
- Prepare a suitable container.
- Remove the oil drainage cap "B" and let the oil drain out completely.
- Tighten the drainage cap with its gasket and refill.
- Remove the oil loading cap

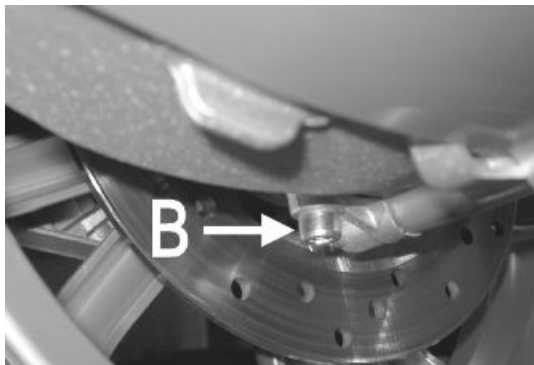

### Recommended products

#### AGIP ROTRA 80W-90 rear hub oil

SAE 80W/90 Oil that exceeds the requirements of API GL3 specifications

### Characteristic

#### Rear hub oil

Capacity approximately 250 cc

## Air filter

- Remove the air cleaner cover after unscrewing the 9 fixing screws.
- Take out the filtering element.
- Replace the air filter with a new one.

Check the blow-by and condensate outlet pipe; empty if when full.



### Cleaning (Every 12,000 km):

- Wash with water and car shampoo.
- Dry with short blasts of compressed air and a clean cloth.
- Soak with a 50% mixture of gasoline and oil.
- Drip dry the filtering element and then squeeze it with your hands without wringing.
- Refit the filtering element.

#### CAUTION

**NEVER RUN THE ENGINE WITHOUT THE AIR FILTER, THIS WILL RESULT IN AN EXCESSIVE CYLINDER AND PISTON WEAR AND ALSO IN CARBURETTOR DAMAGE.**

#### CAUTION

**WHEN TRAVELLING ON DUSTY ROADS, THE AIR FILTER MUST BE CLEANED MORE OFTEN THAN SHOWN IN THE SCHEDULED MAINTENANCE CHART.**

### Recommended products

#### AGIP FILTER OIL Oil for air filter sponge



Mineral oil with specific additives for increased adhesiveness

**N.B.**

**FAILURE TO OBSERVE THE FILTERING ELEMENT CLEANING RULES MAY LEAD INCORRECT LUBRICATION OF THE PART INVOLVED. POOR LUBRICATION COMPROMISES THE FILTERING ELEMENT CAPACITY. EXCESSIVE LUBRICATION, AS WELL AS A DIRTY FILTER, RESULTS IN A RICH CARBURATION.**

## Engine oil

In 4T engines, the engine oil is used to lubricate the distribution elements, the bench bearings and the thermal group. **An insufficient quantity of oil can cause serious damage to the engine.**

In all 4T engines, the deterioration of the oil characteristics, or a certain consumption should be considered normal, especially if during the run-in period. Consumption levels in particular can be influenced by the conditions of use (e.g.: oil consumption increases when driving at "full throttle").

## Check

This operation must be carried out with the engine cold and following the procedure below:

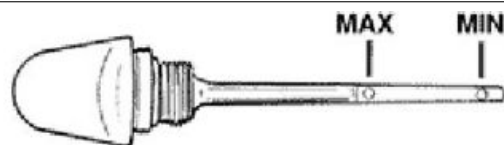

- 1) Rest the vehicle on the central stand and on a flat ground.
- 2) Unscrew the cap/dipstick "A", dry it with a clean cloth and reinsert it, **screwing it thoroughly**.
- 3) Remove the cap/dipstick again and check that the level is between the max. and min levels; top-up, if required.

Topping up from the MIN to MAX. level requires around 1700 cc.

If the check is carried out after the vehicle has been used, and therefore with a hot engine, the level line will be lower; in order to carry out a correct check it is necessary to wait at least 10 minutes after the engine has been stopped, so as to get the correct level.

### Oil top up

The oil should be topped up after having checked the level and in any case by adding oil **without ever exceeding the MAX. level**.

The restoration level between the **MIN** and **MAX** levels implies a quantity of oil **of approx. 400 cc.**

## Engine oil filter

**CAUTION**

**DO NOT DISPOSE OF OIL IN THE ENVIRONMENT. OIL, GASKET AND FILTER SHOULD BE DISPOSED OF ACCORDING TO THE REGULATIONS IN FORCE.**

**WARNING**

**AVOID TOUCHING PARTS OF THE ENGINE WHEN HOT, AS THIS MAY CAUSE BURNS.**

- Remove the muffler.
- Remove the filler plug.

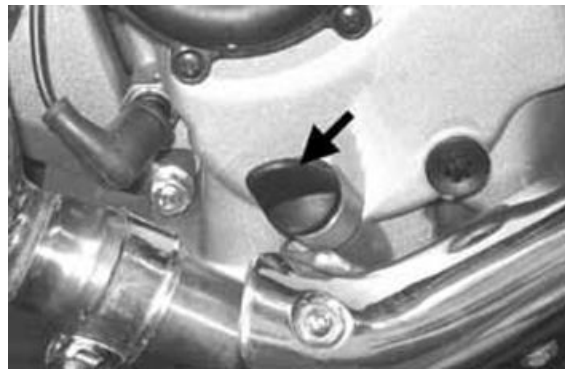

- Remove and clean the mesh pre-filter of the drain cap with compressed air.

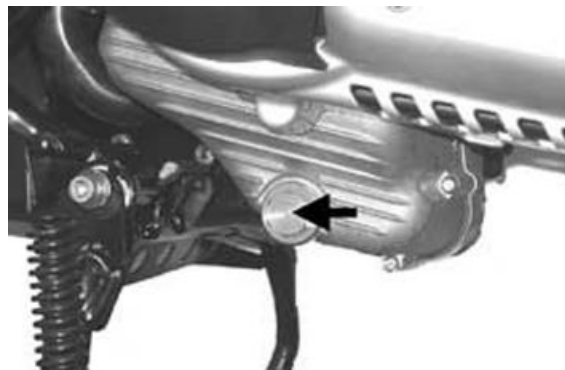

- Use a belt spanner for filters to remove cartridge filter "C".
- Make sure the pre-filter and drain cap O-rings are in good condition.
- Lubricate them and refit the mesh filter and oil drain cap by tightening to the prescribed torque.
- Refit a new cartridge filter making sure to lubricate the O-ring before fitting, then screw until it comes into contact with the seal and further tighten to the prescribed torque.

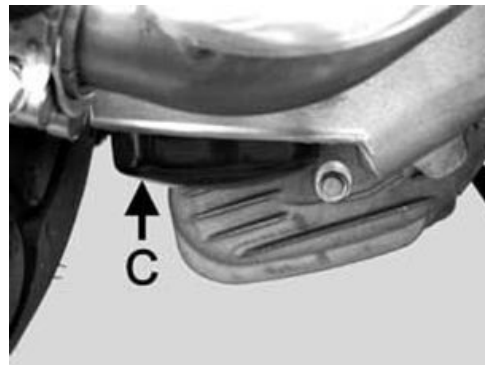

- Refit the muffler.
- Add recommended engine oil.
- Start the engine and let it run for a few minutes and then turn it off.

After 5 minutes check the level and top up, if necessary, **never exceed the MAX. level.**

**N.B.**

**IF THE OIL IS CHANGED WITHOUT CHANGING THE CARTRIDGE FILTER (1ST COUPON) ADD AROUND 1500 CC OF OIL INSTEAD OF 1700 CC SINCE PART OF THE LUBRICATION CIRCUIT IS FILLED.**

### Characteristic

#### Engine oil:

1700 cm<sup>3</sup>

#### Locking torques (N\*m)

---

Engine oil drainage plug 24 ÷ 30 Engine oil filter 12 - 16

---

## Oil pressure warning light

---

### Warning light (low oil pressure)

The vehicle is equipped with a warning light on the instrument panel that lights up when the key is turned to the «ON» position. However, this light should switch off once the engine has been started.

**If the light comes on during braking, at idling speed or while turning, it is necessary to first switch off the engine and then to check the oil level and the lubrication system**



---

## Checking the valve clearance

---

- To check the clearance in the valves collimate the references between the cam shaft control pulley and head.
- Use a feeler to make sure the clearance between the valve and register screw correspond to the indicated values. If the clearance does not correspond, adjust it by loosening the lock nut using a screwdriver on the set screw as shown in the figure.



### Characteristic

#### Valve clearance: intake

0.15 mm (when cold)

#### Valve clearance: discharge

0.15 mm (when cold)

---

## Cooling system

---

## Level check

The fluid level inspection should be carried out every 6,000 km when the motor is cold, following the methods indicated below:

- Rest the scooter on the central stand and on a flat ground.
- Loosen the screw shown in the figure and remove the expansion tank cover located on the right side of the scooter.
- Remove the expansion tank cap and top up, if the fluid level is near to or below the MIN level into the expansion tank. The fluid level should always be between the "MIN" and "MAX." level.
- To check the level, look into the expansion tank: the two marks into the expansion tank indicate the two levels, "MIN" and "MAX.".
- The coolant consists of a mixture of 50% demineralised water and ethylene glycol and corrosion inhibitors based anti-freeze solution.

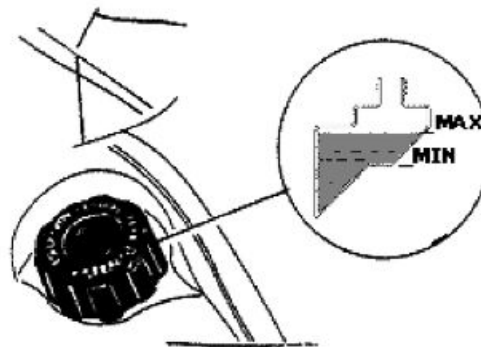

### CAUTION

DO NOT EXCEED THE MAX. LEVEL WHEN FILLING SO AS TO AVOID THE COOLANT ESCAPING FROM THE EXPANSION TANK WHEN THE vehicle IS IN USE.

### N.B.

THE COOLANT CONSISTS OF A MIXTURE OF DE-IONISED WATER AND FLUID FOR SEALED CIRCUITS. THE RESULTING MIXTURE ALLOWS A DECREASE OF THE FREEZING POINT TO -35°C. THE MIXTURE AT A PRESSURE OF 0.9 BAR INCREASES THE BOILING POINT TO APPROX. 125°C. THE RECOMMENDED FLUID IS ALSO PROTECTIVE FOR ALUMINIUM ALLOYS, AND OVER TIME THIS FEATURE MAY DECREASE. PERIODICAL REPLACEMENT IS THEREFORE ADVISABLE.

### See also

[Cooling system](#)

## Braking system

---

## Level check

- Rest the scooter on a flat ground and on the central stand.
- Remove the brake pump cover as shown in the figure.



- Check the brake fluid level by the special indicator located on the pump, as shown in the figure.



**N.B.**

**THE LEVEL TENDS TO DROP AS THE BRAKE PADS GET WORN, A MINIMUM LEVEL SHOULD NOT BE REACHED. IF THE LEVEL IS TOO LOW, CHECK AND FIX THE SYSTEM SEALS, IF REQUIRED. TOP UP THE PUMP TANK, IF REQUIRED, CONSIDERING THAT THE "MAX." LEVEL MUST ONLY BE OBTAINED WITH NEW PADS.**

---

## Top-up

**CAUTION**

**ONLY USE DOT 4-CLASSIFIED BRAKE FLUID.**

Proceed as follows:

- Rest the scooter on a flat ground and on the central stand.
- Remove the brake pump cover as shown in the figure.



- Remove the tank cap by loosening its two screws, remove the gasket and top up the level, using only the prescribed fluid without exceeding the maximum level.

**CAUTION**

AVOID CONTACT OF THE BRAKE FLUID WITH YOUR EYES, SKIN, AND CLOTHING. IN CASE OF ACCIDENTAL CONTACT, WASH WITH WATER.

**WARNING**

BRAKE CIRCUIT FLUID IS VERY CORROSIVE; DO NOT LET IT COME INTO CONTACT WITH PAINTED PARTS.

**WARNING**

THE BRAKE FLUID IS HYGROSCOPIC, THAT IS, IT ABSORBS MOISTURE FROM THE SURROUNDING AIR. IF THE HUMIDITY IN THE BRAKING FLUID EXCEEDS A CERTAIN VALUE, IT WILL LEAD TO INEFFICIENT BRAKING; FOR THIS REASON, NEVER USE BRAKING FLUID FROM CONTAINERS THAT HAVE ALREADY BEEN OPENED, OR PARTIALLY USED.

**Characteristic****Prescribed fluid:**

TUTELA TOP 4

Under normal climatic conditions, the fluid must be changed every 20,000 km or anyway every two years.

**N.B.**

**SEE THE BRAKING SYSTEM CHAPTER WITH REGARD TO THE CHANGING OF BRAKE FLUID AND THE BLEEDING OF AIR FROM THE CIRCUITS.**



## Headlight adjustment

- Place the scooter in use conditions, with tyres inflated to the prescribed pressure on flat ground at 10 m from a white screen placed in dim light.
- Make sure that the scooter's axle is perpendicular to the screen.
- Turn the headlight on and check that the limit of the light beam projected onto the screen does not exceed  $9/10$  of the headlight centre height from the ground and that it is not less than  $7/10$ .

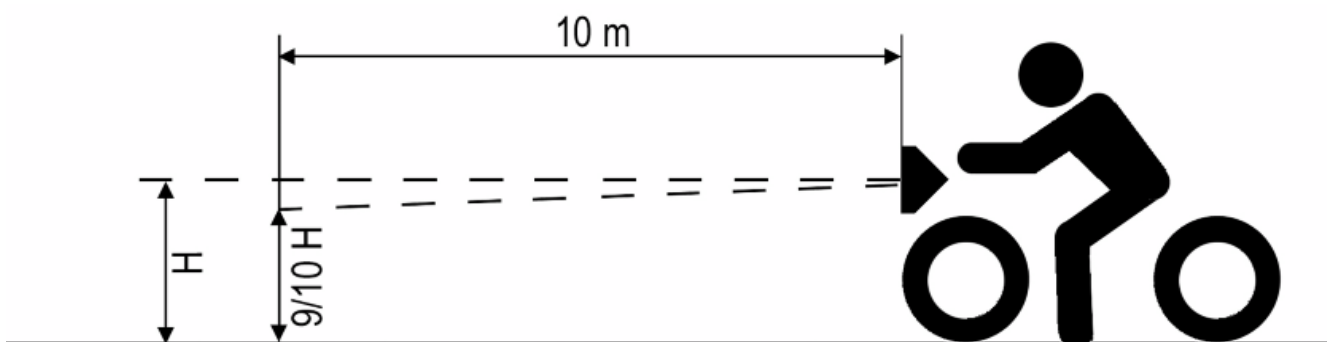

- Otherwise, adjust the right headlight by the screw shown in the figure, which can be accessed by removing the front shield connecting member.

**N.B.**

**THE ABOVE PROCEDURE COMPLIES WITH THE EUROPEAN STANDARDS REGARDING MAXIMUM AND MINIMUM HEIGHT OF LIGHT BEAMS. REFER TO THE STATUTORY REGULATIONS IN FORCE IN EVERY COUNTRY WHERE THE vehicle IS USED.**

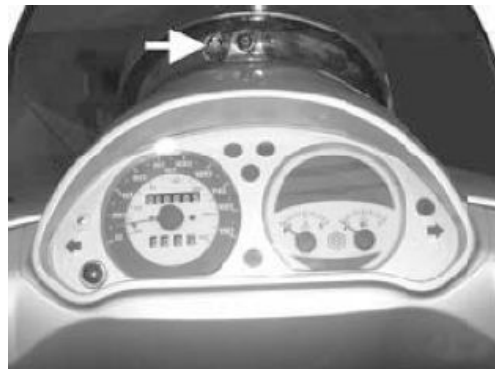

## Checking the end compression pressure

- Remove the spark plug cap when the engine is cold.
- Remove the ignition spark plug.
- Fit a compression test gauge into the spark plug seat using a 10 mm spark plug union at the proper tightening torque.
- Disconnect the revolution-timing sensor connector.
- Let the engine run using the starter and with the throttle body in fully open position as long as the gauge value is steady. If pressure is correct ( $> 11$  bar), remove the tool and reinstall the spark plug, the cap and the rev counter connector.
- If the pressure is less than indicated, check the rpm at which the test is carried out; if it is less than 450 rpm, check the starter system; if not, check the following:
  - Distribution timing
  - Valve clearance
  - Check valve seal
  - Check lining seal
  - Proper compression ratio selection

### Locking torques (N\*m)

#### Fitting for compression test 10

# INDEX OF TOPICS

ELECTRICAL SYSTEM

ELE SYS

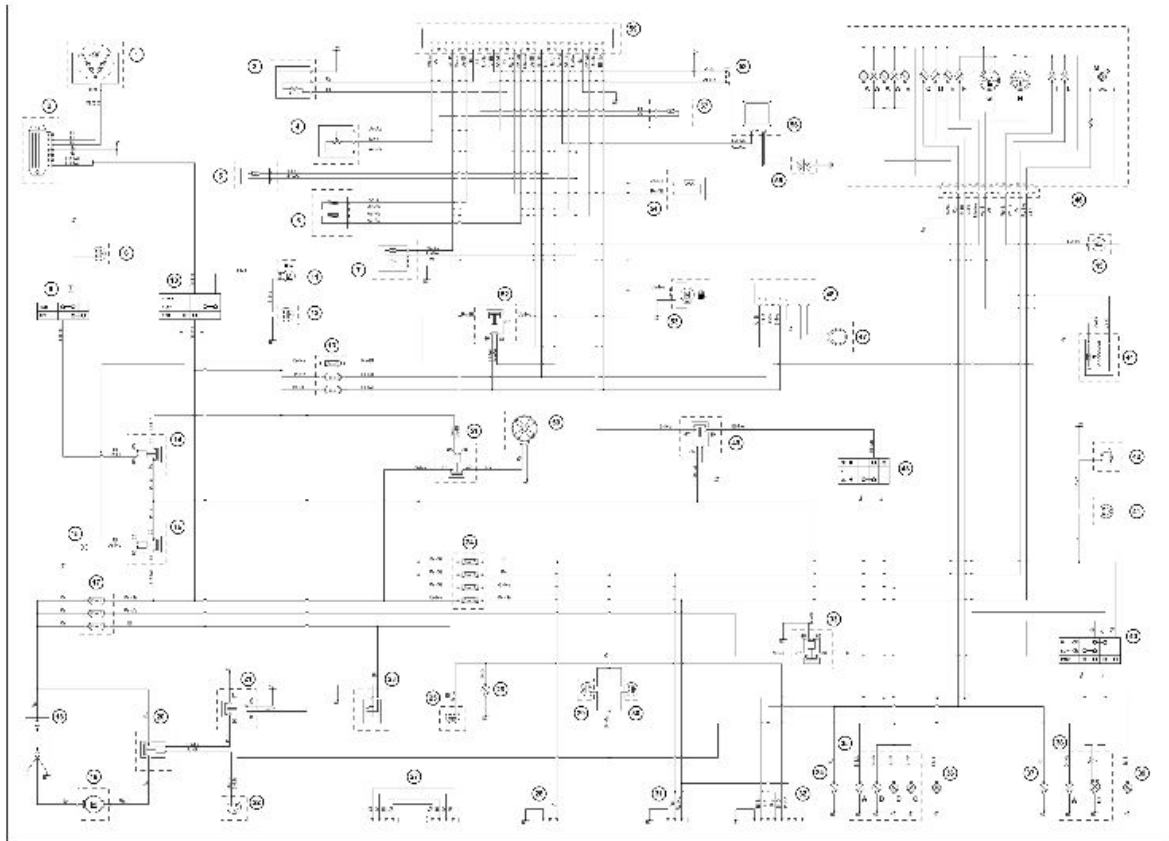

**LEGEND:**

1. Flywheel
2. Voltage regulator
3. Engine rev sensor
4. Throttle valve potentiometer
5. Air temperature sensor
6. Idle speed regulator
7. Engine temperature sensor
8. Centre stand push button
9. Engine stop switch
10. Key switch
11. Saddle opener actuator
12. Saddle opener push button
13. Fuse box
14. Engine stop remote control
15. Diode IA
16. Main remote control
17. Fuse box
18. Battery
19. Starter motor

- 20. Starter remote control
- 21. Immobiliser remote control
- 22. Starter push button
- 23. 12V 180W socket
- 24. Fuse box
- 25. Helmet compartment light switch
- 26. Helmet compartment light bulb
- 27. Preparation for radio intercom, display
- 28. Preparation for accessories
- 29. Left-hand stop push button
- 30. Right-hand stop push button
- 31. Preparation for radio intercom
- 32. Preparation for anti-theft device
- 33. Light remote control
- 34. Left rear turn indicator bulb
- 35. Rear light assembly
  - A. Stop light bulb
  - B. Tail light bulb
  - C. License plate bulb
- 36. Right rear turn indicator bulb
- 37. Left front turn indicator bulb
- 38. Front light assembly
  - A. Tail light bulb
  - B. Twin high-beam/low-beam bulb
- 39. Right front turn indicator bulb
- 40. Light switch
- 41. Horn button
- 42. Horn
- 43. Turn indicator switch
- 44. Fuel level sensor
- 45. Oil pressure sensor
- 46. Instrument panel
  - A. Instrument panel light
  - B. Headlight warning light
  - C. Left turn indicator warning light
  - D. Right turn indicator warning light
  - E. High-beam warning light
  - F. Engine Warning indicator light

- G. Fuel gauge
- H. Water temperature gauge
- I. Oil pressure warning light
- L. Fuel reserve warning light
- M. Immobiliser/diagnostic LED
- 47. Immobilizer aerial
- 48. Decoder
- 49. Turn indicator remote control
- 50. Electric fan
- 51. Electric fan remote control switch
- 52. Electronic control unit remote control
- 53. Fuel pump
- 54. Fuel injector
- 55. Spark plug
- 56. HV coil
- 57. Lambda probe
- 58. Diagnostic socket
- 59. Electronic control unit

**Ar** = Orange, **Az** = Sky Blue, **Bi** = White, **Bl** = Blue, **Gi** = Yellow, **Gr** = Grey, **Ma** = Brown, **Ne** = Black, **Ro** = Pink, **Rs** = Red, **Ve** = Green, **Vi** = Purple

#### CAUTION

**SHOULD ANY INTERVENTIONS TO THE ELECTRIC SYSTEM BE REQUIRED, MAKE SURE THAT THE LEADS TO THE ELECTRONIC IGNITION DEVICE ARE PROPERLY CONNECTED ACCORDING TO POLARITY AND TO THE LEAD COLOURS.**

## Components arrangement

### Component layout

#### Electronic control unit

In order to access the electronic control unit it is necessary to:

- Remove the front shield
- Remove the rubber protector of the electronic control unit remote control by loosening the three retaining screws
- Remove the remote control supporting bracket.

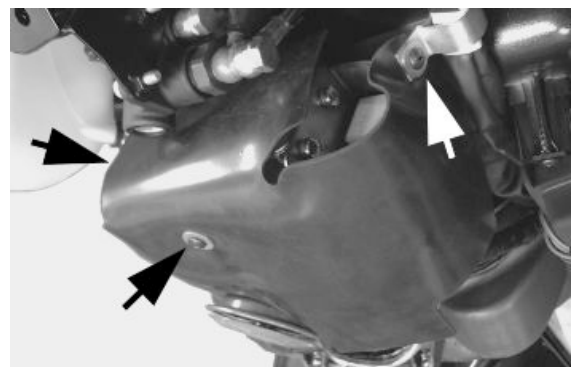

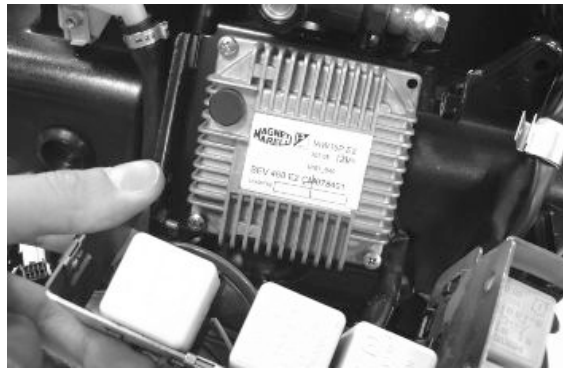
**Decoder**

In order to access the decoder, remove the front shield.

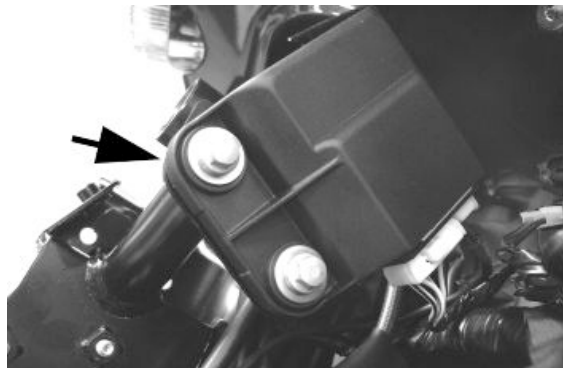
**Voltage regulator**

The voltage regulator is located in the upper part of the rear wheel compartment. To remove the regulator, loosen the two screws inside the helmet compartment.

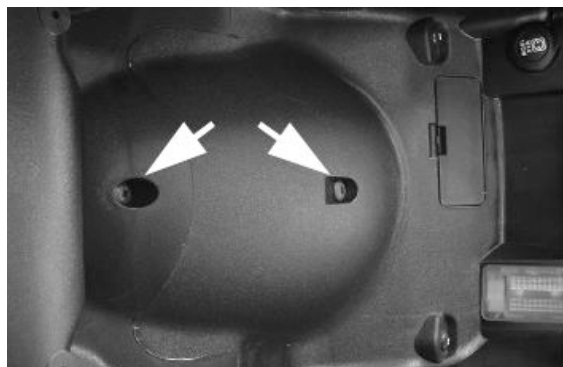

**HV coil**

To access the HV coil, remove the footrest on the left-hand side.

**Stand switch**

To access the stand switch, remove the footrest on the left-hand side.

**Lambda probe**

The lambda probe is mounted on the exhaust manifold

**Connectors and preparation****Diagnostic socket**

To access the diagnostic socket, remove the cover on the lower right side panel by loosening the screw.

The connector is attached to the cover.



**Antitheft connector**

To access the connector for the anti-theft system, remove the front shield.

The connector is located next to the decoder.

**Connector for radio intercom**

To access the radio intercom connectors A and B, remove the front cover.

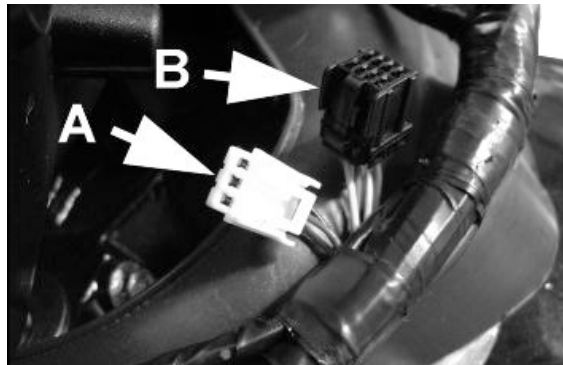
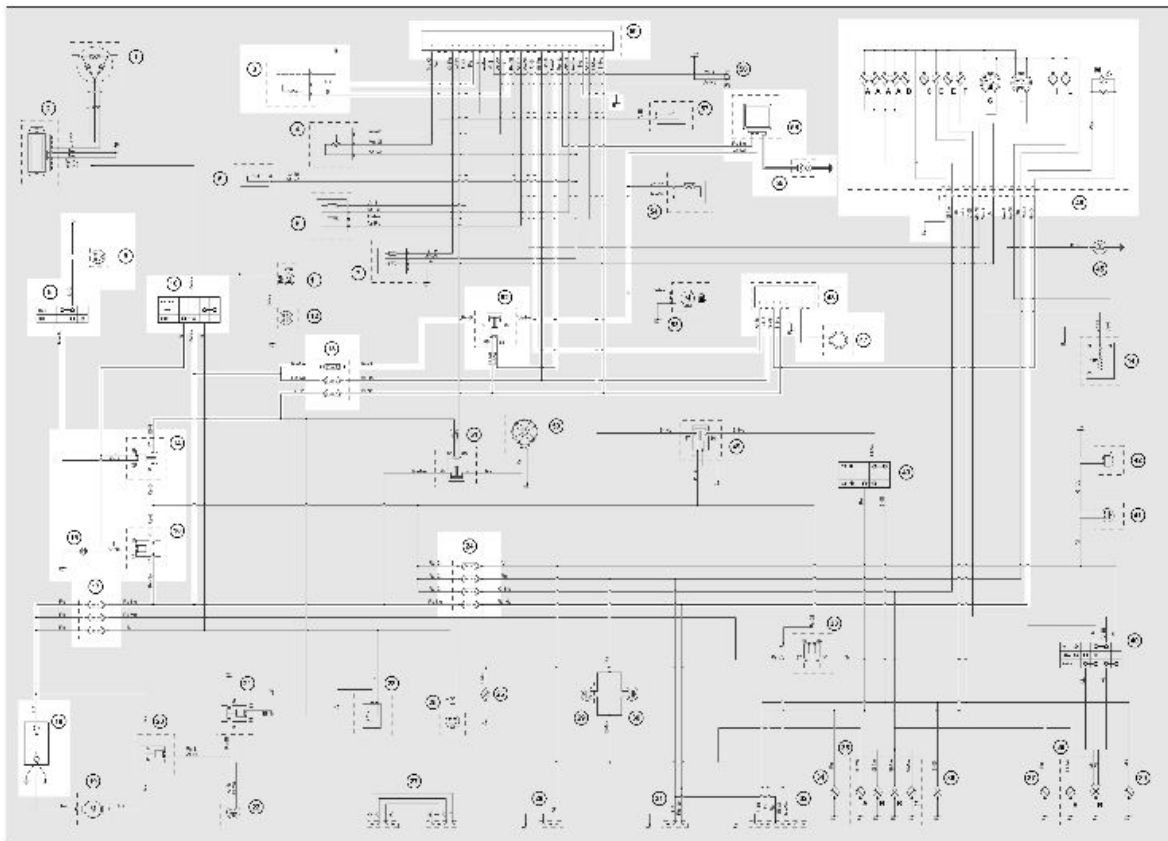
**Conceptual diagrams****Ignition**

**LEGEND:**

- 3.** Engine rev sensor
  - 8.** Stand push button
  - 9.** Engine stop switch
  - 10.** Key switch
  - 13.** Fuse box
  - 14.** Engine stop remote control
  - 15.** Diode IA
  - 16.** Main remote control
  - 17.** Fuse box
  - 18.** Battery
  - 24.** Fuse box
  - 46.** Instrument panel
    - A.** Instrument panel lights
    - B.** Lights warning light
    - C.** Left turn indicator warning light
    - D.** Right turn indicator warning light
    - E.** High-beam warning light
    - F.** Engine Warning indicator light
    - G.** Fuel gauge
    - H.** Water temperature gauge
    - I.** Oil pressure warning light
    - L.** Fuel reserve warning light
    - M.** Immobiliser/diagnostic LED
  - 47.** Immobilizer aerial
  - 48.** Decoder
  - 52.** Electronic control unit remote control
  - 55.** Spark plug
  - 56.** HV coil
  - 59.** Electronic control unit
-

## Battery recharge and starting

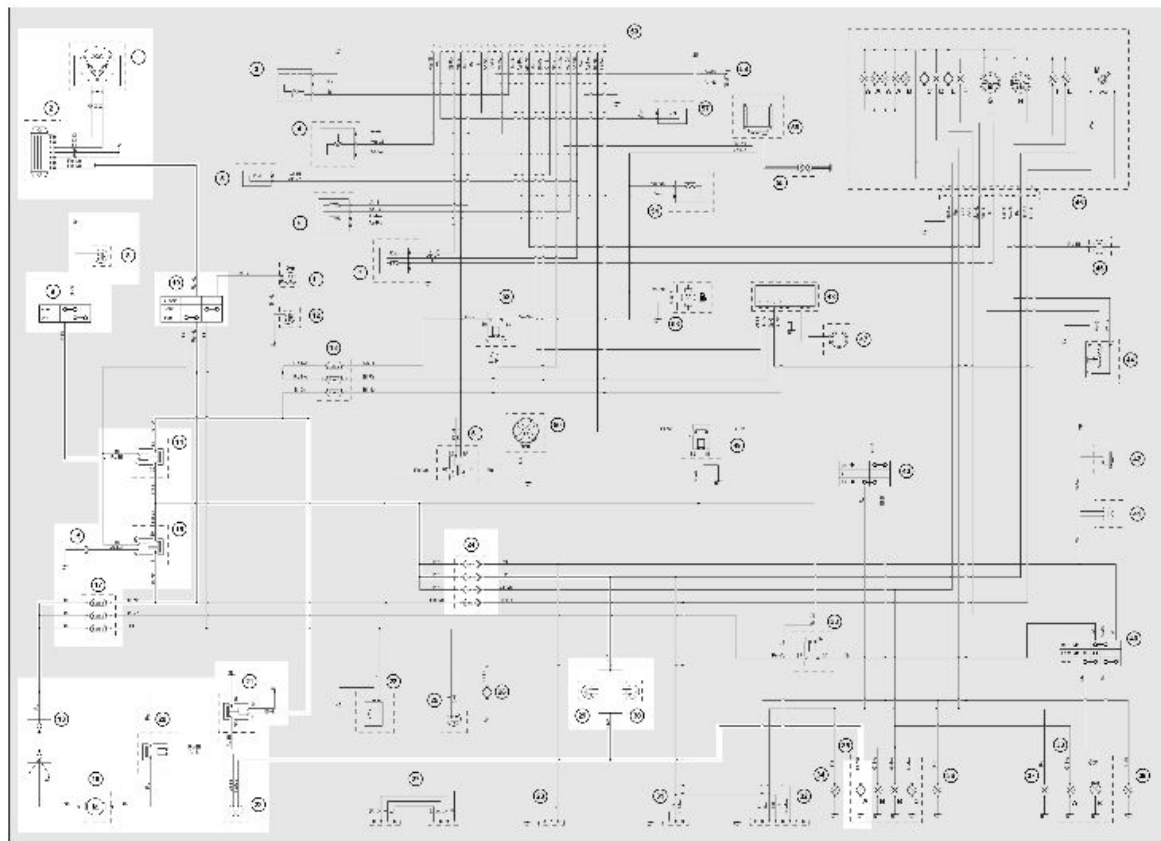

### KEY:

1. Flywheel
2. Voltage regulator
8. Stand button
9. Engine stop switch
10. Key switch
14. Engine stop remote control
15. Diode 1A
16. Main remote control
17. Fuse box
18. Battery
19. Starter motor
20. Starter remote control
21. Immobiliser remote control
22. Starter button
24. Fuse box
29. Left-hand stop push button
30. Right-hand stop push button



**35. Rear light assembly**

**A. Stop light bulb**

**Level indicators and enable signals section**

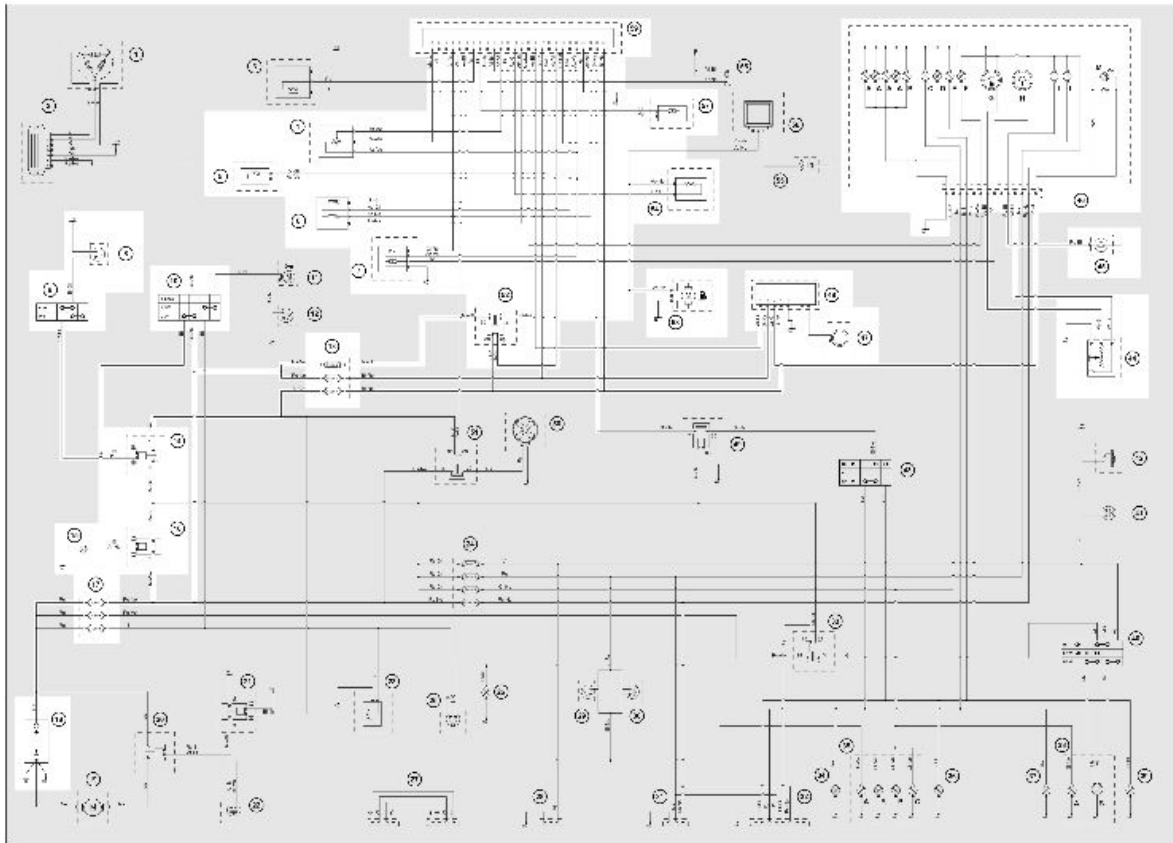

**LEGEND:**

- 4.** Throttle valve potentiometer
- 5.** Air temperature sensor
- 6.** Idle speed regulator
- 7.** Engine temperature sensor
- 8.** Stand push button
- 9.** Engine stop switch
- 10.** Key switch
- 13.** Fuse box
- 14.** Engine stop remote control
- 15.** Diode IA
- 16.** Main remote control
- 17.** Fuse box
- 18.** Battery
- 44.** Fuel level sensor
- 45.** Oil pressure sensor

- 46.** Instrument panel
    - A.** Instrument panel lights
    - B.** Headlight warning light
    - C.** Left turn indicator warning light
    - D.** Right turn indicator warning light
    - E.** High-beam warning light
    - F.** Engine Warning indicator light
    - G.** Fuel gauge
    - H.** Water temperature gauge
    - I.** Oil pressure warning light
    - L.** Fuel reserve warning light
    - M.** Immobiliser/diagnostic LED
  - 47.** Immobilizer aerial
  - 48.** Decoder
  - 52.** Electronic control unit remote control
  - 53.** Fuel pump
  - 54.** Fuel injector
  - 57.** Lambda probe
  - 59.** Electronic control unit
-

## Devices and accessories

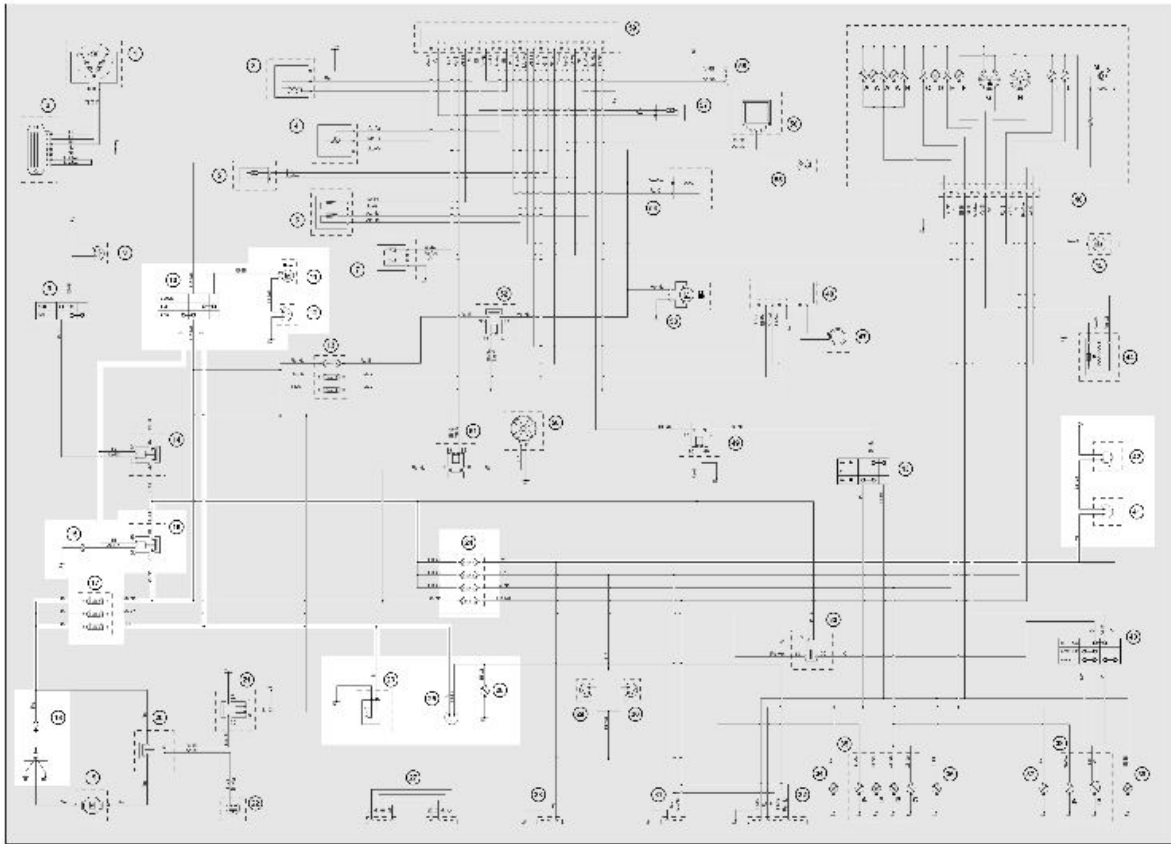
**LEGEND:**

- 10. Key switch
- 11. Saddle opener actuator
- 12. Saddle opening button
- 15. Diode IA
- 16. Main remote control
- 17. Fuse box
- 18. Battery
- 23. 12V 180W socket
- 24. Fuse box
- 25. Helmet compartment light switch
- 26. Helmet compartment light bulb
- 41. Horn button
- 42. Horn

## Lights and turn indicators

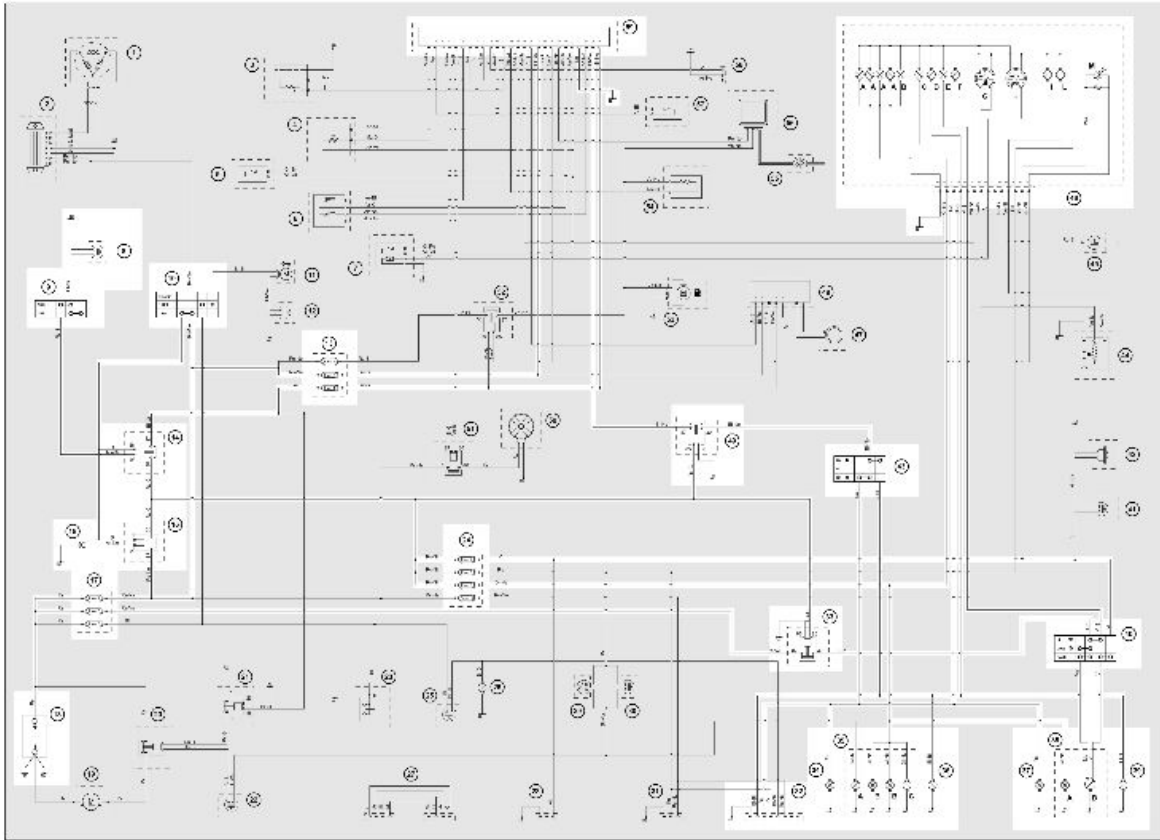

### LEGEND:

- 8. Stand push button
- 9. Engine stop switch
- 10. Key switch
- 13. Fuse box
- 14. Engine stop remote control
- 15. Diode IA
- 16. Main remote control
- 17. Fuse box
- 18. Battery
- 24. Fuse box
- 32. Preparation for anti-theft device
- 33. Light remote control
- 34. Left rear turn indicator bulb
- 35. Rear light assembly
- A. Stop light bulb
- B. Tail light bulb
- C. License plate bulb

- 36. Right rear turn indicator bulb
- 37. Left front turn indicator bulb
- 38. Front light assembly
  - A. Tail light bulb
  - B. Twin high-beam/low-beam lamp
- 39. Right front turn indicator bulb
- 40. Light switch
- 43. Turn indicator switch
- 46. Instrument panel
  - A. Instrument panel lights
  - B. Headlight warning light
  - C. Left turn indicator warning light
  - D. Right turn indicator warning light
  - E. High-beam warning light
  - F. Engine Warning indicator light
  - G. Fuel gauge
  - H. Water temperature gauge
  - I. Oil pressure warning light
  - L. Fuel reserve warning light
  - M. Immobiliser/diagnostic LED
- 49. Turn indicator remote control
- 59. Electronic control unit

---

## Checks and inspections

---

### Immobiliser

The electronic ignition system is controlled by the control unit with the integrated Immobilizer system. The immobilizer is an anti-theft system that allows the scooter to be operated only when it is started with coded keys recognised by the control unit. The code is integrated into a transponder inserted into the body of the key. This permits transparent operation for the rider who has to do no more than the normal turn of the key. The Immobilizer system consists of the following components:

- Control unit
- Decoder
- Immobilizer aerial
- Master key with integrated transponder (brown key)
- Service key with integrated transponder (black key)
- H.V. coil
- Diagnostic LED

The diagnostic LED also control the function of the immobiliser lamp. This function is activated every time the key switch is turned to position "OFF" or the emergency stop switch is turned to "OFF" and, in order not to prejudice the battery charge, remains active for 48 hours. When the key switch is turned to "ON", it interrupts the function of the immobiliser lamp and a start enable lamp comes "ON". The time for which this lamp stays on depends on the programming of the control unit. In the event that the LED goes out irrespective of the position of the key switch and/or the instrument panel is not initialised, check:

- Battery voltage is "ON"
- That none of fuses 1, 3, 4 or 10 has blown
- Power supply to the control unit as specified below:

Disconnect the connector from the control unit. Check the following conditions:

**With the key switch in position "OFF":**

- Battery voltage between terminals 17-23 and terminals 17-chassis ground (continuous power supply). In the event that there is no voltage, check that fuses 1 and 3 have not blown and check the corresponding wiring harnesses.

**With the key switch in position "ON" and the engine stop switch in "RUN":**

- Battery voltage between terminals 26-23 and terminals 26-chassis ground (continuous power supply). In the event that there is no voltage, check:
- The condition of fuse 4 and the corresponding wiring harness. The condition of the main remote control and the engine stop remote control
- Check for voltage on the blue/grey cable at the exit from the engine stop remote control. In the event that there is no voltage, check:
- The contacts of the key switch The condition of the engine stop switch, then for ground connection of the red/blue cable of the engine stop remote control The condition of the LED on the orange/black cable of the main remote control

If no fault is found, replace the control unit.

## Virgin circuit

When the ignition system is not encrypted, any key will start the engine but limited to 2000 rpm. The keys can only be recognised when the decoder has been correctly programmed. The procedure for programming a new decoder requires the recognition of the "master" key as the first key to be programmed: this is particularly important as it is the only key that allows the decoder to be reset

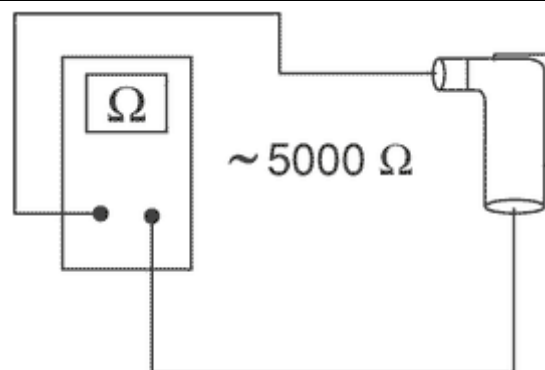

and reprogrammed for programming the service keys.

The master and service keys must be used to code the system as follows:

- Insert the Master key, turn it to «ON» and keep this position for two seconds (lower and upper limits 1 to 3 seconds).
- Insert the service key and turn it to «ON» for 2 seconds.
- If you have copies of the key, repeat the operation with each key.
- Insert the MASTER key again and turn it to «ON» for 2 seconds.

The maximum time to change keys is 10 seconds. A maximum of 7 service keys can be programmed at one time.

It is essential to adhere to the times and the procedure. If you do not, start again from the beginning. Once the system has been programmed, master key transponder, decoder and control unit are strictly matched. With this link established, it is now possible to encode new service keys, in the event of losses, replacements, etc. Each new programming deletes the previous one so, in order to add or eliminate keys, you must repeat the procedure using all the keys you intend to keep using. If a service key becomes uncoded, the efficiency of the high voltage circuit shielding must be thoroughly inspected: In any case it is advisable to use resistive spark plugs.

**Characteristic****MASTER key:**

BROWN KEY

**SERVICE key.**BLACK KEY

---

## Diagnostic codes

The immobiliser system is tested each time the ignition-key switch is turned from OFF to ON. During this diagnosis phase a number of control unit statuses can be seen and various light codes displayed. Regardless of the code transmitted, if at the end of the diagnosis the led remains off permanently, the ignition is enabled. If, however, the led remains on permanently, it means the ignition is inhibited:

**1. New decoder - key inserted:** a single 2 second flash is displayed, after which the LED remains off permanently. The keys can be stored to memory, the vehicle can be started but with a limitation imposed on the number of revs.

**2. New decoder - transponder missing or illegible:** The LED is permanently ON; in this condition, no operations are possible, including starting of the vehicle.

**3. Decoder programmed - service key inserted (normal operating condition):** a single 0.7-second flash is displayed, after which the LED remains off steadily. The engine can be started.

**4. Decoder programmed - master key inserted:** a 0.7-sec flash is displayed followed by the LED remaining off for 2 sec. and then by short 0.46-sec flashes the same number of times as there are keys stored in the memory including the Master key. When the diagnosis has been completed, the LED remains permanently OFF. The engine can be started.

**5. Decoder programmed - fault detected:** a light code is displayed according to the fault detected, after which the LED remains on steadily. The engine cannot be started. The codes that can be transmitted are:

- 1-flash code
- 2-flash code
- 3-flash code

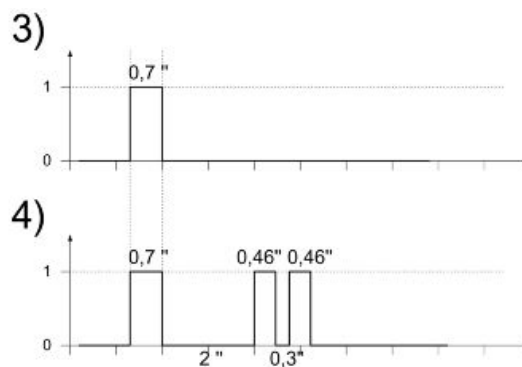
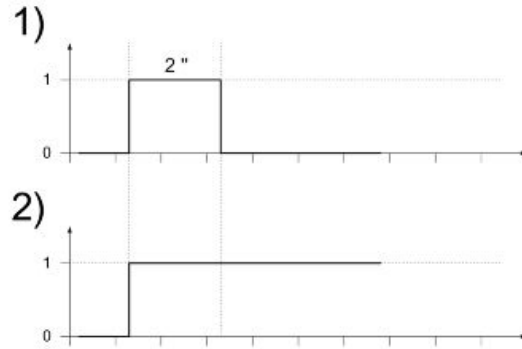



## Diagnostic code - 1 flash

A one-flash code indicates a system where the serial line is not present or is not detected. Check the Immobilizer aerial wiring and change it if necessary.

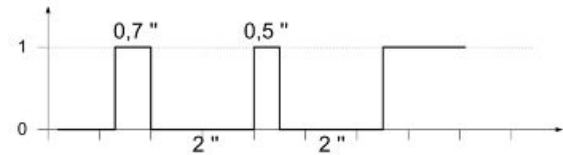

## Diagnostic code - 2 flashes

A 2-flash code indicates a system where the decoder does not recognise the transponder signal. This might depend on the inefficiency of the immobiliser aerial or the transponder.

Turn the switch to ON using several keys: if the code is repeated even with the Master key, check the aerial wiring and change it if necessary. Otherwise replace the faulty key and/or reprogram the decoder. If the problem persists, replace the decoder.

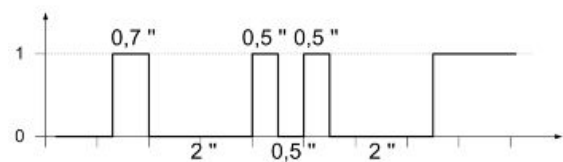

## Diagnostic code - 3 flashes

The 3-flash code indicates a system where the decoder does not recognise the key. Turn the switch to ON using several keys: If the error code is repeated even with the Master key, replace the decoder. If this is not the case, reprogram the decoder.

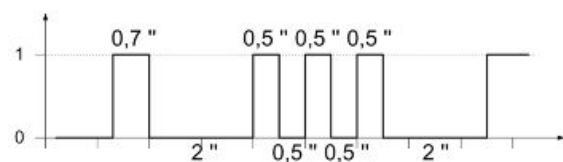

## Battery recharge circuit

The recharge system is provided with a three phase alternator with permanent flywheel. The alternator is directly connected to the voltage regulator.

This, in its turn, is connected directly to the ground and the battery positive terminal passing through the 30A protective fuse.

This system therefore requires no connection to the key switch.

The three- phase generator provides good recharge power and at low revs, a good compromise is achieved between generated power and idle stability.

---

## Stator check

### Stator winding check-up

#### WARNING

**THIS CHECK-UP CAN BE MADE WITH THE STATOR PROPERLY INSTALLED.**

- 1) Remove the right side panel.
- 2) Disconnect the connector between stator and regulator located next to the starter remote control.
- 3) Measure the resistance between each of the black terminals and the other two.

### Electric characteristic

#### Resistance:

0.2 - 1  $\Omega$

- 4) Ensure that each black cable is isolated from the earth.
- 5) If values are incorrect, replace the stator.

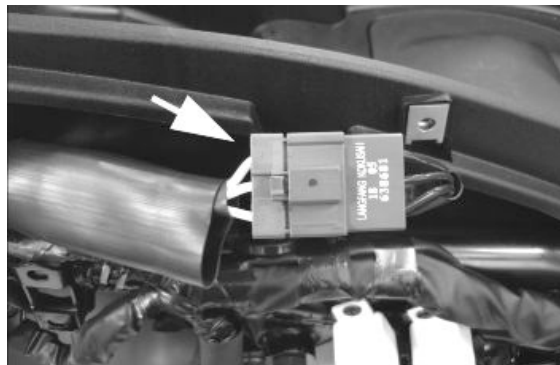

---

## Recharge system voltage check

### Look for any leakage

- 1) Access the battery by removing its cover under the saddle.
- 2) Check that the battery does not show signs of losing fluid before checking the output voltage.
- 3) Turn the ignition key to position OFF, connect the terminals of the tester between the negative pole (-) of the battery and the black cable and only then disconnect the black cable from the negative pole (-) of the battery.
- 4) With ignition key still at OFF, the reading detected by the amperometer must be  $\leq 0.5$  mA.

### Check the charging current

#### WARNING

**BEFORE CARRYING OUT THE CHECK, MAKE SURE THAT THE BATTERY IS IN GOOD WORKING ORDER.**

- 1) Place the vehicle on its centre stand
- 2) With the battery correctly connected to the circuit, place the tester terminals between the battery terminals..
- 3) Start the engine, ensure that the lights are all out, increase the engine speed and at the same time measure the voltage.

**Electric characteristic**

**Voltage ranging between 14.0 and 15.0V at 5000 rpm.**

**Maximum current output check.**

- With engine off and panel set to "ON" turn on the lights and let the battery voltage set to 12V.
  - Connect ammeter pliers to the 2 recharge positive poles in output from the regulator.
  - Keep the lights on and start the engine, bring it to normal speed and read the values on the ammeter.
- With an efficient battery a value must be detected: > 20A

**VOLTAGE REGULATOR/RECTIFIER**

Specification	Desc./Quantity
Type	Non-adjustable three-phase transistor
Voltage	14 ÷ 15V at 5000 rpm with lights off

**Turn signals system check**

The circuit of the turn signal indicators is supplied by the electronic control unit. In the event of a malfunction, proceed as follows:

1. Check the function of the bulbs
2. Check the function of the turn indicator remote control
3. Without disconnecting the electronic control unit, with the key switch in position "ON" and with the engine stop switch in position "RUN", check for intermittent voltage between terminal 25 and ground of the connection of the electronic control unit.
  - If there is no voltage, replace the electronic control unit.
  - If there is voltage, check for voltage on the blue/black cables of the remote control and on the turn indicator switch. If the light switch has voltage, replace the switch, otherwise the problem is to be found in the wiring between switch and remote control and between remote control and electronic control unit.

**Lights list**

The lighting system is supplied by three separate sections of the circuit:

1. Tail lights and instrument panel lights line, protected by fuse No. 9 and by the main remote control.
2. High-beam/low-beam front light assembly line, protected by fuse No. 6, by the main remote control and by the light remote control.

- 
3. High-beam headlight line in flashing mode (PASS), protected by fuse No. 7 and by the main remote control.
- 

### Tail lights and instrument panel lights line

In the event of a malfunction, check:

- Efficiency of the bulbs
- Efficiency of fuse No. 9
- With the main switch in position "ON", check for voltage on the red/yellow cable of fuse 9. Then check the wiring between main circuit breaker and fuse, and between fuse and lamp socket.

### High-beam/low-beam headlight line

In the event of a malfunction, check:

- The function of the twin bulb
- The function of fuse No. 6
- The function of the light switch in HI and LOW modes
- The function of the light remote control

With the main switch in position "ON", check:

- For voltage on the red/yellow cable and red/green cable of the light remote control.
- For voltage on the grey cable of the light remote control.
- The switch wiring and the contacts of the lamp socket.

### High-beam headlight line in flashing mode (PASS)

In the event of a malfunction, check:

- The function of the twin bulb
- The function of fuse No. 7
- The function of the light switch in PASS mode

---

## Fuses

The electrical system is equipped with:

- Six «A » fuses located inside the right-hand side fairing.



- Four «B» protection fuses for the different circuits of the electrical system located inside the glove-box on the top left-hand side of the helmet compartment.

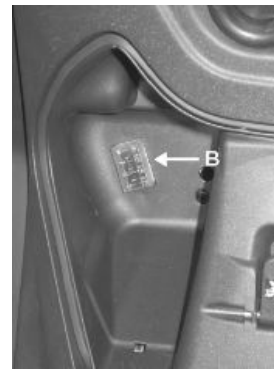

The tables show the position and characteristics of the fuses on the scooter.

**CAUTION**



**BEFORE REPLACING THE BLOWN FUSE, SEARCH AND SOLVE THE PROBLEM THAT CAUSED IT TO BLOW.**

**NEVER TRY TO REPLACE A BLOWN FUSE WITH A FUSE OF A DIFFERENT RATING THAN THAT SPECIFIED OR USING OTHER MATERIAL (FOR EXAMPLE, A PIECE OF ELECTRICAL WIRE).**

**FUSE HOLDER A**

	Specification	Desc./Quantity
1	1 - General	Fuse: 30 A
2	Injection load remote control	Fuse: 10 A
3	Direct power supply to electronic control unit and decoder	Fuse: 5 A
4	Permanent power supply to electronic control unit and decoder	Fuse: 5 A
5	Accessories: Socket 12V - 180W, helmet compartment light button, key switch contacts, saddle opener actuator, electric button opening.	Fuse: 15 A
6	Remote light control switch	Fuse: 10 A

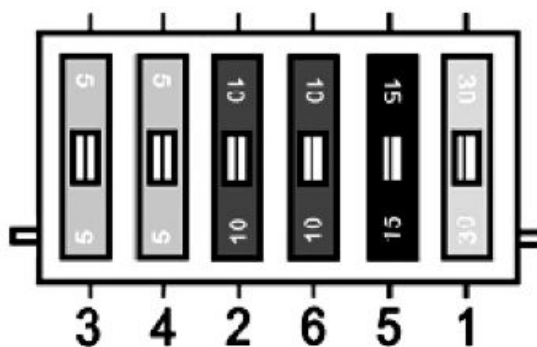

**FUSE HOLDER B**

	Specification	Desc./Quantity
1	Light flash, fitting for accessories, horn	Fuse: 15 A
2	Stop light, starter, radio and anti-theft system, damper, permanent power supply to instrument panel	Fuse: 7.5 A
3	Lamp for front and rear position light, license plate light, instrument panel lighting, lights indicator light	Fuse: 7.5 A
4	Immobilizer LED, radio/intercom fitting, anti-theft system	Fuse: 7.5 A

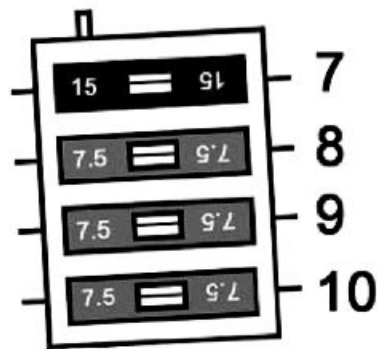

**Remote control switches**

The electrical system has eight remote control switches located in the area under the front shield and in the area under the right-hand fairing of the scooter:

To access the five remote control switches in the front area of the scooter, proceed as follows:

- Remove the front shield
- Remove the rubber protection of the electronic control unit remote control by loosening the three retaining screws

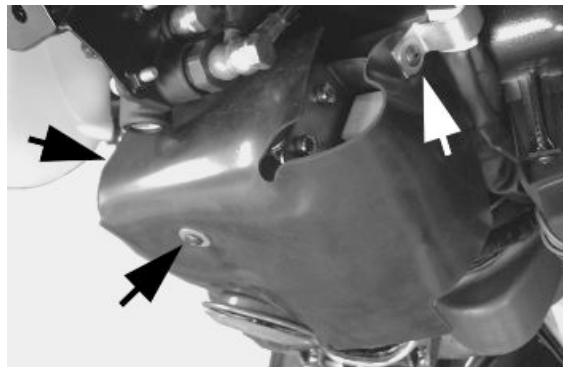

To access the remote control switches located in the rear area of the scooter, proceed as follows:

- Remove the right-hand side fairing
- To access the start-up remote control switch, unscrew the rubber support from its metal seat and then pull out the remote control switch



The following table shows the functions of each remote control switch:

Remote control switch	Description
A	Electric fan remote control
B	Turn indicator remote control
C	Immobiliser remote control
D	Main remote control
E	Light remote control

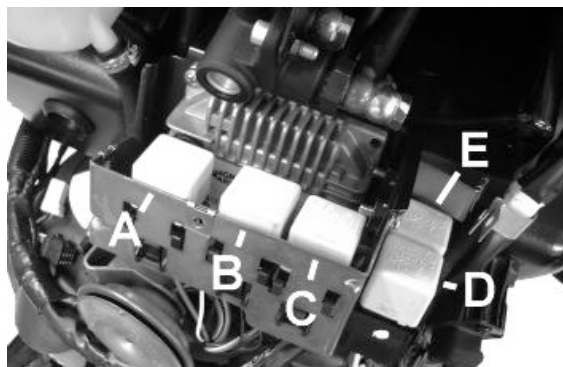

Remote	Description
<b>control switch</b>	
F	Electronic control unit remote control
G	Engine stop remote control
H	Starter remote control

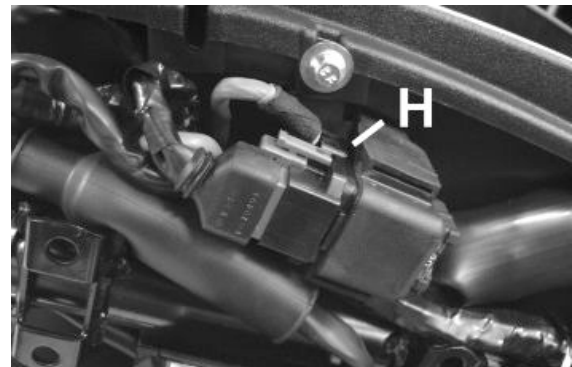
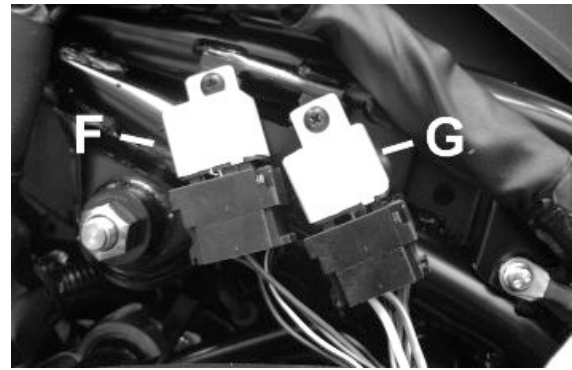

## Sealed battery

### Commissioning sealed batteries

If the vehicle is provided with a sealed battery, the only maintenance required is the check of its charge and recharging, if necessary. These operations should be carried out before delivering the vehicle, and on a six-month basis while the vehicle is stored in open circuit. Besides upon pre-delivery it is therefore necessary to check the battery charge and recharge it, if required, before storing the scooter and afterwards every six months.

### INSTRUCTIONS FOR THE RENEWAL RECHARGE AFTER OPEN-CIRCUIT STORAGE

#### 1. Voltage check

2.
  - Before installing the battery on the vehicle, check the open circuit voltage with a regular tester.
  - If voltage exceeds 12.60 V, the battery may be installed without any renewal recharge.
  - If voltage is below 12.60 V, a renewal recharge is required as explained at 2).

#### 3. Constant-voltage battery instructions

4.
  - Constant voltage charge equal to 14.40-14.70V
  - Initial charge current equal to 0.3-0.5 x rated capacity
  - Charge time:
    - 10 to 12 h recommended Minimum 6 h Maximum 24 h

#### 5. Constant-current battery charger mode

6.
  - Charge current equal to 1/10 of the battery rated capacity

## Dry-charge battery

### WARNING

THE BATTERY ELECTROLYTE IS POISONOUS AS IT MAY CAUSE SERIOUS BURNS. IT CONTAINS SULPHURIC ACID. AVOID CONTACT WITH THE EYES, THE SKIN AND CLOTHING. IF COMING INTO CONTACT WITH EYES OR SKIN, WASH ABUNDANTLY WITH WATER FOR APPROX. 15 MIN. AND SEEK IMMEDIATE MEDICAL ATTENTION.

IN THE EVENT OF ACCIDENTAL INGESTION OF THE LIQUID, IMMEDIATELY DRINK LARGE QUANTITIES OF WATER OR MILK, MAGNESIUM MILK, BATTERED EGG OR VEGETABLE OIL. SEEK IMMEDIATE MEDICAL ATTENTION.

THE BATTERIES PRODUCE EXPLOSIVE GAS; KEEP CLEAR OF NAKED FLAMES, SPARKS OR CIGARETTES; VENTILATE THE AREA WHEN RECHARGING INDOORS.

ALWAYS WEAR EYE PROTECTION WHEN WORKING IN THE PROXIMITY OF BATTERIES.

KEEP OUT OF REACH OF CHILDREN

- Remove the short closed tube and the caps, then pour sulphuric acid into the cells using the type specified for batteries with a specific gravity of 1.26, corresponding to 30 Bé at a minimum temperature of 15°C until the upper level is reached.
- Allow to stand for at least 2 hours, then top up the level with sulphuric acid.
- Within 24 hours, recharge using the special battery charger (single) or (multiple) at an intensity of about 1/10 of the battery nominal capacity and until the acid gravity is about 1.27, corresponding to 31 Bé and such values become steady.
- After charging, top up the acid (adding **distilled water**). Close and clean carefully.
- After carrying out the operations above, install the battery on the scooter, observing the connections described in point 3) of paragraph "**Battery re-charge**".

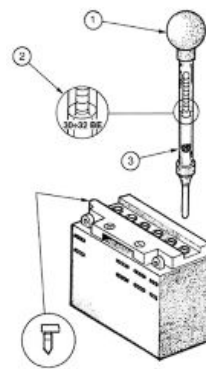

### Specific tooling

**020333Y Single battery charger**

**020334Y Multiple battery charger**

- 1 Keep the pipe in vertical position
- 2 Inspect visually
- 3 The float must be freed

### Checking the electrolyte level

The electrolyte level must be checked frequently and must reach the upper level. Only use distilled water, to restore this level. If it is necessary to add water too frequently, check the vehicle's electrical system: the battery works overcharged and is subject to quick wear.



**Charging status check**

After topping-up the electrolyte level, check its density using special density gauge.

When the battery is charged, you should detect a density of 30 to 32 Bé corresponding to a specific weight of 1.26 to 1.28 at a temperature of no lower than 15° C.

A density reading of less than 20° Bé indicates that the battery is completely flat and it must therefore be recharged.

If the scooter is not used for a given time (1 month or more) it will be necessary to periodically recharge the battery.

The battery runs down completely in the course of three months. When refitting the battery onto the scooter pay attention not to invert the cables, bearing in mind that the earth (**black**) wire marked with a (-) must be connected to the **negative** terminal whilst the other two **red** wires, marked with a (+) must be attached to the **positive**, + terminal.

**Battery recharge****WARNING**

**BEFORE RECHARGING THE BATTERY, REMOVE THE PLUGS OF EACH CELL. KEEP SPARKS AND NAKED FLAMES AWAY FROM THE BATTERY WHILE RECHARGING.**

Remove the battery from the vehicle removing the negative clamp first.

Normal bench charging must be performed using the special battery charger (single) or (multiple), setting the battery charge selector to the type of battery that requires recharging (i.e., at a current equal to 1/10 of the battery rated capacity). Connections to the power supply source must be implemented by connecting corresponding poles (+ to + and - to -).

**Specific tooling**

**020333Y Single battery charger**

**020334Y Multiple battery charger**

The battery should always be kept clean, especially on its top side, and the terminals should be coated with Vaseline.

**CAUTION**

**NEVER USE FUSES WITH A CAPACITY HIGHER THAN THE RECOMMENDED CAPACITY. USING A FUSE OF UNSUITABLE RATING MAY SERIOUSLY DAMAGE THE VEHICLE OR EVEN CAUSE A FIRE.**

**CAUTION**

**ORDINARY AND DRINKING WATER CONTAINS MINERAL SALTS THAT ARE HARMFUL FOR THE BATTERY. FOR THIS REASON, YOU MUST ONLY USE DISTILLED WATER.**

**CAUTION**

**CHARGE THE BATTERY BEFORE USE TO ENSURE OPTIMUM PERFORMANCE. FAILURE TO CHARGE THE BATTERY ADEQUATELY BEFORE BEING PUT INTO OPERATION WILL LEAD TO A PREMATURE FAILURE OF THE BATTERY.**

---

**Connectors**

---

## Dashboard

- The instrument panel is provided with two connectors (A with 8 pins and B with 6 pins) shown in the figure.

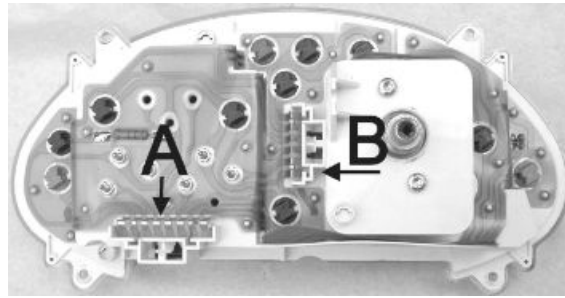

### CONNECTOR A

	Specification	Desc./Quantity
1	Left direction warning light	
2	Battery negative	
3	Battery positive	
4	Water thermometer	
5	Right direction warning light	
6	Preset indicator	
7	Fuel gauge	
8	Low fuel warning light	

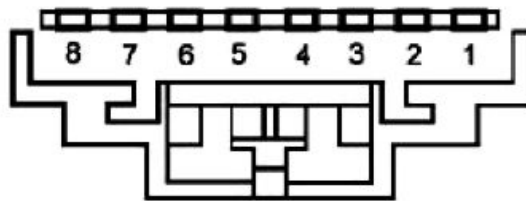

### CONNECTOR B

	Specification	Desc./Quantity
1	High-beam lamp warning light	
2	Ground lead	
3	Engine control warning light	
4	Engine oil pressure warning light	
5	+ battery under permanent power supply	
6	Instrument panel lighting and headlamp warning light	

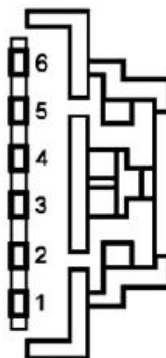

### FUEL GAUGE DAMPER

	Specification	Desc./Quantity
1	Fuel reserve warning light	
2	Fuel level gauge output	
3	Float input	
4	Test (not connected)	

---

	Specification	Desc./Quantity
5	Ground lead	
6	+ permanent power supply	

---

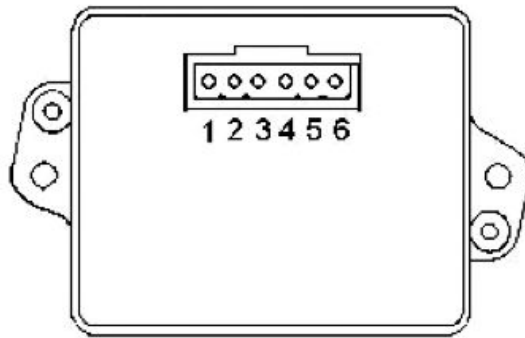

## INDEX OF TOPICS

ENGINE FROM VEHICLE

ENG VE

---

## Exhaust assy. Removal

---

- Undo the two exhaust manifold fixings on the head.



- Undo the three screws fixing the muffler to the support arm.
- Remove the full muffler unit.

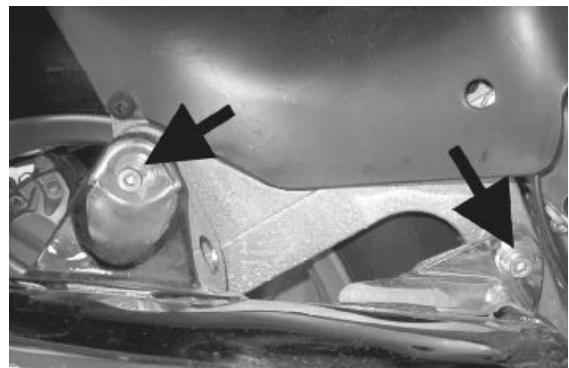

---

## Removal of the engine from the vehicle

### Scooter engine assembly

---

- Perform the operations for removal in the reverse order according to the tightening torque indicated in Chapter "Characteristics".

Check that there is a small clearance when the valve is in abutment against the set screw.

- Check the engine oil level and top up using the recommended brand, if required.
- Top up the coolant circuit.
- Check that throttle and electric devices are in good working order.

#### **CAUTION**

**PAY PARTICULAR ATTENTION TO POSITIONING THE THROTTLE CONTROL TRANSMISSION PROPERLY.**

---

- Disconnect the battery, remove the saddle and the fairings and drain the coolant.
- Remove the muffler and the relevant support and remove the rear wheel.
- Remove the swinging arm and the accelerator control transmission.
- Remove the air filter sleeve and the engine earth cable.
- Disconnect the carburettor electrical devices and the starter motor power supply cable.

- Disconnect the fuel delivery and return pipes from the carburettor and the cooling system piping (outlet from the head and inlet to the thermostat).
- Disconnect the spark plug H.V. cable and the alternator cables from the scooter electrical system.

**WARNING**

**CARRY OUT THESE OPERATIONS WHEN THE ENGINE IS COLD.**

**WARNING**

**BE VERY CAREFUL WHEN HANDLING FUEL.**

**CAUTION**

**WHEN INSTALLING THE BATTERY, ATTACH THE POSITIVE LEAD FIRST AND THEN THE NEGATIVE LEAD.**

---

## INDEX OF TOPICS

ENGINE

ENG

This section describes the operations to be carried out on the engine and the tools to be used.



## Automatic transmission

### Transmission cover

- Loosen the 4 fastening screws
- Extract the outside plastic transmission cover.



- Using a screwdriver, remove the driven pulley axle cover near the bottom of the cap.



- Loosen the driven pulley shaft fastening nut using a misaligned wrench and prevent the pulley shaft rotation using a machine hexagon bush.
- Remove the nut and the two washers.

**N.B.**

**DUE TO THE HIGH TIGHTENING TORQUE, USING DIFFERENT WRENCHES - SUCH AS A CONVENTIONAL POLYGONAL BUSH - MAY DAMAGE THE HEXAGON OBTAINED ON THE SHAFT OR BREAK THE BUSH ITSELF.**





- Remove the six M6 screws.



- Remove the four M8 screws.
- Remove the transmission cover.
- Check that the bearing rotates freely, otherwise replace it.



## Air duct

- Remove the transmission cover.
- Unscrew the two screws shown in the figure to remove the air conveyor.

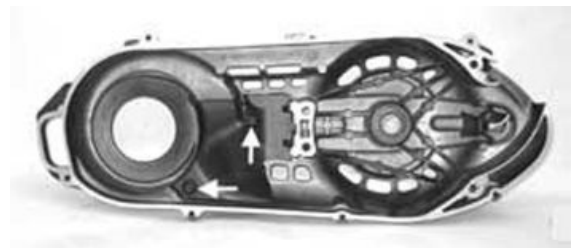

### Locking torques (N\*m)

**Air conveyor screws** 11 ÷ 12

- Remove the external transmission cover.
- Unscrew the 4 fastening screws shown in the figure to remove the external air conveyor.

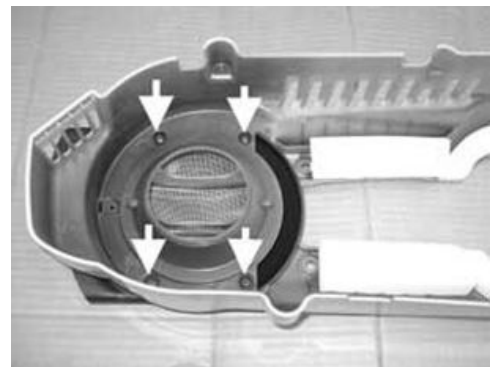

## Air duct filter

- Remove the external air conveyor.
- Unscrew the 2 fastening screws shown in the figure to remove the conveyor filter.



## Removing the driven pulley shaft bearing

- Remove the transmission cover.
- Remove the Seeger ring.



- Place transmission cover on a wood surface and use the special tool so that it is adequately supported.
- Pull out the bearing using the special tool.

### N.B.

**BELL MUST BE PLACED INTO THE TRANSMISSION COVER, CLOSE TO THE BEARING SEAT AND THE WOODEN SURFACE, SINCE WITHOUT BELL THE ENTIRE COVER STRUCTURE WOULD BEND. NOT ONLY IN THE AREA OF MAXIMUM STURDINESS.**



### Specific tooling

**001467Y002 Driver for OD 73 mm bearing**

**020376Y Adaptor handle**

**020375Y Adaptor 28 x 30 mm**

**020439Y 17 mm guide**

## Refitting the driven pulley shaft bearing

- Heat the transmission cover interior using the heat gun.

**N.B.**

**BE CAREFUL NOT TO OVERHEAT THE COVER AS THIS WOULD DAMAGE THE OUTSIDE PAINTED SURFACE.**

### Specific tooling

**020151Y Air heater**



- Place the bearing onto the special tool with a little grease to prevent it from coming out.

- Install the new bearing using the special tool.

**N.B.**

**PROPERLY SUPPORT THE OUTSIDE COVER TO PREVENT DAMAGING THE PAINTED SURFACE.**

### Specific tooling

**020376Y Adaptor handle**

**020358Y 37x40-mm adaptor**

**020439Y 17 mm guide**



## Baffle roller

## Plastic roller

### Installation of belt anti-vibration roller

- Install the anti-flapping roller with the lip facing the engine crankcase.
- Tighten the central screw to the prescribed torque.

**N.B.**

**TURN THE DRIVEN AND/OR DRIVING PULLEY UNTIL A CORRECT TENSIONING OF THE BELT IS OBTAINED.**

### Locking torques (N\*m)

**Anti-vibration roller screw 16.7 ÷ 19.6**

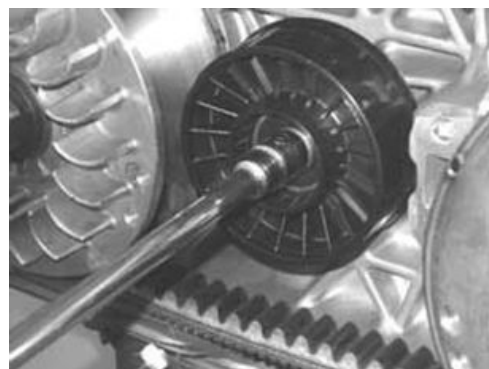

- Check that the roller does not show signs of wear and that it turns freely.
- Loosen the retaining bolt using a 13 mm spanner.
- Remove the complete roller with bearing.

**N.B.**

**IF THE ROLLER DOES NOT ROTATE FREELY, REPLACE THE COMPLETE ROLLER.**



## Removing the driven pulley

- Remove the driven pulley assembly with the belt.

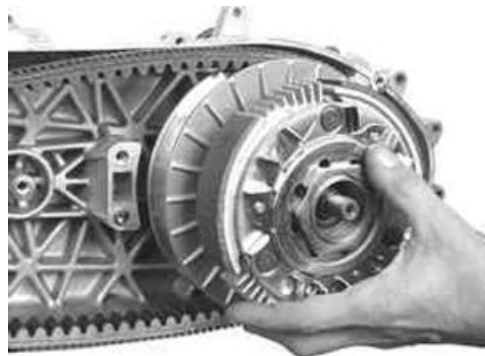

## Inspecting the clutch drum

- Remove the clutch bell.

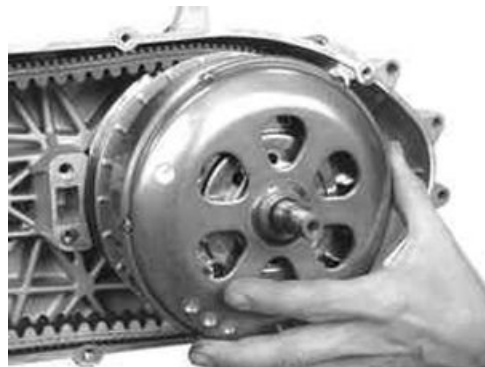

- Check that the clutch bell is not worn or damaged.
- Measure the clutch bell inside diameter.

**N.B.**

**CHECK THE ECCENTRICITY MEASURED, 0.2 MM MAX.**

### Characteristic

#### Max. value:

160.5 mm

#### Standard value:

160.2 mm



---

## Removing the clutch

- To remove the clutch with the driven pulley it is necessary to use the special tool;
- Arrange the tool with the mean pins screwed in position "E" on the inside;
- Install the driven pulley unit onto the tool inserting the pins into the ventilation holes;
- Move the rear stop screw in abutment against the fixed driven pulley as shown in the figure.



### CAUTION

**THE TOOL SHOULD BE FIRMLY SECURED IN A VICE USING THE SPECIAL TOOL. DO NOT TIGHTEN THE REAR SCREW TOO MUCH AS THIS COULD CAUSE AN IRREVERSIBLE TOOL DEFORMATION.**

**USING THE SPECIAL 55-MM WRENCH, REMOVE THE FASTENING RING NUT.**

**LOOSEN THE TOOL SCREW AND DISASSEMBLE THE DRIVEN PULLEY UNIT, CLUTCH, SPRING WITH SHEATH.**

### Specific tooling

**020444Y Tool for fitting/ removing the driven pulley clutch**

---

## Pin retaining collar

- Extract the collar using 2 screwdrivers.



- Remove the 4 guide pins.
- Extract the moving driven half-pulley.



## Removing the driven half-pulley bearing

- Check that the bushing is free from wear and damage; otherwise replace the fixed driven half-pulley.
- Remove the lock ring using pliers.



- Using the special tool inserted through the roller bearing, pull out the ball bearing.

**N.B.**

**PROPERLY SUPPORT THE PULLEY TO PREVENT DAMAGING THE THREADING.**

### Specific tooling

**020376Y Adaptor handle**

**020456Y Ø 24 mm adaptor**

**020363Y 20 mm guide**

**N.B.**

**IF YOU NEED TO OVERHAUL THE BEARINGS ON AN ASSEMBLED DRIVEN PULLEY UNIT, IT IS NECESSARY TO SUPPORT THE UNIT BY THE BELL**

### Specific tooling

**001467Y002 Driver for OD 73 mm bearing**

- Remove the roller bearing using the special tool, supporting the fixed half-pulley with the bell.

### Specific tooling

**020376Y Adaptor handle**

**020375Y Adaptor 28 x 30 mm**

**020364Y 25-mm guide**

**001467Y002 Driver for OD 73 mm bearing**



## Inspecting the driven fixed half-pulley

- Check that the belt contact surface is free from wear.
- Measure the outer diameter of the pulley bushing.

### Characteristic

#### Minimum admissible diameter

49.91 mm

#### Standard diameter:

50.00 -0.015 -0.035 mm



## Inspecting the driven sliding half-pulley

- Check that the belt contact surface is free from wear.
- Remove the 2 inside sealing rings and the 2 outside O-rings.
- Measure the movable half-pulley bushing inside diameter.

### Characteristic

#### Maximum admissible diameter:

50.05 mm

#### Standard diameter:

50.00 +0.035 0.00 mm



## Refitting the driven half-pulley bearing

- Install a new roller bearing using the special tool.

### N.B.

**PLACE THE BEARING WITH THE WRITINGS AND THE EMBEDDED OIL GUARD FACING OUTWARDS.**

- Properly support the half-pulley to prevent damaging the threading.

If you are working on the driven pulley unit fully assembled, use the special tool.

**Specific tooling****020478Y Punch for driven pulley roller casing****001467Y002 Driver for OD 73 mm bearing**

- Install a new ball bearing using the special tool.

**Specific tooling****020376Y Adaptor handle****020477Y Adaptor 37 mm****020363Y 20 mm guide**

- Insert the Seeger lock ring.

**Refitting the driven pulley**

- Insert the new oil guards
- Insert the new O-rings

**N.B.**

**O-RINGS ARE OF TWO SIZES. THE LARGE ONE IS INSTALLED ON THE MACHINING END RADIUS, AT THE BASE OF THE HALF-PULLEY.**

- Install the half-pulley on the bushing being careful not to damage the top sealing ring during the introduction.
- Make sure the pins and collar are not worn, re-assemble the pins and collar.



- Using a bent beak greaser, lubricate the driven pulley unit with about 10 gr. of grease, this operation should be carried out through one of the two holes into the bushing to obtain the exit of the grease from the opposite hole. This operation is necessary to avoid the presence of grease beyond the O-rings.

**Recommended products****AGIP GREASE SM 2 Grease for the tone wheel revolving ring**



---

Soap-based lithium grease containing NLGI 2 Molybdenum disulphide; ISO-L-XBCHB2, DIN KF2K-20

---

### Inspecting the clutch spring

---

- Measure the length of the spring, while it is relaxed.

**Characteristic**

**Standard length:**

125.5 mm

**Admissible limit after use:**

120 mm



- Check the thickness of the clutch mass friction material.

**Characteristic**

**Minimum thickness permitted:**

1 mm

- 
- The masses must exhibit no traces of lubricants; in that case, check the driven pulley unit seals.



**N.B.**

**UPON RUNNING-IN, THE MASSES MUST EXHIBIT A CENTRAL CONTACT SURFACE AND MUST NOT BE DIFFERENT FROM ONE ANOTHER. VARIOUS CONDITIONS CAN CAUSE THE CLUTCH TO TEAR.**

- Do not open the masses using tools to prevent a variation in the return spring load.
-

## Refitting the clutch

### Bell assembly

- Install the bell and the spacer.

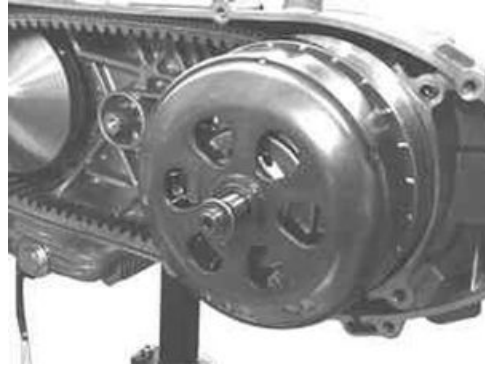

- Prepare the special tool as for removal;
- Preassemble the driven pulley unit with the drive belt according to its direction of rotation;
- Insert the driven pulley unit, the spring with sheath and clutch into the tool.

### Specific tooling

#### 020444Y Tool for fitting/ removing the driven pulley clutch



- Compress the spring and insert the clutch on the driven pulley bushing.

**N.B.**

**BE CAREFUL NOT TO DAMAGE THE SHEATH OR THE BUSHING THREADED END.**

- Tighten the ring nut by hand and complete the tightening using the special wrench to the prescribed torque.

### Specific tooling

#### 020444Y Tool for fitting/ removing the driven pulley clutch

### Locking torques (N\*m)

#### Clutch ring nut 65 - 75

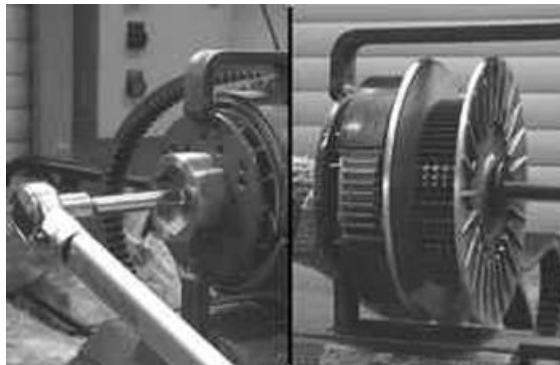

- To facilitate reassembly on the engine, turn the moving driven pulley and insert the belt onto the smaller diameter.

---

**Refitting the driven pulley**

---

- Install the driven pulley assembly with belt.



---

**Drive-belt**

---

- Check that the driving belt is not damaged.
- Check the width of the belt.

**Characteristic****Minimum width:**

25 mm

**Standard width:**

26.2 mm

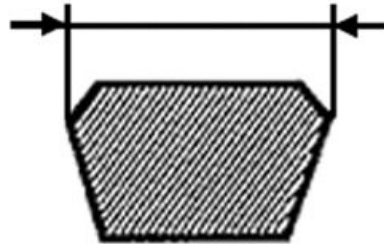

---

**Removing the driving pulley**

---

- Using a 27 mm wrench, turn the central pulley nut to horizontally align the central inside holes and install the special tool.

**Specific tooling****020474Y Driving pulley lock wrench**

- First install the lock ring of the special tool onto the pulley so that the splines are completely engaged.
- Then, insert the tool so as to insert the stud bolts on the ring into the holes obtained onto the tool itself.
- Tighten the two tool fastening nuts, also by hand.
- Loosen the central nut.
- Remove the spring washer and the flat washer.
- Remove the fixed driving half-pulley.
- Remove the bushing connection washer.

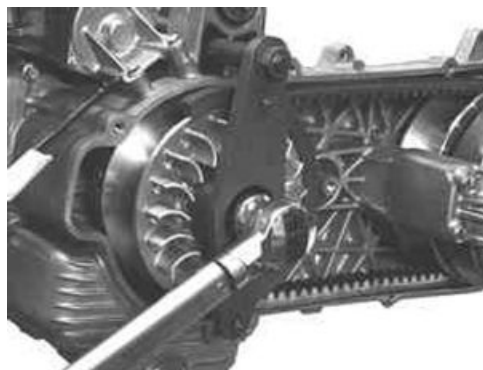

- Move the belt downwards.
- Suitable support the roller contrast and extract the mobile driving half-pulley with the relevant bushing and the rear washer, being careful not to make the rollers come out.



## Inspecting the rollers case

- Check that the inside bushings shown in the figure exhibit no signs of abnormal wear and measure the inside diameter.

### CAUTION

**DO NOT LUBRICATE OR CLEAN THE BUSHINGS**

#### Characteristic

**Maximum admissible diameter:**

30.12 mm

**Standard diameter:**

30.021 mm

- 
- Measure the pulley sliding bushing outside diameter shown in the figure.

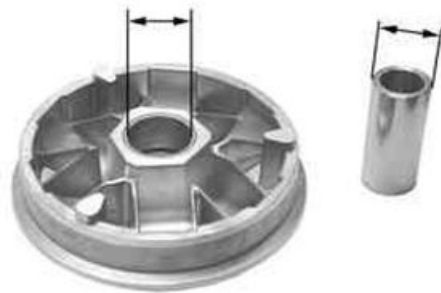

### Characteristic

#### Minimum admissible diameter

Ø 29.95 mm

#### Standard diameter:

Ø 29.959 mm

- Check that the rollers are not damaged or worn.

### Characteristic

#### Minimum admissible diameter

Ø 24.5 mm

#### Standard diameter:

Ø 24.9 mm

- 
- Check the guide shoes for the variator back-plate are not worn.
  - Check the wear of the roller housings and of the belt contact surfaces on both pulley halves.



## Refitting the driving pulley

### Installing the fixed driving half-pulley

- Insert the spacer.

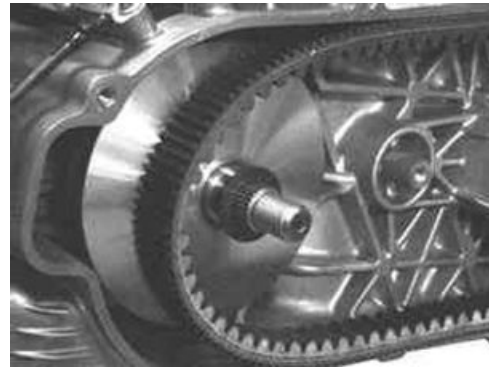

- Install the fixed driving half-pulley and check that it is in contact with the spacer and with the guide bushing of the moving driving pulley.



- Remove the flat washer and the spring washer as shown in the figure.



- Insert the nut in the original position (nut side in contact with the Belleville washer).



- Turn the central pulley nut to horizontally align the holes and install the special tool.

**N.B.**

**CHECK THAT THE STOP WRENCH TOOL IS EASILY INSERTED INTO THE PULLEY AND IN THE ENGINE CRANK-CASE.**

**Specific tooling**

**020474Y Driving pulley lock wrench**



- Install the lock ring from the rear so that the splines are completely engaged.
- Finally install the tool by sliding the nuts by hand and ensuring the tool is resting flatly.
- Tighten the driving pulley fastening nut to the prescribed torque
- Remove the special tool.

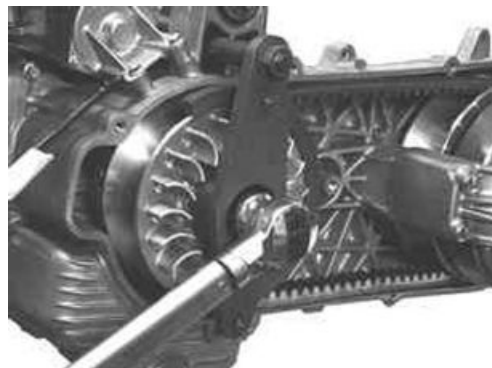

**Locking torques (N\*m)**

**Driving pulley nut 160 - 175**

**Installing the roller container**

- Install the spacer with the internal chamfer facing towards the inside.



- Position the rollers on the half-pulley as shown in the figure.
- The closed side must rest on the inside thrust face of the roller container.



- 
- Assembly the half-pulley with the roller contrast plate and sliding blocks.



- 
- Insert the half-pulley on the crankshaft.
  - Insert the spacer bushing.



---

## Refitting the transmission cover

- Ensure the correct installation on the crankcase of the 2 centring dowels.



- 
- Insert the transmission cover with the bearing and install the relevant retainers.
  - Lock the four M8 retainers.

### Locking torques (N\*m)

**M8 retainers for transmission cover 23 ÷ 26**





- Lock the 7 M6 retainers.

### Locking torques (N\*m)

M6 retainer 11 ÷ 13



- Insert the washers on the driven pulley shaft.

**N.B.**

**INSERT THE SMALLER WASHER FIRST, THEN THE LARGER ONE.**

- Insert the flanged nut.
- Prepare the torque wrench for LHS locking using a machine hexagon wrench.
- Tighten the driven pulley shaft fastening nut using an offset wrench.



**N.B.**

**DUE TO THE HIGH TIGHTENING TORQUE, USING DIFFERENT WRENCHES - SUCH AS A CONVENTIONAL POLYGONAL BUSH - MAY DAMAGE THE HEXAGON OBTAINED ON THE SHAFT OR BREAK THE BUSH ITSELF.**

### Locking torques (N\*m)

Driven pulley nut 92 - 100

- Install the driving pulley shaft cover, positioning the tooth gap on the lower part with the reference mark on the transmission crankcase.



**N.B.**

**ENSURE THAT THE AIR INTAKE AND EXHAUST OPENINGS ARE COMPLETELY FREE.**

- Install the outside plastic transmission cover.
- Tighten the 4 fastening screws to the prescribed torque.

**Locking torques (N\*m)****External transmission cover screws 7 ÷ 9**

---

**End gear**

---

**Removing the hub cover**

- Drain the rear hub oil through the oil drainage cap located under the engine.
- Drain the rear hub oil through the oil drainage cap located under the engine.
- Remove the 7 fastening screws. Remove the hub cover and the relevant gasket.



---

**Removing the wheel axle**

---

- Remove the countershaft.
- Remove the wheel axis complete with gear.

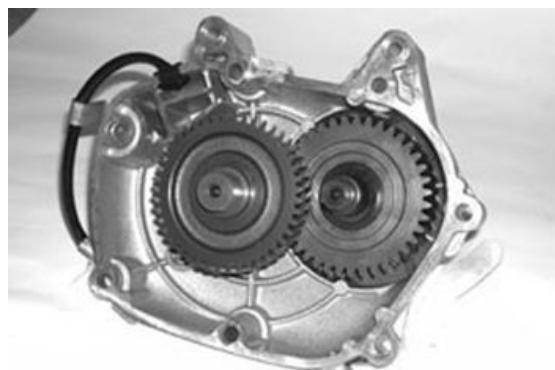

---

## Removing the hub bearings

- Support the hub cover using the column kit.
- Pull out the bearing using the special tool.

### Specific tooling

**020476Y Stud bolt set**

**001467Y006 Pliers to extract 20 mm bearings**

**001467Y007 Driver for OD 54-mm bearings**

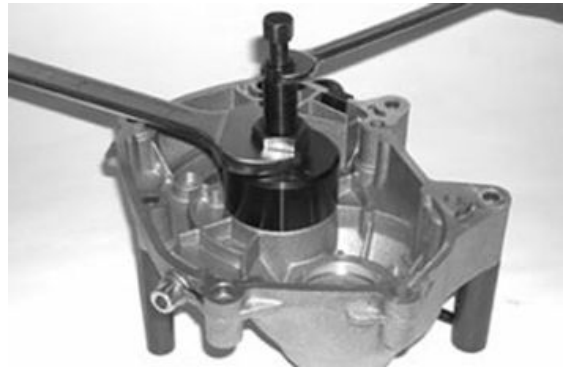

- 
- Check all bearings (wear, clearance and noise).  
In case of anomalies, proceed as follows.  
To remove the gear shaft bearing on the engine crankcase, use the following parts.

### Specific tooling

**001467Y014 Pliers to extract ø 15-mm bearings**

**001467Y034 Pliers to extract ø 15-mm bearings**

**001467Y031 Bell**



- 
- Use the special extractor to disassemble the bearing on the engine chassis of the countershaft.

### Specific tooling

**001467Y006 Pliers to extract 20 mm bearings**

**001467Y035 Belle for OD 47-mm bearings**

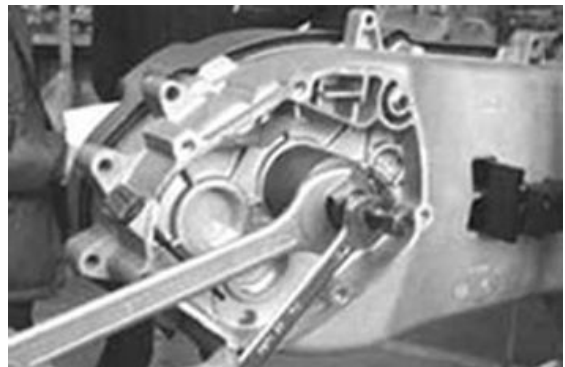

---

## Removing the wheel axle bearings

- Take out the clip on the outside of the gearbox cover.



- Support the hub cover using the column kit.
- Pull out the bearing using the special tool.

### Specific tooling

**020476Y Stud bolt set**

**020376Y Adaptor handle**

**020477Y Adaptor 37 mm**

**020483Y 30 mm guide**

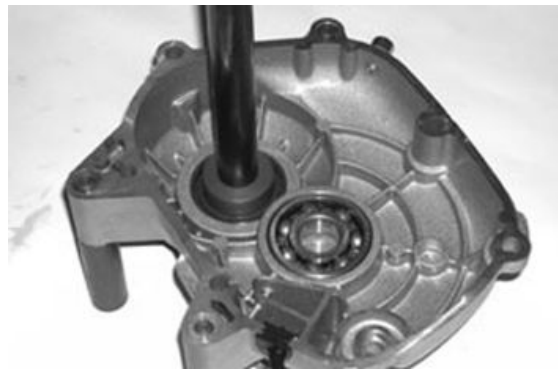

- Remove the oil guard using a screwdriver.



## Removing the driven pulley shaft bearing

- If you have to remove the driven pulley shaft, the relevant bearing and the oil guard, remove the transmission cover and the clutch unit as described in the Automatic transmission chapter.
- Extract the driven pulley shaft from its bearing.
- Remove the oil guard using a screwdriver into the hub gear box.
- Remove the Seeger ring shown in the figure.



- Pull out the driven pulley shaft bearing from the engine crankcase using the special tool.

### Specific tooling

**020376Y Adaptor handle**

**020358Y 37x40-mm adaptor**

**020364Y 25-mm guide**

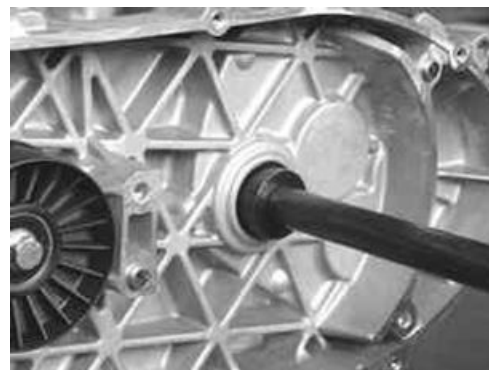

---

## Inspecting the hub shaft

---

- Check that the 3 shafts exhibit no wear or deformation on the grooved surfaces, at the bearings and at the oil guards.
- In case of faults, replace the damaged parts.

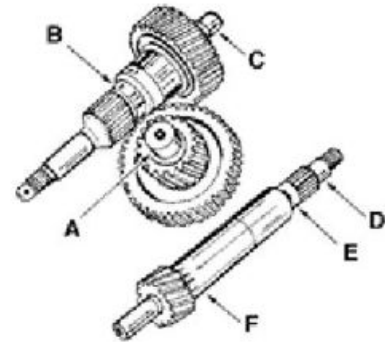

### Characteristic

#### Connection diameter for countershaft:

A = diameter 20 - 0.01 -0.02 mm

#### Connection diameter for wheel shaft:

B = diameter 30 - 0.010 -0.023 mm

C = diameter 15 - 0.01 -0.02 mm

#### Bearing diameter for driven pulley shaft:

D = diameter 17 - 0.01 -0.02 mm

E = diameter 20 - 0.01 -0.02 mm

F = diameter 25 - 0.01 -0.02 mm

---

## Inspecting the hub cover

- Check that the mounting surface is not damaged or deformed.
- Check the bearing bearings.

**In case of faults, replace the hub cover.**

---

## Refitting the driven pulley shaft bearing

- Heat the crankcase using the heat gun.

### Specific tooling

020151Y Air heater



- Insert the driven pulley shaft bearing until it abuts against the bottom of the seat using the special tool.

**N.B.**

PLACE IT WITH THE BALLS FACING THE HUB (THIS APPLIES TO BEARINGS WITH PLASTIC CAGE).

### Specific tooling

**020376Y Adaptor handle**

**020360Y Adaptor 52 x 55 mm**

**020364Y 25-mm guide**

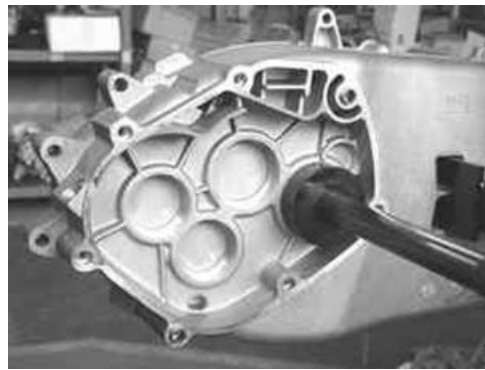

- Heat the intermediate gear bearing seat.
- Insert the intermediate shaft bearing using the special tool.

**N.B.**

PLACE IT WITH THE BALLS FACING THE HUB (THIS APPLIES TO BEARINGS WITH PLASTIC CAGE).

### Specific tooling

**020376Y Adaptor handle**

**020359Y 42x47-mm adaptor**

**020363Y 20 mm guide**



- Heat the gear shaft bearing seat on the crank-case.
- Insert the gear shaft bearing in the upper crank-case seat using the special tool.

**N.B.**

PLACE IT WITH THE BALLS FACING THE HUB (THIS APPLIES TO BEARINGS WITH PLASTIC CAGE).

### Specific tooling

**020376Y Adaptor handle**

**020359Y 42x47-mm adaptor**

**020412Y 15 mm guide**



- Place the safety lock Seeger ring of the driven pulley shaft bearing.

**N.B.**

PLACE IT IN THE POSITION SHOWN IN THE FIGURE.



- Insert the pulley shaft oil guard on the transmission side.

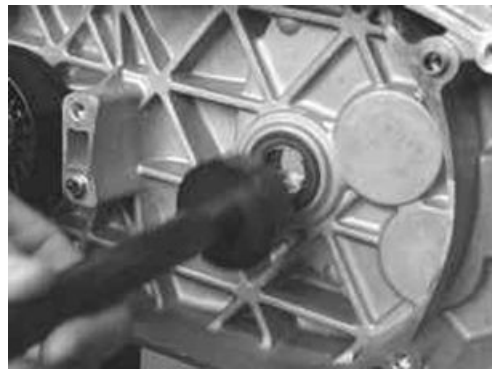

### Refitting the hub cover bearings

- Heat the bearing seats on the cover using the heat gun.
- Support the hub cover using the column kit.

#### Specific tooling

020151Y Air heater

020476Y Stud bolt set

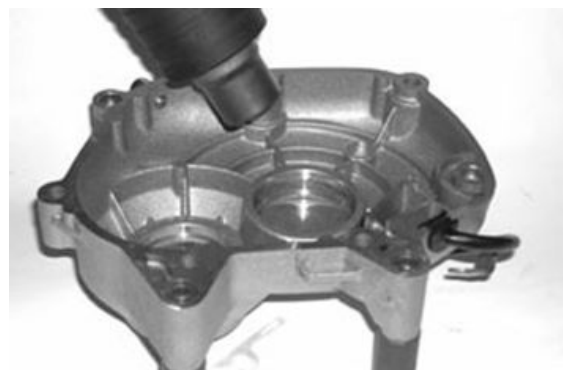

- Insert the intermediate shaft bearing on the cover using the special tool.

#### N.B.

PLACE IT WITH THE BALLS FACING THE HUB (THIS APPLIES TO BEARINGS WITH PLASTIC CAGE).

#### Specific tooling

020376Y Adaptor handle

020360Y Adaptor 52 x 55 mm

020363Y 20 mm guide



- Heat the gear shaft bearing seat from the cover outside.
- Insert the gear shaft bearing on the cover using the special punch until abutment.

#### Specific tooling

020376Y Adaptor handle

020360Y Adaptor 52 x 55 mm

020483Y 30 mm guide

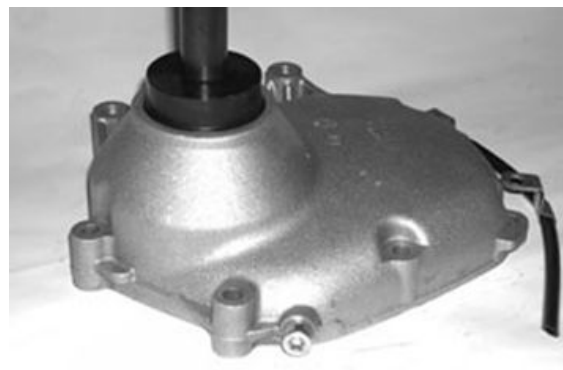

- 
- Replace the snap ring



- 
- Support the hub cover using the column kit.
  - Insert the wheel shaft oil guard with the sealing lip facing the inside of the cover.
  - Place the oil guard flush with the crankcase.



### Specific tooling

020376Y Adaptor handle

020360Y Adaptor 52 x 55 mm

020476Y Stud bolt set

---

## Refitting the hub bearings

- Place the 3 shafts as shown in the figure.



---

## Refitting the hub cover

- Check the proper position of the centring dowels.
- Install a new gasket.
- Fit the gearbox cover, making sure the breather pipe is in the correct position.

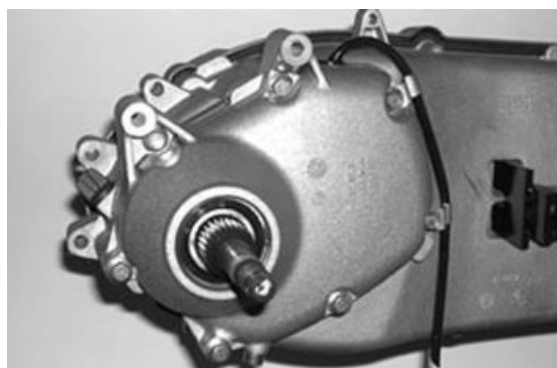



- Position the 7 set screws, tighten them to the prescribed torque, being careful of the position of the bands holding the vent tube, and the position of the 3 shortest screws as indicated in the figure.
- Refill with the prescribed oil to the Max. level.

### Recommended products

#### AGIP ROTRA 80W-90 rear hub oil

SAE 80W/90 Oil that exceeds the requirements of API GL3 specifications

### Characteristic

#### Quantity:

approx. 250 cc

### Locking torques (N\*m)

Rear hub cover screws 24 ÷ 27

---

## Flywheel cover

- Remove the three bands shown in the figure for an easier removal of the flywheel cover, remove the feed hoses and disconnect the return hose from the pump cover.

#### N.B.

THE BANDS MUST BE REPLACED. TO REMOVE THEM, OPEN WITH A SCREWDRIVER OR CUT THEM. BE CAREFUL NOT TO DAMAGE THE PLASTIC UNIONS.

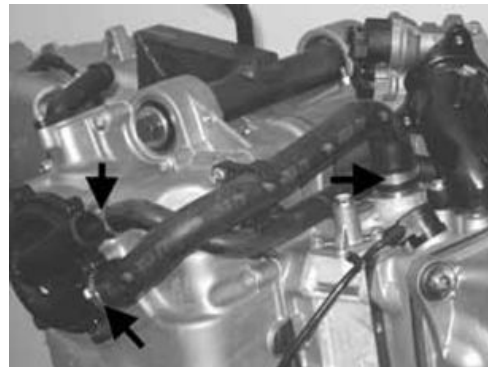

---

## Removing the hub cover

- Drain the engine oil by removing the drainage cap.
- Prepare a suitable container to collect the oil.



- 
- Remove the pre-filter.



- 
- Remove the oil filter using a filter tape or shaped cup wrench.



- 
- Loosen the 14 fastening screws.
  - Remove the flywheel cover with the relevant gasket and the cooling system sleeve support.

**N.B.**

THE SCREWS ARE OF 4 DIFFERENT LENGTHS. NOTE THE RELEVANT POSITIONS.

**CAUTION**

REMOVE THE COVER AVOIDING ANY POSSIBLE INTERFERENCE BETWEEN STATOR AND ROTOR.

**CAUTION**

BE CAREFUL TO PREVENT SLIPPAGE OF THE BY-PASS VALVE AND OF THE RELEVANT SPRING.

---

---

**Removing the flywheel cover components**

---

- Loosen the six mounting screws and remove the water pump cover.



- 
- Remove the by-pass and the relevant spring.
  - Remove the oil pump seal.



---

**Removing the stator**

---

- Remove the two retaining screws and the cable guide bracket.



- 
- Unscrew the 3 fastening screws and remove stator and its wiring.



---

- Loosen the two retaining screws and remove the reed valve support with bulkhead.

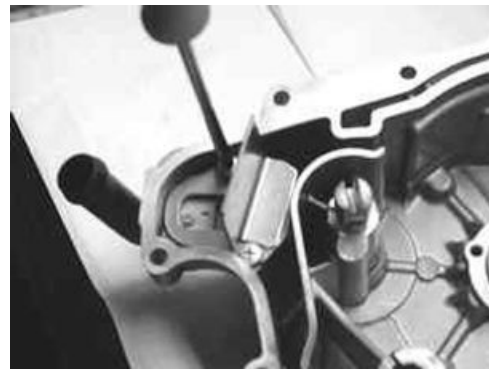

- Remove the blow-by reed valve with the relevant sealing gasket.



- Unscrew the fastening screw and remove the gas outlet union with the relevant O-ring.



- Remove the water pump impeller by unscrewing it from the relevant shaft.

**N.B.**

**THE THREADING IS CLOCKWISE. IT IS ADVISABLE TO PREVENT THE SHAFT ROTATION BY INSERTING A 12-MM WRENCH INTO THE DRIVE.**



- 
- Extract the shaft with the relevant abutment washer.



- 
- Remove the sealing ring.



- 
- Remove the ceramic ring and the relevant gasket.



- 
- Remove the sealing ring for the pump shaft lubrication using a suitably shaped tool.

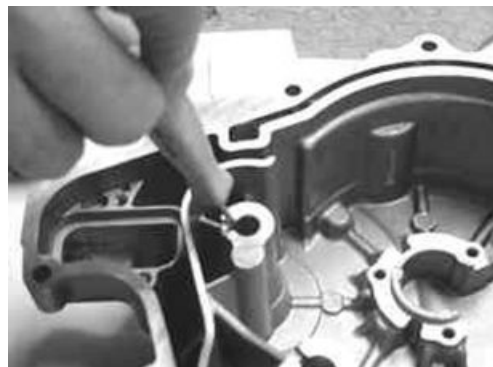

- Remove the engine oil filling cap/dipstick and the check hole cover for the distribution timing.
- Remove the minimum oil pressure sensor.



## Inspecting the cover components

- Install a new oil filter, lubricate the gasket, screw on and finally tighten to the prescribed torque.

### Locking torques (N\*m)

Engine oil filter 12 - 16



- Install the supply hose to the cylinder and connect the return hose to the pump cover using 3 new clamps.

### N.B.

**TIGHTEN THE CLAMPS USING APPROPRIATE PLIERS, PAYING ATTENTION NOT TO CONSTRICT THE HOSES BUT ALSO TAKING CARE TO TIGHTEN THE CLAMPS SUFFICIENTLY.**

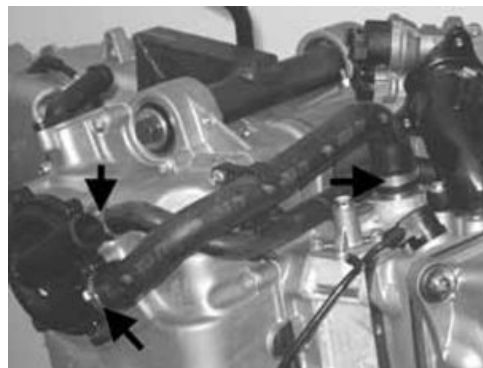

- Install the pre-filter again and insert the engine oil drain plug, tightening to the prescribed torque.
- Refill the engine with the prescribed type of oil.

### Recommended products

**AGIP CITY HI TEC 4T Engine oil**

SAE 5W-40, API SL, ACEA A3, JASO MA Synthetic oil

### Locking torques (N\*m)

Engine oil drainage plug 24 ÷ 30



- Check the condition of the stator and of the respective cable harness.



- Check the continuity between the 3 phases.

**N.B.**

**VALUES ARE STATED AT AMBIENT TEMPERATURE. A CHECK WITH THE STATOR AT OPERATING TEMPERATURE MAY RESULT IN VALUES HIGHER THAN THOSE STATED.**

**Electric characteristic**

**Resistance:**

0.2 - 1  $\Omega$



- Check the ground insulation of each phase.
- If a fault is found, carry out a thorough check of the cable harness that contains two types of cable: Rigid cables close to the stator and flexible cables close to the connector.



- Check that the winding is positioned so as not to interfere with the heads of the retaining screws.



- 
- Check that the mounting surface of the crankcase is not worn or deformed.
  - Check that the by-pass valve seat, the torque limiter and the water pump shaft are free from wear.

**Characteristic****By-pass housing hole diameter:**

13.9 mm

**Connection diameter for start-up gear shaft:**

12 mm

**Connection diameter for pump shaft:**

8 mm

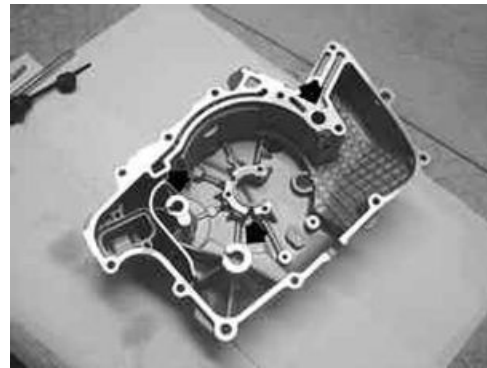

- 
- Check that the oil filter union and matching surface exhibit no deformations or wear.

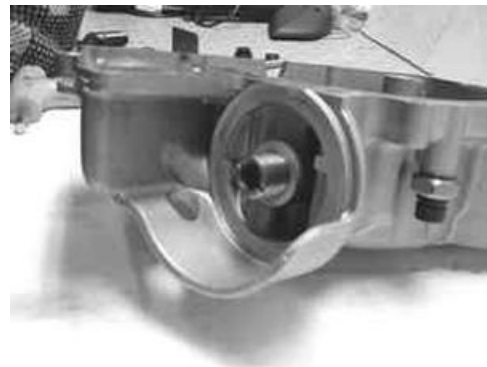

---

**Refitting the stator**

- Install the stator assembly together with the wiring harness, tightening the 3 screws to the prescribed torque.

**N.B.**

INSERT THE RUBBER WIRING SEALING GASKET INTO THE SPECIAL SEAT ON THE CRANKCASE.

**Locking torques (N\*m)****Stator retainers 8 - 10**



- Install the wiring guide bracket tightening the 2 screws to the prescribed torque.

### Locking torques (N\*m)

**Stator cable harness guide bracket screws 3 - 4**



- Temporarily install the distribution timing check hole cover and the engine oil filling cap/bar.
- Insert the blow-by recovery duct using a new O-ring.
- Tighten the screws to the prescribed torque.

### Locking torques (N\*m)

**Blow-by recovery duct fixing screws 3 - 4**



- Insert the spring and the by-pass piston on the flywheel cover.

**N.B.**

**LUBRICATE THE BY-PASS VALVE.**



## Refitting the flywheel cover components

- Before reassembling, check that all components are perfectly clean.
- For the cover, carefully check all lubrication channels, in particular:
  - The 3 by-pass channels.



- Oil feeding duct at the water pump shaft connection.



- Pump drainage duct.



- Oil pressure sensor feeding duct.



- Oil vapour decantation chamber

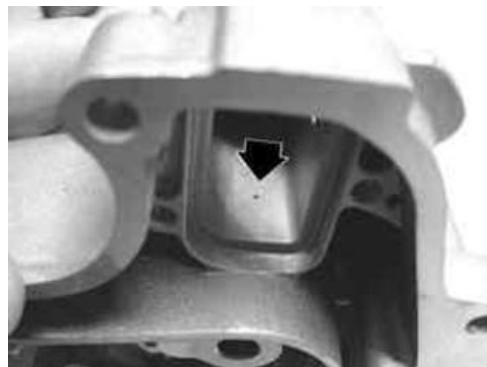

- Reinstall the blow-by reed valve using a new sealing gasket.
- Reinstall the support with head and tighten the screws to the prescribed torque.

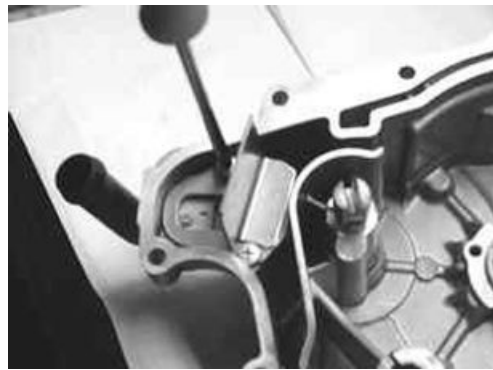

### Locking torques (N\*m)

**Supporting screws with bulkhead 0.3 - 0.4**

- Install a new sealing ring for the pump shaft using the special tool
- Install the oil minimum pressure sensor and tighten to the prescribed torque.



### Specific tooling

**020376Y Adaptor handle**

**020412Y 15 mm guide**

### Locking torques (N\*m)

**Minimum oil pressure sensor 12 ÷ 14**

- Pre-assemble the ceramic seal and the relevant gasket.

**N.B.**

**PLACE THE CHAMFERING TOWARDS THE GASKET BEING CAREFUL NOT TO FOUL THE CERAMIC RING WITH OIL OR GREASE, WHICH WOULD IMPAIR THE SEAL.**



- Insert the ceramic seal on the flywheel cover.

**N.B.**

**ASSEMBLE BY HAND TO PREVENT DAMAGES TO THE CERAMIC SEAL.**

- Insert the water pump shaft after lubricating the flywheel cover seat.
- Insert the mechanical seal on the shaft up to the impeller abutment surface.

**N.B.**

**THE FINAL INTRODUCTION DEPTH WILL BE DETERMINED BY THE IMPELLER.**

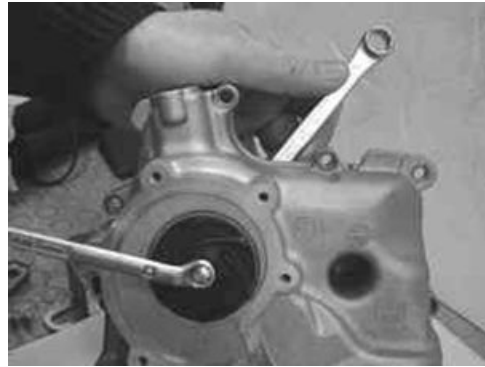

- 
- Screw the impeller and tighten to the prescribed torque.

**Locking torques (N\*m)****Water pump impeller 4 ÷ 5**

---

**Refitting the flywheel cover**

- Lubricate the intermediate gear seat with torque limiter on the flywheel cover.
- Align the water pump movement sensor with a reference and install the flywheel cover as described in the Flywheel cover chapter.



- 
- Install a new gasket on the engine crankcase.
  - Check the presence of the three centring dowels.



- 
- Turn the crankshaft in order to align the counter-shaft movement sensor with a reference point on the crankcase (see figure).



- Repeat the alignment for the water pump crankshaft using the same reference point on the engine.

**N.B.**

**THIS PREPARATION IS USEFUL PARTICULARLY IN THE EVENT OF REPAIRS WITH THE WATER PUMP COVER INSTALLED.**



- Install the flywheel cover on the engine, paying attention to avoid interference between the stator and rotor.

**WARNING**

**FAILURE TO OBSERVE THIS INSTRUCTION MAY RESULT IN DESTRUCTION OF THE CERAMIC MAGNETS.**

- Tighten the 14 retaining bolts of the cover to the prescribed torque.

**N.B.**

**THE BOLTS HAVE FOUR LENGTHS:**

- THE 3 SHORTEST ARE INSERTED AS SHOWN IN THE FIGURE.
- THE LONGEST IS INSERTED UNDER THE ENGINE OIL FILLER PLUG.

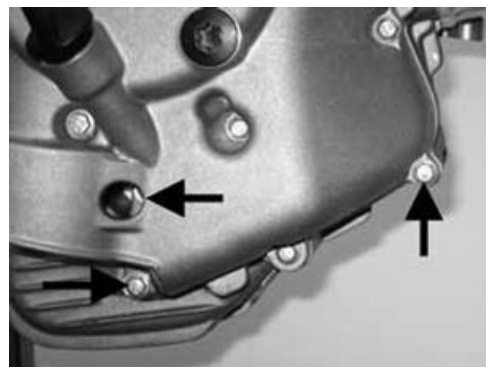

**N.B.**

- THE INTERMEDIATE BOLTS FOR THE REMAINING MOUNTING POINTS WITH THE EXCEPTION OF THE BOLT FOR THE MANIFOLD SUPPORT (SHOWN IN THE FIGURE) ARE SLIGHTLY LONGER.

**Locking torques (N\*m)**

**Flywheel cover screws 11 - 13**



**Flywheel and starting**

**STARTER MOTOR**

Specification	Desc./Quantity
Type	Mitsuba sm13d
Power	0.9 kW

**BATTERY**

Specification	Desc./Quantity
Capacity	14 Ah
Starting current	125 A

### **START-UP REMOTE CONTROL SWITCH**

Specification	Desc./Quantity
Type	SEALED
Maximum load	150 A continuous

### **STARTER TRANSMISSION**

Specification	Desc./Quantity
Ring gear and freewheel coaxial to the flywheel.	Intermediate gear with built-in torque limiter.

The starter system has a transmission between the motor armature and engine shaft equipped with freewheel coaxial to the flywheel and torque limiter on the intermediate shaft.

The limiter is calibrated to 10 kgm (100 Nm); this component protects the structure of the engine and the starter kinematic mechanism in the event of incorrect starting with consequent inverse rotations.

The freewheel is used for a sufficiently silent starting.

The starter control (energised remote control) is slaved to enabling signals by the side stand and the emergency OFF/RUN switch, which does not allow starting given dangerous conditions.

The starter control circuit is not controlled by the immobilizer system, therefore before insisting on the starter system, check the consensus of the immobilizer.

In order to check the enabling switches circuit, see the «Electrical system» chapter, whereas to check the engine shaft control transmission, follow what is described in the «Flywheel and starter system» chapter.

The starter is sold as a complete part.

Before deciding to replace it, carry out the following tests:

#### 1 - Battery

Check the voltage after not running (a few hours):

Voltage >12.5V

Check the density of the electrolyte of each cell:

$Bé = 30 \div 32$

Specific weight: 1.25 - 1.26

YES go to 2 NO go to 3

2 - Make sure the negative terminals (battery negative and starter negative) are correctly connected to each other and to the frame.

YES go to 4 NO go to 5

3 - Recharge and if necessary replace the battery.

4 - Connect the diagnostic tester (see chapter "Injection system").

Connect the induction clamp of an ammeter to the positive power supply cable of the starter motor.

Remove the 10A fuse no. 12 (see "fuses" chapter).

Switch in position "ON" with interrupt switch in position "RUN" and side stand raised.



Select the "PARAMETERS" function.

Start the engine (so that it cannot move) long enough to measure the rpm and starter absorption.

**N.B.**

**THE DECLARED RPM VALUE IS THAT INDICATED BY THE TESTER, THE RPM READING IS NOT THE REAL ONE, BUT IS VALID FOR DIAGNOSTIC PURPOSES.**

### **Specific tooling**

**020460Y Scooter diagnosis and tester**

#### **Electric characteristic**

##### **Absorption at trailing speed:**

80 - 120 A

##### **Revolution speed =**

approx. 300-400 rpm

YES go to 6 NO go to 7 NO go to 8 NO go to 9



5 - Restore the connections

**6- The values are correct.**

Finally carry out a check of the power consumption at idle speed.

Remove the starter motor (see the flywheel and starter system).

Reconnect the earth and positive and perform the test.

#### **Electric characteristic**

##### **Current consumption at idle speed:**

<40 A

YES go to 10 NO go to 11

**7- Low trailing speed**

##### **High electrical absorption**

Carry out a test of the engine rotation (example: possible melting of the bushes) and if no anomalies are found, replace the starter motor.

**8- Low trailing speed**

##### **Low electrical absorption**

Repeat the test, bridging the power terminals of the starter remote control switch or even better replacing them.

Check the new values.

YES go to 12 NO go to 13

**9** - High trailing speed

### **Low electrical absorption**

The engine turns too freely, check the compression end pressure.

If the values are not correct proceed as follows.

10 - The starter motor works properly.

11 - Check the rotation of the armature.

12 - Replace the starter remote control switch.

13 - Test the battery again and if necessary replace the starter motor.

**N.B.**

**IF THE TRAILING SPEED OF THE CRANKSHAFT IS LOW AND COMBINED WITH STRANGE NOISE, CHECK THE FREEWHEEL OF THE TORQUE LIMITER (SEE THE "FLYWHEEL AND STARTER SYSTEM" CHAPTER).**

- Remove the three bands shown in the figure for an easier removal of the flywheel cover, remove the feed hoses and disconnect the return hose from the pump cover.

**N.B.**

**THE BANDS MUST BE REPLACED. TO REMOVE THEM, OPEN WITH A SCREWDRIVER OR CUT THEM. BE CAREFUL NOT TO DAMAGE THE PLASTIC UNIONS.**

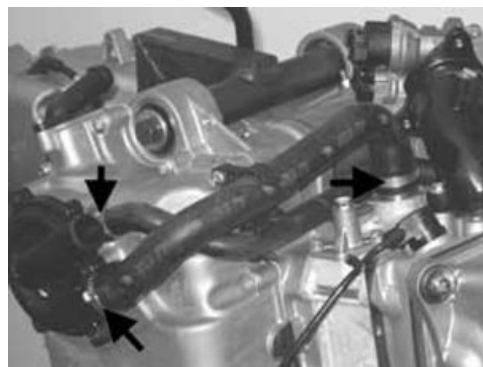

## **Removing the starter motor**

**N.B.**

**THIS OPERATION MAY ALSO BE CARRIED OUT WITH FLYWHEEL COVER ASSEMBLED.**

- Loosen the two fastening screws.
- Extract the complete starter motor.



## **Removing the flywheel magneto**

**N.B.**

**IF YOU MUST REMOVE THE FLYWHEEL, IT IS NECESSARY TO REMOVE THE CHAIN GUIDE SLIDING BLOCK RETAIN PLATE FIRST.**



---

- Unscrew the 3 fastening screws and remove the chain guide sliding block retain plate and the start-up rim.



---

- Align the holes obtained on the flywheel with the crankcase housing to allow the introduction of the special tool.

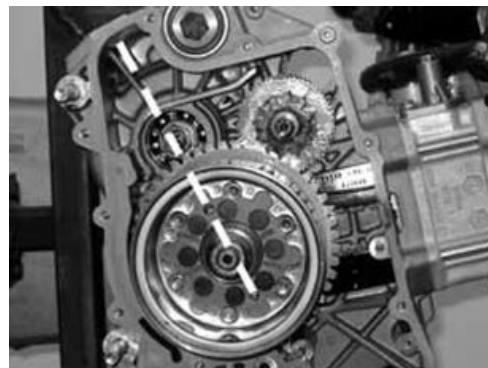

---

- Tighten the bushing of the flywheel lock tool on the removing tool threading.



---

- Insert the special tool as shown in the figure, making sure that the pins are perfectly inserted into the previously aligned holes and that it is perfectly abutted and almost flush with the flywheel.



## **Specific tooling**

**020472Y Flywheel lock wrench**

- Loosen the magneto flywheel fastening nut.
- Remove the special tool and the fastening nut.

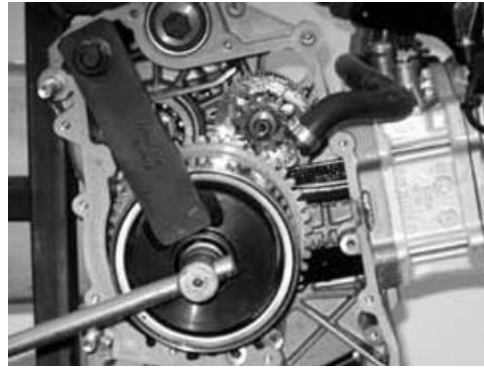

- Remove the washer.



- Insert the nut again so as to slightly uncover the shaft and free the space that was occupied by the washer.

**CAUTION**

THIS OPERATION IS REQUIRED AS THE FLYWHEEL IS STRONGLY LOCKED; THE CONE DETACHMENT MAY THEREFORE CAUSE THE ROTOR SLIPPAGE, WITH THE CONSEQUENT BREAKAGE OF THE MAGNETS.



- Insert the special removing tool.
- Using a 27-mm wrench and a 19-mm bushing, release the flywheel.

**Specific tooling**

**020467Y Flywheel extractor**



- Remove the extractor.
- Remove the nut and extract the flywheel with the start-up rim.
- Remove the crankshaft key.



- To remove the start-up rim from the freewheel it is necessary to turn it clockwise and pull it out.



- Remove the freewheel from the flywheel by loosening the 6 fastening screws.

**SINCE THE FREEWHEEL MUST BE REMOVED, IT IS ADVISABLE TO LOOSEN THE 6 FASTENING SCREWS IN ADVANCE WITH THE FLYWHEEL STILL INSTALLED ON THE CRANKSHAFT.**



- The freewheel is coupled to the flywheel with high precision; if removal is difficult, use 2 screws as gripping points and as removing tools, if required.



- Extract the intermediate gear provided with torque limiter.

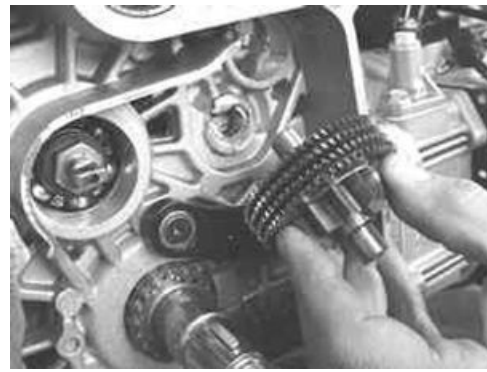

## Inspecting the flywheel components

- Check the integrity of the magnets.
- Check that the magnet support cage is free from deformation or cracks.
- Check that the flywheel splines exhibit no loosening.



## Starter gear rim

- Check that there is no wear or abnormal impressions on the "rollers" of the freewheel and on the surface of the starter ring gear hub.
- Check the hub outside diameter.

### Characteristic

#### Hub outside diameter:

Diameter  $45.665 + 0.008 + 0.005$  mm

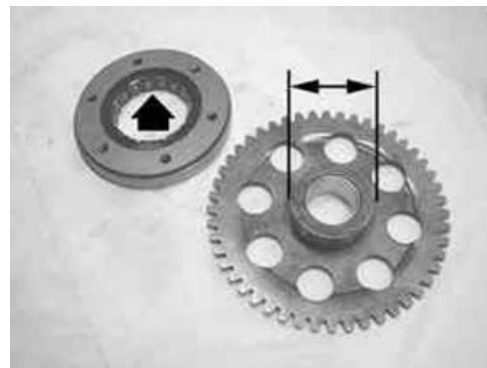

- Check the inside diameter of the bushing of the starter gearing.
- Check that the tothing is not worn.

### Characteristic

#### Inside diameter of the bushing:

Diameter  $27 + 0.020 + 0.041$  mm



N.B.

IF THE FAULTS DISCOVERED AFFECT THE HUB, REPLACE THE STARTER RING GEAR AND FREEWHEEL.

IF ONLY THE BUSHING IS WORN, IT IS POSSIBLE TO REPLACE ONLY THE COMPLETE START-UP RIM. IN THAT CASE, CHECK ALSO THE DIAMETER AND THE SURFACE OF THE CONNECTION ON THE CRANKSHAFT. IN CASE OF IRREGULARITIES, REPLACE THE CRANKSHAFT.

### Intermediate gear

- Check that the tothing is not worn.
- Check the diameter of the two bearings.

#### Characteristic

##### Gear bearing diameter:

12 - 0 0.011 mm

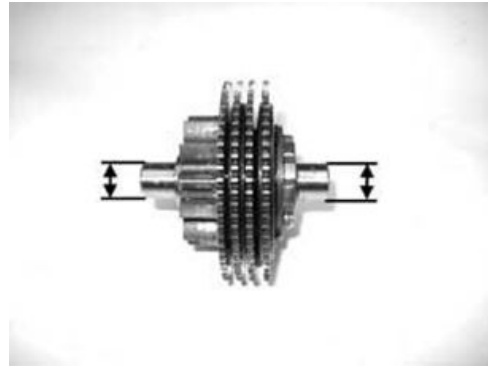

Also check the shaft diameter on the flywheel cover and on the engine crankcase.

#### Characteristic

##### Bearing diameter on the flywheel cover

12 + 0.034 -0.016 mm

##### Bearing diameter on the engine crankcase:

12 + 0.034 -0.016 mm

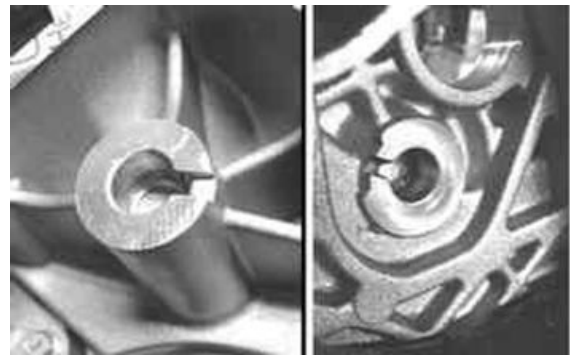

#### N.B.

**THE TORQUE LIMITER IS PROVIDED WITH 4 GEARS THAT HAVE THE FUNCTION OF CLUTCH DRIVE PLATES.**

Driven plates consist of 4 Belleville springs provided with grooved profiles; this assembly allows transmitting torque lower than 10 kgm.

In case of incorrect start-up manoeuvres, the limiter prevents any kicks, with consequent reversal of direction of the crankshaft which would impair the engine structure.



The limiter assembly cannot be overhauled. In case of irregularities on the toothed discs, replace the assembly.

### Refitting the free wheel

- Make sure the freewheel faying surfaces are in good condition.
- Thoroughly clean the free wheel to remove LOCTITE residue.

- Degrease the threading of the holes in the free wheel and the clamping screws.
- Apply the recommended product to the end of the screws.

### Recommended products

#### Loctite 243 Medium strength threadlock

Loctite 243 medium-strength threadlock

---

- Fit the freewheel on the magneto flywheel making sure that the ground side is in contact with the flywheel itself, i.e. with wheel seeger ring visible.
- Lock the six clamping screws in criss-cross fashion to the prescribed torque.



### Locking torques (N\*m)

#### Screw fixing freewheel to flywheel 13 ÷ 15

---

- Oil the free wheel "rollers".



---

## Refitting the intermediate gear

- Lubricate the gear housing on the engine crankcase.



- 
- Insert the intermediate gear with torque limiter

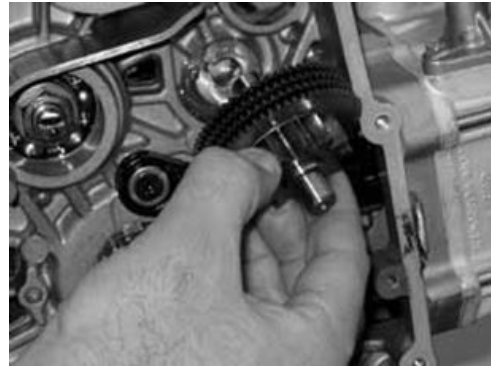

- 
- Lubricate the inside bushing and the starter ring gear hub surface.



- 
- Install the start-up rim on the flywheel turning it clockwise and inserting at the same time.



---

## Refitting the flywheel magneto

- 
- Insert the key on the crankshaft.
  - Install the flywheel checking the proper insertion of the key and engaging the torque limiter gear with the start-up rim.



- 
- Insert washer and nut on the crankshaft.



- 
- Tighten thoroughly the guide bushing of the flywheel lock tool and loosen by 1/4 turn.

**N.B.**

**FAILURE TO OBSERVE THIS RULE CAUSES THE LOCKING OF THE GUIDE ON THE FLYWHEEL.**

### **Specific tooling**

**020472Y Flywheel lock wrench**



- 
- Align the 2 holes of the flywheel with the case housing to allow the introduction of the special tool.

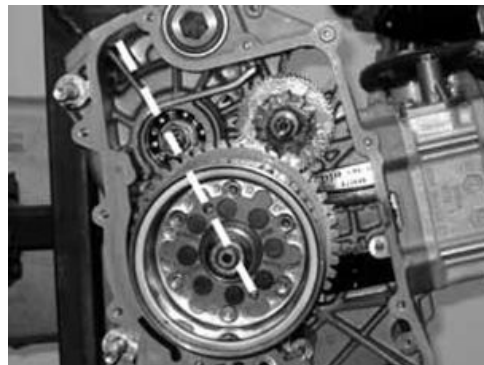

- 
- Insert the special tool checking that the pins are perfectly introduced into the seat.

### **Specific tooling**

**020472Y Flywheel lock wrench**





- Tighten the flywheel lock nut to the prescribed torque.

### Locking torques (N\*m)

Flywheel fixing nut 115 - 125

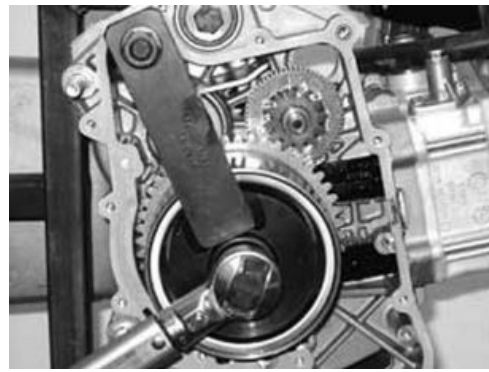

- Install the chain guide retain plate tightening the 3 screws to the prescribed torque.

### N.B.

**BEFORE TIGHTENING THE SCREWS, MOVE THE START-UP RIM IN CONTACT WITH THE CRANKCASE AND CHECK THAT IT IS FREE TO ROTATE IN ANTICLOCKWISE DIRECTION.**

### Locking torques (N\*m)

Chain guide sliding block retain plate fastening screws 3 ÷ 4



## Refitting the starter motor

- Check that the O-ring is in good working order and lubricate it.
- Insert the starter motor.
- Tighten the 2 fastening screws to the prescribed torque.

### Locking torques (N\*m)

Starter motor screws 11 ÷ 13



## Cylinder assy. and timing system

- Remove the external and internal transmission cover.



- Remove the flywheel cover, the flywheel and the torque limiter.



---

### Removing the intake manifold

- Remove the 3 mounting screws.
- Remove the intake manifold unit.



---

### Removing the rocker-arms cover

- Loosen the 6 special screws with stop and the relevant rubber gaskets.
- Remove the tappet cover with relevant gasket.

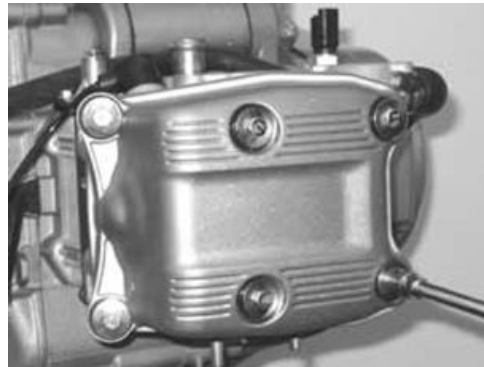

---

## Removing the timing system drive

---

- Turn the engine to close the intake valves, i.e., moving the reference on the tone wheel to the top, as shown in the figure.



- Remove the central screw and the valve lifting device mass stop bell using the special tool.

### Specific tooling

**020565Y Flywheel lock calliper spanner**

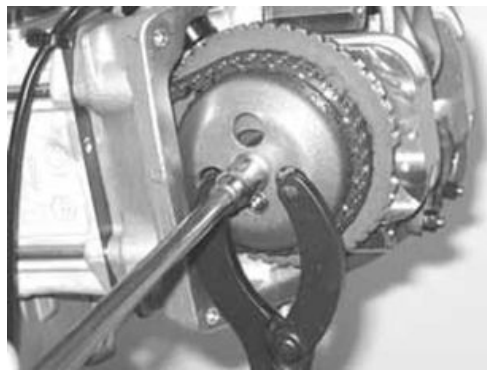

- Remove the return spring and the valve lifting mass with relevant travel end washer.

### N.B.

**BE CAREFUL NOT TO ALLOW THE WASHER AND SPRING TO FALL INTO THE ENGINE THROUGH THE CHAIN COMPARTMENT.**

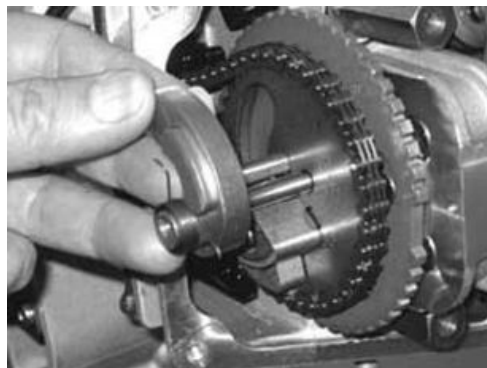

- Align the references located on the tone wheel and on the head.



- 
- Loosen the central screw on the tensioner first.
  - Unscrew the 2 fastening screws and remove the tensioner with relevant gasket.



- 
- Remove the inside hexagon screw and the counterweight as shown in the figure.



- 
- Remove the timing belt rim from the camshaft.
  - Remove the timing belt rim.



- 
- Remove the tone wheel.



- Remove the engine revolution timing sensor and relevant O-ring by loosening the fastening screw and removing the mounting band from the special hole obtained on the head gasket.

**N.B.**

**TO CHECK THIS COMPONENT, SEE THE INJECTION CHAPTER.**



## Removing the cam shaft

- Unscrew the 3 fastening screws and remove camshaft retaining bracket.

**N.B.**

**REMOVING THE FASTENING SCREWS MAY BE DIFFICULT. BE CAREFUL NOT TO DAMAGE THE INSIDE HEXAGON. IF NECESSARY, SEPARATE THE THREADS IN ADVANCE.**



- Remove the cam shaft.



- Remove pins and rocking levers by the transmission side holes.

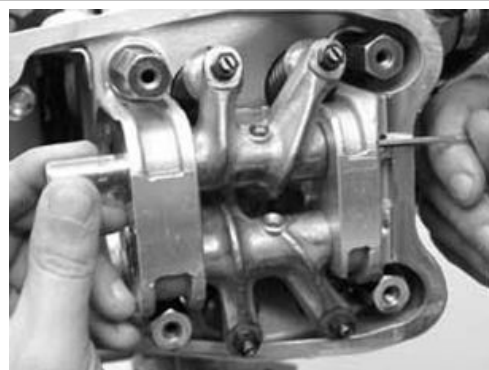

---

## Removing the cylinder head

---

- Remove the spark plug.
- Remove the cooling system outlet sleeve with thermostat.



- Remove the coolant temperature sensor.

**N.B.**

THE SENSOR CONTROLS BOTH INJECTION AND THE ANALOGUE INSTRUMENT ON THE PANEL. TO CHECK THIS COMPONENT, SEE THE INJECTION CHAPTER.



- Remove the 2 fastening nuts on the head, on the exhaust and on the intake side.

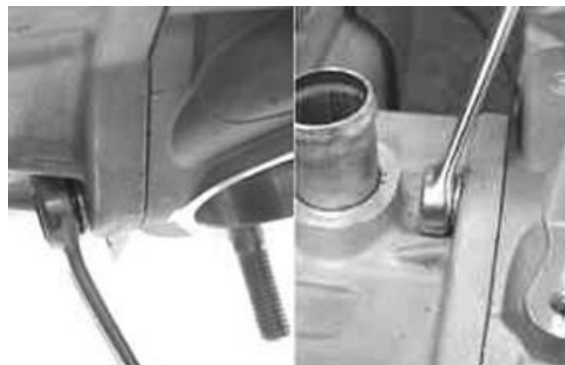

- Remove the two M6 screws into the distribution channel and the M6 screw on the spark plug side with the thermostat support.

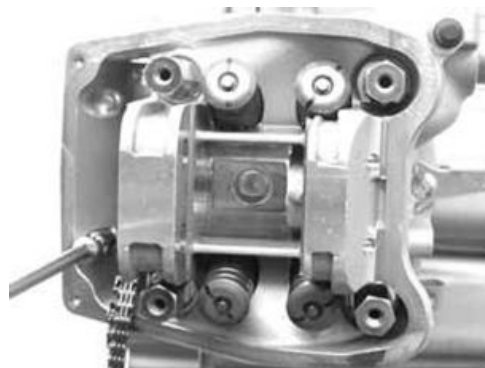
**N.B.**

THE HEAD MAY BE REMOVED WITH THE CAMSHAFT, ROCKING LEVER PINS AND FITTING BRACKET IF NECESSARY.

- Loosen the 4 head-cylinder fastening nuts in 2 or 3 times and in a crossed sequence.
- Remove the head, the 2 centring dowels, the gasket and the lower chain guide sliding block.

**N.B.**

**DO NOT REMOVE THE DOWELS IF THEY ARE FORCED INTO THEIR SEAT.**

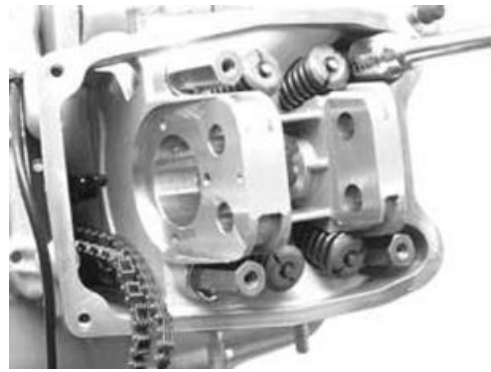

**CAUTION**

**WHEN YOU HAVE TO REMOVE THE HEAD, PREPARE A SUITABLE CONTAINER SINCE THE THERMAL GROUP CONTAINS COOLANT.**

## Removing the valves

- Using the appropriate tool fitted with an adaptor, remove the cotters, caps, springs and valves.

**Specific tooling**

**020382Y Valve cotters equipped with part 012 removal tool**

**020382Y012 bush (valve removing tool)**



**CAUTION**

**ARRANGE THE VALVES SO AS TO RECOGNISE THE ORIGINAL POSITION ON THE HEAD (FLY-WHEEL SIDE AND TRANSMISSION SIDE).**

- Remove the oil guards using the special tool.

**Specific tooling**

**020431Y Valve oil seal extractor**



- Remove the spring supports.

**N.B.**

**BLOW THE SEATS WITH COMPRESSED AIR TO FACILITATE THE SPRING SUPPORT REMOVAL.**



## Removing the cylinder - piston assy.

- Remove the timing chain.
- Loosen the fastening screw and remove the spacer and the tightening sliding block.

**N.B.**

**IT IS ADVISABLE TO MARK THE CHAIN IN ORDER TO ENSURE THAT THE INITIAL DIRECTION OF ROTATION IS MAINTAINED.**

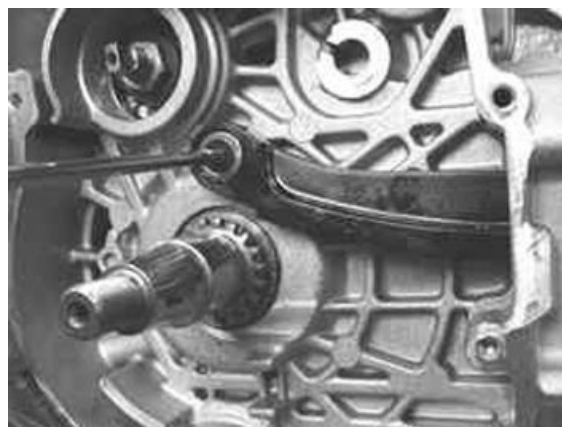

- Extract the cylinder with the relevant gasket and the centring dowel.

**N.B.**

**THE SECOND CENTRING IS ENSURED BY A PIN SET INTO THE CYLINDER.**

**CAUTION**

**TO PREVENT DAMAGES TO THE PISTON, SUPPORT IT WHILE REMOVING THE CYLINDER.**

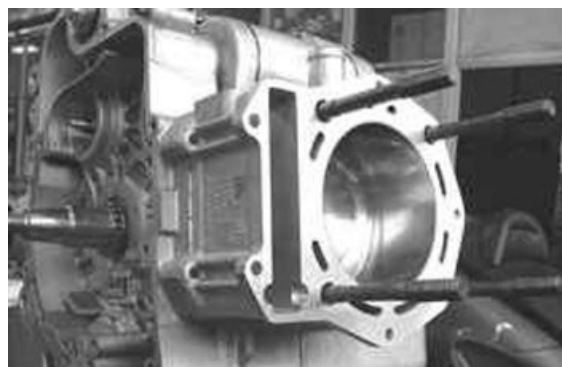

- Remove the 2 piston pin locking rings by the specific housings.
- Extract the pin and remove the piston.

**N.B.**

**USE PAPER OR A CLOTH TO CLOSE THE CYLINDER HOUSING MOUTH ON THE CRANKCASE TO PREVENT SLIPPAGE OF ONE OF THE PIN LOCKING RINGS INTO THE CASE.**





- Remove the piston sealing rings and the oil scraper.

**CAUTION**

**NOTE THE ASSEMBLY POSITIONS OF THE LININGS TO PREVENT INVERTING THE POSITION IN CASE OF REUSE.**

**N.B.**

**BE CAREFUL NOT TO DAMAGE THE SEALING RINGS DURING REMOVAL.**



### Inspecting the small end

- Using a bore gauge, measure the connecting rod small end diameter.

**N.B.**

**IF THE CONNECTING ROD SMALL END DIAMETER EXCEEDS THE STANDARD DIAMETER, EXHIBITS WEAR OR OVERHEATING, PROCEED TO REPLACE THE CRANKSHAFT AS DESCRIBED IN THE CRANKCASE AND CRANKSHAFT CHAPTER.**

**Characteristic**

**Standard diameter:**

22 + 0.025 +0.015 mm



### Inspecting the wrist pin

- Check the pin outside diameter using a micrometer.

**Characteristic**

**Standard diameter:**

22 0 -0.004 mm

- Calculate the coupling clearance between pin and connecting rod end.

**Characteristic**

**Standard clearance:**

0.015 ÷ 0.029 mm



- Measure the diameter of the bearings on the piston.

**Characteristic**

**Standard diameter:**

22 + 0.006 + 0.001 mm

- Calculate the piston pin coupling clearance.

**N.B.**

THE PIN HOUSINGS HAVE 2 LUBRICATION CHANNELS. FOR THIS REASON, MEASUREMENT MUST BE MADE ACCORDING TO THE PISTON AXIS.

**Characteristic**

**Standard clearance:**

0.001 ÷ 0.010 mm



**Inspecting the piston**

- Measure the outside diameter of the piston, perpendicular to the gudgeon pin axis.
- Take the measurement in the position shown in the figure.

**Characteristic**

**A =**

43.2 mm

**Piston diameter:**

92 mm



- Using a bore meter, measure the inner cylinder diameter at three different points according to the directions shown in the figure.

**Characteristic**

**Standard diameter:**

92 + 0.018 +0.010 mm



- Check that coating is free from flakes.
- Check that the head matching surface exhibits no deformations or wear.

**Characteristic**

**Maximum allowable run-out:**

0.05 mm

- Pistons and cylinders are classified into categories based on their diameter. The coupling is carried out in pairs (A-A, B-B, C-C, D-D).

- Carefully clean the seal housings.
- Measure the coupling clearance between the seal rings and the grooves using suitable sensors, as shown in the diagram.
- If the clearance is greater than that indicated in the table, replace the piston.

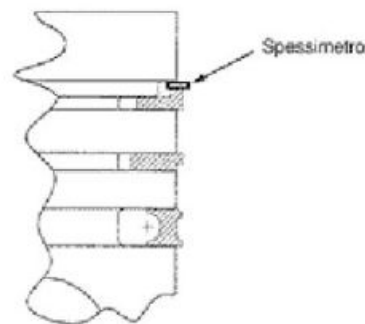

**N.B.**

**MEASURE THE CLEARANCE BY INSERTING THE BLADE OF THE FEELER THICKNESS GAUGE FROM THE SECOND SEAL SIDE.**



**Fitting clearance (Cylindrin/Pison)**

**Standard coupling clearance A** 0.9 - 0.005 - 0.030mm **B** 1.5 - 0.005 - 0.03mm **Maximum permissible clearance after use C** 0.9 + 0.03 + 0.01mm **D** 2 + 0.05 + 0.02mm **Standard coupling clearance** </> 1.2 - 0.005 mm </> </> **Maximum permissible clearance after use** </> 1.25 + 0.03 mm </> </> **Standard coupling clearance** </> 2.5 - 0.005 mm </> </> **Maximum permissible clearance after use** </> 2.5 + 0.03 mm </> </>

**Inspecting the piston rings**

- Alternately insert the three sealing rings into the cylinder, in the area where it retains its original diameter. Using the piston, insert the rings perpendicularly to the cylinder axis.
- Measure the opening (see figure) of the sealing rings using a feeler gauge.
- If higher values than those prescribed are measured, replace the linings.



**N.B.**

**BEFORE REPLACING ONLY THE PISTON RINGS, ENSURE THAT THE CLEARANCE BETWEEN THE PISTON RINGS AND THE PISTON RING GROOVES, AND BETWEEN THE PISTON AND THE CYLINDER, IS AS SPECIFIED. IN ANY CASE, NEW PISTON RINGS USED IN COMBINATION WITH A USED CYLINDER MAY HAVE DIFFERENT BEDDING CONDITIONS THAN THE STANDARD.**

**Fitting clearance (Cylindrin/Pison)**

**Compression ring** 0.15 ÷ 0.35 mm Max. value. 0.5 mm </> **Oil scraper ring** 0.25 ÷ 0.50 mm Max. value. 0.65 mm </> **Oil scraper ring** 0.25 ÷ 0.50 mm Max. value. 0.65 mm </>

## Removing the piston

- Install piston and wrist pin onto the connecting rod, aligning the piston arrow the arrow facing towards the exhaust.



- Insert the locking ring into the special tool, with the opening in the position indicated on the tool.

S = left

D= right



- Place the wrist pin stop ring into position using a punch



- Install the pin lock using the key shown in the figure.

### Specific tooling

**020470Y Pin retainers installation tool**



**N.B.**

**THE TOOL FOR INSTALLING THE STOP RINGS MUST BE USED MANUALLY.**

**CAUTION**

**USING A HAMMER MIGHT DAMAGE THE STOPS' HOUSING.**

## Choosing the gasket

- Provisionally fit the piston into the cylinder, without any base gasket.
- Install a comparator on the special tool using the short union, as shown in the figure.

### Specific tooling

#### 020475Y Piston position checking tool

- Using an abutment plane, reset the comparator with a preload of a few millimetres.
- Finally fix the comparator.
- Check the perfect sliding of the feeler pin.
- Install the tool on the cylinder without changing the comparator position.
- Lock the tool using the original head fixing nuts.
- Rotate the crankshaft up to the TDC (the inversion point of the dial gauge rotation)
- Measure the deviation from the reset value.



- Identify the thickness of the cylinder base gasket to be used for reassembly by the table below. Correctly identify the cylinder base gasket thickness to keep the correct compression ratio.
- Remove the special tool and the cylinder.

#### **N.B.**

**IF DEVIATIONS (OR RECESSES OR PROJECTIONS) CLOSE TO THE CHANGE OF CATEGORY ARE MEASURED, REPEAT THE MEASUREMENT AT THE OPPOSED SIDE. TO DO SO, REPEAT THE TOOL INSTALLATION BY INVERTING ITS POSITION.**

#### **Characteristic**

##### **Recess / Projection measured 1**

- 0.185 - - 0.10

##### **Gasket thickness 1**

0.4 ± 0.05

##### **Recess / Projection measured 2**

- 0.10 - + 0.10

##### **Gasket thickness 2**

0.6 ± 0.05

##### **Recess / Projection measured 3**

+ 0.10 ÷ + 0.185

### Gasket thickness 3

0.8 ± 0.05

## Refitting the piston rings

- Place the scraper ring spring on the piston.
- Install the scraper ring keeping the opening opposed to the spring junction and with the writing "top" facing the piston top. The chamfered side of the oil scraper ring should always be facing the piston crown.
- Fit the second lining with the identification letter or the writing "top" facing the piston crown. In any case, the step must be facing opposite the piston top.
- Install the first compression lining in the direction imposed by the housing.
- It is advisable to use a fitter to facilitate the installation of the linings.



### N.B.

**THE TWO PISTON RINGS ARE MADE WITH A TAPERED CYLINDRICAL CONTACT CROSS-SECTION. THIS IS TO ACHIEVE A BETTER BEDDING.**

- Misalign the lining openings at 120° as shown in the figure.
- Lubricate the components with engine oil.
- The engine uses the first compression lining with an L section.

## Refitting the cylinder

- Insert the cylinder base gasket with the thickness determined above.
- Using the fork and the ring clamp, fit the cylinder as shown in the figure.

### N.B.

**BEFORE FITTING THE CYLINDER, CAREFULLY BLOW THE LUBRICATION DUCT AND LUBRICATE THE CYLINDER LINER. CHECK THE PRESENCE OF THE TWO REFERENCE DOWELS.**

### Specific tooling

**020468Y Piston fitting band**

**020512Y Piston fitting fork**



## Inspecting the cylinder head

- Using a trued bar and a feeler thickness gauge check that the cylinder head surface is not worn or distorted.

### Characteristic

#### Maximum allowable run-out:

0.1 mm

- In case of irregularities, replace the head.
- Check the sealing surfaces for the intake and exhaust manifold.
- Check that the bearings of the camshaft and the rocker pins exhibit no wear.
- Check that the head cover surface is not worn.
- Check that the coolant sealing pad exhibits no oxidation.



### STANDARD DIAMETER

Specification	Desc./Quantity
A	13 + 0.018 0
B	20 + 0.021 0
C	42 + 0.025 0

- If wear is discovered, replace the head and check also the corresponding component.

## Inspecting the timing system components

- Check that the guide shoe and the tensioner shoe are not worn out.
- Check that the crankshaft pinion and the camshaft timing gear and crankshaft pinion exhibit no wear.

In case of wear of the sliding blocks, replace them.  
 In case of wear of the chain or rim, replace the entire unit.



### **N.B.**

**IF THE CHAIN HAS DAMAGED THE PINION, REPLACE THE CRANKSHAFT AS DESCRIBED IN CHAPTER CRANKCASE AND CRANKSHAFT.**

- Remove the centre screw with the washer and the tensioner spring. Check that the one-way mechanism is not worn.
- Check the condition of the tensioner spring.
- If examples of wear are found, replace the whole assembly.



## Inspecting the valve sealings

- Insert the valves into the cylinder head.
- Alternatively check the intake and exhaust valves.
- The test is carried out by filling the manifold with petrol and checking that the head does not ooze through the valves when these are just pressed with the fingers.



- Visually inspect the valve sealing surface.

### CAUTION

**DO NOT REVERSE THE FITTING POSITIONS OF THE VALVES (RIGHT - LEFT).**

- If the sealing surface of the valve is found to be interrupted at one or more points or is not flat, replace the valve.





### Inspecting the valve housings

- Clean the valve seats of any carbon residues.
- Using the Prussian blue, check the width of the impression on the valve seat "V".
- Measure the inside diameter of each valve guide.
- Measure according to the rocking lever thrust direction at three different heights.

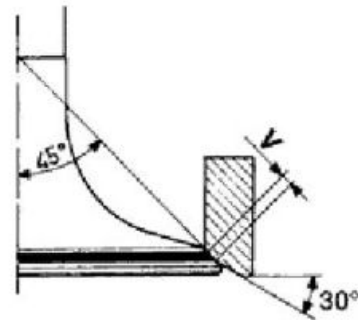

**Characteristic**

**Standard value:**

1 - 1.3 mm

**Admissible limit:**

1.6 mm

- If the impression width on the valve seat is larger than the prescribed limits, true the seats with a 45° mill and then grind.
- In case of excessive wear or damages, replace the head.

### Inspecting the valves

- Measure the diameter of the valve stems in the three positions indicated in the diagram.

**STANDARD DIAMETER**

Specification	Desc./Quantity
Inlet:	4.987 - 4.972 mm
Outlet:	4.975 - 4.960 mm

**MINIMUM ADMISSIBLE DIAMETER**

Specification	Desc./Quantity
Inlet:	4.96 mm
Outlet:	4.945 mm

- Calculate the clearance between valve and valve guide.

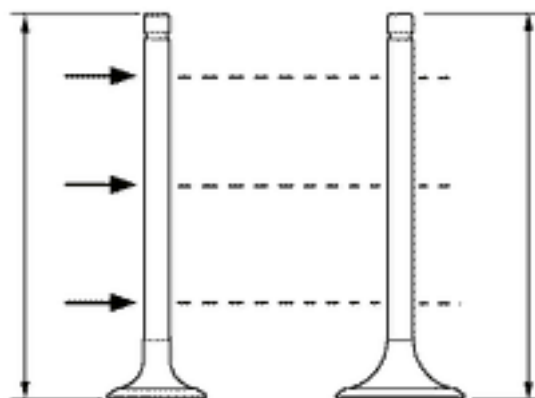

- Check the deviation of the valve stem by resting it on a "V" shaped abutment and measuring the extent of the deformation with a comparator.

**Characteristic**

**Limit values admitted:**

0.1 mm

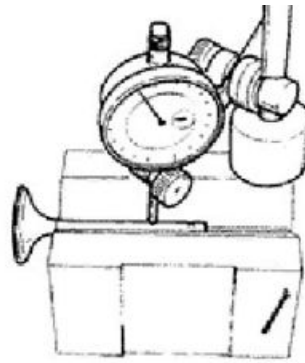

- Check the concentricity of the valve head by arranging a comparator at right angle relative to the valve head and rotate it on a "V" shaped abutment.

**Characteristic**

**Admissible limit:**

0.03 mm

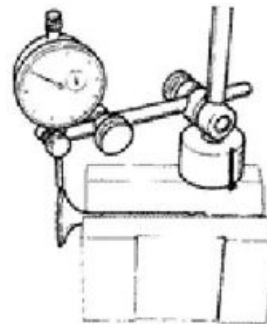

**Inspecting the valve stem guide clearance**

- After measuring the valve guide diameter and the valve stem diameter, check clearance between guide and stem.

**INLET**

Specification	Desc./Quantity
Standard clearance:	0.013 - 0.04 mm
Admissible limit:	0.08 mm

**OUTLET**

Specification	Desc./Quantity
Standard clearance:	0.025 ÷ 0.052 mm
Admissible limit:	0.09 mm



### STANDARD VALVE LENGTH

Specification	Desc./Quantity
Inlet:	95.0 ± 0.3 mm
Outlet:	94.2 ± 0.3 mm

- Check that there are no signs of wear on the surface of contact with the articulated register terminal.

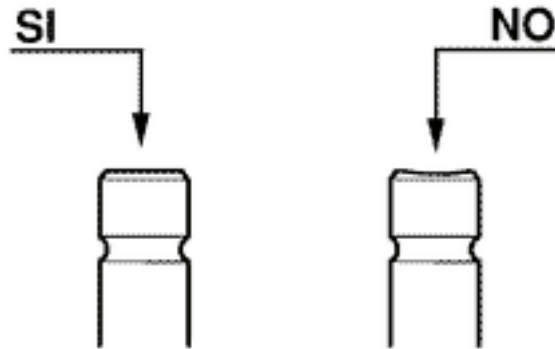

- If no anomalies are found during the above checks, you can use the same valves. To obtain better sealing performance, grind the valve seats. Grind the valves gently with a fine-grained lapping compound. During the grinding, keep the cylinder head with the valve axes in a horizontal position. This will prevent the lapping compound residues from penetrating between the valve stem and the guide (see figure).



#### CAUTION

**TO AVOID SCORING THE FAYING SURFACE, DO NOT KEEP ROTATING THE VALVE WHEN NO LAPPING COMPOUND IS LEFT. CAREFULLY WASH THE CYLINDER HEAD AND THE VALVES WITH A SUITABLE PRODUCT FOR THE TYPE OF LAPPING COMPOUND BEING USED.**

#### CAUTION

**DO NOT REVERSE THE FITTING POSITIONS OF THE VALVES (RIGHT - LEFT).**

### Inspecting the springs and half-cones

- Check that the upper spring caps and the cotter halves show no signs of abnormal wear.



- Measure the unloaded spring length.

**Characteristic**

**Standard length:**

44.4 mm

**Admissible limit after use:**

42.4 mm



**Refitting the valves**

- Place the valve spring support washers on the head.
- Alternately insert the 4 oil guards using the special tool.
- Lubricate the oil guards and the valve guides.



**Specific tooling**

**020306Y Punch for assembling valve seal rings**

- Fit the valves, the springs and the caps. Using the appropriate tool with adapter, compress the springs and insert the cotters in their seats.



**Specific tooling**

**020382Y Valve cotters equipped with part 012 removal tool**

**020382Y012 bush (valve removing tool)**

**N.B.**

**DO NOT CHANGE THE VALVE FITTING POSITION. FIT THE VALVE SPRINGS WITH THE REFERENCE COLOUR ON COTTER SIDE (TURNS WITH GREATER PITCH).**

**Inspecting the cam shaft**

- Check that the camshaft bearings exhibit no scores or abnormal wear.
- Using a micrometer, measure the camshaft bearings.

**STANDARD DIAMETER**

Specification	Desc./Quantity
Bearing A Ø:	42 - 0.060 -0.085 mm
Bearing B diameter:	20 - 0.020 -0.041 mm

**MINIMUM ADMISSIBLE DIAMETER**

Specification	Desc./Quantity
Bearing A Ø:	41.910 mm
Bearing B diameter:	19.940 mm



-Using a gauge, measure the cam height.

**STANDARD HEIGHT**

Specification	Desc./Quantity
Intake	33.988 mm
Exhaust:	33.417 mm

**ADMISSIBLE LIMITS**

Specification	Desc./Quantity
Intake	33.740 mm
Exhaust:	33.170 mm
Standard axial clearance:	0 - 0.22 mm
Maximum admissible axial clearance:	0.3 mm

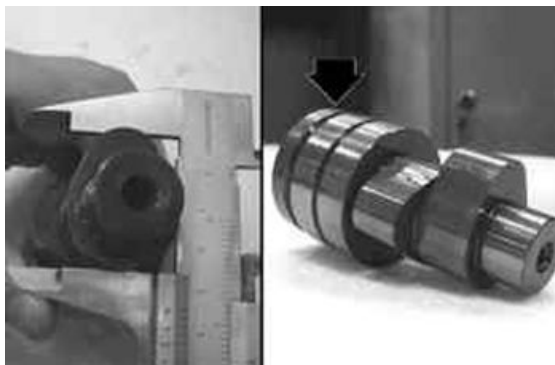

- If any of the above dimensions are outside the specified limits, or there are signs of excessive wear, replace the defective components with new ones.

- Check that the retaining plate seat shown in the figure exhibits no wear.

- Check that the automatic valve lifting device cam, the travel end roller and the rubber abutment on the containment bell are free from wear.



- Check that the valve lifting spring has not yielded.
- Replace any defective or worn components.
- Check that the rocking lever pins exhibit no scores or wear.

**Characteristic****Standard diameter:**

13 - 0.010 -0.018 mm

- Measure the inside diameter of each rocking lever.

**Characteristic****Standard diameter:**

13 + 0.026 +0.015 mm

- Check that the cam contact sliding block and the articulated register plate is free from wear.
- In case of wear, replace the component.



---

**Refitting the head and timing system components**

- Insert the chain guide sliding block.
- Insert the two centring dowels between head and cylinder.
- Install the head gasket.



**N.B.**

**THE FIGURE SHOWS THE INSERTION POSITION OF THE TWO CENTRING DOWELS BETWEEN HEAD AND CYLINDER. THE DIRECTION OF INSTALLATION FOR THE GASKET IS FORCED BY THE DOWELS.**

- The head gasket is made of steel and has a standard thickness.

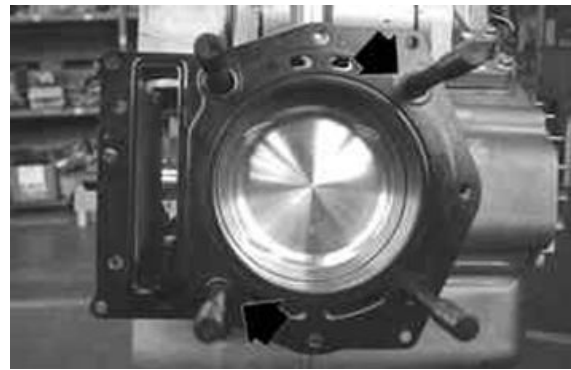

- Check that the head lubrication channel is perfectly clean. Clean with compressed air jets, if required.
- Insert the head.
- Lubricate the stud bolts and the 4 fixing stud bolts.



- Tighten the 4 fastening columns crosswise to the prescribed torque as shown in the figure.
- Tighten the 4 screws by 90° in the sequence shown in the figure.
- Further tighten by 90° in the sequence shown in the figure.

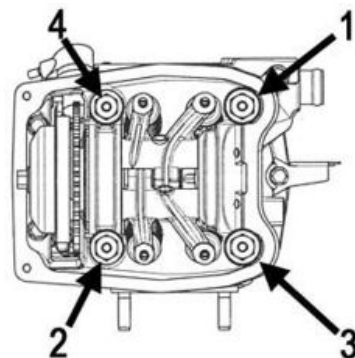

**Locking torques (N\*m)**

**Head fixing stud bolts \*\*\***

- Tighten the fastening nuts on the exhaust and on the intake side to the prescribed torque.

**Locking torques (N\*m)**

**Exhaust / intake head fixing nuts 10 - 12**

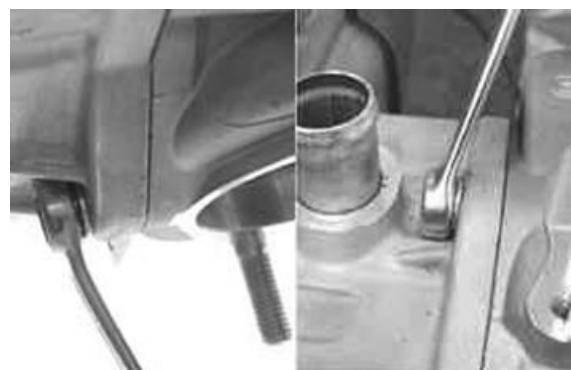

- Tighten the 3 side screws to the prescribed torque.

### Locking torques (N\*m)

Head fixing screws 10 - 12

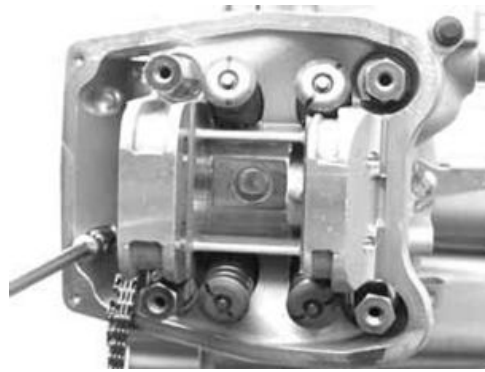

- Install the coolant temperature sensor with the washer and tighten to the prescribed torque.

#### CAUTION

FAILURE TO OBSERVE THE TIGHTENING TORQUE CAN DAMAGE THE SENSOR.

### Locking torques (N\*m)

coolant temperature sensor: 10 - 12



- Install the spark plug and tighten to the prescribed torque.

### Locking torques (N\*m)

Spark plug 12 ÷ 14

- Insert the timing control belt on the crankshaft according to the initial direction of rotation.
- Install the tensioner shoe with its spacer, tightening the bolt to the prescribed torque, using the recommended product.

### Recommended products

Loctite 243 Medium strength threadlock

Loctite 243 medium-strength threadlock



### Locking torques (N\*m)

Tensioner sliding block fixing screw 10 - 14

- Insert pins and rocking levers on the flywheel side.
- Lubricate the two rocking levers through the holes at the top.





- Clean the camshaft by blowing with little compressed air jets, especially the retaining plate housing.
- Lubricate the 2 shafts.
- Insert the camshaft into the head with the cams opposite the rocking levers.



- Remove any LOCTITE residues from the screws fixing the camshaft retaining bracket using a brush.
- Apply the recommended product to the fixing screws and tighten the screws after wiping off any threadlock deposits.

### Recommended products

#### Loctite 243 Medium strength threadlock

Loctite 243 medium-strength threadlock

- Insert the camshaft retain bracket with visible countersinks and tighten the 3 fastening screws to the prescribed torque, being careful not to damage the inside hexagon.

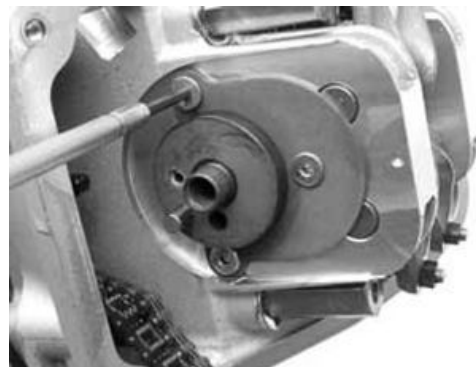

### Locking torques (N\*m)

Camshaft retaining bracket screws: 4 ÷ 6

- Check that the tothing and the housing of the tone wheel timing peg are free from deformations or dents.



- Insert the wheel speed sensor on the camshaft keeping the stroke reference visible.

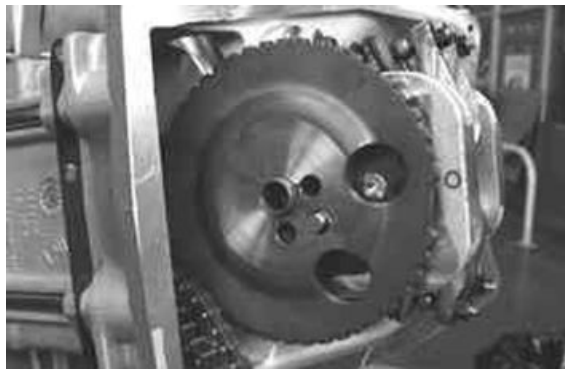

- Install the engine revolution timing sensor using a new O-Ring, orientating it as shown in the figure. Tighten the 2 fastening screws to the prescribed torque.

**N.B.**

**TO CHECK THIS COMPONENT, SEE CHAPTER "INJECTION".**

### **Locking torques (N\*m)**

**Rpm timing sensor fixing screw 3 - 4**



- Install the intermediate gear with torque limiter, the flywheel and its cover, as described in Chapter "Flywheel and start-up system", and in Chapter "Flywheel cover".

**N.B.**

**FOR MORE CONVENIENCE, INSTALL THE FLYWHEEL COVER WITHOUT THE COOLING SYSTEM SLEEVES.**



- Using the TORX wrench, remove the timing check cap.



- Align the wheel speed sensor references with the head as shown in the figure.

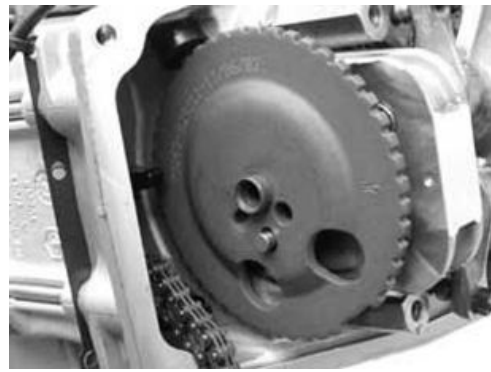

- Keeping the belt slightly pulled, turn the crankshaft using the driving pulley to make the reference on the magnet support collimate with that on the flywheel cover.



- Insert the belt on the camshaft control timing rim.
- Insert the timing rim on the camshaft checking that the references are aligned.

**N.B.**

**DURING THE STROKE CHECK, KEEP THE BELT TENSIONED BY PRESSING ON THE TIGHTENER COMPARTMENT SIDE.**



- Install the counterweight mass.
- Centre using the bell fastening screw.
- Lock the mass fixing screws to the prescribed torque, using the recommended product.

**Recommended products**

**Loctite 243 Medium strength threadlock**

Loctite 243 medium-strength threadlock

**Locking torques (N\*m)**

**Counterweight screw 7 ÷ 8.5**



- Remove the central screw.
- Install the valve lifting mass being careful to the proper positioning of the travel end ring.
- Lubricate the mass and de-compressor control pin.



- Install the return spring and load it by about 3/4 turn.



- Turn the engine to move the references to the top as shown in the figure (intake end).



- Insert the valve lifting device mass stop bell.
- Tighten the retaining screw to the prescribed torque, using the recommended product.

**N.B.**

**THE BELL TIMING IS ENSURED BY THE COUNTERWEIGHT MASS FASTENING SCREW HEAD.**

### **Recommended products**

**Loctite 243 Medium strength threadlock**

Loctite 243 medium-strength threadlock

- Check that the decompression mass is free and that it is pulled by the spring.



**Locking torques (N\*m)**

**Valve lifter mass stop bell fixing screws 30 - 35**

- Place the engine with the valve clearance adjustment timing references aligned with the head.
- Check the clearance between valve and rocking lever using a thickness gauge.

**PRESCRIBED CLEARANCE**

Specification	Desc./Quantity
Inlet	0.15 mm (engine cold)
drainage	0.15 mm (engine cold)

- In case different values are found, adjust by loosening the lock nut and use a screwdriver for the set screw as shown in the figure.



**Refitting the timing chain**

This section described the operations to be carried out on the manifold components.

Ignition advance is determined electronically on the basis of parameters known by the control unit. For this reason it is not possible to interpret the reference values based on the engine rpm.

The ignition advance value is detectable at any time using the diagnostic tester.

It is possible to check whether the ignition advance determined by the injection system matches the value actually activated on the engine, by means of the stroboscopic light.

**Specific tooling**

**020460Y Scooter diagnosis and tester**

**020330Y Stroboscopic light to check timing**

Proceed as follows:

- Remove the outside transmission cover as described in the automatic transmission chapter.

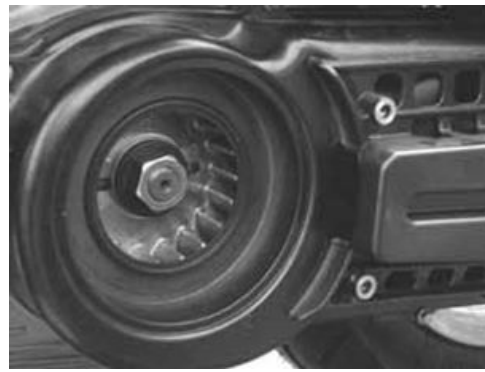

- Remove the TDC reference inspection cap between flywheel and crankcase cover. See the flywheel cover chapter.



- By the driving pulley, turn the engine to find the alignment of the references to identify the TDC.



- Repeat for the reference between driving pulley and transmission housing.



- Replace the inspection cap on the flywheel side.
- Connect the diagnostic tester.
- Start the engine.
- Select the «parameter» function in this menu.
- Select the stroboscopic light command in the traditional four-stroke engine position (1 spark 2 revs).
- Check that the real values of rpm and ignition advance match those measured using the diagnostic tester.



### **Specific tooling**

#### **020460Y Scooter diagnosis and tester**

#### **If the values do not match, check:**

- distribution timing
- rpm-timing sensor
- injection control unit

---

## **Inspecting the radial air gap**

- Align a tooth of the tone wheel with the revolution timing sensor.
- Check the air gap using a probe.

### **Characteristic**

#### **Standard air gap:**

from 0.20 to 0.70 mm

- Repeat the check at 3 - 4 points.



- 
- Place the tightener cursor in the rest position, keeping the retain tab pressed.



- 
- Install a new tightener on the cylinder using a new gasket.
  - Tighten the two fastening screws to the prescribed torque.

**Locking torques (N\*m)****Tightener fastening screws: 11 ÷ 13**

- 
- Insert the spring with the central screw and the washer.
  - Tighten the central screw to the prescribed torque.

**Locking torques (N\*m)****Tightener screw: 5 - 6**

---

**Refitting the rocker-arms cover**

- 
- Check that the gasket is in good working order.

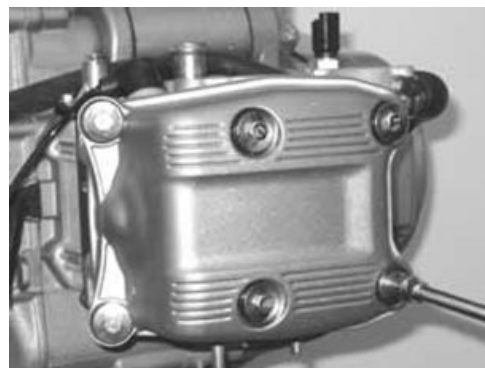



- Tighten the two screws indicated in the figure with «1» and «2» to limit the reciprocal sliding of the cover surface with the head surface.
- Tighten the remaining 4 screws in a crossed sequence (3, 4, 5, 6).

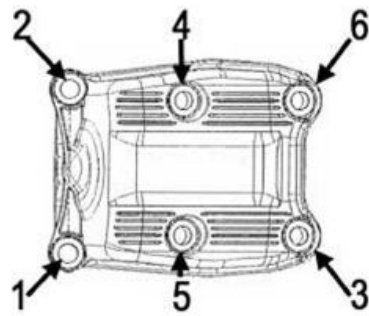

**N.B.**

**CHECK THE PROPER POSITION OF THE GASKET.**

### Locking torques (N\*m)

#### Tappet cover fixing screws 7 - 9

- Install the transmission cover and the relevant net filter and the outside transmission cover as described in the "Automatic transmission" chapter.



- Install the cooling system sleeves using new bands, as described in the "Flywheel cover" chapter.

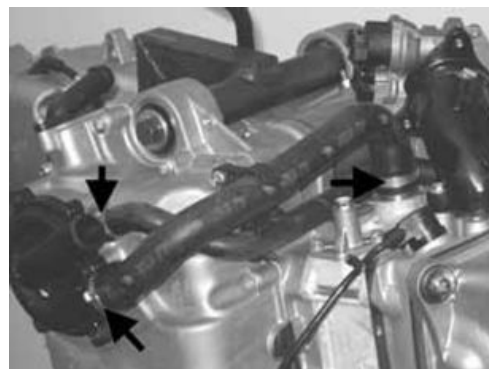

## Refitting the intake manifold

- Install the intake manifold on the engine.
- Insert the 3 fastening screws, one of which with a support band for the cooling system sleeve, and tighten to the prescribed torque.

### Locking torques (N\*m)

#### Inlet manifold screws 11 ÷ 13



---

## Crankcase - crankshaft

---

- Remove the outside and inside transmission cover and the complete driving pulley as described in "Automatic transmission".



- Remove the flywheel cover with the cooling system sleeves, as described in the "Flywheel cover" chapter.



- Remove the flywheel with the starting system following the instruction given in "Flywheel and Starting system".



- Remove the thermal group (cylinder, head, piston) as described in the «Thermal group and timing system chapter».

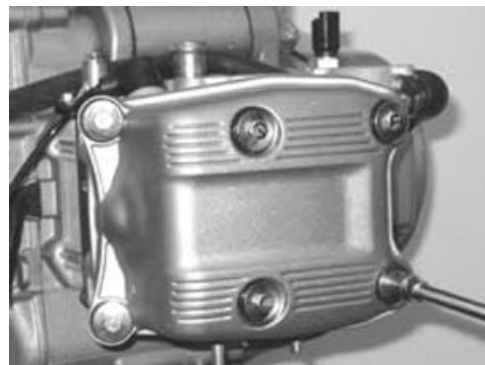

- 
- Before opening the crankcase, check the crankshaft axial clearance.

For this purpose, use a plate (e.g. the special tool) and a support with special tool comparator.



### Specific tooling

**020262Y Crankcase splitting strip**

**020335Y Magnetic support for dial gauge**

### Characteristic

**Standard clearance:**

0.10 - 0.50 mm

**Admissible increase limit after use:**

0.60 mm

- Upper clearances are an indication of wear on the surfaces of the crankshaft casing support.
- To carry out an accurate measurement, measure the clearance in both directions between crankcase and crankshaft.

---

## Splitting the crankcase halves

- Remove the engine support retain screw on the flywheel side half-crankcase.



- Remove the 14 crankcase coupling screws.

**N.B.**

**THE FASTENING SCREWS ARE OF 3 DIFFERENT LENGTHS. NOTE THEIR CORRECT POSITION.**

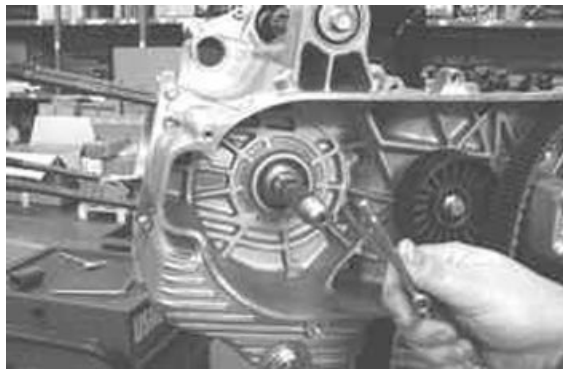

- Split the crankcases while keeping the crankshaft inserted on the flywheel side half-crankcase.
- Remove the coupling gasket.

**N.B.**

**THE BUSHING SUPPORT CAN BE LEFT IN THE FLY-WHEEL SIDE HALF-CRANKCASE.**



## Removing the crankshaft

- Before removing the crankshaft, check the timing with the countershaft. To carry out this check, turn the crankshaft to align the two holes obtained on the crankshaft with the hole on the countershaft control gear.

This is an optimal position also to remove the crankshaft.



- Remove the crankshaft with the shim adjustment washer on the flywheel side.

**CAUTION**

**WHILE OPENING THE CRANKCASE AND REMOVING THE CRANKSHAFT, CHECK THAT THE SHAFT THREADED ENDS DO NOT INTERFERE WITH THE MAIN BEARINGS. FAILURE TO OBSERVE THIS PRECAUTION CAN DAMAGE THE MAIN BEARING.**



---

**Removing the oil pump and countershaft control gear.**

- To remove the control gear, loosen the 4 fastening screws.

**Remove the gear only if actually required.**

**CAUTION**

THE SCREWS HAVE A COUNTERSUNK HEAD AND THEIR THREADING IS LOCKED BY LOCTITE. BE CAREFUL NOT TO DAMAGE THE CONTROL HEXAGON. TO OBTAIN BETTER RESULTS IT IS PREFERABLE TO USE AN INSIDE HEXAGON SOCKET WRENCH.



---

**Removing the countershaft**

- Place the special tool as shown in the figure.

**Specific tooling**

**020479Y Countershaft lock wrench**



- Remove the fastening nut with relevant washer.



- Remove the special tool and extract the countershaft with the control gear.



## Replacing the countershaft bearings

- Check that the bearings are free from irregular noise or clearance. If it does, replace it.

### Flywheel-side half-crankcase

- Remove the inside Seeger ring.



- Upturn the half-crankcase.
- Remove the bearing from the flywheel side half-crankcase using the special tool and a mallet.

### Specific tooling

**020376Y Adaptor handle**

**020358Y 37x40-mm adaptor**

**020439Y 17 mm guide**



- Remove the bearing from the transmission side half-crankcase using the special tool.

### Specific tooling

**001467Y008 Pliers to extract 17 mm  $\varnothing$  bearings**

**001467Y007 Driver for OD 54-mm bearings**



- Before installing a new bearing, heat the flywheel side half-crankcase using the special tool.
- Place the half-crankcase on a wooden base.

### Specific tooling

**020151Y Air heater**



- Insert a new bearing on the special tool after greasing the guide seat.
- Install the new bearing on the half-crankcase using the special tool.

**N.B.**

**IF A BEARING WITH PLASTIC CAGE IS USED, KEEP THE BALLS VISIBLE FROM THE CRANKCASE INTERNAL SIDE.**

**Specific tooling**

**020376Y Adaptor handle**

**020359Y 42x47-mm adaptor**

**020439Y 17 mm guide**



- Fit the Seeger ring.



- Before installing the new bearing on the transmission side crankcase, heat the seat using the special tool.

**Specific tooling**

**020151Y Air heater**



- Insert a new bearing on the special tool after greasing the guide seat.
- Install the new bearing on the engine crankcase using the special tool.

**N.B.**

**IF A BEARING WITH PLASTIC CAGE IS USED, KEEP THE BALLS VISIBLE FROM THE CRANKCASE INTERNAL SIDE.**

**Specific tooling**

**020376Y Adaptor handle**

**020359Y 42x47-mm adaptor**



## 020439Y 17 mm guide

## Inspecting the crankshaft components

- Check the axial clearance on the connecting rod.

### Characteristic

#### Standard clearance:

0.20 ÷ 0.40 mm



- Check the connecting rod diametrical clearance.

### Characteristic

#### Standard clearance:

0.046 ÷ 0.076 mm

- Check the surfaces that limit the axial free-play are not scored and measure the width of the crankshaft between these surfaces, as shown in the diagram.

#### N.B.

BE CAREFUL NOT TO LET THE MEASUREMENT BE AFFECTED BY THE UNIONS WITH THE CRANKSHAFT ENDS.

### Characteristic

#### Standard dimensions:

63.6 - 63.45 mm

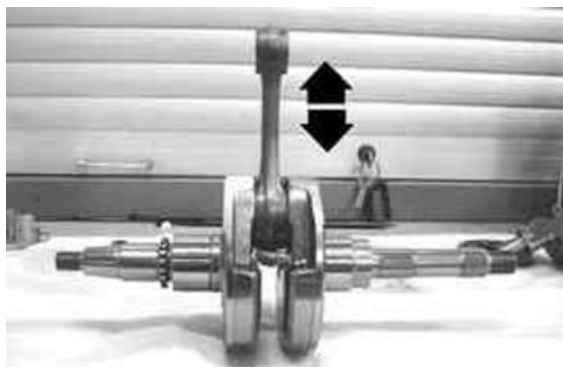

#### CAUTION

THE CRANKSHAFT CAN BE REUSED WHEN THE WIDTH FALLS WITHIN THE STANDARD VALUES AND THE SURFACES ARE FREE FROM SCRATCHES.

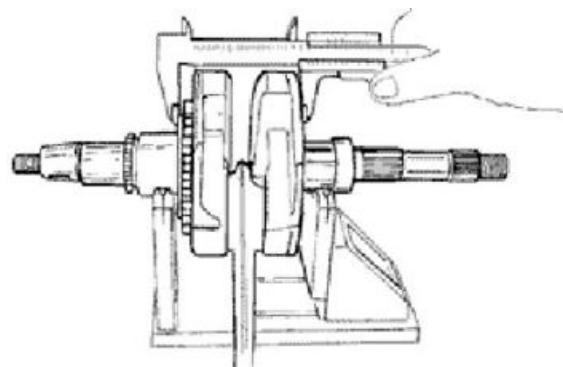

## Shimming

- Check the overall height of the crankshaft - shoulders - gear assembly.

### Characteristic

#### Standard thickness:

71.804 - 72.000 mm



- Check that shim adjustment is free from scratches.

**N.B.**

**IN CASE OF NEW UTILISATION, MAINTAIN THE FIRST FITTING POSITION.**

**Specific tooling**

**020074Y Support base for checking crankshaft alignment**

- If the crankshaft - crankcase axial clearance is higher than the standard value and the crankshaft exhibits no irregularity, the problem is caused by wear or by a wrong machining on the engine crankcase.

- Check the diameters of both the bearings of the crankshaft in accordance with the axes and surfaces shown in the figure. Half-shafts are classified into two categories, Cat. 1 and Cat. 2.

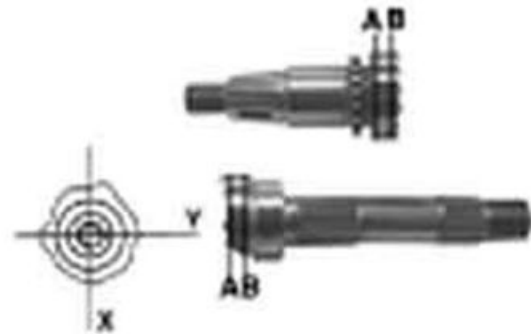

**STANDARD DIAMETER**

Specification	Desc./Quantity
Cat. 1	40.010 ÷ 40.016
Cat. 2	40.016 ÷ 40.022

**Inspecting the crankshaft alignment**

- Install the crankshaft on the support and measure the displacement at the 4 points shown in the figure.

**Specific tooling**

**020074Y Support base for checking crankshaft alignment**

**MAX ADMISSIBLE DISPLACEMENT:**

Specification	Desc./Quantity
A	= 0.15 mm
B	= 0.01 mm
C	= 0.01 mm
D	= 0.10 mm

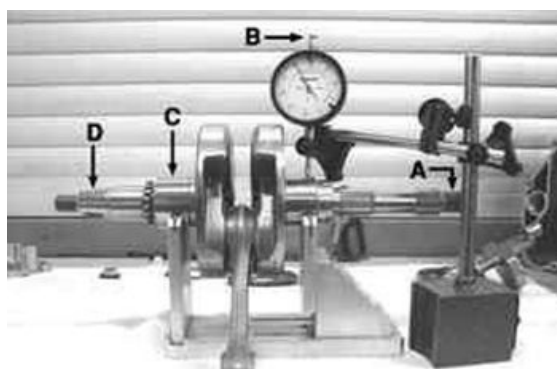

- Check that the driving shaft cone, the tab seat, the oil seal capacity, the toothed gear and the threaded tangs are in good working order.

- In case of failures, replace the crankshaft.

**N.B.**

**MAIN BEARINGS CANNOT BE MODIFIED.**

The connecting rod cannot be replaced. To check the connecting rod small end diameter, see chapter "Thermal group and timing system".

- When cleaning the crankshaft, be careful to prevent any impurity from entering into the shaft lubrication hole.

**N.B.**

IN CASE OF REPLACEMENT OF A CRANKSHAFT CONSISTING OF TWO HALF-SHAFTS OF DIFFERENT CATEGORY, REPLACE THE TWO HALF-CRANKCASES AS WELL, COUPLING THE TWO COMPONENTS (SHAFT AND CRANKCASE) WITH THE SAME CATEGORY.

- To check the gearing of the crankshaft, see section "Thermal group and timing system".

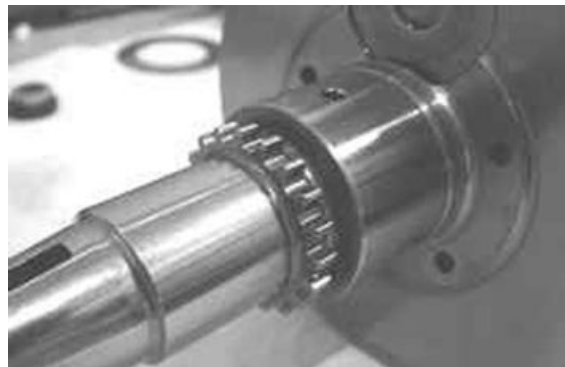

**See also**

[Cylinder assy. and timing system](#)

---

## Inspecting the crankcase halves

- Before proceeding to check the crankcase halves, thoroughly clean all surfaces and oil ducts.
- For the transmission-side half-crankcase, special attention should be given to the bushings, to the cooling jet on the transmission side (see figure) and to the lubrication duct.



**N.B.**

THE JET IS FED THROUGH THE MAIN BUSHINGS. PROPER OPERATION OF THIS COMPONENT IMPROVES THE PISTON TOP COOLING. CLOGGING HAS EFFECTS THAT ARE DIFFICULT TO DETECT (PISTON TEMPERATURE INCREASE). FAILURE OR LEAK CAN CONSIDERABLY DECREASE THE MAIN BUSHING AND CONNECTING ROD LUBRICATION PRESSURE.

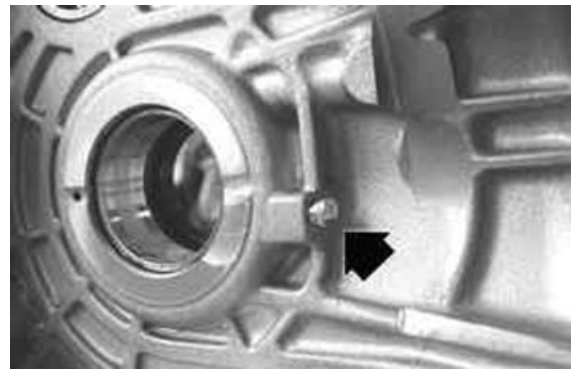

- For the flywheel side half-crankcase, special attention should be given to the lubrication channels for the main bearings and to the compartment and the channels for the oil pump, as well as to the duct for the by-pass located on the flywheel cover.

**N.B.**

AS ALREADY DESCRIBED IN THE "LUBRICATION" CHAPTER, IT IS ESPECIALLY IMPORTANT THAT THE BY-PASS HOUSING ON THE FLYWHEEL COVER IS FREE FROM WEAR THAT MAY IMPAIR THE PROPER SEALING OF THE LUBRICATION PRESSURE ADJUSTMENT PISTON. THE HEAD LUBRICATION CHANNEL IS EQUIPPED WITH A SHUTTER JET; THIS GIVES A "LOW PRESSURE" HEAD LUBRICATION. THIS CHOICE WAS MADE TO REDUCE THE OIL TEMPERATURE IN THE SUMP.

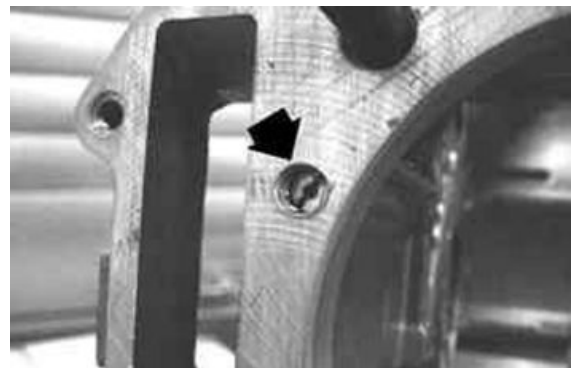

The jet clogging impairs the head lubrication and the timing mechanisms.

A jet failure causes a decrease in the main bearing and connecting rod lubrication pressure.

- Check that the surfaces exhibit no dents or deformations, with special attention to the crankcase coupling and the crankcase-cylinder surfaces.
- Any defects in the crankcase gasket or matching surfaces (see Flywheel cover coupling) can cause pressurised oil leaks, thereby affecting the connecting rod and main bearing lubrication pressure.
- Check the main bearing seats that limit axial clearance in the crankshaft show no signs of wear. For the dimensional check, refer to the instructions about checking the axial clearance and the dimensions on the crankshaft

## Inspecting the crankshaft plain bearings

- To obtain a good bushing lubrication it is necessary to have both an optimal lubricating pressure (4 bar) and a good oil flow rate; the bushings must be correctly positioned so as not to obstruct the oil supply channels.

- The main bushings are comprised of two half-bearings, one with holes and channels for lubrication whereas the other is solid.

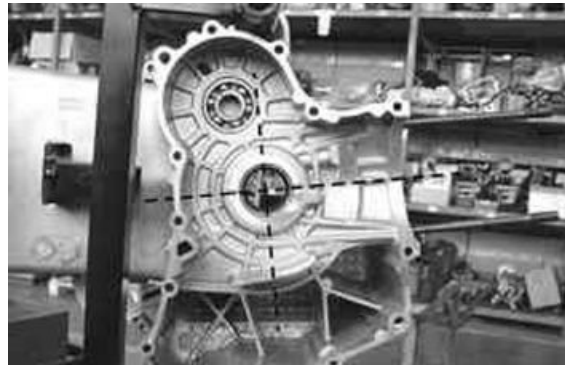

- The solid half-bearing is intended to stand the thrusts caused by combustion, and for this reason it is arranged opposite the cylinder.

- To prevent obstructions in the oil feeding channels, the matching surface of the two half-bearings must be perfectly perpendicular to the cylinder axis, as shown in the figure.

- The oil feeding channel section is also affected by the bushings driving depth compared with the crankshaft axial clearance of the limiting surface.

**N.B.**

**TO KEEP THE BUSHINGS ON THE CRANKCASE IN SUCH POSITION, DRIVING IS FORCED ON CAST-IRON RINGS INSERTED IN THE CASTING OF BOTH CRANKCASE HALVES.**

- Check the inside diameter of the main bushings in the three directions indicated in the diagram.

- Repeat the measurements for the other bushing half. see diagram.

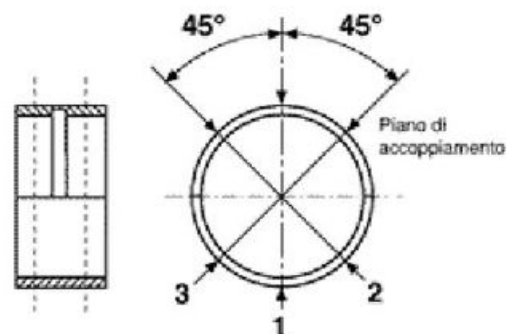

**N.B.**

**DO NOT TAKE THE MEASUREMENT ON THE TWO HALF-SHELL COUPLING SURFACE SINCE THE ENDS ARE RELIEVED TO ALLOW BENDING DURING THE DRIVING OPERATION.**

- The standard bushing diameter after driving is variable on the basis of a coupling selection.

- The bushing seats into the crankcases are classified into 2 categories as for the drive shaft Cat. 1 and Cat. 2.

- Bushings are divided into 3 categories according to their thickness. See the table below:

**CHECK THE BENCH BUSH**

Name	Description	Dimensions	Initials	Quantity
Type A - Red		1.982 - 1.987		
Type B - Blue		1.987 - 1.992		
Type C - Yellow		1.992 - 1.997		

## Coupling chart

### COUPLING THE SEMI-SHAFTS WITH THE SEMI-CHASSIS AND BUSHES

Name	Description	Dimensions	Initials	Quantity
Half-shaft category 1 - Bushings category B			Spare crankcase set-up FC1 - Dis. CM1033015001	
Half-shaft category 2 - Bushings category C			Spare crankcase set-up FC1 - Dis. CM1033015001	
Half-shaft category 1 - Bushings category A			Spare crankcase set-up FC2 - Dis. CM1033015002	
Half-shaft category 2 - Bushings category B			Spare crankcase set-up FC2 - Dis. CM1033015002	

**N.B.**

**FOR SERVICING WITH SPARE PARTS, MATCH THE SHAFT WITH TWO SHOULDERS OF CATEGORY 1 TO CRANKCASE FC1 (OR CATEGORY 2 TO CRANKCASE FC2).**

A spare crankcase cannot be combined with a driving shaft with mixed categories. Spare shafts have half-shafts of the same category.

**N.B.**

**TO REPLACE THE HALF-SHAFTS, REMOVE THE COUNTERSHAFT BEARINGS AS DESCRIBED ABOVE. REMOVE THE COMPLETE DRIVEN PULLEY AND THE ANTI-FLAPPING ROLLER FROM THE TRANSMISSION SIDE HALF-CRANKCASE, AS DESCRIBED IN CHAPTER "AUTOMATIC TRANSMISSION", AND THE HUB COVER WITH THE RELEVANT GEARS AND BEARINGS AS DESCRIBED IN CHAPTER "FINAL REDUCTION".**

## Countershaft

- Using a micrometer, measure the 2 bearings of the countershaft as shown in the figure.

**Characteristic**

**Standard diameter:**

17 - 0.01 - 0.02 mm



- Check that the water pump drive is not worn.

## Refitting the crankshaft

- Check that the oil pump and countershaft control gear are free from deformations or dents. Replace, if required.

**N.B.**

**IF YOU HAVE TO REPLACE THE OIL PUMP AND COUNTERSHAFT CONTROL GEAR IT IS NECESSARY TO REPLACE THE COUNTERSHAFT GEAR AS WELL.**

- Before installing the gear on the crankshaft, carefully clean the two matching surfaces removing any residues of LOCTITE from the holes using a brush.



Blow with compressed air and degrease the mounting holes on both surfaces to make the new LOCTITE grip.

Apply the recommended product to the holes again.

### Recommended products

#### Loctite 243 Medium strength threadlock

Loctite 243 medium-strength threadlock

- Repeat the same procedure for the 4 fastening screws.
- Insert the control gear on the crankshaft with the hole countersink visible.
- Tighten the 4 fastening screws to the prescribed torque.

**N.B.**

**TO AVOID DAMAGING THE SCREW CONTROL HEXAGON, IT IS PREFERABLE TO USE AN INSIDE HEXAGON SOCKET WRENCH.**

### Locking torques (N\*m)

#### Gear mounting on crankshaft screws 10 -12

- Lubricate the main bearing on the flywheel side half-crankcase.
- Lubricate the shim adjustment washer.
- Insert the shim adjustment washer on the crankshaft in its original position.
- Insert the special timing tool in the hole on the countershaft.



### Specific tooling

#### 020471Y Pin for countershaft timing

- Insert the crankshaft on the pin and into the bushing.
- Before inserting thoroughly, make the oil pump gear align with the control gear.
- Insert thoroughly and remove the special tool.



**N.B.**

**WHEN INSERTING THE SHAFT ON THE HALF-CRANKCASE, BE CAREFUL NOT TO DAMAGE THE MAIN BEARING WITH THE THREADED TANG OF THE CRANKSHAFT AND WITH THE TIMING CONTROL TOOTHED PINION.**

- Install the oil pump closing plate.
- Tighten the 2 flanged fastening screws to the prescribed torque.

### Locking torques (N\*m)

**Bulkhead screws for oil pump housing cover 8 - 10**



## Refitting the crankcase halves

- Remove the oil guard from the transmission side half-crankcase using a screwdriver.



- Install a new oil guard after lubricating it, using the special tool, arranging it at a 0.5 mm recess from the crankcase plane.

### CAUTION

**A WRONG POSITIONING OF THE OIL GUARD AFFECTS THE LUBRICATION OIL CIRCULATION.**

### Specific tooling

**020360Y Adaptor 52 x 55 mm**

**020376Y Adaptor handle**



- Insert the gasket on the flywheel side half-crankcase.

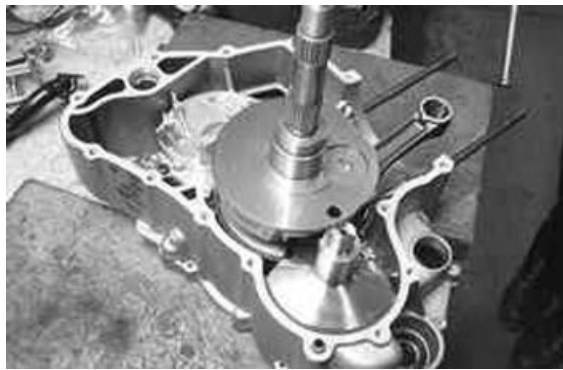

- Lubricate the main bearing on the transmission side half-crankcase.

- **Couple the 2 half-crankcases being careful not to damage the bushing on the transmission side half-crankcase with the threaded tang of the crankshaft.**

- Insert the engine support retain screw on the flywheel side half-crankcase without tightening.

- Insert the 14 fastening screws by arranging the single shorter screw «A» and the single longer screw «B» as shown in the figure.



- Tighten the screws thoroughly and tighten to the prescribed torque.
- Check that the crankshaft rotates freely.

**N.B.**

**REMOVE ANY EXCESS FROM THE CRANKCASE COUPLING GASKET ON THE CYLINDER PLANE, TO ENSURE BETTER SEALING PERFORMANCE.**

**Locking torques (N\*m)**

**Engine-crankcase coupling screws 11 ÷ 13**

- Install the thermal group (cylinder, head, piston) as described in section «Thermal group and timing system».

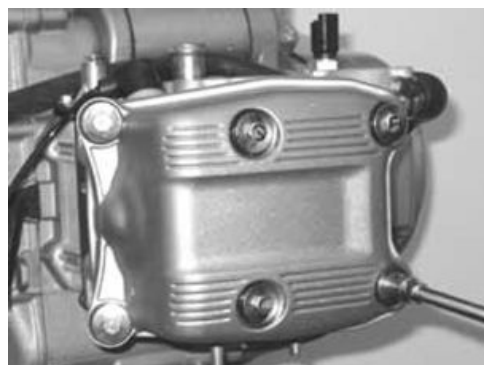



- Install the flywheel with start-up control as described in the "Flywheel and start-up" chapter.



- Install the flywheel cover with the cooling system sleeves, as described in the "Flywheel cover chapter".



- Install the complete driving pulley, the transmission cover and the relevant mesh filter and the outside transmission cover as described in the section "Automatic transmission".



**See also**

- [Flywheel cover](#)
- [Cylinder assy. and timing system](#)

**Lubrication**

**TECHNICAL SPECIFICATIONS**

**SUMP CAPACITY**

Specification	Desc./Quantity
Overhaul	1.7 l
Oil and filter replacement	1.5 l

**RECOMMENDED ENGINE OIL**

Product	Description	Specifications
AGIP CITY HI TEC 4T	Engine oil	SAE 5W-40, API SL, ACEA A3, JASO MA Synthetic oil

**OIL PUMP**

Specification	Desc./Quantity
Type	Trochoidal
Rotor washers	8 mm
Assembly clearances	Lobe ends 0.05-0.008 mm
External rotor radial clearance	0.05- 0.12 mm
Rotor axial clearance	0.025 - 0.065 mm

**BY-PASS**

Specification	Desc./Quantity
Type	with piston
Plunger diameter	13.9 - 0.039 -0.057 mm
Spring free length	62.5 mm
Calibration pressure	4 bar

**PRE-FILTER**

Specification	Desc./Quantity
Type	mesh, plastic

**OIL FILTER**

Specification	Desc./Quantity
Type	Paper with pressure relief and anti-drain back by-pass valves

**OIL MINIMUM PRESSURE INDICATOR LIGHT SWITCH**

Specification	Desc./Quantity
Calibration	0.3 - 0.6 bar

**HEAD LUBRICATION CONTROL JET**

Specification	Desc./Quantity
Diameter	1 ± 0.05 mm *

\* *Tightening torque 5÷7 N·m*

**PISTON COOLING NOZZLE**

Specification	Desc./Quantity
Diameter	0.8 ± 0.05 mm

**CRANKCASE VENTILATION CHECK**

Specification	Desc./Quantity
Device	metal reed valve and decantation chamber

Conceptual diagrams

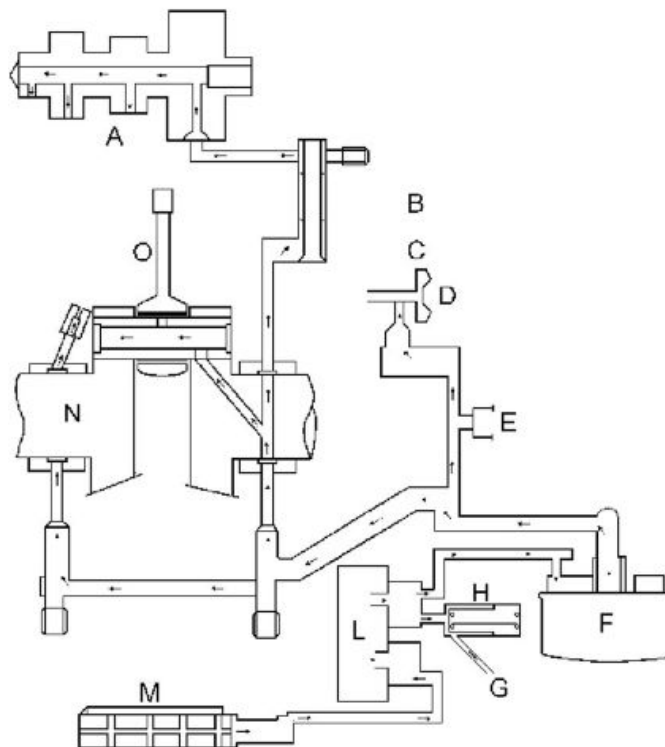

**PRINCIPLE DIAGRAM**

Specification	Desc./Quantity
A	Camshaft
B	Cylinder-head plane
C	Cylinder-crankcase plane
D	Water pump impeller
E	Minimum oil pressure sensor
F	Oil filter cartridge
G	To the oil sump
H	By-pass valve
L	Oil pump
M	Mesh pre-filter
N	Crankshaft
O	Connecting rod

**General characteristics**

The lubrication system is divided into two sections:

- High pressure
- Low pressure

The high pressure section includes all components located on the engine crankcase whereas the low pressure section only refers to the thermal group.

The trochoidal pump is installed in the sump and is controlled by a pair of gears.

To guarantee the integrity of the pump, a pre-filter is fitted.

This is a screw-in type pre-filter and the relevant plug serves at the same time as an engine oil drain plug.

The pump is controlled by means of a piston by-pass calibrated to 4 bar. This is located before the cartridge filter and both are installed on the flywheel cover, so that the seal of the filter is subject to the pressure of the circuit.

The by-pass located before the cartridge filter improves the operating conditions for the filter, particularly with cold oil.

The filter is equipped with an anti-drain back valve and a pressure relief valve; the latter intervenes when the filtering mass causes a pressure drop above  $1 \pm 0.2$  bar.

These conditions naturally occur only with cold oil and at high engine revs or if the filter is clogged.

The filtered oil is used to lubricate the water pump shaft and once at the engine crankcase, to lubricate the main bearings, the connecting rod head and the piston cooling nozzle, on the transmission-side bearing.

The main bearing on the transmission side is fitted with an oil seal and the respective drain line.

The supply line for the timing system comes from the flywheel-side bearing; the supply to the head is controlled by the respective spray jets in the engine crankcase.

The components of the timing system function with low-pressure oil lubrication.

The camshaft bearings are installed directly on the aluminium of the head; the camshaft axial clearance is partially compensated by the oil supplied to the smaller diameter bearing.

The camshaft supplies the lubricant to the rocking levers via the holes provided; these are installed in a position to ensure that the lubrication is maintained even after the scooter has stopped. This is achieved when the camshaft reaches its most usual and likely position when the engine is shut off.

The oil used to lubricate the head returns to the sump via the chain casing channel and therefore it also provides lubrication for the chain.

A one-way valve and a decantation chamber are used so that gases from the crankcase do not carry any oil. The one-way valve is a metal reed valve; the decantation chamber has a drainage hole. A failure in these components implies oil getting into the line supplying air to the engine.

Excessive oil vapours may result in clogged ducts on the throttle body.

In order to signal low oil pressure in the system, a pressure switch is used, located immediately after the oil filter outlet.

The lubrication circuit does not include the countershaft. The countershaft is lubricated by the oil transported by the gears or by the centrifugal effect of the crankshaft

The same applies to the piston or the pin, but in this case the cooling nozzle is particularly important.

---

## Diagnosis guide

**1** - Minimum oil pressure warning light on with hot engine.

AHEAD - go to 2

**2** - Remove the minimum pressure switch electric connector.

Check that the warning light turns off.

YES - go to 3 NO go to 11

**3** Check the actual oil pressure.

AHEAD - go to 4

**4** - Remove the switch and fit the special tool with the relevant gasket.

**Specific tooling**

**020193Y Oil pressure gauge**

**020434Y Oil pressure control fitting**

- Remove the dipstick with the oil filling cap and insert a cap fitted with the temperature probe supplied with the special tool. Insert the probe to feel contact with the crankcase bottom and pull back a few millimetres.

**Specific tooling**

**020331Y Digital multimeter**

AHEAD - go to 5



**5** - Measure the pressure with cold and idling engine.

**STANDARD VALUES**

Specification	Desc./Quantity
20°C Temperature 1400 rpm	

*approx. 4.5 bar*

**N.B.**

**RPM CAN BE MEASURED BOTH BY THE EXHAUST GAS ANALYSER AND BY THE DIAGNOSTIC TESTER**

**Specific tooling**

**020460Y Scooter diagnosis and tester**

YES go to 6 NO go to 12

**6** - Let the engine warm up and repeat the check with hot oil.

**STANDARD VALUES**

Specification	Desc./Quantity
80°C Temperature 1400 rpm	

*approx. 1.5 bar*

YES go to 7 NO go to 8

**7** - Replace the oil minimum pressure switch.

**8** - If pressure lower than 1.3 ÷ 1.5 bar is measured.

AHEAD go to 9

**9** - Replace the oil filter and repeat the pressure check with oil at 80°C.

YES go to 10 NO go to 13

**10** - The failure was fixed.

It is recommended to respect the suggested number of kilometres covered.

**11** - Check and restore the electrical system.

**12** - If pressure lower than 4 bar is measured.

AHEAD go to 9

**13** - Remove the flywheel cover and check the by-pass and the cover sealing gasket efficiency towards the case internal side, as described in the "Flywheel cover" chapter.

YES go to 14 NO go to 15

**14** - Check whether there is an irregular clearance on the crankshaft:

- axial clearance (see the "Crankcase and crankshaft" chapter)

- radial clearance, especially in the direction of the cylinder axis

- clearance according to the direction of rotation with the connecting rod in quadrature

YES go to 16 NO go to 17

**15** - Replace the faulty components ("Flywheel cover" chapter).

**16** - Overhaul the engine ("Crankcase and crankshaft" chapter).

**17** - Open the engine crankcase and remove the oil pump as described in the "Crankcase and crankshaft" chapter.

- Check the oil pump as described in the following pages.

- Check that the cooling nozzle and the timing system feeding jet are properly installed.

- Visually inspect the crankshaft couplings and their size ("Crankcase and crankshaft" chapter).

**N.B.**

**POTENTIAL IRREGULARITIES IN COUPLINGS AND THE TIMING SYSTEM COMPONENTS CANNOT BE DETECTED WHEN INSPECTING THE LUBRICATION PRESSURE. THEY MAY BECOME EVIDENT BY AN INCREASE IN NOISE.**

**N.B.**

**IN CASE OF IRREGULAR PRESSURE ON THE CRANKCASE, CARRY OUT A VISUAL AND DIMENSIONAL INSPECTION OF THE TIMING SYSTEM COMPONENTS (SEE "THERMAL GROUP AND TIMING SYSTEM" CHAPTER).**

---

## Oil pressure check

**1** - In case of oil leaks from the oil filter or from the flywheel cover coupling gasket, check the lubrication pressure.

AHEAD go to 2

**2** - Install the special tool.

### Specific tooling

**020193Y Oil pressure gauge**

---

**020434Y Oil pressure control fitting**

AHEAD go to 3

**3** - Check the system pressure with cold engine and medium - high speed.

Standard pressure < 6 bar

YES go to 4 NO go to 5

**4** - Replace the damaged components.

**5** - Check the working order of the adjustment by-pass (see "flywheel cover" chapter) and restore proper sliding.

**N.B.**

**STANDARD PRESSURES ARE OBTAINED USING OIL WITH THE PRESCRIBED VISCOSITY. A HIGHER VISCOSITY CAUSES AN INCREASE OF THE SYSTEM PRESSURE.**

**1** - If oil consumption is above 250 g/1000 km on a run-in engine, proceed as follows.

AHEAD go to 2

**2** - Check the presence of oil at the scavenge duct on the filter box.

YES go to 3 NO go to 4

**3** - Check the one-way reed valve and the decantation chamber drainage hole.

YES go to 5 NO go to 4

**4** - Check the thermal group seals (piston rings, valve guides and oil guards), see "Thermal group and Timing system" chapter.

**5** - Restore the valve or the drainage hole efficiency.

---

**Oil pump**

---

**Removal**

---

- Remove the closing plate of the oil pump housing by loosening the 2 retaining screws with their washers.



- 
- Remove the oil pump complete with the gearing by loosening the 2 retaining screws through the eyes machined in the gearing proper.



- 
- Remove the gasket.



- 
- Remove the two screws and the oil pump cover.



- 
- Remove the inside rotor retaining snap ring turning it to move the opening at the shaft face.





- Remove and wash the rotors thoroughly with petrol and compressed air.
- Extract the shaft with its gear and check that it is in good working order and free from wear.



- Reassemble the rotors in the pump body, keeping the two reference marks visible
- Insert the shaft with the gear and install the lock ring; then, turn it with the opening opposed to the shaft face.
- Check any irregular clearance between shaft and pump body.



- Using a thickness gauge, check the distance between the rotors in the position shown in the figure.

**Characteristic****Admissible limit clearance:**

0.012 mm



- Check the distance between external rotor and pump body; see figure.

**Characteristic****Admissible limit clearance:**

0.25 mm



- 
- Check the rotor axial clearance using a rectified bar as reference plane, as shown in the figure.

**Characteristic****Limit values admitted:**

0.1 mm



---

**Inspection**

- For tests on the oil pump, see the "Lubrication" chapter.



---

**Refitting**

- Make sure the gasket is in the correct position.

**N.B.****THE TOOTH OF THE GASKET MUST BE IN ITS SEAT.**

- Insert the oil pump with gear
- Insert the 2 retaining screws through the slots on the gear and tighten to the prescribed torque.

**N.B.****THE ASSEMBLY POSITION OF THE PUMP IS FIXED BY INSTALLATION OF THE SCREWS.**

Failure to observe the tightening torque may alter the coupling clearance of the rotors with the pump body.

**Locking torques (N\*m)**

**Screws fixing oil pump to crankcase 5 - 6**

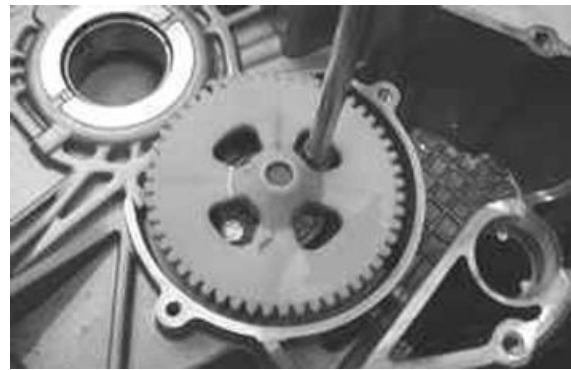

- Insert the countershaft with gearing into the fly-wheel-side half-crankcase.
- Install the special tool in the position shown in the figure.

**Specific tooling**

**020479Y Countershaft lock wrench**



- Keep the countershaft in position and insert the washer with the nut.
- Tighten the nut to the prescribed torque, using the recommended product.
- Remove the special tool.

**Recommended products**

**Loctite 243 Medium strength threadlock**

Loctite 243 medium-strength threadlock



**Locking torques (N\*m)**

**Countershaft fixing nut 25 ÷ 29**

- Lubricate the internal rotors.
- Check there are no signs of scoring or wear on the oil pump cover.
- If non-conforming values or signs of wear are found, replace the pump.
- Fit the pump cover in the position that permits the crankcase fixing screws to be aligned.
- Tighten the two fastening screws to the prescribed torque.

**Locking torques (N\*m)**



**Oil pump cover screws 0.7 ÷ 0.9**

---

## INDEX OF TOPICS

INJECTION

INJEC

**EMS injection system**

This vehicle is fitted with an integrated injection and ignition system.

Injection is indirect in the manifold through an electro-injector.

Injection and ignition are timed on the 4-stroke cycle using a tone wheel pivoted on the camshaft control and a reluctance variation sensor.

Combustion and ignition are managed on the basis of engine revs and throttle valve opening. Further corrections are made according to the following parameters:

- Coolant temperature.
- Intake air temperature
- Ambient pressure

The system implements an idle feeding correction with cold engine through a Stepper motor on a bypass circuit of the throttle valve. The control unit manages the Stepper motor and the injector opening time, thereby ensuring the idle steadiness and the proper combustion.

In all conditions of use, mixture preparation is managed by modifying the injector opening time.

The fuel supply pressure is kept constant based on the ambient pressure.

The **fuel supply circuit** consists of:

- Fuel pump
- Fuel filter
- Injector
- Pressure regulator

The pump, the filter and the regulator are placed inside the fuel tank on a single support.

The injector is connected by two pipes provided with quick couplings. This allows obtaining a continuous circulation, thereby avoiding the risk of fuel boiling. The pressure regulator is situated at the end of the circuit.

The fuel pump is controlled by the EMS control unit; this ensures the scooter safety

The **ignition circuit** consists of:

- HV coil
- HV cable
- Shielded cap
- EMS control unit
- Spark plug

The EMS control unit manages the ignition with optimum timing, ensuring the timing on the 4-stroke cycle (ignition only during compression).

The EMS injection/ignition system manages the engine function according to a pre-set program.

Should any input signals fail, an acceptable working order of the engine is ensured to allow the user to reach a service station.

Of course, this cannot happen when the rpm-timing signal is missing, or when the failure involves the control circuits:

- Fuel pump
- HV coil
- Injector

The control unit is provided with a self-diagnosis system connected to an indicator light in the instrument panel.



Failures are detected and restored by the diagnostic tester.

In any case, when the fault is no longer present, the data storage is automatically cleared after 16 cycles of use (cold start, running at regular engine temperature, stop).

The diagnostic tester is also required to adjust the idle mixture.



## Specific tooling

### 020460Y Scooter diagnosis and tester

The EMS injection-ignition system has a control function over the rpm indicator and the radiator cooling electric fan.

The EMS is connected to the anti-theft immobilizer system decoder.

In turn, the decoder is connected to a flashing diagnostic LED that also serves as deterrent.



The EMS control unit power supply is further controlled by the emergency switch and by the side stand switch, that is to provide further safety for the scooter.



---

## Precautions

1. Before fixing any part of the injection system, check to see if there are any registered faults. Do not disconnect the battery before checking for faults.
2. The fuel supply system is pressurised at 300 kPa (3 BAR). Before disconnecting the quick coupler of a pipe in the fuel supply system, check that there are no naked flames. Do not smoke. Act with caution to prevent spraying in the eyes.
3. When fixing electric components, operate with the battery connected only when actually required.
4. When functional checks are performed, check that the battery voltage is over 12V.
5. Before trying to start up, check to make sure there is at least two litres of fuel in the tank. Failure to respect this norm will damage the fuel pump.
6. If the scooter is expected to remain unused for a long time, refill the tank up to a little over half the level. This will ensure the pump will be covered by fuel.
7. When washing the vehicle, be careful with the electric components and wiring.
8. When an ignition fault is detected, start the checks from the battery and the injection system connections.
9. Before disconnecting the EMS control unit connector, perform the following operations in the following order:
  - Set the switch to «OFF»
  - Disconnect the batteryFailure to respect this norm may damage the control unit.
10. Do not invert the polarity when fitting the battery.
11. In order to prevent damages, disconnect and reconnect the EMS connectors only if actually required. Before reconnecting, check that the connectors are dry.
12. When carrying out electric inspections, do not force the tester probes into the connectors. Do not take measurements not specifically foreseen by the manual.
13. At the end of every check performed with the diagnostic tester, protect the system connector with its cap. Failure to respect this norm may damage the EMS control unit.
14. Before reconnecting the quick couplers of the power supply system, check that the terminals are perfectly clean.

---

## Terminals setup

Layout of the system-side connectors and the connectors on the electronic control unit.



**ELECTRONIC CONTROL UNIT SIDE**



**SYSTEM SIDE**

**ELECTRONIC CONTROL UNIT EMS**

	<b>Specification</b>	<b>Desc./Quantity</b>
1	Throttle potentiometer power supply	+5 V
2	- Lambda probe	
3	Rpm indicator / consumption counter	
4	Engine temperature	(+)
5	86 electric fan remote control switch	
6	Stepper motor	Stepper motor
7	Engine rpm sensor	
8	+ Lambda probe	
9	EMS diagnostic connector	
10	EMS diagnostic connector	
11	Throttle potentiometer signal	
12	Engine rpm sensor	
13	Injector control	(negative)
14	Stepper motor	Stepper motor
15	Instrument panel	(injection warning light- negative)
16	Decoder (serial)	Overturn sensor
17	Base power supply	(positive)
18	Air temperature sensor	(+)
19	85 remote control switch	(pump - injector - h.v. coil) (-)
20	H.V. coil	(negative control)
21	Stepper motor	Stepper motor
22	Sensor power supply	(-)
23	Control unit negative	
24	Stepper motor	Stepper motor
25	Turn indicator device	
26	Continuous power supply	(positive)

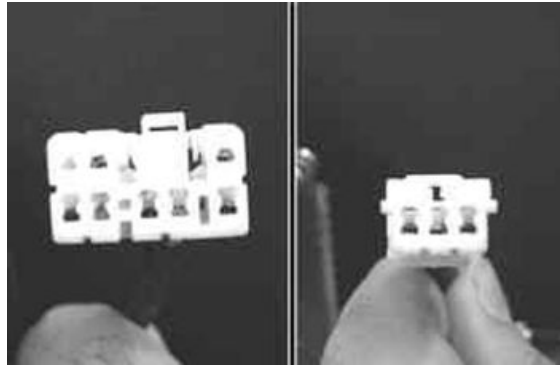

### **IMMOBILIZER DECODER**

	<b>Specification</b>	<b>Desc./Quantity</b>
1	-	
2	Immobilizer LED control	(negative)
3	Base power supply	(positive)
4	Negative	
5	-	
6	Electronic control unit EMS	(serial)
7	-	
8	Continuous power supply (positive)	Immobilizer aerial

EMS circuit diagram

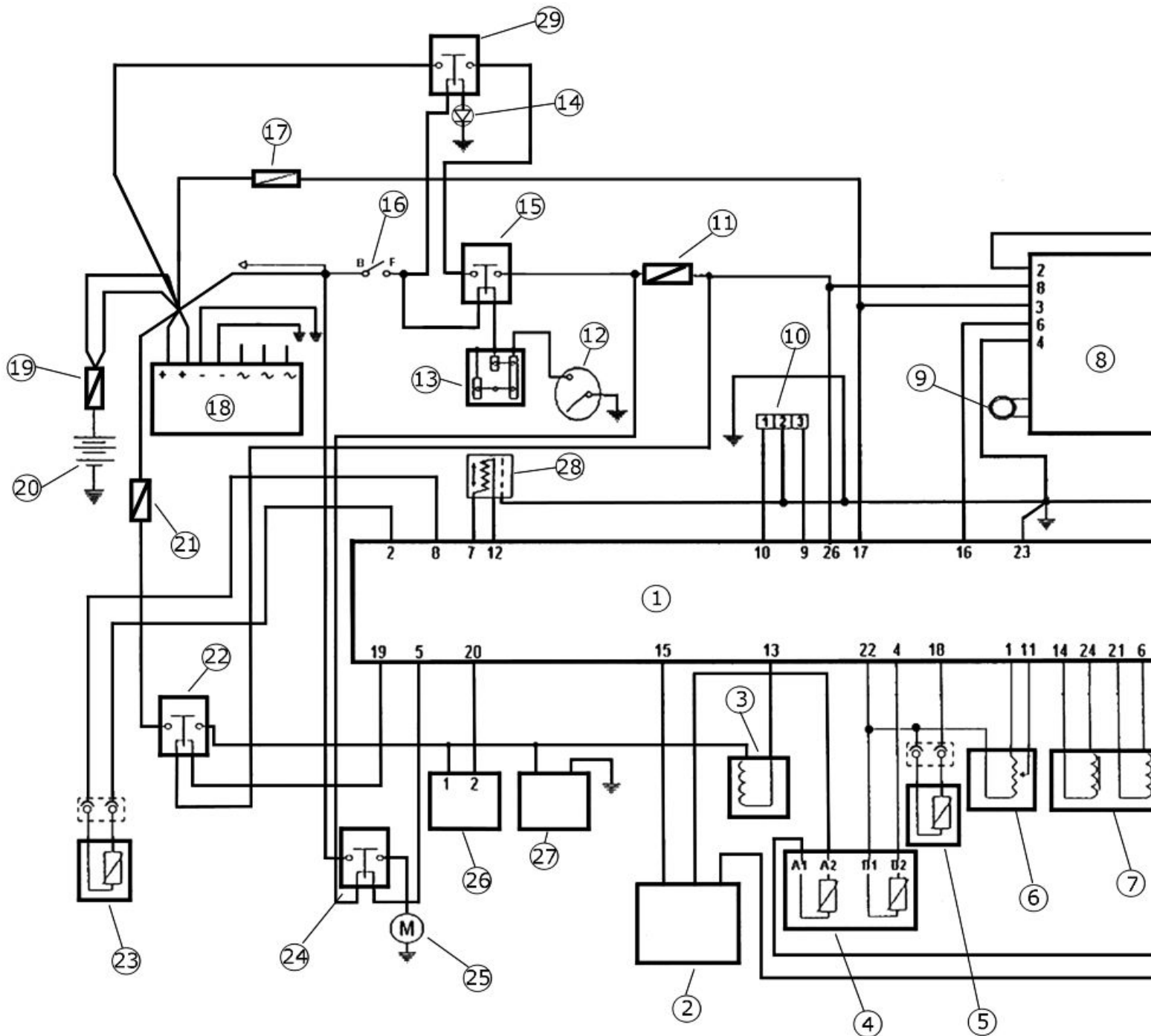

EMS CIRCUIT DIAGRAM

Specification	Desc./Quantity
1	EMS electronic injection control unit
2	Instrument panel
3	Fuel injector
4	Coolant temperature sensor
5	Air temperature sensor
6	Throttle potentiometer
7	Stepper motor

	Specification	Desc./Quantity
8	Immobilizer decoder	
9	Immobilizer aerial	
10	EMS diagnostic socket	
11	Fuse No. 4 (5A)	
12	Stand switch	
13	Engine stop switch	
14	Diode 1A	
15	Engine stop remote control switch	
16	Key switch contacts	
17	Fuse No. 3	5A
18	Voltage regulator	
19	Main fuse (30A)	
20	Battery	12V - 12 Ah
21	Fuse No. 2 (10A)	
22	Electronic control unit remote control switch	
23	Lambda sensor	
24	Electric fan remote control	
25	Electric fan	
26	HV coil	
27	Fuel pump	
28	Engine rpm sensor	
29	Main remote control switch	

## Troubleshooting procedure

This section makes it possible to find what solutions to apply when troubleshooting.

1 - A failure of the EMS system is more likely to be due to the connections than to the components.

Before searching the EMS system for failures, perform the following checks:

### SUGGESTION FOR TROUBLESHOOTING

	Specification	Desc./Quantity
1	1. Power supply	- Battery voltage - Burnt fuse - Remote control switches - Connectors
2	2. Chassis earth	
3	3. Fuel supply	- Faulty fuel pump - Dirty fuel filter
4	4. Ignition system	- Faulty spark plug - Faulty coil - Faulty screened cap
5	5. Intake circuit	- Dirty air filter - Dirty by-pass circuit - Faulty stepper motor
6	6. Other	- Wrong distribution timing - Wrong idle speed carburetion - Wrong reset of the throttle valve position sensor

2 - Failures to the EMS system may depend on loosened connectors. Make sure that all connections are properly implemented.

Check the connectors being careful of the following: 1. check that terminals are not bent. check that connectors are properly engaged.

Check whether the failure changes if the connector is slightly vibrating.

3 - Before replacing the EMS control unit, check the whole system carefully.

If the fault is fixed by replacing the EMS control unit, install the original control unit again and check whether the fault occurs again.

4 - For troubleshooting, use a multimeter with an internal resistance of more than 10KΩ/V.

Improper instruments may damage the EMS control unit.

The instruments to be preferred have a definition of more than 0.1V and 0.5Ω and an accuracy of more than ± 2%.

## Engine does not start

### ENGINE DOES NOT START IF ONLY PULLED

Possible Cause	Operation
Immobiliser enabling signal	System not encoded System not efficient, repair according to the indications of the self-diagnosis
Presence of faults detected by the self diagnosis	Pump relay HV coil Injector revolution timing sensor
Fuel supply	Fuel in the tank Fuel pump activation Fuel pressure (low) Injector capacity (low)
Power to the spark plug	Shielded spark-plug cap HV coil (secondary insulation)
Parameter reliability	Coolant temperature Distribution timing - injection ignition Intake air temperature
End of compression pressure	End of compression pressure

## Starting difficulties

### ENGINE START-UP PROBLEMS

Possible Cause	Operation
Presence of faults detected by the self diagnosis	Pump relay H.V. coil Injector revolution timing sensor Air temperature Coolant temperature. Atmospheric pressure
Start up engine speed	Starter motor and remote control Battery Ground connections
End of compression pressure	End of compression pressure
Power to the spark plug	Spark plug Shielded cap HV coil Rpm-timing sensor Ignition advance
Fuel supply	Fuel pressure (low) Injector capacity (low) Injector seal (poor)
Correctness of the parameters	Coolant temperature Stepper throttle valve position intake air temperature (steps and actual opening) Cleaning of the auxiliary air pipe and throttle valve; air filter efficiency

## Engine stops at idle

### ENGINE DOES NOT IDLE/IDLE IS UNSTABLE/IDLE IS TOO LOW

Possible Cause	Operation
Presence of faults detected by the self diagnosis	Pump relay H.V. coil Injector revolution timing sensor Air temperature Coolant temperature. Atmospheric pressure
Ignition efficiency	Spark plug Ignition timing
Correctness of the parameters	Throttle valve position sensor Stepper Coolant temperature sensor Intake air temperature sensor
Intake system cleaning	Air filter Diffuser and throttle valve Additional air pipe and Stepper
Intake system sealing (infiltrations)	Intake manifold - head Throttle body - manifold Intake sleeve Filter box
Fuel feed (low pressure)	Fuel pump Pressure regulator Fuel filter Injector capacity

## Engine does not rev down

### ENGINE DOES NOT RUN AT IDLE/IDLE TOO HIGH

Possible Cause	Operation
Presence of faults detected by the self diagnosis	Pump relay H.V. coil Injector revolution timing sensor Air temperature Coolant temperature. Atmospheric pressure
Ignition efficiency	Ignition timing
Correctness of the parameters	Throttle valve position sensor Stepper Coolant temperature sensor Intake air temperature sensor
Intake system sealing (infiltrations)	Intake manifold - head Throttle body - manifold Intake sleeve Filter box
Fuel feed (low pressure)	Fuel pump Pressure regulator Fuel filter Injector capacity

## Exhaust backfires in deceleration

### EXHAUST BACKFIRES WHEN DECELERATING

Possible Cause	Operation
Fault detected by autodiagnosis	Pump relay H.V. coil Injector

Possible Cause	Operation
Correctness of the parameters	revolution timing sensor Air temperature Coolant temperature Atmospheric pressure Lambda probe
	Throttle valve position sensor Stepper Coolant temperature sensor Intake air temperature sensor
Intake system sealing (infiltrations)	Intake manifold - head Throttle body - manifold Intake sleeve Filter box
Fuel feed (low pressure)	Fuel pump Pressure regulator Fuel filter Injector capacity
Exhaust system sealing (infiltrations)	Manifold - head Manifold - muffler Analyser socket Muffler welding

### Engine revs irregularly

#### ENGINE RUNS IRREGULARLY WITH THROTTLE SLIGHTLY OPEN

Possible Cause	Operation
Fault detected by autodiagnosis	Pump relay H.V. coil Injector revolution timing sensor Air temperature Coolant temperature Atmospheric pressure Lambda probe
Intake system cleaning	Air filter Diffuser and throttle valve Additional air pipe and Stepper
Intake system seal	Intake sleeve Filter box
Ignition system	Spark plug wear check
Parameter reliability	Throttle valve position signal Coolant temperature indicator Intake air temperature indicator Ignition advance
TPS reset successful	TPS reset successful

### Poor performance at full throttle

#### ENGINE POOR AT FULL POWER/ENGINE RUNS IRREGULARLY WHEN TIMED

Possible Cause	Operation
Fault detected by autodiagnosis	Pump relay H.V. coil Injector revolution timing sensor Air temperature Coolant temperature Atmospheric pressure Lambda probe
Spark plug power supply	Spark plug Shielded cap HV cable HV coil
Intake system	Air filter

Possible Cause	Operation
Parameter reliability	Filter box (sealing)
	Intake sleeve (sealing)
Fuel supply	Throttle valve position signal
	Coolant temperature indicator
	Intake air temperature indicator
	Ignition advance
	Fuel level in the tank
	Fuel pressure
	Fuel filter
	Injector capacity

## Engine knocking

### KNOCKING (AT THE HEAD)

Possible Cause	Operation	
Fault detected by autodiagnosis	Pump relay	
	H.V. coil	
	Injector	
	revolution timing sensor	
	Air temperature	
	Coolant temperature	
	Atmospheric pressure	
	Lambda probe	
	Ignition efficiency	Spark plug
	Parameter reliability	Throttle valve position signal
Coolant temperature indicator		
Intake system seal	Intake air temperature indicator	
	Ignition advance	
TPS reset successful	Intake sleeve	
Fuel supply	Filter box	
	TPS reset successful	
	Fuel pressure	
	Fuel filter	
	Injector capacity	
	Fuel quality	
Selection of the cylinder base gasket thickness	Selection of the cylinder base gasket thickness	

## Decoder master-box circuit

This section describes the operations to be carried out to check the power supply circuit.

### Constant supply circuit check

The decoder basic power supply is necessary for the deterrent flashing management. The injection control unit power supply is necessary for the Stepper motor management.

A power supply failure disables both ignition and injection.

In case of power supply faults, the diagnostic tester gives the information "NO REPLY FROM THE CONTROL UNIT".

To carry out the check, proceed as follows:

#### Specific tooling

**020460Y Scooter diagnosis and tester**



**1** - Check whether the immobiliser system LED indicates that the switch is in position "ON" and that the deterrent flashing is on.

YES go to 2 NO go to 7

**2** - The decoder is properly programmed.

YES go to 3

**3** - Switch set to "ON" with side stand raised and emergency switch set to "OFF". The injection telltale light turns on for about 3 seconds.

YES go to 5 NO go to 4

**4** - Check the instrument unit and its power supply.

YES go to 3

**5** - Set the emergency switch to "RUN". The injection telltale light comes on for about 5 seconds.

YES go to 6 NO go to 7

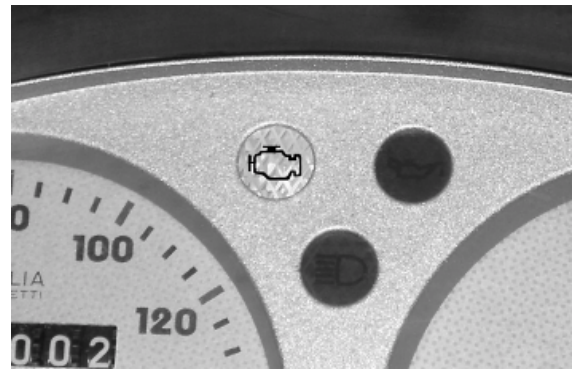

**6** - The injection control unit is certainly powered.

**7** - Check the condition of fuse No. 3 (5 A) located in the fuse holder under the right-hand fairing.

YES go to 10 NO go to 8

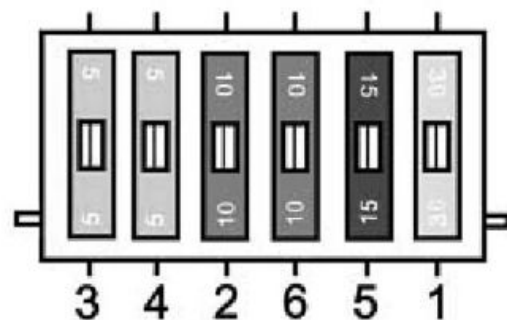

**8** - Fix any wiring short circuits and replace the fuse.

YES go to 1 NO go to 9

**9** - Check any short circuit on decoder or control unit and replace, if necessary.

YES go to 1

**10** - Place the special tool between control unit and power supply system. Disconnect the main decoder connector and check the following conditions:

Terminal no. 3= battery positive

Terminal no. 4= battery negative

YES go to 11 NO go to 13

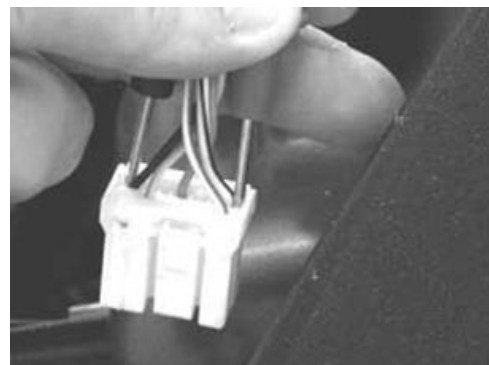

**Specific tooling**

**020481Y Control unit interface wiring**

**11** - Decoder with proper base power supply.

Use the special tool to check the control unit power supply:

Pin 17 = battery positive

Pin 23 = battery negative

YES go to 12 NO go to 13

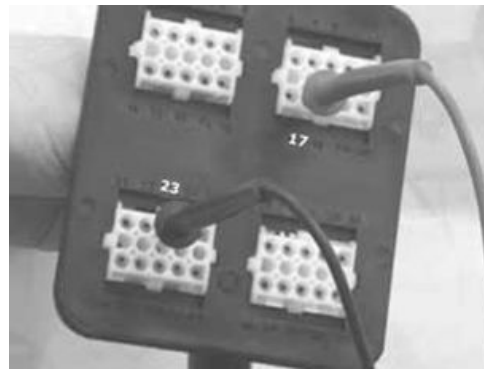

**12** - Control unit with proper base power supply.

**13** - If the battery negative is not present, check continuity between Pin 23 of the special tool and earth.

Detect the presence of the battery positive on Pin 17 of the special tool and on pin 3 of the decoder connector.

YES go to 12 NO go to 14

YES go to 11

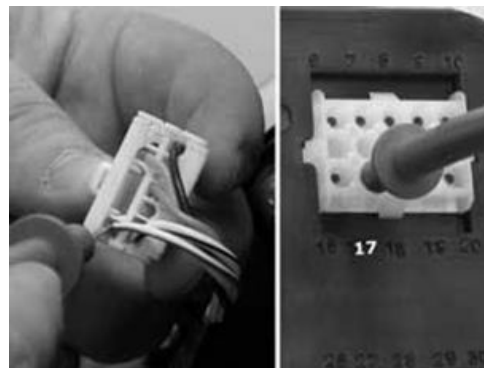

**14** - Fix the cable harness.

## Key-switch power supply circuit check

A failure of the constant power supply disables both ignition and injection functions. In case of power supply faults, the diagnostic tester gives the information "NO REPLY FROM THE CONTROL UNIT".

### Specific tooling

#### 020460Y Scooter diagnosis and tester

**1** - Check whether the immobilizer system LED indicates switching to "ON"

YES go to 2 NO go to 4

**2** - Raise the side stand. Set the emergency switch to "OFF". Turn the key switch to "ON". Set the emergency switch to "RUN". Check whether the injection telltale light turns on for 5 seconds

YES go to 3 NO go to 4



- 3 - Continuous power supplies are regular
  - 4 - Check the working order of the fuse no. 4 and 5 located in the fuse holder on the right side.
- YES go to 5 NO go to 6

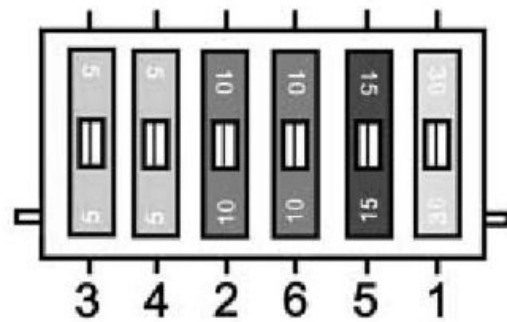

- 5 - Place the special tool between control unit and injection system.
- YES go to 7

**Specific tooling**

**020481Y Control unit interface wiring**

- 6 - Fix any short circuits and replace the fuse. Check decoder and control unit, if necessary
- YES go to 1
- 7 - Disconnect the main decoder connector and check the following conditions: switch set to "ON", switch to "RUN" and side stand raised
- Terminal no. 8 = battery positive  
Terminal no. 4= battery negative
- YES go to 8 NO go to 10



- 8 - Decoder with proper continuous power supply. Use the special tool to check the control unit continuous power supply. Switch set to "ON", switch to "RUN" and side stand raised.
- Pin 26 = battery positive  
Pin 23 = battery negative
- YES go to 9 NO go to 10

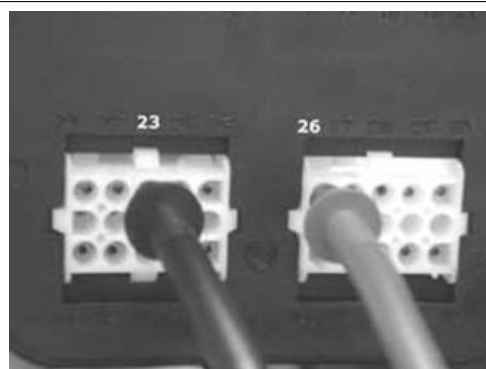

**Specific tooling**

**020481Y Control unit interface wiring**

**9** - Control unit with proper continuous power supply.

**10** - If only one component is not powered check the relevant connector. If the problem involves both the decoder and CPU check the continuity of the decoder CPU power supply line.

Pin 26 electronic control unit - Pin 87 engine stop remote control switch = continuity

Pin 8 decoder - Pin 87 engine stop remote control switch = continuity

YES go to 12 NO go to 11

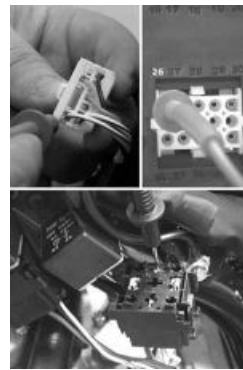

**11** - Fix the cable harness or the connection

YES go to 10

**12** - Proper continuous power supply

YES go to 13

**13** - Check the connector and the continuity of the key switch set to "ON"

Pin 1 - 2 = continuity

YES go to 14

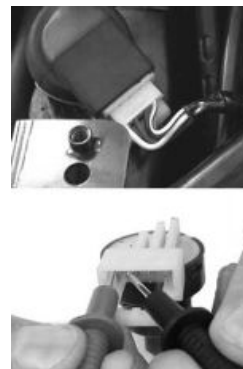

**14** - Check the engine stop remote control switch connector and the switch efficiency.

The connector can be recognised by its larger section white lead.

85 - 86 = approx. 70W

YES go to 15

**N.B.**

**CHECK THE COIL RESISTANCE**

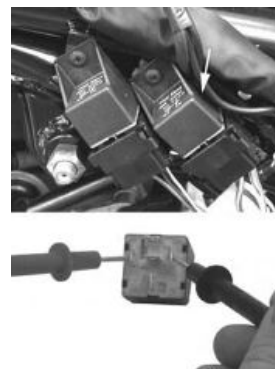

**15** - Check the signal circuit:

- emergency switch and connector
- side stand switch and connector

YES go to 16

**16** - Check the cable harness continuity. Check the utility control main remote control switch.

Disconnect the master remote control switch.

Check the diode installed on the earth connection of the main remote control switch pickup.

86 - earth = continuity with high resistance (connect the tester: positive with 86; negative with earth).

When the polarity is inverted there should be no continuity.

### Diagnostic circuit

\* CONNECTOR FOR DIAGNOSTIC TESTER

A = INJECTION CONTROL UNIT

Connect the diagnostic tester.

### Specific tooling

020460Y Scooter diagnosis and tester

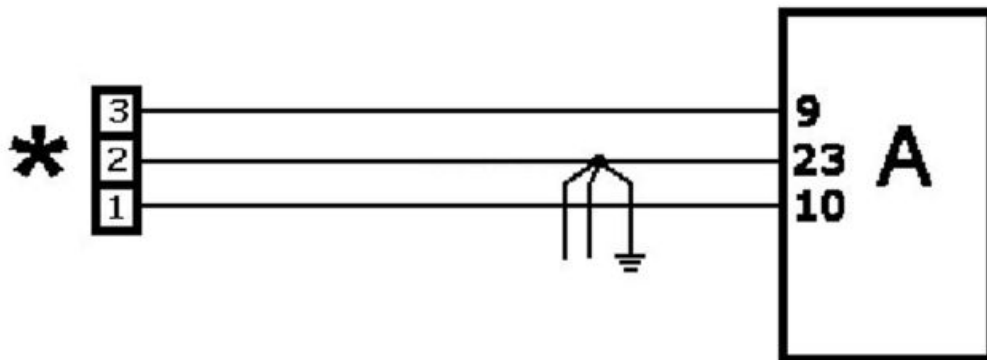

If the diagnostic tester displays «No reply from the control unit», disconnect the continuous power supply for 10 seconds and switch to «ON» again; if the message is still displayed, proceed as follows:

1 - Check the diagnostic tester connections.

YES go to 2 NO go to 3



2 - Check the control unit base and continuous power supplies.

YES go to 4

3 - Restore

4 - Place the special tool between control unit and system. Keep the control unit disconnected.

YES go to 5

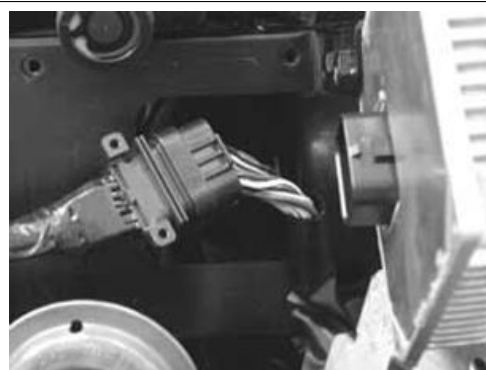

### Specific tooling

020481Y Control unit interface wiring

5 - Check the following conditions:

PIN 1 diagnostic socket - PIN 10 control unit = continuity

PIN 2 diagnostic socket - PIN 23 control unit = continuity with earth

PIN 3 diagnostic socket - PIN 9 control unit = continuity

10 - 23 = insulation (>1 MΩ)

9 - 23 = insulation (>1 MΩ)

YES go to 6 NO go to 7

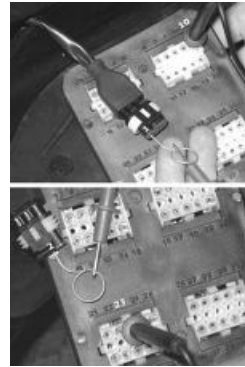

6 - The circuit is in good working order. Check the control unit.

7 - Fix the interruption or short-circuit.

### Injection warning light circuit

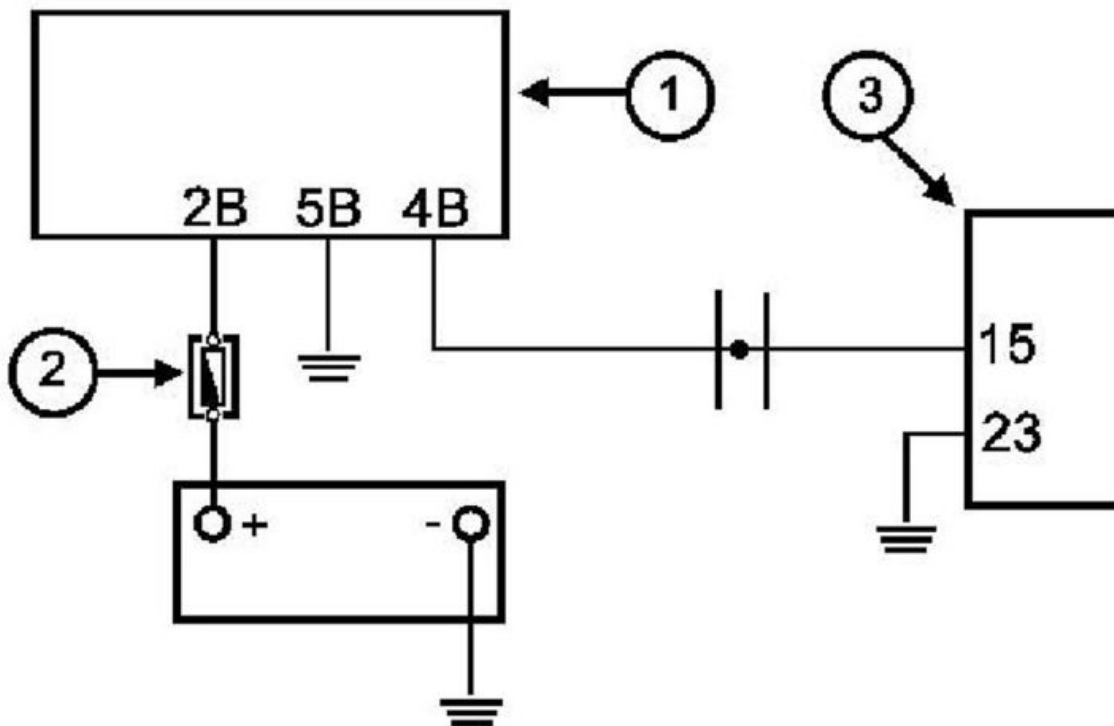

**CIRCUIT LAYOUT**

	Specification	Desc./Quantity
1	Instrument panel	
2	Fuse	7.5 A
3	Electronic control unit	

[P]

	Specification	Desc./Quantity
1	TERMINAL: 15 - 23	<b>CONDITIONS:</b> DURING THE CHECK - Switch set to "ON"

Specification	Desc./Quantity
2	- Side stand raised - Switch to "RUN" <b>STANDARD VALUES</b> : 0 V
TERMINAL: 15 - 23	<b>CONDITIONS: AFTER THE CHECK</b> - Switch set to "ON" - Side stand raised - Switch to "RUN" <b>STANDARD VALUES</b> : Battery voltage

The injection telltale light is controlled upon every switching to "ON" by the 3-second timing generated by the digital instrument. This step is normally interrupted by the injection control unit control. The timing lasts 5 seconds.

The diagnostic tester is not programmed to check this circuit.

Proceed as follows:

**Specific tooling**

**020460Y Scooter diagnosis and tester**

1 - Turn the switch to the "ON" position Turn the emergency switch to position "RUN". Keep the side stand raised. Make sure the light goes on for 5 seconds.

YES go to 2 NO go to 3

2 - The system is working.

3 - Put the special tool between the control unit and system.

YES go to 4

**Specific tooling**

**020481Y Control unit interface wiring**

4 - Switch in «ON» position Emergency switch on «RUN».

Side stand up Wait more than 5 seconds.

15 - 23 = battery voltage

YES go to 5 NO go to 6

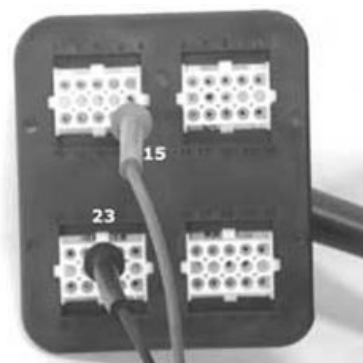

5 - Check the control unit connector. Check the control unit.

6 - Check the continuity between pin 15 of the CPU and the brown-black wire of the 6 input connector of the instrument unit.

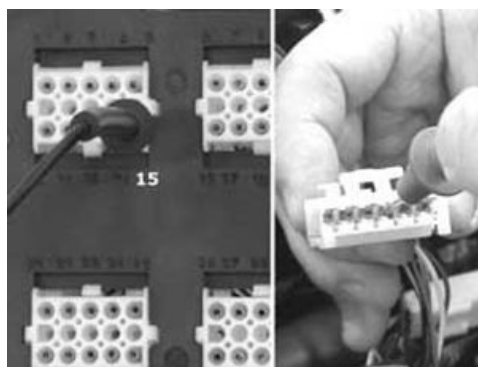

The injection ECU manages the negative of the light. The light must go off after the initial check. The light goes on again when the ECU self-diagnosis detects a fault. When the fault disappears the light

goes back off, however, the related operating tests need to be carried out. The light can go on whether the engine is able to run or not.

## Fuel supply system

Fuel is fed to the injector by a pump, a filter and a pressure regulator integrated with the fuel level indicator inside the tank.



The pump unit is connected to the injector by:

2 semi-flexible pipes

4 quick unions

1 T union with O-ring and retain bracket for the injector

The pipes are crossed and fixed to the intake manifold to prevent wear of the quick unions connected to the T union for the injector.

### N.B.

**BEFORE WORKING ON THE FUEL SUPPLY SYSTEM, CAREFULLY CLEAN THE PARTS TO PREVENT DAMAGING THE FAST-RELEASE COUPLING SEAL OR TO PREVENT DIRT GETTING INTO THE DUCTS.**

### CAUTION

**THE SYSTEM IS UNDER PRESSURE.  
DO NOT SMOKE DURING ANY OPERATION.  
PREVENT ANY FUEL SPRAYING.**

### WARNING

- **BEFORE STARTING THE ENGINE, CHECK WHETHER THERE IS FUEL IN THE TANK.**
  - **DO NOT USE THE SCOOTER IN RESERVE FOR A LONG TIME, UP TO THE POSSIBILITY OF RUNNING OUT OF FUEL.**
  - **IF THE SCOOTER IS EXPECTED TO REMAIN UNUSED FOR A LONG TIME, REFILL THE TANK AT LEAST TO HALF THE LEVEL.**
- FAILURE TO OBSERVE THESE RULES CAN DAMAGE THE PUMP.**



Circuit diagram

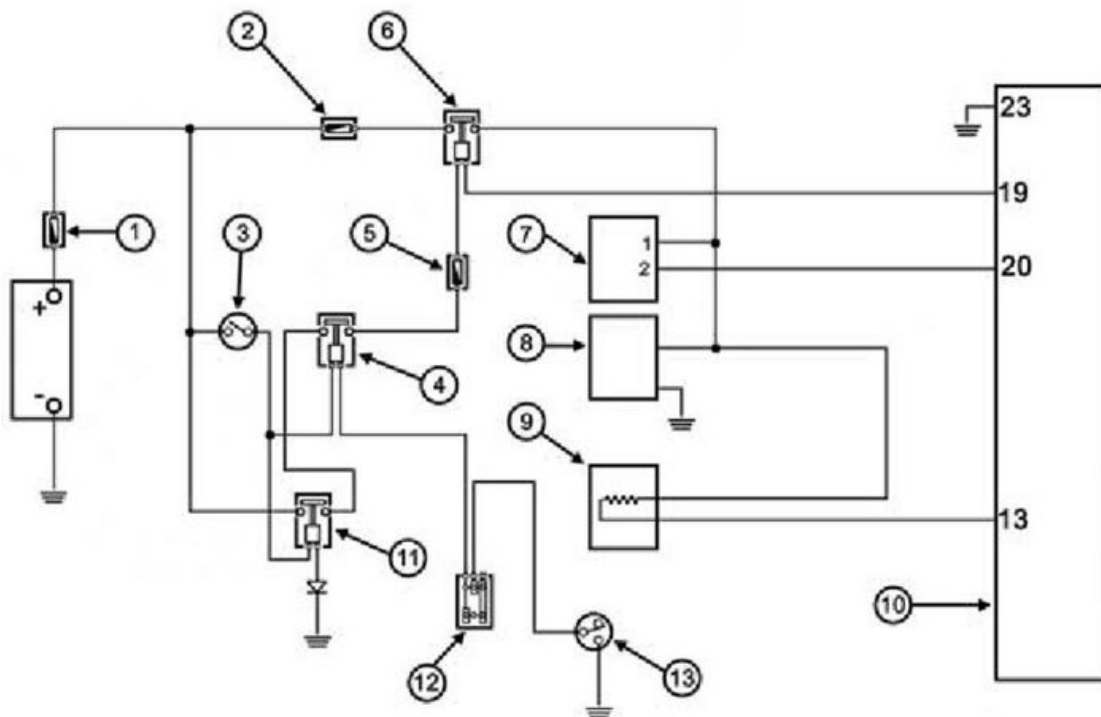

**CIRCUIT LAYOUT**

	Specification	Desc./Quantity
1	Fuse	30A
2	Fuse	10 A
3	Switch	
4	Engine stop remote control switch	
5	Fuse	5A
6	Control unit remote control switch	
7	HV coil	
8	Fuel pump	
9	Injector	
10	Electronic injection control unit	
11	Main remote control switch	
12	Engine stop switch	
13	Stand switch	

**Removing the injector**

N.B.

**ONLY REMOVE THE INJECTOR FROM THE MANIFOLD IN THE EVENT OF A PROVEN DEFECT. OPERATING TEST OF THE INJECTOR MUST BE PERFORMED WITH THE INJECTOR INSTALLED ON THE MANIFOLD (SEE "INJECTION").**

- To remove the injector, remove the central set screw of the "T" shunt acting as a support for the injector.



- Remove the injector from the manifold.



- Once the engine is repaired check the CO% value again while idling to make sure it is within the prescribed limits. If the CO% is not in conformity, proceed with calibration as described in the "Carburetion adjustment" chapter.

## Refitting the injector

Carefully check to make sure the components are clean.

- Fit new O-rings and grease them.
- Apply the recommended product to the set screws and tighten to the prescribed torque.

### Recommended products

**Loctite 243 Medium strength threadlock**

Loctite 243 medium-strength threadlock

### Locking torques (N\*m)

injector fixing screw 3 ÷ 4

N.B.

**ONCE THE ENGINE IS REPAIRED CHECK THE CO% VALUE WHILE IDLING TO MAKE SURE IT IS WITHIN THE PRESCRIBED LIMITS. IF THE CO% IS NOT IN CONFORMITY, PROCEED WITH CALIBRATION AS DESCRIBED IN THE ADJUSTING IDLE CARBURETION PARAGRAPH.**



## Removing the butterfly valve

N.B.

**THE THROTTLE BODY IS A PART WHICH INCLUDES VARIOUS COMPONENTS AND IS USUALLY SUPPLIED COMPLETE. TO TEST THESE COMPONENTS SEE THE "INJECTION" CHAPTER.**

- Remove the 3 retaining screws indicated in the figure.



**CAUTION**

**THE THROTTLE BODY COMES PRE-CALIBRATED. TAMPERING WITH THE THROTTLE STOP REGISTER IS TO BE ABSOLUTELY AVOIDED. THIS REGISTER HAS BEEN SEALED FOR THIS PURPOSE. FOR PROBLEMS WITH IDLING SEE THE "INJECTION" CHAPTER.**

**N.B.**

**REMOVAL OF THE THROTTLE BODY CAN BE EFFECTED WITH THE MANIFOLD ON OR OFF THE ENGINE.**

- Make sure the seal rims on the coupling surfaces between the manifold-throttle body and manifold-head are in good condition.



**CAUTION**

**IF AIR GETS IN IT CAN JEOPARDISE THE OPERATION OF THE INJECTION SYSTEM, ESPECIALLY WHEN THE ENGINE IS IDLING.**

- Make sure the throttle valve and related conduit are clean.
- Make sure the supplementary air channel managed by the Stepper motor is clean.

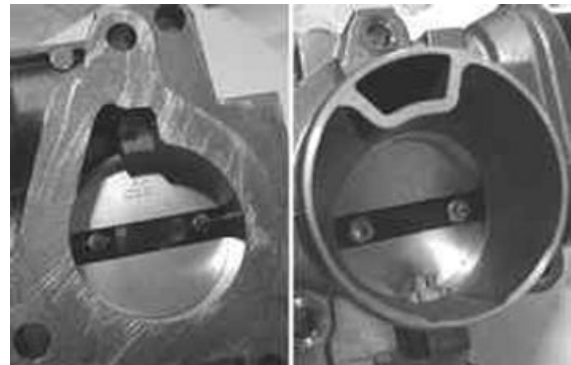

**N.B.**

**IF THE THROTTLE BODY IS REPLACED RESET THE T.P.S. AND ADJUST THE CO%. ONCE THE ENGINE IS REPAIRED CHECK THE CO% VALUE WHILE IDLING TO MAKE SURE IT IS WITHIN THE PRESCRIBED VALUES. IF THE CO% IS NOT IN CONFORMITY, PROCEED WITH CALIBRATION AS DESCRIBED IN THE ADJUSTING IDLE CARBURETION CHAPTER.**

## Refitting the butterfly valve

- Carry out the removal operations but in reverse order, tighten the 3 fixing screws to the prescribed torque.

### Locking torques (N\*m)

Throttle body fixing screws 11 ÷ 13



---

## Pump supply circuit

The control unit starts the pump in the following conditions:

- by setting the switch to «**ON**» with the emergency switch to «**RUN**» and side stand raised. The pump does not supply.
- If the rpm-timing signal is received. Continuous supply.

The initial timing is useful to bleed the system especially after a stop with engine in temperature. In these conditions, the fuel altered by boiling will be mixed with that in the tank.

During use, the pump operation will be subject to the engine speed.

---

## Circuit check

Proceed as follows:

**1** - Set the switch to "ON" with emergency switch to "RUN" and side stand raised. The pump rotates for 2 seconds.

YES go to 2 NO go to 3

**2** - Try to start up. Check that the engine speed matches the pump rotation.

YES go to 4 NO go to 5

**3** - The pump does not rotate, or it rotates uninterruptedly.

YES go to 5

**4** - The pump power supply is conforming.

**5** - Connect the diagnostic tester to the scooter system.

YES go to 6

### Specific tooling

**020460Y Scooter diagnosis and tester**

**6** - Try to start up. Select the function "**ERRORS**" in the menu. Check whether there are any failures.

YES go to 7 YES go to 8 NO go to 28

**7** - Pump control relay circuit failure.

YES go to 9



**8** - Failure of:

- injector
- H.V. coil
- Signals panel

YES go to 18



**9** - The control unit has detected a failure on the line of pin 19

YES go to 10 YES go to 11

**10** - Line to earth. In this case, the pump always starts to rotate if there is a continuous power supply.

YES point 12

**11** - Interrupted line. The relay cannot control the pump feeding

YES go to 13

**12** - Check and restore the earth insulation of the control unit line 19 and of the pump remote control switch line 85.

YES go to 14

**13** - Install the special tool between control unit and the injection system.

YES go to 15

### Specific tooling

#### 020481Y Control unit interface wiring

**14** - Delete the code and check from the beginning.

**15** - Set the switch to "ON" with switch to "RUN" and side stand raised. Wait more than two seconds and check the following conditions:

19 - 23 = battery voltage

YES go to 16 NO go to 17

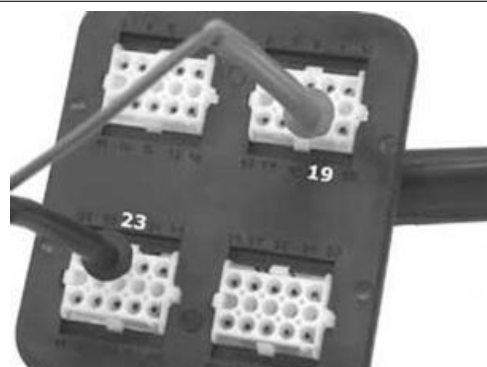

**16** - Replace the control unit.

**17** - Check the presence of voltage (+ batt.) between pin 86 of the pump remote control switch and pin 23 of the control unit. Fix the wiring, if required. Check the relay coil continuity.

85 - 86 =  $100 \pm 50\Omega$

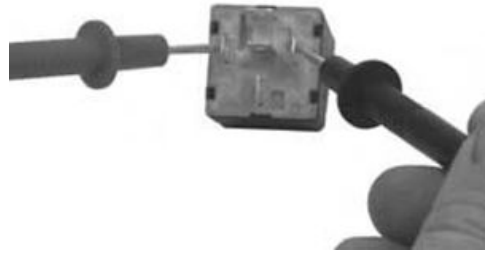

**18** - Check the efficiency of the 10 A fuse no. 2

YES go to 20 NO go to 19

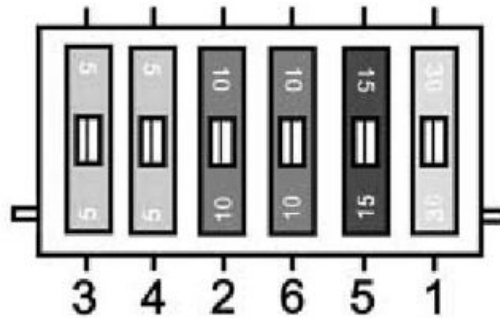

**19** - Disconnect the following connectors: fuel pump, H.V. coil, injector

YES go to 22

**20** - Check the efficiency of the pump remote control switch. Check the wiring continuity between remote control switch and pump.

87 (remote control switch) - green/black (pump) = continuity

NO go to 21

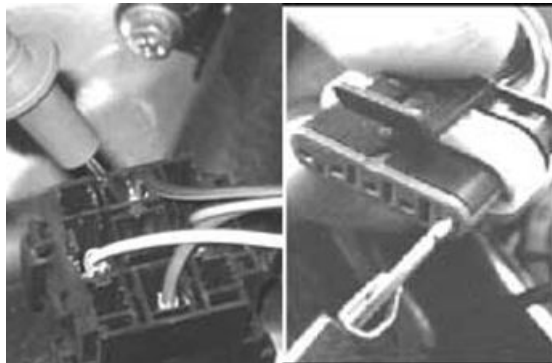

**21** - Fix the wiring and repeat the check from the beginning.

**22** - Check the earth insulation of wiring

87 (pump remote control switch) - 23 = insulation (>1 M $\Omega$ )

YES go to 24 NO go to 23

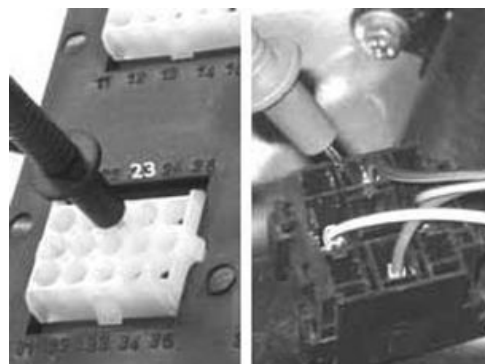

**23** - Restore the wiring insulation and replace the fuse.

**24** - Check the ground insulation of the primary winding of the HV coil and of the injector coil.

YES, go to 25

**25** - Check the pump winding resistance: approx. 1.5Ω

YES go to 26 NO go to 27

**26** - Replace the fuse and check the pump.

**27** - Check the absorbed current.

**28** - Select the diagnostic tester menu on the "**ACTIVE DIAGNOSIS**" function. Select the fuel pump simulation function. Enable the function with continuous power supply on and engine off.

YES go to 29

### Specific tooling

#### 020460Y Scooter diagnosis and tester

**29** - The tester prompts the control unit to start the pump for 30 seconds

YES go to 30

**30** - Acoustically check the following conditions:

- Relay closure
- Pump rotation
- Relay opening

YES go to 31 NO go to 32

**31** - The pump is fed. Perform a functional check of the pump.

**32** - Check the efficiency of the pump connector.

YES go to 33 NO go to 34

**33** - Replace the fuel pump.

**34** - Restore

The injection CPU manages the negative of the light. The light must go off after the initial check. The light goes on again when the CPU autodiagnosis detects a fault. When the fault disappears the light goes back off, however, the related operating tests need to be carried out. The light can go on whether the engine is able to run or not.



## Circuit leak test

Before performing the checks concerning the system pressure, it is necessary to carefully clean all feeding system components.

To perform the inspections it is necessary to use the special tooling kit for fuel pressure check.

### Specific tooling

#### 020480Y Petrol pressure check set

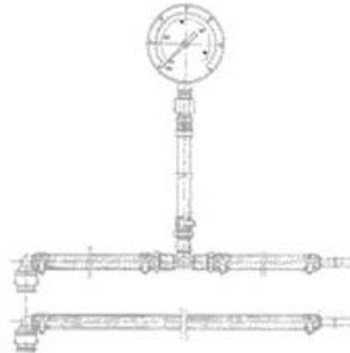

Before disconnecting any fastener, reduce the system pressure.

Detach the electrical connector from the pump support with the engine running, and wait for the shut-down.

The engine stops at approximately 1.5 bar.

#### CAUTION

**CAREFULLY DETACH THE HOSE TERMINAL PREVENT ANY POSSIBLE SPRAYING INTO THE EYES.**

The special tool is equipped with fast-release fittings, similar to those provided for the circuit.

In order to disconnect the female terminals (injector side), it is necessary to press the two extensions and draw them.

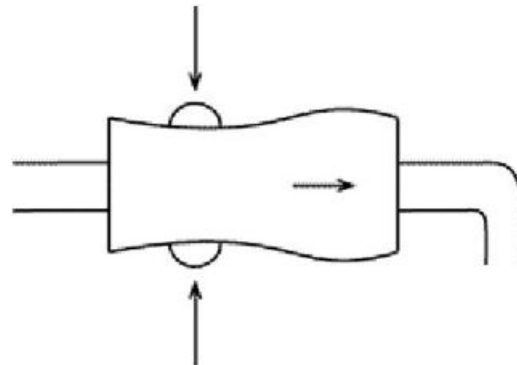

#### CAUTION

**DO NOT FORCE THE TERMINAL IF THIS DOES NOT COME LOOSE; EVENTUALLY, TRY TWISTING IT. THE TERMINAL IS DESIGNED SO THAT AN INCREASE IN TENSION INCREASES THE LOCKING FORCE.**

To detach male type terminals (pump side) it is necessary to press the coaxial rings towards the pump, and extract the terminals.

#### CAUTION

**DO NOT FORCE THE TERMINAL IF THIS DOES NOT COME LOOSE; EVENTUALLY, TRY TWISTING IT. THE TERMINAL IS DESIGNED SO THAT AN INCREASE IN TENSION INCREASES THE LOCKING FORCE.**





The system pressure check must be carried out, for practical reasons, by connecting on the pump side.

Connect the manometer to the outlet duct (RHS) and the extension tube to the inlet duct (LHS).

**CAUTION**  
BEFORE REASSEMBLING CHECK THE TOOL DUCTS ARE CLEAN.

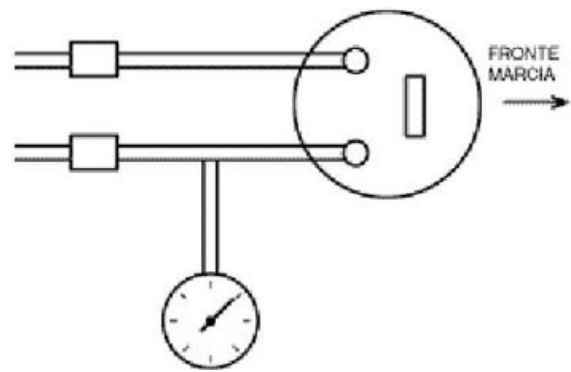

### Pressure regulator check

1 - Connect the diagnostic tester.

#### Specific tooling

**020460Y Scooter diagnosis and tester**



Select the menu on the "ACTIVE DIAGNOSIS" function.

Select the "PUMP DIAGNOSIS" function.

YES go to 2

2 - Enable the function with continuous power supply on and engine off.

The control unit starts the pump for 30 seconds

YES go to 3

3 - Let the system bleed for a few seconds.

Make sure that there are no external leaks.

Check the regulation pressure with pump power supply voltage higher than 12 V.

Regulation pressure = 300 - 320 kPa (3 - 3.2 BAR)

YES go to 4 NO go to 5



4 - The pressure regulator is efficient.

5 - Pressure too high

Check that the return duct is not clogged or squashed

YES go to 6 NO go to 7

6 - Replace the pressure regulator.

7 - Pressure regulation too low

Start the pump rotation again. Using pliers with flat and long tips, temporarily clamp the return duct by the extension of the specific tool (**the serial pipe does not allow this operation**).

fuel pressure = over 300 kPa (3 BAR)

YES go to 8 NO go to 9

8 - Replace the pressure regulator.

9 - Replace the fuel pump.



## Fuel pump and filter check

This procedure is useful during maintenance to check the filter efficiency in delivery.

Connect the diagnostic tester.

Connect the fuel pressure check kit.

### Specific tooling

020460Y Scooter diagnosis and tester

020480Y Petrol pressure check set

1 - Select the diagnostic tester menu on the «**ACTIVE DIAGNOSIS**» function.

Select the «**PUMP DIAGNOSIS**» function.

The pump starts for 30 seconds.

YES go to 2



**2** - Let bleed for a few seconds.

Make sure that there are no leaks.

Using pliers with flat and long tips, temporarily clamp the return duct by the extension of the special tool with pump power supply voltage higher than 12 V, check the system maximum pressure.

Maximum pressure = > 600 kPa (6 BAR)

YES go to 3 NO go to 4



**Specific tooling**

**020480Y Petrol pressure check set**

**3** - Check the system seal.

Start the pump for 30 seconds using the diagnostic tester.

When the pump stops, wait 3 minutes.

Check the system pressure.

Fuel pressure = over 200 kPa (2 BAR)

YES go to 5 NO go to 6

**Specific tooling**

**020460Y Scooter diagnosis and tester**

**4** - If pressure is lower, carefully check the voltage with pump under stress.

If voltage is higher than 12 V, replace the pump.

**5** - The system seal is efficient.

Check the free flow rate.

AHEAD go to 16

**6** - Repeat the test. When the pump stops, use pliers with flat and long tips to temporarily clamp the return duct by the extension of the special tool.

This causes an increase of the fuel pressure.

AHEAD go to 7



**7** - Check whether the pressure decreases with the same trend as the system when free from bottle-necks

AHEAD go to 8

**8** - Pressure decreases much more slowly

YES go to 9 NO go to 10

**9** - Replace the pressure regulator. Check the system seal again.



**10** - There occur trend variations

YES go to 11 NO go to 13

**11** - Repeat the test clamping the pipe of the special tool in the portion between the branch and the injector.

Check whether the pressure decreases with the same trend as the system when free. Pressure decreases much more slowly

YES go to 12 NO go to 13

### Specific tooling

#### 020480Y Petrol pressure check set

**12** - Check and replace the injector, if required, due to an insufficient seal.

(see "THERMAL GROUP AND TIMING SYSTEM")

**13** - There are no trend variations

Repeat the test clamping the pipe of the special tool in the portion between the branch and the pump. Check whether pressure decreases much more slowly.

YES go to 14 NO go to 15

### Specific tooling

#### 020480Y Petrol pressure check set

**14** - The pump unidirectional valve is faulty. Replace the pump. (see Pump bracket overhaul)

**15** - Check the pipe and the injector union seals more carefully.

Check the component seals again, if necessary.

#### A POOR SYSTEM SEAL ONLY AFFECTS THE START-UP VELOCITY.

**16** - Disconnect the pump connector, start the engine, wait until it stops and connect the connector again.

Disconnect the fuel return pipe from the pump support (left pipe).

AHEAD go to 17



**17** - Introduce the return pipe into a graduated container.

Using the diagnostic tester, start the fuel pump for 10 seconds.

Make sure that the power supply voltage is more than 12V.

Measure the amount of fuel delivered.

Pump free flow rate = 300 - 320 cc.

YES go to 18 NO go to 19



**Specific tooling**

**020460Y Scooter diagnosis and tester**

**18** - The fuel filter is not clogged.

The scooter can be used respecting the limit of 48000 km.

**19** - The flow rate is less than 250 cc.

The fuel filter is dirty. Replace the pump support.

**Pump electrics check**

This section describes the operations to be carried out to perform electric checks on the pump.

**Resistor check**

Disconnect the connector from the pump support.  
Using a tester, measure the pump winding resistance.

Connect the tester probes to the pump support pins as shown in the figure.

**Electric characteristic**

**Resistance:**

approx. 1.5  $\Omega$

In case of infinite resistance, replace the pump.

With infinite resistance, the pump does not rotate.

With resistance close to 0  $\Omega$ , the pump power consumption is too high, with the possibility of blowing the 10 A fuse No. 2. Perform the following check.

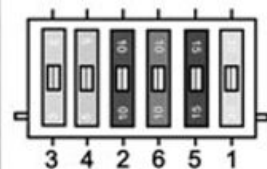

---

## Pump consumption check

The pump power consumption may vary according to:

- Power supply voltage
- Pump running-in
- Regulation pressure
- Delivery filter cleaning

To check the current consumption, proceed as follows

- Disconnect the pump remote control switch connector.
- With key switch set to "**OFF**", connect the jumpers 30-87 on the connector using the tester probes in ammeter function (see figure).
- Check the pump rotation and power consumption



**N.B.**

**THIS CONSUMPTION REFERS TO:**

- **POWER SUPPLY VOLTAGE = approx. 12 V**
- **PUMP RUN IN**
- **SYSTEM PRESSURE = 300 kPa (3 BAR)**
- **FUEL FILTER CLEAN**

### Electric characteristic

#### Current consumption:

approx. 3.5 - 4.2 A

A dirty filter causes an increase of input. If the pressure-relief valve opens, the pump absorbs approx. 6-7A.

In case of excessive input (5A), replace the filter. See pump support overhaul.

If the fault continues, replace the pump.

---

## Fuel filter check

To check the fuel filter inspect the following:

- Free flow
- Current consumed by the pump. A clogged filter causes:
  - Poor performance especially at full power
  - Pump input increase

**N.B.**

**DO NOT BLOW THE FILTER WITH COMPRESSED AIR. A DAMAGED FILTER MAY CAUSE THE INJECTOR CLOGGING.**

---

## Pump bracket overhaul

To remove the pump support from the tank, proceed as follows:

- Disconnect the electric connector.
- Start the engine and wait for the spontaneous stop.
- Clean the tank and the pump support (wash and blow with compressed air, if necessary).
- Disconnect the delivery and return pipes by the fast-release fittings.



**CAUTION**  
**PREVENT ANY FUEL SPRAYING.**

- Loosen the pump support mounting ring nut (RH threading).



- Remove the pump support and the sealing gasket.

**N.B.**  
**UPON EXTRACTING IT, BE CAREFUL NOT TO DEFORM THE FLOATING ARM.**



To replace the components, proceed as follows:

(1) Level indicator:

- Note the assembly position and the path of the two connecting wires.

pos 2 = wire connected to the circuit

pos 3 = wire connected to the movable arm

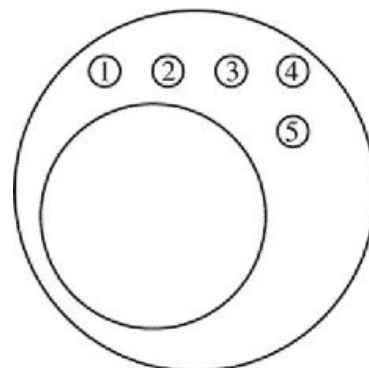

Pass the wires through the hole found between filter and pressure regulator.

- Disconnect and extract the wires
- Using a screwdriver on the retain tab as shown in the figure, extract the level indicator from the support



- Level indicator check

The check may also be carried out before removing it from the support.

Measure the resistance between the two level indicator wires.

Moving the float arm, check that the resistance is subject to gradual variations according to the arm motion.

### **LIMIT VALUES**

	<b>Specification</b>	<b>Desc./Quantity</b>
1	Empty tank position:	95 - 105 $\Omega$
2	Full tank position:	0 - 9 $\Omega$

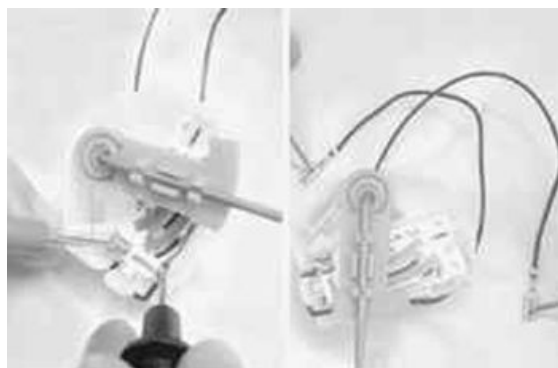

- To refit, repeat the removal operations but in reverse order.

(2) Pressure regulator:

- Remove the locking spring
- Extract the pressure regulator with sealing rings.

**N.B.**

**TO OVERCOME THE RESISTANCE OF THE O-RINGS, LEVER WITH A SCREWDRIVER THROUGH THE OPENINGS OBTAINED ON THE STOP INSERTION SIDE.**



- 
- Lubricate the O-rings and repeat the operations in the reverse order for reassembly.



### (3) Fuel pump

- Note the position of the power supply wires on the support

pos 1 = positive (red)

pos 4 = negative (black)

- 
- Disconnect the power supply cables

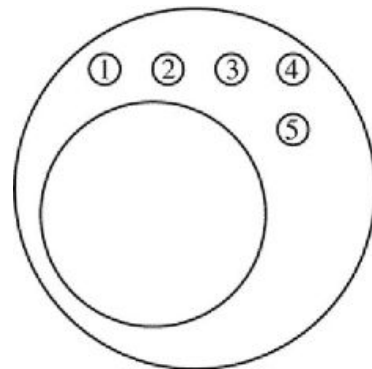

- 
- Cut the delivery pipe fastening clamp on the support.



- 
- Remove the pump mounting washer



- Remove the filter coupling pipe
- Remove the pump with annular support and pre-filter.

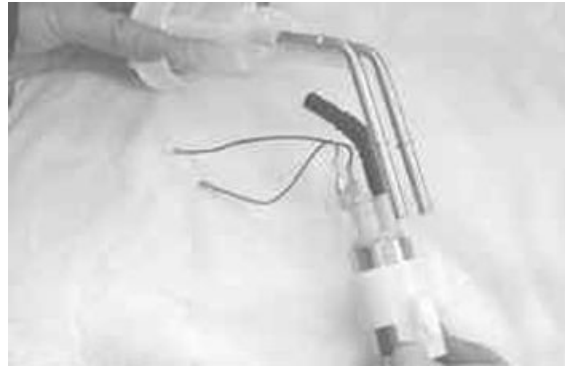

- If the pump requires replacement, remove the pre-filter and the annular support.
- For reassembly, perform the removal operations but in the reverse order using a new clamp for the delivery pipe and a new pump mounting washer.



**N.B.**

**TO CLEAN THE PRE-FILTER, USE PETROL AND COMPRESSED AIR.**

Orientate the pump properly.



#### (4) Fuel filter

The fuel filter is supplied already assembled to the pump support.

To replace the support, move the level indicator, the pressure regulator and the pump from the old to the new support.

For these operations, follows the instructions given above.



## Pump bracket installation

- Before reassembling, carefully check that the tank is clean.

In case of dirt or water, remove the tank.

- Install the sealing gasket on the pump support.
- Introduce the pump into the tank being careful not to deform the level indicator arm.



- Place the sealing gasket on the tank.
- Install the pump support onto the seat aligning the connector with the scooter longitudinal axle.

### N.B.

**AN INCORRECT ORIENTATION MAY IMPAIR THE LEVEL INDICATOR PERFORMANCE.**



- Screw the mounting ring nut and tighten thoroughly.

### Locking torques (N\*m)

#### Electric pump locking ring nut 20

- Connect the feeding circuit pipes again and check the proper introduction by pulling and turning upwards.
- Reconnect the electric connector.
- Recharge the system with at least 4÷5 timings (key switch «OFF-ON»)

### N.B.

**DO NOT START THE PUMP BEFORE REFILLING THE TANK. FAILURE TO OBSERVE THIS RULE CAN DAMAGE THE PUMP.**

- Check that the fuel feeding system fast-release fitting seal is efficient.

## Inspecting the injector circuit

### Electric characteristic

**TERMINAL:** 13 - 23

**CONDITIONS:** During the pump timing with engine off

**STANDARD:** Battery voltage

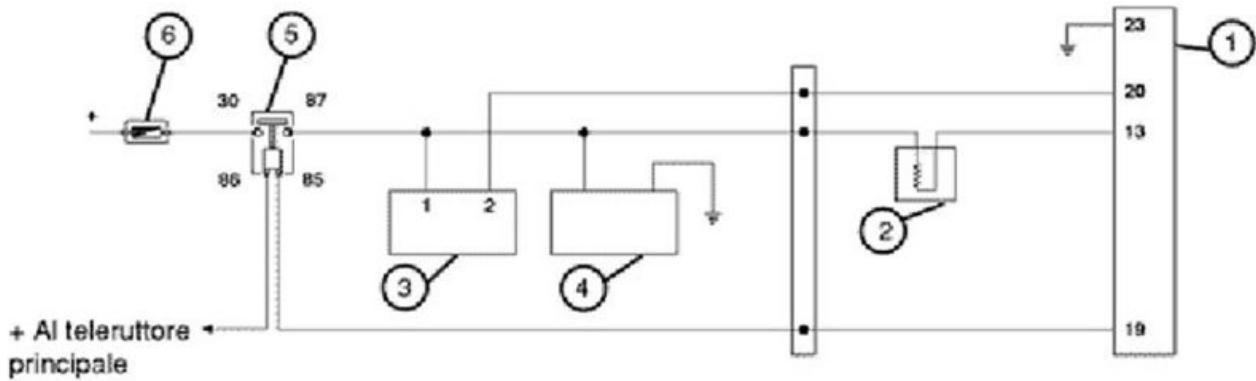

**CIRCUIT LAYOUT**

	Specification	Desc./Quantity
1	Electronic control unit	
2	Injector	
3	HV coil	
4	Pump	
5	Control unit remote control switch	
6	Fuse	10 A

1 - Connect the diagnostic tester. Select the menu on the "ACTIVE DIAGNOSIS" function. Select the "INJECTOR" function. YES go to 2

**Specific tooling**

**020460Y Scooter diagnosis and tester**



2 - Enable the function with continuous power supply on and engine off. The control unit controls the fuel pump continuously and at the same time starts the injector opening. The injector openings are repeated for a few seconds.

YES go to 3

3 - Acoustically check the injector openings and wait for the tester results

YES go to 4 NO go to 5

4 - 5 injector openings detected. The injection tester displays «test successful».

YES go to 7



**5** - No injector openings detected. The injection tester displays «test failed».

YES go to 9 NO go to 6

**6** - No injector openings detected. The injection tester displays «test successful».

YES go to 8

**7** - The injector control circuit is efficient. Perform the injector hydraulic check.

**8** - The injector control circuit is efficient. Repeat the acoustic check and perform the injector hydraulic check for safety reasons.

**9** - Select the menu on the "ERRORS" function. Check whether the injector failure message only is displayed.

YES go to 14 NO go to 10

**10** - There are also fault messages for: pump relay

YES go to 13 NO go to 11



**11** - There is also a fault message for the HV coil.

YES point 12

**12** - Check the power supply circuit with the 10A fuse and the remote control switch. Common feeding to the fuel pump.

**13** - Check the pump relay control circuit

**14** - Install the special tool between the injection system and the control unit.

YES go to 15

### **Specific tooling**

#### **020481Y Control unit interface wiring**

**15** - Arrange a multimeter with positive prod on pin 13 and negative prod on pin 23. Set the switch to "ON" with switch to "RUN" and side stand raised. Check the presence of battery voltage during the fuel pump timing.

13 - 23 = battery voltage for 2 seconds.

YES go to 16 NO go to 17

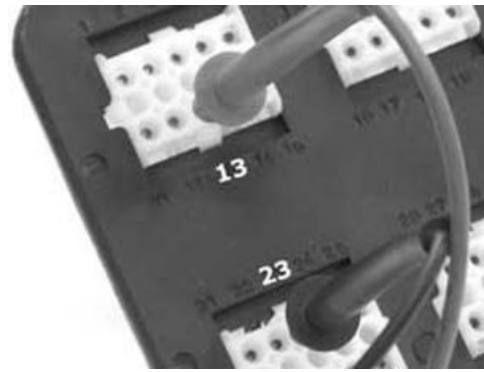

**16** - The injector electric circuit is steady Repeat the checks. If the fault continues, check the control unit connector. If necessary, replace the electronic control unit.

**17** - Repeat the test using the resistance multimeter. Check the resistance between pin 13 and pin 87 (black/green cable) of the pump remote control switch.

13 - black/green =  $14.5\Omega \pm 5\%$  (resistance of the injector)

YES go to 19 NO go to 18

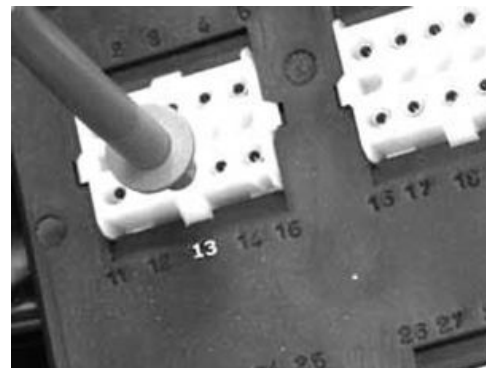

**18** - No continuity. Disconnect the connector and repeat the resistive check directly at the injector terminals.

Resistance =  $14.5\Omega \pm 2\%$

YES go to 21 NO go to 22



**19** - Check the earth insulation of the injector negative line. Disconnected control unit and injector connectors.

13 - 23 =  $\Omega$  infinity

NO go to 20

**20** - Repair or replace the cable harness.

**21** - Check the continuity between the injector power supply connector (red - yellow) and pin 13. Restore the continuity, if required, or replace the wiring

**22** - Replace the injector.

## Inspecting the injector hydraulics

To check the injector it is advisable to remove the intake manifold along with throttle body and injector.

The injector should be removed from the manifold only if necessary.

For these operations, see the "thermal group and timing system" chapter

**1** - Connect the diagnostic tester. Use the socket in the under-saddle compartment.

Install the fuel pressure check kit special tool.

In this case, the injector can be connected directly to the tool quick couplings.

AHEAD go to 2

### Specific tooling

**020460Y Scooter diagnosis and tester**

**020480Y Petrol pressure check set**

**2** - Prepare a graduated container with minimum capacity of 100 cm<sup>3</sup> and a resolution of 10-20 cm<sup>3</sup>. Connect the injector to the wire supplied with the injection tester. The wire is provided with alligator clips for direct connection to the battery.

Prepare an auxiliary battery.

Set the switch to "**ON**" with switch to "**RUN**" and stand raised.

Select the "active diagnosis" function.

Start the pump diagnosis.

During the first 30 seconds of pump diagnosis, power the injector by the wire and the auxiliary battery for 15 seconds.

Collect the fuel delivered by the injector into the graduated container.

Power supply pressure = 300 kPa (3 BAR)

Quantity delivered = approx. 40 cm<sup>3</sup>

YES go to 3 NO go to 4



**3 - Perform the injector sealing test.**

Dry the injector outlet with a blast of compressed air. Activate the fuel pump. Wait for one minute, making sure there are no leaks coming from the injector. Slight oozing is normal.

Value limit = 1 drop per minute

YES go to 5 NO go to 6

**4 - Higher quantities are not expected.**

For lower quantities, replace the injector (THERMAL GROUP AND TIMING SYSTEM).

**5 - The injector is conforming.**

**6 - Repeat the test. If the fault continues, replace the injector (THERMAL GROUP AND TIMING SYSTEM)**

The injector atomisation cannot be checked by simple methods. The injector is provided with 5 holes whose angulation forms a jet with a taper of about 80°. The jet thus formed impinges both intake valves.

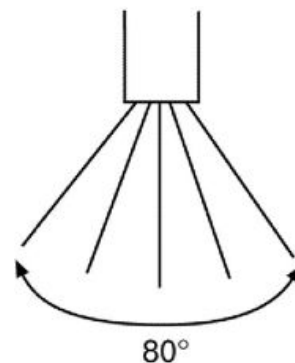
**N.B.**

- AN INJECTOR WITH LOW FLOW RATE AFFECTS THE MAXIMUM PERFORMANCE.
- AN INJECTOR WITH POOR SEAL AFFECTS IDLING AND THE START-UP FEATURES AFTER A SHORT STOP WITH HOT ENGINE.
- IN CASE OF CLOGGING OF THE INJECTOR, IT IS NECESSARY TO REPLACE IT, ALONG WITH THE FUEL FILTER CONTAINED IN THE TANK. CAREFULLY CLEAN THE SYSTEM AND THE TANK.

**Immobiliser circuit**

The EMS system is integrated with the immobiliser anti-theft device.

Its functions are:

- Start-up enabled by key recognition.
- Deterrent flashing.





### System components

The system consists of:

- EMS system control unit
- Decoder
- Aerial
- Master key (red)
- Service key (black)
- Deterrent and diagnosis LED

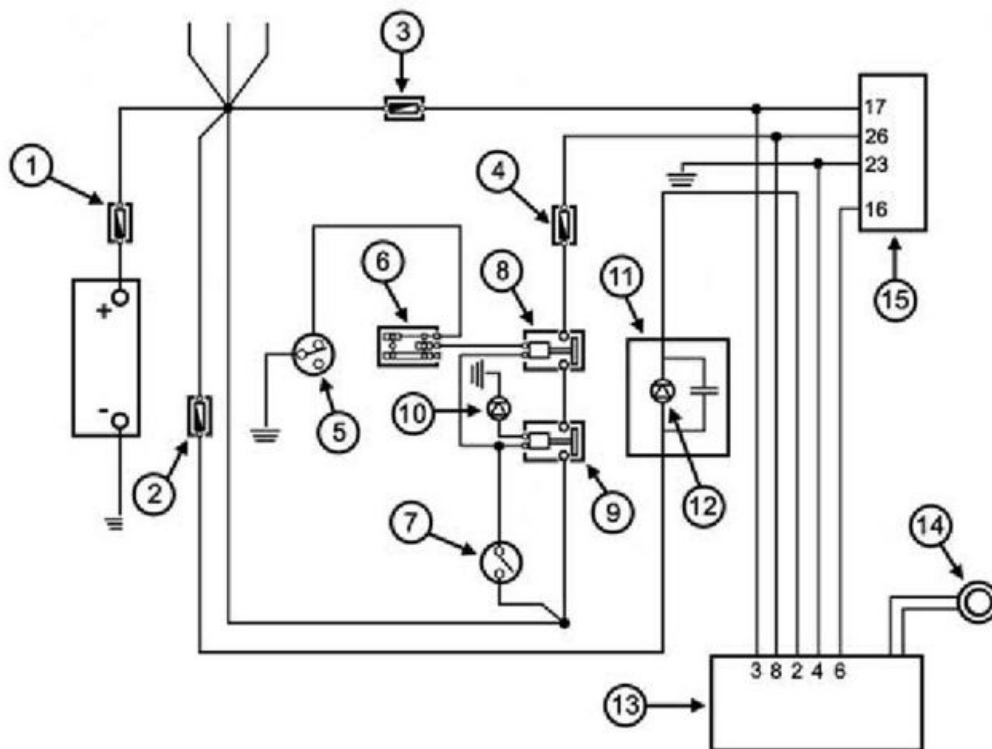

### SYSTEM COMPONENTS

	Specification	Desc./Quantity
1	Main fuse	30 A
2	Fuse	7.5 A
3	Fuse 5A	
4	Fuse	5A
5	Stand switch	
6	Emergency switch	
7	Key switch	
8	Engine stop remote control switch	
9	Main remote control switch	
10	Diode 1A	
11	Instrument panel	
12	Immobilizer LED	
13	Decoder	
14	Immobilizer aerial	
15	Electronic control unit ECU	

## Virgin circuit

When control unit (ECU) and decoder are not programmed, the following conditions occur:

- Key switch set to "OFF". Deterrent flashing inactive.
- Key switch set to "ON". Ignition and injection disabled and LED on with solid light.

When the key switch is set to "ON", the LED switches on as shown in the figure.

The LED is turned on by the decoder.

The control unit data can be checked by the diagnostic tester.

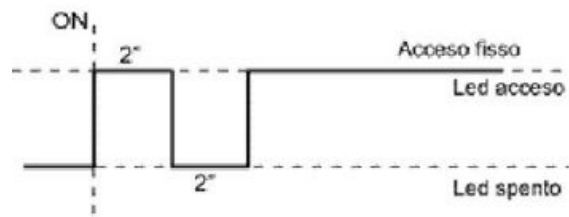

## Specific tooling

### 020460Y Scooter diagnosis and tester

To connect the diagnostic tester, open the spark plug inspection port and pull out the EMS Diagnosis socket. Remove the protection cap and connect the tester terminal.

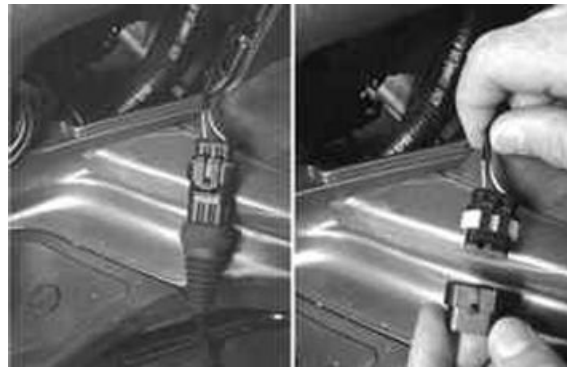

Power the diagnostic tester by connecting the terminals to the battery poles, or the specific connector to the socket inside the gloves compartment.



Set the switch to "**ON**" and select the diagnostic tester menu to the immobiliser function.  
Scroll the pages to display the control unit data.

**N.B.**

**AN UNPROGRAMMED SYSTEM CANNOT BE DETECTED UPON FIRST FITTING, OR IN CASE THE DECODER AND THE CONTROL UNIT ARE REPLACED CONCURRENTLY.**

The information will be as follows:

Unprogrammed control unit «**ON**»

Start-up disabled «**ON**»

Key number Zero › 250

## Setting the circuit

The scooter is supplied with two keys:

- Master key (red) with removable transponder
- Service key (black) with fixed transponder

The master and service keys must be used to code the system as follows:

- Insert the master key, set to «**ON**» and keep this position for 2 seconds (limit values 1÷3 seconds).
- Insert the black key and set to "**ON**" for 2 seconds.
- If you have copies of the key, repeat the operation with each key.
- Insert the master key again and set to "**ON**" for 2 seconds.

The maximum time to change keys is 10 seconds.

Seven service keys (black coloured) can be programmed within the same storage operation.

It is essential to adhere to the times and the procedure. If you do not, start again from the beginning.

Once the system has been programmed, master key transponder, decoder and control unit are strictly matched.

With this link established, it is now possible to encode new service keys, in the event of losses, replacements, etc.

Each new programming deletes the previous one so, in order to add or eliminate keys, you must repeat the procedure using all the keys you intend to keep using.

**N.B.**

**AN ACCIDENTAL LOSS OF THE SERVICE KEY PROGRAMMING CAN ARISE FROM GENERAL FAULTS OF THE IGNITION SYSTEM. IN THIS CASE, CHECK THE HV LINE SHIELDING.**

In any case it is advisable to use resistive spark plugs.

### LED signals

When the key switch is set to "ON" and programming is performed normally, the LED switches on as shown in the figure.

#### WITH MASTER KEY

After the confirmation flash when switching to "ON", a number of flashes are emitted, equal to the number of keys used for programming.

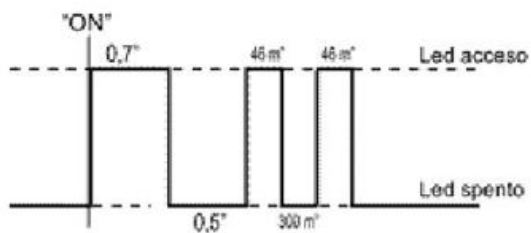

#### WITH SERVICE KEYS

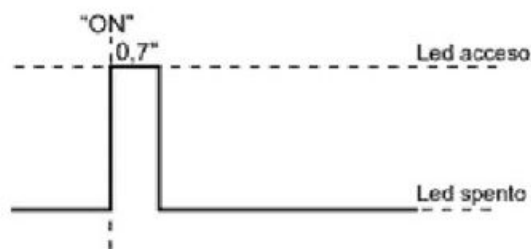

### Deterring blink

Switching from «ON» to «OFF» with programmed system causes the intermittent switching on of the LED, with an antitheft effect.

This occurs with any key used for programming.

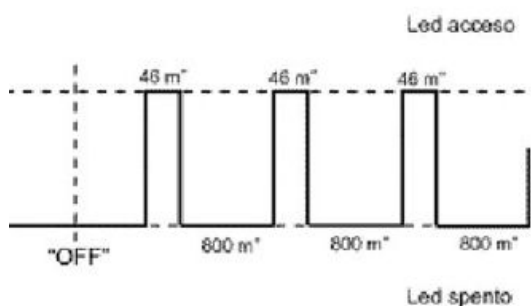

If the scooter is not used, the deterrent light stops automatically after 48 hours to prevent discharging the battery. A new 48-h cycle starts by switching from "OFF" to "ON" and "OFF" again.

## Checking master-box data

Connect the diagnostic tester.

Set to «ON» and select the immobilizer function.

Scroll the pages the find the data.

### Specific tooling

**020460Y Scooter diagnosis and tester**



The information will be as follows:

- Unprogrammed control unit «OFF»
- Start-up disabled «OFF»
- Number of keys 2\*

\*The number denotes how many keys have been used for programming, master key included.

## Resetting the circuit

### 1 Replacing the small cylinder

- Remove the original master key transponder and install it on the master key of the new cylinder.
- Program the system again as described above.

### 2 Decoder replacement

When the decoder is replaced it is necessary to program the system again.

Programming is indispensable for the engine start-up. (see System programming).

### 3 Control unit replacement

Programming is indispensable when the control unit is replaced to enable the engine start-up.

In this case it is sufficient to switch to "ON" using the master key.

**N.B.**

- **THE SERVICE KEY (BLACK-COLOURED) IS NOT USED FOR PROGRAMMING.**
- **WHEN NOT PROGRAMMED, THE CONTROL UNIT ALLOWS NO FUNCTIONAL DIAGNOSIS ON THE ENGINE.**

### 4 Replacing or duplicating service keys

Keys can be duplicated using the blank keys and the original master key.

A copy may also be requested using the scooter CODE CARD.

Program the system again using the master key and all service keys (see System programming).

**N.B.**

**THE CODE CARD CAN ONLY BE USED WHEN THE ORIGINAL MASTER KEY IS AVAILABLE.**

## Diagnostic codes

The LED indication is divided into 3 steps:

1st step: A flash: "**ON**" switching recognition

2nd step: Series of flashes: diagnosis code indication

3rd step: Steady light on or off:

on = start-up disabled off = start-up enabled

## Code 1

Code 1 indicates a non-programmed system.

If the code is still displayed after having carried out the programming procedure, repeat the procedure carefully observing the "**ON**" times of each key.

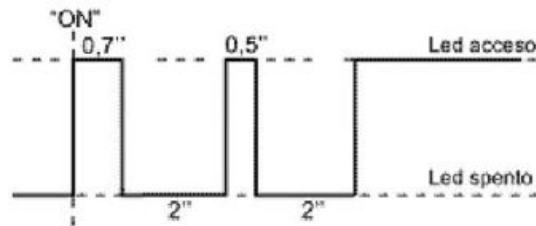

If the code is still displayed, proceed as follows:

- Disconnect the battery negative.
- Remove the control unit connector.
- Connect the special tool between the injection system and the control unit.
- Remove the main decoder connector.

**N.B.**

**TO ACCESS THE COMPONENTS, SEE THE COMPONENTS LAYOUT CHAPTER.**

### Specific tooling

#### 020481Y Control unit interface wiring

1 - Using a multimeter, check the continuity between pin 16 of the control unit and pin 6 of the decoder connector.

YES go to 3 NO go to 2

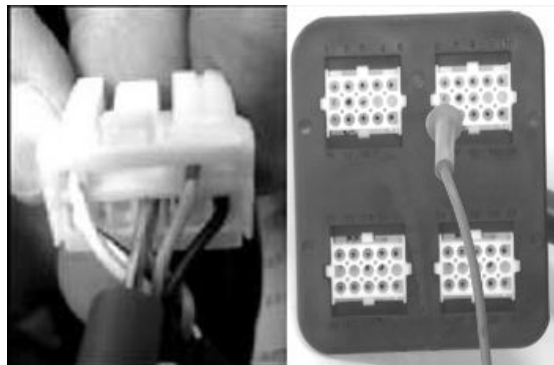

2 - Repair or replace the wiring.

3 - Check the connections carefully

YES go to 5 NO go to 4

4 - Restore

5 - Replace the decoder. Connect the battery. Repeat the programming. YES go to 7 NO go to 6

6 - Disconnect the battery, replace the control unit, connect the battery. Repeat the programming.

7 - The system is OK

**Code 2**

Code no. 2 denotes a system where the decoder does not perceive the transponder signal.

- Start-up disabled
- Injection telltale light on, steady

In this case, proceed as follows:

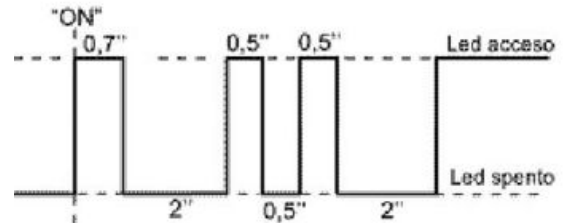

**1** - Check whether the code is repeated using the second key.

YES go to 3 NO go to 2

**2** - Failure detected with the service key Replace and program again. Failure detected with the master key.

Replace the transponder using one from the new cylinder kit.

Replace decoder and control unit.

Program again.

**3** - Check the proper connection of the aerial connector.

YES go to 5 NO go to 4



**4** - Restore the connection and check the presence of the code

**5** - Disconnect the aerial connector and check continuity ( $8 \pm 2 \text{ W}$ ).

YES go to 7 NO go to 6

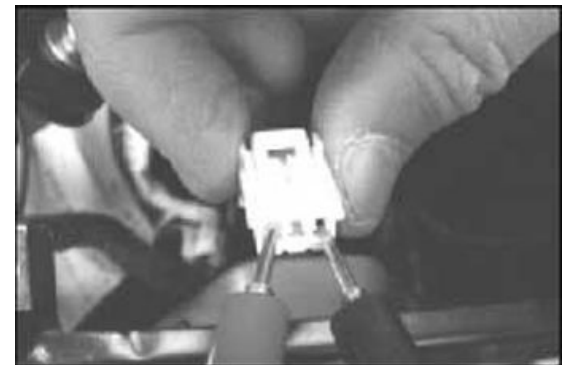

**6** - Replace the aerial.

**7** - Check the proper position of the aerial.

YES go to 9 NO go to 8

**8** - Place it in proper position

**9** - Replace the decoder and check the presence of the code

### Code 3

Code no. 3 denotes a system where the decoder perceives a transponder not provided for by programming.

- Start-up disabled
- Injection telltale light on, steady

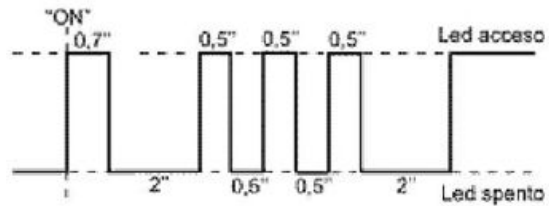

1- Check whether the code is still displayed using the master key

YES go to 3 NO go to 2

2 - Program again using all service keys

3 - Check that all components (keys - decoder - control unit) are properly matched.

YES go to 5 NO go to 4

4 - Restore

5 - Replace decoders and control unit. Program the components again.

### Code 4

Code no. 4 denotes a system where the decoder is blank and the control unit is programmed.

The key is recognised by the control unit.

- Start-up disabled
- Indicator light

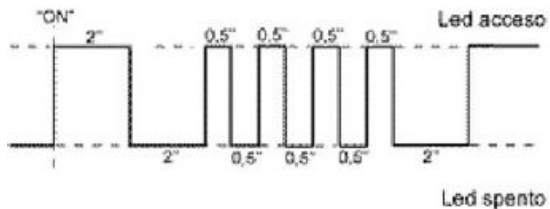

**N.B.**

**REPEAT THE KEY PROGRAMMING PROCEDURE USING THE ORIGINAL MASTER KEY.**

### Diagnosis guide

#### Immobiliser LED does not come on

1 - Check whether the injection indicator turns on for 5 sec. after switching to "ON"

YES go to 2 NO go to 11

2 - Check 7.5A fuse No.10 located on the front glove-box.

YES go to 4 NO go to 3

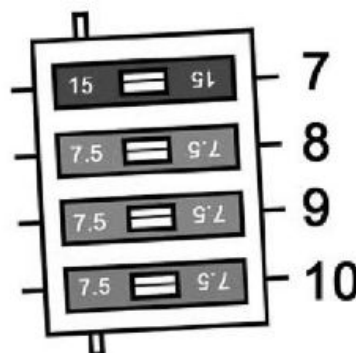



**3** - Check for any short circuits on the instrument unit power supply line, check that the instrument unit has not short-circuited

YES go to 5

**4** - Check whether the LED comes on when pin No. 2 of the decoder connector is connected to ground (yellow/grey cable).

YES go to 6 NO go to 7

**5** - Restore

YES go to 2

**6** - Replace the decoder and reprogram.

**7** - Check for continuity on the yellow/grey cable, measuring between the decoder connector and the 8 pin connector of the instrument panel

YES go to 8 NO go to 10

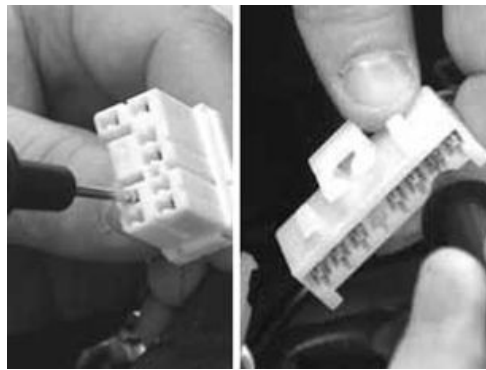

**8** - Check for positive battery voltage on the red/black cable of the 8-way connector of the instrument panel.

YES go to 9 NO go to 10



**9** - Faulty led, replace the instrument panel.

**10** - Repair or replace the wiring.

**11** - If the injection light does not come on, continue with the check of the supply circuit to the decoder and of the central control unit.

---

## Tachometer

### Electric characteristic

**TERMINAL:** 7 - 12

**CONDITIONS :** Start-up speed

**STANDARD:** approx. 0.8 - 4.5 V

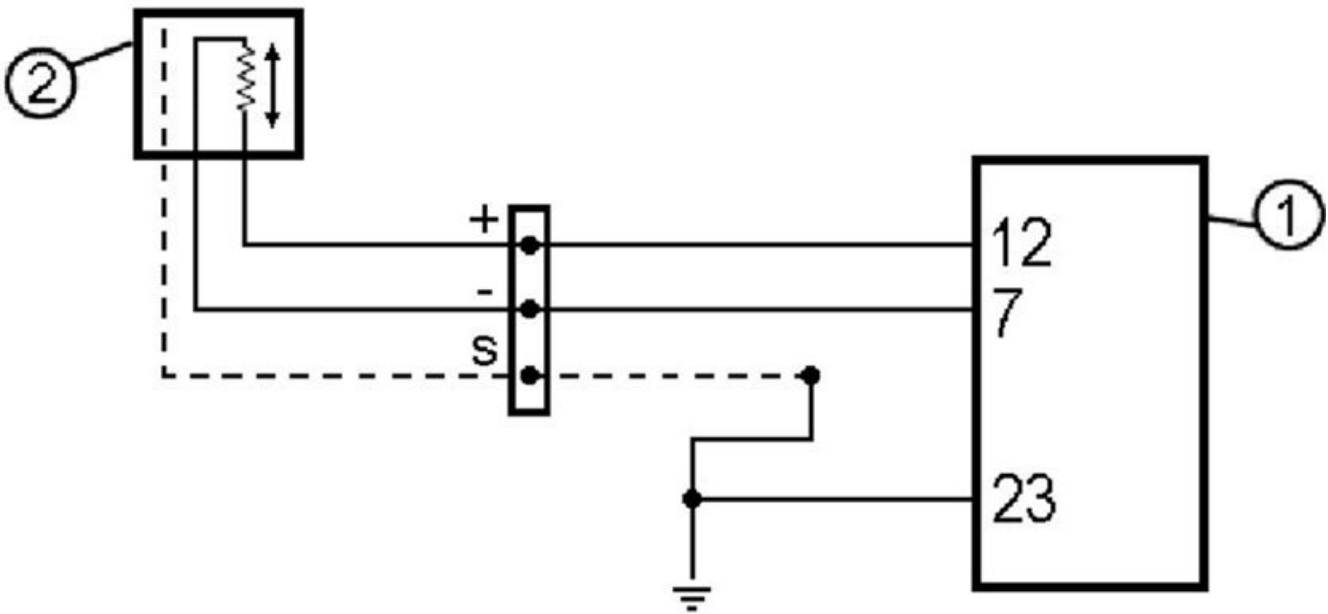

**CIRCUIT LAYOUT**

	Specification	Desc./Quantity
1	Electronic control unit	
2	Engine rpm sensor	

The sensor allows the rotations and the angular position of the crankshaft to be recognised by reference to the TDC. Since the wheel speed sensor is pivoted on the camshaft it is also possible to recognise the 4-stroke cycle. Such solution allows controlling the injector and the spark plug every two revolutions of the crankshaft.

The sensor is of the reluctance variation type and is therefore comparable to an alternate current generator that powers the control unit.

The signal frequency is interrupted by the vacuum generated by the two missing teeth on the wheel speed sensor.

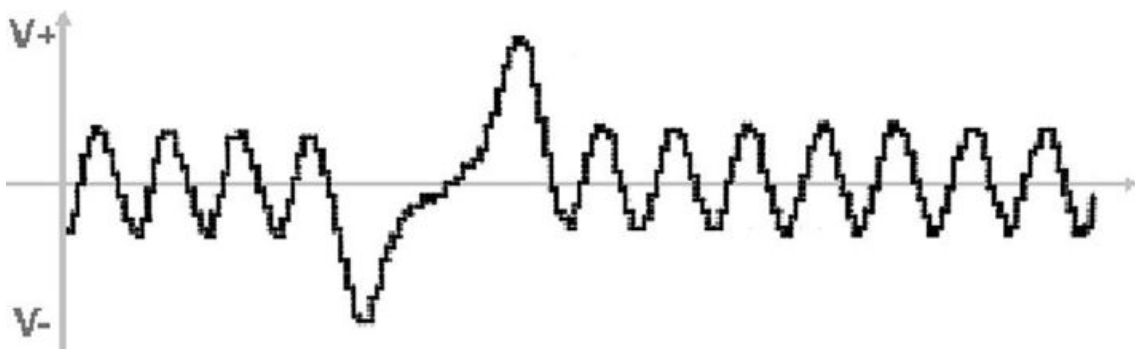

The sensor signal is fundamental for obtaining starting of the engine.

The ECU self-diagnosis is enabled on this circuit in 2 different ways based on use conditions.

Right after turning to «ON» (Power under the panel present in the CPU), the continuity and isolation of the sensor and related circuit are checked.

Any faults discovered in this phase are signalled via the injection telltale light.

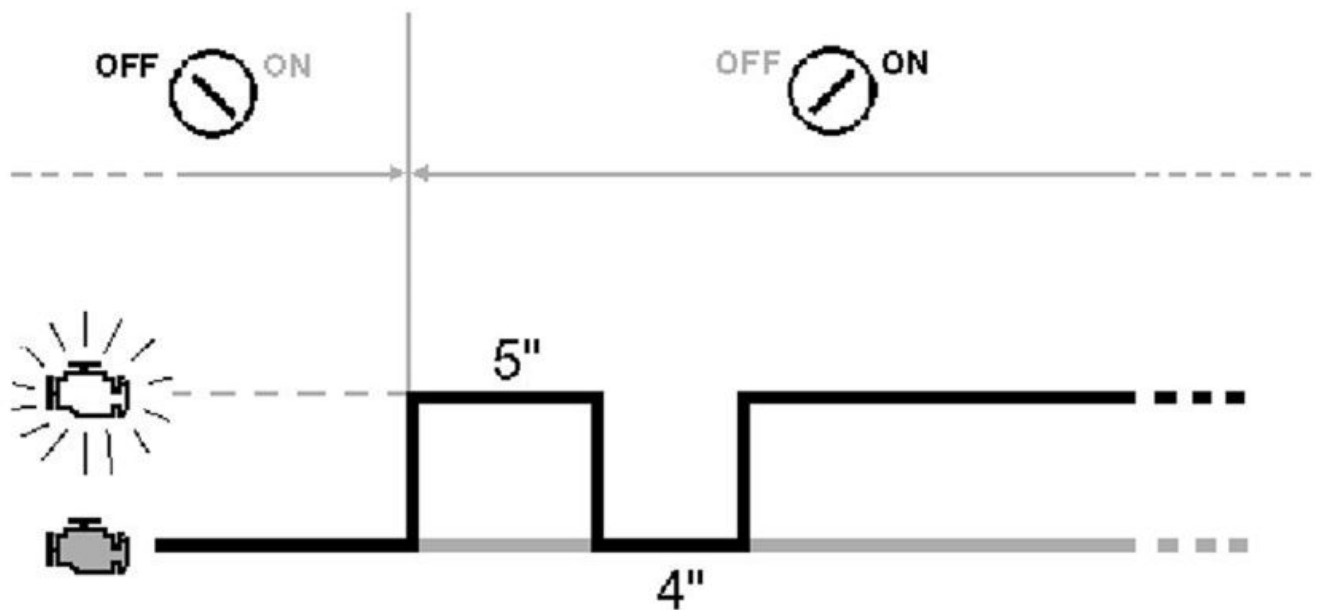

The fault continues to be signalled, but the circuit is only checked when turning to "ON". Therefore faults which occur or disappear after turning to "ON" are not acknowledged.

During and after the start phase, the self-diagnosis checks the alternating current produced by the sensor (synchronisation of the signal panel).

If a signal panel is detected which is not perfectly synchronised, corrective interventions are applied used to reconstruct the cycle. In this case the self-diagnosis records the number of lost synchronisations and signals the fault via the injection telltale light.

The light remains on during the period the cycle is reconstructed.

If the rpm-timing signal is completely missing due to mechanical faults or lack of magnetic activity, it will be impossible to start the engine (or it will stop while driving) and the self-diagnosis will not be able to record any faults.

To check the sensor and related circuit, proceed as follows:

1 - Connect the scooter tester.

Select the function "ERRORS" in the menu.

Check for any faults on the «Signal panel».

YES go to 2 NO go to 3

### Specific tooling

**020460Y Scooter diagnosis and tester**

### 2 THE FAULT HAS BEEN RECORDED IN MEMORISED STATUS:

The signal panel may be synchronised with possibility of starting. The fault is probably occasional.

**N.B.**

**A NON-CONFORMING SIGNAL PANEL FAULT MAY ALSO BE DETECTED IF THE ENGINE STOPS AFTER A FAULT INVOLVING IDLING.**

**THE FAULT HAS BEEN RECORDED IN CURRENT STATUS:**

The control circuit gave a negative result when switching to "ON".

AHEAD go to 8

**3** Select the "PARAMETERS" function on the menu.

Check the number of «lost synchronisations»:

1 TOOTH and > 1 TOOTH

YES go to 4 NO go to 5

**4 THE INDICATION INCREASES PROGRESSIVELY OVER TIME WITH THE ROTATION OF THE ENGINE.**

AHEAD go to 8

**5 INDICATION = 1-3**

**THE RPM-TIMING CIRCUIT IS IN COMPLIANCE.**

Make an attempt to start and use the parameters function to check for the «engine revs» indication.

YES go to 6 NO go to 7

**6** The signal panel is in conformance.

**7 CHECK THE AIR GAP AND MAGNETIC ACTIVITY OF THE SENSOR.**

See engine mechanics.

**8** Check the sensor and related connection circuit with the control unit.

AHEAD go to 9

**9** Install the connection wiring between the control unit and injection system. Do not make the connection with the control unit.

CONTINUE at 10

**Specific tooling**

**020481Y Control unit interface wiring**

**10** Install the connection connector between the rpm timing sensor and injection system.

Measure the sensor resistance by connecting a multimeter between the terminals marked + and - (see the "Electrical system" chapter).



**RESISTANCE OF THE RPM TIMING SENSOR: (AT 25°C)**

	Specification	Desc./Quantity
1	Model with 1 clamp:	860 $\Omega$ $\pm$ 130 $\Omega$
2	Model with 2 clamps:	680 $\Omega$ $\pm$ 100 $\Omega$

YES go to 11 NO go to 12



**11** - Check the earth isolation between a pole and the shielding.  
(see the «Electrical system» chapter).

**Electric characteristic**

**S - + =**

infinite (>M $\Omega$ )

YES go to 13 NO go to 12



**12** - Replace the revolution sensor.

**13** - Reconnect the rpm-timing sensor connector.

Repeat the resistance check through the injection wiring pin 7, pin 12.

**Electric characteristic**

**7-12 =**

680  $\Omega$   $\pm$  100  $\Omega$  (Model with 2 clamps)

**7-12 =**

890  $\Omega$   $\pm$  130  $\Omega$  (Model with 1 clamp)

The value should be very close to that detected directly by the sensor.

YES go to 17 NO go to 14

**14** - Higher or infinite resistance.

YES go to 15 NO go to 16

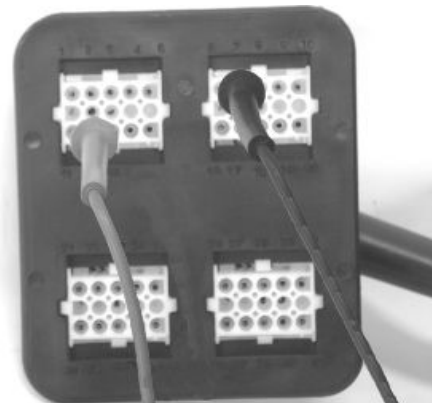

**15** - Check the connectors carefully. Disconnect and check the continuity between connector and pin 7-12

**Electric characteristic**

**Connector - 7 =**

Continuity

**Connector - 12 =**

Continuity

Fix the connectors or replace the cable harness.

**16**

**Electric characteristic**

**Resistance**

0

Repair or replace the injection wiring (short circuit)

**17** - Check the earth insulation again.

**Electric characteristic**

**7-23 =**

infinite (>1MΩ)

YES go to 19 NO go to 18

**18** - Check the sensor and control unit connectors. Repair or replace the injection wiring

**19** - Measure the alternated voltage between pins 7 and 12 with engine at start-up speed.

**Electric characteristic**

**7-12 =**

approx. 0.8 - 4.5 V eff

**Revolution speed =**

approx. 300-400 rpm

YES go to 20 NO go to 21

**20** The sensor circuit is in conformance.

Use the parameter function to check if the engine rpm indication is present when trying to start.

If not, carefully check the ECU connection connector and replace it if necessary.

**21** Check the air gap and magnetic activity of the sensor.

See the "Combustion unit and distribution" chapter.

If there is no magnetic activity replace the sensor.

**N.B.**

**-THE SENSOR CABLE MUST BE PROPERLY INSTALLED FOR SERVICING.**

**-DO NOT FORCE THE CABLE.**

**-A POOR CABLE SHIELDING CAN IMPAIR THE ENGINE PERFORMANCE AT HIGH SPEED.**

---

**HT coil**

This section describes the ignition system operation.

**Circuit diagram**

**Electric characteristic**

**TERMINALS:** 20 - 23

**CONDITIONS :** During the pump timing with engine off.

**STANDARD:** Battery voltage

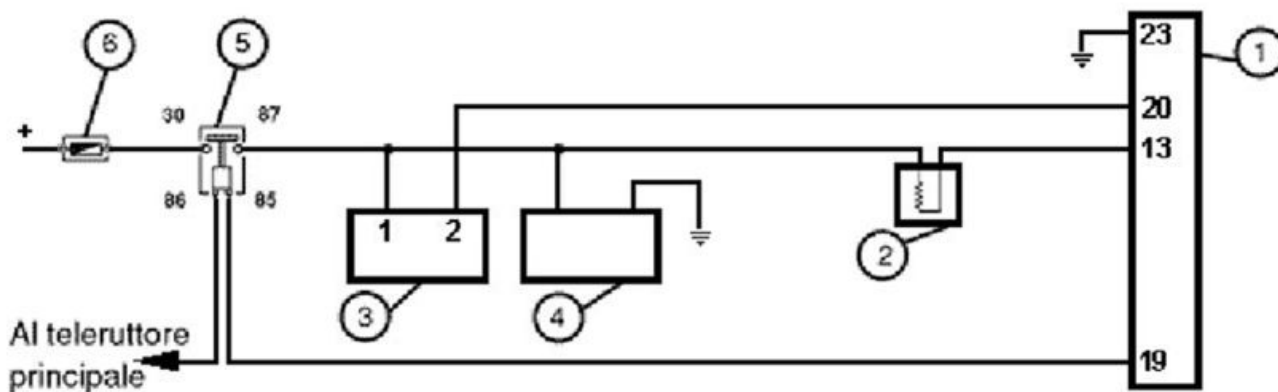

**CIRCUIT LAYOUT**

	Specification	Desc./Quantity
1	Electronic control unit	
2	Injector	
3	HV coil	
4	Pump	
5	Control unit remote control switch	
6	Fuse	10 A

The ignition system is integrated with the injection and it is a high-efficiency inductive type ignition.

The control unit manages two important parameters:

- Ignition advance

This is optimised according to the engine rpm, to the engine load, temperature and ambient pressure

With idle engine, it is optimised to obtain the stabilisation of the speed at  $1450 \pm 50$  R/1'. - Magnetisation time

The coil magnetisation time is controlled by the control unit. The ignition power is increased during the engine start-up.

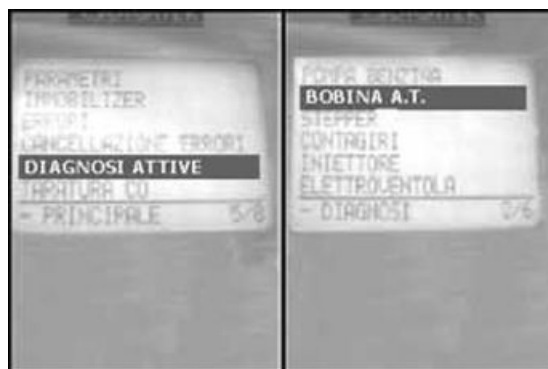

The injection system recognises the 4-stroke cycle and therefore, ignition is only controlled during compression.

To check the ignition circuit, proceed as follows:

**1** - Connect the diagnostic tester. Select the menu on the "ACTIVE DIAGNOSIS" function. Start the HV coil check with switch set to «ON», switch to «RUN» and side stand raised. Wait for the tester to display: "TEST SUCCESSFUL"

YES go to 3 NO go to 2

### **Specific tooling**

#### **020460Y Scooter diagnosis and tester**

**2** - The tester displays: "TEST FAILED". Repeat the test and wait for the tester to display: "TEST SUCCESSFUL"

YES go to 3 NO go to 4

**3** - Select the menu on the "ERRORS" function. Check the presence of current or stored errors relating to the H.V. coil.

YES go to 6 NO go to 5

**4** - Test failed

YES go to 6

**5** - The coil control circuit is efficient.

Check the H.V. coil secondary, the cable and the screened cap

**6** - Install the special tool between the injection system and the control unit.

Measure voltage between pins 20 and 23 of the specific

Specific during the timing phase of the fuel pump.

To start the timing, set the switch to "ON" with switch to "RUN" and side stand raised.

### **Electric characteristic**

**20-23 =**

Battery voltage (coupled to the pump rotation -2 seconds).



If you want to increase the test time, enable the "pump relay diagnosis" function (30 seconds)  
YES go to 7 NO go to 8

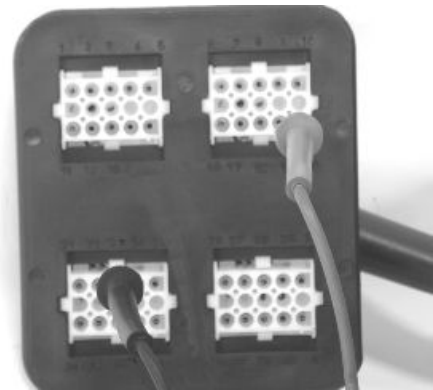

**7** - The coil primary control circuit is efficient.  
 Carefully check the connectors to the control unit and to the coil.  
 Replace the control unit, if necessary.

**8** - Disconnect the connector to the HV coil primary.  
 Repeat the voltage check between the black-green wire and earth.

**Electric characteristic**

**Black-green-23 =**

battery voltage

(coupled to the pump rotation-2 seconds).  
YES go to 10 NO go to 9

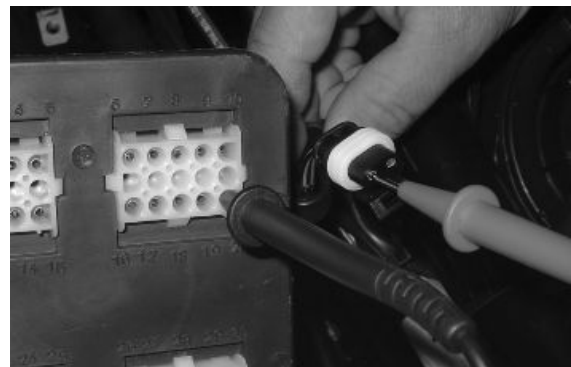

**9** - Check the black-green wire continuity.  
 Repair or replace the cable harness.

**N.B.**

**A FAILURE OF THE REMOTE CONTROL SWITCH WOULD CAUSE THE PUMP ROTATION FAILURE**

**10** - The positive power supply is conforming. Check the continuity between the pink-black wire of the connector and pin 20.

**Electric characteristic**

**Pink-black-20 =**

Continuity

YES go to 12 NO go to 11

**11** - Check the continuity of the pink-black wire in the two systems.

**Electric characteristic**

**Pink-black (coil connector)-20 =**

## Continuity

YES go to 12 NO go to 13

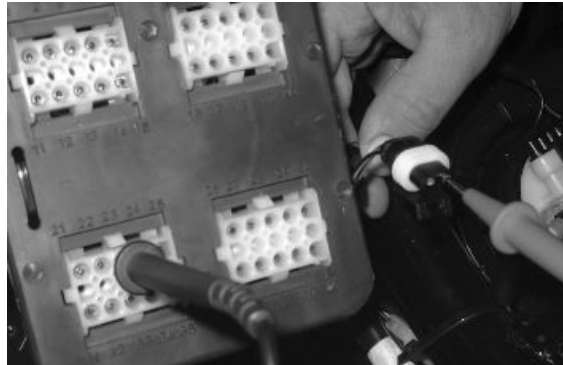

**12** - Check the earth insulation of the negative line.

**Electric characteristic**

**20-23 =**

$\Omega$  infinite ( $>1M\Omega$ )

YES go to 15 NO go to 14

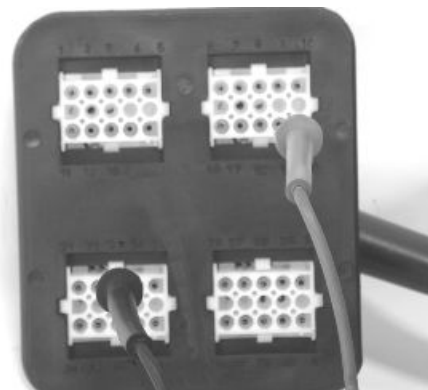

**13** - Repair or replace the faulty system. Repeat the check with the menu on "ACTIVE DIAGNOSIS".

**14** - Repeat the earth insulation check in the two sections. Repair or replace the wiring. Repeat the check with the menu on "ACTIVE DIAGNOSIS" H.V. coil control simulation. Delete the errors stored in memory.

**15** - Check the continuity of the H.V. coil primary. See figure.

**Electric characteristic**

**Primary resistance =**

$0.5 \pm 8\%$

---

YES go to 16 NO go to 19

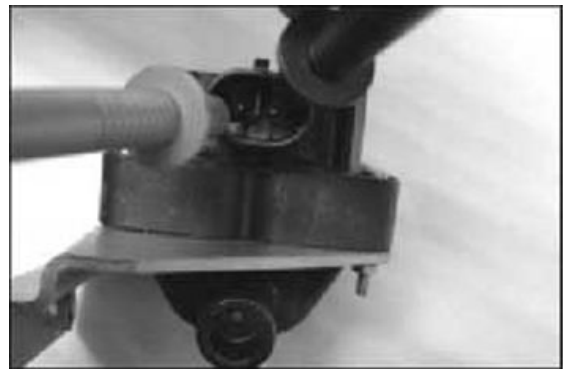

**16** - Check the earth insulation of the primary circuit  
Measure between one of the primary terminals and earth.

**Electric characteristic**

**Primary-earth =**

$\Omega$  infinite ( $>1M\Omega$ )

---

YES go to 17 NO go to 19



**17** - Check the secondary resistance.  
Measure the resistance between one of the primary terminals and the spark plug cable output

**Electric characteristic**

**Primary HV cable output =**

$3.1 K \pm 9\%$

---

YES go to 18 NO go to 19



**18** - The coil is conforming.

**19** - Replace the coil

## Inspecting the spark plug shielded cap

Measure the shielded cap resistance.

### Electric characteristic

#### Resistance:

5 K $\Omega$

If different values are measured (<1; >20K $\Omega$ ), replace the shielded cap.



**N.B.**

**A SHIELDLESS CAP OR SPARK PLUG CAN ADVERSELY AFFECT THE INJECTION SYSTEM. FOR INFORMATION ON THE SPARK PLUG, SEE THE «SPECIFICATIONS» AND «MAINTENANCE» CHAPTERS.**

---

## Spark advance

The ignition advance is determined electronically on the basis of parameters known by the control unit. For this reason it is not possible to declare the reference values based on the engine rpm.

The ignition timing value is detectable any time using the diagnostic tester.

It is possible to check whether the ignition advance determined by the system does in fact correspond with the value actually activated on the engine, by means of the stroboscopic light.

### Specific tooling

**020460Y Scooter diagnosis and tester**

**020330Y Stroboscopic light to check timing**

---

Proceed as follows:

- Remove the transmission compartment cover as described in the "automatic transmission" chapter.



- 
- Remove the TDC reference inspection cap between flywheel and crankcase cover. See the "flywheel cover" chapter



- 
- By the driving pulley, turn the engine to find the alignment of the references to identify the TDC.



- 
- Repeat for the reference between driving pulley and engine crankcase.



- 
- Replace the inspection cap on the flywheel side.
  - Connect the diagnostic tester.
  - Start the engine.
  - Select the «parameter» function in this menu.
  - Select the stroboscopic light command in the traditional four-stroke engine position (1 spark 2 revs).
  - Check that the real values of rpm and ignition advance match those measured using the diagnostic tester.



**If the values do not match, check:**

- distribution timing
- rpm-timing sensor

- Injection control unit

### Coolant temperature sensor

**Electric characteristic**

**TERMINALS:** 4 - 22

**CONDITIONS :** coolant temperature

**STANDARD:**

With connected sensor:

20° = 2500 ± 100 Ω

80° = 308 ± 6 Ω

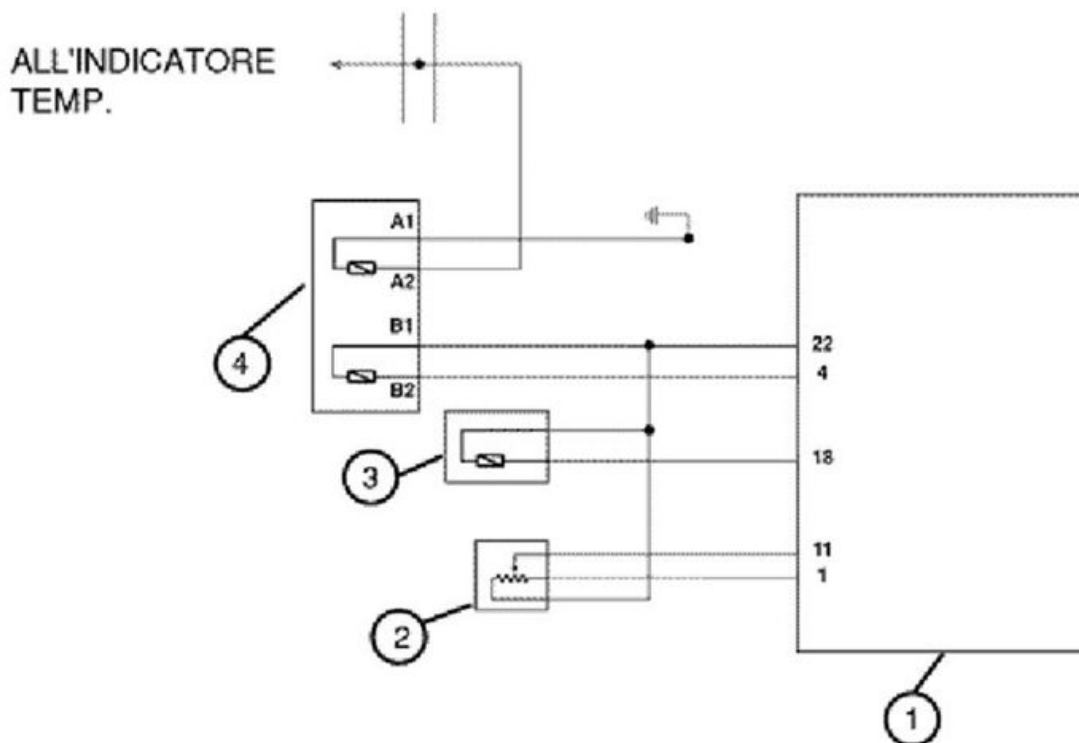

**CIRCUIT LAYOUT**

	Specification	Desc./Quantity
1	Electronic control unit	
2	Valve position sensor	
3	Air temperature sensor	
4	Fluid temperature sensor	

The coolant temperature sensor is installed on the engine head and provides the indications for the digital instrument and for the injection.

It is realised with two electrically different sections.

The injection section is realised with an NTC sensor connected to a 5V powered circuit. The resistance variation causes a variation of the circuit voltage. Such voltage is combined with a temperature value. By this value, the control unit can manage the engine operation, optimising it for all temperatures.

A failure of this circuit causes the switching on of the injection telltale light and the tripping of the safeties (among which the electric fan continuous start). In these conditions, the engine works, even though not in an optimum way, always safeguarding the catalytic converter integrity.

A false temperature value that falls within the range of possible temperatures is a failure very difficult to manage. This can cause a failure of the safeties and an improper management of the ignition. Such failure is more easily detected upon the engine start-up.

To check the sensor and related circuit, proceed as follows:

**1** - Connect the injection diagnostic tester and select the menu on the "errors" function.

Check whether faults have been recorded regarding the coolant temperature sensor.

YES go to 3 NO go to 2

### Specific tooling

#### 020460Y Scooter diagnosis and tester

**2** - The EMS system has received no indications of temperatures out of the range of possible temperatures.

If you suspect a wrong temperature indication, proceed to perform the following check.

**N.B.**

**A WRONG TEMPERATURE SIGNAL CAN BE DETECTED BY COUPLING THE ANALOGUE INSTRUMENT INDICATION WITH THE ELECTRIC FAN START. IN ANY CASE, BEFORE CHECKING THE SENSOR, CHECK THE FILLING AND BLEEDING OF THE COOLING SYSTEM**

**3** - Before checking the sensor and the relevant circuit, wait until the engine has cooled down and the scooter has set to the working area temperature.

YES go to 4

**4** - Set the switch to "ON" with switch to "RUN" and side stand raised. Select the menu on the "parameters" function. Do not start the engine.

YES go to 5

**5** - Check the following values: coolant temperature intake air temperature ambient temperature The three indications are equal or they are slightly different (e.g. 1° C).

YES go to 6 NO go to 7

**6** - The temperature sensor is providing probably correct information.

Check at approx. 80° C.

**7** - Install the special tool.

**WARNING**

**DO NOT CONNECT THE CONTROL UNIT CONNECTOR.**

### Specific tooling

#### 020481Y Control unit interface wiring

YES go to 8

8 - Disconnect the coolant temperature sensor connector. Measure the sensor resistance between the terminals shown in the figure.

Check that the resistance matches the values declared according to the temperature.

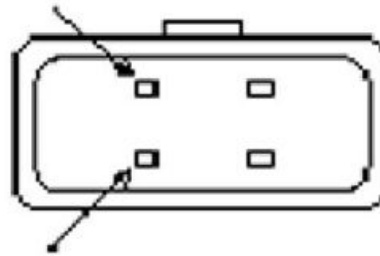

**Electric characteristic**  
**TEMPERATURE RESISTANCE**

9.6 Kohm. -10° C

5.975 Kohm. 0

3.81 Kohm. +10° C.

2.5 Kohm. +20° C

1.68 Kohm. +30° C

0.3 Kohm. +80° C

YES go to 10 NO go to 9

9 - Replace the sensor.

10 - Connect the sensor connector and repeat the resistive check at terminals 4 and 22;

**Electric characteristic**

**4-22 =**

Resistance equal to the value directly detected at the sensor.

YES go to 13 NO go to 11

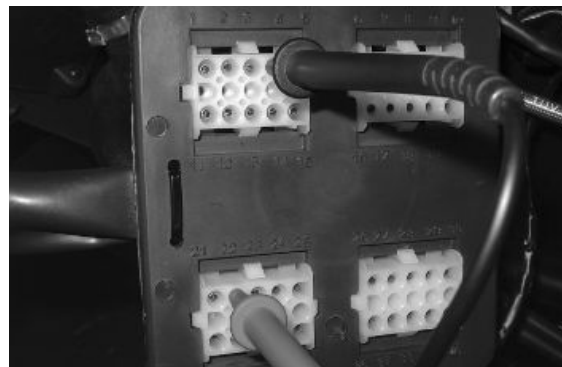

11 - If slightly higher values are detected, check the connectors.

If infinite resistance is detected (>1Mohm) check the continuity between the two lines with disconnected connectors.

**Electric characteristic**

**Yellow/pink - 4 = 0 ohm.**

(Continuity)

**Light blue/green-22 =**

0 ohm. (Continuity)



YES point 12

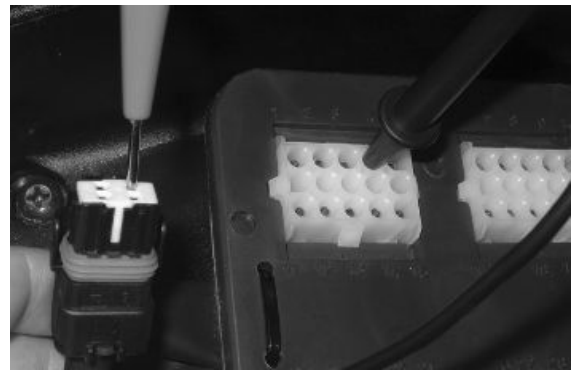

**12** - Repair or replace the cable harness.

YES go to 10

**13** - Check that the sensor circuit is earth insulated.

**Electric characteristic**

**4-23 =**

$\Omega$  infinite (>1M $\Omega$ )

**22-23 =**

$\Omega$  infinite (>1M $\Omega$ )

YES go to 15 NO go to 14

**14** - Repair or replace the wiring.

Check the air temperature lines and the throttle valve position.

YES go to 13

**15** - Connect the special tool to the control unit.

Set the switch to "ON" with switch to "RUN" and side stand raised.

YES go to 16

**Specific tooling**

**020481Y Control unit interface wiring**

**16** - Measure voltage at terminals 4 and 22;

**TEMPERATURE VOLTAGE**

	<b>Specification</b>	<b>Desc./Quantity</b>
1	+ 20° C	2.79 V
2	+ 40° C	1.85 V
3	+ 60° C	1.13 V
4	+ 70° C	0.90 V
5	+ 80° C	0.69 V

YES go to 21 NO go to 17

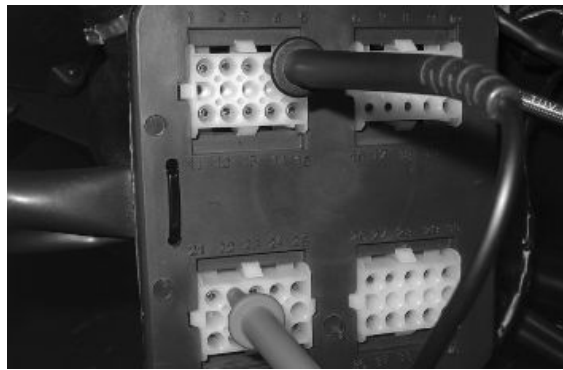

17

### Electric characteristic

Measured value =

$5 \pm 0.2$  V

Repeat the wiring and sensor continuity checks.

YES go to 18

18

### Electric characteristic

Measured value =

0 V

Repeat the sensor and circuit earth insulation check.

YES go to 19 NO go to 20

19 - Check the control unit connector.

Check the control unit power supply.

Replace the control unit, if necessary.

20 - Repair or replace the cable harness.

21 - Start the engine and check that voltage decreases gradually according to the temperature increase as per table.

YES go to 22 NO go to 23

22 - The temperature signal is conforming.

23 - Replace the temperature sensor.

**N.B.**

**FOR A MORE ACCURATE CHECK OF THE SENSOR, REMOVE IT FROM THE ENGINE AND CHECK ITS RESISTANCE AT CONTROLLED TEMPERATURE.**

**USING A SUITABLE CONTAINER, IMMERSE THE METAL PORTION OF THE SENSOR IN WATER, HEAT GRADUALLY AND READ THE TEMPERATURE AND RESISTANCE VALUES.**

**CHECK THE MATCHING AS PER TABLE**

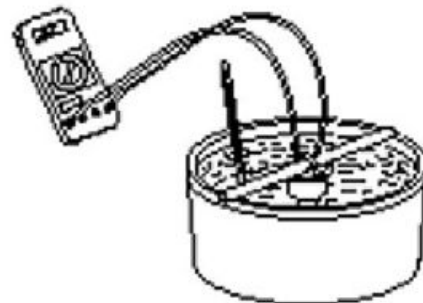

## Intake air temperature sensor

### Electric characteristic

**TERMINALS:** 18 - 22

**CONDITIONS:** Intake air temperature 20°

**STANDARD:** With connected sensor:  $3750 \pm 200 \Omega$

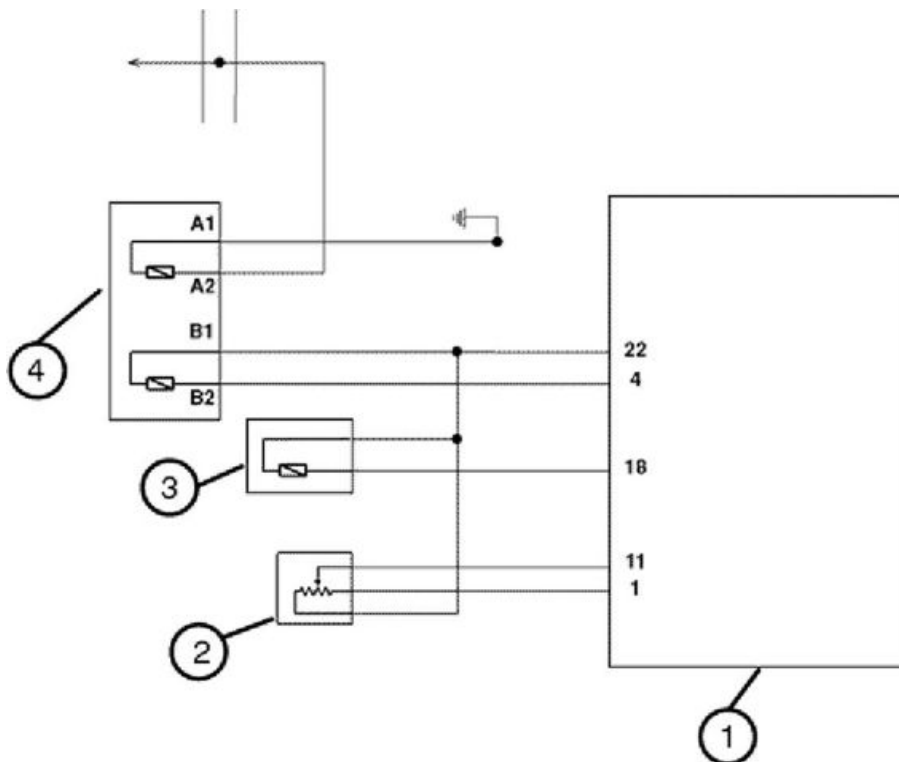

### CIRCUIT LAYOUT

	Specification	Desc./Quantity
1	Electronic control unit	
2	Valve position sensor	
3	Air temperature sensor	
4	Fluid temperature sensor	

The sucked air temperature sensor is installed in the bottom side of the throttle body on the filter box side.

The sensor is an NTC and has the same functional layout as the coolant temperature sensor.

This signal is used to optimise the engine performance. Anyway, this data is less important than the coolant temperature signal.

A failure of this circuit causes the control unit to turn on the injection warning light and activate the safety control, thereby ensuring the engine operation.



To check the sensor and related circuit, proceed as follows:

**1** - Connect the diagnostic tester.

Select the function "**ERRORS**" in the menu.

Check whether there are any indications regarding the sucked air temperature sensor.

YES go to 3 NO go to 2

### Specific tooling

#### 020460Y Scooter diagnosis and tester

**2** - The EMS system has received no indications of temperatures out of the range of possible values.

If you suspect a wrong temperature indication, proceed to perform the following check.

**3** - Before checking the sensor and the relevant circuit, wait until the engine has cooled down and the scooter has set to the working area temperature.

YES go to 4

**4** - Set the switch to "**ON**" with switch to "**RUN**" and side stand raised. On the diagnostic tester, select the «**PARAMETERS**» menu.

YES go to 5

**5** - Check the following values:

coolant temperature

intake air temperature

ambient temperature indicated by the digital instrument.

The three indications are equal or they are slightly different (e.g. 1° C).

YES go to 6 NO go to 7

**6** - The intake air temperature sensor is providing an incorrect information.

**7** - Install the special tool. Do not connect the control unit connector.

YES go to 8

### Specific tooling

#### 020481Y Control unit interface wiring

**8** - Disconnect the intake air temperature sensor connector.

Measure the resistance between the sensor terminals. Check that the resistance matches the values declared according to the temperature.

### TEMPERATURE RESISTANCE

	Specification	Desc./Quantity
1	9,6 KΩ	-10° C
2	5,975 KΩ	0
3	3,81 KΩ	+10° C
4	2,5 KΩ	+20° C
5	1,68 KΩ	+30° C

YES go to 10 NO go to 9

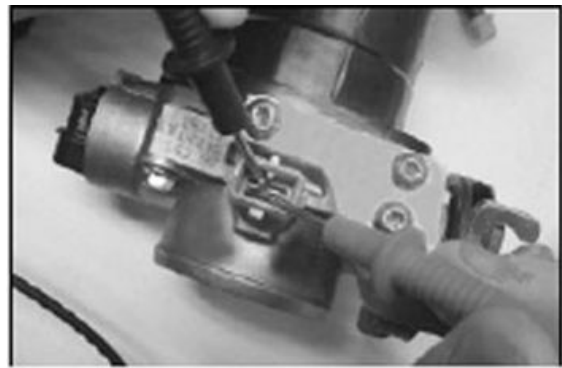

**9** - Replace the sensor.

**10** - Connect the sensor connector and repeat the resistive check at terminals 18 and 22.

**Electric characteristic**

**18-22 =**

Resistance equal to the value directly detected at the sensor.

YES go to 13 NO go to 11

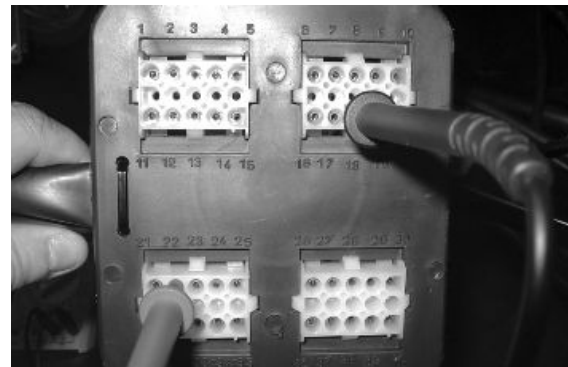

**11** - If slightly higher values are detected, check the connectors.

If infinite resistance is detected (>1MΩ), check the continuity of the two lines with disconnected connectors.

**Electric characteristic**

**Grey-white-18 =**

0 Ω (continuity)

**Light blue/green-22 =**

0 Ω (continuity)

YES point 12

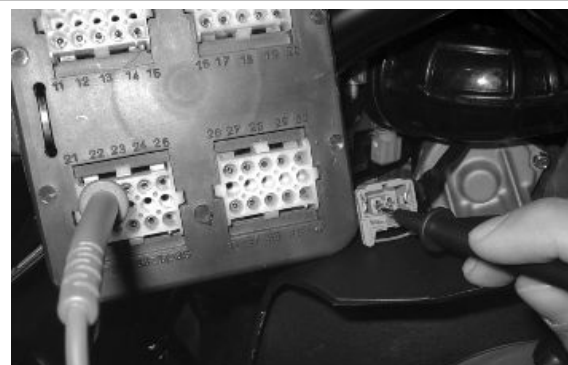

12 - Repair or replace the cable harness.

YES go to 10

13 - Check that the sensor circuit is earth insulated.

**Electric characteristic**

18-23 =

infinite (>1MΩ)

22-23 =

infinite (>1MΩ)

YES go to 15 NO go to 14

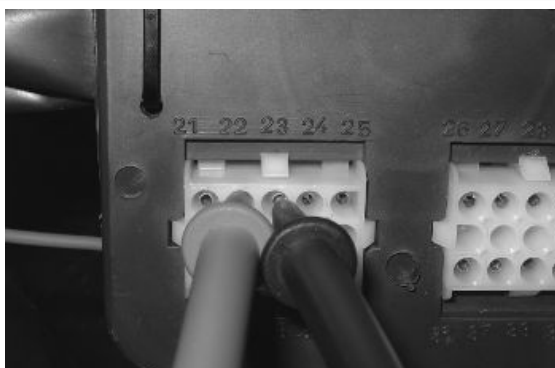

14 - Repair or replace the wiring. Check the valve position and the fluid temp. lines.

YES go to 13

15 - Connect the special tool to the control unit.

Set the switch to "ON" with switch in "RUN" and side stand raised.

YES go to 16

**Specific tooling**

**020481Y Control unit interface wiring**

16 - Measure voltage at terminals 18 and 22.

**Electric characteristic**

18-22 =

V as in the table.

**TEMPERATURE VOLTAGE**

	Specification	Desc./Quantity
1	X V	-10° C
2	X V	0
3	X V	+10° C
4	X V	+20° C
5	X V	+30° C
6	X V	+80° C

YES go to 21 NO go to 17

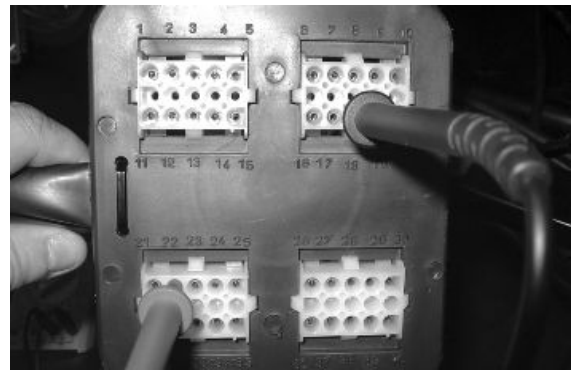

**17**

**Electric characteristic**

**Measured value =**

5±0.2 V

Repeat the wiring and sensor continuity checks.

YES go to 18

**18**

**Electric characteristic**

**Measured value =**

0 V

Repeat the sensor circuit earth insulation check.

YES go to 19 NO go to 20

**19** - Check the control unit connector. Check the control unit power supply. Replace the control unit, if necessary.

**20** - Repair or replace the cable harness.

**21** - Start the engine and check that voltage decreases gradually according to the air filter box temperature increase.

**N.B.**

**WITH MILD WEATHER, 30° C CAN BE EASILY REACHED AFTER A FEW MINUTES OF STOP WITH IDLE ENGINE.**

## Pressure sensor

This sensor does not have a system since it is directly installed into the control unit.

The sensor allows the control unit to optimise the engine performance based on altimetric variations.

To check the sensor, proceed as follows:

**1** - Connect the diagnostic tester.

Select the function "**ERRORS**" in the menu.

Check whether there are any indications regarding the pressure sensor.

YES go to 2 NO go to 3

### Specific tooling

#### 020460Y Scooter diagnosis and tester

**2** - Replace the injection control unit.

**3** - Select the menu on the "**PARAMETERS**" function.

Check that the pressure value in mm/Hg matches that of another scooter or of an external barometer.

### Electric characteristic

**Max error:**

± 20 mmHg

YES go to 4 NO go to 5



**4** - The ambient pressure signal is correct.

**5** - Replace the injection control unit.

## Throttle valve opening sensor

Throttle position sensor (t.p.s.)

### Electric characteristic

**TERMINALS:** 1 - 22

**CONDITIONS:** Switch set to "ON"



**STANDARD:** 5 V  
**TERMINALS:** 11 - 22

**CONDITIONS:** Opening the throttle gradually

**STANDARD:** Volt= Progressive increase

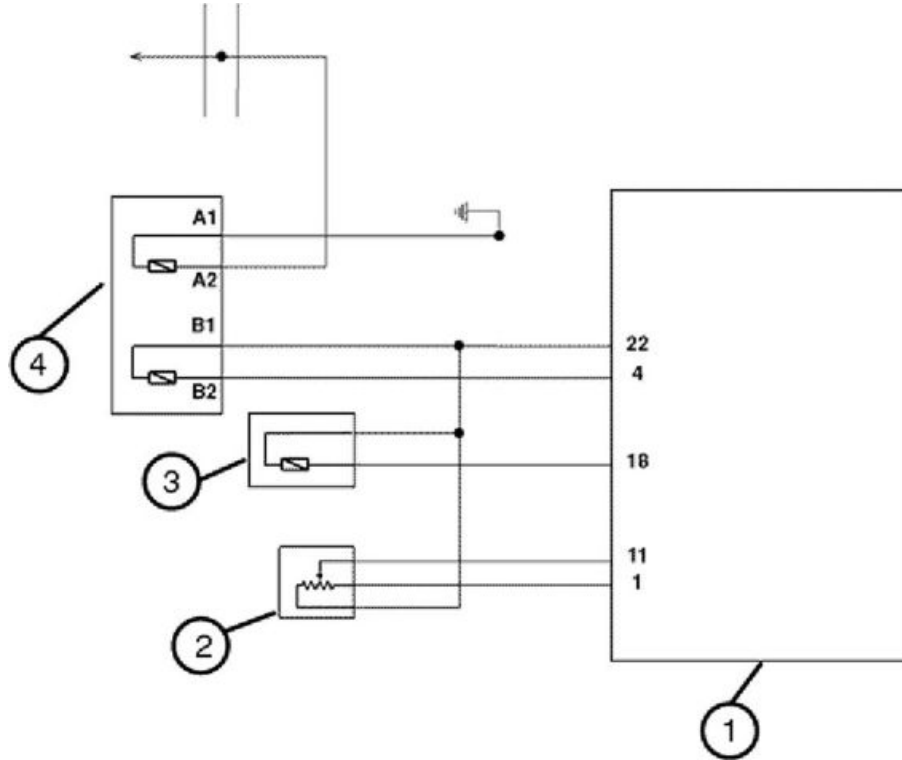

**CIRCUIT LAYOUT**

	Specification	Desc./Quantity
1	Electronic control unit	
2	Valve position sensor	
3	Air temperature sensor	
4	Fluid temperature sensor	

The throttle valve position sensor is not removable and is installed on the throttle body.

This sensor receives a 5-V power supply from the control unit and transmit a gradually increasing voltage to the same, with an increase of the throttle valve opening. The control unit converts this voltage at an angular position of the valve.

The engine rpm and the throttle valve position are the two basic signals for the engine management.

A failure of this circuit causes the switching on of the injection telltale light and the tripping of the safeties. In these conditions, the engine works,



even though not in an optimum way, always safeguarding the catalytic converter integrity.

The throttle valve position signal is especially important at the small valve openings. These areas are also where the sensor works more frequently, and therefore they require more frequent checks after a high number of kilometres run.

To check the sensor and related circuit, proceed as follows:

**1** - Connect the diagnostic tester.

Set the switch to "ON" with switch to "RUN" and side stand raised.

Select the tester menu on the «**ERRORS**» function.

Check whether the control unit has detected any failures relating to the throttle valve position signal.

YES go to 6 NO go to 2

### Specific tooling

#### 020460Y Scooter diagnosis and tester

**2** - Select the diagnostic tester menu on the "**PARAMETERS**" function.

Check whether the control unit recognises the extreme positions:

Throttle valve to minimum

Throttle valve to maximum

YES go to 4 NO go to 3



**3** - Check the adjustment of the throttle valve control flexible transmissions. Fix or replace, if required.

YES go to 2

**4** - Gradually open the throttle valve, check that the mV value increases progressively and proportionally with the opening variation.

YES go to 5 NO go to 6

**5** - The throttle valve position signal is conforming.

**6** - Connect the special tool to the injection system.

Do not connect the tool to the control unit.

Disconnect the throttle valve position sensor connector.

Check the continuity between the connector's terminals and the relevant pins on the control unit.

### Specific tooling

## 020481Y Control unit interface wiring

### Electric characteristic

**Light blue/green-22 =**

0  $\Omega$  (continuity)

**Brown-yellow-1 =**

0  $\Omega$  (continuity)

**Orange-light blue-11 =**

0  $\Omega$  (continuity)

YES go to 8 NO go to 7

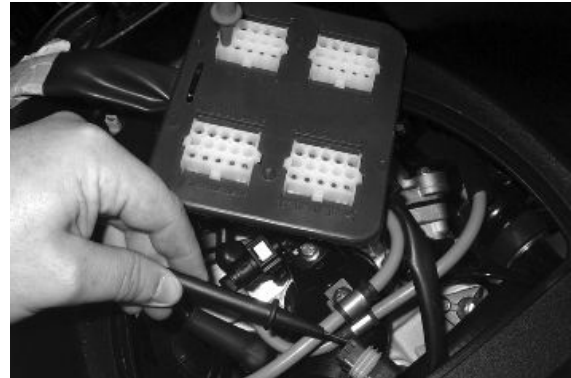

**7** - Repair or replace the injection wiring.

YES go to 6

**8** - Check the earth insulation of the three circuit lines.

### Electric characteristic

**22-23 =**

$\Omega$  infinite (>1M)

**1-23 =**

$\Omega$  infinite (>1M)

**11-23 =**

$\Omega$  infinite (>1M)

YES go to 10 NO go to 9

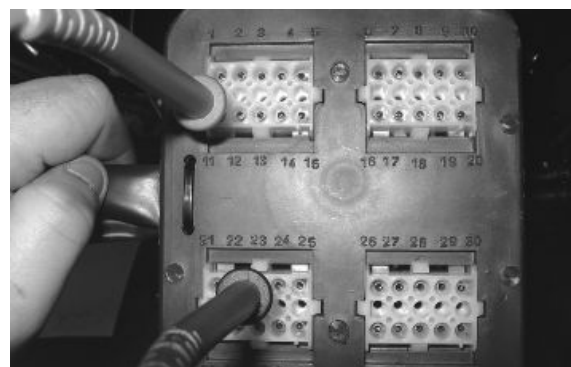

**9** - Repair or replace the injection wiring

YES go to 8

**10** - Connect the special tool to the control unit.

Set the switch to "**ON**" with switch to "**RUN**" and side stand raised.

Measure voltage between terminals 1 and 22 of the special tool.

### Specific tooling

#### 020481Y Control unit interface wiring

#### Electric characteristic

1-22 =

5±0.2 V

YES go to 12 NO go to 11

11 - Check the control unit connector.

Replace the control unit, if necessary.

YES go to 10

12 - Connect the throttle valve position sensor connector.

Repeat the voltage measurement between terminals 1 and 22 of the special tool.

#### Electric characteristic

1-22 =

5±0.2 V

YES go to 13 NO go to 14

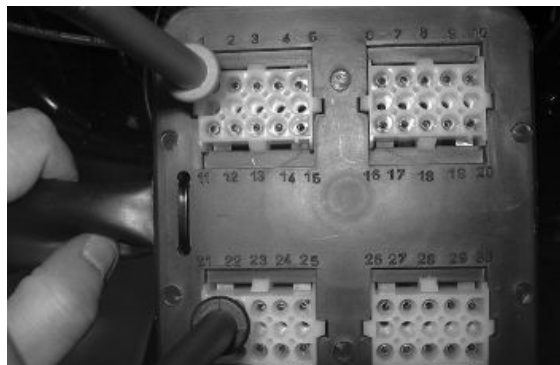

13 - Measure voltage between terminals 11 and 22. Gradually open the throttle valve and check that the voltage value increases progressively.

**N.B.**

**BY WAY OF AN INDICATION, VOLTAGE MAY VARY FROM APPROX. 700MV AT MINIMUM, AND ABOVE 4V AT MAXIMUM.**

#### Electric characteristic

11-22 =

V (progressive variation)

The possible variations of the limit values are caused by the sensor installation tolerances.

YES go to 15 NO go to 14

**14** - Replace the throttle body along with sensors and Stepper.

YES point 12

**15** - Check that the voltage measured at pins 11 and 22 matches that indicated by the diagnostic tester set to "**PARAMETERS**".

YES go to 16 NO go to 17

**16** - The throttle valve position sensor and relevant circuit are conforming.

**17** - Replace the control unit.



## Zeroing the throttle

### Resetting the throttle valve position signal (TPS reset)

The throttle body is supplied with throttle valve position sensor and is pre-calibrated.

Pre-calibration entails regulating the minimum opening of the throttle valve to obtain a certain flow of air under pre-set reference conditions.

Pre-calibration ensures optimal air flow to control idling.

**This regulation must not be tampered with in any way whatsoever.**

The injection system will complete the management of the idling through the Stepper motor and the variation of the ignition advance.

The throttle body after the pre-calibration has an opened valve with an angle that can vary depending on the tolerances of the machining of the pipe and the valve itself.

The valve position sensor can also assume various fitting positions. For these reasons the mV of the sensor with the valve at idle can vary from one throttle body to another.

To obtain the optimum fuel mixture, especially at small openings of the throttle valve, it is essential to match the throttle body with the control unit following the procedure known as TPS resetting.

With this operation we inform the control unit, as the starting point, of the mV value corresponding to the pre-calibrated position. The control unit will recognise such value as angle 5.24°.

To reset, proceed as follows:

Connect the diagnostic tester.

Set the switch to "ON" with switch in "RUN" and side stand raised.

Select the functions of the diagnostic tester on «TPS RESET».

### Specific tooling

**020460Y Scooter diagnosis and tester**



Make sure that the throttle valve with the control is supporting the stop screw.



Guaranteeing that this position will be kept, send a confirmation for the TPS reset procedure.



Select the "PARAMETERS" function and check that the TPS reset "YES" is displayed.



Reset should be performed in the following cases:

- on first fitting.
- in case of replacement of the throttle body
- if the injection control unit is replaced.

**N.B.**

THE TPS RESETING PROCEDURE MUST NOT BE CARRIED OUT WITH A USED THROTTLE BODY BECAUSE POSSIBLE VALVE WEAR AND STOP WEAR FOR THE MINIMUM OPENING MAKE THE AIR FLOW DIFFERENTLY FROM THAT OF PRE-CALIBRATION.

Step motor

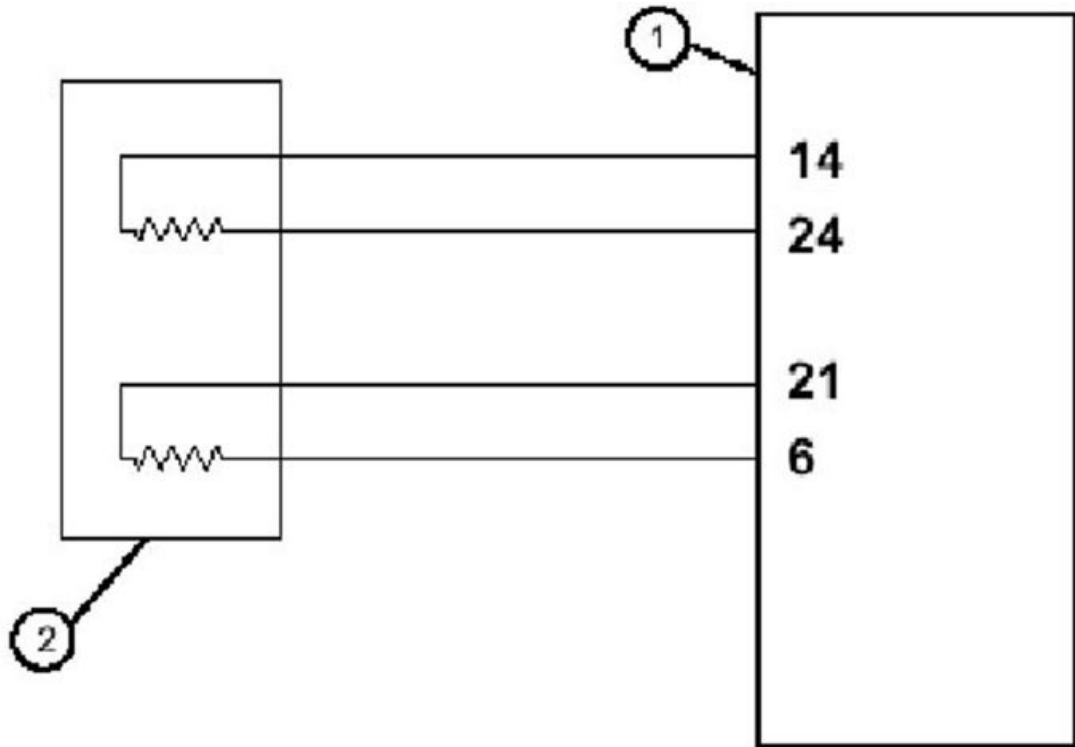

**CIRCUIT LAYOUT**

	Specification	Desc./Quantity
1	Electronic control unit	
2	Stepper motor	Stepper motor

The throttle body is provided with an auxiliary air circuit. This is enabled by a piston valve controlled by a Stepper motor.

The Stepper is powered by the control unit only when the opening must be changed.

The revolution is divided into portions called "steps".

By changing the opening "steps" it is possible to properly feed the engine to facilitate the start-up procedure and adjust the air feeding with cold engine. When the engine reaches the working temperature, the Stepper partly closes again.



To prevent wear of the adjustment piston, operation at full speed is obtained with a minimum opening of 43 - 45 "steps".

To recover possible adjustments, every switching to "OFF" causes the piston to close up to end of travel and to open up again by a fixed number of steps (self-reset).

When the control unit changes the Stepper opening "steps" it also changes the injection time to ensure proper ignition.

The engine idle speed is practically stabilised at 1550-50 rpm. After a hot start-up step you can perceive the first increase in the revolutions and the subsequent closing of the Stepper to stabilise the speed.

In case of irregular speed, before carrying out electric checks inspect the throttle valve and the auxiliary air circuit cleaning.

To check the Stepper and the relevant circuit, proceed as follows:

1 - Connect the diagnostic tester.

Set the switch to "ON" with switch to "RUN" and side stand raised.

Lift the scooter on the central stand. Select the function "ERRORS" in the menu.

Check whether the control unit has detected any failures relating to the Stepper circuit.

YES go to 8 NO go to 2

### **Specific tooling**

#### **020460Y Scooter diagnosis and tester**

2 - Select the menu on the "PARAMETERS" function. Check the number of "steps" programmed by the control unit to obtain start-up. This setting is a function of the engine temperature.

### **Electric characteristic**

**20° C =**

approx. 135 - 140 steps



YES go to 3 NO go to 4



**3** - Start the engine and let it warm up.

With a coolant temperature of more than 70°C, the control unit must control the Stepper with about 45 «steps».

YES go to 5 NO go to 4



**4** - Check the coolant temperature sensor signal. Check the control unit, if necessary.

**5** - Select the menu on the «**ACTIVE DIAGNOSIS**» function. Select «**STEPPER**» diagnosis. Start the diagnosis with idle engine at the working temperature. Check whether the Stepper controls some revolution variations and wait for the diagnostic tester response.

**N.B.**

**THE ECU ENABLES THE DIAGNOSIS ONLY WHEN THE IDLE SPEED IS WITHIN THE SPECIFICATIONS.**

YES go to 6 NO go to 8



**6** - Test successful. Variations of revolutions perceived.

YES go to 7 NO go to 9

**7** - Stepper and relevant circuit efficient.

**8**- Test failed. No variations of revolutions. Check the Stepper circuit. Disconnect the Stepper connector. Check the resistance of the Stepper circuits by connecting the tester as indicated in the figure. The two measurements must have the same value.

**Electric characteristic**

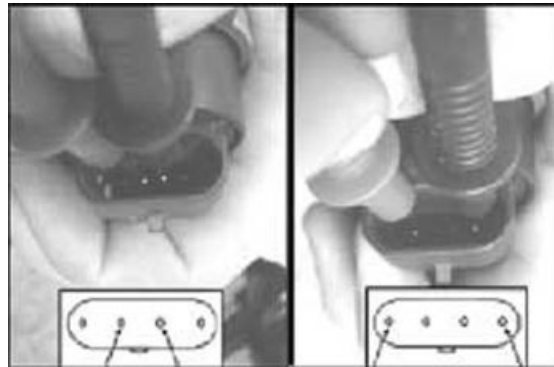
**Resistance =**approx. 51  $\Omega$ YES go to 11 NO go to 10**9 - Test successful.**

No variations of revolutions.

Remove the throttle body.

Check the auxiliary air circuit cleaning. Switch from "ON" to "OFF" and again to "ON" and check whether the piston valve moves. If the valve does not move, replace the throttle body.

**10 - Replace the throttle body****11 - Connect the special tool.**

For these checks, do not connect the special tool to the control unit. Check the continuity of the 4 power supply lines of the Stepper.

**Specific tooling****020481Y Control unit interface wiring****Electric characteristic****A Light blue-red-14 =**0  $\Omega$  (continuity)**B Orange-blue-6 =**0  $\Omega$  (continuity)**C Light blue-yellow-21 =**0  $\Omega$  (continuity)**D Light blue-black-24 =**0  $\Omega$  (continuity)

YES go to 12 NO go to 13

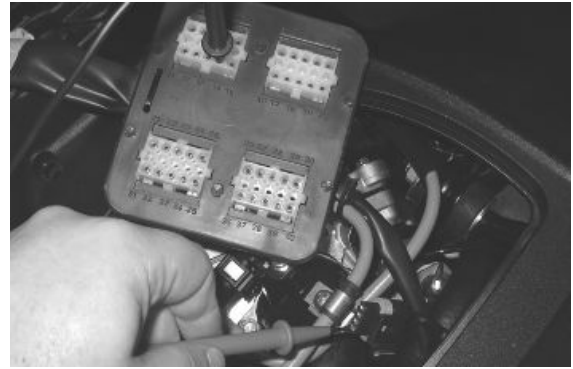

**12** - Check the earth insulation of the 4 Stepper lines.

**Electric characteristic**

**14-23 =**

>1 M $\Omega$  (infinite)

**6-23 =**

>1 M $\Omega$  (infinite)

**21-23 =**

>1 M $\Omega$  (infinite)

**24-23 =**

>1 M $\Omega$  (infinite)

YES go to 14 NO go to 13

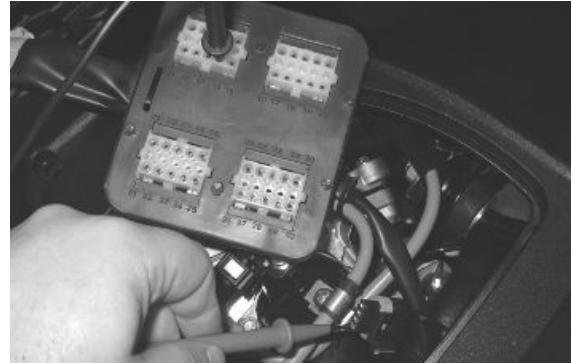

**13** - Repair or replace the wiring.

YES go to 11

**14** - Connect the Stepper connector.

Repeat the continuity check with the tool pins.

**Electric characteristic**

**14-24 =**

approx. 51  $\Omega$

**6-21 =**

approx. 51  $\Omega$

YES go to 16 NO go to 15

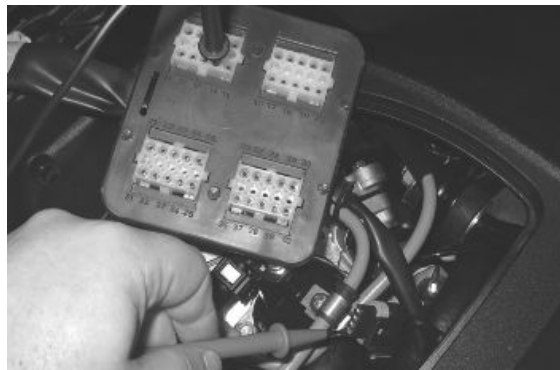

**15** - Check cable harness and connectors more carefully.

**16** - Connect the control unit connector.

Set the switch to «**ON**» with switch to «**RUN**» and side stand raised. Repeat the «**ON**» «**OFF**» «**ON**» switching.

Check the presence of voltage pulses on the Stepper command lines.

Set-up for direct voltage measurements.

**N.B.**

**PULSES ARE USED TO CHANGE THE STEPPER POSITION.**

**Electric characteristic**

**14-24 =**

V (pulses for a few seconds)

**6-21 =**

V (pulses for a few seconds)

After reaching the optimum position, the power supply voltage becomes null.

YES go to 17 NO go to 18

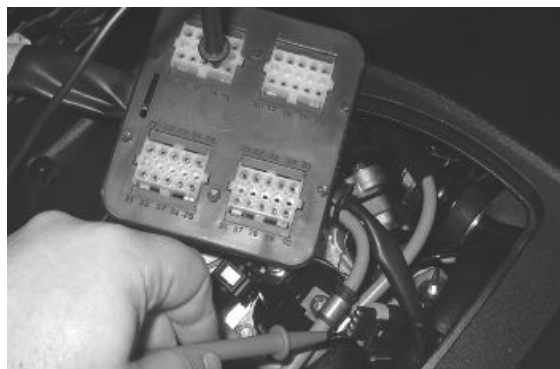

**17** - The Stepper circuit is efficient.

**18** - Check the control unit connector. Replace the control unit, if necessary.

## Lambda probe

**SIGNAL CHECK**

Install the electronic control unit interface wiring.  
 Start the engine and warm up until the electric fan switches on.

Use an analogue multimeter with a direct voltage scale measuring down to 2 V.

Connect the multimeter probes between pin 2 (-) and pin 8 (+)

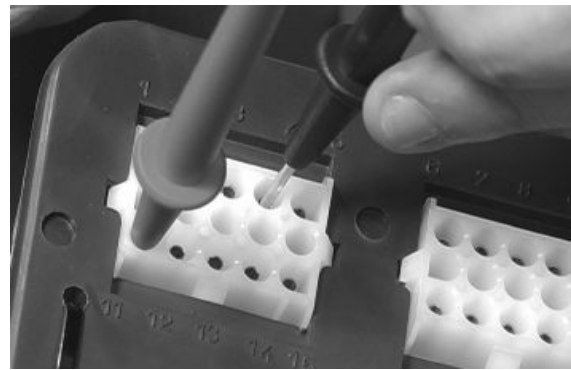

With the engine running at idle speed, check that the voltage oscillates between 0V and 1V

With the throttle valve completely open, the voltage is approx. 1V.

During the closing phase, the voltage is approx. 0V.

If the voltage remains constant, the sensor may be damaged. Remove the sensor and check that there are no oil or carbon deposits inside it..



### **Impianto elettroventilatore**

<b>TERMINALS</b>	<b>CONDITIONS</b>	<b>STANDARD</b>
5 - 23	Switch in position "ON" Switch on "RUN" Side stand raised Electric fan off	Battery voltage

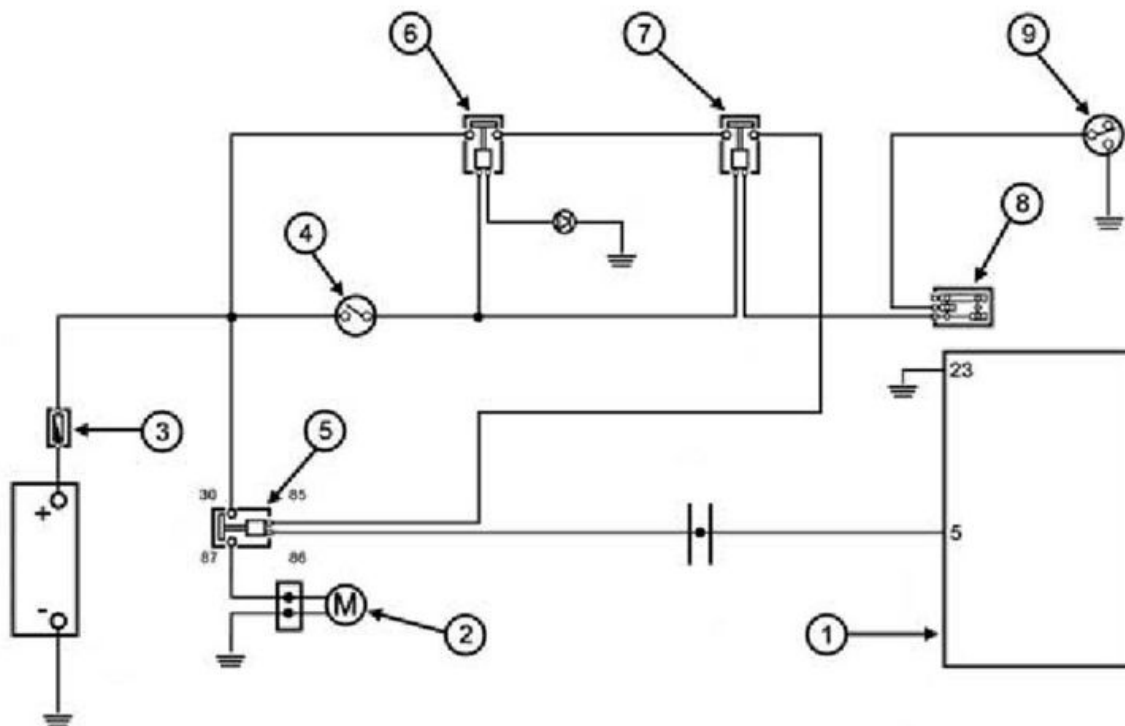

**CIRCUIT LAYOUT**

	Specification	Desc./Quantity
1	electronic control unit	
2	Electric fan	
3	Fuse	30A
4	Key switch	
5	Electric fan remote control switch	

The electric fan system is powered by a remote control switch connected to the continuous power supply controlled by the electronic control unit of the injection system.

The electronic control unit of the injection system controls the electric fan in relation to the measured engine temperature.

If prolonged running of the electric fan is noticed, check the following carefully before starting to check the electrical system:

- Coolant level in the expansion tank - bleeding of the inlet hose to the engine
- Bleeding of the outlet from the head
- Function of the thermostat
- Function of the pump

For these checks, see chapter "Cooling system".



To check the circuit, proceed as follows:

1 - Connect the diagnostic tester. Set the switch to "ON" with switch to "RUN" and side stand raised. Select the "ERRORS" function. Check whether the control unit has detected any failures relating to the electric fan control circuit.

YES go to 8 NO go to 2

2 - Select the menu on the "ACTIVE DIAGNOSIS" function. Activate the electric fan diagnostic function. Check acoustically for rotation of the electric fan. Wait for the exit from the diagnostic tester.

YES go to 3 NO go to 4



3 - Test successful. The fan is rotating.

YES go to 5

4- Test failed. The fan is not rotating.

YES go to 8 NO go to 6

5- The electric fan system is OK

6 - Test successful. The fan is not functioning

YES go to 7

7 - The remote control switch circuit is OK. Check the connections to the electric fan, the function of the contacts of the remote control switch, the positive lines, the negative line and the motor of the electric fan.

8 - Disconnect the remote control unit of the electric fan. Check the continuity of the excitation coil.

85 - 86 =  $100 \pm 50\Omega$

YES go to 10 NO go to 9



9 - Replace the remote control switch

YES go to 8

10 - Connect the special tool between the control unit and the system. Do not connect the electronic control unit

YES go to 11

11 - Check for positive battery voltage at pin 85 of the remote control switch connector.

85 (blue/grey) - 23 = Battery voltage with switch in position "ON"

YES go to 13 NO go to 12

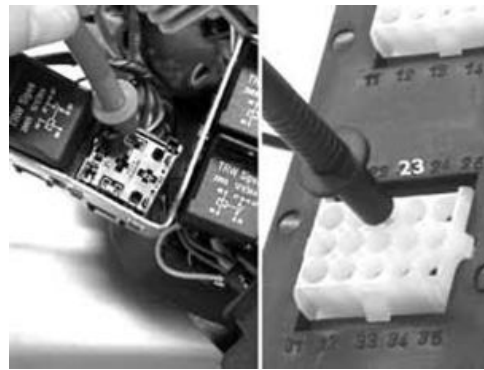

12 - Repair or replace the wiring.

13 - Leaving the remote control switch disconnected, check for continuity between pin 86 of the remote control switch connector and pin 5 of the electronic control unit.

86 (green/white) - 5 = 0Ω (continuity)

YES go to 14 NO go to 15

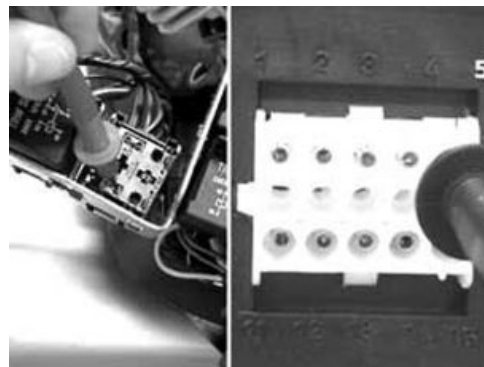

14 - Check the earth insulation.

5 - 23 >1 MΩ (infinite)

YES go to 16 NO go to 15

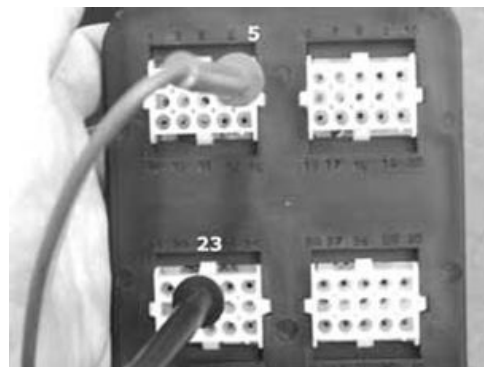

15 - Repair or replace the cable harness.

16 - Connect the remote control switch and check for battery voltage between terminals 5 and 23 with the key switch in position "ON".

5 - 23 = Battery voltage with panel in position "ON"

YES go to 17

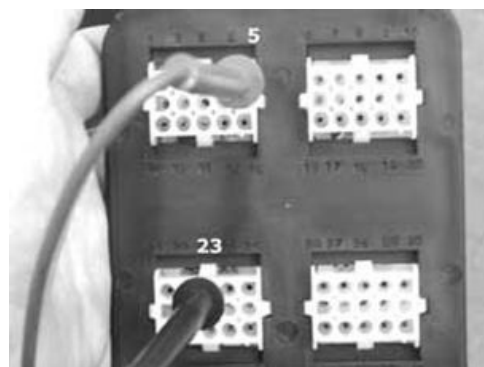

17 - Repeat the check with the electronic control unit connected and the engine cold.

5 - 23 = Battery voltage with panel in position "ON"



If the fault continues, replace the electronic control unit.

---

## INDEX OF TOPICS

**S**SUSPENSIONS

**SUSP**

This section is devoted to operations that can be carried out on the suspension.

## Front

### Removing the front wheel

- Loosen the two wheel axle locking screws shown in the figure.

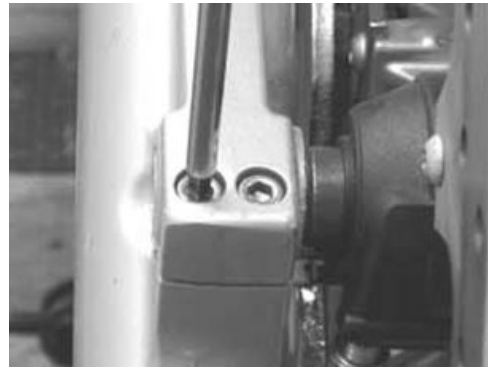

- Remove the wheel axle locking nut.
- Slide off the wheel axle and remove the wheel.
- Upon removal take care not to damage the sensor that detects movement in the odometer.
- Check that the wheel axle does not show signs of wear or deformations. If it does, replace it.



### Locking torques (N\*m)

**Wheel axle fixing screws: 6 ÷ 7 Nm Front wheel axle nut 45 - 50**

### Front wheel hub overhaul

Check that the wheel bearings do not show signs of wear.

If you have to replace the wheel bearings, proceed as follows:

- Remove the 2 bearings on the odometer movement sensor side using the pliers 14 or 34 and the driver, part 9.
- Remove the inside spacer.



### Specific tooling

**001467Y034 Pliers to extract ø 15-mm bearings**

**001467Y014 Pliers to extract ø 15-mm bearings**

**001467Y009 Driver for OD 42-mm bearings**

- Support the front wheel with two wooden pegs that prevents scratching in case of contact with the rim.
- Insert the punch (consisting of adaptor handle, 15 mm adaptor and guide) on the odometer movement sensor side to facilitate removing the left side bearing and the spacer bushing.



### Specific tooling

**020376Y Adaptor handle**

**020456Y ø 24 mm adaptor**

**020412Y 15 mm guide**

- Heat the seat of the bearing on the left side with the heat gun.

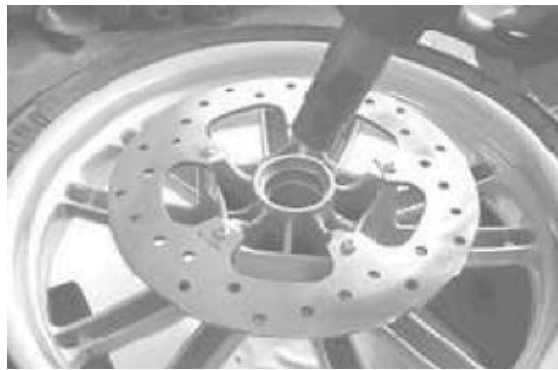

- Fit the bearing using the punch consisting of adaptor handle, 42x47 mm adaptor and 15 mm guide, and drive it until it stops.



- Reinsert the spacer bushing on the brake disc side using the specific tool and drive it until it stops.



### Specific tooling

**020376Y Adaptor handle**

**020359Y 42x47-mm adaptor**

**020412Y 15 mm guide**

**020201Y Spacer bushing driving tube**

- Turn over the wheel and insert the inside spacer with the section fitted with the Seeger ring facing the left side bearing previously installed.
- Heat the seat of the bearing on the odometer movement sensor side with the heat gun.



- Fit the 2 bearings using the punch consisting of adaptor handle, 32x35 mm adaptor and 15 mm guide, and drive it until it stops.



### Specific tooling

**020376Y Adaptor handle**

**020357Y Adaptor 32 x 35 mm**

**020412Y 15 mm guide**

## Refitting the front wheel

- To refit, carry out the removal operations but in reverse order, observing the prescribed torques.
- Place the odometer movement sensor until the reference correctly fits into its slot.

### Locking torques (N\*m)

**Front wheel axle 45 ÷ 50 Safety screw on fork leg 6 ÷ 7**



---

## Front fork

---

### Removal

---

- Remove the front wheel.
- Remove the front mudguard
- Remove the front brake calliper
- Remove the front and rear handlebar covers.
- Remove the pin mounting the handlebar to the steering tube.
- Remove the handlebar and rest it on the shield back plate.



Using the special tool, loosen and remove the upper ring nut, the spacer washer and the counter-ring nut.

- Extract the fork.

**N.B.**

**TAKE CARE TO SUPPORT THE FORK SO AS TO PREVENT IT FROM COMING OFF ABRUPTLY**

#### Specific tooling

**020055Y Wrench for steering tube ring nut**

---



### Overhaul

---

#### Check pump unit

- Check that the oil holes on the pumping are free from clogging.
- Check that the sealing snap ring is not damaged.

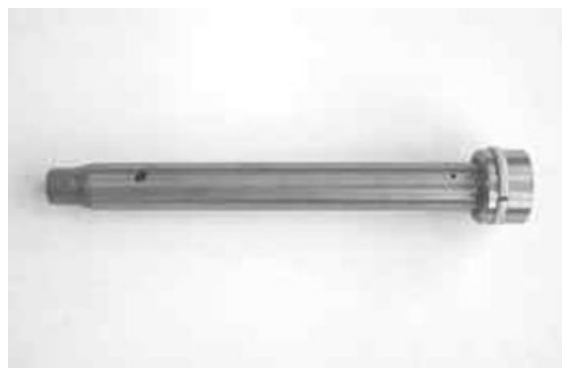

---

**Check the spring length**

- Check the length "A" of the spring.

**Characteristic****Standard spring length:**

291.6 mm

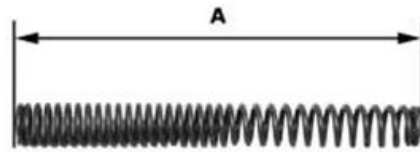

---

**Servicing tapered bearing seats**

- Check that the seats and the tapered bearings exhibit no scratches or wear.

**N.B.****THE TAPERED BEARING SEATS SHOULD BE REMOVED ONLY IF STRICTLY NECESSARY.**

In case of replacement, proceed as follows:

- Using a bearing removal punch, inserted from the bottom, remove the top seat on the steering head. Then, remove the bottom seat of the tapered bearing inserting the punch from the top of the headstock.

**Specific tooling****020004Y Punch for removing fifth wheels from headstock**

---

**Servicing fork stems**

- Using an inside 17 mm hexagonal spanner, loosen the top stem closing cap.



- Loosen the stem support clamp and remove fork leg and stem.



- Remove the spring.
- Drain the oil.
- Remove the screw with copper washer shown in the figure. To prevent the pumping member rotation, insert an inside 22 mm hexagon spanner into the stem.
- Remove the pumping member.



- Remove the dust guard ring using a screwdriver as shown in the figure.

**N.B.**

**BE CAREFUL NOT TO DAMAGE THE DUST GUARD AND THE STEM.**



- Remove the oil guard safety lock using a screwdriver.
- Repeatedly actuate the stem to remove it from the fork leg.





- Extract the oil guard "D", the abutment washer "C" and the top bushing "B".
- Widen and remove the bottom bushing "A".

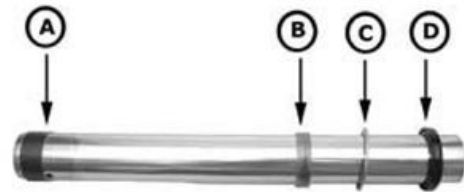

## Refitting

### Refitting stems on fork legs

Preassemble the stem as indicated:

- Install the bushing from the bottom of the stem



- Insert the following from the top of the stem:

- 1 Bushing "B"
- 2 Abutment washer "C"
- 3 Oil guard "D"

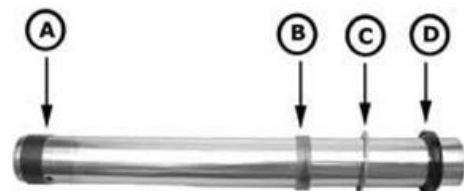

- Insert the pumping member guiding bushing at the bottom end of the stem.



- Insert the stem into the casing being careful not to let the guiding bushing come out of the stem.
- Move the oil guard in abutment using a tube.

**TUBE SIZE**

Specification	Desc./Quantity
Inside:	44 mm
Outside:	51 mm
Height:	approx. 105 mm



- Insert the contrast spring into the pumping member.
- Insert the pumping member into the stem.
- Insert the stem into the fork leg being careful not to let the guiding bushing come out of the stem.
- Insert and screw the pumping member screw with a new copper washer and tighten to the prescribed torque.

**CAUTION**

TO PREVENT THE PUMPING MEMBER ROTATION, INSERT AN INSIDE 22 MM HEXAGON WRENCH INTO THE STEM.

**Locking torques (N\*m)**

**Pumping element fixing screw 25 - 35**

- Pour recommended oil into the stem.

**Recommended products**

**AGIP FORK 7,5W Oil for front fork**

Hydraulic oil SAE 7,5W

**Characteristic**

**Amount oil:**

195 ± 3 cc

- Insert the spring with the thickest turns at the bottom.
- Insert the stem into the fork clamp.
- Tighten the clamp to screw the top stem closing cap.
- Check that the sealing ring on the cap is in good working order, then tighten the cap on the stem to the prescribed torque.



### Locking torques (N\*m)

#### Stem upper cap 35 - 55

- Loosen the fork clamp screws and move the stem closing cap in abutment with the clamp.
- Tighten the clamp screws to the prescribed torque.



### Locking torques (N\*m)

#### Fork clamp screws 20 ÷ 25

- Grease the tapered bearing using the specified product.

### Recommended products

#### AGIP GREASE PV2 Grease for the steering bearings, pin seats and swinging arm

White anhydrous-calcium based grease to protect roller bearings; temperature range between -20 C and +120 C; NLGI 2; ISO-L-XBCIB2.



- Insert the fork into the headstock.
- Insert the tapered bearing after applying the specified product.

### Recommended products

#### AGIP GREASE PV2 Grease for the steering bearings, pin seats and swinging arm

White anhydrous-calcium based grease to protect roller bearings; temperature range between -20 C and +120 C; NLGI 2; ISO-L-XBCIB2.



- Using the special tool, tighten the first ring-nut on the steering tube to a holding torque, then tighten completely.

**Locking torques (N\*m)****Holding torque of lower ring nut 20 ÷ 25**

- Tighten to the prescribed torque.

**Locking torques (N\*m)****Steering lower ring nut 10 - 13 \*\***

- Install the space washer.
- Using the special tool, tighten the second locking ring nut on the steering tube to the prescribed torque.

**Locking torques (N\*m)****Upper steering ring nut 36 - 39**

- Install the handlebars on the steering tube, paying attention to the centring, aligning the recess on the handlebar with that on the steering tube as shown in the figure.

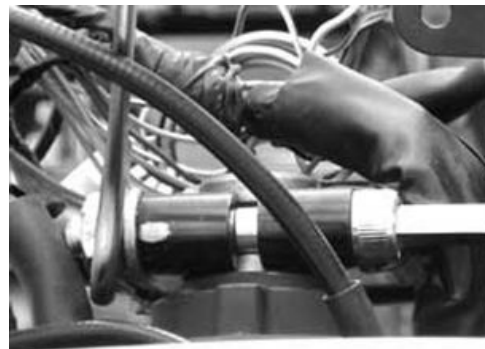

- Tighten the handlebar fixing screw on the steering tube to the prescribed torque.
- Install the front and rear handlebar covers as described in the section "Scooter body".
- Install the front mudguard
- Install the front wheel.
- Install the front brake callipers.
- Tighten the retaining screws of the brake calliper to the support.

**Specific tooling****020055Y Wrench for steering tube ring nut****Locking torques (N\*m)**

**Fixing screw handlebar to steering tube 45 ÷ 50 Holding torque of lower ring nut 20 ÷ 25 Upper steering ring nut 36 - 39 Steering lower ring nut 10 - 13 \*\* Front brake calliper mounting on fork 20 ÷ 25 Front brake disc mounting 11 ÷ 13 Plastic protection retaining screw 5 - 6**

---

**Steering bearing**

---

**Removal****Service of tapered bearing on fork**

- Check that the tapered bearing on the fork exhibits no deformations or wear.

**THE BEARING SHOULD BE REMOVED ONLY IF STRICTLY NECESSARY.**

---

---

In case of replacement, proceed as follows:

- Support the fork in a vice.
- Insert the contrast plate in the upper end of the steering tube



- 
- Insert the special tool as shown in the figure.



- 
- Insert the retaining band of the two half-rings.



- 
- Using a 19 mm hexagonal spanner, extract the roller bearing.

### **Specific tooling**

**020458Y Puller for lower bearing on steering tube**



---

## Refitting

### Reassembly of steering tapered bearing seats

Using the special tool, reassemble the tapered bearing housings on the head as described below:

- Place a new top housing on the head and a new bearing seat on the bottom side.
- Insert the screw of the special tool set-up with the adapters for inserting bearing and seat, into the steering head, as shown in the figure.
- Using two 24 mm wrenches, tighten the screw to move the two seats in abutment.

**N.B.**

**ALWAYS USE A NEW BEARING AND A NEW SEAT.**

### Specific tooling

**001330Y Tool for fitting steering seats**



---

### Reassembly of tapered bearing in steering tube

- Insert the a new plate and a new dust guard in the steering tube
- Insert the a new tapered bearing in the steering tube
- Using the special tool and a mallet to move the dust guard and the bearing in abutment.

### Specific tooling

**006029Y Punch for fitting fifth wheel seat on steering tube**



---

## Rear

---

---

## Removing the rear wheel

- Remove the muffler support arm
- Remove the spacer on the gear shaft.



- 
- Loosen the five gear shaft fastening nuts using the rear brake.



---

## Refitting the rear wheel

- For reassembly, perform the previous operations in the reverse order

### Locking torques (N\*m)

Wheel fastening screws 33 - 37

---

## Swing-arm

---

### Removal

- Extract the left bearing using the special tool.

#### Specific tooling

001467Y006 Pliers to extract 20 mm bearings

001467Y031 Bell

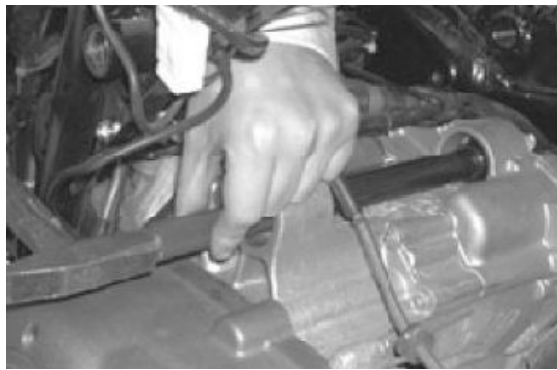

- Extract the right bearing using the modular punch through the left bearing seat (removed before).

**Specific tooling****020363Y 20 mm guide****020375Y Adaptor 28 x 30 mm****020376Y Adaptor handle**

- Remove the helmet compartment.
- Remove the air filter.
- Remove the rear mudguard.

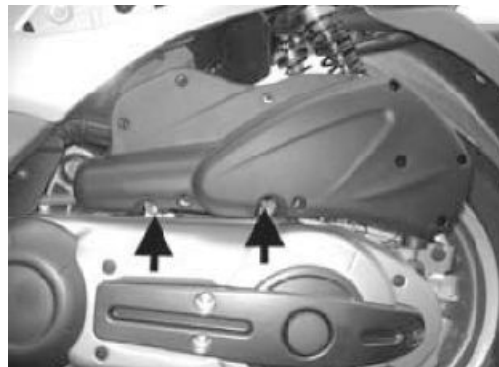

- Remove the nut and the washer mounting the swinging arm/engine pin and tie rod.



- Remove the locking nut, the washer and the tie rod buffer.





- Suitably support the engine using a jack under the oil sump.
- Remove the nut of the pin mounting the swinging arm to the chassis.

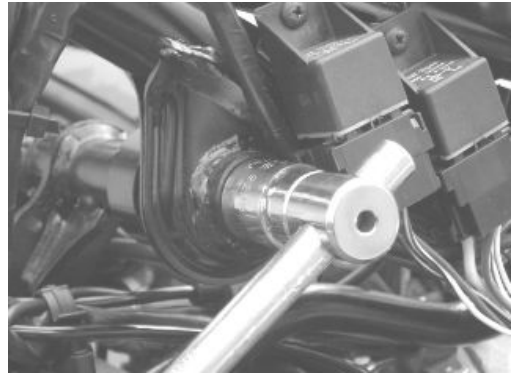

- Remove the lock nut, then using a 15-mm fork spanner, loosen the pin mounting the swinging arm to the chassis.

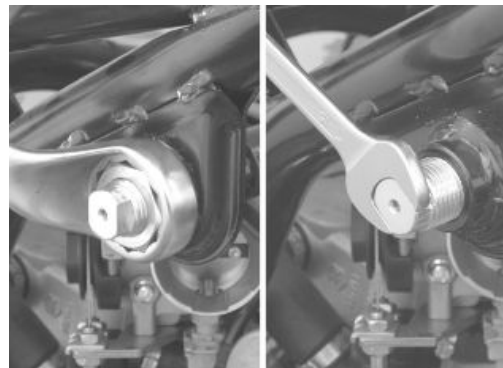

- Remove the swinging arm from the chassis and remove the shaped washer.



- Loosen the rear shock absorber mounting bolts.

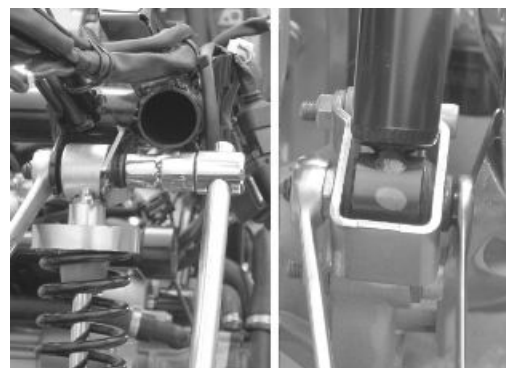

- Move the engine backwards as much as piping and transmissions allow, at the same time move the front of the engine leftwards to allow removing the tie rod (with washer and pad) from the chassis and from the pin mounting the swinging arm to the engine.



- Prevent the rotation of the pin connecting the swinging arm to the engine using a 19-mm fork spanner.
- Remove the nut and the washer from the scooter left side.

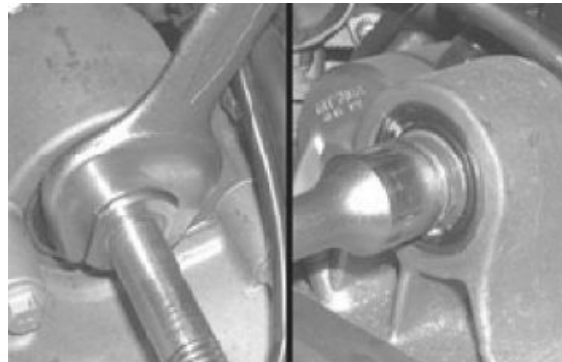

- Pull out the pin from the right side and remove the swinging arm with the washer on the right.

**N.B.**

**CHECK THAT THE SWINGING ARM DOES NOT INTERFERE WITH THE THROTTLE BODY COMPONENTS IF PULLED USING THE SPACER BUSHING.**

**N.B.**

**IF NECESSARY, REMOVE THE CABLE HARNESS SUPPORT BRACKET MOUNTING SCREW.**

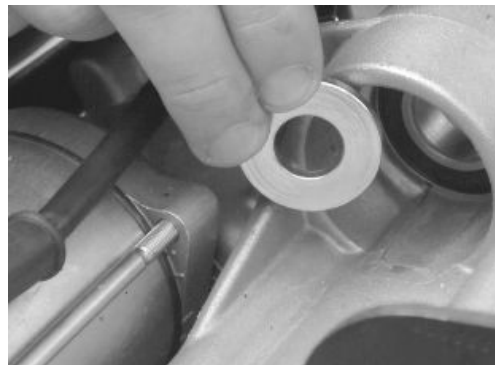

- Remove the bushing from the bearing on the engine left support.



Check that the following components are not worn or dented:

- Engine crankcase supports
- Ball bearing with bushing on swinging arm
- Roller bearing on swinging arm

Check that the chassis connecting pin exhibits no wear or dents on the roller bearing connection:

In case of irregularities, replace the pin and the roller bearing.

- Check that the pin connecting the swinging arm to the engine exhibits no wear at the right bearing housing connection:

#### Characteristic

Diameter of shaft:

Ø 18 -0.034 mm

Diameter of pin:

Ø 20 -0.041 mm

---

## Overhaul

- Properly support the swinging arm in the vice.
- Remove the Seeger ring.



- Remove the ball bearing bushing.



- Extract the ball bearing using the special tool.

#### Specific tooling

001467Y017 Driver for OD 36 mm bearings

001467Y034 Pliers to extract Ø 15-mm bearings



- Extract the roller bearing using the special tool.

**N.B.**

**POSITION THE PLIERS FOR EXTRACTING UNDER THE UPPER EDGE OF THE ROLLER BEARING.**

**Specific tooling**

**001467Y010 Driver for OD 25 mm bearings**

**001467Y019 Extraction pliers for  $\varnothing$  18 mm bearings**

**Refitting**

- Lubricate the inside tracks of the bearings on the crankcase.
- Lubricate the roller bearing into the swinging arm.
- Lubricate the bearing connection on the swinging arm/engine pin.

Lubricate the roller bearing connection on the swinging arm/chassis pin.



- Insert the spacer bushing in the left bearing "A".
- Assemble the engine connecting pin with the washer "B" and the swinging arm.
- Install the washer and the flanged nut and move them close without tightening.
- Check that the tie rod silent block is free from wear; if not, replace the complete tie rod.
- Check that the 2 tie rod spring pads are in good working order.

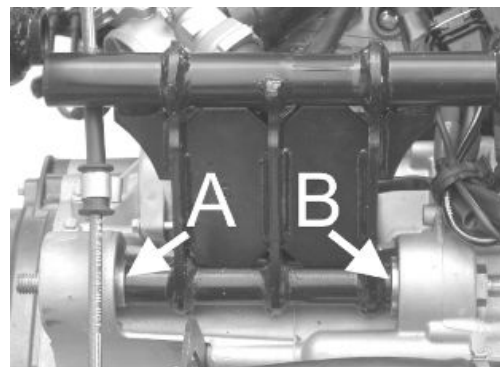

- Assemble the tie rod with the washer and a pad.
- Install the tie rod inserting it on the swinging arm/engine pin and into the bracket welded to the chassis.

**N.B.**

**FOR THIS OPERATION, MOVE THE ENGINE ON THE VEHICLE LONGITUDINAL AXIS.**

**N.B.**

**IF YOU REMOVE THE ELECTRIC SYSTEM SUPPORT BRACKET, REINSTALL IT BEFORE INSERTING THE TIE ROD.**



- Apply the buffer and the washer to the tie rod and lock it.

**Locking torques (N\*m)**

**Upper tie mounting: 33-41 Nm**

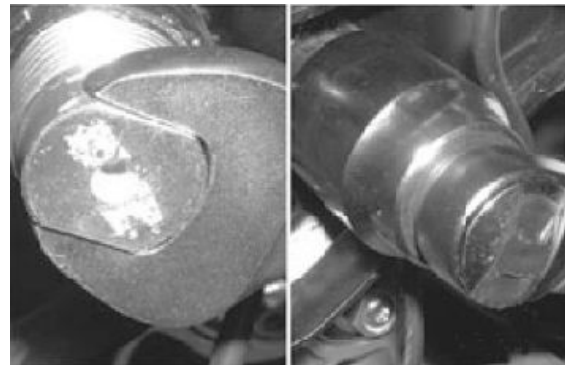

- Lubricate the shaped washer and place it onto the bearing.
- Insert the chassis mounting pin.
- Restore the axial clearance between swinging arm and chassis tightening the pin to the prescribed torque.
- Tighten the lock nut to the prescribed torque.

**Locking torques (N\*m)**

**bolt securing swinging arm to chassis 14 ÷ 17**

**Lock nut 40 ÷ 50**

- Tighten the right end of the chassis connecting pin to the prescribed torque, using a new nut.

**Locking torques (N\*m)**

**RHS chassis pin nut 66 ÷ 73**



- Use a 19-mm fork wrench to prevent the rotation of the pin connecting the swinging arm to the engine and tighten the right nut (with washer) and the left nut to the prescribed torque.



### Locking torques (N\*m)

**Transmission-side nut 100 - 120 Muffler-side nut 56 ÷ 70**

- Heat the connections on the engine crankcase and insert the bearings to abutment using the modular punch.
- To install the right bearing, lower the engine.

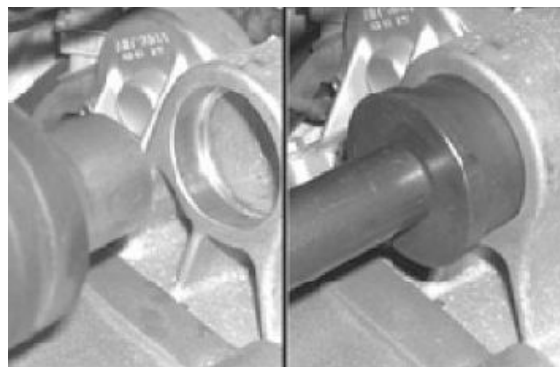

#### N.B.

WHEN HEATING THE LEFT SEAT MOVE THE HOSE FOR OIL TO THE BRAKE CLAMP AWAY FROM THE ENGINE CRANKCASE. FOR THE RIGHT PART REMOVE AND MOVE AWAY THE BRACKET SUPPORTING THE WIRING.

### Specific tooling

020151Y Air heater

020359Y 42x47-mm adaptor

020363Y 20 mm guide

020376Y Adaptor handle

- Insert the spacer on the ball bearing using the special tool.

### Specific tooling

020357Y Adaptor 32 x 35 mm

020362Y 12 mm guide

020376Y Adaptor handle



- Heat the bearing seat on the swinging arm.
- Insert the bearing to abutment using the special tool.

**N.B.**

THE BEARING SPACER MUST BE INSERTED FROM THE INSIDE OF THE SWINGING ARM.

**N.B.**

DO NOT DETERIORATE THE PAINTED SURFACE WHILE WARMING THE SWINGING ARM.

**Specific tooling**

020151Y Air heater

020376Y Adaptor handle

020362Y 12 mm guide

020357Y Adaptor 32 x 35 mm

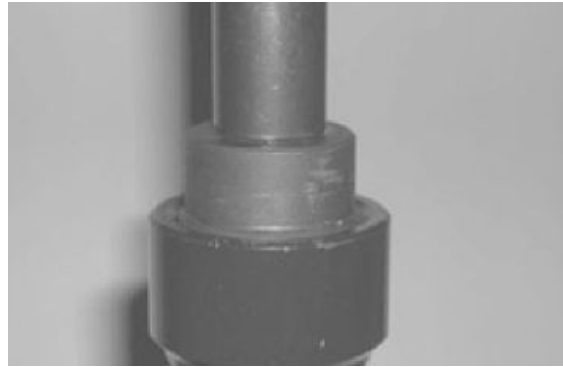

- Install the Seeger ring.

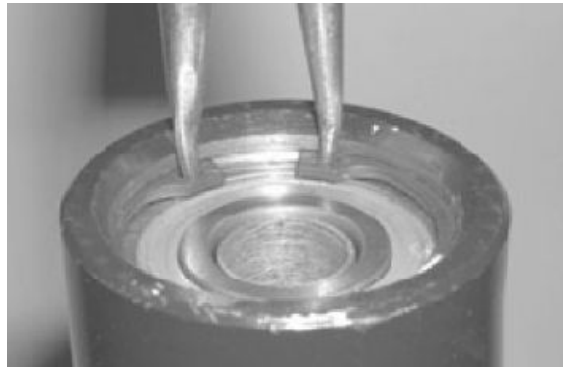

- Install the roller bearing using the special tool.

**Specific tooling**

020083Y Punch

**Shock absorbers****Removal**

Proceed as follows:

- Rest the vehicle on the central stand;
- Remove the sides according to the removal sequence described in Chapter "Body".

- Slightly raise the engine using a jack to free both shock absorbers;
- Remove the muffler;



- Loosen the shock absorber spring unit fastening screw from the support fixed to the engine and from that fixed to the muffler support;



- Loosen the two top nuts (one by side) mounting the shock absorber spring unit to the chassis and remove the shock absorbers.



### See also

[Side fairings](#)

---

## Refitting

Carry out the previous operations but in reverse order.

### Locking torques (N\*m)

**Lower shock absorber clamp 33 ÷ 41 Upper shock absorber clamp 33 ÷ 41**

---



---

**Centre-stand**

---

- Remove the two return springs from the centre stand.
- Loosen the fastening nuts.
- Remove the centre stand.
- On refitting tighten the nut to the specified torque.

**Locking torques (N\*m)****Central stand retainers 25 ± 30**

---

**Side stand**

---

- Release the springs.
- Loosen the nut.
- Extract the screw.

**FITTING**

- For reassembly, perform the previous operations in the reverse order

**Locking torques (N\*m)****Side stand fastening bolt 40 - 45 Nm**

## INDEX OF TOPICS

**B**RAKING SYSTEM

**BRAK** SYS

---

## Rear brake calliper

---

### Removal

- Remove the rear wheel.
- Remove the snap ring of the pad retaining pin.

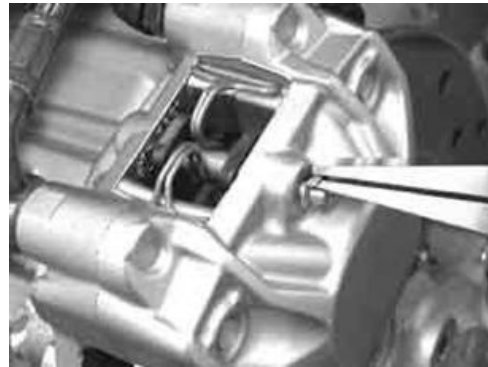

- Using a key, partially slide off the pad retaining pin until the circlip is released.



- Remove the screws fixing the brake calliper to the bracket, then remove the brake calliper complete with pipe.



- Complete the extraction of the pad retention pin, the spring and the pads.

**N.B.**

**IF BRAKE CALLIPER REPLACEMENT OR SERVICE IS NEEDED, BEFORE REMOVING THE CALLIPER CLAMPS TO THE SUPPORT BRACKET, LOOSEN THE OIL JOINT FITTING.**

---

## Overhaul

- Remove the rear brake calliper
- Suitably support the brake calliper in a vice
- Remove the two calliper coupling screws as shown in the photograph.



- Remove the two plungers from the calliper body with the aid of short blasts of compressed air through the brake fluid feed holes.
- Remove the dust ring and the O-ring of each half calliper.
- Remove the two O-rings in the right half-calliper.



**N.B.**

**WHEN REMOVING THE O-RINGS, BE CAREFUL NOT TO SCRATCH THE HALF CALLIPER SEATS**

- Check that the pistons and their seats show no scratches.
- Wash and blow all the components carefully.
- Fit new sealing rings and dust guards.
- Refit the plungers in their seats being careful to lubricate with brake fluid



- Couple the half-calliper and tighten the two screws to the prescribed torque.

**N.B.**

**TO AVOID DAMAGING THE GASKETS, WASH THE PLIERS COMPONENTS ONLY WITH ALCOHOL. DO NOT USE FUEL OR DERIVATIVES.**

### Locking torques (N\*m)

**Brake calliper coupling 20 - 24**

## Refitting

- The rear break calliper can be recognised by its  $\varnothing 34$  mm plungers and the bleed screw as shown in the figure.



- Insert the break pads in the pliers according to the arrow that indicates the break disc direction of rotation as shown in the photograph.



- Insert the pad fixing pin and the retention spring being careful to position its ends pointing towards the bleed screw as shown in the photograph.



- Insert the circlips on the pad fixing pin.

**N.B.**

**FAILURE TO RESPECT THE PAD POSITIONING REQUIREMENTS WITH RESPECT TO THE DIRECTION OF ROTATION COULD COMPROMISE PROPER BRAKE FUNCTIONING AND NOISELESSNESS.**

- Keep the brake pads in contact with the plungers and insert the calliper in the brake disc.
- Fix the calliper to the support with the two screws with spring washer to the prescribed torque as shown in the photograph.

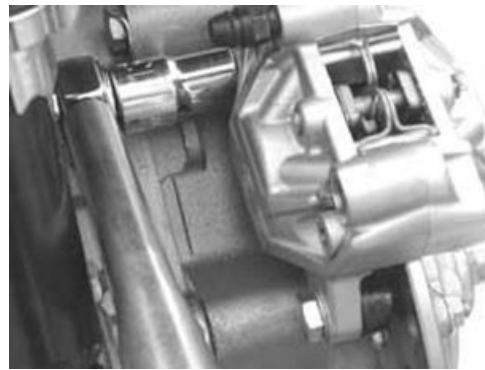

- Fasten the brake pipe union to the calliper and tighten to the prescribed torque
- Bleed the system and replace the rear wheel

**N.B.**

**IF THE REAR BREAK CALLIPER SUPPORT PLATE HAS BEEN REMOVED, UPON REFITTING IT IS NECESSARY TO FOLD THE EDGES OF THE WASHER ON THE HEAD OF THE SCREWS FIXING THE PLATE TO THE CRANKCASE.**

### Locking torques (N\*m)

Pipe / brake calliper coupling 20 ÷ 25 Rear calliper support on crankcase retainer 20 ÷ 25

## Front brake calliper

### Removal

- Remove the two front break calliper retainers to the support plate as shown in the photograph



**N.B.**

**WHEN A PROCEDURE IS PLANNED INCLUDING THE SERVICE OR REPLACEMENT OF THE CALLIPER, FIRST LOOSEN THE FITTING CONNECTING THE PIPE TO THE BRAKE CALLIPER**

### Overhaul

- Remove the rear brake calliper.
- Suitably support the brake calliper in a vice
- Remove the two calliper coupling screws as shown in the photograph
- Remove the two plungers from the calliper body with the aid of short blasts of



compressed air through the brake fluid feed holes

- Remove the dust guard and the sealing ring of each half-calliper.
- Remove the two sealing rings in the right half-calliper.

**N.B.**

**WHEN REMOVING THE O-RINGS, BE CAREFUL NOT TO SCRATCH THE HALF CALLIPER SEATS**

- Check that the pistons and relevant seats exhibit no scratches.
- Wash and carefully blow all components.
- Fit new sealing rings and dust guards.
- Replace the pistons into their seats and lubricate with brake fluid.
- Couple the half-calliper and tighten the two screws to the prescribed torque.



**Locking torques (N\*m)**

**Calliper coupling screws: 20-25 N\*m**



**Refitting**

- The front left brake calliper is recognisable by the pistons diameter 32 mm whereas the front right calliper is recognisable by the pistons diameter 34 mm
- Fasten the calliper to the support bracket using the two screws with spring washer to the prescribed torque, as shown in the figure
- Fasten the brake pipe union to the calliper and tighten to the prescribed tor-



que, orientating the union parallel to the horizontal axis, as shown in the figure

### Locking torques (N\*m)

**Brake calliper fastening screws: 20-25 N\*m**  
**Brake coolant pipe union 20-25 N\*m**



## Rear brake disc

### Removal

- Remove the rear brake calliper
- Remove the brake disc with hub from the wheel axle.
- To remove the brake disc from the hub, support the unit in a vice and tighten the 5 fastening bolts with self-locking nuts.

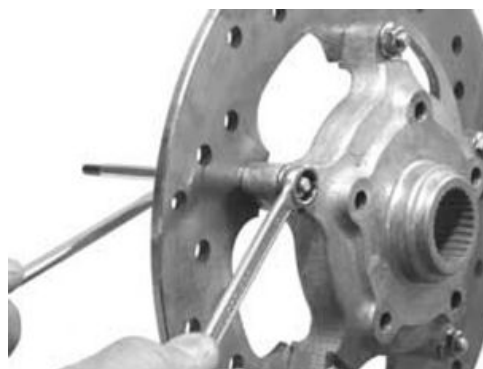

### Refitting

- To reassemble the brake disc on the hub, carry out the removal operations in the reverse order arranging the brake disc on the hub on the side opposed the wheel keying
- Follow the direction of rotation shown by the arrow and tighten to the prescribed torque.
- Lubricate the seat of the wheel bearing shaft on the manifold support with the recommended grease.

**N.B.**

**APPLYING AN EXCESSIVE QUANTITY OF GREASE MAY IMPAIR THE BRAKE PERFORMANCE**

### Recommended products

**AGIP GREASE PV2 Grease for the steering bearings, pin seats and swinging arm**





White anhydrous-calcium based grease to protect roller bearings; temperature range between -20 C and +120 C; NLGI 2; ISO-L-XBCIB2.

- Insert the hub - disc assembly in the wheel axle.

### Locking torques (N\*m)

Rear brake disc mounting 11 ÷ 13

## Disc Inspection

- Remove the rear brake calliper.
- Use the micrometer to check the thickness of the disc as shown in the photograph



### Characteristic

#### Standard thickness:

5 +0.2-0.1 mm

- Repeat the measurement in at least 6 points on the disc
- Check that the measurement does not deviate over 0.1 mm
- Check that the brake disc assembly rotates smoothly using the appropriate tool fixed onto the brake calliper as shown in the photograph.
- Suitably fix the flange to the wheel axle with the original nut and spacer and a  $\varnothing$  17 mm bearing



#### N.B.

SO AS NOT TO GET A DISTORTED READING, CAUSE THE DRIVEN PULLEY SHAFT TO TURN IN ORDER TO ROTATE THE DISC.

### Specific tooling

020335Y Magnetic support for dial gauge

### Characteristic

#### Max. deviation allowed:

0.1 mm

- If incorrect values are detected, replace the disc. If the problem persists, replace the hub.

---

## Front brake disc

---

### Removal

---

- Remove the front wheel.
- Adequately support the front wheel and remove the brake disc operating on the five screws shown in the photograph.



---

### Refitting

---

- Perform the removal operations in the reverse order according to the direction of rotation of the disc, as shown by the arrow on the disc.
- Tighten the 5 screws to the prescribed torque.



#### Locking torques (N\*m)

Brake disc tightening torque 11-13 Nm

---

### Disc Inspection

---

- Use the micrometer to check the thickness of the disc as shown in the photograph

#### Characteristic

Standard thickness:

4 +02-01mm



- Repeat the measurement in at least 6 points on the disc
- Check that the measurement does not deviate over 0.1 mm
- Remove the front brake calliper
- Place the magnetic base with the dial gauge on the break calliper support bracket as shown in the photograph
- Place the dial gauge on the disc outer edge
- Lift the front wheel, make it turn and check the disc deviation



### Specific tooling

**020335Y Magnetic support for dial gauge**

### Characteristic

**Max. deviation allowed:**

0.1 mm

---

## Front brake pads

---

### Removal

- Remove the front brake calliper
- Remove the circlip of the pad retaining pin as shown in the photograph
- Using a key remove the pad retaining pin, then remove the break pads
- Check that the pads show no flaws or warping. If there is, replace it.
- Check that the thickness of the friction material is over 1.5 mm. Otherwise, replace it



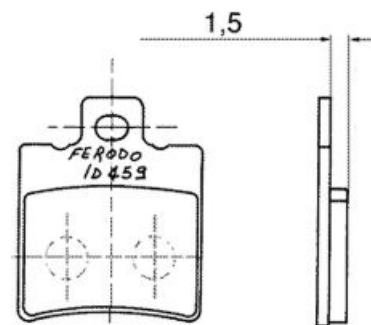
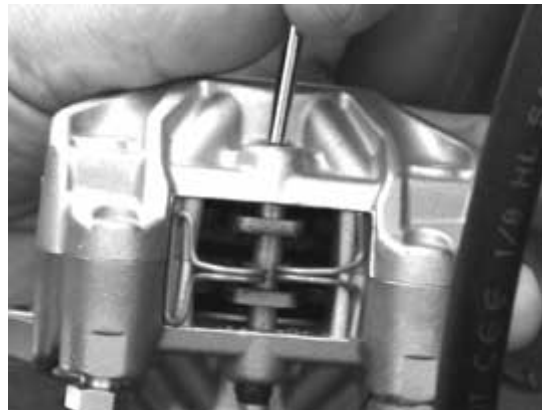

## Refitting

- Insert the break pad in the calliper as shown in the photograph
- Insert the pad fixing pin and the retention spring being careful to position its ends pointing towards the bleed screw as shown in the photograph
- Insert the circlips on the break pad fixing pin
- Keep the brake pad in contact with the plungers and insert the calliper in the brake disc.



---

## Rear brake pads

---

### Removal

---

- Remove the rear brake calliper
- Remove the brake pad and check there are no faults or warping. If it does, replace it.
- Check that the thickness of the friction material is over 1.5 mm. Otherwise, replace it.

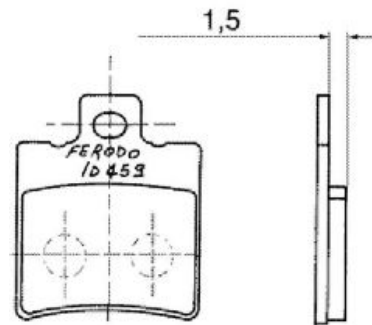

---

### Refitting

---

- Insert the brake pads according to the direction of rotation of the brake disc, as indicated by the arrow on the anti-vibration pad.
- Insert the pad mounting pin and the retain spring with its ends facing the bleed screw as shown in the figure.
- Insert the retaining ring on the pin
- Fasten the rear brake calliper to the bracket and tighten the 2 screws to the prescribed torque.

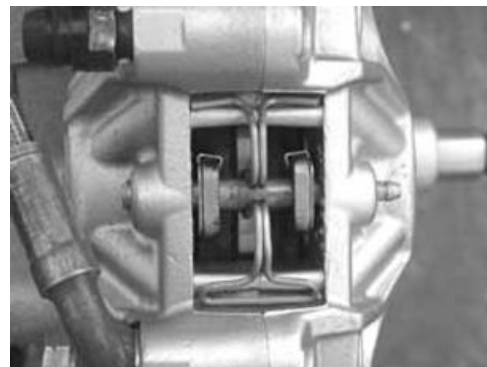
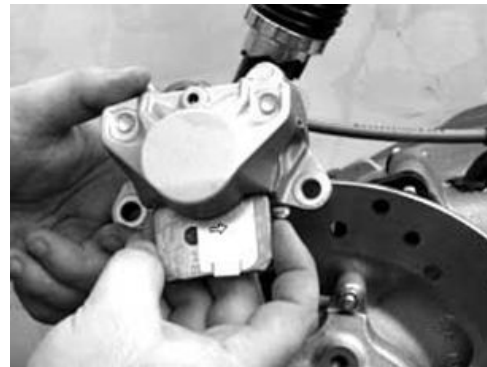

#### Locking torques (N\*m)

Rear brake calliper fixing screws 20 ÷ 25

---

### Fill

---

## Rear - combined

To bleed the integral system, first bleed the rear break calliper.

- Remove the rubber cap from the bleed screw and insert a rubber pipe to recover the brake fluid.



- With the left-hand brake lever, load the system and bring it up to the required pressure.

- Keeping the left-hand brake lever pulled, loosen the bleed screw to purge the air. Then tighten the bleed screw.



- Repeat the operation until only brake fluid comes out of the rubber pipe.

- Then repeat the bleed operations for both the regulating valve and the front left calliper.



- To access the regulating valve, it is necessary to remove the front shield.

- Top up the brake fluid to the right level in the tank.

### N.B.

**DURING THE BLEEDING OPERATIONS, MAKE SURE THE BRAKE FLUID DOES NOT COME INTO CONTACT WITH THE BODYWORK SO AS NOT TO DAMAGE IT. FURTHERMORE, DURING THE BLEEDING OPERATIONS REGARDING THE BRAKE CALLIPERS, MAKE SURE THE BRAKE FLUID DOES NOT COME INTO CONTACT WITH THE DISC BRAKES AND WITH THE BRAKE PADS. FAILURE TO COMPLY WITH THIS NORM WILL ENDANGER THE PROPER WORKING AND EFFICIENCY OF THE BRAKING SYSTEM**

If necessary, bleeding can be done using a special vacuum pump

### Specific tooling

**020329Y MityVac vacuum-operated pump**

### Locking torques (N\*m)

---

**Circuit bleed calliper fitting 12 - 16**

---

**Front**

- Remove the rubber hood from the bleed screw.
- Insert a rubber pipe in the bleed screw to permit the brake fluid to be recovered.



- With the right-hand brake lever, load the system and bring it up to the required pressure.
- Keeping the right-hand brake lever pulled, loosen the bleed screw to purge the air. Then tighten the bleed screw.
- Repeat the operation until only brake fluid comes out of the rubber pipe.
- Remove the fluid recovery pipe and refit the rubber cap over the bleed screw.
- Top up the brake fluid to the right level in the reservoir.

**N.B.**

**DURING THE BLEEDING OPERATIONS, MAKE SURE THE BRAKE FLUID DOES NOT COME INTO CONTACT WITH THE BODYWORK SO AS NOT TO DAMAGE IT. FURTHERMORE, DURING THE BLEEDING OPERATIONS REGARDING THE BRAKE CALLIPERS, MAKE SURE THE BRAKE FLUID DOES NOT COME INTO CONTACT WITH THE DISC BRAKES AND WITH THE BRAKE PADS. FAILURE TO COMPLY WITH THIS NORM WILL ENDANGER THE PROPER WORKING AND EFFICIENCY OF THE BRAKING SYSTEM**

If necessary, bleeding can be done using a special vacuum pump

**Specific tooling**

020329Y MityVac vacuum-operated pump

**Locking torques (N\*m)**

Circuit bleed calliper fitting 12 - 16

---

**Brake fluid level check****Top up**

---

**CAUTION**

**ONLY USE DOT 4-CLASSIFIED BRAKE FLUID.**

---

Proceed as follows:

- Rest the scooter on a flat ground and on the centre stand.
- - Remove the brake pump cover as shown in the figure.
- Remove the tank cap by loosening its two screws indicated in figure remove the gasket and top up the level, using only the prescribed fluid without exceeding the maximum level.



#### CAUTION



AVOID CONTACT OF THE BRAKE FLUID WITH YOUR EYES, SKIN, AND CLOTHING. IN CASE OF ACCIDENTAL CONTACT, WASH WITH WATER.

#### WARNING

BRAKE CIRCUIT FLUID IS VERY CORROSIVE; DO NOT LET IT COME INTO CONTACT WITH PAINTED PARTS.

#### Recommended products

**AGIP BRAKE 4 Brake fluid**

FMVSS DOT 4 Synthetic fluid



- Rest the scooter on a flat ground and on the central stand.
- Remove the brake pump cover as shown in the figure



- Check the fluid level by the portholes on the pumps.

**N.B.**

THE LEVEL TENDS TO DROP AS THE BRAKE PADS GET WORN, A MINIMUM LEVEL SHOULD NOT BE REACHED. IF THE LEVEL IS TOO LOW, CHECK AND FIX THE SYSTEM SEALS, IF REQUIRED. TOP UP THE PUMP TANK, IF REQUIRED, CONSIDERING THAT THE "MAX." LEVEL MUST ONLY BE OBTAINED WITH NEW PADS.



For re-assembly, perform the operations for removal in the reverse order according to the tightening torque of the tank cover screws.

## Front brake pump

### Removal

- Remove the front handlebar cover
- Remove the two screws mounting the brake pump to the handlebar, as shown in the figure.



- Remove the oil pipe fitting from the pump undoing the screw indicated in the figure.
- Remove the stop light switch connector



### **BRAKE PUMP TECHNICAL DATA**

Specification	Desc./Quantity
Pump right piston diameter:	Ø 12
Pump left piston diameter:	Ø 14

### Refitting

To refit, carry out the removal operations but in reverse order, observing the specified torques.

**Locking torques (N\*m)**

Handlebar pump 7 ÷ 10 Oil pipe joint to the pump: 20 - 25

---

## INDEX OF TOPICS

COOLING SYSTEM

COOL SYS

---

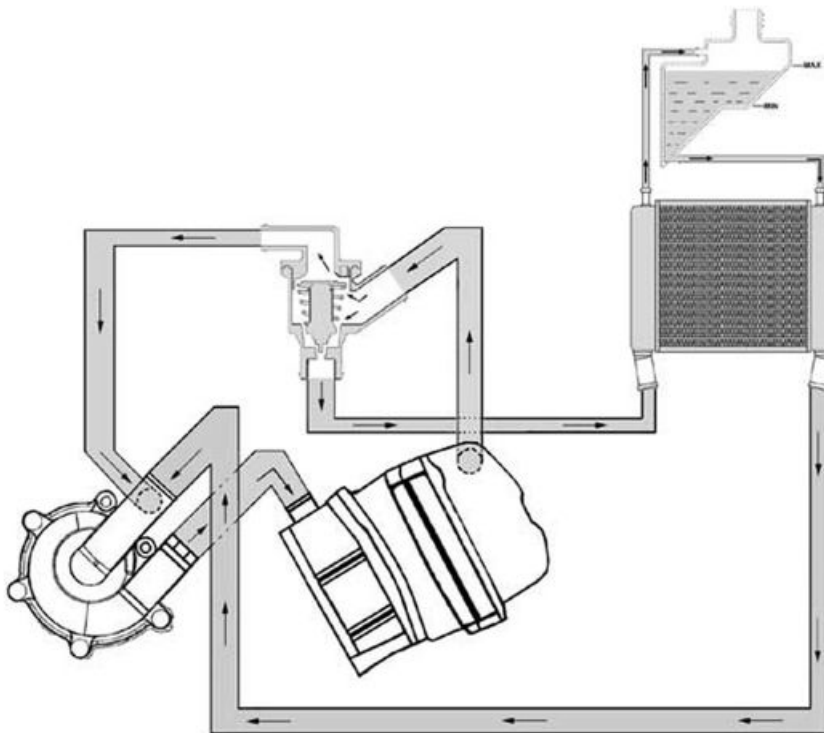
**Circuit diagram**

The cooling system is a forced circulation type system, with continuous venting and air pressurisation. Circulation takes place by a centrifugal pump driven by the countershaft.

The pump delivers the coolant to the thermal group.

The two-way thermostat support is connected in output to the head. One way is connected to the pump and the other to the radiator (of the horizontal circulation type).

The radiator output is directly connected to the pump.

The expansion tank is connected in parallel to the radiator.

The radiator hot box is connected to the upper side of the expansion tank (in air).

The radiator cold box is connected to the lower side of the expansion tank (in the fluid).

When the engine is cold, the thermostat output to the radiator is closed, even though there is still a little flow for de-aeration obtained by a hole into the closing plate.

In this case, the circulation into the thermal group is active to ensure an even heating.

Once the working temperature has been reached, the main circulation on radiator and expansion tank starts.

With the small openings in the thermostat there is a flow overlapping (recirculation and main one).

When the temperature is higher, the thermostat allows excluding the recirculation to favour the main circulation.

In this case, the flow is consistent in the expansion tank as well, and this ensures a continuous automatic venting.

For the system venting during the circuit filling step, there is a special union at the top of the head (see filling rules).

To ensure cooling in case of poor dynamic ventilation, there is an electric fan controlled by the injection system.

### TECHNICAL SPECIFICATIONS

Specification	Desc./Quantity
Cooling system capacity	1.7 l
Prescribed fluid	Mixture of 50% water and fluid for sealed circuits (PARAFLU MOTO RIDER)
Sealing pressure	Cap calibrated at 0.9 bar

### THERMOSTAT

Specification	Desc./Quantity
Type	Wax-type, with deviator
Starts opening	82 ± 2°C

### ELECTRIC VENTILATION

Specification	Desc./Quantity
Type	With piston
Electric ventilation starts at	107°C
Electric ventilation stops at	103°C

### WATER PUMP

Specification	Desc./Quantity
Type	Centrifugal
Control	Coaxial at the countershaft

### RADIATOR

Specification	Desc./Quantity
Type	Aluminium, with horizontal circulation

### EXPANSION TANK

Specification	Desc./Quantity
Calibration	Automatic bleeding, in parallel with the radiator

## Electric fan check

- Connect the injection diagnostic tester and select the «ERRORS» function in this menu.
- Check any failures in the electric fan control circuit (see «Injection»chapter)

### Specific tooling

**020460Y Scooter diagnosis and tester**



- Select the menu on the "ACTIVE DIAGNOSIS" function and start the electric fan operation simulation (see "Injection" chapter).
- If the electric fan is certainly efficient, check the ventilation start and stop temperatures.



- Select the «PARAMETERS» function in this menu to display the coolant temperature.
- If non-conforming values are detected, replace the injection control unit (see "Injection" chapter).
- If the analogue instrument temperature is close to the red zone, but the degrees indicated by the diagnostic tester is below the electric ventilation temperature, check the temperature sensor on the head and the relevant injection circuit (see Injection chapter);

**N.B.**

THE ELECTRIC VENTILATION TEMPERATURE AT 106° C CAN ONLY BE MANAGED WITH A SYSTEM SUPPLIED WITH A 50% MIXTURE AND PRESSURISED AT 0.9 BAR.

**Characteristic****Electric fan start**

106°C

**Electric fan stop**

98°C

- Avoid starting the engine without pressurisation since it may reach the boiling temperature before the electric ventilation starts.
- In case of increase of the electric ventilation time, check the thermostat opening temperature and check that the coolant density is correct. The optimum density is obtained with a 50% water and cooling circuit fluid mixture.

## System sealing check

- Check the proper circuit sealing when it is under pressure and at the temperature.
- For a more accurate check, wait until the system has cooled down since small leaks may not be visible due to evaporation
- The water pump is provided with a drainage hole in case of leaks from the cooling system mechanical seal, or from the shaft sealing oil guard.
- If coolant or oil leaks are detected, inspect the pump (see Flywheel cover chapter).

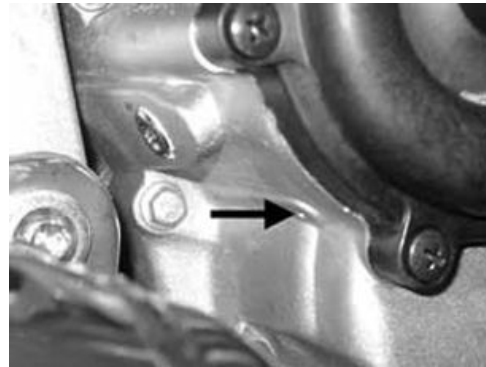

### N.B.

**DO NOT USE OILS OR GREASES WHILE MOUNTING THE COOLING SYSTEM. FAILURE TO OBSERVE THIS REGULATION CAN CAUSE IRREVERSIBLE DEFORMATION TO THE SEALING GASKETS.**

## Coolant replacement

### System top-up instructions

- Prepare the mixture of 50% water and 50% coolant.
- Fill the system to reach a level ranging between the MIX and MAX levels indicated in the expansion tank filler.
- Do not close the expansion tank with the cap.

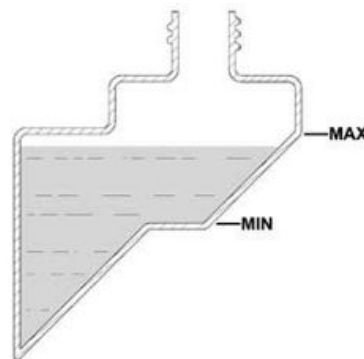

- Use a transparent hose to connect the venting union with the expansion tank filler.
- Loosen the vent and start the engine.

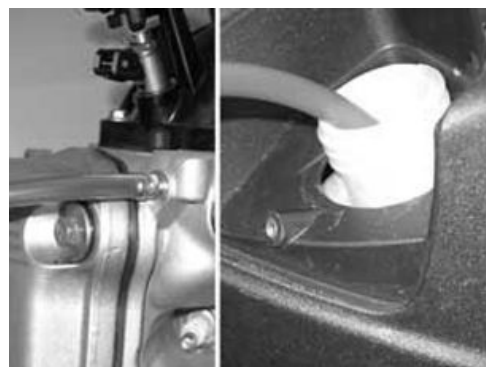

- Keep it open until the air has been fully vented.
- Close the bleed screw.
- Stop the engine.
- Restore the level into the expansion tank and tighten the cap.
- Start the engine and let it warm up to reach the electric ventilation temperature.
- Stop the engine.

- Restore the level with cold engine.

**CAUTION**

**ELECTRIC VENTILATION IS CONTROLLED BY THE TEMPERATURE MEASURED AT THE HEAD. THE ELECTRIC VENTILATION START DOES NOT MEAN THAT THE VENTING HAS BEEN COMPLETED.**

**VENTING IS COMPLETE WHEN THE EXPANSION TANK TEMPERATURE RISES.**

## Water pump - overhaul

In case of noise or fluid leaks from the water pump drainage hole, inspect the pump as described in the "Flywheel cover" chapter.

Proceed to carry out a few preliminary operations as described below:

- Place the vehicle on its centre stand and on flat ground.
- Remove the right footrest as described in the "Body" chapter.
- Remove the muffler to access the flywheel cover, as described in the "Engine" chapter.
- Empty the cooling system, removing the hoses located on the water pump cover and the loading cap located on the expansion tank.

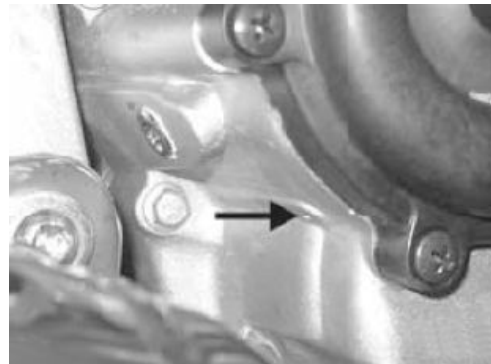

**CAUTION**



**THIS OPERATION MUST BE CARRIED OUT WHEN THE ENGINE IS COLD.**

- Remove the water pump cover shown in the figure by loosening the 6 fastening screws.
- Follow the instructions provided in the "Engine" chapter to partly discharge the system and to inspect the pump.
- Once the fault has been fixed and all components have been replaced, fill and purge the system again.



**N.B.**

**FOR CHANGING THE COOLANT AND BLEEDING THE SYSTEM, SEE CHAPTER "COOLING SYSTEM".**



**Characteristic****Cooling system**

approx. 1.7 litres

**Water pump ceramic seal**

Our Leader, Quasar, and Master liquid cooled engines are equipped with water pumps fitted with the ceramic seal in the subject. This component is intended to guarantee the leak tightness of the coolant in relation to the pump shaft. The seal achieved via two special ceramics, a static one and a spinning one, kept in contact by the thrust of a spring, coaxially mounted onto the pump shaft. The efficiency of this system is guaranteed by the accurate machining and cleaning of the components as they are fitted; in any case, ceramic seals are subjected to a running in period. During this period (1,000 ± 1,500 km), there may be small leaks through draining holes, which remain visible on the aluminium crankcase. This phenomenon is particularly visible there where the hole is more exposed (Quasar and Master). In such cases we recommend cleaning the casing in order to be able to check again for leaks after a distance of more than 1500 km. If leaks continue or in the event of real losses, the ceramic seal should be replaced. For these operations, observe the tools and instructions given in the relevant service station manuals.

Note: The ceramic seal may be overhauled according to the following couplings:

- Coupling "A": seal ring no. 485084 with ceramic seal no. 486216
- Coupling "B": seal ring no. 841329 with ceramic seal no. 841330

The couplings above may be selected according to their availability, as they are interchangeable.

**See also**

[Flywheel cover](#)

[Engine](#)

---

**Thermostat**

---

**Check**

---

Before proceeding to disassembly, carry out a few checks:

- Connect the diagnostic tester and select the "PARAMETERS" function (see "Injection" chapter);
- Start the cold engine and let it warm up.
- Make sure that there is a sudden increase of temperature.

**N.B.**

**THERE SHOULD BE A SLIGHT AND GRADUAL HEATING CAUSED BY A SMALL PASSAGE ON THE THERMOSTAT TO THE OFF POSITION.**

## Specific tooling

### 020460Y Scooter diagnosis and tester

- Check the temperature read by the diagnostic tester.
- If opening occurs at different temperatures, check the thermostat.
- Remove the thermostat as described in the flywheel cover paragraph.

## Characteristic

### Thermostat opening start

approx.  $82 \pm 2^\circ\text{C}$

- Visually check that the thermostat exhibits no mechanical faults.
- Prepare a metal container with approx. 1 litre of water.
- Immerse the thermostat, and keep it in the centre of the container.
- Immerse the multimeter thermometer probe close to the thermostat.
- Heat up the container using the thermal gun.
- Heat the water and periodically pull the thermostat out until its opening becomes visible.
- Insert a thin copper wire between the seat and the thermostat closing plate.
- Keep the wire into position until locking up is perceived.
- Let water and thermostat cool down.
- Progressively heat the water keeping the thermostat immersed by the wire.
- Check the opening temperature when the thermostat releases from the wire.



## Specific tooling

### 020331Y Digital multimeter

### 020151Y Air heater

- Heat to obtain the thermostat full opening
- If incorrect values are detected, replace the thermostat.
- Repeat the filling and venting procedure.

N.B.

**HEATING SHOULD BE GRADUAL.**

**N.B.**

**AVOID CONTACT BETWEEN THERMOSTAT AND CONTAINER FOR A CORRECT TEST PERFORMANCE.**

---

## **diagnosis**

---

### **Excessive system pressure**

1 - Check the expansion tank cap efficiency.

**N.B.**

**THE CAP IS EQUIPPED WITH A PRESSURE RELIEF VALVE CALIBRATED AT 0.9 BAR.**

There is also a valve that must allow air inlet during the cooling step.

YES go to 2 NO go to 3

2 - Check the head gasket seal (see «Thermal group and timing system» chapter)

3 - Replace the cap.

---

### **Cooling fluid consumption**

1 - Check the system outside seals as described above.

YES go to 2 NO go to 3

2 - Check the head gasket seal (see «Thermal group and timing system» chapter)

- If water leaks are detected in the engine oil, inspect the pad on the head cooling circuit.

3 - Fix any damaged seals.

---

### **Oil in the fluid**

1 - Presence of oil in the coolant.

YES go to 2

2 - Check the head gasket seal (see «Thermal group and timing system» chapter)

---

# INDEX OF TOPICS

**CHASSIS**

**CHAS**

---

## Seat

- To remove the saddle, loosen the three screws shown in the figure.



---

## Side fairings

- Remove side bumpers by removing the mounting screws shown in the figure (one on each side).

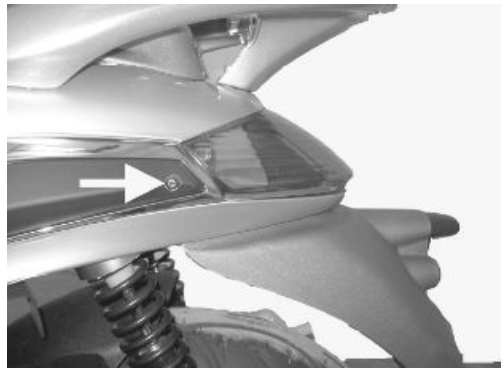

---

## Rear rack

- Loosen the two mounting screws and remove the battery cover.
- Remove the plastic cover of the rear luggage rack by removing the two side screws from the lower side of the rack.
- Loosen the 3 hexagonal retaining screws indicated in the figure and remove luggage rack.



---

## Rear handlebar cover

---

- Remove the brake tank covers by the screw shown in the figure.
- Remove the rear-view mirrors and the windscreen.

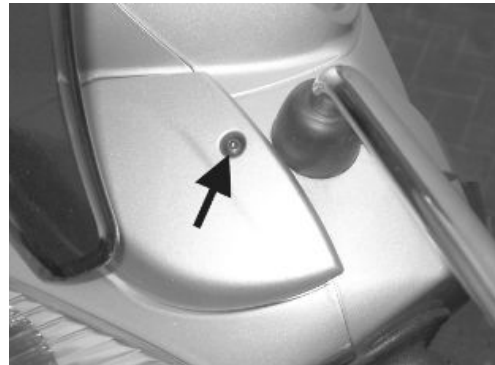

- 
- Remove the upper coupling screws.



- 
- Remove the two lower mounting screws.

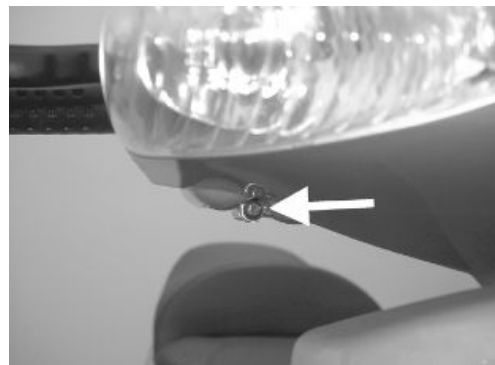

- 
- Remove the two rear handlebar cover screws.
  - Disconnect the electric wiring and remove the rear handlebar cover with instrument unit.

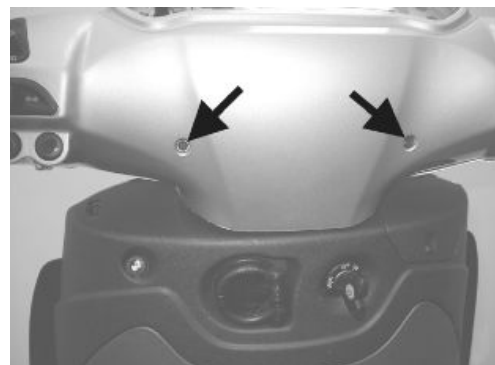

---

## Instrument panel

- Remove the rear handlebar cover.
- Unscrew the four screws shown in the figure to separate the rear handlebar cover from the instrument unit.

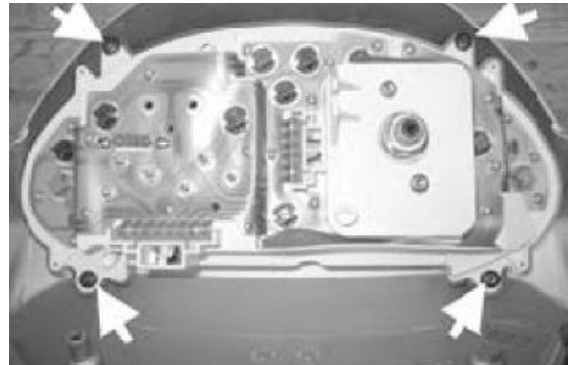

---

## Front handlebar cover

- Remove the rear handlebar cover.
- Unscrew the two mounting screws shown in the figure and remove the front handlebar cover with headlight.

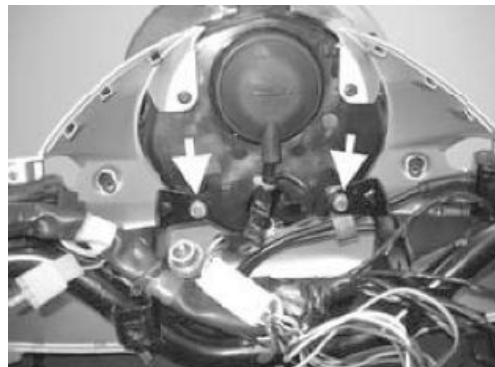

---

## Headlight assy.

- Remove the front handlebar cover.
- Unscrew the three mounting screws shown in the figure to separate the headlight from the front handlebar cover.

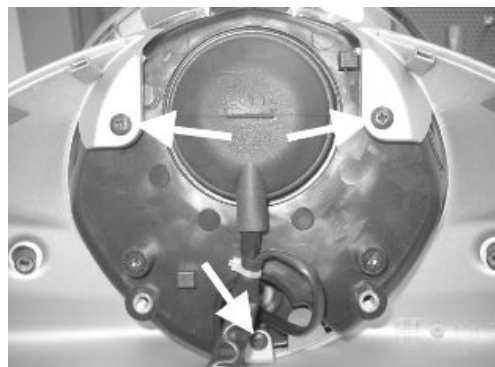

---

## Frame central cover

- Open the fuel tank access port.
- Loosen the 4 screws shown in the figure.
- Temporarily remove the fuel tank cap and the underlying rubber mat.
- Remove the chassis central cover by sliding it from the rear side of the scooter and disconnecting it from the door opening transmission.

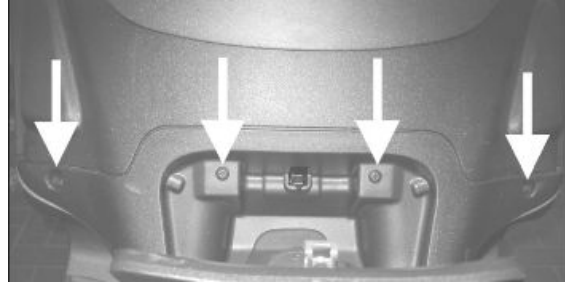

---

## Legshield

- Remove Piaggio badge using a screwdriver being careful not to damage the front shield.

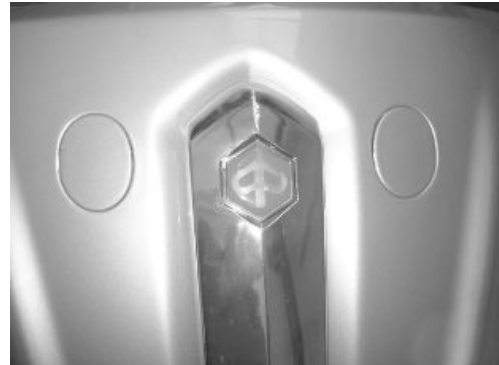

- Remove the screw shown in the figure.



- Remove the two lower fixing screws shown in the figure.

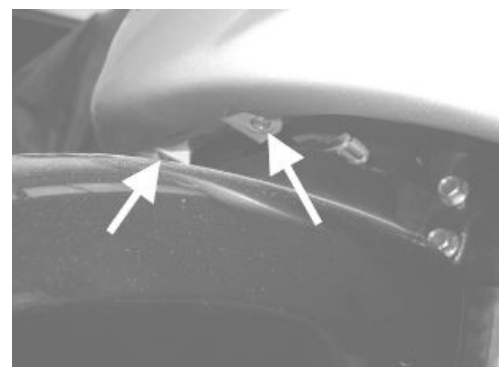



- Remove the expansion tank flap.

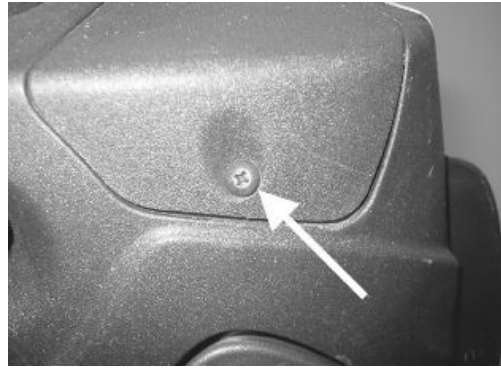

- Remove the fixing screw shown in the figure.



- Remove the central cover.
- Remove the two lower retainers indicated in the figure.
- Remove the whole front shield.



## Knee-guard

- Remove the front shield.
- Disengage the fuse holder rubber cap and loosen the two screws shown in the figure to remove the fuse holder.

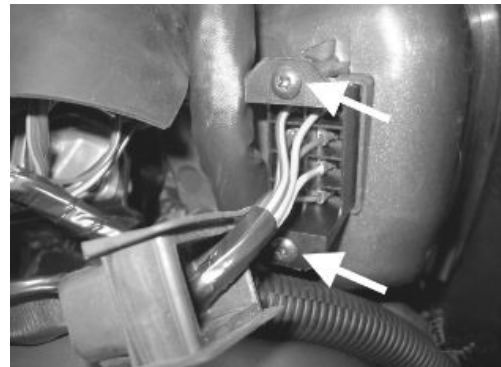

- Disconnect the connectors of the saddle opening button and of the fuel level damper device.



- Remove the expansion tank fixing screw, inside the glove-box.

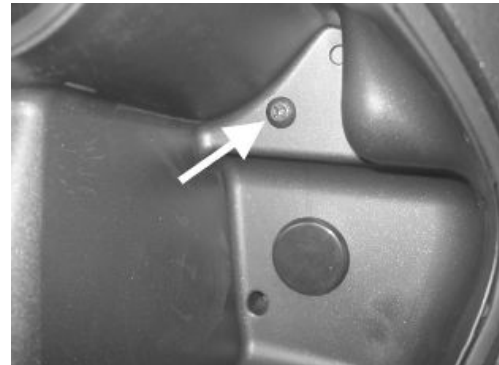

- Remove the shield back plate central fixing screw.



- Remove the two transmissions (saddle opening and fuel tank lid opening).



- Remove the cover and rubber gasket from the expansion tank filler.
- Detach the shield back plate and release the expansion tank filler from the hole on the shield back plate.
- Remove the shield back plate.

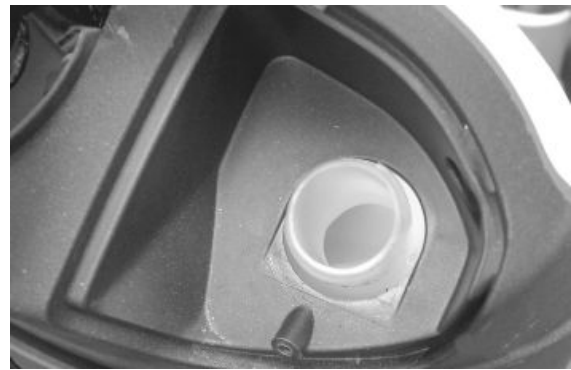

**Removing the ignition key-switch when on \*off\***

- Remove the rear shield.
- Remove the immobilizer aerial shown in the figure.



- Lightly push the master-cylinder and extract the lock from the notch shown in the figure.
- Hence extract the master-cylinder complete with the lock body.



- To refit place the spring on the right side hole.
- Insert the master-cylinder and the lock body and, using a pair of pliers, drive the stop spring until it stops.



## Removing the ignition key-switch when on \*lock\*

In "Lock" and "ON" position, the cylinder locking spring cannot be accessed. Drill the clip as shown in the figure to eject the lock cylinder.

### N.B.

FOR REASSEMBLY FROM THIS POSITION, RELEASE THE STEERING WHEEL AND SET THE LOCK BODY (INSIDE AND OUTSIDE PART) TO "OFF". THEN, PROCEED AS DESCRIBED IN PARAGRAPH REMOVAL, LOCK IN OFF POSITION.

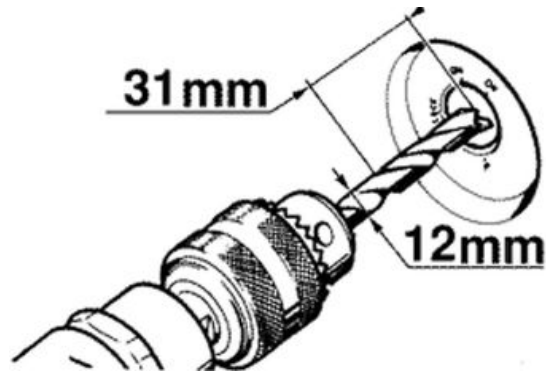

### See also

[Removing the ignition key-switch when on \\*off\\*](#)

## Taillight assy.

- Remove the two side bumpers.
- Remove the two side securing screws from the light unit shown in the figure.



- Remove the plastic cover of the rear trunk rack by removing the two side screws from the lower side of the rack.



- Remove the upper mounting screw through the special hole on the trunk rack.



- Remove the rear light group and disconnect the electric connector.

---

## Footrest

- Remove the central cover.
- Remove the six screws shown in the figure.

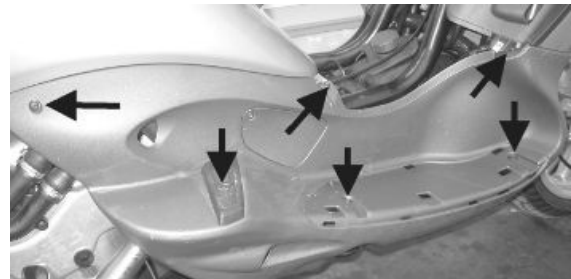

- Remove the three retainers shown in the figure.

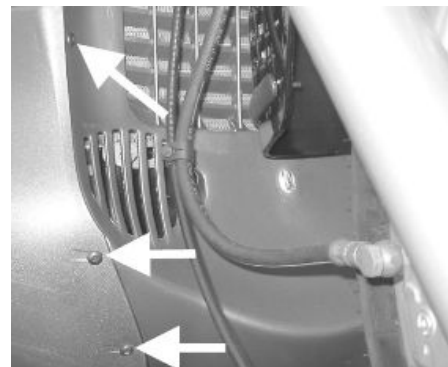

- Remove the diagnosis socket (RHS footrest only) from the side engine inspection port and remove the complete footrest.

## Side fairings

Remove the saddle.

- Remove the under-saddle cover by loosening the mounting screw shown in the figure.
- Remove the central cover.
- Remove the rear light unit.
- - Remove the rear luggage rack.



- Remove the three front side mounting screws shown in the figure.

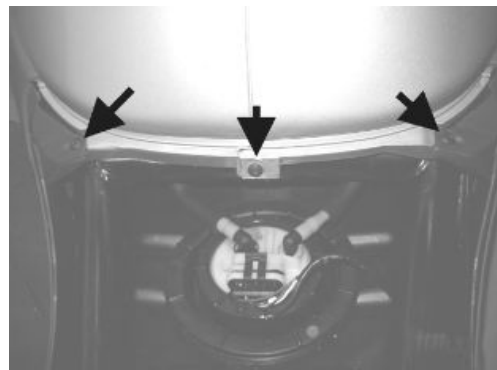

- Remove the rear side mounting screw shown in the figure.



- Remove the screw shown in the figure.



- - Remove the two fairing retaining screws shown in the figure.

**CAUTION**

THE TWO SCREWS SHOWN IN THE FIGURE HAVE DIFFERENT LENGTH. USE THE SHORTER SCREW FOR SIDE MOUNTING SINCE THE LONGER ONE WOULD DAMAGE THE UNDER-SADDLE COMPARTMENT INSIDE WALL.

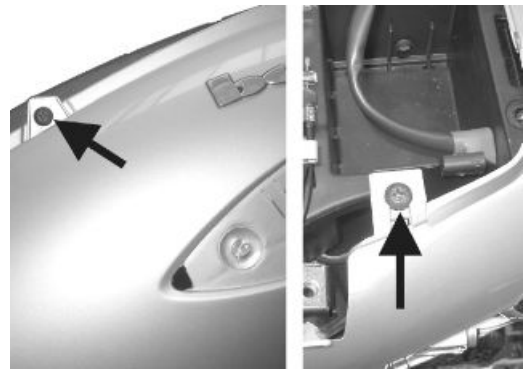

- Remove the plastic parts of the footrests and the sides.

**License plate holder**

- Remove the side panels
- Remove the side retainers from the licence plate holder tail highlighted in the figure.

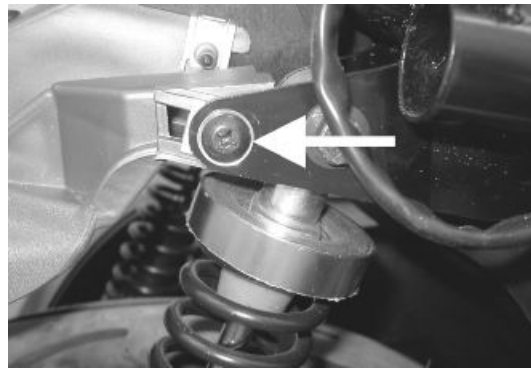

- Remove the two upper retainers highlighted in the figure.

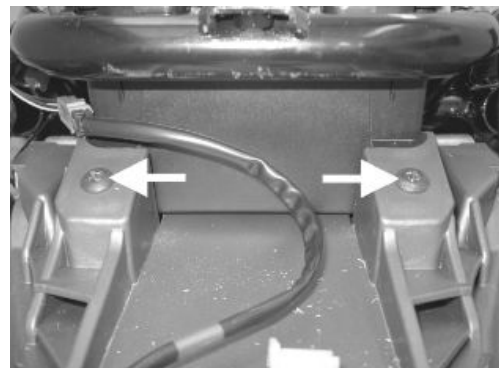

- Remove the two internal retainers to the battery compartment.
- Detach the electrical wiring.
- Remove the whole licence plate holder support.

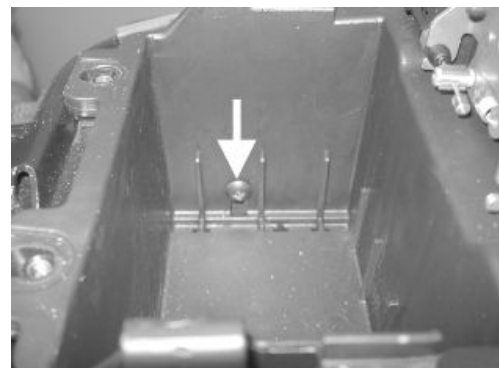

---

## Air filter

- Remove the two mounting screws shown in the figure.

**UPON REASSEMBLY, THE SHORTER SCREW MUST BE INSERTED INTO THE REAR SIDE.**

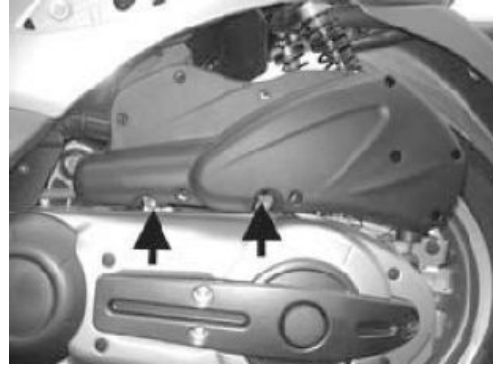

- Remove the blow-by and condensate exhaust pipe cap.
- Loosen the intake hose screw band.
- Loosen the blow-by pipe band.
- Pull out the complete air filter box.

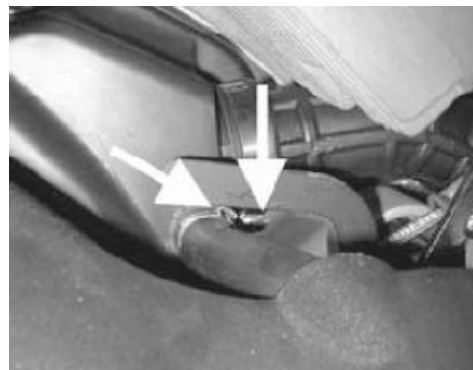

---

## Rear mudguard

- Remove the air filter box.
- Disconnect the rear brake pipe retain strap.
- Remove the two retainers shown in the figure.
- Remove the mudguard from the scooter right side.

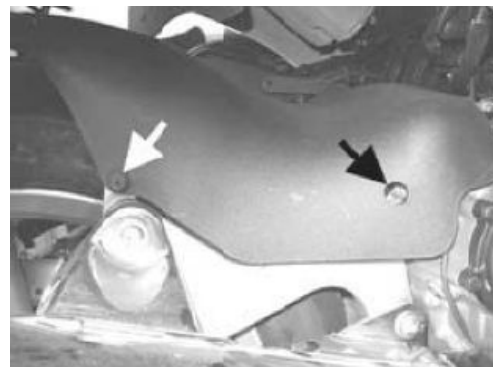



## Helmet bay

- Remove the side panels
- Remove the licence plate holder tail.
- Remove the saddle opening control primary transmission.
- Remove the internal light.
- Remove the saddle light button connections.

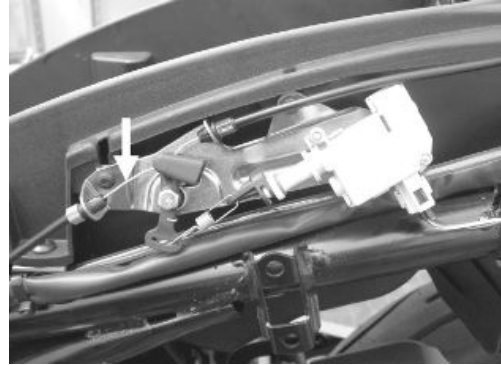

- Remove the current socket connection.
- Remove the start-up remote control switch mounting screw.

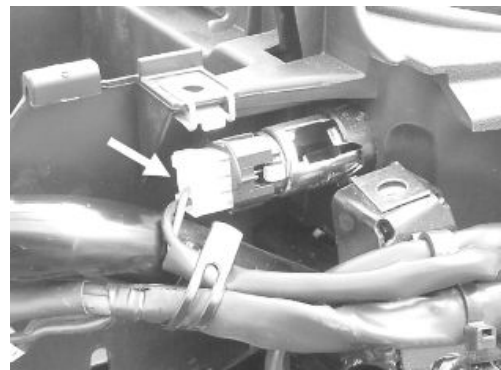

- Disconnect the two connectors (alternated and direct three-phase) of the voltage regulator, remove the chassis / system strap and the cable stop on the three-phase.

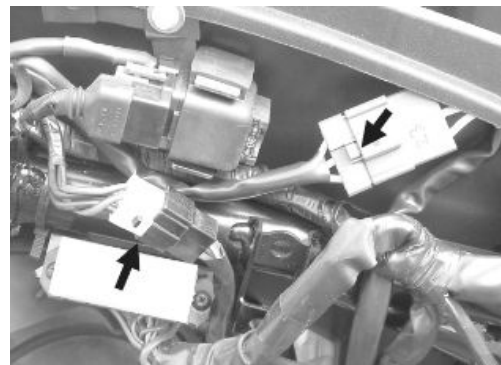

Through the six retainers, remove the helmet compartment with voltage regulator.

## spoiler

- Slide off the front fork together with the wheel and the mudguard.
- Remove the retainers between the footrests indicated in the figure.

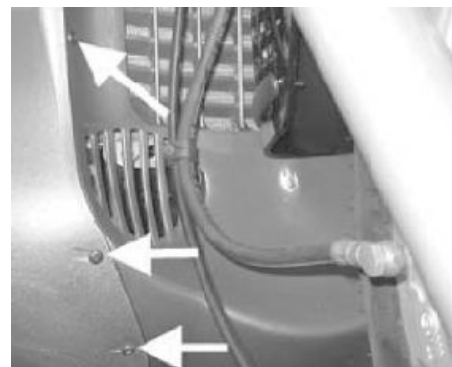

- Remove the upper screw and the two lower screws fixing the spoiler.

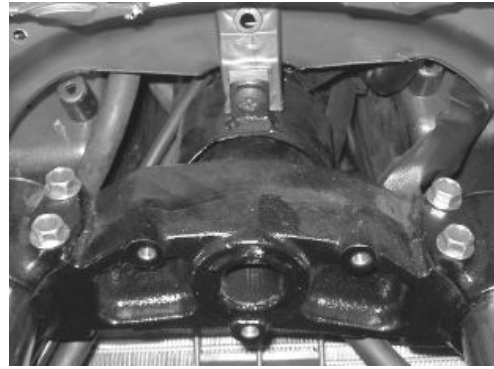

## Fuel tank

- - Remove the front shield.
- Remove the footrest.
- Remove the upper retainer and the two lower retainers of the spoiler.

**N.B.**

**THIS OPERATION SHOULD PREFERABLY BE PERFORMED WITH THE TANK EMPTY.**



- Protect the front mudguard and the radiator to avoid scratching and/or damaging them, then move the spoiler towards the mudguard and turn the handlebars completely to the right or left to gain access to the area under the tank.



- Disconnect the electric connection on the pump and the fuel delivery and inlet piping.

**N.B.**

**BE VERY CAREFUL WHEN PULLING OUT THE CARBU-RETTOR PIPING SINCE AN EXCESSIVE FORCE MAY DAMAGE THE PLASTIC INSERTS ON THE PUMP BODY. UPON REASSEMBLY, IT IS THEREFORE NECESSARY TO SLIGHTLY PRESS THE PIPING AND THE RETAIN RIM TOWARDS THE PUMP, THEN KEEP THE RIM PRESSED AND PULL THE COUPLING UPWARDS.**

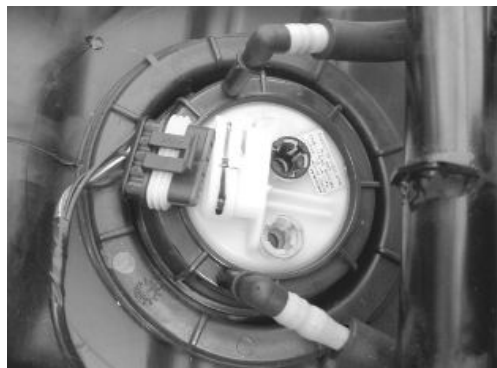

- Remove the two lower chassis cross members: for the front one, which is fixed by 4 screws, it is also necessary to release the coolant delivery and reverse pipes from the clamps placed on the cross member; the rear one is provided with two retainers only.



- Remove the front screw.



- Remove the rear retainer.



- Move the tank backwards and pull out the front side downwards, then release the rear side sideways.

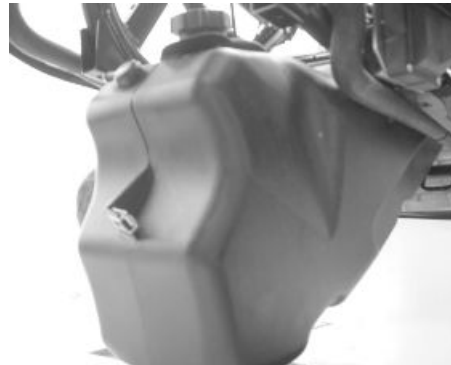

For reassembly, perform the operations in the reverse order, paying attention to the following tightening torques.

### Locking torques (N\*m)

Chassis cross-member lower screws 16 - 25 Chassis front cross member upper screws 6 to 10.5 Nm

### Rear central cover

- Remove the saddle.
- Remove the 2 mounting screws shown in the figure.



## Front mudguard

- - Remove the front wheel
- Remove the retainer «A» from the odometer transmission to the mudguard and from the fork leg right cover.
- Remove the retainer «B» from the right front break pipes.

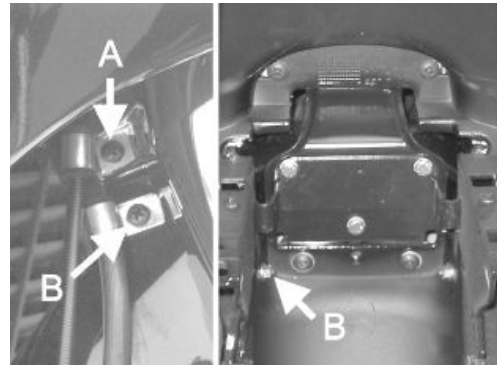

- Remove the retainer «C» from the fork leg left cover.
- Remove the retainer «D» from the left front break pipes.

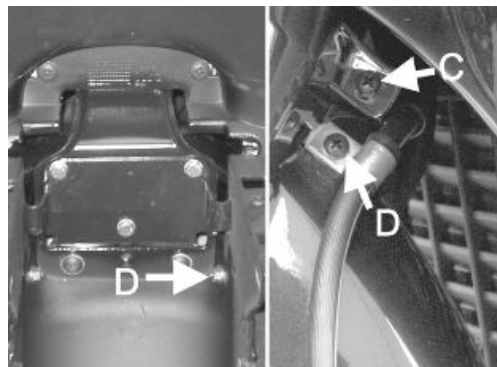

- Remove the two lower retainers «E» from the fork leg covers.
- Remove the three retainers «F».

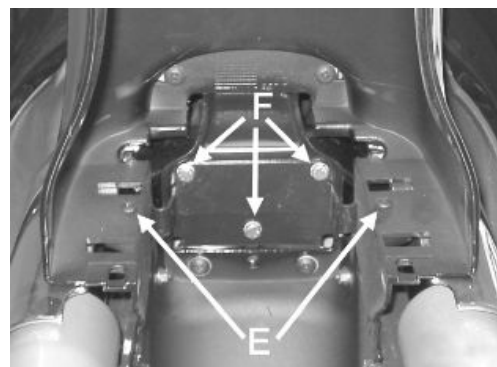

- Lower the mudguard and remove the retainer «G» from the left front break pipes.
- Remove the mudguard together with the plate.

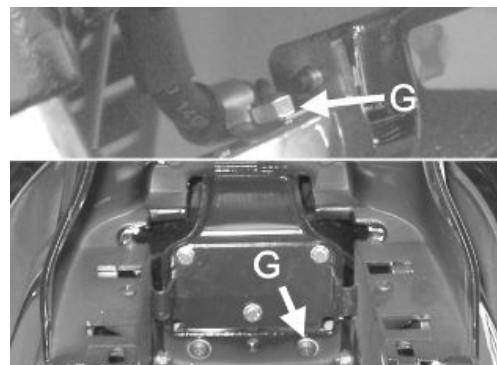

## Radiator fan

---

- Remove the front wheel housing.
- Prepare a container for the coolant.
- Remove the expansion tank outlet and return pipes.
- Remove the coolant supply and return pipes from the radiator.
- Loosen the screw mounting the radiator to the frame.
- Disengage the radiator and the electric fan.



## INDEX OF TOPICS

**P**RE-DELIVERY

**P**RE DE

Carry out the listed tests before delivering the vehicle.

**WARNING**

**BE VERY CAREFUL WHEN HANDLING FUEL.**

## Aesthetic inspection

**Appearance check:**

- Paintwork
- Fitting of plastics
- Scratches
- Dirt

## Tightening torques inspection

**Lock check**

- Safety locks

**SAFETY LOCKS:**

Name	Torque in Nm
Rear shock absorber retainer to the chassis	38 - 46
Front wheel axle	45 ÷ 50
Rear wheel axle	104 ÷ 126
Rear brake disc mounting	11 ÷ 13
Engine - chassis fixing pin	100 - 120
Fixing screw handlebar to steering tube	45 ÷ 50
Upper steering ring nut	36 - 39
Steering lower ring nut	10 - 13 **

\*\* *tighten and loosen by 90°*

- Cover retaining screws

## Electrical system

**Electrical System:**

- Main switch
- Headlamps: high beams, low beams, side/taillights (front and rear) and relevant warning lights
- Adjusting the headlights according to the regulations currently in force
- Front and rear stop light buttons and bulb
- Turn indicators and their warning lights
- Instrument lighting
- Instrument panel: fuel and temperature indicator
- Instrument panel warning lights
- Horn
- Electric start-up
- Engine stop by emergency stop switch and side stand
- Saddle electric opening button



**CAUTION**

**TO ENSURE MAXIMUM PERFORMANCE, THE BATTERY MUST BE CHARGED BEFORE USE. INADEQUATE CHARGING OF THE BATTERY WITH A LOW LEVEL OF ELECTROLYTE BEFORE IT IS FIRST USED SHORTENS BATTERY LIFE.**

**CAUTION**

**WHEN INSTALLING THE BATTERY, CONNECT THE POSITIVE CABLE BEFORE CONNECTING THE NEGATIVE ONE, AND PERFORM THE REVERSE OPERATION UPON REMOVAL.**

**WARNING**

**BATTERY ELECTROLYTE IS TOXIC AND IT MAY CAUSE SERIOUS BURNS. IT CONTAINS SULPHURIC ACID. AVOID CONTACT WITH EYES, SKIN AND CLOTHING.**

**IN CASE OF CONTACT WITH EYES OR SKIN, RINSE WITH ABUNDANT WATER FOR ABOUT 15 MINUTES AND SEEK MEDICAL ATTENTION AT ONCE.**

**IF IT IS SWALLOWED, IMMEDIATELY DRINK LARGE QUANTITIES OF WATER OR VEGETABLE OIL. SEEK IMMEDIATE MEDICAL ATTENTION.**

**BATTERIES PRODUCE EXPLOSIVE GAS; KEEP THEM AWAY FROM NAKED FLAMES, SPARKS AND CIGARETTES. IF THE BATTERY IS CHARGED IN A CLOSED PLACE, TAKE CARE TO ENSURE ADEQUATE VENTILATION. ALWAYS PROTECT YOUR EYES WHEN WORKING CLOSE TO BATTERIES.**

**KEEP OUT OF THE REACH OF CHILDREN**

**CAUTION**

**NEVER USE FUSES WITH A CAPACITY HIGHER THAN THE RECOMMENDED CAPACITY. USING A FUSE OF UNSUITABLE RATING MAY SERIOUSLY DAMAGE THE VEHICLE OR EVEN CAUSE A FIRE.**

---

**Levels check****Level check:**

- Hydraulic brake system liquid level.
  - Rear hub oil level
  - Engine coolant level
  - Engine oil level
- 

**Road test****Test ride**

- Cold start
  - Instrument operations
  - Response to the throttle control
  - Stability on acceleration and braking
  - Rear and front brake efficiency
  - Rear and front suspension efficiency
  - Abnormal noise
- 

**Static test****Static test after test ride:**

- Restarting when warmed up
-

- Starter operation
  - Minimum hold (turning the handlebar)
  - Uniform turning of the steering
  - Possible leaks
  - Operation of the radiator electric fan
- 

## Functional inspection

### Operating test:

- Hydraulic brake system
- Lever travel
- Clutch - Check for correct operation
- Engine - Check for correct general operation and make sure there is no unusual noise
- Other
- Check documents:
- Check the frame and engine numbers
- Check tool kit
- License plate fitting
- Check locks
- Check tyre pressures
- Installation of mirrors and any accessories

### CAUTION

**NEVER EXCEED THE RECOMMENDED INFLATION PRESSURES OR TYRES MAY BURST.**

### CAUTION

**CHECK AND ADJUST TYRE PRESSURE WITH TYRES AT AMBIENT TEMPERATURE.**

---

## INDEX OF TOPICS

TIME

TIME

---

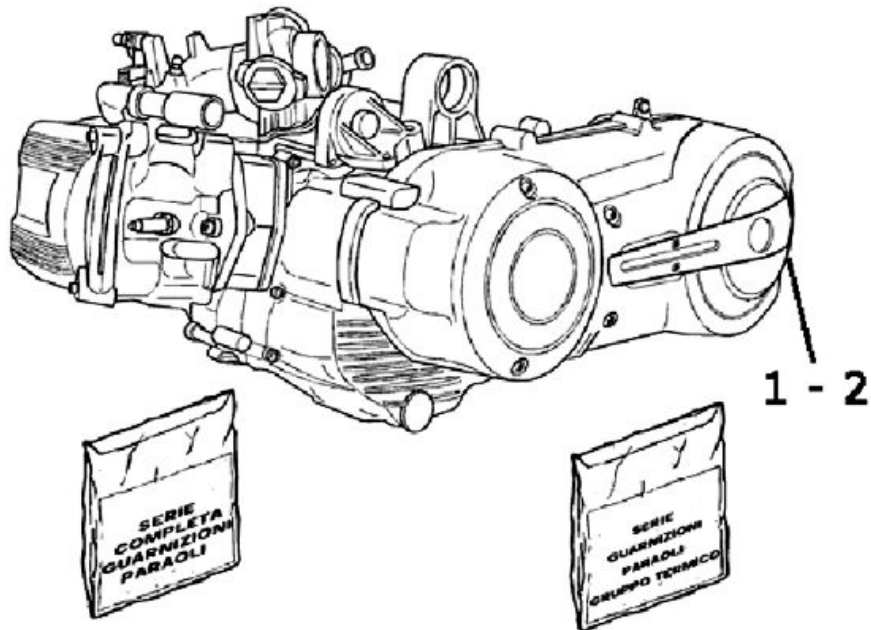
**Engine**



---

**ENGINE**

	Code	Action	Duration
1	001001	Engine from chassis - replacement	
2	003057	Engine retainer - Tighten nuts	

---

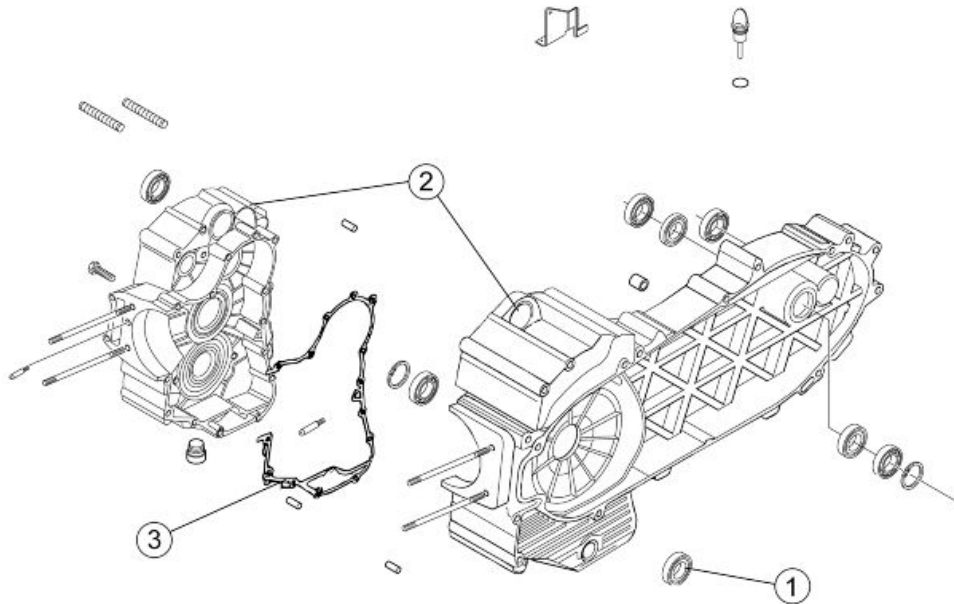
**Crankcase**



**CRANKCASE**

	<b>Code</b>	<b>Action</b>	<b>Duration</b>
1	001100	Oil seal, clutch side - Replacement	
2	001133	Engine crankcase- Replacement	
3	001153	Crankcase half gasket - Replacement	

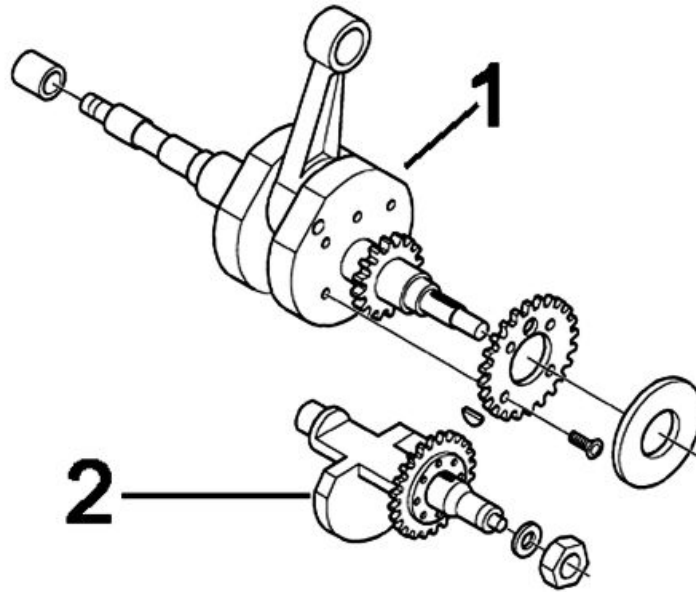
**Crankshaft****CRANKSHAFT**

	<b>Code</b>	<b>Action</b>	<b>Duration</b>
1	001117	Crankshaft - Replacement	
2	001098	Countershaft - Replacement	

Cylinder assy.

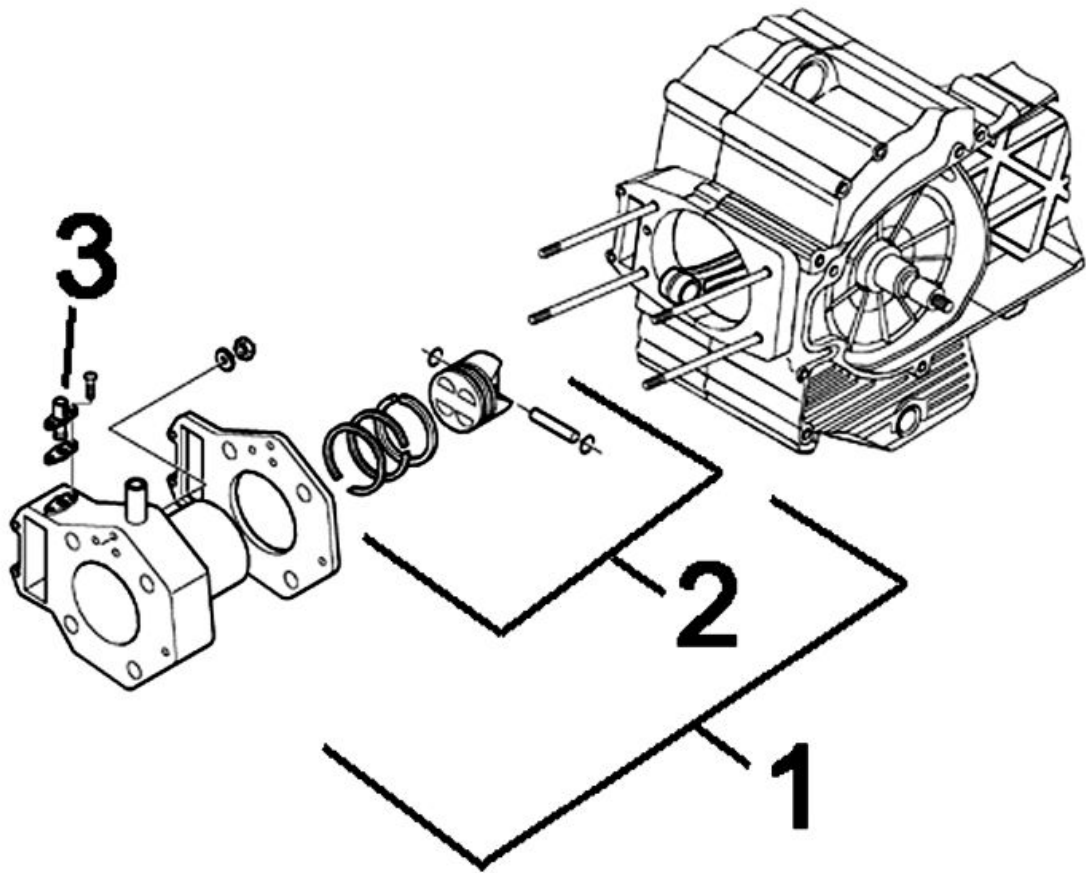

**CYLINDER GROUP**

	<b>Code</b>	<b>Action</b>	<b>Duration</b>
1	001002	Cylinder piston - Replacement	
2	001154	Pin-ring-piston assembly - Service	
3	001129	Chain tensioner - Service and Replacement	

Cylinder head assy.

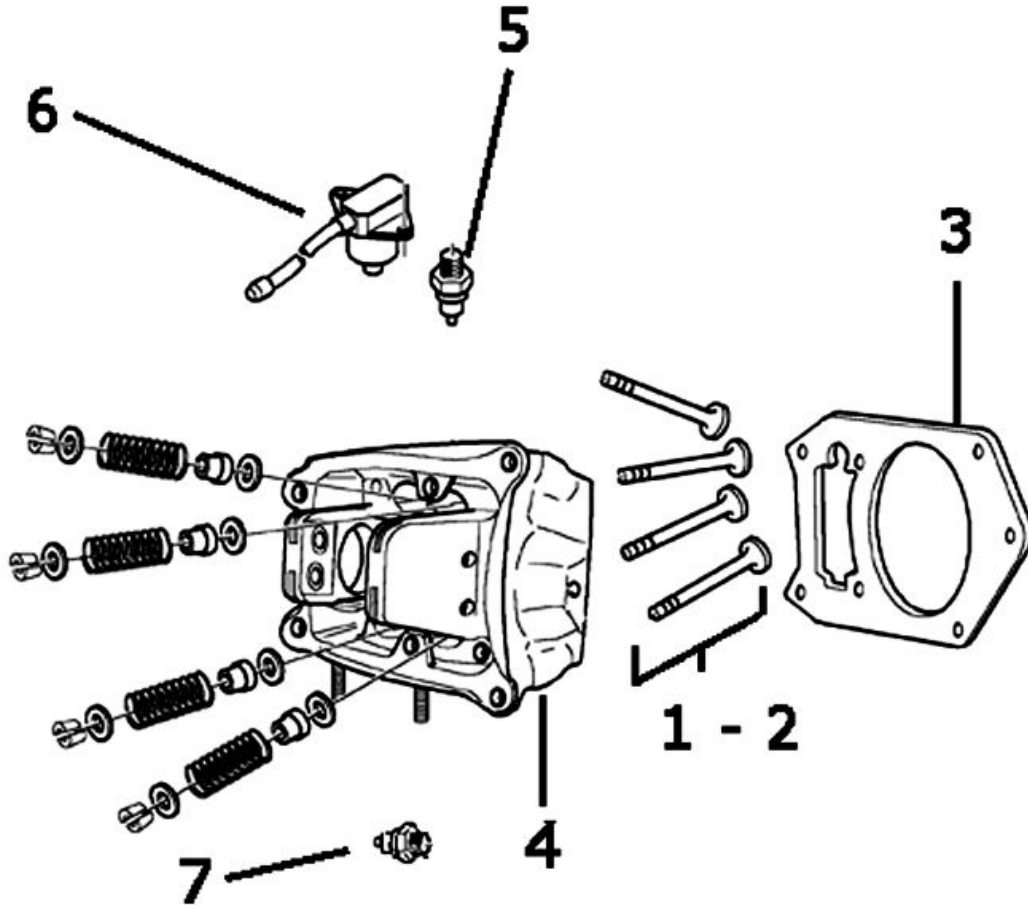

**HEAD UNIT**

	Code	Action	Duration
1	001045	Valves - Replacement	
2	001049	Valves - Adjustment	
3	001056	Head gasket - Replacement	
4	001126	Head - Replacement	
5	005081	Temperature sensor - Replacement	
6	005116	Rpm timing sensor - Replacement	
7	007012	Coolant bleed valve - Replacement	



Rocker arms support assy.

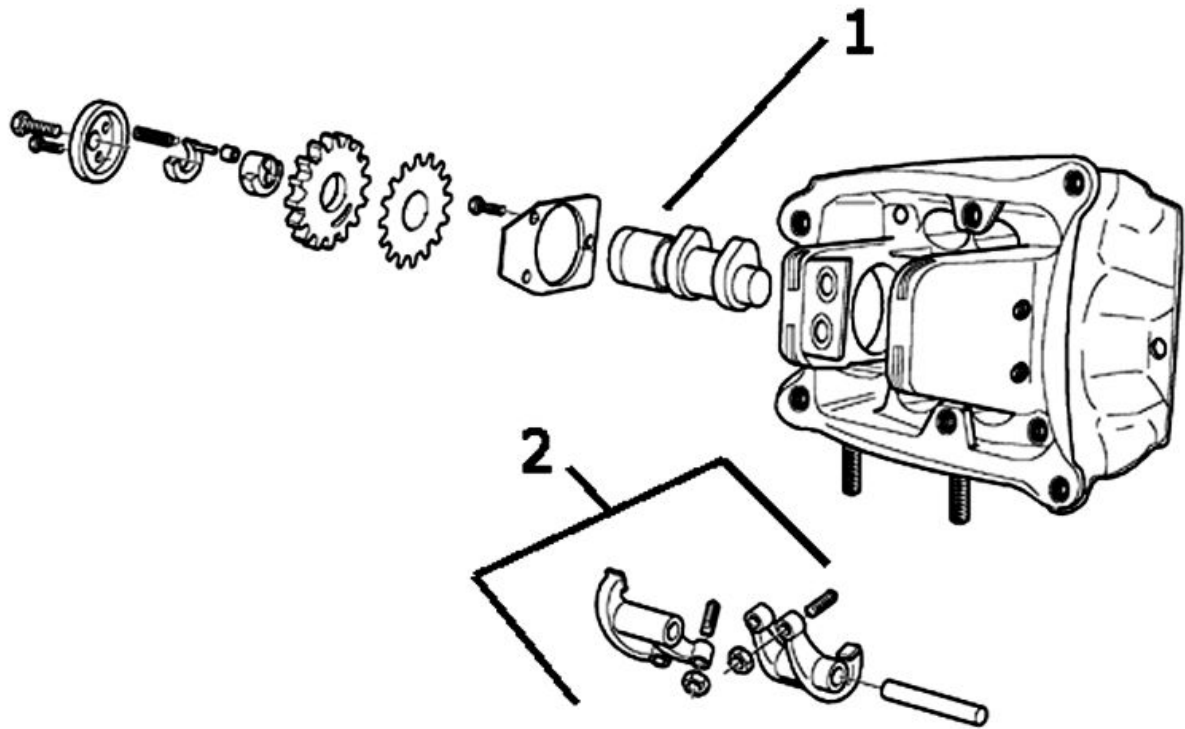

**ROCKING LEVER SUPPORT UNIT**

	Code	Action	Duration
1	001044	Camshaft - Replacement	
2	001148	Rocking lever valve - Replacement	

## Cylinder head cover

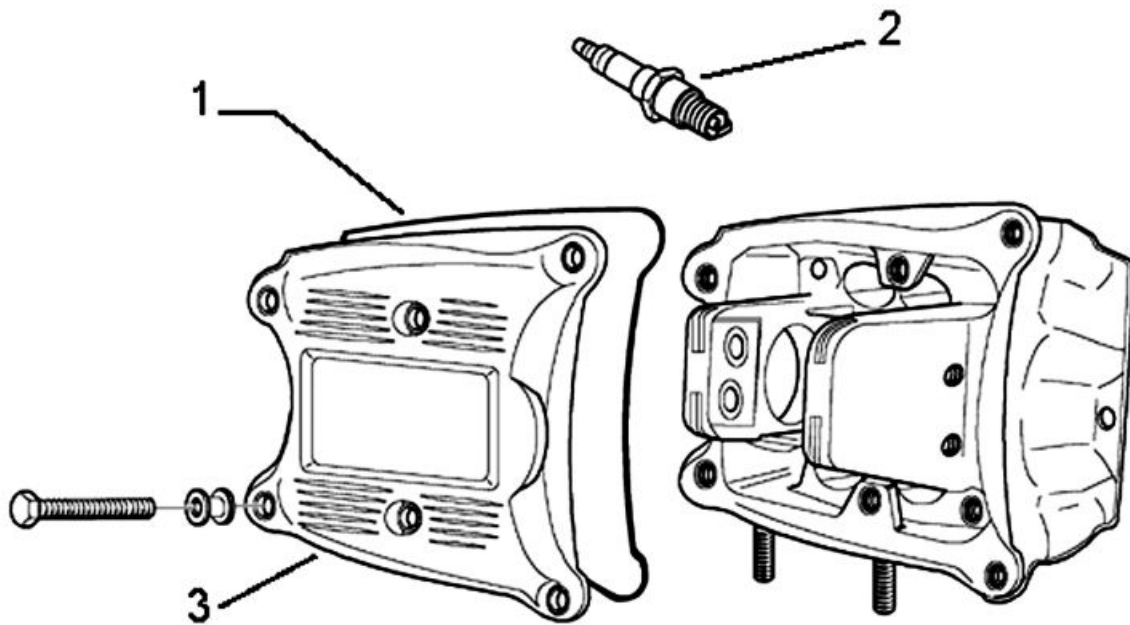

### HEAD COVER

	Code	Action	Duration
1	001089	Head cover - Replacement	
2	001093	Spark plug - Replacement	
3	001088	Head cover gasket - Replacement	

Flywheel cover

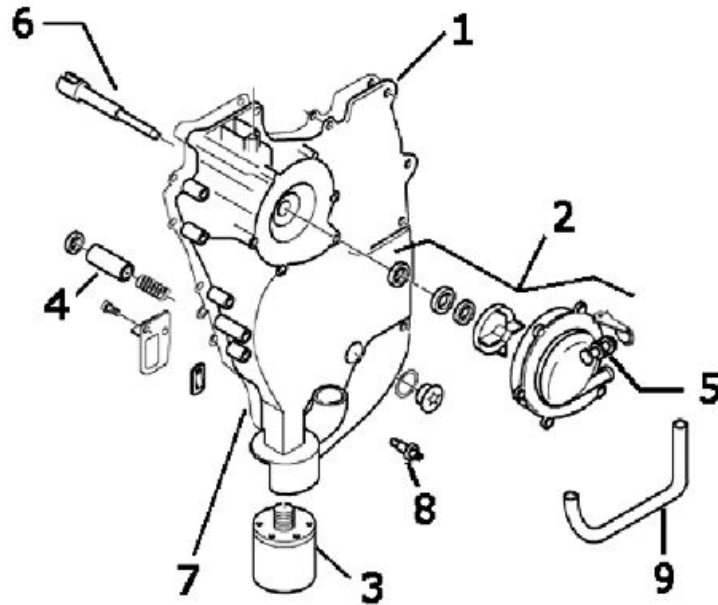

**FLYWHEEL COVER**

	Code	Action	Duration
1	001087	Flywheel cover - Replacement	
2	001113	Water pump - Replacement	
3	001123	Oil filter -Replacement	
4	001124	By-pass valve - Replacement	
5	001057	Thermostat - Replacement	
6	001062	Water pump command shaft - Replacement	
7	001150	Flywheel cover gasket - Replacement	
8	001160	Minimum oil pressure sensor - Replacement	
9	007011	By-pass manifold - thermostat - drain valve - Replacement	

## Driven pulley

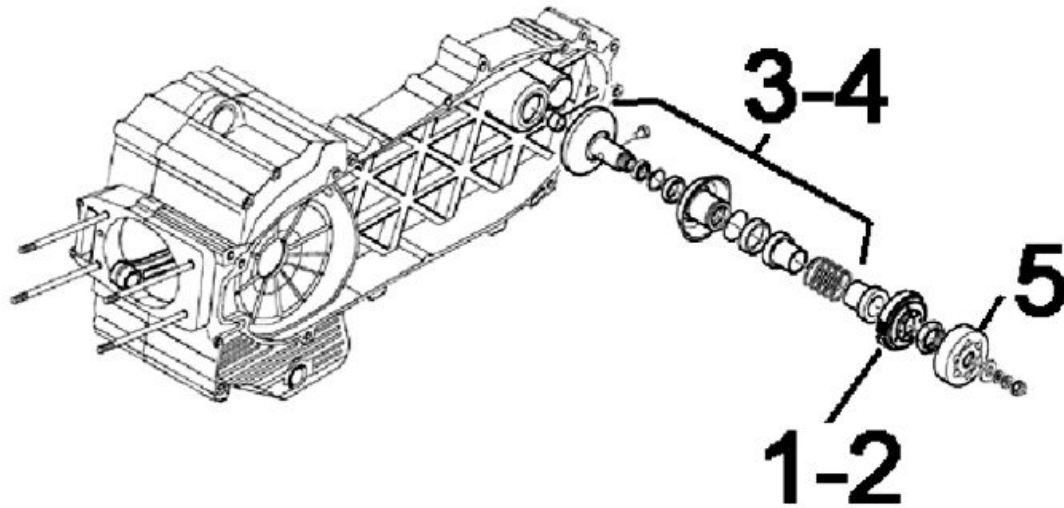

### DRIVEN PULLEY

	Code	Action	Duration
1	001022	Clutch - Replacement	
2	003072	Clutch unit - Wear check	
3	001012	Driven pulley - Service	
4	001110	Driven pulley - Replacement	
5	001155	Clutch bell housing - Replacement	

## Oil pump

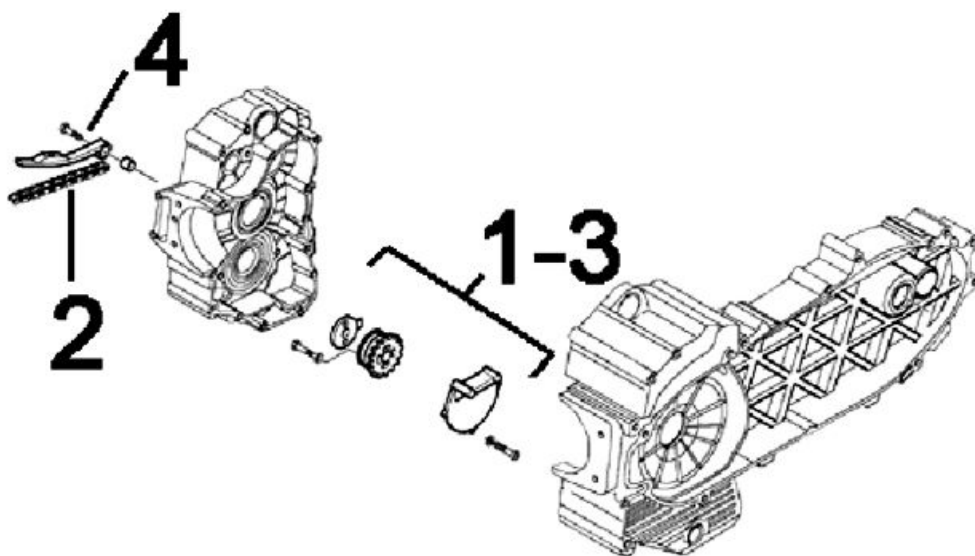

**OIL PUMP**

	Code	Action	Duration
1	001042	Oil pump - Service	
2	001051	Belt/Timing chain - Change	
3	001112	Oil pump - change	
4	001125	Chain guide pads - Replacement	

**Final gear assy.**

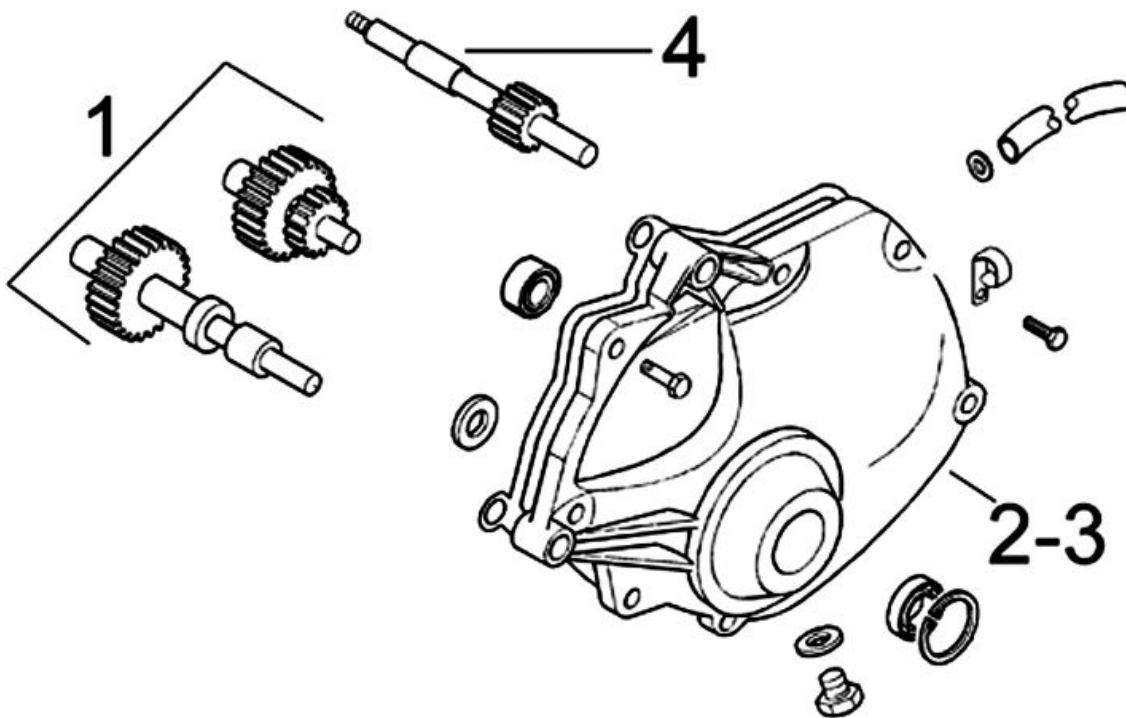

**FINAL REDUCTION GEAR ASSEMBLY**

	Code	Action	Duration
1	001010	Geared reduction unit - Service	
2	001156	Gear reduction unit cover - Replacement	
3	003065	Gear box oil - Replacement	
4	004125	Rear gear shaft - Replacement	

## Driving pulley

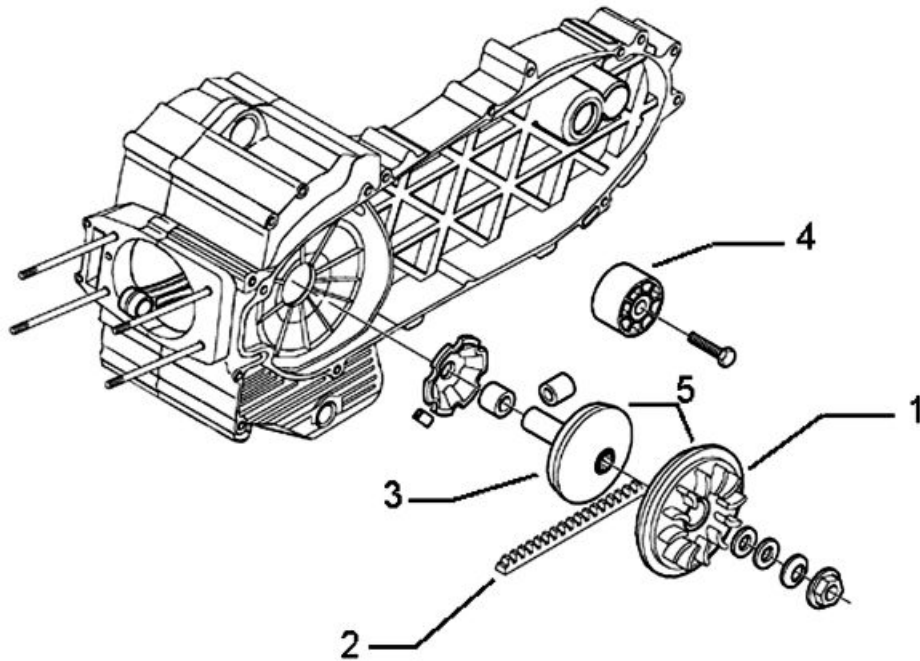

### DRIVING PULLEY

	Code	Action	Duration
1	001086	Driving half-pulley - Replacement	
2	001011	Driving belt - Replacement	
3	001006	rear-view pulley - Service	
4	001141	Belt anti-flapping roller - Replacement	
5	001066	rear-view pulley - Replacement	

Transmission cover

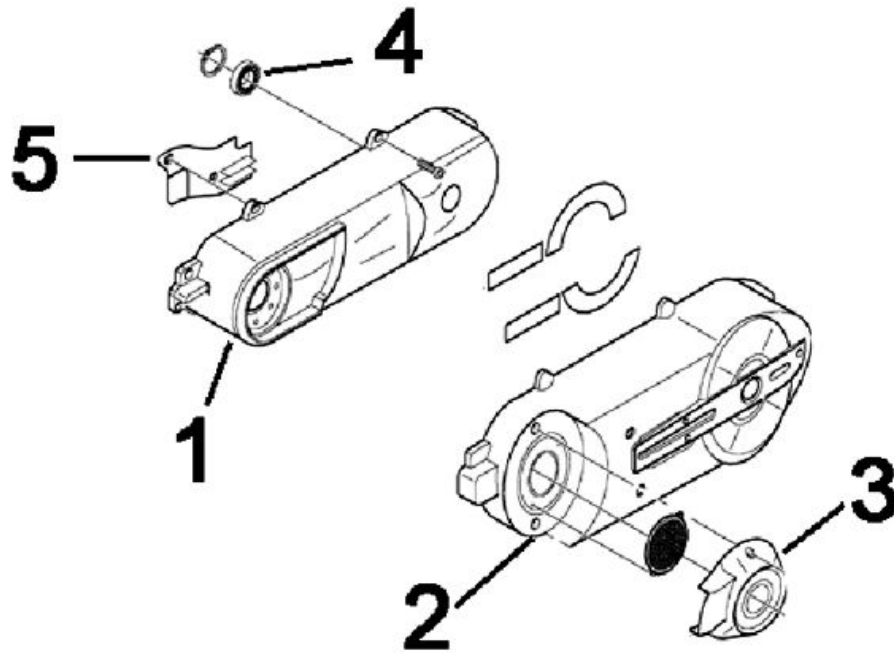

**TRANSMISSION COVER**

	<b>Code</b>	<b>Action</b>	<b>Duration</b>
1	001065	Internal transmission cover - Replacement	
2	001096	External transmission cover - Replacement	
3	001131	Transmission air intake - Replacement	
4	001135	Transmission cover bearing - Replacement	
5	001170	Air manifold - replacement	

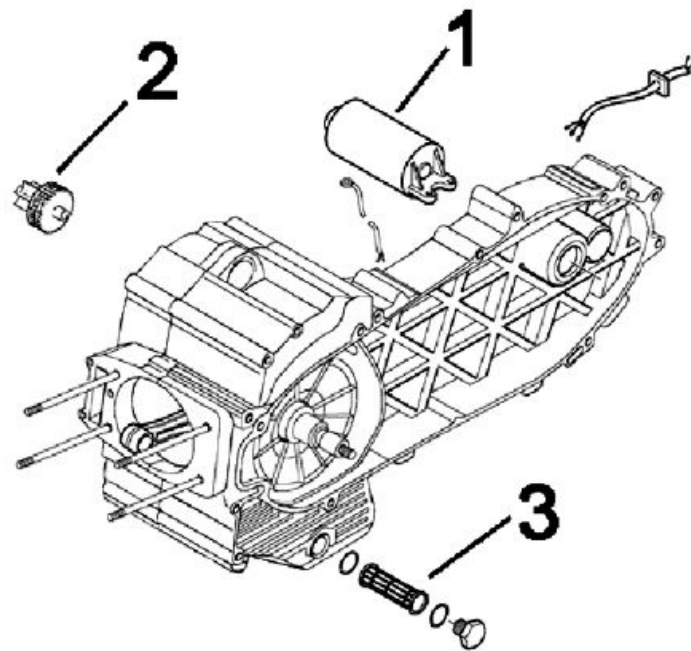
**Starter motor****STARTER MOTOR**

	<b>Code</b>	<b>Action</b>	<b>Duration</b>
1	001020	Starter motor - Replacement	
2	001017	Start-up pinion - Replacement	
3	003064	Engine oil - Change	



Flywheel magneto

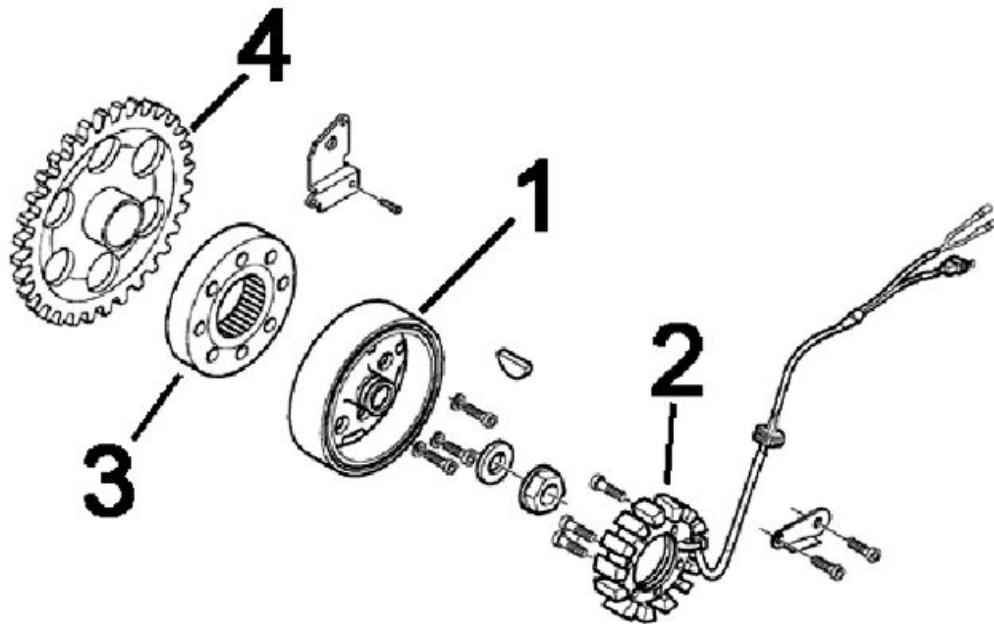

**MAGNETO FLYWHEEL**

	<b>Code</b>	<b>Action</b>	<b>Duration</b>
1	001058	Flywheel - Replacement	
2	001067	Stator - Replacement	
3	001104	Start-up freewheel - Replacement	
4	001151	Start-up driven gearing - Replacement	

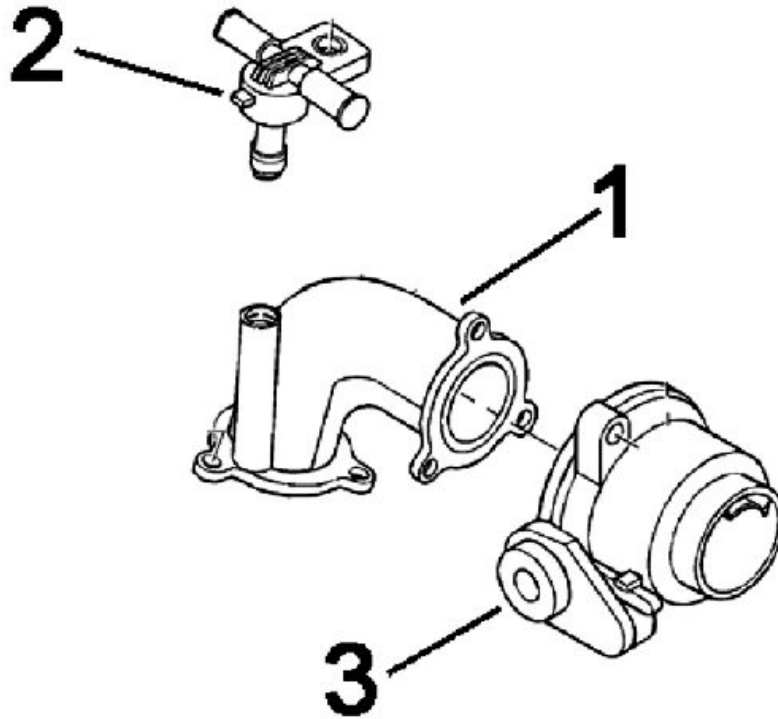
**Butterfly valve****THROTTLE BODY**

	<b>Code</b>	<b>Action</b>	<b>Duration</b>
1	001013	Intake manifold - Replacement	
2	001047	Injector - Replacement	
3	001166	Throttle body - Replacement	

Exhaust pipe

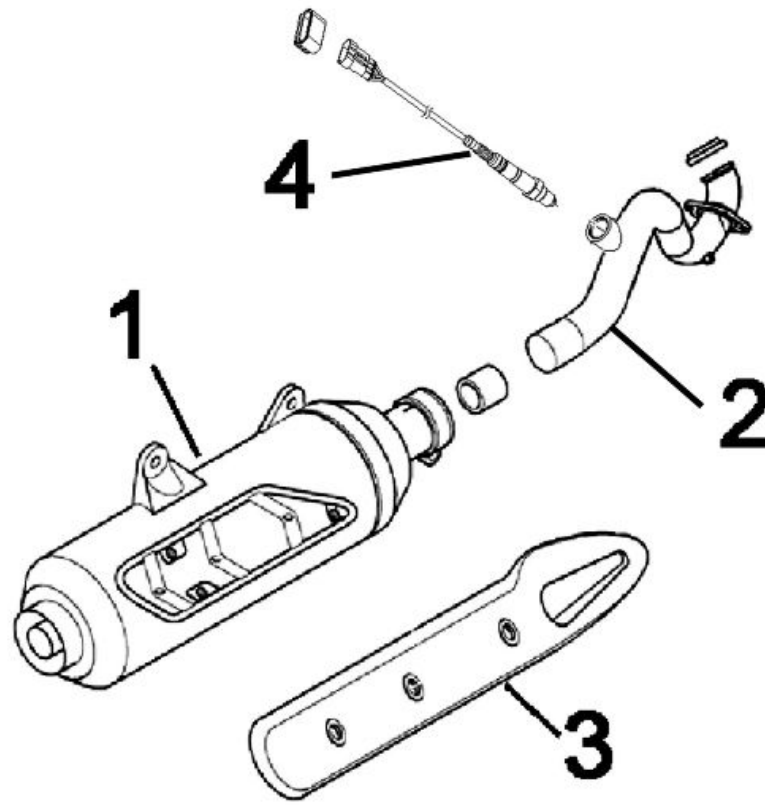

**MUFFLER**

	Code	Action	Duration
1	001009	Muffler - Replacement	
2	001092	Exhaust manifold - Replacement	
3	001095	Muffler guard - Replacement	
4	005138	Lambda probe - Replacement	

## Air cleaner

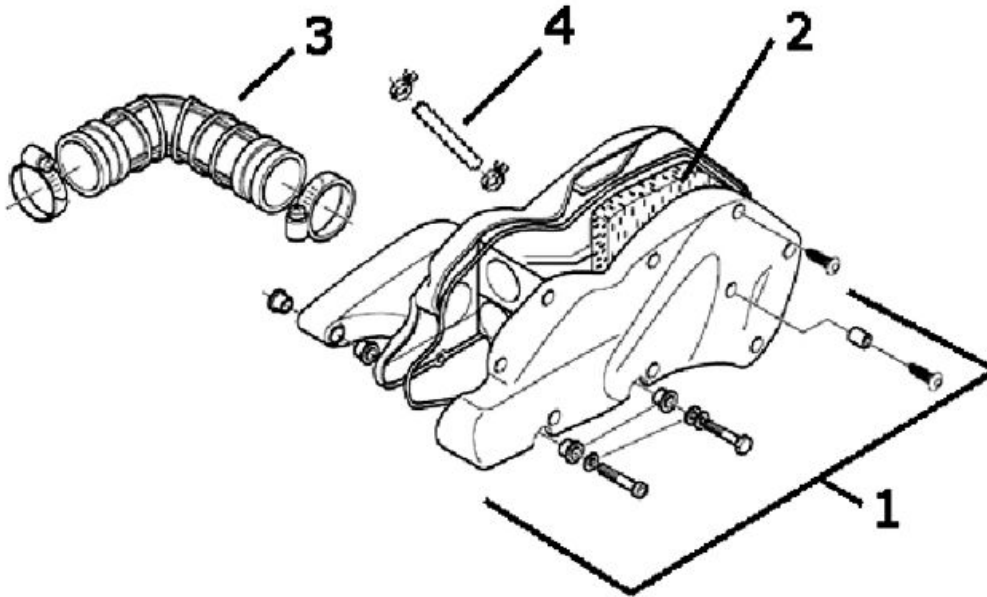

### AIR CLEANER

	Code	Action	Duration
1	001015	Air filter box - Replacement	
2	001014	Air filter - Replacement / cleaning	
3	004122	Cleaner / Throttle body union - Replacement	
4	001074	Oil vapour recovery pipe - Replacement	

Frame

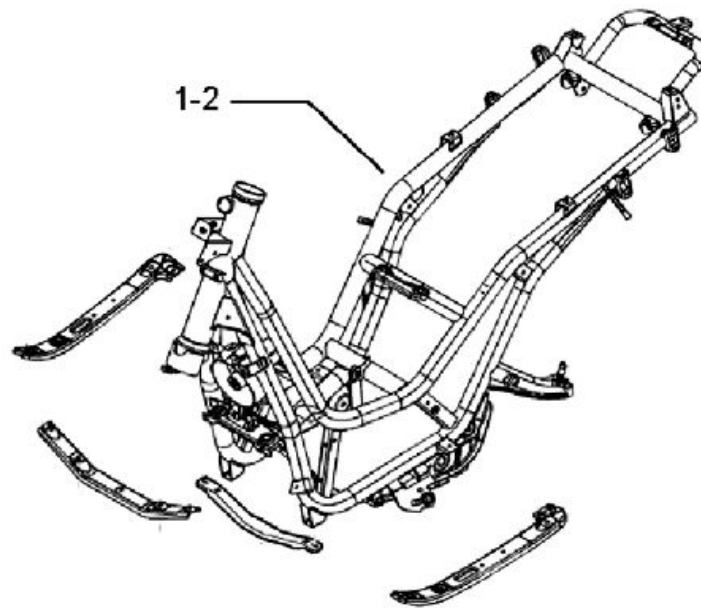

**CHASSIS**

	Code	Action	Duration
1	004001	Chassis - Replacement	
2	006001	Frame - Painting	

Centre-stand

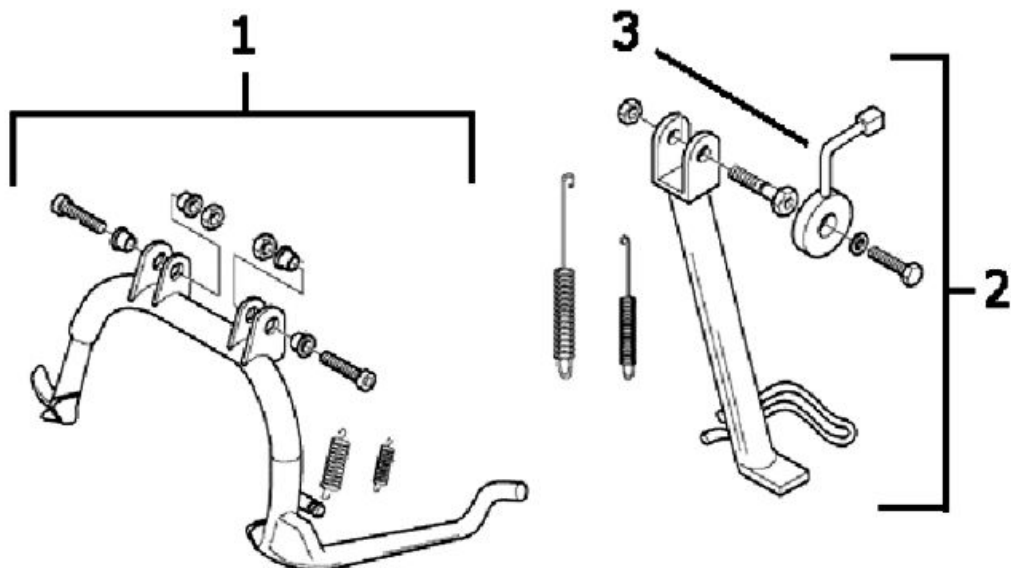

**CENTRE AND SIDE STANDS**

	Code	Action	Duration
1	004004	Stand - Replacement	
2	004102	Side stand - Replacement	
3	005079	Stand switch - Replacement	

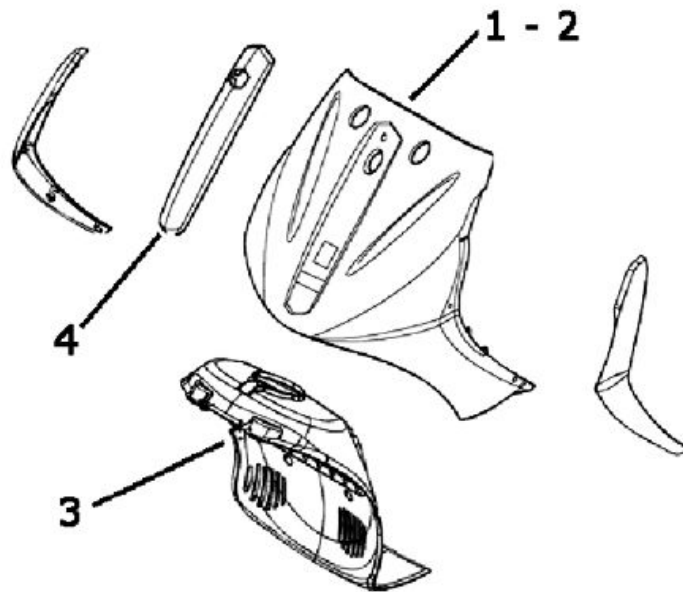
**Legshield spoiler****SPOILER FRONT SHIELD**

	Code	Action	Duration
1	004064	Legshield, front section - Replacement	
2	006012	Front shield - Paintwork	
3	004053	Spoiler - Replacement	
4	004149	Shield central cover - Replacement	

Side fairings

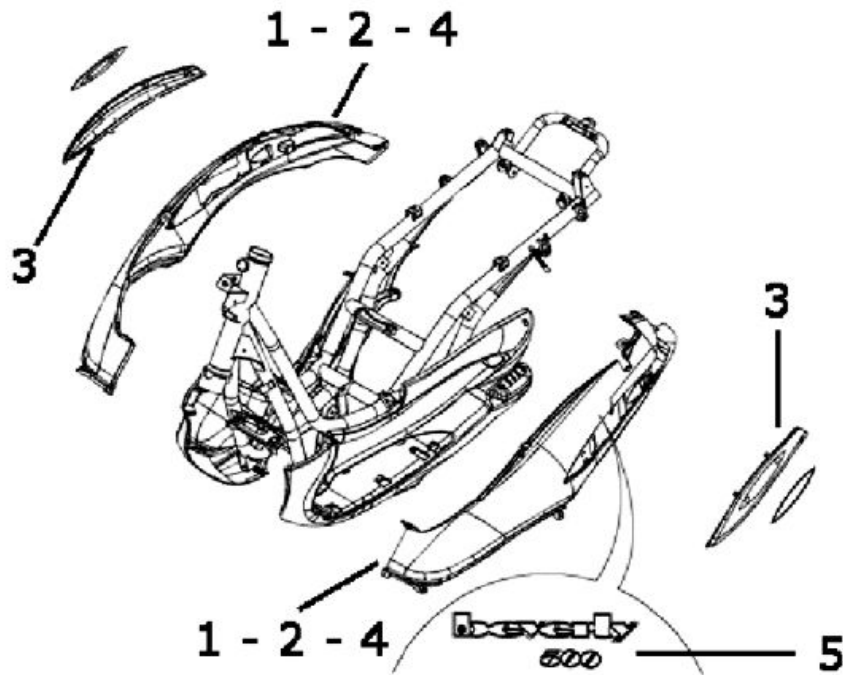

**SIDE COVERS**

	Code	Action	Duration
1	004085	Fairing (1) - Replacement	
2	006005	Side covers - Painting	
3	004129	Bumper fairing - Replacement	
4	004012	Fairings (2) - Replacement	
5	004159	Plates / Stickers - Replacement	

## Footrests

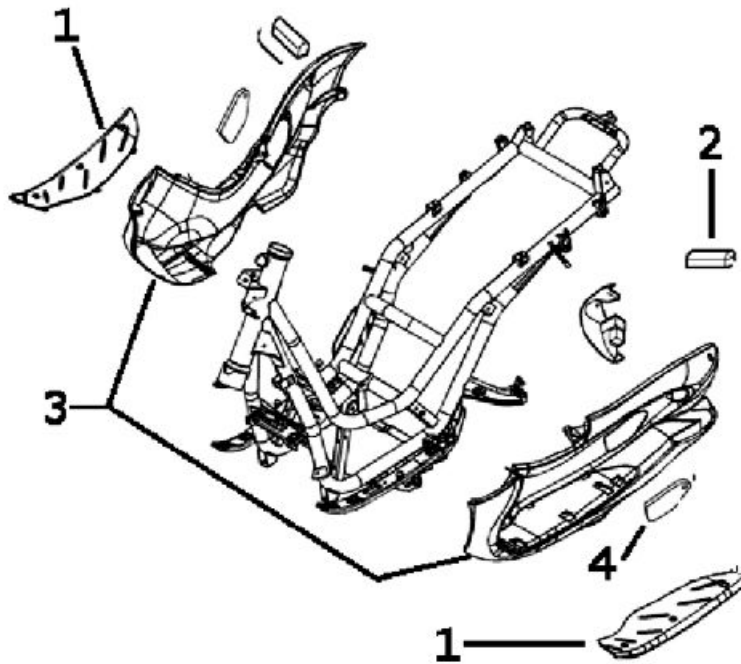
**MATS AND COVERS**

	<b>Code</b>	<b>Action</b>	<b>Duration</b>
1	004075	Front mat - Replacement	
2	004079	Passenger footrest (1) - Replacement	
3	004015	Footrest - Replacement	
4	004059	Spark plug inspection flap - Replacement	



Rear cover

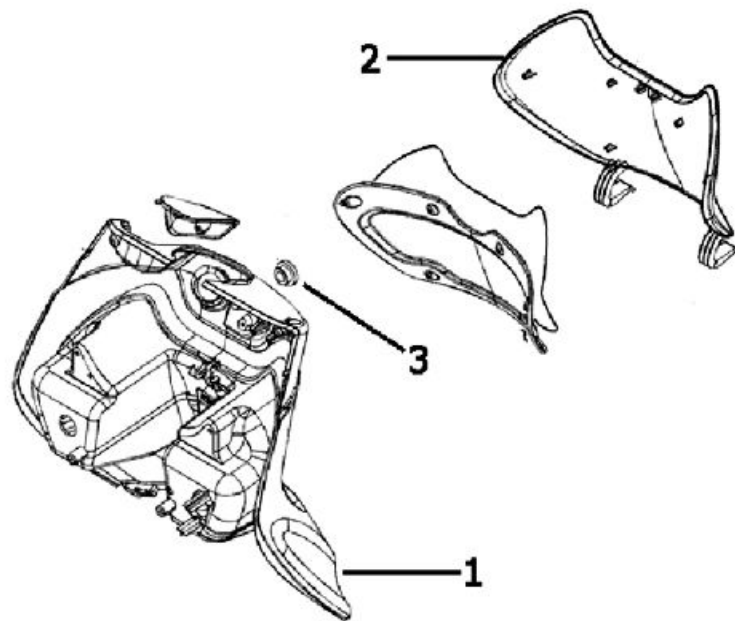

**REAR SHIELD**

	<b>Code</b>	<b>Action</b>	<b>Duration</b>
1	004065	Shield back plate - Replacement	
2	004081	Glove box door - Replacement	
3	005121	Saddle opening button - Replacement	

## Central cover

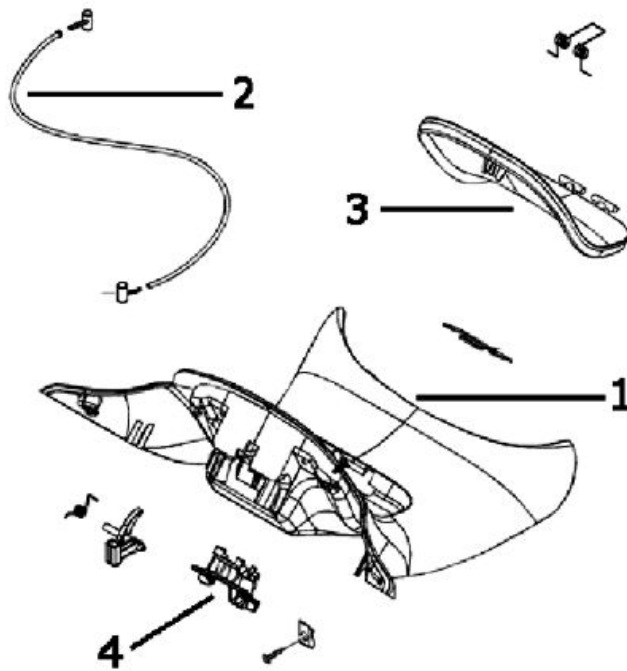

### CENTRAL COVER

	Code	Action	Duration
1	004011	Central chassis cover - Replacement	
2	002082	Fuel tank cap opening drive - Replacement	
3	004135	Fuel tank lid - Replacement	
4	004157	Fuel port coupling - Replacement	

Underseat compartment

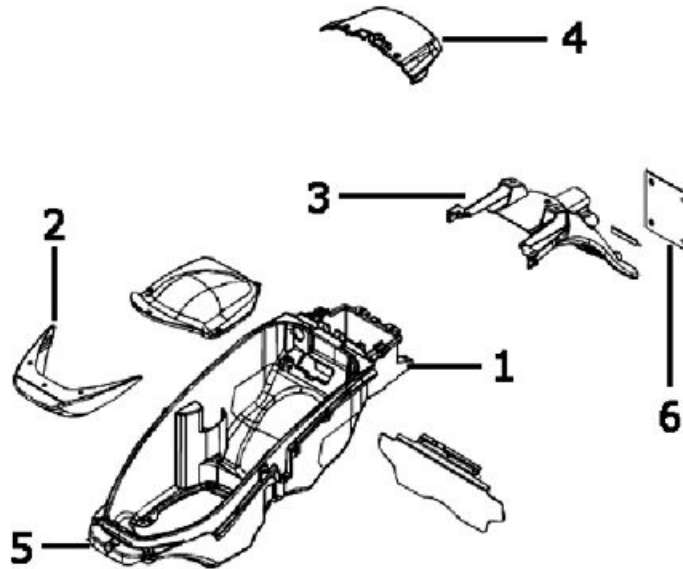

**HELMET COMPARTMENT**

	Code	Action	Duration
1	004016	Helmet compartment - Replacement	
2	004106	Under-saddle band - Replacement	
3	004136	License plate holder support - Replacement	
4	005046	Battery cover - change	
5	005033	Under seat light switch - Replacement	
6	005048	Licence plate holder - Replacement	

## Mudguard

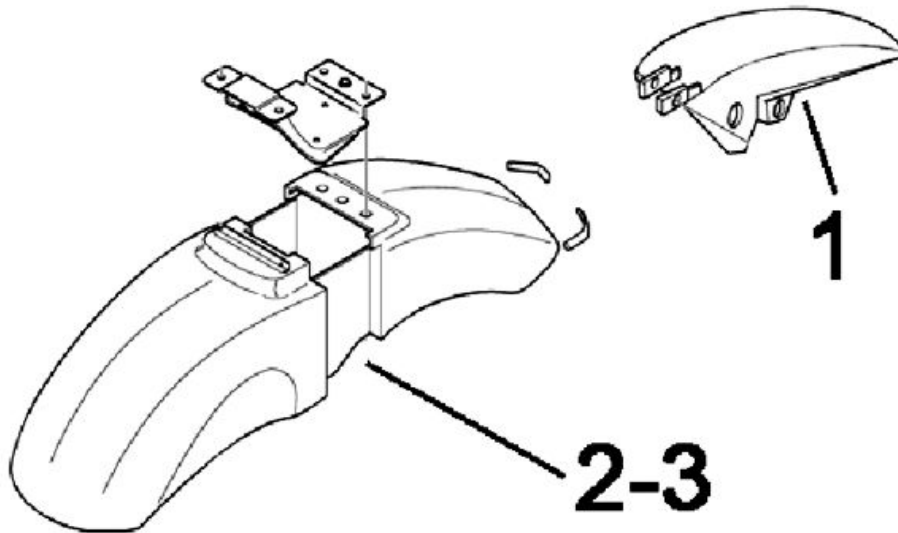

### MUDGUARD

	<b>Code</b>	<b>Action</b>	<b>Duration</b>
1	004009	Rear mudguard - Replacement	
2	004002	Front mudguard - Replacement	
3	006003	Mudguard - Painting	

Fuel tank

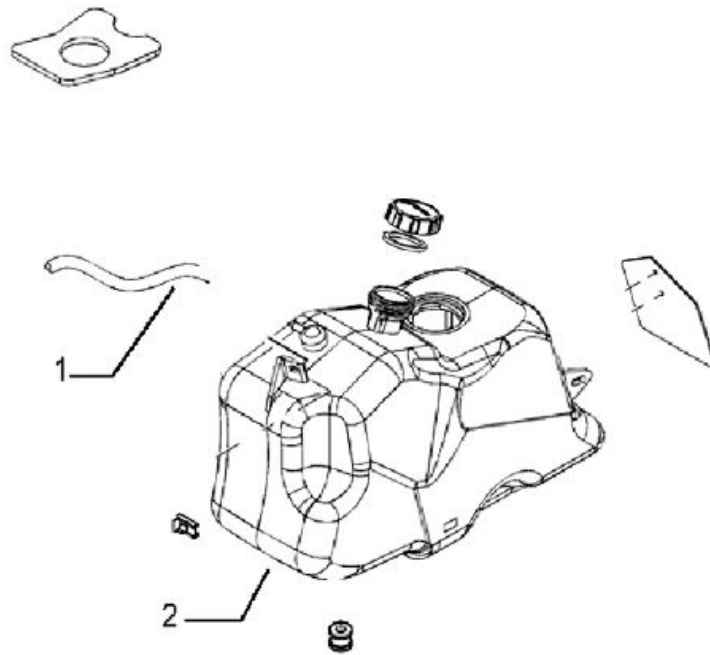

**FUEL TANK**

	<b>Code</b>	<b>Action</b>	<b>Duration</b>
1	004109	Fuel tank breather - Replacement	
2	004005	Fuel tank - Replacement	

## Expansion tank

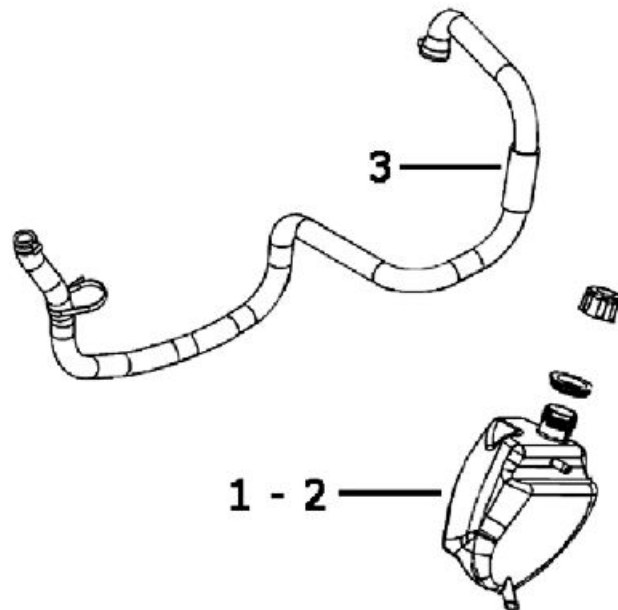

### EXPANSION TANK

	Code	Action	Duration
1	007001	Expansion tank - Replacement	
2	001052	Coolant and air bleed - Replacement	
3	007013	Expansion tank / radiator connecting hose - Replacement	

Radiator

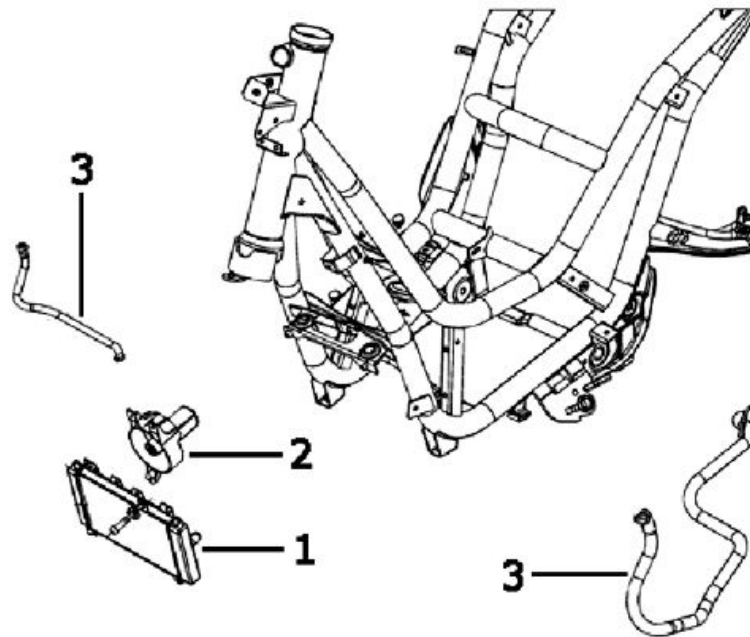

**RADIATOR**

	<b>Code</b>	<b>Action</b>	<b>Duration</b>
1	007002	Water cooling radiator - Replacement	
2	007016	Fan complete with support - Replacement	
3	007003	Delivery line and coolant return - Replacement	

### Rear shock-absorber

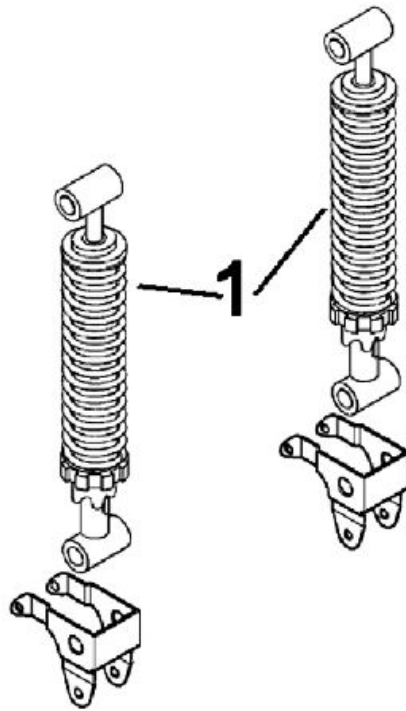

### REAR SHOCK ABSORBER

	Code	Action	Duration
1	003007	Rear shock absorbers - Replacement	

---



Steering column bearings

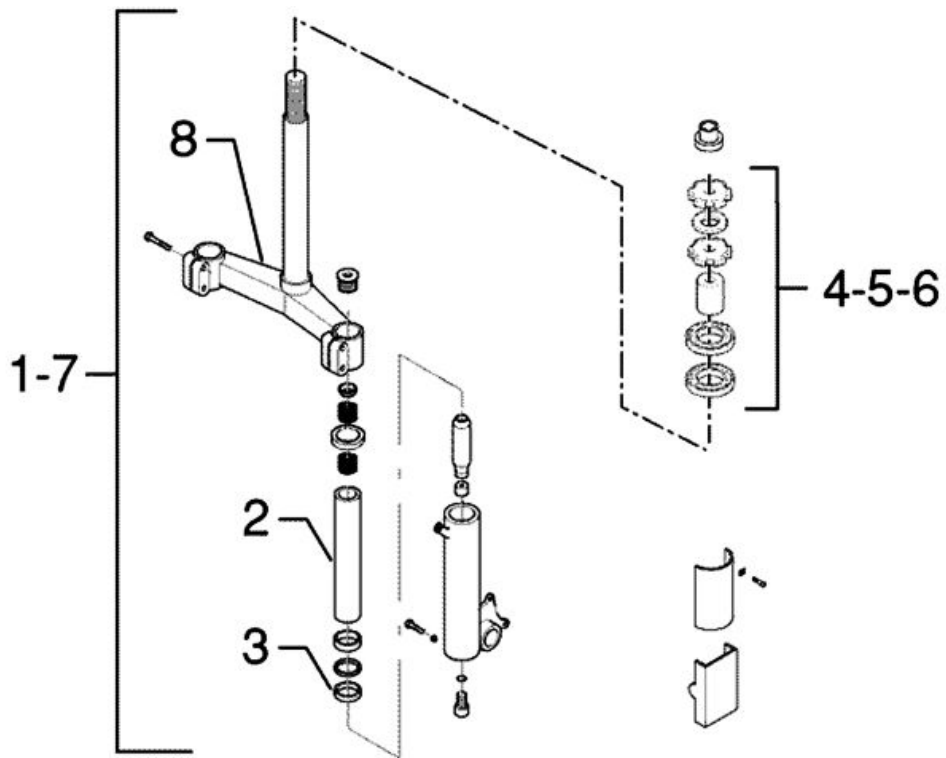

**STEERING FIFTH WHEELS**

	Code	Action	Duration
1	003051	Fork unit - Replacement	
2	003079	Fork stem - Replacement	
3	003048	Fork oil seal - Replacement	
4	004119	Bearing/upper steering fifth wheel - Replacement	
5	003002	Steering fifth wheel - Replacement	
6	003073	Steering clearance - Adjustment	
7	003010	Front suspension - Service	
8	003050	Fork lower plate - Replacement	

## Handlebar covers

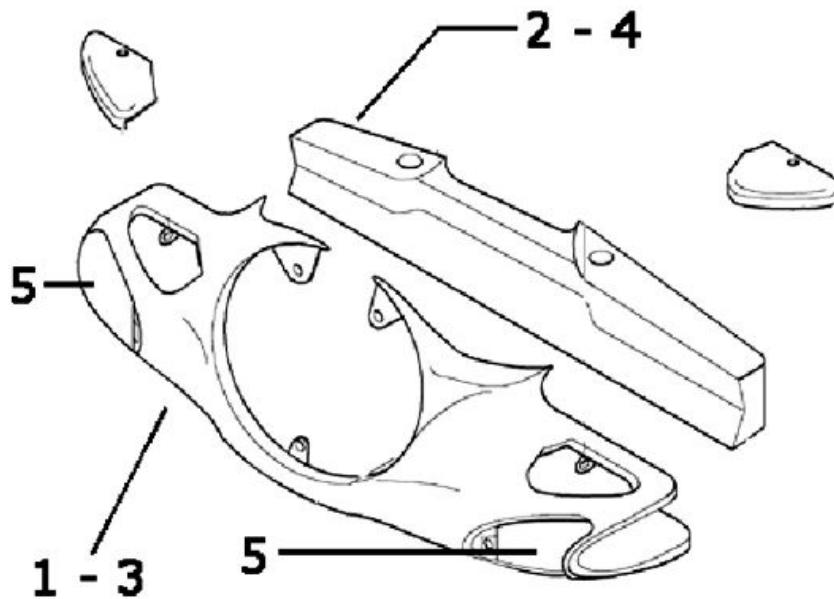

### HANDLEBAR COVER

	Code	Action	Duration
1	004018	Handlebar front section - Replacement	
2	004019	Handlebar rear section - Replacement	
3	006013	Handlebar front part - Painting	
4	006014	Handlebar rear part - Painting	
5	005091	Turn indicator glass - Replacement	

Handlebar components

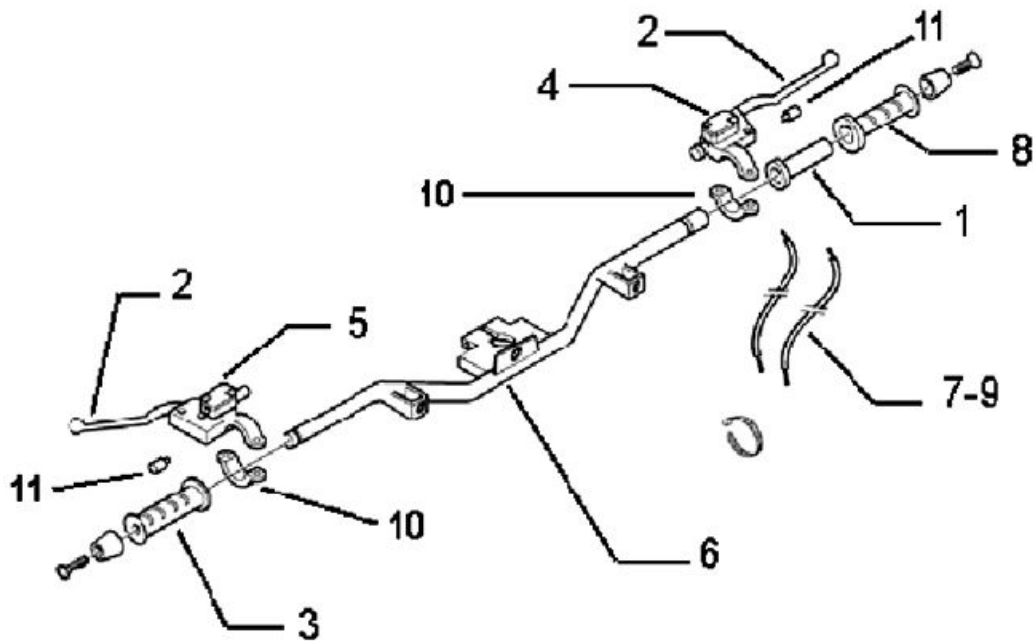

**HANDLEBAR COMPONENTS**

	Code	Action	Duration
1	002060	Throttle grip - Replacement	
2	002037	Brake or clutch lever - Replacement	
3	002071	Left hand grip - Replacement	
4	002024	Front brake pump - replace	
5	002088	Integral brake pump - Replacement	
6	003001	Handlebar - Replacement	
7	002063	Throttle control transmission - Replacement	
8	002059	Right hand grip - Replacement	
9	003061	Accelerator transmission - Adjustment	
10	004162	Mirror support and/or brake pump fitting U-bolt - Replacement	
11	005017	Stop switch - Replacement	

## Swing-arm

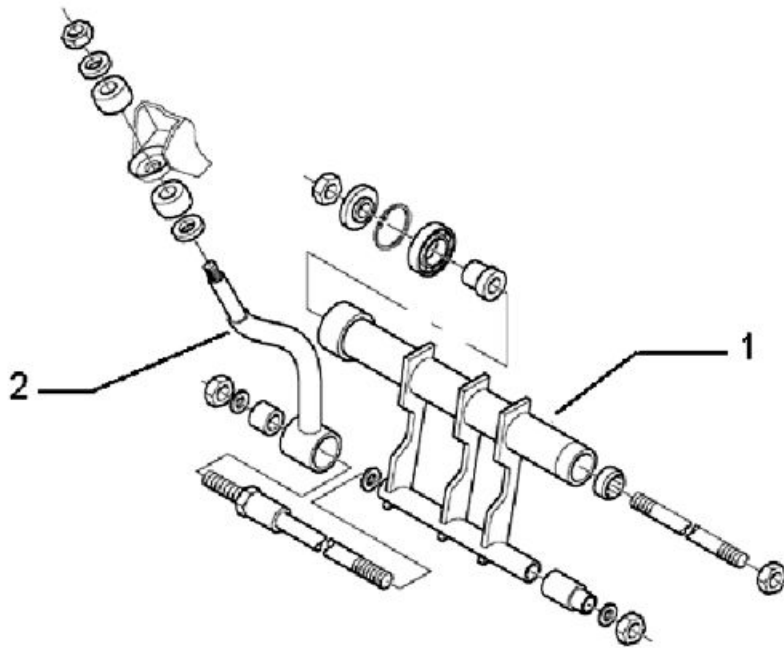

### SWINGING ARM

	Code	Action	Duration
1	001072	Swinging arm - Engine-chassis connection - Replacement	
2	003082	Damper arm - Replacement	

Brake hoses

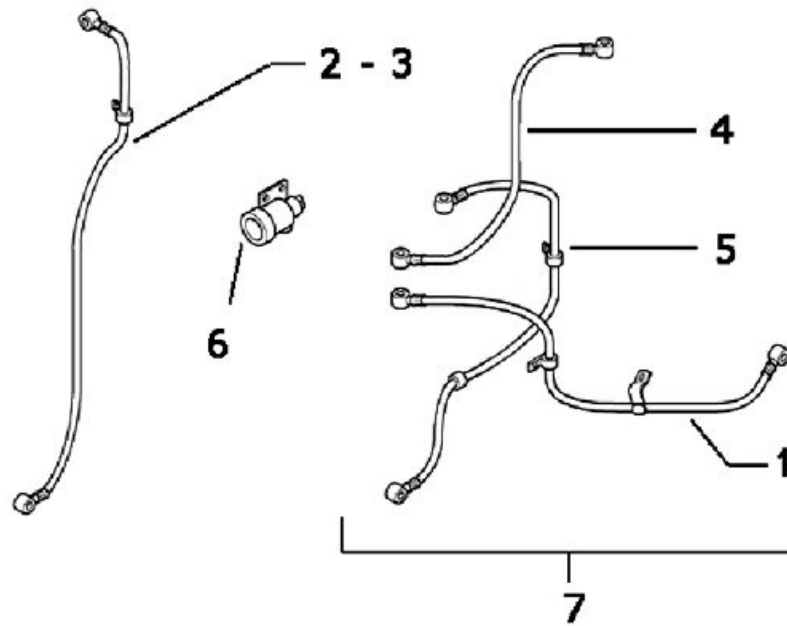

**BREAK PIPES**

	Code	Action	Duration
1	002020	Rear brake disc piping - Replacement	
2	002021	Front brake piping - Replacement	
3	002047	Front brake fluid and air bleeding system - Replacement	
4	002084	Integral break pump pipe, device - Replacement	
5	002085	Integral front brake pipes	
6	002089	Integral breaking device - Replacement	
7	002090	Integral brake fluid and bleeding system - Replacement	

**Seat**

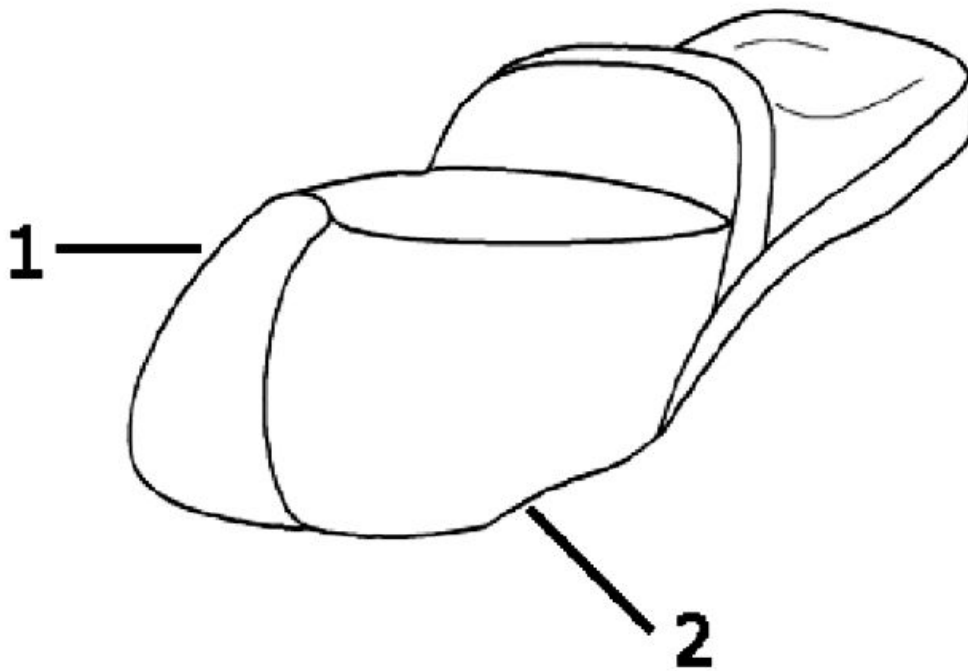

**SADDLE**

	<b>Code</b>	<b>Action</b>	<b>Duration</b>
1	004003	Saddle - Replacement	
2	004144	Saddle cover - Replacement	

---

Seat lock

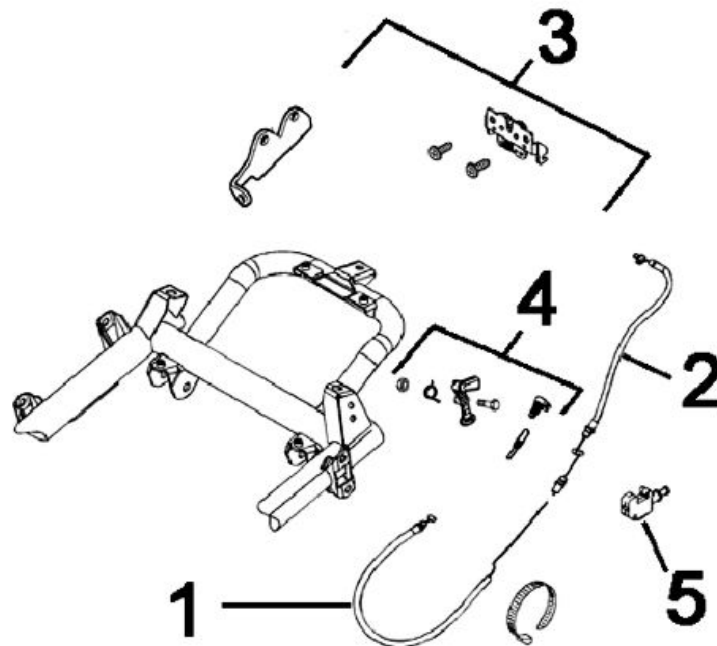

**SADDLE CLOSING MECHANISM**

	<b>Code</b>	<b>Action</b>	<b>Duration</b>
1	002083	Saddle opening transmission - Replacement	
2	002092	Transmission splitter/ hook transmission - Replacement	
3	004054	Saddle lock catch - Replacement	
4	004158	Saddle opening splitter - Replacement	
5	005099	Electric saddle opening device - Replacement	

## Instrument panel

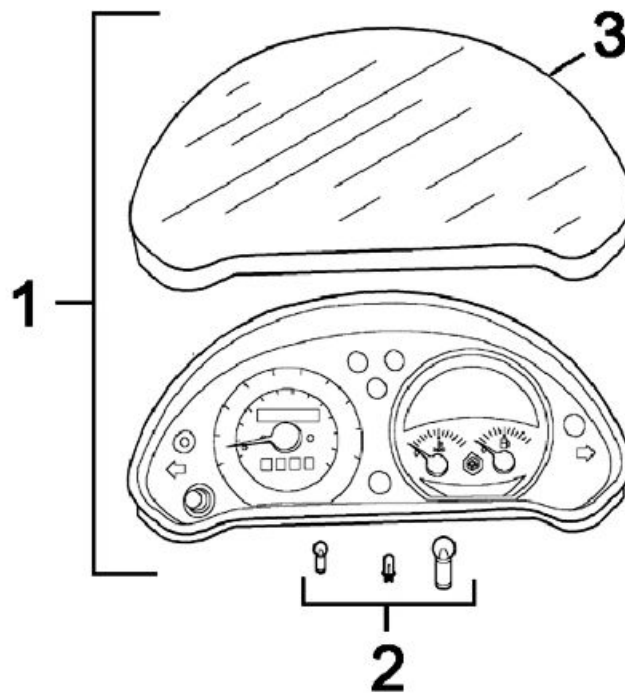
**LIGHT ASSEMBLY**

	<b>Code</b>	<b>Action</b>	<b>Duration</b>
1	005014	Instrument panel - Replacement	
2	005038	Instrument panel warning light bulbs - Replacement	
3	005078	Odometer glass - Replacement	



Rear rack

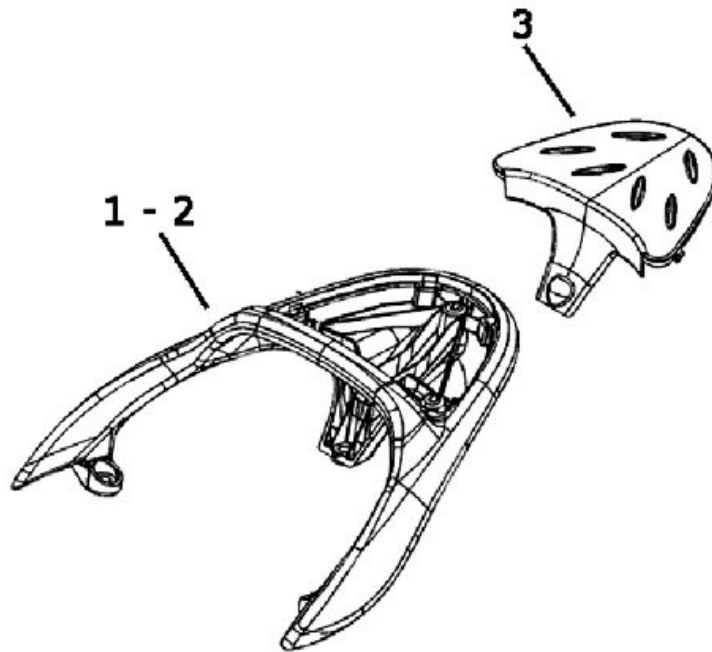

**LUGGAGE RACK**

	<b>Code</b>	<b>Action</b>	<b>Duration</b>
1	004008	Luggage rack - Replacement	
2	006002	Luggage rack - Painting	
3	004062	Luggage rack cover - Replacement	

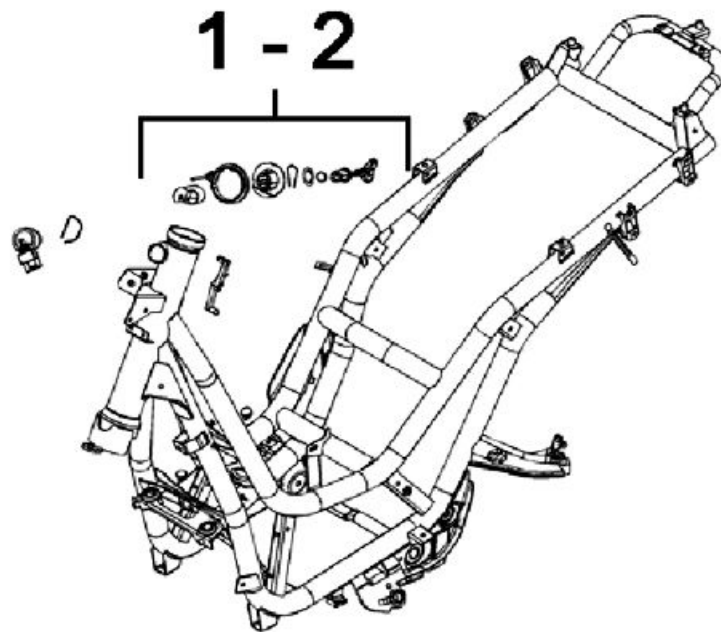
**Locks****LOCKS**

	<b>Code</b>	<b>Action</b>	<b>Duration</b>
1	005016	Key switch - Replacement	
2	004010	Anti-theft lock - Replacement	

Turn signal lights

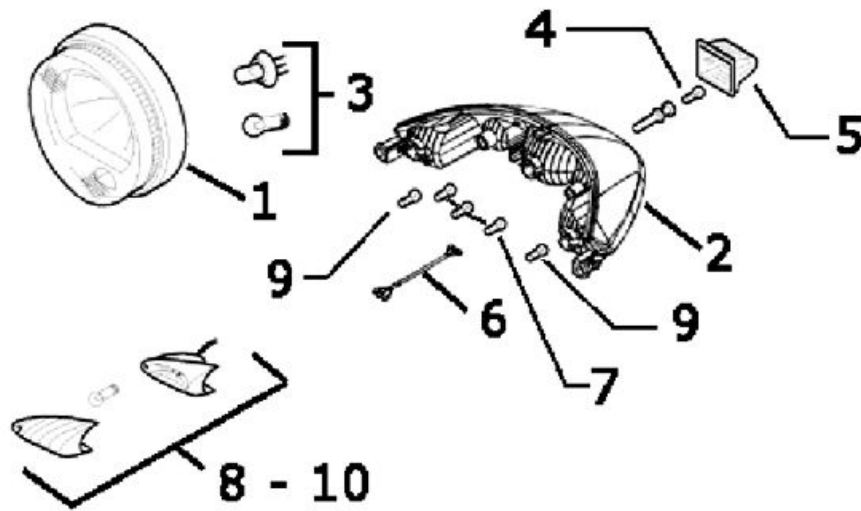

**TURN SIGNAL HEADLIGHTS**

	<b>Code</b>	<b>Action</b>	<b>Duration</b>
1	005002	Front headlamp - change	
2	005005	Taillight - Replacement	
3	005008	Front headlamp bulbs - Replacement	
4	005031	Licence plate light bulb - Replacement	
5	005032	Licence plate light glass - Replacement	
6	005044	Front lights cable unit- Replacement	
7	005066	Rear light bulbs - Replacement	
8	005067	Front turn indicator bulb - Replacement	
9	005068	Rear turn indicator bulb - Replacement	
10	005012	Front turn indicator - Replacement	

**Front wheel**

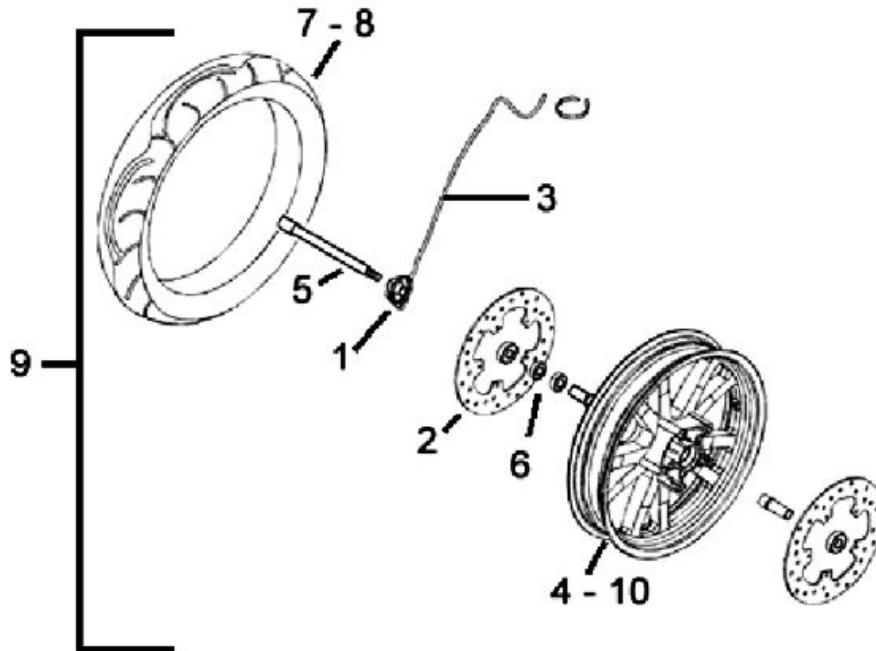

**FRONT WHEEL**

	<b>Code</b>	<b>Action</b>	<b>Duration</b>
1	002011	Odometer movement sensor - Replacement	
2	002041	Brake disc - Replacement	
3	002051	Odometer transmission assembly - Replacement	
4	003037	Front wheel rim- Replacement	
5	003038	Front wheel axle - Replacement	
6	003040	Front wheel bearings - Replacement	
7	003047	Front tyre - replace	
8	003063	Tyre pressure - Check	
9	004123	Front wheel - Replacement	
10	006018	Wheel rim - Paintwork	

**Grease tone wheel or drive**

Please take note that the code has been introduced:

900001 - Tone wheel / drive greasing - 15'.

Never mistake the codes 002011 (movement sensor replacement) and 005089 (tone wheel replacement) in the event of noise of the indicated components. The grease recommended is TUTELA MRM 2 (soap-based lithium grease with Molybdenum disulphide).

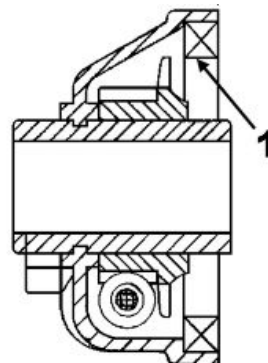

In the following points we indicate with an arrow the area to be greased (1 - Drive, 2 - Tone wheel)

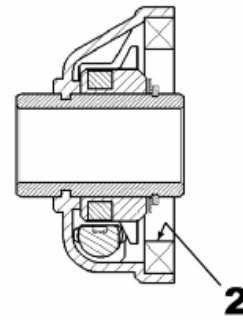

Rear wheel

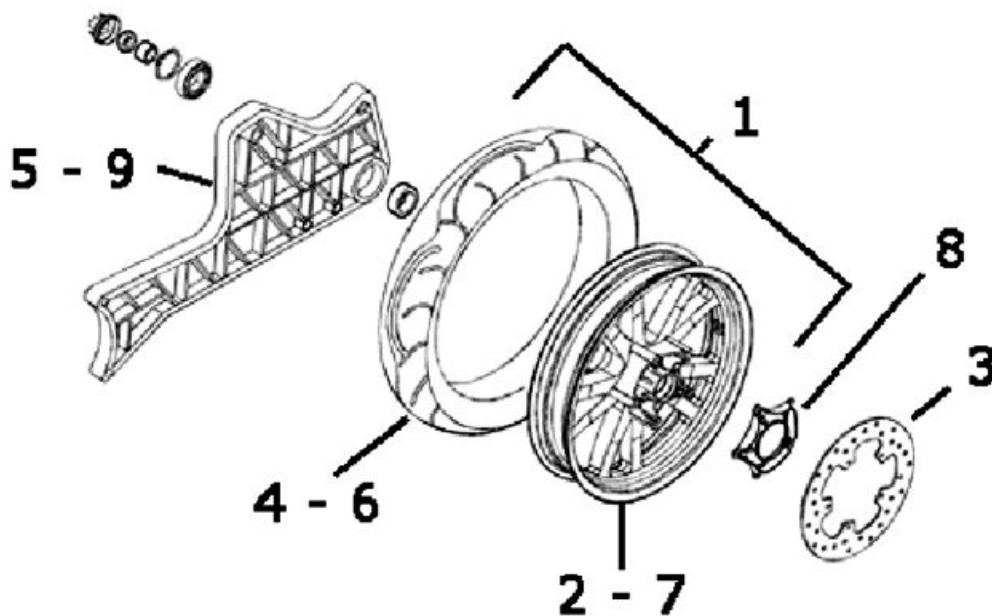

**REAR WHEEL**

	Code	Action	Duration
1	001016	Rear wheel - Replacement	
2	001071	Rear wheel rim - Removal and Refitting	
3	002070	Rear brake disc - Replacement	
4	003063	Tyre pressure - Check	
5	003077	muffler/rear shock absorber support arm - Service	
6	004126	Rear wheel tyre - Replacement	
7	006018	Wheel rim - Paintwork	
8	002028	Rear wheel hub - Replacement	
9	003014	Rear suspension arm - Replacement	

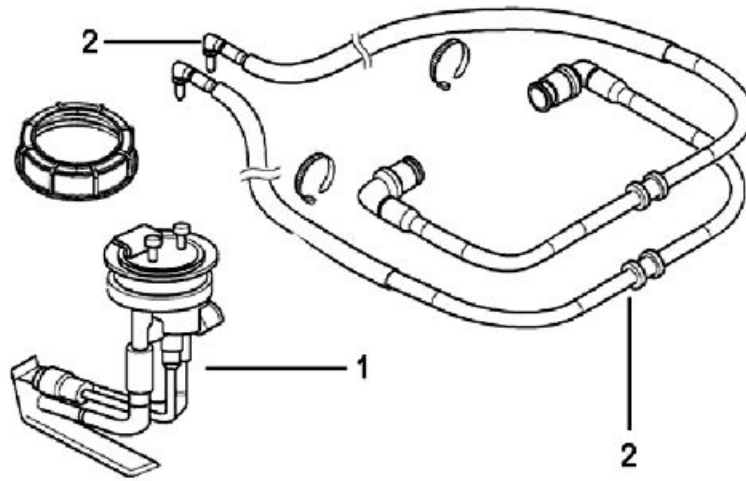
**Fuel pump****FUEL PUMP**

	<b>Code</b>	<b>Action</b>	<b>Duration</b>
1	004073	Fuel pump - Replacement	
2	004137	Injector pump pipe - Replacement	

Electric devices

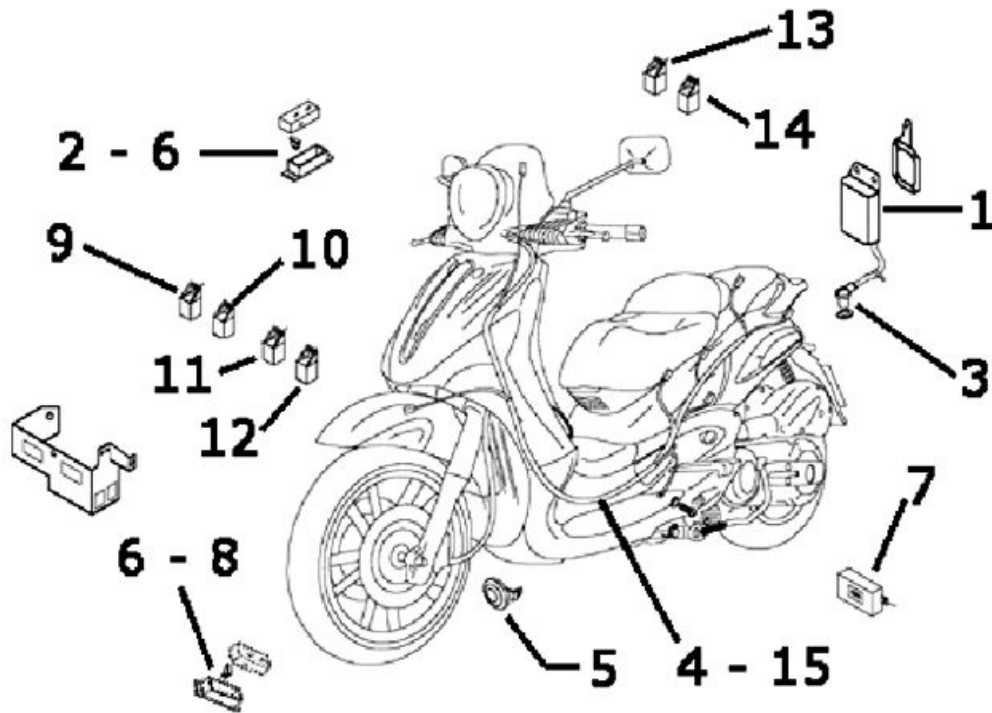

**ELECTRIC DEVICES**

	Code	Action	Duration
1	001069	HV coil - Replacement	
2	005054	Fuse holder - Replacement	
3	001094	Spark plug cap - Replacement	
4	005001	Electrical system - Replacement	
5	005003	Horn - Replacement	
6	005052	Fuse (1) - Replacement	
7	005115	Fuel level electrical damper - Replacement	
8	005080	Front fuse-holder - Replacement	
9	005035	Headlight remote control - Replacement	
10	005117	Electric fan remote control - Replacement	
11	005118	Arrows remote control - Replacement	
12	005096	Remote control for injection components - Replacement	
13	005119	Fuel pump remote control - Replacement	
14	005120	Control unit power supply remote control - Replacement	
15	005114	Electrical system - Service	

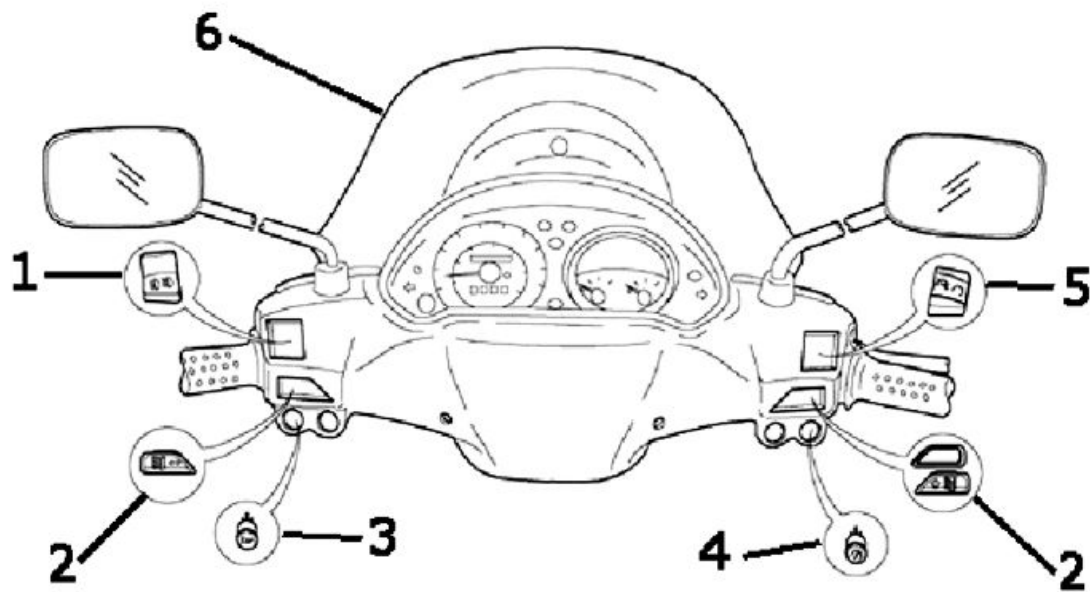

### **ELECTRIC DEVICES**

	<b>Code</b>	<b>Action</b>	<b>Duration</b>
1	005039	Headlight switch - Replacement	
2	005006	Light switch or turn indicators - Replacement	
3	005040	Horn button - Replacement	
4	005041	Starter button - Replacement	
5	005047	Emergency stop switch - change	
6	004117	Top fairing - Replacement	



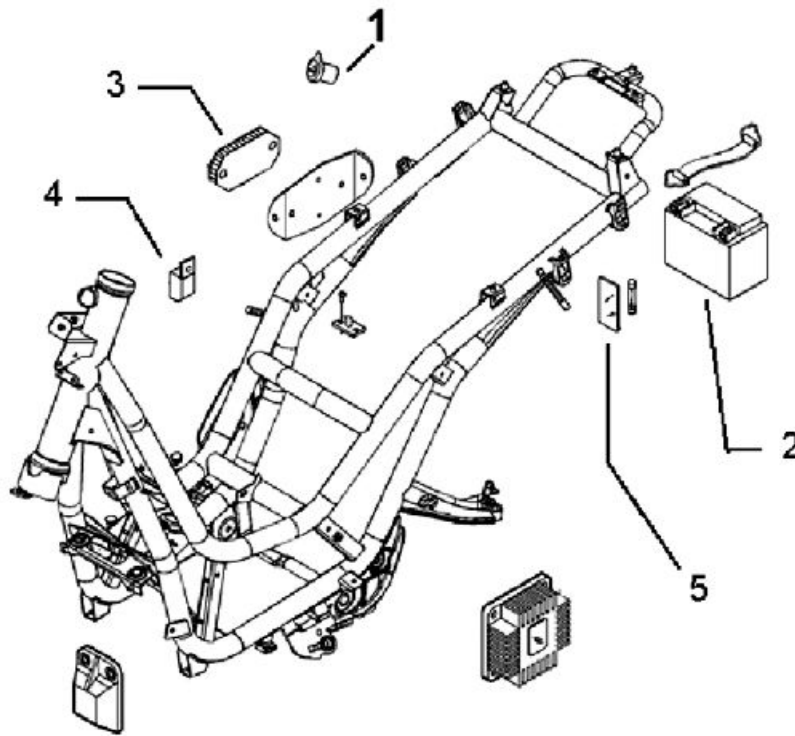

**ELECTRIC DEVICES**

	<b>Code</b>	<b>Action</b>	<b>Duration</b>
1	004142	Plug socket - Replacement	
2	005007	Battery - Replacement	
3	005009	Voltage regulator - Replacement	
4	005011	Start-up remote control switch - Replacement	
5	005026	Helmet compartment light - Replacement	
6	005027	Helmet compartment bulb support - Replacement	
7	005073	Immobilizer decoder - Replacement	
8	001023	Control unit - Replacement	

## Brake callipers

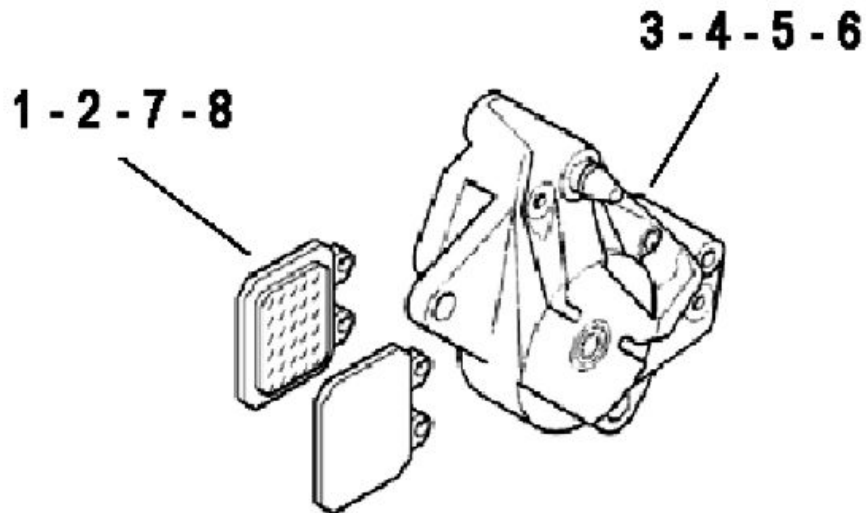

### FRONT BREAK CALLIPER

	Code	Action	Duration
1	002002	Rear brake pads - Replacement	
2	002007	Front brake pads - Replacement	
3	002039	Front brake calliper - Replacement	
4	002040	Front brake calliper - Check	
5	002048	Rear brake calliper - Replacement	
6	002068	Rear brake calliper - Check	
7	003070	Front brake pads - Wear check	
8	003071	Rear brake pads - Wear check	

## **A**

Air filter: 32, 336

## **B**

Battery: 48, 57, 63, 64

Brake: 299, 302, 304, 306, 307, 309, 311, 313, 381, 394

Brake fluid: 311

## **C**

Coolant: 246, 319

## **E**

Engine oil: 33

## **F**

Fuel: 11, 200, 210, 214, 338, 373, 390

Fuses: 60

## **H**

Headlight: 38, 327

Hub oil: 31

## **I**

Identification: 7

Immobilizer:

Instrument panel: 327, 384

## **L**

Light switch:

Luggage rack:

## **M**

Maintenance: 6, 29

## **O**

Oil filter: 33

## **S**

Saddle:

Shock absorbers: 295

Spark plug: 30, 244

Stand: 297

Start-up:

## T

Tank: 11, 338, 373, 374

Technical Data:

Transmission: 8, 72, 88, 359

Turn indicators: 52

Tyres: 9