

PIAGGIO WOULD LIKE TO THANK YOU

for choosing one of its products. We have prepared this booklet to help you to get the very best from your scooter. Please read it carefully before riding the scooter for the first time. It contains information, tips and precautions for using your scooter. It also describes features, details and devices to assure you that you have made the right choice. We believe that if you follow our suggestions, you will soon get to know your new vehicle and it will serve you well for a long time to come. This booklet forms an integral part of the scooter; should the scooter be sold, it must be transferred to the new owner.

# Beverly 125 - 250



The instructions given in this manual are intended to provide a clear, simple guide to using your scooter; this booklet also details routine maintenance procedures and regular checks that should be carried out on the vehicle at an **authorised Dealer or Service Centre**. The booklet also contains instructions for simple repairs. Any operations not specifically described in this manual require the use of special tools and/or particular technical knowledge: to carry out these operations refer to any **authorised Dealer or Service Centres**.



### **Personal safety**

Failure to completely observe these instructions will result in serious risk of personal injury.



### **Safeguarding the environment**

Sections marked with this symbol indicate the correct use of the vehicle to prevent damaging the environment.



### **Vehicle intactness**

The incomplete or non-observance of these regulations leads to the risk of serious damage to the vehicle and sometimes even the invalidity of the guarantee.

*The signs that you see on this page are very important. They are used to highlight those parts of the booklet that should be read with particular care. As you can see, each sign consists of a different graphic symbol, making it quick and easy to locate the various topics.*



# INDEX

**VEHICLE**..... 7  
Dashboard..... 8  
Analogue instrument panel..... 9  
Key switch..... 9  
    Locking the steering wheel..... 10  
    Releasing the steering wheel..... 10  
Switch direction indicators..... 10  
Horn button..... 11  
Light switch..... 11  
Start-up button..... 12  
Engine stop button..... 12  
The immobilizer system..... 12  
    Keys..... 13  
    Immobilizerdevice enabled indicator led..... 14  
    Operation..... 14  
    Programming the immobilizer system..... 15  
Accessing the fuel tank..... 16  
Power supply socket..... 17  
The saddle..... 17  
    Opening the saddle..... 19  
Identification..... 19  
Helmet Anti-theft Device..... 20  
**USE**..... 21  
    Checks..... 22  
    Refuelling..... 22  
    Shock absorbers adjustment..... 23  
    Running in..... 24  
    Starting up the engine..... 25  
        Precautions..... 26  
    Difficult start up..... 27  
    Stopping the engine..... 28  
    Stand..... 28  
    Automatic transmission..... 29

    Safe driving..... 30  
**MAINTENANCE**..... 33  
    Engine oil level..... 34  
        Engine oil level check..... 34  
        Engine oil top-up..... 34  
        Warning light (insufficient oil pressure)..... 35  
        Engine oil change..... 35  
    Hub oil level..... 37  
    Tyres..... 38  
    Spark plug dismantlement..... 39  
    Removing the air filter..... 41  
    Air filter cleaning..... 41  
    Secondary air system..... 42  
    Cooling fluid level..... 43  
    Checking the brake oil level..... 44  
        Braking system fluid top up..... 45  
    Battery..... 46  
        Use of a new battery..... 47  
        Checking the electrolyte level..... 47  
    Long periods of inactivity..... 48  
    Fuses..... 49  
    Front light group..... 54  
        Headlight adjustment..... 55  
    Front direction indicators..... 55  
    Rear optical unit..... 55  
    Number plate light..... 56  
    Helmet compartment lighting bulb..... 57  
    Idle adjustment..... 57  
    Front and rear disc brake..... 58  
    Puncture..... 60  
    Periods of inactivity..... 61  
    Cleaning the vehicle..... 61  
**TECHNICAL DATA**..... 67

Kit equipment.....	72
<b>SPARE PARTS AND ACCESSORIES.....</b>	<b>75</b>
Warnings.....	76
<b>PROGRAMMED MAINTENANCE.....</b>	<b>79</b>
Scheduled maintenance table.....	80

# Beverly 125 - 250



**PIAGGIO®**



**Chap. 01  
Vehicle**

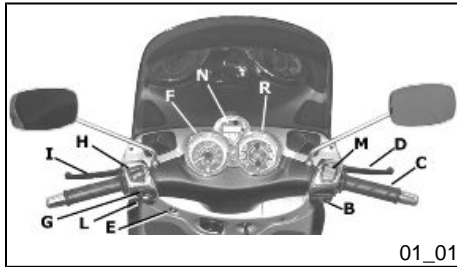

01\_01

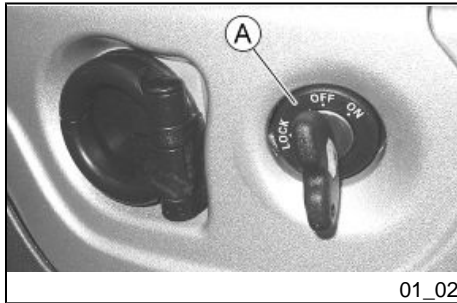

01\_02

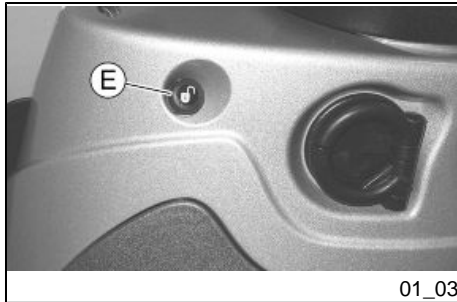

01\_03

## **Dashboard (01\_01, 01\_02, 01\_03)**

A = Key switch

B = Starter button

C = Throttle grip

D = Front brake lever

E = Electric seat opening button

F = Odometer and speedometer

G = Turn indicator switch

H = Light switch

I = Rear brake lever

L = Horn button

M = RUN OFF (immobiliser) switch

N = Digital clock

R = Instrument and warning lights panel



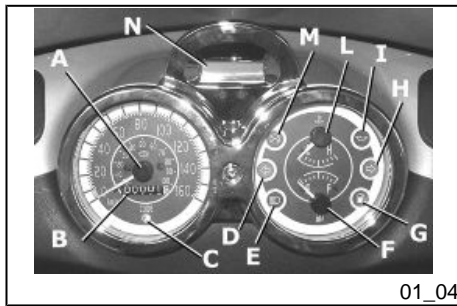

01\_04

## Analogue instrument panel (01\_04)

- A = Speedometer
- B = Odometer
- C = Immobilizer LED
- D = LH turn signal warning light
- E = High-beam warning light
- F = Fuel level gauge
- G = Low fuel warning light
- H = RH turn signal warning light
- I = Low oil pressure warning light
- L = Coolant temperature gauge
- M = Engine cut-off warning light
- N = Digital clock

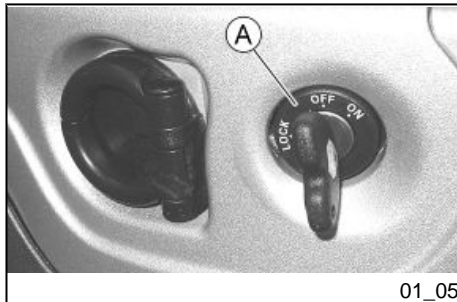

01\_05

## Key switch (01\_05)

- LOCK=** Ignition barred, key can be removed, mechanical antitheft device activated.
- OFF=** Ignition barred, key can be removed, mechanical antitheft device deactivated.
- ON=** Prestarting position, key cannot be removed, mechanical antitheft device deactivated.

## Locking the steering wheel

Turn the handlebar to the left (as far as it will go), turn the key to «**LOCK**» and remove the key.

### CAUTION



**DO NOT TURN THE KEY TO «LOCK» OR «OFF» WHILE RIDING.**

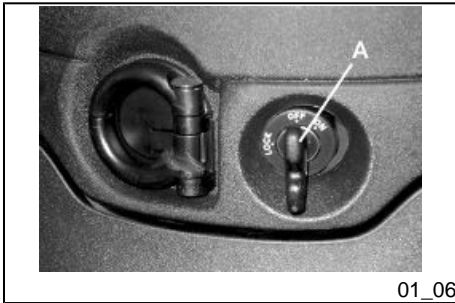

01\_06

## Releasing the steering wheel (01\_06)

Reinsert the key and turn it to «**OFF**».

### CAUTION



**DO NOT TURN THE KEY TO «LOCK» OR «OFF» WHILE RIDING.**

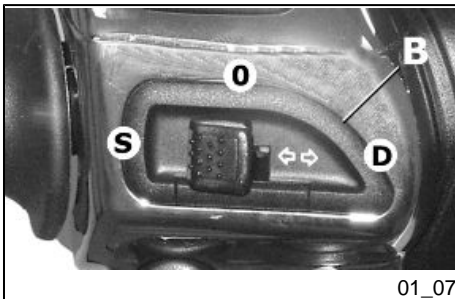

01\_07

## Switch direction indicators (01\_07)

Lever towards "**S**" = Left turn indicator is switched on;

Lever towards "**D**" = Right turn indicator is switched on;

The lever returns automatically to position "**0**" and the turn indicator "**B**" remains on; press the lever to turn them off.

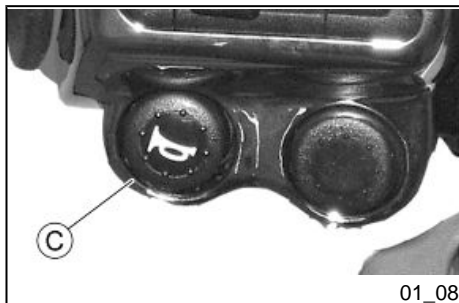

### Horn button (01\_08)

Push the «C» button to sound the horn.

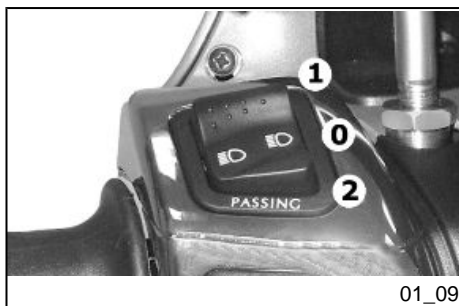

### Light switch (01\_09)

0 = Low-beam light

1 = High beam light

2 = Passing (flashing)



### Start-up button (01\_10)

Starter button "G"



### Engine stop button (01\_11)

0 = OFF

1 = RUN

### The immobilizer system

In order to enhance theft protection, the scooter is equipped with a **PIAGGIO IMMOBILIZER** » electronic engine locking device that is activated automatically when the starter key is removed. Upon start-up, the **PIAGGIO IMMOBILIZER** » system checks the starter key, and only if this key is recognised will the immobilizer system allow the scooter to be started.

## Keys (01\_12, 01\_13, 01\_14)

Two types of keys come with the vehicle. The red-handgrip key "A" is the "**MAS-TER**" key. Only a single copy of this key is supplied, which is necessary to program all your other keys and for your dealer to perform some maintenance operations. For this reason it is advised that it be used only in exceptional circumstances. The black key "B" (single copy supplied) is used for normal operations such as:

- engine start up
- glove-box opening

Together with the keys comes a CODE CARD which is imprinted with the mechanical code of the keys.

### WARNING



**LOSING THE RED KEY PREVENTS ANY REPAIRS OF THE 'PIAGGIO IMMOBILIZER' SYSTEM AND THE ENGINE CONTROL UNIT.**

### WARNING



**KEEP THE 'CODE CARD' AND THE RED HANDGRIP KEY IN A SAFE PLACE (NOT ON YOUR VEHICLE).**

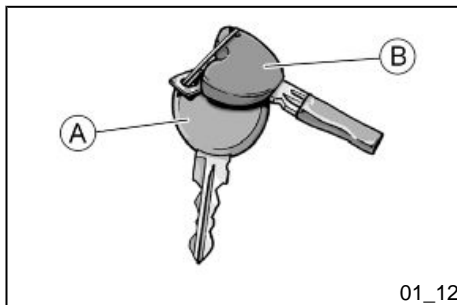

01\_12

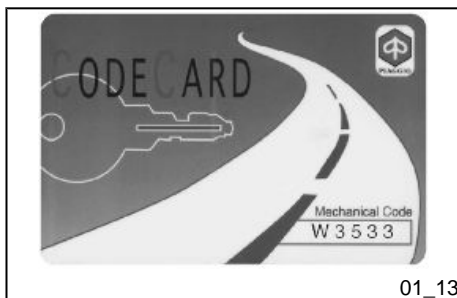

01\_13

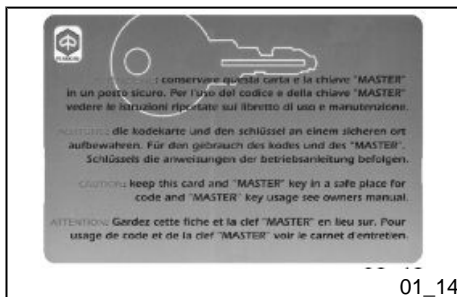

01\_14

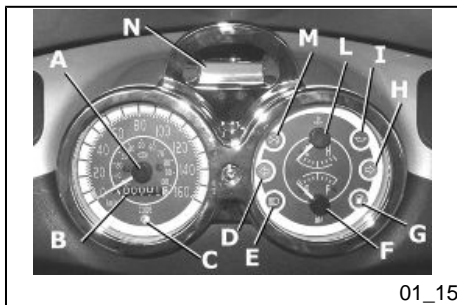

01\_15

## Immobilizerdevice enabled indicator led (01\_15)

Activation of the "PIAGGIO IMMOBILIZER" system is signalled by a flashing warning light "C" (see section "Analogue instrument panel").

In order to reduce battery discharge, the indicator LED turns off automatically after 48 hours of uninterrupted functioning.

Should the system fail, different LED flashing patterns will be provided by an **Authorised Piaggio-Gilera Service Centre** with information on the type of fault detected.

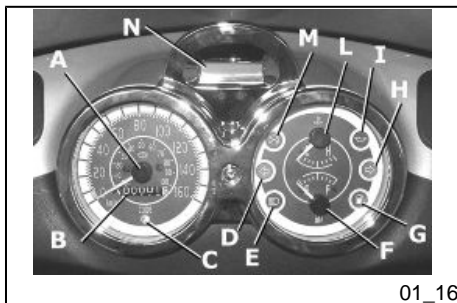

01\_16

## Operation (01\_16)

Every time the starter key is removed in the "OFF" or "LOCK" position, the safety system activates the immobilizer system. Turning the key to "ON" disables the engine lock, provided that the safety system recognises the code transmitted by the key. If the code is not recognised, turn the key first to "OFF" and then to "ON"; if the lock cannot be disabled, try with the other key supplied (red-coloured). If the engine cannot be started, contact an **Authorised Piaggio Service Centre**, which is provided with the electronic equipment required to detect and repair the system. The immobiliser is also activated in the engine is switched off with the RUN OFF switch. This happens even if the starter key is in position "ON".

When additional keys are required, please note that data storage (up to 3 keys max.) must be done on all keys, both new ones and existing ones. Take the key with the red grip and all the black keys supplied to an **Authorised Piaggio Service Centre**. The codes of keys not submitted for the new storage procedure are deleted from the memory. Any lost keys will therefore not be enabled to start the engine.

### WARNING



**EACH KEY HAS ITS OWN AND UNIQUE CODE, WHICH MUST BE STORED BY THE SYSTEM CONTROL UNIT.**

**VIOLENT SHOCKS MAY AFFECT THE ELECTRONIC COMPONENTS OF THE KEY.**

**IF OWNERSHIP OF THE VEHICLE IS TRANSFERRED, THE RED-HANDGRIP KEY (AS WELL AS THE OTHER KEYS) AND THE "CODE CARD" MUST ALSO BE TRANSFERRED TO THE NEW OWNER.**

## **Programming the immobilizer system**

In the following is described the procedure to follow to program the "**PIAGGIO IMMOBILIZER**" system and/or enter other keys in the memory.

### **Procedure start - red key**

Insert the red-handgrip key in the switch key (in "**OFF**" position) and turn it to "**ON**". After 1 - 3 seconds, turn the key to "**OFF**" again and pull it out.

### **Intermediate step - black key**

After pulling out the red key, insert the black key within 10 seconds and promptly turn it to "**ON**". After 1-3 seconds, turn the key to "**OFF**" again and pull it out. In this way, a maximum of 3 black keys can be programmed by repeating the above procedure keeping the indicated times.

### **Final step - red key**

After pulling out the last black key, insert the red key again and turn it to "**ON**" (this operation should be performed within 10 seconds of pulling out the previous key). Leave it in this position for 1 to 3 seconds and return it to the «**OFF**» position.

## Proper programming check

Insert the red key disabling the transponder (i.e., tilt the key cap by 90°) and turn the key to "ON". Perform the engine start-up operation. Ensure that the engine does not start. Insert the black key and repeat the start-up operation. Check that engine starts.

### WARNING

**SHOULD THE ENGINE START WITH THE RED KEY (WITH TRANSPONDER OFF), OR IN THE EVENT OF WRONG OPERATION DURING PROGRAMMING, REPEAT THE PROCEDURE FROM THE BEGINNING.**

## Accessing the fuel tank (01\_17, 01\_18)

Insert the key into the switch and press down until the glove box opens. In the event that the key switch is in «LOCK», turn the key to «OFF» or «ON» before pressing down. Press lever «B» and open the cover over the fuel tank cap «C».

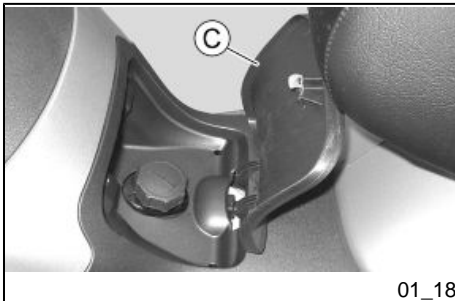
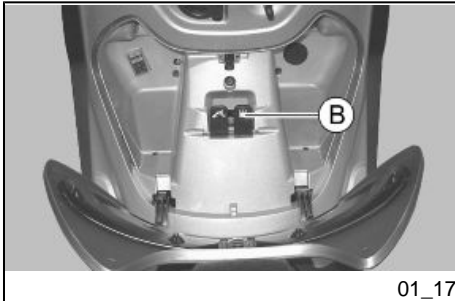



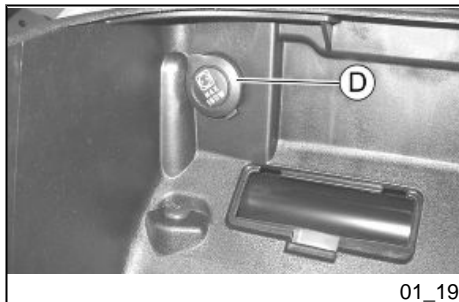

01\_19

## Power supply socket (01\_19)

There is a plug socket "D" inside the helmet compartment.

The plug socket may be used for external consumers (mobile phone, inspection light, etc.).

### CAUTION



**PROLONGED USE OF THE PLUG SOCKET MAY RESULT IN PARTIAL DISCHARGE OF THE BATTERY**

## Electric characteristic

### Plug socket

12 V - 180 W MAX

### Maximum power

180 W



01\_20

## The saddle (01\_20, 01\_21, 01\_22, 01\_23)

The saddle is supplied with a protection cover which may be used in case of rain. Lift the saddle and extract the cover from its housing. Fit it over the seat without pulling excessively to avoid tears and lower the seat again.

### CAUTION



**DO NOT USE THE VEHICLE WITHOUT THE PROTECTION COVER.**



01\_21

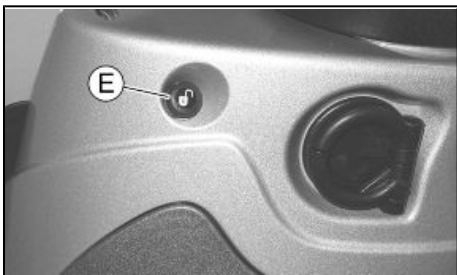

01\_22

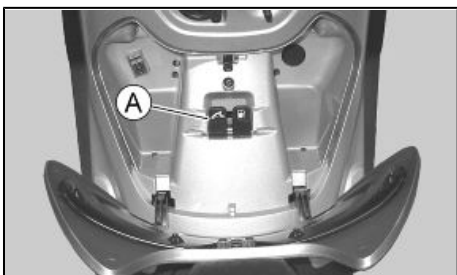

01\_23

## Opening the saddle

With the key in position "OFF" or "ON" or with the engine on, you can electrically open the saddle by pressing button "E". If the electric opening does not work, use the emergency lever "A". When the key is set to "LOCK" the saddle cannot be opened.

## Identification (01\_24, 01\_25)

The identification registration numbers consist of a prefix stamped on the chassis and engine "B" respectively, followed by a number. These numbers must always be indicated on spare parts requests. To read the chassis number, remove the relevant port "A" in the helmet compartment. We recommend checking that the chassis registration number stamped on the scooter corresponds with that on the scooter's documents.

### CAUTION



**BE REMINDED THAT ALTERING IDENTIFICATION REGISTRATION NUMBERS CAN LEAD TO SERIOUS PENAL SANCTIONS (IMPOUNDING OF THE VEHICLE, ETC.).**

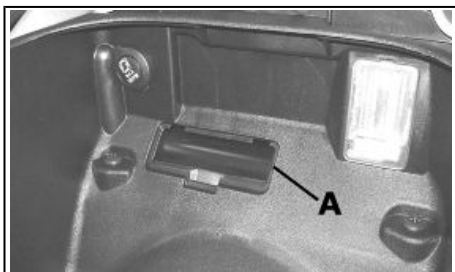

01\_24

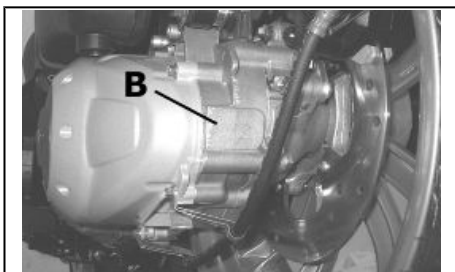

01\_25



01\_26



01\_27

## Helmet Anti-theft Device (01\_26, 01\_27)

Turn the key in anticlockwise direction and at the same time pulling out the retaining hook as far as it will go.

Insert the strap of the helmet inside the hook, then push the hook back inside the front rail of the luggage rack in order to avoid preventing starting.

### CAUTION



**IN ORDER TO AVOID ENDANGERING THE STABILITY WHEN RIDING, DO NOT RIDE THE SCOOTER WITH THE HELMET INSERTED INTO THE ANTITHEFT DEVICE.**

**N.B.**

**IN ORDER TO SIMPLIFY OPERATION WHILE INSERTING THE HOOK INTO THE RAIL, IT MAY BE NECESSARY - AS WHEN OPENING - TO TURN THE KEY IN ANTICLOCKWISE DIRECTION.**

**N.B.**

**THE SCOOTER IS EQUIPPED WITH A WATERPROOF BAG TO COVER THE HELMET WHEN IT IS FASTENED TO THE ANTITHEFT DEVICE TO BE USED IN THE EVENT OF RAIN.**

# Beverly 125 - 250



**PIAGGIO®**



**Chap. 02**  
**Use**

## Checks

Before using the vehicle, check:

1. That the fuel tank is full.
2. Front and rear brake fluid level
3. That the tyres are properly inflated.
4. The functioning of the tail lights, the headlight, and the turn indicators.
5. The functioning of the front and rear brakes.
6. The oil level in the gearcase.
7. The engine oil level.
8. The coolant level.

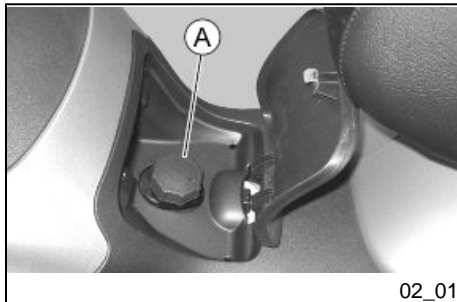

## Refuelling (02\_01, 02\_02)

**Fuel:** open the filler cap flap as described within the section «Accessing the fuel tank» and unscrew the filler cap, «A».

Recommended fuel:

Unleaded petrol, 95 octanes min.

The fuel level is indicated by the analogue gauge, «F».

### WARNING



**SWITCH OFF THE ENGINE BEFORE REFUELLING WITH PETROL.**

**PETROL IS HIGHLY INFLAMMABLE.**

**DO NOT SMOKE AND KEEP OPEN FLAMES AT A DISTANCE: FIRE HAZARD.**

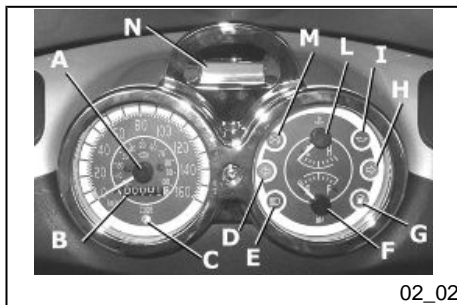

02\_02

**DO NOT INHALE FUEL FUMES.**

**DO NOT ALLOW PETROL TO COME INTO CONTACT WITH HOT ENGINE OR ANY PLASTIC PARTS.**

**CAUTION**



**PETROL DAMAGES THE PLASTIC PARTS OF THE BODYWORK.**

### Characteristic

#### **Fuel tank capacity**

9,8 litres (indicative value).

#### **Reserve**

Fuel reserve: 2 litres

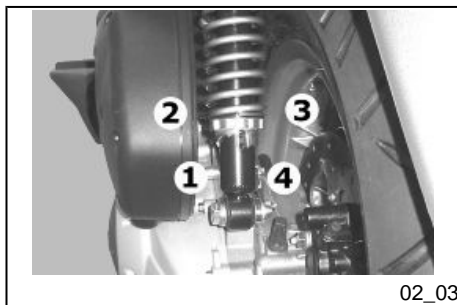

02\_03

### **Shock absorbers adjustment (02\_03)**

The preloading of the springs can be adjusted to 4 positions using the ring nut located in the lower part of the shock absorbers and the specific spanner supplied.

**Position 1:** minimum preload: driver only

**Position 2** medium preloading: driver only

**Position 3** medium preloading: rider and passenger

**Position 4:** maximum preloading: driver, passenger, and luggage.

In order to carry out this operation you will need to use the specific spanner in the kit.

**CAUTION**

**RIDING THE VEHICLE WITH THE SPRING PRELOADING NOT CORRECTLY SET FOR THE RIDER AND POSSIBLE PASSENGER, COULD REDUCE THE COMFORT OF THE RIDE AND THE PRECISION OF THE STEERING.**

**WARNING**

**WE RECOMMEND WEARING GLOVES WHILE CARRYING OUT THIS OPERATION IN ORDER TO AVOID INJURIES.**

**WARNING**

**WE STRONGLY RECOMMEND NOT TO ADJUST BOTH SHOCK ABSORBERS WITH DIFFERENT PRELOADING**

**Running in (02\_04)****WARNING**

**DURING THE FIRST 1000 KM DO NOT RIDE THE VEHICLE OVER 80% OF ITS MAXIMUM SPEED. AVOID TWISTING THE THROTTLE GRIP FULLY OR KEEPING A CONSTANT SPEED ALONG LONG SECTIONS OF ROAD. AFTER THE FIRST 1000 KM, GRADUALLY INCREASE SPEED UNTIL REACHING THE MAXIMUM PERFORMANCE.**





02\_05

## Starting up the engine (02\_05, 02\_06, 02\_07)

The vehicle is equipped with an engine cut-off system engaged by the side-stand. The engine cannot therefore be started if the side-stand is lowered. Likewise, if the engine is running, it will shut-down if the side-stand is lowered. The engine is fitted with automatic continuously variable transmission (CVT) and clutch. For this reason, the throttle must not be twisted while the engine is being started; to pull away from a still position, progressively increase the throttle opening. The vehicle is also equipped with a vacuum fuel pump and an electric choke device which are automatically engaged when the engine is running. In order to start the engine, pull either the right, «H», or left hand-side brake lever, «N», while pressing the engine starter button, «G», as this will disengage the starter safety switch.

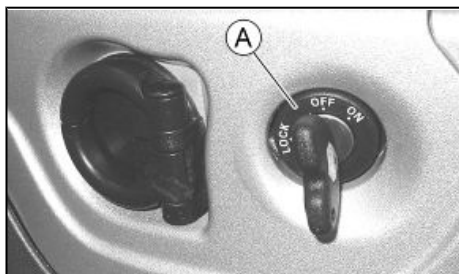

02\_06

1. Rest the vehicle on its centre-stand, «F», ensuring the rear wheel is not touching the ground.
2. Maintain the throttle grip, «M», completely untwisted.
3. Insert the key into the ignition key-switch, «A», and turn it onto the «ON» position.
4. Ensure the engine cut-off switch, «I», is set onto the «RUN» position and the side-stand, «L», is retracted.
5. Pull either the right, «H», or left hand-side brake lever, «N», while pressing the engine starter button «E».

### WARNING



**THE AUTOMATIC TRANSMISSION MAKES THE REAR WHEEL TURN EVEN WHEN THE THROTTLE IS SLIGHTLY TWISTED. RELEASE THE BRAKE CAREFULLY AFTER STARTING, AND THEN ACCELERATE GRADUALLY.**

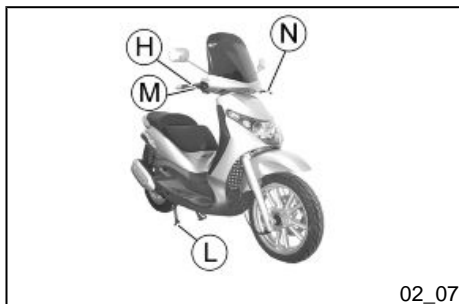

02\_07

#### CAUTION



**DO NOT START-UP THE ENGINE IN CLOSED AREAS BECAUSE EXHAUST GASES ARE TOXIC.**

### Precautions

#### CAUTION



**NEVER STRESS THE ENGINE AT LOW TEMPERATURES IN ORDER TO AVOID POSSIBLE DAMAGE. BE CAREFUL NEVER TO EXCEED THE MAXIMUM SPEED WHILE RUNNING DOWNHILL, IN ORDER TO AVOID DAMAGING THE ENGINE. IN ANY CASE, IN ORDER TO PRESERVE THE ENGINE FROM PROLONGED EXCESSIVE REVOLUTIONS, THE REVOLUTION LIMITER WILL BE ACTIVATED IF THE ENGINE SPEED EXCEEDS THE ESTABLISHED THRESHOLD.**

#### WARNING



**AFTER A LONG DISTANCE COVERED AT THE MAXIMUM SPEED, DO NOT STOP THE ENGINE IMMEDIATELY, BUT LET IT RUN AT IDLE FOR A FEW SECONDS.**



## Difficult start up (02\_08)

Should you experience starting difficulties, please proceed as follows:

**1. If the engine is flooded.** Carry out the operations indicated above. Twist the throttle fully and press the starter button, «G», while twisting the throttle for five seconds and maintaining it fully opened for another five seconds repeatedly; this alternated opening and closing operation allows more fuel to flow into the cylinder.

Should the engine fail to start after a few attempts, let it rest for a few minutes and repeat the above operations; please do not overstress the electric motor while attempting to start the engine.

As a last resort, remove the spark plug and crank the engine in order to expel the excessive fuel; hence refit the spark plug and repeat the previous operations from point 1.

**2. If the vehicle has run out of fuel.** After filling up the fuel tank, proceed to start the engine by pressing the starter button, «G», and maintaining the throttle completely untwisted, in order to increase the efficiency of the fuel pump.

**3. If the engine is hot.** Please follow the same operations while maintaining the throttle slightly open.

Should the vehicle fail to start after following the previous instructions, please contact your local **PIAGGIO Dealer or Authorised Service Station**.

A new starter system, fitted with an automatic valve-lift mechanism, has largely improved the efficiency of the starter motor.

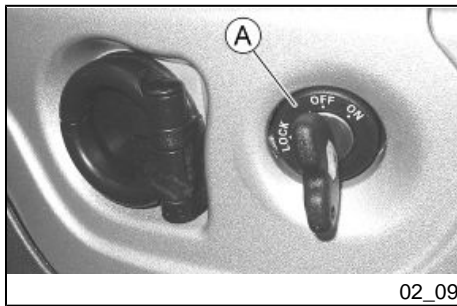

## Stopping the engine (02\_09)

Fully untwist the throttle grip, then rotate the key in the switch «A » to «KEY OFF» (extractable key).

### CAUTION



**DUE TO THE HIGH TEMPERATURES THE CATALYTIC CONVERTER CAN REACH, ALWAYS TAKE CARE, WHEN PARKING THE SCOOTER, THAT THE EXHAUST DOES NOT COME INTO CONTACT WITH FLAMMABLE MATERIALS, TO AVOID SERIOUS BURNS.**

### CAUTION



**DO NOT SWITCH OFF THE ENGINE WHILE THE VEHICLE IS MOVING. UN-BURNED FUEL COULD ENTER THE CATALYTIC CONVERTER AND BURN, CAUSING IT TO OVERHEAT AND POSSIBLY DESTROYING IT.**

### WARNING



**TO START AFTER A LONG STATIONARY PERIOD, OR IN SEVERE WEATHER CONDITIONS, FULLY TWIST THE THROTTLE 2-3 TIMES BEFORE PRESSING THE STARTER BUTTON.**

## Stand (02\_10)

### CENTRE STAND

Push with your foot on the centre stand's fork «F» while lifting the vehicle backward, holding onto the handlebar.



02\_10

### **SIDE STAND**

Push with your foot on the fork of the stand "L" to bring it into the open position while lifting the scooter at the same time.

### **CAUTION**



**TAMPERING MAY CAUSE SERIOUS ENGINE MALFUNCTION.**

### **WARNING**



**THE SIDE STAND CAUSES THE ENGINE TO TURN ITSELF OFF WHENEVER IT IS LOWERED.**

### **Automatic transmission (02\_11)**

To ensure simple, pleasurable riding, the vehicle is equipped with automatic transmission with regulator and centrifugal clutch. The system is designed to provide the best performance (acceleration and consumption) while riding on both flat roads and uphill.

If you have to stop on an uphill slope (traffic lights, traffic jam, etc.) **use only the brake to keep the vehicle still, leaving the engine running at idle speed. Using the engine to keep the vehicle still can cause the clutch to overheat, due to the friction of the clutch mechanism itself against the clutch bell.**



02\_11

It is therefore recommended to avoid conditions of prolonged clutch slippage (other than those previously indicated) like driving uphill fully laden on steep slopes or starting off with driver and passenger at slopes with steepness greater than 25%.

Observe the following precautions if the clutch overheats:

1. Do not continue riding in such conditions.
2. Let the clutch cool down with the engine at idle speed for a few minutes.



### **Safe driving (02\_12)**

Some simple tips are provided below that will enable you to use your vehicle on a daily basis in greater safety and peace of mind. Your skill and your mechanical knowledge are the basis of safe riding. We recommend trying out the vehicle in traffic - free zones, in order to acquire a good knowledge of the vehicle it self.

1. Before riding off, remember to put on your helmet and fasten it correctly.
2. Reduce speed on rough roads and drive with care.
3. After riding on a long stretch of wet road without using the brakes, braking can be poor at the beginning. Given these conditions, it is a good idea to operate the brakes from time to time.
4. Do not brake hard on wet, dirt or slippery road surfaces.
5. Avoid riding off by mounting the scooter when resting on the support. In any case, the rear wheel should not be turning when it comes into contact with the ground, in order to avoid abrupt departures.
6. When riding along roads covered by sand, mud, snow mixed with salt, etc. we recommend cleaning the brake disc frequently with a non-corrosive detergent in order to prevent corrosive particles from building up in the holes, which may cause early brake pad wear.

**CAUTION**

**ALWAYS RIDE WITHIN YOUR LIMITS RIDING UNDER THE INFLUENCE OF ALCOHOL OR OTHER DRUGS AND CERTAIN MEDICATIONS IS EXTREMELY DANGEROUS.**

**CAUTION**

**ANY CHANGES TO THE VEHICLE PERFORMANCE AS WELL AS ALTERATIONS TO ORIGINAL STRUCTURAL PARTS IS STRICTLY FORBIDDEN BY LAW, AND RENDERS THE VEHICLE NO LONGER CONFORMING TO THE APPROVED TYPE AND DANGEROUS FOR RIDING.**

**CAUTION**

**DO NOT ADJUST THE MIRRORS WHILE RIDING. THIS COULD CAUSE YOU TO LOOSE CONTROL OF THE VEHICLE.**

**WARNING**

**IN ORDER TO PREVENT ANY ACCIDENTS RIDE VERY CAREFULLY AFTER ADDING ACCESSORIES AND WHILE CARRYING LUGGAGE. THE ADDITION OF ACCESSORIES AND LUGGAGE CAN REDUCE YOUR SCOOTER STABILITY AND PERFORMANCE, AS WELL AS THE LEVEL OF SAFETY DURING USE. NEVER DRIVE THE SCOOTER EQUIPPED WITH ACCESSORIES AT A SPEED HIGHER THAN 100 km/h (see section "SPARE PARTS AND ACCESSORIES")**





# Beverly 125 - 250



**PIAGGIO®**



**Chap. 03  
Maintenance**

## Engine oil level

In 4T engines, the engine oil is used to lubricate the distribution elements, the bench bearings and the thermal group. **An insufficient quantity of oil can cause serious damage to the engine.** In all four-stroke engines, a loss of efficiency in oil performance and consumption should be considered normal. Consumption can particularly reflect the conditions of use (i.e. when driving at 'full acceleration' all the time, oil consumption increases). **In order to prevent any problems, we recommend checking the oil level any time you use the vehicle. The scooter is, however, equipped with an oil pressure warning light on the instrument panel.**

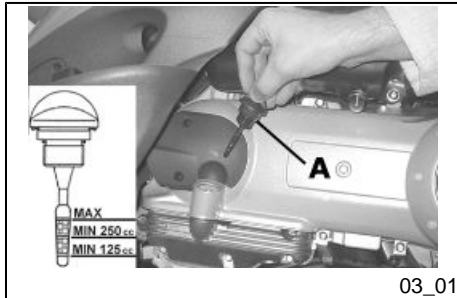

### Engine oil level check (03\_01)

Every time the vehicle is used, visually inspect the level of the engine oil when the engine is cold (after **completely unscrewing** the oil cap/dipstick). The oil level should be somewhere between the MAX and MIN index marks on the level rod: «**A**»; during the oil check, the vehicle must be resting on its centre stand on an even, horizontal surface.

If the check is carried out after the vehicle has been used, and therefore with a hot engine, the level line will be lower; in order to carry out a correct check, wait at least 10 minutes after the engine has been stopped so as to get the correct level.

### Engine oil top-up

Any topping up with oil must be carried out after the oil level check by adding oil, but **never exceeding the MAX level.** The topping up of the level between **MIN** and **MAX** requires approx. **200 cc** of oil. Every 5000 km, however, the engine oil level should be checked and topped up, if necessary, at an **Authorised Piaggio Service Centre.**

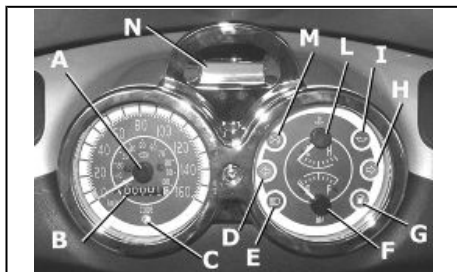

03\_02

### Warning light (insufficient oil pressure) (03\_02)

The scooter is equipped with a warning light "I" that lights up when the key is turned to the "ON" position.

However, this light should switch off once the engine has been started.

**If the light comes on during braking, at idling speed or while turning a corner, it is necessary to check the oil level and top-up if required. If after having topped up the oil, the warning light still turns on while braking, at idle speed or while turning a corner, it will be necessary to turn to an Authorised Service Centre.**

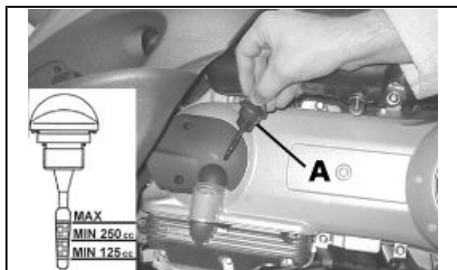

03\_03

### Engine oil change (03\_03, 03\_04)

The oil and cartridge filter «C» should be replaced every 6,000 km (125 cc) or 12,000 Km (250 cc) at an **Authorized Piaggio Service Centre**. The engine should be emptied by draining the oil from the filter drainage tap «B» on the flywheel side. In order to facilitate the oil drainage, loosen the cap/bar. Since a certain quantity of oil remains in the circuit still, the fill-up should be carried out with around 600 ÷ 650 cc of oil from cap «A». Then start up the vehicle, leave it running for a few minutes and switch it off: after around 5 minutes, check the level and top up if necessary **without ever exceeding the MAX level**. The cartridge filter should be replaced every time the oil is changed. For top ups and replacements use new oil of the recommended type.

#### WARNING



**RUNNING THE ENGINE WITH INSUFFICIENT LUBRICATION OR WITH INADEQUATE LUBRICANTS ACCELERATES THE WEAR AND TEAR OF THE MOVING PARTS AND CAN CAUSE IRRETRIEVABLE DAMAGE.**

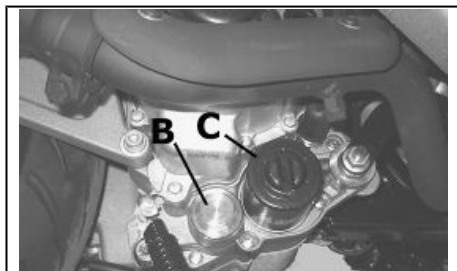

03\_04

**WARNING**



**EXCESSIVE OIL LEVEL AT TOP-UPS CAN LEAD TO SCALE FORMATION AND VEHICLE MALFUNCTION.**

**CAUTION**



**USED OILS CONTAIN SUBSTANCES HARMFUL TO THE ENVIRONMENT. FOR OIL CHANGE, CONTACT AN AUTHORISED PIAGGIO SERVICE CENTRE, AS THEY ARE EQUIPPED TO DISPOSE OF USED OILS IN AN ENVIRONMENTALLY FRIENDLY AND LEGAL WAY.**

**CAUTION**



**USING OILS OTHER THAN THOSE RECOMMENDED CAN SHORTEN THE LIFE OF THE ENGINE.**

**Recommended products**

**AGIP CITY HI TEC 4T**

*Engine oil*

SAE 5W-40, API SL, ACEA A3, JASO MA Synthetic oil

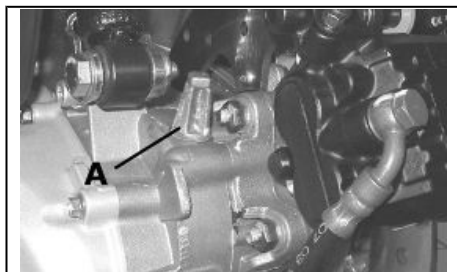

03\_05

### Hub oil level (03\_05, 03\_06)

Check the oil in the rear hub.

To check the rear hub oil level, proceed as follows:

- 1) Park the scooter on level ground and place it on the centre stand.
- 2) Unscrew the dipstick "A", dry it with a clean rag and then reinsert it, **screwing it tightly into place**;
- 3) Remove the dipstick and check that the oil level is above the first notch from the bottom.
- 4) Screw the dipstick back in, checking that it is locked in place.

#### N.B.

THE REFERENCE MARKS ON THE HUB OIL LEVEL DIPSTICK, EXCEPT FOR THE ONE INDICATING THE "MAX" LEVEL, REFER TO OTHER MODELS BY THE MANUFACTURER AND HAVE NO SPECIFIC FUNCTION FOR THIS MODEL.

#### CAUTION



RIDING THE VEHICLE WITH INSUFFICIENT HUB LUBRICATION OR WITH CONTAMINATED OR IMPROPER LUBRICANTS ACCELERATES THE WEAR AND TEAR OF THE MOVING PARTS AND CAN CAUSE SERIOUS DAMAGE.

#### CAUTION



USED OILS CONTAIN SUBSTANCES HARMFUL TO THE ENVIRONMENT. FOR OIL REPLACEMENT, CONTACT AN AUTHORISED SERVICE CENTRE, WHICH IS EQUIPPED TO DISPOSE OF USED OILS IN AN ENVIRONMENTALLY FRIENDLY AND LEGAL WAY.

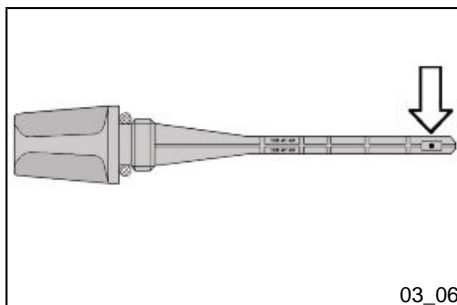

03\_06

**CAUTION**

**UPON REPLACING HUB OIL, AVOID THE OIL COMING INTO CONTACT WITH THE REAR BRAKE DISC.**

**Recommended products**

**AGIP ROTRA 80W-90**

*Rear hub oil*

SAE 80W/90 Oil that exceeds the requirements of API GL3 specifications

**Characteristic**

**Rear hub oil**

250 cc

**Tyres (03\_07)**

Check periodically (about every 500 km) the tyre pressure. The tyres are equipped with wear indicators; the tyres should be replaced as soon as these indicators become visible on the tyre tread. Also check that the tyres do not show signs of splitting at the side or irregular tread wear; if this occurs, go to an authorised workshop or at least to a workshop equipped to perform the replacement.

**CAUTION**

**TYRE PRESSURE SHOULD BE CHECKED WHEN TYRES ARE COLD. INCORRECT TYRE PRESSURE CAUSES ABNORMAL TYRE WEAR AND MAKES RIDING DANGEROUS.**

**TYRES MUST BE REPLACED WHEN THE TREAD REACHES THE WEAR LIMITS SET FORTH BY LAW.**

### **Characteristic**

#### **Tyre pressure (front wheel)**

Front wheel: 2.1 bar

#### **Tyre pressure (rear wheel)**

Rear wheel: 2.3 bar

#### **Tyre pressure (rear wheel with rider and passenger)**

Rear wheel (rider and passenger) 2.5 bar

### **Spark plug dismantlement (03\_08, 03\_09)**

Proceed as follows:

1. Remove the spark-plug access door, on the RHS fairing, and use your hand to reach out for the spark-plug;
2. Detach the spark-plug cap, «A»;
3. Use the supplied box-spanner to loosen the spark-plug;
4. Refit the spark-plug by screwing it in by hand, with the correct inclination;
5. The box-spanner should only be used to tighten the spark-plug;
6. Carefully refit the spark-plug cap, «A».

#### **N.B.**

**THE USE OF SPARK PLUGS OTHER THAN THE INDICATED TYPE OR OF SHIELDLESS SPARK PLUG CAPS CAN CAUSE ELECTRICAL SYSTEM FAILURES.**

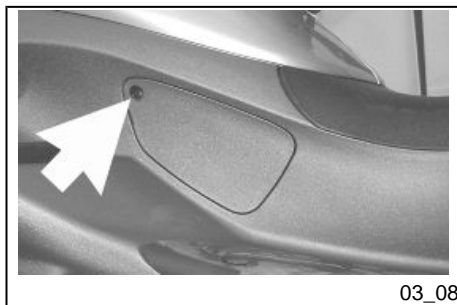

03\_08

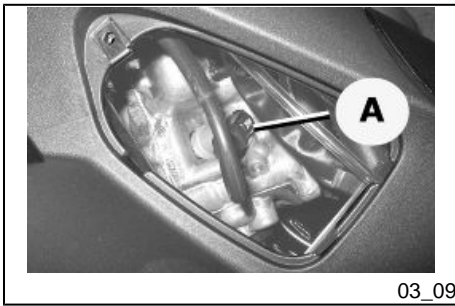
**WARNING**

THE SPARK PLUG MUST BE REMOVED WHEN THE ENGINE IS COLD. THE SPARK PLUG SHOULD BE CHECKED EVERY 6,000 KM AND CHANGED EVERY 12,000 KM. THE USE OF ELECTRONIC CENTRAL UNITS OR ELECTRONIC IGNITIONS DIFFERING FROM THOSE RECOMMENDED CAN SERIOUSLY DAMAGE THE ENGINE. IF THE REMOVAL OF THE SPARK PLUG IS ATTEMPTED AFTER FLOODING THE ENGINE (EXPULSION OF EXCESS FUEL IN THE SECTION «SAFE RIDING»), IT IS RECOMMENDED THAT THE SMALL PIPE TO THE SPARK PLUG IS KEPT CONNECTED AND THE LATTER IS IN CONTACT WITH A GROUND FAR FROM THE SPARK PLUG HOLE ITSELF IN ORDER TO AVOID THE EXPELLED FUEL CATCHING ON FIRE.

**Characteristic**

**Recommended spark plugs 125cc**

NGK CR8EB

**Recommended spark plug 250cc**

CHAMPION RG4HC

**Electrode gap**

0.7-0.8 mm



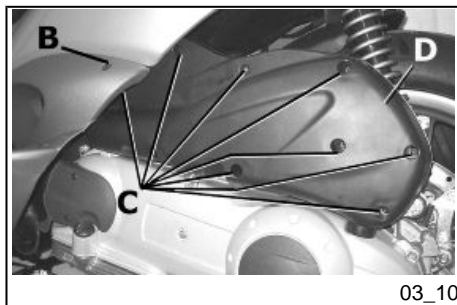

## Removing the air filter (03\_10)

Proceed as follows:

1. Remove screw "B"
2. Remove retaining screws "C" and remove the cover "D" of the air filter.

## Air filter cleaning

1. Wash the sponge with water and neutral soap.
2. Dry it with a clean cloth and small blasts of compressed air.
3. Impregnate the sponge with a mixture of 50% petrol and 50% specified oil.
4. Gently squeeze the filter element, let it drip and then refit it.

### CAUTION



**IF THE VEHICLE IS USED ON DUSTY ROADS, IT IS NECESSARY TO SERVICE THE AIR FILTER MORE OFTEN TO AVOID DAMAGING THE ENGINE.**

## Recommended products

### AGIP FILTER OIL

*Oil for air filter sponge*

Mineral oil with specific additives for increased adhesiveness

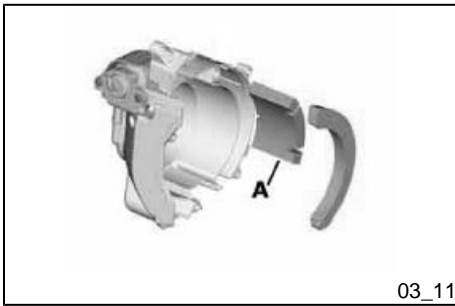

## Secondary air system (03\_11, 03\_12, 03\_13)

In order to reduce polluting emissions, the vehicle is equipped with a catalytic converter.

The catalysis is aided by the admission of fresh air, depurated through the Secondary Air System (SAS), inside the exhaust duct directly on the cylinder head.

Such system provides an addition of oxygen to the unburnt gases before entering the catalytic converter, thus allowing for improved process effectiveness.

Irregular noises are prevented, by the presence of a control valve which by-passes the SAS while the vehicle is decelerating.

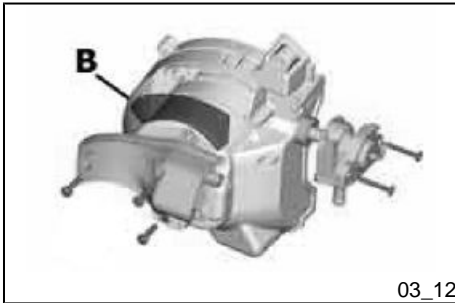

In order to preserve the SAS, so to ensure its efficiency, the following maintenance procedures should be carried out by and **Authorised Piaggio Service Station**:

**125cc Engine** - For this engine, the system consists of an internal, «A» and an external filter, «B». These should be cleaned every two years.

**250cc Engine** - This system features a single filter, «A» positioned inside the plastic box, externally mounted onto the transmission cover. Cleaning is scheduled for every 12,000 Km.

The sponge filters should be cleaned with water and soap, and then dried with a clean cloth and light jets of compressed air.

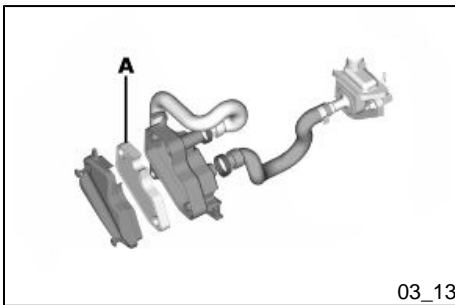

### Cooling fluid level (03\_14, 03\_15, 03\_16)

The engine cooling system is of the liquid type with a circuit capacity of approximately 1.8 litres and the coolant constitutes of a 50% mixture of demineralised water and anti-freeze glycol-ethylene-based solution with corrosion inhibiting agents. The supplied coolant is pre-mixed and ready for use. For the engine to be running properly, the coolant temperature should be maintained within the central portion of the instrument's scale, «L».

If the pointer enters into the red zone, stop the engine, let it cool down and check the fluid level; if the result is normal, turn to an Authorized Piaggio Service Centre. The fluid inspection should be carried out every 6,000 km when the motor is cold, following the methods indicated below.

- a) Place the vehicle in a vertical position on the support.
- b) Remove the plug from expansion tank «A» by turning it counter clockwise.
- c) Look into the expansion tank: a mark in the plastic indicates the maximum and minimum reference of the expansion tank.
- d) Top up the cooling fluid if the fluid level is below the minimum level margin inside the expansion tank. The fluid level should always be between the min. level and max. level. If the fluid is near the minimum level, proceed with the top-up operation to be carried out when the engine is cold.

If it is necessary to top up the cooling fluid frequently, or if the expansion tank is completely dry, you should look for the cause in the cooling system. It is therefore indispensable to have the cooling system checked at an **Authorized Piaggio Service Centre**.

The cooling fluid should be replaced every 2 years. Turn to an Authorized **Piaggio Service Centre for this operation**.

**N.B.**

**IF DURING A NON-DEMANDING RIDE THE COOLANT WARNING LIGHT COMES ON, SHUT OFF THE ENGINE AND ALLOW IT TO COOL DOWN. THEN CHECK THE COOLANT LEVEL; IF THE LEVEL IS NOT CORRECT, CONTACT AN AUTHORISED SERVICE CENTRE.**



03\_14

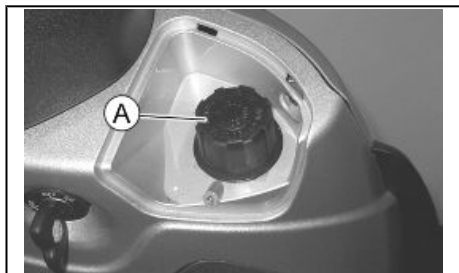

03\_15

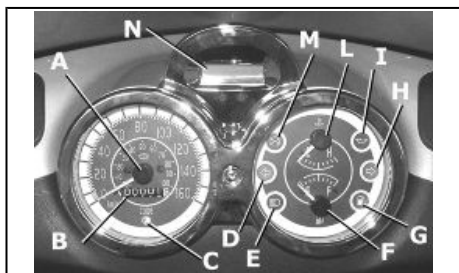

03\_16

**WARNING**

**TO AVOID THE RISK OF SCALDING, DO NOT UNSCREW THE EXPANSION TANK COVER WHILE THE ENGINE IS STILL HOT.**

**WARNING**

**IN ORDER TO AVOID HARMFUL FLUID LEAKS WHILE RIDING, IT IS IMPORTANT TO MAKE SURE THAT THE LEVEL NEVER EXCEEDS THE MAXIMUM VALUE.**

**IN ORDER TO GUARANTEE THE PROPER FUNCTION OF THE ENGINE, IT IS NECESSARY TO KEEP THE RADIATOR GRILLE CLEAN.**

**Recommended products****AGIP PERMANENT SPEZIAL***coolant*

Monoethylene glycol-based antifreeze fluid, CUNA NC 956-16

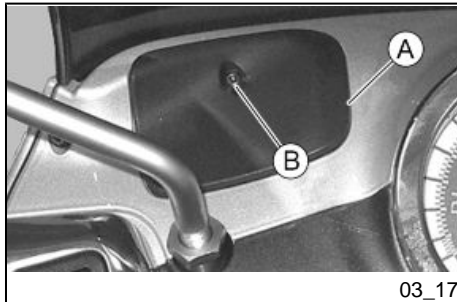
**Checking the brake oil level (03\_17, 03\_18)**

The brake fluid tanks of the front and rear brakes are located on the pumps under the covers on the handlebar. Proceed as follows:

1. Place the scooter on its centre stand and make sure the handlebar is centred;
2. Remove cover "A" by removing the respective retaining screw "B";
3. Check the fluid level through the respective sight glass "C".

A certain lowering of the level is caused by wear on the pads. Should the level appear to be below the minimum mark, please contact your nearest **PIAGGIO Dealer or Au-**

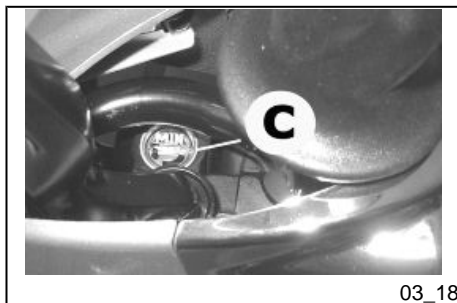

03\_18

**thorised Service Centre** in order to have a thorough inspection of the brake system carried out.

### Braking system fluid top up

Proceed as follows:

Remove tank covers "A" and loosen the two screws and top up the brake fluid level using only the prescribed brake fluid and without exceeding the maximum level.

Under normal climatic conditions, the brake fluid must be replaced every 20,000 km or every two years, whichever comes first. This operation must be carried out by trained technicians; please contact your nearest **PIAGGIO Dealer or Authorised Service Centre**.

#### WARNING



**ONLY USE DOT 4 CLASS BRAKE FLUIDS. COOLING SYSTEM FLUIDS ARE HIGHLY CORROSIVE. MAKE SURE THAT IT DOES NOT COME INTO CONTACT WITH THE PAINTWORK**

#### CAUTION



**AVOID CONTACT OF BRAKE FLUID WITH EYES, SKIN, AND CLOTHING. IN CASE OF CONTACT, RINSE WITH WATER. THE BRAKING CIRCUIT FLUID IS**

**HYGROSCOPIC, THAT IS, IT ABSORBS HUMIDITY FROM THE SURROUNDING AIR. IF THE HUMIDITY IN THE BRAKING FLUID EXCEEDS A CERTAIN VALUE, IT WILL LEAD TO INEFFICIENT BRAKING. NEVER USE BRAKING FLUID KEPT IN CONTAINERS THAT HAVE ALREADY BEEN OPENED, OR PARTIALLY USED.**

### **Recommended products**

#### **AGIP BRAKE 4**

*Brake fluid*

FMVSS DOT 4 Synthetic fluid

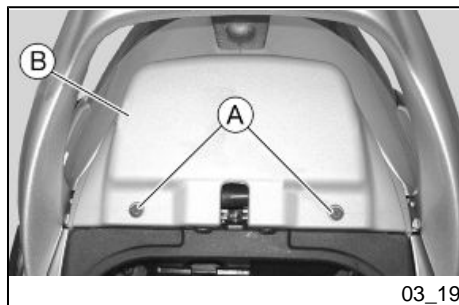

03\_19

### **Battery (03\_19, 03\_20)**

To access the battery, proceed as follows:

1. Place the scooter on its centre stand;
2. Open the saddle, following the procedure described above, see section "Opening the saddle to reach the helmet compartment";
3. Remove retainers "A" and cover "B".

The battery is the electrical device that requires the most frequent inspections and diligent maintenance. The main points of maintenance to be observed are as follows:

#### **CAUTION**



**IN ORDER TO AVOID DAMAGING THE ELECTRICAL SYSTEM, NEVER DISCONNECT THE WIRING WHILE THE ENGINE IS RUNNING. DO NOT TIP THE SCOOTER TOO MUCH IN ORDER TO AVOID DANGEROUS LEAKAGE OF BATTERY ELECTROLYTE**

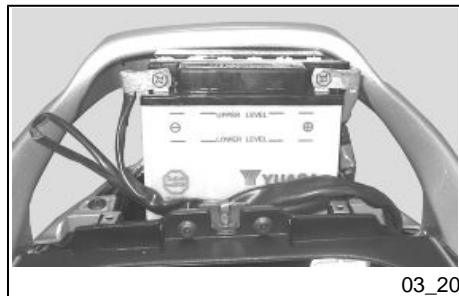

03\_20

## Use of a new battery

Make sure that the terminals are connected correctly.

### CAUTION



**DO NOT REVERSE THE POLARITY: RISK OF SHORT CIRCUIT AND DAMAGE TO THE ELECTRICAL SYSTEM.**

### WARNING



**SPENT BATTERIES ARE HARMFUL FOR THE ENVIRONMENT. COLLECTION AND DISPOSAL SHOULD BE CARRIED OUT IN COMPLIANCE WITH CURRENT REGULATIONS.**

## Checking the electrolyte level

The electrolyte level, which should be checked regularly, must always be at the maximum level. To reach this level, use only distilled water. Should it become necessary to top up the battery with water too frequently, check the scooter's electrical system because the battery is being overloaded, causing it to lose power quickly.

### CAUTION



**ELECTROLYTE CONTAINS SULPHURIC ACID: AVOID CONTACT WITH EYES, SKIN AND CLOTHES. IN THE CASE OF ACCIDENTAL CONTACT, RINSE WITH ABUNDANT OF WATER AND CONSULT A DOCTOR.**

## Long periods of inactivity

Battery performance will decrease if the vehicle is not used for a long time. This is the result of the natural phenomenon of battery discharging plus residual absorption by vehicle components with constant power consumption. Poor battery performance may also be due to environmental conditions and the cleanness of the poles. In order to avoid difficult starts and/or irreversible damage to the battery, follow any of these steps:

- **At least once a month** start the engine and run it slightly above idle speed for 10-15 minutes. This keeps all the engine components, as well as the battery, in good working order.

- Take your vehicle to a garage (as indicated in the "Vehicle not used for extended periods" section) to have the battery removed. Have the battery cleaned, charged fully and stored in a dry, ventilated place. Recharge **at least once every two months**.

### **N.B.**

**THE BATTERY MUST BE CHARGED WITH A CURRENT EQUAL TO 1/10 OF THE RATED CAPACITY OF THE BATTERY AND FOR NOT LONGER THAN 10 HOURS. CONTACT AN AUTHORISED SERVICE CENTRE TO CARRY OUT THIS OPERATION SAFELY. WHEN REFITTING THE BATTERY MAKE SURE THE LEADS ARE CORRECTLY CONNECTED TO THE TERMINALS.**

### **WARNING**



**DO NOT DISCONNECT THE BATTERY CABLES WITH THE ENGINE RUNNING, THIS CAN CAUSE PERMANENT DAMAGE TO THE VEHICLE ELECTRONIC CONTROL UNIT.**



**WARNING**

**SPENT BATTERIES ARE HARMFUL FOR THE ENVIRONMENT. COLLECTION AND DISPOSAL SHOULD BE CARRIED OUT IN COMPLIANCE WITH CURRENT REGULATIONS.**

**Fuses (03\_21, 03\_22, 03\_23)**

To access the fuse holder, «**A**», remove the fixing screw, «**B**», and the mouldings. The electrical system comprises of:

1. Four safety fuses, «**A**»,.
2. Four safety fuses, «**B**», for the protection of the various circuits, placed inside the glove-box, on the left hand-side.

The tables show the location and rating of the fuses on the vehicle.

**CAUTION**

**BEFORE REPLACING A BLOWN FUSE, FIND AND SOLVE THE FAILURE THAT CAUSED IT TO BLOW. NEVER TRY TO REPLACE THE FUSE WITH ANY OTHER MATERIAL (E.G., A PIECE OF ELECTRIC WIRE).**

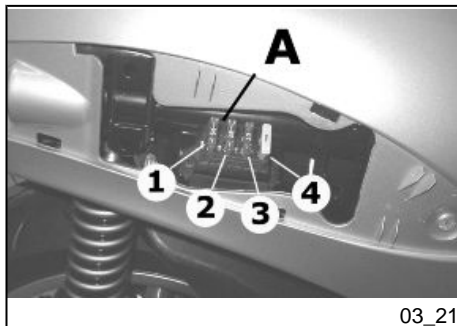

03\_21

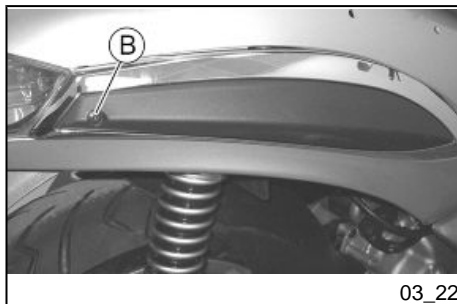

03\_22

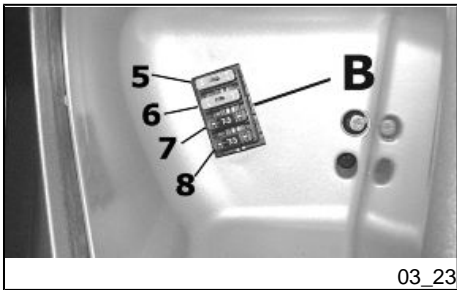

03\_23

## **FUSE TABLE**

Fuse no. 1

**Position on fuse holder:** 1

**Rating:** 15A

**Protected circuits:** Radiator electric fan - Battery recharging circuit - Vehicle's lights - Ignition - Electrical lines protected by fuses 4, 5, 6, 7, and 8

**Location:** Right hand-side bay

Fuse no. 2

**Position on fuse holder:** 2

**Rating:** 15A

**Protected circuits:** 12V-180W Socket for electrical devices - Helmet compartment courtesy light - Electrical seat opening

**Location:** Glove-box

Fuse no. 3                    **Position on fuse holder: 3**  
**Rating:** 10A  
**Protected circuits:** High and low beam lights - Head and tail lights - License plate light - Circuit protected by fuse no. 4  
**Location:** Right hand-side bay

Fuse no. 4                    **Position on fuse holder: 4**  
**Rating:** 10A  
**Protected circuits:** Clock - Radio/intercom - Immobiliser blinker (LED)  
**Location:** Right hand-side bay

Fuse no. 5                    **Position on fuse holder:5**  
**Rating:** 7,5A  
**Protected circuits:** Radio/interphone master-box pre-wiring voltage supply - Flash light  
**Location:** Glove-box

Fuse no. 6                    **Position on fuse holder:6**  
**Rating:** 7,5A  
**Protected circuits:** Warning lights power supply - Coolant temperature and fuel level gauges.  
**Location:** Glove-box

Fuse no. 7                    **Position on fuse holder:7**

**Rating:** 4A**Protected circuits:** Stop light -  
Starting safety switch**Location:** Glove-box

Fuse no. 8

**Position on fuse holder:**8**Rating:** 4A**Protected circuits:** Headlight bulb  
- Taillight bulb - Horn - Dashboard  
lighting - License plate light**Location:** Glove-box

### **LIGHT BULB TABLE**

High-beam light bulb

**Type:** HALOGEN (H7)**Power:** 12V - 55W**Quantity:** 1

Low-beam bulb

**Type:** HALOGEN (H1)**Power:** 12V - 55W**Quantity:** 1

Front tail light bulb

**Type:** ALL GLASS**Power:** 12V - 5W

	<b>Quantity: 2</b>
Instrument panel bulb	<b>Type:</b> ALL GLASS <b>Power:</b> 12V - 2W <b>Quantity:</b> 5
Front turn indicator bulb	<b>Type:</b> Spherical <b>Power:</b> 12V - 10W <b>Quantity:</b> 1 RHS + 1 LHS
Helmet compartment light bulb	<b>Type:</b> CYLINDRIC <b>Power:</b> 12V - 5W <b>Quantity:</b> 1
Rear turn indicator light bulb	<b>Type:</b> Spherical <b>Power:</b> 12V - 10W <b>Quantity:</b> 1 RHS + 1 LHS
Taillight bulb	<b>Type:</b> SPHERICAL <b>Power:</b> 12V - 3W <b>Quantity:</b> 2
Stop light bulb	<b>Type:</b> ALL GLASS <b>Power:</b> 12V - 10W <b>Quantity:</b> 1
License plate light bulb	<b>Type:</b> ALL GLASS <b>Power:</b> 12V - 5W

Quantity: 1

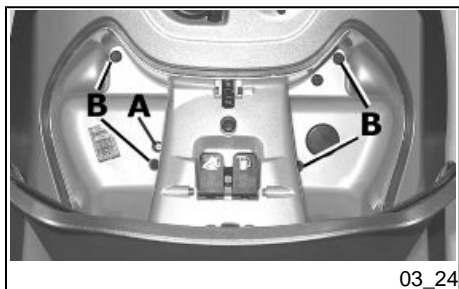

03\_24

### Front light group (03\_24)

To remove the rear light assembly, proceed as follows:

1. Remove the four screws "B".
2. Remove the light assembly from its seat and proceed to replace the blown bulb.

To reassemble, repeat the operation in the reverse order.

#### WARNING



**HIGH AND LOW BEAM LIGHT ARE OF THE HALOGEN TYPE: DO NOT TOUCH WITH YOUR FINGERS TO AVOID DAMAGING THEIR FUNCTION.**

#### N.B.

**IF MISTING IS NOTICED ON THE INSIDE OF THE HEADLAMP GLASS, THIS DOES NOT INDICATE A FAULT AND IS RELATED TO THE HUMIDITY AND/OR TO LOW TEMPERATURES.**

**THE PHENOMENON SHOULD QUICKLY DISAPPEAR WHEN THE LIGHT IS SWITCHED ON.**

**THE PRESENCE OF DROPS OF WATER, ON THE OTHER HAND, COULD INDICATE THAT WATER IS INFILTRATING. CONTACT THE PIAGGIO AFTER-SALES SERVICE NETWORK.**

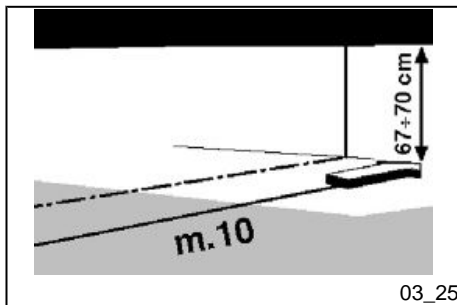

03\_25

### Headlight adjustment (03\_25)

Proceed as follows:

1. Place the scooter in riding condition, unloaded, with the tyres correctly inflated, on a flat piece of ground at a distance of 10 m from a white screen situated in a shaded area, making sure that the scooter is perpendicular to the screen;
2. Draw a horizontal line on the screen at a height of 67 to 70 cm from the ground;
3. Switch on the headlight at low beam and check that the horizontal borderline of the projected light beam between the dark and light area is not higher than the horizontal line drawn on the screen;
4. If this is not the case, regulate the headlight by turning screw "A".

### Front direction indicators

To replace a burnt out bulb remove the right and left screw «F».

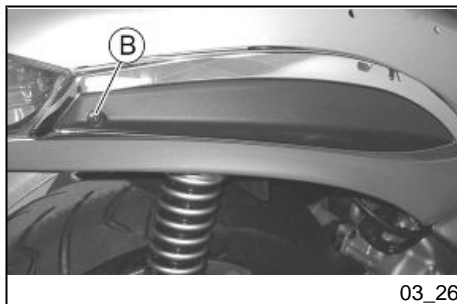

03\_26

### Rear optical unit (03\_26, 03\_27, 03\_28)

To remove the rear light assembly, proceed as follows:

1. Remove the two side mouldings.
2. Remove the plastic cover from the lower side of the luggage rack by removing the two screws of the housing "D".
3. Remove screw "C"
4. Remove screws "B" and pull out the rear light assembly.
5. If necessary, replace the blown bulb.

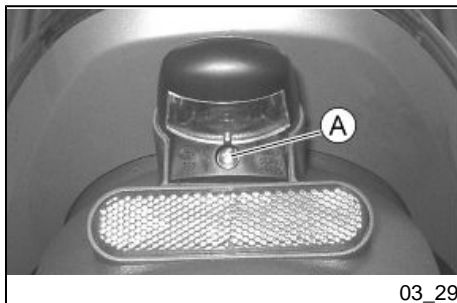
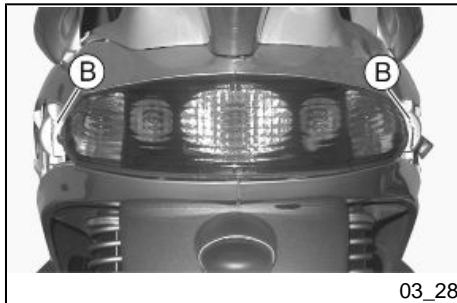
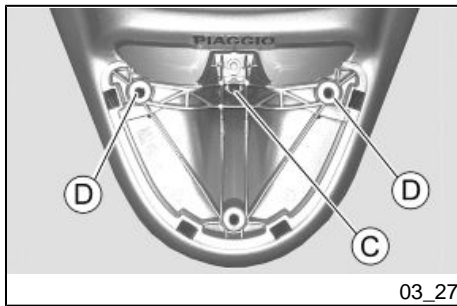

#### N.B.

IF MISTING IS NOTICED ON THE INSIDE OF THE HEADLAMP GLASS, THIS DOES NOT INDICATE A FAULT AND IS RELATED TO THE HUMIDITY AND/OR TO LOW TEMPERATURES.

THE PHENOMENON SHOULD QUICKLY DISAPPEAR WHEN THE LIGHT IS SWITCHED ON.

THE PRESENCE OF DROPS OF WATER, ON THE OTHER HAND, COULD INDICATE THAT WATER IS INFILTRATING. CONTACT THE PIAGGIO AFTER-SALES SERVICE NETWORK.

#### Number plate light (03\_29)

Remove the support by removing screw "A"



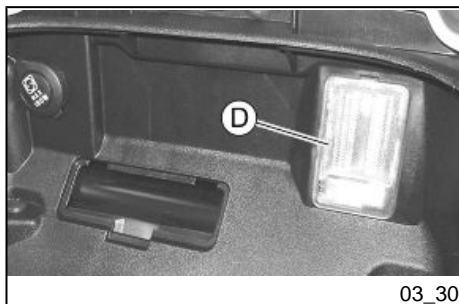

03\_30

### Helmet compartment lighting bulb (03\_30)

Open the helmet compartment, take out the pressure mounted transparent cover "D" and replace the bulb.

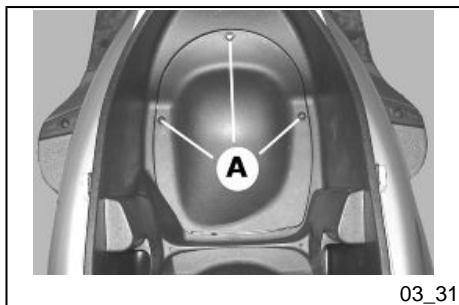

03\_31

### Idle adjustment (03\_31, 03\_32)

Proceed as follows:

1. Rest the vehicle onto its centre-stand and lift the seat (as described in the section «Accessing the helmet compartment - opening the seat»).
2. Loosen the fixing screws, «A», and remove the carburettor flap.
3. Start the engine, hence tighten or loosen the idle adjusting screw, «B», until the idle speed is within the prescribed limits, and the rear wheel is not spinning, i.e. the clutch is not engaged.

Should the adjustment be found difficult to perform, please contact your local **PIAGGIO Dealer or Authorised Service Station** so that a complete **CO** adjustment may be carried out.

#### WARNING



**IDLE SPEED MUST BE ADJUSTED WHEN THE ENGINE IS VERY HOT. BEFORE THIS OPERATION, MAKE SURE THAT THE THROTTLE GRIP HAS THE RECOMMENDED BACKLASH. IF BACKLASH IN THE THROTTLE CONTROL TRANS-**

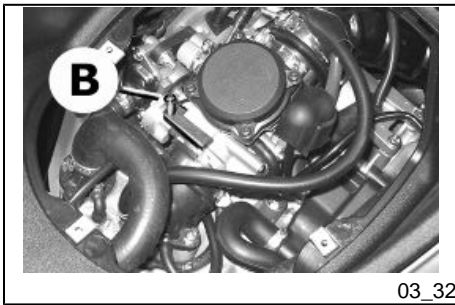

03\_32

**MISSION NEEDS ADJUSTING TAKE YOUR SCOOTER TO A PIAGGIO DEALER OR AUTHORISED SERVICE CENTRE**

### Characteristic

#### **Idling**

around 1650±50 revs/min.

### **Front and rear disc brake**

The brake disc and pad wear is automatically compensated, therefore it has no effect on the functioning of the front and rear brakes. For this reason it is not necessary to adjust the brakes. An excessively elastic brake lever stroke may indicate the presence of air in the braking circuit or a failure in the braking system. In this case, mainly due to the importance of brakes to guarantee safe riding conditions, the vehicle should be taken to an **Authorised Service Centre or Dealer**.

#### **CAUTION**



**THE BRAKING ACTION SHOULD BEGIN AFTER ABOUT 1/3 OF THE BRAKE LEVER STROKE.**

#### **CAUTION**



**HAVE THE BRAKE PADS CHECKED BY THE DEALER ACCORDING TO THE CHECKS SPECIFIED IN THE SCHEDULED MAINTENANCE TABLE. HOWEVER, IN THE EVENT OF NOISES COMING FROM THE FRONT AND/OR REAR BRAKE SYSTEM DURING OPERATION, IT IS ADVISABLE TO HAVE THE BRAKE SYS-**

TEM CHECKED BY A PIAGGIO DEALER OR AUTHORISED SERVICE CENTRE. AFTER REPLACING THE BRAKE PADS, DO NOT USE THE SCOOTER BEFORE HAVING USED THE BRAKE LEVER SEVERAL TIMES IN ORDER TO ALLOW THE PISTONS TO SETTLE AND THE LEVER STROKE TO BE SET TO THE CORRECT POSITION.

**CAUTION**



THE PRESENCE OF SAND, MUD, SNOW MIXED WITH SALT, ETC. ON THE ROAD, CAN DRASTICALLY REDUCE THE DURATION OF THE BRAKE PADS. IN ORDER TO AVOID THIS, WE RECOMMEND WASHING THE VEHICLE FREQUENTLY WHEN RIDING IN THESE ROAD CONDITIONS.

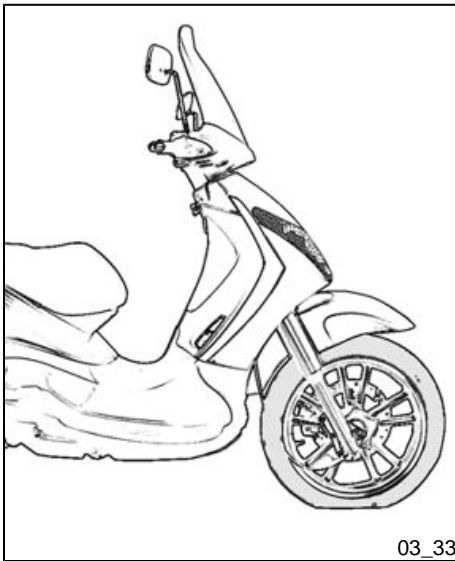

### Puncture (03\_33)

The vehicle is equipped with Tubeless tyres (without inner tube). In the event of a puncture, contrary to the situation with a tyre with inner tube, the tyre deflates more slowly, resulting in a greater steering safety. In the event of a puncture, it is admissible to make an emergency repair using an "inflate and repair" spray can. For a final repair, take your vehicle to an **Authorised Service Centre or Dealer**. The replacement of a tyre involves removing the wheel in question. Take your vehicle to an **Authorised Service Centre or Dealer** for these operations.

#### CAUTION



**TO USE THE "INFLATE AND REPAIR" SPRAY PROPERLY FOLLOW THE INSTRUCTIONS ON THE PACKAGING.**

#### WARNING



**THE WHEELS FITTED WITH TYRES SHOULD ALWAYS BE BALANCED. RIDING THE VEHICLE WITH VERY LOW TYRE PRESSURE OR WITH INCORRECTLY BALANCED TYRES CAN LEAD TO DANGEROUS STEERING VIBRATIONS.**

## Periods of inactivity (03\_34)

We recommend carrying out the following operations:

1. Clean the scooter thoroughly and then cover it with a canvas;
2. With engine off and piston at the bottom dead centre, remove the spark plug, fill with 1÷2 cm<sup>3</sup> of oil (adding more than this quantity is dangerous for the engine). Operate the starter button 1-2 times for roughly 1 second to turn the engine over slowly, then insert the spark plug again;
3. Drain all the fuel from the scooter; spread antirust grease on the unpainted metal parts; keep the wheels lifted above the ground by resting the chassis on two wooden wedges;
4. As regards the battery, follow the instructions in the «Battery» section.

## Recommended products

### AGIP CITY HI TEC 4T

*Oil to lubricate flexible transmissions (throttle control)*

Oil for 4-stroke engines

## Cleaning the vehicle

Use a low pressure jet of water to soften the caked dirt and mud deposited on the painted surfaces. Once softened, sponge off mud and dirt using a car body sponge soaked in a car body shampoo and water solution (2-4% of car shampoo in water). Then rinse abundantly with water, and dry with a shammy cloth. For the outside of the engine, use petroleum, a brush and clean cloths. Petrol can damage paintwork. Remember that any polishing with silicone wax must always be preceded by washing.



03\_34

**CAUTION**

**DETERGENTS CAN POLLUTE WATER. THE VEHICLE MUST BE WASHED AT A WASH STATION EQUIPPED WITH A SPECIAL WATER PURIFICATION SYSTEM.**

**WARNING**

**THE USE OF A HIGH-PRESSURE WATER JET IS STRONGLY DISCOURAGED FOR ANY ENGINE CLEANING OPERATION; HOWEVER, IF NO OTHER MEANS ARE AVAILABLE, IT IS THEN NECESSARY TO:**

- **ONLY USE THE FAN JET.**
- **DO NOT PLACE THE NOZZLE CLOSER THAN 60 CM.**
- **DO NOT USE WATER AT TEMPERATURES OVER 40°C.**
- **DO NOT USE HIGH-PRESSURE WATER JETS.**
- **DO NOT STEAM WASH.**
- **DO NOT DIRECT THE JET AT: THE CARBURETTOR, THE ELECTRIC CABLES, THE SLOT DIFFUSERS IN THE TRANSMISSION COVER AND THE SCROLL COVER.**

**CAUTION**

**NEVER WASH THE SCOOTER IN DIRECT SUNLIGHT, ESPECIALLY IN SUMMER WHEN THE BODYWORK IS STILL HOT AS THE SHAMPOO COULD DAMAGE THE PAINTWORK IF IT DRIES BEFORE BEING RINSED OFF. NEVER USE CLOTHS SOAKED IN ALCOHOL, PETROL, DIESEL OIL OR KEROSENE FOR CLEANING THE PAINTED OR PLASTIC SURFACES, IN ORDER NOT TO DAMAGE THE LUSTRE FINISH OR ALTER THE MECHANICAL PROPERTIES. USING SILICONE-BASED WAX CAN DAMAGE THE PAINTED SURFACES, DEPENDING**

ON THE VEHICLE COLOUR (SATIN COLOURS). FOR FURTHER INFORMATION ON THIS MATTER, CONTACT AN AUTHORISED SERVICE CENTRE .

### DIFFICULT STARTING

No fuel in tank	Refuelling
Filters, carburettor jets dirty or clogged, fuel filter, fuel pipes clogged, fuel pump damaged	Contact an <b>Authorised Piaggio Service Centre</b>
Battery flat	Recharge the battery.

### IGNITION PROBLEM

No spark from spark plug. Due to the presence of high voltage, this element should only be checked by an expert.	Contact an <b>Authorised Piaggio Service Centre</b>
--	---

### LACK OF COMPRESSION

Spark plug loose. Loose cylinder head, worn piston retaining rings. Incorrect valve clearance	Screw the spark plug. Contact an <b>Authorised Piaggio Service Centre</b>
---	--

## **HIGH CONSUMPTION AND LOW PERFORMANCE**

Air filter blocked or dirty.	Clean with water and shampoo and impregnate with petrol and specific oil (section «Removing the air filter»)
------------------------------	--

## **INSUFFICIENT BRAKING**

Greasy disc. Worn pads	Contact an <b>Authorised Piaggio Service Centre</b>
Air in the front and rear brake circuits	Contact an <b>Authorised Piaggio Service Centre</b>

## **INEFFICIENT SUSPENSIONS**

Inefficient shock absorbers, oil leakage, deteriorated end of stroke buffers.	Contact an <b>Authorised Service Centre</b>
---	---

## **IRREGULAR AUTOMATIC TRANSMISSION**

Deteriorated variable speed rollers and/or driving belt and/or clutch	Contact an <b>Authorised Service Centre</b>
---	---



## **EXHAUST NOISE**

Depression tube damaged/  
disconnected or secondary valve  
damaged

Contact an **Authorised Service  
Centre**



# Beverly 125 - 250



**Chap. 04**  
**Technical data**

### **DATA 125**

Version	125
Engine	single-cylinder, four-stroke
Bore x stroke	57 x 48.6 mm
Cubic capacity	124 cm <sup>3</sup>
Compression ratio	12 :1
ignition advance (before TDC)	10° at 2000 rpm - 34° at 6000 rpm
Walbro carburettor	WVF 7G* Ø 29
Carburettor Keihin	CVEK-30
Spark plug	NGK CR 8EB
Maximum speed	105 km/h
valve clearance	intake: 0.10 mm - discharge: 0.15 mm

**\* The identification letter can vary every time the carburettor is updated.**

### **DATA 250**

Version	250
Engine	Single-cylinder, four-stroke
Bore x stroke	72 x 60 mm

Cubic capacity	244.29 cm <sup>3</sup>
Compression ratio	10.5 - 11.5 : 1
ignition advance (before TDC)	10° ± 1° at 2000 rpm - 32° ± 1° at 6500 rpm
Walbro carburettor	WVF 7G* Ø 29
Carburettor Keihin	CVEK-30
Spark plug	CHAMPION RG4HC
Max speed	124 Km/h
Valve clearance	intake: 0.10 mm discharge: 0.15 mm

**\* The identification letter can vary every time the carburettor is updated.**

### **TECHNICAL DATA BEVERLY 125-250**

Maximum width	760 mm
Maximum length	2110 mm
Overall height	1480 mm
Wheel base	1470 mm
Saddle height	785 mm
Fuel supply	with unleaded petrol; carburettor and vacuum pump.
Exhaust muffler	absorption-type exhaust muffler with catalytic converter.

Electronic ignition	capacitative, with variable timing and separate HV coil
Cooling	Forced liquid circulation cooling.
Lubrication	Engine lubrication with lobe pump (inside crankcase) controlled by a chain with double filter: mesh and paper.
Transmission	With automatic expandable pulley variator with torque server, V belt, self-ventilating automatic centrifugal dry clutch, gear reduction unit and transmission housing with forced air circulation cooling.
Front brake	disc brake, diameter 260 mm (right-hand side of scooter), with hydraulic servo operated from the handlebar with the right-hand lever.
Rear brake	disc brake, diameter 260 mm, with hydraulic control operated from the handlebar.
Front wheel:	alloy rim:16" x 3.50
Rear wheel	alloy rim: 16" x 3.50
Front tyre	Without inner tube: 110/70-16"
Rear tyre	Without inner tube: 140/70-16"
Front suspension	Hydraulic telescopic fork with Ø 35 mm stem
Rear suspension	Single arm with two double-acting hydraulic shock absorbers and

	preloading adjustable to 4 positions.
Chassis	Tubular and sheet steel.
Dry weight	160 kg
Maximum load	180 kg.
Fuel tank capacity	9,8 litres (indicative value).
Reserve	Fuel reserve: 2 litres
Engine oil (empty)	Capacity: 1,1 l.
Engine oil (oil and oil filters change)	Capacity: 1.0 l
Rear hub oil	250 cc. (125 cc and 250 cc.)

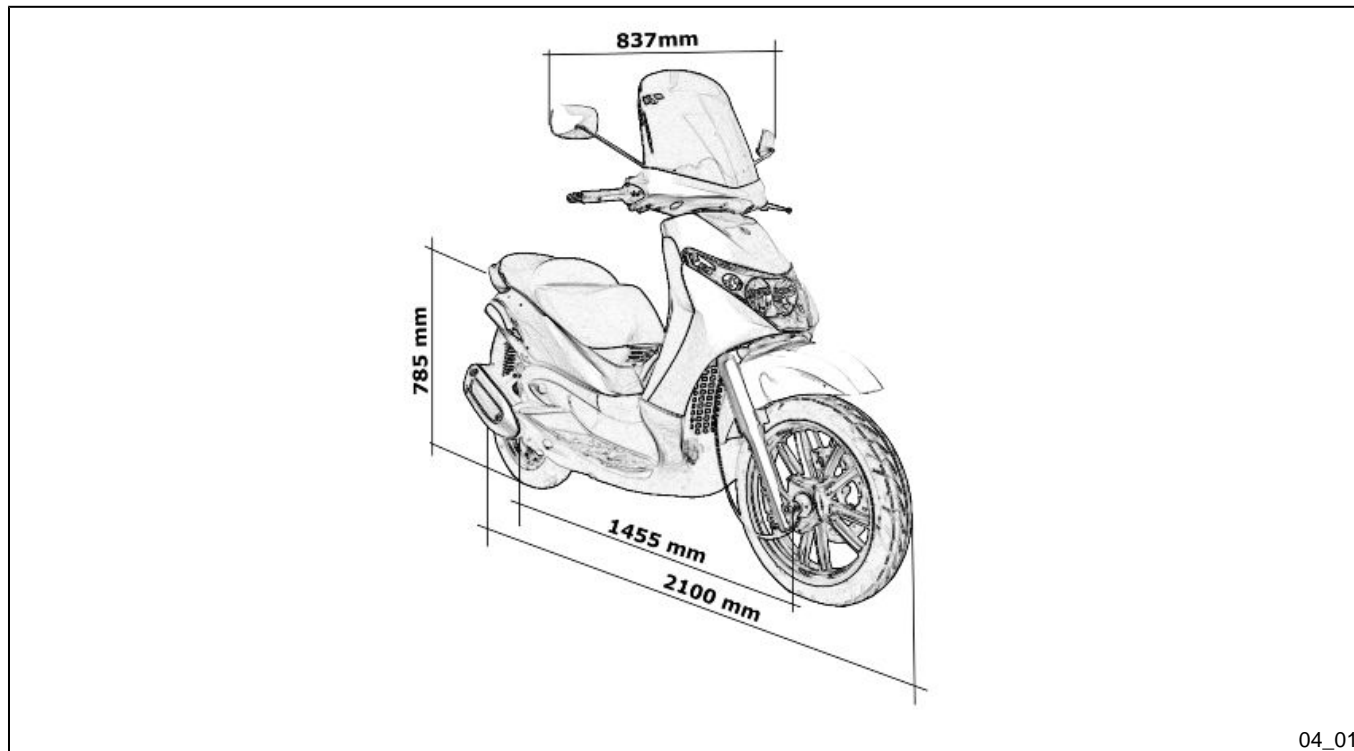

04\_01

### Kit equipment

One box spanner; one lever for box spanner; one twin screwdriver; one hexagonal wrench (mm 6); one special wrench for adjusting the rear shock absorbers. The tools are stored in the helmet compartment.







# Beverly 125 - 250



**PIAGGIO®**



**Chap. 05  
Spare parts and  
accessories**



05\_01

## Warnings (05\_01)

### WARNING



TO PREVENT ACCIDENTS AND TO GUARANTEE PROPER STABILITY, PERFORMANCE AND SAFETY, RIDE THE VEHICLE VERY CAREFULLY WHEN IT IS FITTED WITH ACCESSORIES OR WITH UNUSUAL LOADS.

### WARNING



IT IS ALSO RECOMMENDED THAT "ORIGINAL PIAGGIO SPARE PARTS" BE USED, AS THESE ARE THE ONLY ONES OFFERING YOU THE SAME QUALITY GUARANTEE AS THOSE INITIALLY FITTED ON THE SCOOTER. THE USE OF NON-ORIGINAL SPARE PARTS RENDERS THE WARRANTY VOID.

### WARNING



PIAGGIO MARKETS ITS OWN LINE OF ACCESSORIES THAT ARE RECOGNISED AND GUARANTEED FOR USE. IT IS THEREFORE ESSENTIAL, IN ORDER TO CHOOSE AND MOUNT THE ACCESSORIES CORRECTLY, TO CONTACT AN AUTHORISED DEALER OR SERVICE CENTRE. THE USE OF NON-ORIGINAL ACCESSORIES MAY AFFECT THE STABILITY AND OPERATION OF YOUR VEHICLE AND REDUCE SAFETY LEVELS WITH POTENTIAL RISKS FOR THE RIDER.

**WARNING**

**NEVER RIDE THE SCOOTER EQUIPPED WITH ACCESSORIES (TOP BOX AND/OR WINDSHIELD) AT A SPEED HIGHER THAN 100 km/h.**

**THE SCOOTER CAN BE RIDDEN AT A HIGHER SPEED WITHOUT THE ACCESSORIES MENTIONED BEFORE WITHIN THE LIMITS ESTABLISHED BY LAW.**

**IF THERE SHOULD BE NON-PIAGGIO ACCESSORIES INSTALLED, OR AN ABNORMAL LOAD, OR IF THE SCOOTER IS NOT IN A GENERALLY GOOD CONDITION, OR WHENEVER WEATHER CONDITIONS DEMAND IT, SPEED SHOULD BE REDUCED FURTHER.**

**WARNING**

**BE EXTREMELY CAREFUL WHEN INSTALLING AND REMOVING THE MECHANICAL ANTI-THEFT DEVICE ON THE VEHICLE ( U-SHAPED PADLOCK, DISK BLOCK, ETC.).**

**MAINLY NEAR THE BRAKE PIPES, TRANSMISSIONS AND/OR ELECTRIC CABLES, AN INCORRECT INSTALLATION OR REMOVAL OF THE ANTI-THEFT DEVICE AS WELL AS LEAVING IT ON BEFORE STARTING THE VEHICLE CAN SERIOUSLY DAMAGE ITS COMPONENTS, COMPROMISE THE CORRECT FUNCTIONING OF THE VEHICLE AND USERS' SAFETY.**



# Beverly 125 - 250



**Chap. 06  
Programmed  
maintenance**

## Scheduled maintenance table

Adequate maintenance is fundamental to ensuring long-lasting, optimum operation and performance of your vehicle.

To this end, a series of checks and maintenance operations (at the owner's expense) have been suggested, which are included in the summary table on the following page. Any minor faults should be reported without delay to an **Authorised Service Centre or Dealer** without waiting until the next scheduled service to solve it.

All scheduled maintenance services must be carried out at the specified intervals, even if the stated mileage has not yet been reached. Punctual scooter servicing is essential to ensure your warranty remains valid. For any further information concerning Warranty procedures and "Scheduled Maintenance", please refer to the "Warranty Booklet".

### EVERY 2 YEARS

Coolant - change
------------------

Brake fluid - change
----------------------

Secondary air filter (external/internal) - cleaning (125)
---

### EVERY 3.000 KM (125)

Engine oil - level check/ top-up
----------------------------------



**AT 1.000 KM (125)**

Engine oil - replacement
--------------------------

Hub oil - change
------------------

Engine oil - change
---------------------

Idle speed (*) - adjustment
-----------------------------

Throttle lever - adjustment
-----------------------------

Steering - adjustment
-----------------------

Brake control levers - greasing
---------------------------------

Brake pads - check condition and wear
---------------------------------------

Brake fluid level - check
---------------------------

Safety locks - check
----------------------

Electrical system and battery - check
---------------------------------------

Tyre pressure and wear - check
--------------------------------

Vehicle and brake test - road test
------------------------------------

(\*) See norms under the «Idle Adjustment» section.

**AT 6.000 KM (125)**

engine oil- change(125)
-------------------------

Hub oil level - check
-----------------------

Spark plug/ electrode gap - check
-----------------------------------

---

Air filter - clean

oil filter - change(125)

valve clearance 125 - check

Sliding blocks / variable speed rollers - check

Driving belt - checking

Coolant level - check

Brake pads - check condition and wear

Brake fluid level - check

Electrical system and battery - check

Tyre pressure and wear - check

Vehicle and brake test - road test

---

### **AT 12.000 KM AND AT 60.000 KM (125)**

---

Engine oil - replacement

Hub oil level - check

Spark plug / electrode gap - check / replacement

Air filter - clean

Engine oil - change

Idle speed (\*) - adjustment

Sliding block / variable speed rollers - change

Throttle lever - adjustment

---

Coolant level - check
-----------------------

Steering - adjustment
-----------------------

Brake control levers - greasing
---------------------------------

Brake pads - check condition and wear
---------------------------------------

Brake fluid level - check
---------------------------

Transmission elements - lubrication
-------------------------------------

Safety locks - check
----------------------

Suspensions - check
---------------------

Electrical system and battery - check
---------------------------------------

Headlight - adjustment
------------------------

Tyre pressure and wear - check
--------------------------------

Vehicle and brake test - road test
------------------------------------

Transmission Belt (125 cc) - Replacement
--

*(\*) See norms under the «Idle Adjustment» section.*

### **AT 18.000 KM AND AT 54.000 KM (125)**

engine oil- change(125)
-------------------------

Hub oil level - check
-----------------------

Spark plug/ electrode gap - check
-----------------------------------

Air filter - clean
--------------------

oil filter - change(125)
--------------------------

valve clearance 125 - check

Sliding blocks / variable speed rollers - check

Driving belt - checking

Coolant level - check

Radiator - external cleaning/ check

Brake pads - check condition and wear

Brake fluid level - check

Electrical system and battery - check

Tyre pressure and wear - check

Vehicle and brake test - road test

### **AT 24.000 KM AND AT 48.000 KM (125)**

Engine oil - replacement

Hub oil - change

Spark plug / electrode gap - check / replacement

Air filter - clean

Engine oil - change

Idle speed (\*) - adjustment

Sliding block / variable speed rollers - change

Throttle lever - adjustment

Coolant level - check

---

Steering - adjustment

---

Brake control levers - greasing

---

Brake pads - check condition and wear

---

Brake fluid level - check

---

Transmission elements - lubrication

---

Safety locks - check

---

Suspensions - check

---

Electrical system and battery - check

---

Headlight - adjustment

---

Tyre pressure and wear - check

---

Vehicle and brake test - road test

---

Transmission Belt (125 cc) - Replacement

(\*) See norms under the «Idle Adjustment» section.

### **AT 30.000 KM, AT 42.000 KM AND AT 66.000 KM (125)**

---

Hub oil level - check

---

Spark plug/ electrode gap - check

---

Air filter - clean

---

Variable speed rollers - check or replacement

---

Driving belt - checking

---

Coolant level - check

---

Brake pads - check condition and wear

Brake fluid level - check

Electrical system and battery - check

Tyre pressure and wear - check

Vehicle and brake test - road test

engine oil- change(125)

oil filter - change(125)

### **AT 36.000 KM (125)**

Engine oil - replacement

Hub oil level - check

Spark plug / electrode gap - check / replacement

Air filter - clean

Engine oil - change

valve clearance 125 - check

Idle speed (\*) - adjustment

Sliding block / variable speed rollers - change

Throttle lever - adjustment

Driving belt - replacement

Coolant level - check

Radiator - external cleaning/ check

Steering - adjustment

Brake control levers - greasing

Brake pads - check condition and wear

Brake fluid hoses - replacement

Brake fluid level - check

Transmission elements - lubrication

Safety locks - check

Suspensions - check

Electrical system and battery - check

Headlight - adjustment

Tyre pressure and wear - check

Vehicle and brake test - road test

(\*) See norms under the «Idle Adjustment» section.

### **AT 72.000 KM (125)**

Engine oil - replacement

Hub oil - change

Spark plug / electrode gap - check / replacement

Air filter - clean

Engine oil - change

valve clearance 125 - check

Idle speed (\*) - adjustment

Sliding block / variable speed rollers - change

Throttle lever - adjustment

Driving belt - replacement

Coolant level - check

Radiator - external cleaning/ check

Steering - adjustment

Brake control levers - greasing

Brake pads - check condition and wear

Brake fluid hoses - replacement

Brake fluid level - check

Transmission elements - lubrication

Safety locks - check

Suspensions - check

Electrical system and battery - check

Headlight - adjustment

Tyre pressure and wear - check

Vehicle and brake test - road test

(\*) See norms under the «Idle Adjustment» section.



**EVERY 5.000 KM (250)**

Engine oil - level check/ top-up

Brake pads - check condition and wear

**AT 1.000 KM (250)**

Safety locks - check

Throttle lever - adjustment

Engine oil - change

Electrical system and battery - check

Coolant level - check

Brake fluid level - check

Engine oil - replacement

Brake pads - check condition and wear

Tyre pressure and wear - check

Vehicle and brake test - road test

Hub oil - change

Idle speed (\*) - adjustment

Steering - Check

**AT 10.000 KM AT 30.000 KM AT 50.000 KM AND AT  
70.000 KM (250)**

Safety locks - check

Spark plug - replacement

Driving belt - checking

Throttle lever - adjustment

Air filter - clean

Air filter belt compartment - check

Engine oil - change

Electrical system and battery - check

Coolant level - check

Brake fluid level - check

Engine oil - replacement

Brake pads - check condition and wear

Sliding block / variable speed rollers - change

Tyre pressure and wear - check

Vehicle and brake test - road test

Hub oil - check

Idle speed (\*) - adjustment

Suspensions - check

Steering - Check

(\*) See norms under the «Idle Adjustment» section.

**AT 20.000 KM 40.000 KM 60.000 KM AND AT 80.000 KM  
(250)**

Spark plug - replacement

Driving belt - replacement

Throttle lever - adjustment

Air filter - clean

Secondary air filter - cleaning

Air filter belt compartment - check

Engine oil - change

Valve clearance - check

Electrical system and battery - check

Coolant level - check

Brake fluid level - check

Engine oil - replacement

Brake pads - check condition and wear

Sliding block / variable speed rollers - change

Tyre pressure and wear - check

Vehicle and brake test - road test

Hub oil - change

Idle speed (\*) - adjustment

Suspensions - check

Steering - Check

(\*) See norms under the «Idle Adjustment» section.

## RECOMMENDED PRODUCTS TABLE

Product	Description	Specifications
AGIP ROTRA 80W-90	Rear hub oil	SAE 80W/90 Oil that exceeds the requirements of API GL3 specifications
AGIP CITY HI TEC 4T	Oil to lubricate flexible transmissions (throttle control)	Oil for 4-stroke engines
AGIP FILTER OIL	Oil for air filter sponge	Mineral oil with specific additives for increased adhesiveness
AGIP GP 330	Grease for brake levers, throttle	White calcium complex soap-based spray grease with NLGI 2; ISO-L-XBCIB2
AGIP CITY HI TEC 4T	Engine oil	SAE 5W-40, API SL, ACEA A3, JASO MA Synthetic oil
AGIP BRAKE 4	Brake fluid	FMVSS DOT 4 Synthetic fluid
AGIP PERMANENT SPEZIAL	coolant	Monoethylene glycol-based antifreeze fluid, CUNA NC 956-16

# TABLE OF CONTENTS

## **A**

Air filter: 41

## **B**

Battery: 46, 47

Brake: 44, 58

## **D**

Disc brake: 58

## **E**

Engine oil: 34, 35

Engine stop: 12

## **F**

Fuel: 16

Fuses: 49

## **H**

Headlight: 55

Horn: 11

Hub oil: 37

## **I**

Identification: 19

Immobilizer: 12, 15

Instrument panel: 9

## **K**

Key switch: 9

Keys: 13

## **L**

Light switch: 11

## **M**

Maintenance: 33, 79, 80

## **S**

Saddle: 17, 19

Scheduled maintenance: 80

Shock absorbers: 23

Spark plug: 39

Stand: 28

Start-up: 12

## **T**

Tank: 16

Technical Data: 67

Transmission: 29

Tyres: 38



The descriptions and illustrations given in this publication are not binding. While the basic specifications as described and illustrated in this manual remain unchanged, PIAGGIO-GILERA reserves the right, at any time and without being required to update this publication beforehand, to make any changes to components, parts or accessories, which it considers necessary to improve the product or which are required for manufacturing or construction reasons.

Not all versions/models shown in this publication are available in all countries. The availability of single versions should be checked at the official Piaggio sales network.

"© Copyright 2007 - PIAGGIO & C. S.p.A. Pontedera. All rights reserved. Reproduction of this publication in whole or in part is prohibited."

PIAGGIO & C. S.p.A. - After-Sales

V.le Rinaldo Piaggio, 23 - 56025 PONTEDERA (Pi)