



SERVICE STATION MANUAL

854146



SL 750 SHIVER



SERVICE STATION MANUAL

SL 750 SHIVER

THE VALUE OF SERVICE

Thanks to continuous technical updates and specific training programs on aprilia products, only **aprilia Official Network** mechanics know this vehicle fully and have the special tools necessary to carry out maintenance and repair operations correctly.

The reliability of the vehicle also depends on its mechanical conditions. Checking the vehicle before riding, its regular maintenance and the use of **Original aprilia Spare Parts** only are essential factors! For information about the nearest **Official Dealer and/or Service Centre**, consult the Yellow Pages or search directly on the inset map in our Official Website:

www.aprilia.com

Only aprilia Original Spare Parts ensure products already studied and tested during the vehicle design stage. All aprilia Original Spare Parts undergo quality control procedures to guarantee full reliability and duration.

The descriptions and illustrations given in this publication are not binding; While the basic characteristics as described and illustrated in this manual remain unchanged, aprilia reserves the right, at any time and without being required to update this publication beforehand, to make any changes to components, parts or accessories, which it considers necessary to improve the product or which are required for manufacturing or construction reasons.

Not all versions shown in this publication are available in all countries. The availability of individual versions should be confirmed with the official aprilia sales network.

© Copyright 2007- aprilia. All rights reserved. Reproduction of this publication in whole or in part is prohibited. aprilia - After sales service.

aprilia trademark is property of Piaggio & C. S.p.A.

SERVICE STATION MANUAL

SL 750 SHIVER

NOTE Provides key information to make the procedure easier to understand and carry out.

CAUTION Refers to specific procedures to carry out for preventing damages to the vehicle.

WARNING Refers to specific procedures to carry out to prevent injuries to the repairer.



Personal safety Failure to completely observe these instructions will result in serious risk of personal injury.



Safeguarding the environment Sections marked with this symbol indicate the correct use of the vehicle to prevent damaging the environment.



Vehicle intactness The incomplete or non-observance of these regulations leads to the risk of serious damage to the vehicle and sometimes even the invalidity of the guarantee.



INDEX OF TOPICS

CHARACTERISTICS

CHAR

SPECIAL TOOLS

S-TOOLS

MAINTENANCE

MAIN

TROUBLESHOOTING

TROUBL

ELECTRICAL SYSTEM

ELE SYS

ENGINE FROM VEHICLE

ENG VE

ENGINE

ENG

POWER SUPPLY

P SUPP

SUSPENSIONS

SUSP

CHASSIS

CHAS

BRAKING SYSTEM

BRAK SYS

CLUTCH SYSTEM

CLU SYS

COOLING SYSTEM

COOL SYS

BODYWORK

BODYW

INDEX OF TOPICS

CHARACTERISTICS

CHAR

Rules

Safety rules

Carbon monoxide

If you need to keep the engine running in order to carry out any procedure, please ensure that you do so in an open or very well ventilated area. Never let the engine run in an enclosed area. If you do work in an enclosed area, make sure to use a smoke-extraction system.

CAUTION



EXHAUST EMISSIONS CONTAIN CARBON MONOXIDE, A POISONOUS GAS WHICH CAN CAUSE LOSS OF CONSCIOUSNESS AND EVEN DEATH.

Fuel

CAUTION



FUEL USED TO POWER INTERNAL COMBUSTION ENGINES IS HIGHLY FLAMMABLE AND CAN BECOME EXPLOSIVE UNDER SPECIFIC CONDITIONS. IT IS THEREFORE RECOMMENDED TO CARRY OUT REFUELLING AND MAINTENANCE PROCEDURES IN A VENTILATED AREA WITH THE ENGINE SWITCHED OFF. DO NOT SMOKE DURING REFUELLING AND NEAR FUEL VAPOURS, AVOIDING ANY CONTACT WITH NAKED FLAMES, SPARKS OR OTHER SOURCES WHICH MAY CAUSE THEM TO IGNITE OR EXPLODE.

DO NOT DISPERSE FUEL IN THE ENVIRONMENT.

KEEP OUT OF THE REACH OF CHILDREN

Hot components

The engine and the exhaust system components get very hot and remain in this condition for a certain time interval after the engine has been shut off. Before handling these components, make sure that you are wearing insulating gloves or wait until the engine and the exhaust system have cooled down.

Coolant

The coolant contains ethylene glycol which, under certain conditions, can become flammable.

When it burns, ethylene glycol produces an invisible flame which however can cause burns.

CAUTION



PAY ATTENTION NOT TO POUR COOLANT ON HOT ENGINE OR EXHAUST SYSTEM COMPONENTS; IT MAY CATCH FIRE PRODUCING INVISIBLE FLAMES. IT IS ADVISABLE TO WEAR LATEX GLOVES WHEN SERVICING THE VEHICLE. EVEN IF IT IS TOXIC, THE COOLANT HAS A SWEET FLAVOUR WHICH MAKES IT VERY ATTRACTIVE TO ANIMALS. NEVER LEAVE THE COOLANT IN OPEN CONTAINERS IN AREAS ACCESSIBLE TO ANIMALS AS THEY MAY DRINK IT.

KEEP OUT OF THE REACH OF CHILDREN

DO NOT REMOVE THE RADIATOR CAP WHEN THE ENGINE IS STILL HOT. THE COOLANT IS UNDER PRESSURE AND MAY CAUSE BURNS.

Used engine oil and transmission oil

CAUTION



IT IS ADVISABLE TO WEAR LATEX GLOVES WHEN SERVICING THE VEHICLE.

ENGINE OR TRANSMISSION OIL MAY CAUSE SERIOUS INJURIES TO THE SKIN IF HANDLED FOR PROLONGED PERIODS OF TIME AND ON A REGULAR BASIS.

WASH YOUR HANDS CAREFULLY AFTER HANDLING OIL.

HAND THE OIL OVER TO OR HAVE IT COLLECTED BY THE NEAREST USED OIL RECYCLING COMPANY OR THE SUPPLIER.

DO NOT DISPOSE OF OIL IN THE ENVIRONMENT

KEEP OUT OF THE REACH OF CHILDREN

Brake and clutch fluid



THE BRAKE AND CLUTCH FLUIDS CAN DAMAGE THE PLASTIC OR RUBBER PAINTED SURFACES. WHEN SERVICING THE BRAKING SYSTEM OR THE CLUTCH SYSTEM PROTECT THESE COMPONENTS WITH A CLEAN CLOTH. ALWAYS WEAR PROTECTIVE GOGGLES WHEN SERVICING THE SYSTEMS. BRAKE AND CLUTCH FLUIDS ARE EXTREMELY HARMFUL FOR YOUR EYES. IN THE EVENT OF ACCIDENTAL CONTACT WITH THE EYES, RINSE THEM IMMEDIATELY WITH ABUNDANT COLD, CLEAN WATER AND SEEK MEDICAL ADVICE.

KEEP OUT OF THE REACH OF CHILDREN

Battery electrolyte and hydrogen gas

CAUTION



THE BATTERY ELECTROLYTE IS TOXIC, CORROSIVE AND AS IT CONTAINS SULPHURIC ACID, IT CAN CAUSE BURNS WHEN IN CONTACT WITH THE SKIN. WHEN HANDLING BATTERY ELECTROLYTE, WEAR TIGHT-FITTING GLOVES AND PROTECTIVE APPAREL. IF THE ELECTROLYTIC FLUID COMES INTO CONTACT WITH THE SKIN, RINSE WELL WITH ABUNDANT FRESH WATER. IT IS PARTICULARLY IMPORTANT TO PROTECT THE EYES BECAUSE EVEN TINY AMOUNTS OF BATTERY ACID MAY CAUSE BLINDNESS. IF THE FLUID GETS INTO CONTACT WITH YOUR EYES, WASH WITH ABUNDANT WATER FOR FIFTEEN MINUTES AND CONSULT AN EYE SPECIALIST IMMEDIATELY. IF THE FLUID IS ACCIDENTALLY SWALLOWED, DRINK LARGE QUANTITIES OF WATER OR MILK, FOLLOWED BY MILK OF MAGNESIA OR VEGETABLE OIL AND SEEK MEDICAL ADVICE IMMEDIATELY. THE BATTERY RELEASES EXPLOSIVE GASES; KEEP IT AWAY FROM FLAMES, SPARKS, CIGARETTES OR ANY OTHER HEAT SOURCES. ENSURE ADEQUATE VENTILATION WHEN SERVICING OR RECHARGING THE BATTERY.

KEEP OUT OF THE REACH OF CHILDREN

BATTERY LIQUID IS CORROSIVE. DO NOT POUR IT OR SPILL IT, PARTICULARLY ON PLASTIC COMPONENTS. ENSURE THAT THE ELECTROLYTIC ACID IS COMPATIBLE WITH THE BATTERY TO BE ACTIVATED.

Maintenance rules

GENERAL PRECAUTIONS AND INFORMATION

When repairing, dismantling and reassembling the vehicle follow the recommendations reported below carefully.

BEFORE DISASSEMBLING COMPONENTS

- Before dismantling components, remove dirt, mud, dust and foreign bodies from the vehicle. Use the special tools designed for this bike, as required.

COMPONENTS REMOVAL

- Do not loosen and/or tighten screws and nuts using pliers or other tools other than the especially designed wrench.
- Mark positions on all connection joints (pipes, cables, etc.) before separating them, and identify them with distinctive symbols.
- Each component needs to be clearly marked in order to be identified during assembly.
- Clean and wash the removed components carefully using a low-flammability detergent.
- Keep coupled parts together since they have "adjusted" to each other due to normal wear and tear.
- Some components must be used together or replaced altogether.
- Keep away from heat sources.

REASSEMBLING COMPONENTS

CAUTION

BEARINGS MUST BE ABLE TO ROTATE FREELY, WITHOUT JAMMING AND/OR NOISE, OTHERWISE THEY NEED REPLACING.

- Only use ORIGINAL APRILIA SPARE PARTS.
- Comply with lubricant and consumables usage guidelines.
- Lubricate parts (whenever possible) before reassembling them.
- When tightening nuts and screws, start from the ones with the largest section or from the internal ones, moving diagonally. Tighten nuts and screws in successive steps before applying the tightening torque.
- Always replace self-locking nuts, washers, sealing rings, circlips, O-rings, split pins and screws with new ones if their tread is damaged.
- When fitting bearings, make sure to lubricate them well.
- Check that each component is fitted correctly.
- After a repair or routine maintenance procedure, carry out pre-ride checks and test the vehicle on private grounds or in an area with low traffic density.
- Clean all junction surfaces, oil guard rims and washers before refitting them. Smear a light layer of lithium-based grease on the oil guard rims. Reassemble the oil guard and the bearings with the brand or lot number facing outward (visible side).

ELECTRIC CONNECTORS

Electric connectors must be disconnected as described below as non-compliance with the procedure so described causes irreparable damage to both the connector and the cable harness:

Press the relevant safety hooks, if any.

- Grip the two connectors and disconnect them by pulling them in opposite directions.
- If there are signs of dirt, rust, humidity, etc., clean the connector internal parts carefully using a pressurised air jet.
- Make sure that the cables are correctly linked to the connector internal terminal ends.
- Then insert the two connectors making sure that they couple correctly (if the relevant hooks are provided, you will hear them "click" into place).

CAUTION

TO DISCONNECT THE TWO CONNECTORS, DO NOT PULL THE CABLES.

NOTE

THE TWO CONNECTORS CONNECT ONLY FROM ONE SIDE: CONNECT THEM THE RIGHT WAY ROUND.

TIGHTENING TORQUE**CAUTION**

DO NOT FORGET THAT THE TIGHTENING TORQUE OF ALL FASTENING ELEMENTS ON WHEELS, BRAKES, WHEEL SPINDLES AND OTHER SUSPENSION COMPONENTS PLAY A KEY ROLE IN ENSURING THE VEHICLE'S SAFETY AND MUST COMPLY WITH SPECIFIED VALUES. CHECK THE TIGHTENING TORQUE OF FASTENING PARTS ON A REGULAR BASIS AND ALWAYS USE A TORQUE WRENCH TO REASSEMBLE THESE COMPONENTS. FAILURE TO COMPLY WITH THESE RECOMMENDATIONS MAY CAUSE ONE OF THESE COMPONENTS TO GET LOOSE AND EVEN DETACHED, THUS BLOCKING A WHEEL, OR OTHERWISE COMPROMISE VEHICLE HANDLING. THIS CAN LEAD TO FALLS, WITH THE RISK OF SERIOUS INJURY OR DEATH.

Running-in

Engine run-in is essential to ensure engine long life and correct operation. Twisty roads and gradients are ideal to run in engine, brakes and suspensions effectively. Vary your driving speed during run-in. In this way, you allow for the work of components to be "loaded" and then "unloaded", thus cooling engine parts.

CAUTION

ONLY AFTER THE SERVICE AT THE END OF THE RUN-IN PERIOD CAN THE BEST PERFORMANCE OF YOUR VEHICLE BE OBTAINED.

Follow the guidelines detailed below:

- Do not twist the throttle grip abruptly and completely when the engine is working at a low revs, either during or after run-in.
- During the first 100 km (62 miles) operate the brakes with caution, avoid rough and long braking. That is to permit the adequate adjustment of the pad friction material to the brake discs.



AFTER THE SPECIFIED MILEAGE, TAKE YOUR VEHICLE TO AN Official aprilia Dealer FOR THE CHECKS INDICATED IN THE "AFTER-RUN-IN" TABLE IN THE SCHEDULED MAINTENANCE SECTION, TO AVOID INJURING YOURSELF, OTHERS AND/OR DAMAGING THE VEHICLE.

Vehicle identification

Write down the chassis and engine number in the specific space of this booklet. The chassis number is handy when purchasing spare parts.

CAUTION



ALTERING IDENTIFICATION NUMBERS IS AN OFFENCE WHICH CAN RESULT IN SEVERE CRIMINAL AND ADMINISTRATIVE CHARGES. PARTICULARLY MODIFYING THE CHASSIS NUMBER WILL IMMEDIATELY INVALIDATE THE WARRANTY.

This number is composed by numbers and letters, as in the example shown below.

ZD4RA0000YSXXXXXX

KEY:

ZD4: WMI (World manufacturer identifier) code;

RA: model;

000: version variation;

0: digit free

Y year of manufacture

S: production plant (S= Scorzè);

XXXXXX: progressive number (6 digits);

ENGINE NUMBER

The engine number is printed on the base of the left side engine crankcase.

Engine No.

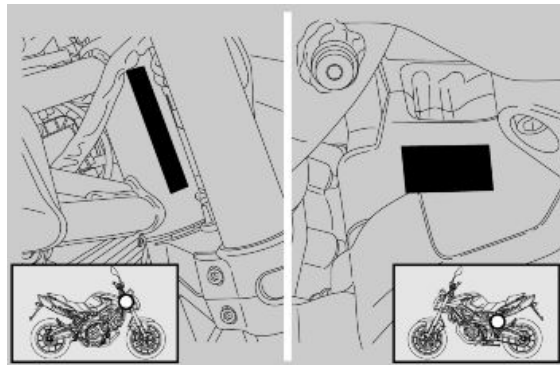

CHASSIS NUMBER

The chassis number is stamped on the right side of the headstock.

Chassis No.

Dimensions and mass

DIMENSIONS

Specification	Desc./Quantity
Max. length	2100 mm (82.68 in)
Max. width	800 mm (31.50 in)
Max. height (to top fairing)	1135 mm (44.69 in)
Saddle height	810 mm (31.89 in)

Specification	Desc./Quantity
Wheelbase	1440 mm (56.69 in)
Kerb weight (full fuel tank)	210 kg (463 lb)

Engine

<u>ENGINE</u>	
Specification	Desc./Quantity
Model	M551M
Type	90° longitudinal V-twin, 4-stroke, 4 valves per cylinder, 2 overhead camshafts.
Cylinder quantity	2
Overall engine capacity	749.9 cm ³ (45.76 cu.in)
Bore / stroke	92 x 56.4 mm (3.62 x 2.22 cu.in)
Valve clearance at intake	0.11 - 0.18 mm (0.0043 - 0.0071 in)
Outlet valve clearance	0.16 - 0.23 mm (0.0063 - 0.0091 in)
Compression ratio	11.0: 1
Start-up	electric
Engine revs at idle speed	1400 ± 100 rpm
Clutch	Multiple-disk, oil-bathed clutch with control on the left side of the handlebar
Lubrication system	Wet crankcase. Pressure system regulated by trochoidal pump
Air filter	with dry cartridge filter
Cooling	Fluid

<u>GEAR</u>	
Specification	Desc./Quantity
Type	Mechanical, 6 speeds with foot lever on the left-hand side of the engine

Transmission

<u>GEAR RATIOS</u>	
Specification	Desc./Quantity
Gear ratio	Gear primary drive 38/71
1st gear ratio	14/36 (secondary)
2nd gear ratio	17/32 (secondary)
3rd gear ratio	20/30 (secondary)
4th gear ratio	22/28 (secondary)
5th gear ratio	23/26 (secondary)
6th gear ratio	24/25 (secondary)
Final drive gear ratio	16/44

Capacities

<u>CAPACITY</u>	
Specification	Desc./Quantity
Fuel (reserve included)	15 l (3.30 UKgal; 3.96 USgal)
Fuel reserve	3 l (0.66 UKgal; 0.79 USgal)

Specification	Desc./Quantity
Engine oil	3.0 l (without oil filter change) (0.66 UKgal; 0.79 USgal) 3.2 l (without oil filter change) (0.70 UKgal; 0.85 USgal)
Fork oil quantity (for each stem):	535 cm ³ (32.65 cu.in)
Coolant	1.8 l (0.40 UKgal; 0.48 USgal)
Seats	2
Vehicle max. load	190 kg (418.9 lb) (Rider + passenger + luggage)

Drive chain

DRIVE CHAIN

Specification	Desc./Quantity
Type	Endless (without master link) and with sealed links. No. of links 108
Model	525 ZRPK

Electrical system

ELECTRICAL SYSTEM

Specification	Desc./Quantity
Battery	12V - 10 Ah
Main fuses	30A
Auxiliary fuses	3A, 10A, 15A, 20A
(Permanent magnet) Generator	13.5 V - 450 W at 6000 rpm

SPARK PLUGS

Specification	Desc./Quantity
Standard spark plugs	NGK CR7EKB
Spark plug electrode gap	0.6 ÷ 0.7 mm (0.024 ÷ 0.028 in)
Resistance	5 kOhm

BULBS

Specification	Desc./Quantity
Low-beam light	12 V - 55 W H7
High-beam light	12 V - 55 W H7
Front tail light	12V - 5W x 2
Turn indicator lights	12V - 10W
License plate light	12V - 5W
Rear tail light / stop light	12V - 5/21W x 2
Rpm indicator lighting	LED
Multifunction display lighting	LED

WARNING LIGHTS

Specification	Desc./Quantity
High-beam light	LED
Right turn indicator	LED
Left turn indicator	LED
General warning	LED
Gear in neutral	LED

Specification	Desc./Quantity
Side stand down	LED
Fuel reserve	LED
ABS	LED

Frame and suspensions

CHASSIS

Specification	Desc./Quantity
Type	Die-cast aluminium plates and high-strength steel tubular chassis.
Steering inclination angle	24.9°
Trail	109.6°

SUSPENSIONS

Specification	Desc./Quantity
Front	Upside-down hydraulic action telescopic fork, Ø 43 mm (1.69 in) stems
Travel	120 mm (4.72 in)
Rear	Oscillating swingarm and single adjustable hydraulic shock absorber
Wheel travel	122 mm (4.80 in)

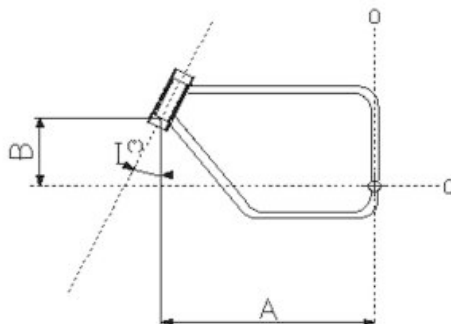

SIZES A AND B

Specification	Desc./Quantity
Size A	658.5 mm (25.93 in)
Size B	373.4 mm (14.70 in)

Brakes

BRAKES

Specification	Desc./Quantity
Front	Double floating disc, Ø 320 mm (12.60 in), radially-mounted callipers with four plungers- two of them Ø 27 mm (1.06 in), the other two Ø 32.03 (1.26 in) and 4 pads
Rear	Ø 240 mm (9.45 in) disc brake, Ø 35 mm (1.38 in) twin-plunger calliper

Wheels and tyres

WHEEL RIMS

Specification	Desc./Quantity
Type	Light alloy rims with extractable bolt
Front	3.50 x 17"
Rear	6.00 x 17"

TYRES

Specification	Desc./Quantity
Tyre type (standard)	DUNLOP SPORTMAX QUALIFIER - METZELER M3
Front	120/70 ZR17" (58W)
Inflation pressure	1 passenger: 2.3 bar (230 kPa) (33.36 PSI) 2 passengers: 2.5 bar (250 kPa) (36.26 PSI)
Rear	180/55 ZR17" (73W) or 190/50 ZR17" (73W)
Inflation pressure	1 passenger: 2.5 bar (250 kPa) (36.26 PSI) 2 passengers: 2.8 bar (280 kPa) (40.61 PSI)

Supply

FUEL SUPPLY SYSTEM

Specification	Desc./Quantity
Type	Electronic injection (Multipoint)
Throttle valves diameter	Ø 52 mm (2.05 in)
Fuel	Premium unleaded petrol, minimum octane rating of 95 (NORM) and 85 (NOMM)

Tightening Torques

FRAME ASSEMBLY

Name	Torque in Nm
TCEI screw fixing Shock Absorber Counterplate to right chassis bracket - M10x30 (1)	50 Nm (36.88 lbf ft)
TCEI screw fixing Fairings to engine - M12x282 (3)	80 Nm (59 lbf ft)
Self-tapping nut fixing left Fairing to engine and Framework to chassis fairings - M12 (7)	80 Nm (59 lbf ft)
TC TORX screw fixing Perimeter frame to the chassis fairings - M12x53 (4)	80 Nm (59 lbf ft)
TCEI upper screw fixing Saddle pillar to chassis - M8x30 (2)	25 Nm (18.44 lbf ft)
TCEI lower screw fixing Saddle pillar to chassis - M8x40 (2)	25 Nm (18.44 lbf ft)
Lower self-tapping nut fixing Saddle pillar to chassis - M8 (2)	25 Nm (18.44 lbf ft)
TCEI screw fixing lambda probe plate to right-side chassis (pre-fit on right fairing - M4x10 (2)	3 Nm (2.3 lbf ft)

FOOTREST UNIT

Name	Torque in Nm
TCEI sunken screw fixing Footrest Support to chassis - M8x30 (6)	18 Nm (13.27 lbf ft)
Non-slip bolt (fit on driver footrest) - M8 (2)	25 Nm (18.44 lbf ft)
Self-tapping TE screw for Footrest finish - M6x12 (8)	10 Nm (7.37 lbf ft)

STAND UNIT

Name	Torque in Nm
Screw for Stand - M10x1.25 (1)	10 Nm (10.34 lbf ft)
Lower nut - M10x1.25 (1)	30 Nm (22.13 lbf ft)
Self-tapping TE screw fixing Stand Plate on engine - M8x30 (3)	25 Nm (18.44 lbf ft)

SWINGARM UNIT

Name	Torque in Nm
TCEI screw Swing Arms coupling - M8x70 (7)	25 Nm (18.44 lbf ft)
Swingarm Pin adjustment Bushing (1)	12 Nm (8.85 lbf ft)
Swingarm Pin Ring Nut (1)	60 Nm (44.25 lbf ft)
Chain tensioner set screw (2)	-
SERPRESS nut (on chain tensioner pad set screw) - M8 (2)	-
TPSI screw fixing rear stand bushing - M6x40 (2)	10 Nm (7.37 lbf ft)
TBEI screw fixing chain tensioner pad - M5x12 (3)	3 Nm (2.21 lbf ft)
Self-tapping TBEI screw fixing chain guard, brake pipe protection and counterslider - M5x9 (5)	4 Nm (2.95 lbf ft)
Calliper support lock pin - M12 (1)	50 Nm (36.88 lbf ft) - Loctite 243

FRONT SUSPENSION UNIT

Name	Torque in Nm
Stainless steel TCC screw fixing fork stems on upper and lower plates - M8x30 (6)	25 Nm (18.44 lbf ft)
Headstock Ring nut - M25x1 (1)	7 Nm (5.16 lbf ft)
Headstock Cap - M22x1 (1)	100 Nm (73.75 lbf ft)
Screw (fasten on Fork Hub caps) - M8x40 (4)	25 Nm (18.44 lbf ft)
Screw fixing the stem in wheel carrier - M10x1.5 (2)	20 Nm (14.75 lbf ft)

REAR SUSPENSION UNIT

Name	Torque in Nm
TCEI screw - M10x50 (1)	50 Nm (36.88 lbf ft)
TCEI screw - M10x59 (1)	50 Nm (36.88 lbf ft)
Nut - M10 (1)	50 Nm (36.88 lbf ft)

ENGINE SMALL PARTS UNIT

Name	Torque in Nm
Self-tapping TE screw fixing negative on engine - M6x12 (3)	10 Nm (7.37 lbf ft)

FILTER CASE UNIT

Name	Torque in Nm
SWP Self-tapping screw - M2.9x12 TCCR (2)	3 Nm (2.21 lbf ft)
TCEI screw fixing negative on engine - M6x12 (1)	10 Nm (7.37 lbf ft)

FILTER CASING SMALL PARTS UNIT

Name	Torque in Nm
SWP Self-tapping Crosshead screw - M5x20 (21)	3 Nm (2.21 lbf ft)

EXHAUST SYSTEM UNIT

Name	Torque in Nm
SERPRESS self-locking nut fixing Plate on head - M8 (4)	25 Nm (18.44 lbf ft)
Primary Clamp (between front/rear manifolds and central manifold) - M6 (2)	7 Nm (5.16 lbf ft)
Silencer Clamp (between central manifold and silencer) - M6 (1)	7 Nm (5.16 lbf ft)
Self-tapping TE screw fixing Muffler holding Bracket to saddle pillar - M8x20 (2)	25 Nm (18.44 lbf ft)
Self-tapping TE screw fixing Silencer front attachment to muffler holding bracket - M8x35 (2)	35 Nm (25.81 lbf ft)
TBEI screw fixing right/left cover to silencer - M6x20 (4)	10 Nm (7.37 lbf ft)
TBEI lower screw fixing Licence Plate Holder curved support - M6x20 (2)	10 Nm (7.37 lbf ft)

COOLING SYSTEM UNIT

Name	Torque in Nm
Self-tapping TE screw fixing Radiator, left-side, to frame and radiator bracket to engine - M6x25 (2)	10 Nm (7.37 lbf ft)
Electric fan fixing screw (3)	3 Nm (2.21 lbf ft)
Screw fixing air deflector to radiator, right and left side (2)	10 Nm (7.37 lbf ft)

FRONT WHEEL UNIT

Name	Torque in Nm
Wheel Pin Nut (1)	80 Nm (59 lbf ft)
Self-tapping TE screw fixing front Disc - M8x20 =S= (12)	30 Nm (22.13 lbf ft) (Loctite 243)

REAR WHEEL UNIT

Name	Torque in Nm
Self-tapping TE screw fixing rear Disc - M8x20 =S= (5)	30 Nm (22.13 lbf ft) (Loctite 243)
TCEI screw fixing Anti-vibration buffer on wheel - M10x30 (5)	50 Nm (36.88 lbf ft) (Loctite 2701)
Lower Self-locking nut fixing Crown to sprocket carrier - M10 (5)	50 Nm (36.88 lbf ft)
Wheel Pin Nut - M25x1.5 (1)	120 Nm (88.5 lbf ft)

FRONT BRAKE UNIT

Name	Torque in Nm
Brake pipe union fixing pipe to pump - M10x1 (1)	25 Nm (18.44 lbf ft)
Filler with bleed (Heng Tong) - M10x1 (2)	25 Nm (18.44 lbf ft)
Self-tapping TE screw fixing Calliper - M10x1.25x55 (4)	50 Nm (36.88 lbf ft)

REAR BRAKE UNIT

Name	Torque in Nm
TCEI screw fixing Pin to brake lever - M6x16 (1)	10 Nm (7.37 lbf ft)
Rear brake Lever pin - M6 (1)	25 Nm (18.44 lbf ft)
Brake pipe union - M10x1 (2)	25 Nm (18.44 lbf ft)
Lock nut for fork - M6 (1)	10 Nm (7.37 lbf ft)
Self-tapping TE screw fixing Pump to footrest support - M6x20 (2)	10 Nm (7.37 lbf ft)
TBEI screw fixing oil pipe to swingarm and rubber pipe to footrest support - M5x12 (4)	6 Nm (4.42 lbf ft)
Self-locking nut - M6 (1)	10 Nm (7.37 lbf ft)
Self-tapping TE screw - M6x16 (1)	10 Nm (7.37 lbf ft)

HANDLEBAR / CONTROLS / TRASM. UNIT

Name	Torque in Nm
Anti-vibration weight terminal - M8x1 (2)	35 Nm (25.81 lbf ft)
TCEI screw - M6x40 (2)	10 Nm (7.37 lbf ft)
RH light switch (1)	2.5 Nm (1.47 lbf ft)
LH light switch (1)	2.5 Nm (1.47 lbf ft)
TCEI screw fixing lower U-bolt on fork plate - M10x60 (2)	50 Nm (36.88 lbf ft)
Stainless steel TCC screw fixing upper to lower U-bolt - M8x25 (4)	25 Nm (18.44 lbf ft)

ELECTRICAL COMPONENTS UNIT

Name	Torque in Nm
SWP Self-tapping screw fixing Demand Support to Demand - M5x14 (4)	3 Nm (2.21 lbf ft)
Self-tapping TE screw fixing Demand sensor to chassis - M6x20 (3)	10 Nm (7.37 lbf ft)

LIGHTS UNIT / INSTRUMENT PANEL

Name	Torque in Nm
SWP Self-tapping screw fixing Instrument Panel - M5x14 (6)	3 Nm (2.21 lbf ft)
Special screw fixing steering head with Instrument panel supporting plate - M6 (2)	10 Nm (7.37 lbf ft)
TCEI screw fixing steering head with Instrument panel supporting plate - M6x16 (4)	10 Nm (7.37 lbf ft)
Self-locking nut - M6 (3)	10 Nm (7.37 lbf ft)
TBEI screw fixing Headlight bracket to steering base - M6x15 (2)	10 Nm (7.37 lbf ft)
Lower TBEI screw fixing Rear Light - M5 (1)	4 Nm (2.95 lbf ft)
Lower TCB screw fixing Rear Light - M4.2x20 (2)	4 Nm (2.95 lbf ft)
Self-locking nut - M6 (4)	3 Nm (2.21 lbf ft)

TANK UNIT

Name	Torque in Nm
Self-locking nut - M5 (6)	6 Nm (4.42 lbf ft)
Self-tapping TE screw - M6x30 (2)	6 Nm (4.42 lbf ft)

FRONT BODYWORK UNIT

Name	Torque in Nm
TBEI screw fixing Under grab handles/ Tail sections / Saddle Pillar - M5x16 (2)	4 Nm (2.95 lbf ft)
Self-tapping TBEI screw - M5 (7)	3 Nm (2.21 lbf ft)
SWP Self-tapping Crosshead screw fixing Tail sections to battery compartment and to fairings - M5x20 (6)	4 Nm (2.95 lbf ft)
Self-tapping TE screw fixing Grab handle - M8x20 (4)	25 Nm (18.44 lbf ft)
TCB screw fixing battery Cover - M4x16 (2)	3 Nm (2.21 lbf ft)
TBEI screw fixing Mudguard to appendix - M5x9 (2)	3 Nm (2.21 lbf ft)
TBEI screw fixing Mudguard to stems - M5x9 (4)	4 Nm (2.95 lbf ft)
TBEI screw fixing battery compartment to saddle pillar - M6 (2)	5 Nm (3.69 lbf ft)
TBEI screw - M5x9 (14)	3 Nm (2.21 lbf ft)
TBEI screw fixing air deflectors to radiator - M6x16 (2)	7 Nm (5.16 lbf ft)

FINISHING SMALL PARTS UNIT

Name	Torque in Nm
TCEI screw - M8x40 (1)	25 Nm (18.44 lbf ft)
Self-tapping TE screw - M6x25 (2)	10 Nm (7.37 lbf ft)
TCE screw fixing fuel cap - M5x16 (4)	5 Nm (3.69 lbf ft)
TCEI screw fixing fuel cap - M5x30 (3)	5 Nm (3.69 lbf ft)
TCEI screw fixing saddle lock to tail section - M5x16 (2)	4 Nm (2.95 lbf ft)

ENGINE UNIT

Name	Torque in Nm
TCEI screw fixing Pin to gearbox lever and Gearbox Lever to knurled shaft- M6x16 (2)	10 Nm (7.37 lbf ft)
Left lock nut for ball joint - M6 (1)	10 Nm (7.37 lbf ft)
Lock nut for ball joint - M6 (1)	10 Nm (7.37 lbf ft)
Pin fixing screw (2)	-
Countersunk screw fixing pin (1)	-
Brake pipe union fixing pipe to pump - M10x1 (1)	25 Nm (18.44 lbf ft)
Filler with bleed (Heng Tong) fixing pipe to pin - M10x1 (1)	25 Nm (18.44 lbf ft)
Self-tapping TE screw fixing Pinion - M10x1.25x55 (1)	50 Nm (36.88 lbf ft) - Loctite 243

COMPLETE HEAD

Name	Torque in Nm
Cam cap/head fixing screws - M6 (16)	Pre-tightening: (4.90 - 6.86) Nm ((3.61 - 5.06) lbf ft) Tightening: (9.81 - 12.75) Nm ((7.24 - 9.40) lbf ft)

Name	Torque in Nm
Map sensor fitting (brass) (2)	2 Nm (1.48 lbf ft) (Loctite 243)
Map sensor fitting (steel) (2)	3.50 Nm (2.58 lbf ft) (Loctite 243)
H2O Bleed fitting (brass) (1)	2 Nm (1.48 lbf ft) (Loctite 243)
H2O Bleed fitting (steel) (1)	3.50 Nm (2.58 lbf ft) (Loctite 243)
Cap - M6 (1)	To fit flush
Oil cap - M10x1.25 (2)	7 Nm (5.16 lbf ft) (3M SCOTCH GRIP 2353)
Screw fixing fitting to bleed - M5 (4)	5.50 Nm (4.06 lbf ft)
Special screw fixing Head Cover - M6 (8)	8 Nm (5.90 lbf ft)
H2O Temperature sensor - M12x1.5 (1)	23 Nm (16.96 lbf ft)
Water sensor housing threaded cap - M12x1.5 (1)	10 Nm (7.38 lbf ft) (Loctite Drise AL 506)
Nut fixing Stud Bolts to Head - M10x1.25 (8)	Pre-torque 10 Nm (7.38 lbf ft) - Torque 13 Nm (9.59 lbf ft) + 90° + 90° (Lubricate threads before tightening)
Head / Cylinder / Crankcase internal side retainer - M6 (4)	12 Nm (8.85 lbf ft)
Head / Cylinder / crankcase external side retainer - M6 (2)	12 Nm (8.85 lbf ft)
Nut fixing Stud Bolts to Head - M6 (4)	12 Nm (8.85 lbf ft)
Nut fixing Stud Bolts to Head - M8 (2)	26 Nm (19.18 lbf ft)
Spark plug (2)	13 Nm (9.59 lbf ft)
Screw fixing Pencil to Eldor coil - M6 (2)	5.50 Nm (4.06 lbf ft)
Screw fixing camshaft retaining plate - torx M3 (8)	3 Nm (2.21 lbf ft) (Loctite 270)
Camshaft locking threaded cap	11 Nm (8.11 lbf ft)

TIMING SYSTEM

Name	Torque in Nm
Nut fixing camshaft gears (pre-tightening) - M15x1 (4)	30 Nm (22.13 lbf ft)
Nut fixing camshaft gears - M15x1 (4)	90 Nm (66.38 lbf ft)
Screw fixing Timing system Gear - M24x1.5 (2)	40 Nm (29.50 lbf ft) (3M SCOTCH GRIP 2353)
Special screw fixing Mobile / Fixed Pads - M8 (4)	19 Nm (14.01 lbf ft) (Loctite 242)
Chain tensioner fixing screw - M6 (4)	12 Nm (8.85 lbf ft)
Cylinder Plate fixing screw - M6 (4)	12 Nm (8.85 lbf ft)
Screw for Chain tensioner adjustment - M6 (2)	5.50 Nm (4.06 lbf ft)

COMPLETE CRANKCASE AND OTHER ELEMENTS

Name	Torque in Nm
Oil drainage plug - M16x1.5	19 Nm (14.01 lbf ft)
Special screw for oil calibration on flywheel side crankcase half - M10x1 (1)	16 Nm (11.80 lbf ft)
Conical cap for crankshaft support lubrication - M8x1 (4)	15 Nm (11.06 lbf ft)
Brass Calibrated dowel fixed on crankcase unit - M8 (2)	5.50 Nm (4.06 lbf ft)
Screw fixing piston oil Jet - M5 (2)	5.50 Nm (4.06 lbf ft) (Loctite 242)
Screw fixing Gear sensor - M5 (2)	5.50 Nm (4.06 lbf ft) (Loctite 243)
Screw fixing Revolution sensor - M6 (1)	5.50 Nm (4.06 lbf ft) (Loctite 243)
Tone Wheel tightening on Secondary Transmission Shaft - M16x1 (1)	43 Nm (31.72 lbf ft) (Loctite 270)
Oil pressure adjustment valve, 3/4" Unf 16 (1)	43 Nm (31.72 lbf ft)
Oil Pump fixing screw - M6 (2)	5.50 Nm (4.06 lbf ft) (Loctite 242)
Screw fixing Oil Pump Cover - M3 (2)	0.80 Nm (0.59 lbf ft)
Screw fixing oil Pump with Gear - M5 (1)	8 Nm (5.90 lbf ft) (Loctite 270)

Name	Torque in Nm
Screw fixing Gear locking pawl - M6 (1)	12 Nm (8.85 lbf ft)
Screw fixing Desmodromic / Sprocket Selector - M8 (1)	23 Nm (16.96 lbf ft)
Selector Plate fixing screw - M5 (3)	5.50 Nm (4.06 lbf ft)
Selector pin retainer on clutch side crankcase half - M10x1.5 (1)	16 Nm (11.80 lbf ft)
Screw fixing clutch / flywheel side crankcase half - M6 (8)	12 Nm (8.85 lbf ft)
Screw fixing clutch / flywheel side crankcase half - M8 (9)	26 Nm (19.18 lbf ft)
Oil sensor retainer on clutch side crankcase half (1)	13 Nm (9.59 lbf ft)
Suction rose fixing screw (2)	12 Nm (8.85 lbf ft)
Oil Filter fitting retainer on clutch side crankcase half (1)	20 Nm (14.75 lbf ft)
Oil filter (1)	14 Nm (10.33 lbf ft)
Screw fixing bearing retainer - M6 (3)	10 Nm (7.38 lbf ft) (Loctite 270)

SHAFT / FLYWHEEL / CLUTCH

Name	Torque in Nm
Nut fixing Crankshaft primaries - M24x1.5 (1)	270 Nm (199.14 lbf ft)
Freewheel ring fixing screw - M6 (6)	14 Nm (10.33 lbf ft) (Loctite 242)
Screw fixing Rotor - Crankshaft - M12x1.25 (1)	120 Nm (88.51 lbf ft)
Screw fixing Retaining Plate - M5 (1)	8 Nm (5.90 lbf ft)
Clutch fixing nut - M24x1.5 (1)	180 Nm (132.76 lbf ft) (Caulking)
Clutch spring fixing screw - M6 (6)	12 Nm (8.85 lbf ft)
Self-tapping TE screw fixing Pinion - M10x1.25x55 (1)	50 Nm (36.88 lbf ft)
Connecting rod screw - M10 (4)	20 + 50 + 70 Nm (14.75 + 36.89 + 51.63 lbf ft) (Lubricate threads before tightening)

FLYWHEEL COVERS / CLUTCH

Name	Torque in Nm
Screw fixing Stator / Flywheel Cover - M6 (3)	9 Nm (6.64 lbf ft)
Screw fixing Pick-up / Flywheel Cover - M5 (2)	3.50 Nm (2.58 lbf ft)
Screw fixing Flywheel Cover - M6 (11)	12 Nm (8.85 lbf ft)
Nut fixing Shaft pump Control inlet - M6 (1)	12 Nm (8.85 lbf ft) (Loctite 244)
Oil drainage cap retainer on Clutch Cover (1)	2 Nm (1.48 lbf ft)
Screw fixing Clutch side Cover - M6 (13)	12 Nm (8.85 lbf ft)
Screw fixing Pump Cover / Clutch side Cover - M6 (3)	12 Nm (8.85 lbf ft)
Screw fixing Pump Cover / Clutch Cover / clutch side crankcase half - M6 (2)	12 Nm (8.85 lbf ft)
Screw fixing Clutch Cover / Clutch side Cover - M6 (6)	12 Nm (8.85 lbf ft)
Screw fixing "split" clutch cover gasket retainer - M4 steel A2 (6)	3 Nm (2.21 lbf ft)
Screw fixing Plate / Clutch Control Support - M5 (3)	5.50 Nm (4.06 lbf ft)
Screw fixing Clutch Control Support / flywheel side crankcase half - M6 (1)	12 Nm (8.85 lbf ft)
Screw fixing Clutch Control Support / flywheel side crankcase half - M6 (2)	12 Nm (8.85 lbf ft)
Screw fixing Bracket / Starter motor - M6 (2)	12 Nm (8.85 lbf ft)

Name	Torque in Nm
Screw fixing engine Bracket / clutch side crank-case half - M6 (2)	12 Nm (8.85 lbf ft)
Crankshaft access cover (1)	4 Nm (2.95 lbf ft)
H2O Pump Rotor (1)	4.50 Nm (3.32 lbf ft)
Screw fixing Stick-coil / Head cover - M6 (2)	5.50 Nm (4.06 lbf ft)
Screw fixing plate / "split" clutch cover - M4 steel A2 (6)	3 Nm (2.21 lbf ft) (Loctite 243)

THROTTLE BODY / FILTER HOUSING

Name	Torque in Nm
Intake Fitting fixing screw - M6 (8)	12 Nm (8.85 lbf ft) (Loctite 242)
Screw fixing Injection Throttle Body - M6 (8)	12 Nm (8.85 lbf ft) (Loctite 242)
rbw control unit fixing screw - M5 (2)	3.50 Nm (2.58 lbf ft) (Loctite 242)
Injectors fixing screw - M6 (2)	12 Nm (8.85 lbf ft) (Loctite 242)
Crosshead self-tapping screw fixing cover/ filter casing - M5x20 (8)	3 Nm (2.21 lbf ft)
Crosshead self-tapping screw fixing partition / filter casing - M5x20 (10)	3 Nm (2.21 lbf ft)
Crosshead self-tapping screw fixing side cover / filter casing - M5x20 (3)	3 Nm (2.21 lbf ft)
Crosshead self-tapping screw 5x10 (2)	3 Nm (2.21 lbf ft)

Overhaul data

Assembly clearances

Cylinder - piston assy.

The pistons are available in four size types (A, B, C, D) to be coupled to the four cylinder types (A, B, C, D).

Only one type of piston ring is available.

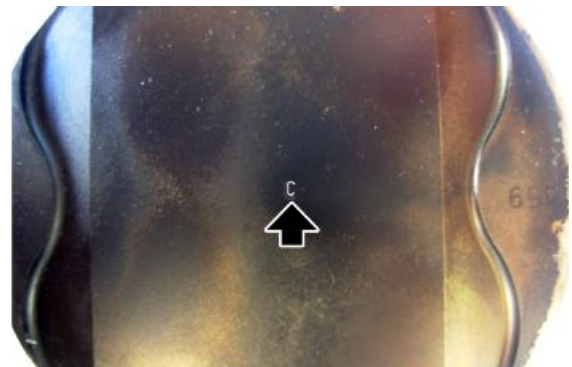

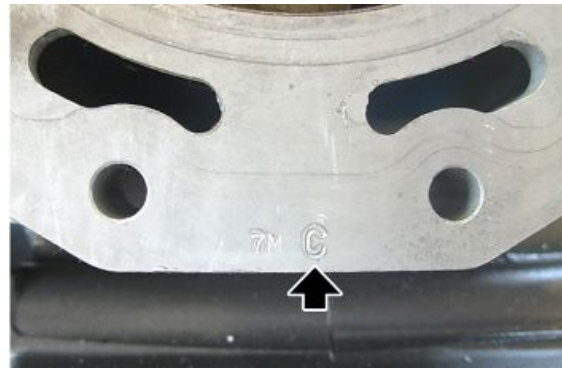

CYLINDER - PISTON COUPLING

Specification	Desc./Quantity
Piston - cylinder coupling Type A	Cylinder: 91.990 - 91.977 mm (3.6216 - 3.6219 in) Piston: 91.933 - 91.940 mm (3.6217 - 3.6197 in)
Piston - cylinder coupling Type B	Cylinder: 91.997 - 92.004 mm (3.6219 - 3.6222 in) Piston: 91.940 - 91.947 mm (3.6197 - 3.6199 in)
Piston - cylinder coupling Type C	Cylinder: 92.004 - 92.011 mm (3.6222 - 3.6225 in) Piston: 91.947 - 91.954 mm (3.6199 - 3.6202 in)
Piston - cylinder coupling Type D	Cylinder: 92.011 - 92.018 mm (3.6225 - 3.6227 in) Piston: 91.954 - 91.961 mm (3.6202 - 3.6205 in)
Fitting clearance	0.050 - 0.064 mm (0.00197 - 0.00252 in)

Crankcase - crankshaft - connecting rod

Two types of crankcase (1 or 2) are determined according to the diameter of the bearing hole. The types are written on the engine crankshaft with a felt-tip pen and can be seen by removing the clutch cover and the flywheel cover.

- Two letters representing the main bushings and the primary wheelbase are written on the clutch side.
- A letter indicating the main bushing type is written on the flywheel side.

CRANKCASE SELECTION TYPE

Specification	Desc./Quantity
Crankcase type 1	Bushing seat diameter: 53.954 - 53.960 mm (2.1241 - 2.1244 in)
Crankcase type 2	Bushing seat diameter: 53.960 - 53.966 mm (2.1244 - 2.1246 in)

There are two types of crankshaft for each bearing:

- 4 - 5 for flywheel side;
- 7 - 8 for clutch side.

The category type is stamped on one crankshaft counterweight.

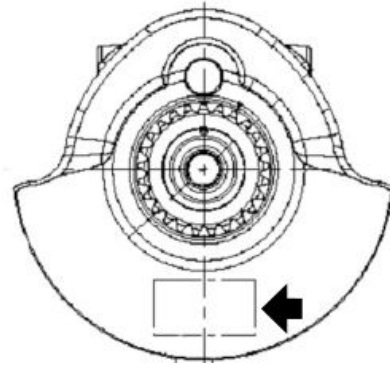

NOTE

THE SHAFT MAY HAVE TWO DIFFERENT CLASSES ON THE TWO BEARINGS.

CRANKSHAFT SELECTION TYPE

Specification	Desc./Quantity
Crankshaft type 4 - 7	Main journals - diameter: 49.978 - 49.984 mm (1.9676 - 1.9679 in)
Crankshaft type 5 - 8	Main journals - diameter: 49.972 - 49.978 mm (1.9674 - 1.9676 in)

Once the categories below are checked:

- crankcase
- flywheel side main journal
- clutch side main journal

choose the bushings to be used for coupling according to the following table.

MAIN BUSHINGS

Specification	Desc./Quantity
Main journal type 4 (flywheel side)	crankcase type 1 - half-bushings A (red)
Main journal type 4 (flywheel side)	crankcase type 2 - half-bushings B (blue)
Main journal type 5 (flywheel side)	crankcase type 1 - half-bushings B (blue)
Main journal type 5 (flywheel side)	crankcase type 2 - half-bushings C (yellow)
Main journal type 7 (clutch side)	crankcase type 1 - half-bushings A (red)
Main journal type 7 (clutch side)	crankcase type 2 - half-bushings B (blue)
Main journal type 8 (clutch side)	crankcase type 1 - half-bushings B (blue)
Main journal type 8 (clutch side)	crankcase type 2 - half-bushings C (yellow)

Crankcase category

Crankcase can be selected from two types (A or B) according to the centre to centre distance between the primary reduction gears.

The category can be checked out on clutch-side crankcase half, at the back.

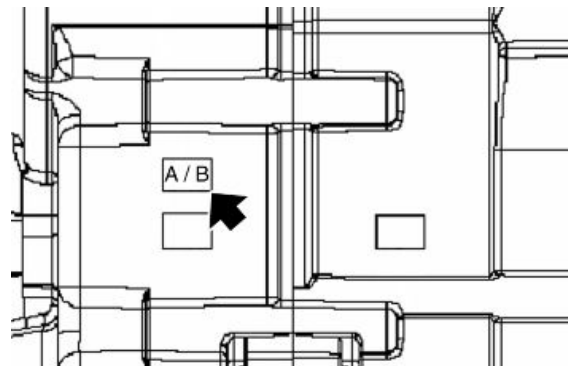

NOTE

SHOULD THE CRANKCASE BE REPLACED, THIS IS SUPPLIED WITH THE PRIMARY REDUCTION GEAR ALREADY COUPLED.

CRANKCASE SELECTION TYPE

Specification	Desc./Quantity
Type A crankcase	Centre to centre distance: 110.50 - 110.54 mm (4.3504 - 4.3519 in)
Type B crankcase	Centre to centre distance: 110.46 - 110.50 mm (4.3488 - 4.3504 in)

Primary category

Pinion can be selected from two types (A or B) according to the centre to centre distance between the primary reduction gears.

The category can be checked out on the pinion itself.

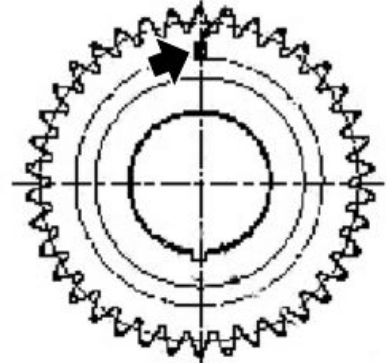

Crankshaft category

Shaft can be selected from two types (1 or 2) according to the crank pin diameter.

Shaft can be selected from seven types (E1, E2, ...) according to connecting rod weight.

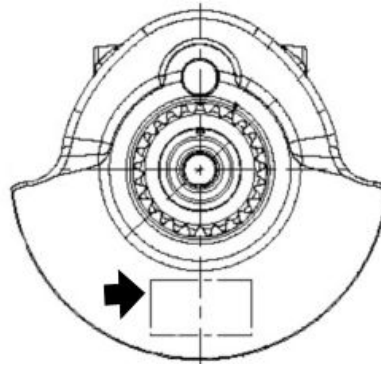

CRANKSHAFT SELECTION TYPE

Specification	Desc./Quantity
Crankshaft type 1	Crank pin diameter: 41.994 - 42.000 mm (1.65330 - 1.65354 in)
Crankshaft type 2	Crank pin diameter: 41.988 - 41.994 mm (1.65307 - 1.65330 in)

Bushing selection

The connecting rod has only one size category. Therefore, bushings are chosen only based on crankshaft type.

BUSHINGS

Specification	Desc./Quantity
Crankshaft type 1	Connecting rod type 1: half-bushings A (red)
Crankshaft type 2	Connecting rod type 1: half-bushings B (blue)

Connecting rod selection

Not all weight types are available as spare parts; only the main two. Refer to the following table for your choice:

CONNECTING RODS

Specification	Desc./Quantity
Type E1 crankshaft	Original connecting rod type: brown Spare connecting rod type: brown
Type E2 crankshaft	Original connecting rod type: blue Spare connecting rod type: blue
Type E3 crankshaft	Original connecting rod type: yellow Spare connecting rod type: yellow
Type E4 crankshaft	Original connecting rod type: green Spare connecting rod type: green
Type E5 crankshaft	Original connecting rod type: pink Spare connecting rod type: pink
Type E6 crankshaft	Original connecting rod type: black Spare connecting rod type: black
Type E7 crankshaft	Original connecting rod type: white Spare connecting rod type: white

CAUTION

THE CONNECTING RODS OF THE SAME CRANKSHAFT MUST BE THE SAME COLOUR AND HAVE THE SAME TYPE OF COUPLING AS THE CRANKSHAFT. UPON REFITTING, MAKE SURE THAT THE HALF-BUSHINGS ARE OF THE SAME TYPE.

See also

[Removing the clutch cover](#)

[Removing the flywheel cover](#)

Recommended products chart**RECOMMENDED PRODUCTS**



Product	Description	Specifications
AGIP RACING 4T, SAE 15W-50	Engine oil	Use top-branded oils that meet or exceed the requirements of API SJ/CCMC G4/ACEA A3-04/ JASO MA specifications.
AGIP FORK 5W	Fork oil	SAE 5W
AGIP MP GREASE	Grease for bearings, joints, couplings and levers	Alternatively to the recommended product, use top-branded grease for roller bearings, useful temperature range: -30°C... +140°C (-22°F...+284°F), drop point: 150°C...230°C (302°F... 446°F), high anticorrosive protection, good water and rust resistance.
AGIP CHAIN GREASE SPRAY	Recommended CHAIN oil	Grease
AGIP BRAKE 4 / BRAKE 5.1	Recommended BRAKE FLUID	-
AGIP BRAKE 4 / BRAKE 5.1	Recommended CLUTCH FLUID	-
SPECIAL AGIP PERMANENT fluid	Recommended ENGINE COOLANT	Biodegradable coolant, ready for use, with "long life" technology and characteristics (pink). Freezing protection up to -40°C (-104°F). According to CUNA 956-16 standard.



INDEX OF TOPICS

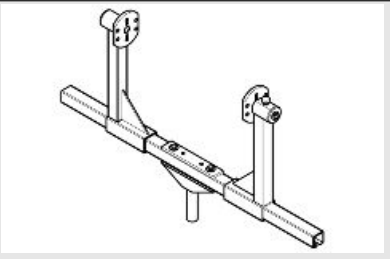
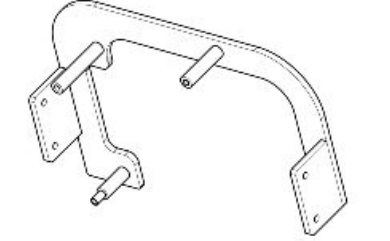
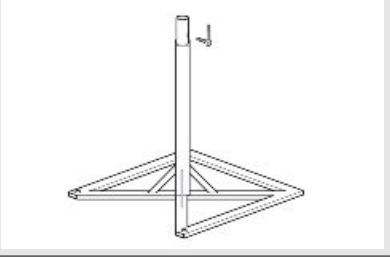
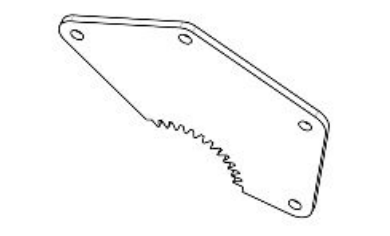
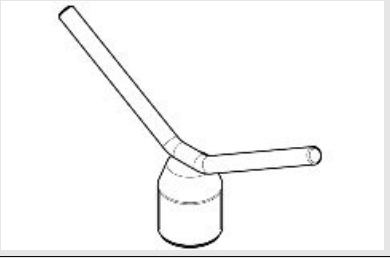
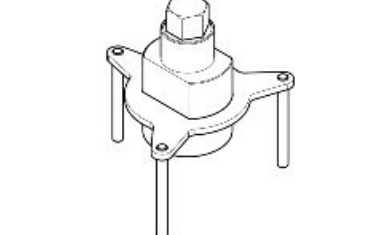

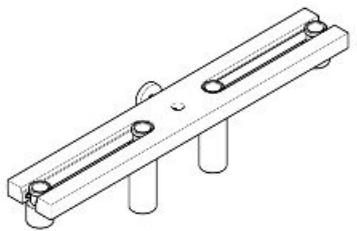
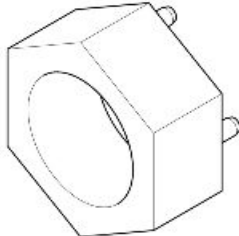
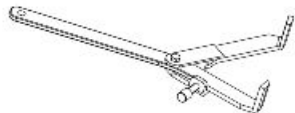
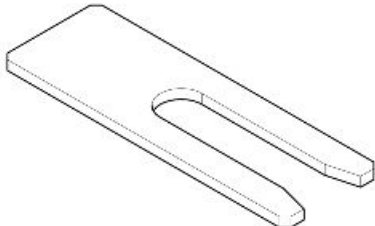
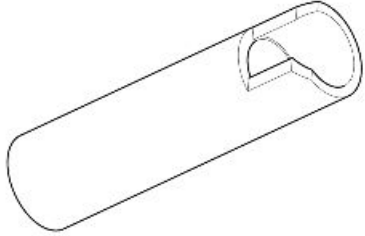

SPECIAL TOOLS

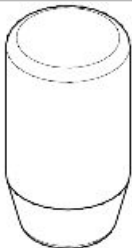
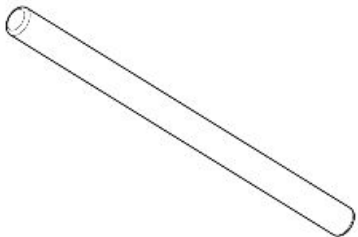
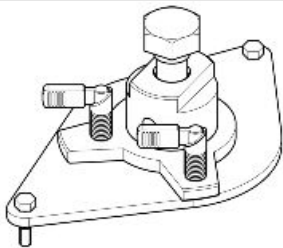
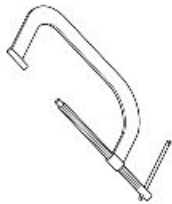
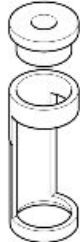
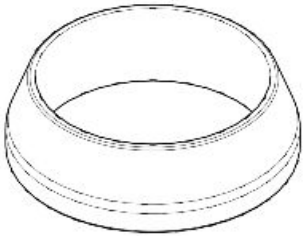

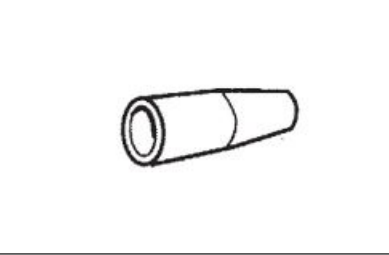

S-TOOLS

		SPECIAL TOOLS	
Stores code		Description	
020709Y		Engine support	
020710Y		Engine plate	
AP8140187		Engine support stand	
020711Y		Engine pinion locking	
020712Y		Handle for Flywheel cover removal	
020713Y		Flywheel extractor	



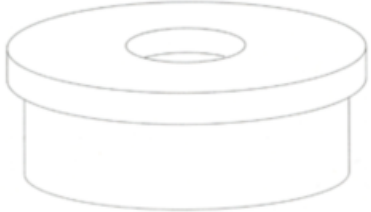
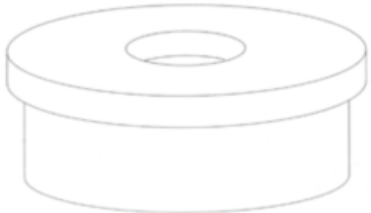

Stores code	Description	
020714Y	Comparator support	
020715Y	Tone wheel removal	
9100896	Clutch bell locking tool	
020716Y	Connecting rod locking	
020717Y	Piston ring driver	
AP8140302	tool for sealing ring fitting	

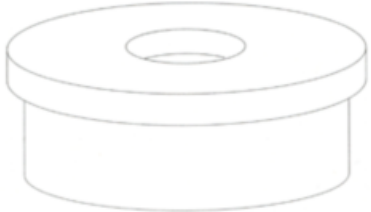
Stores code	Description	
020718Y	Camshaft gear alignment pin	
020719Y	Timing pin	
020720Y	Timing tool	
AP8140179	Valve spring compressor	
020721Y	Adaptor for valve removal	
020722Y	Guide for oil seal	
020376Y	Punch adaptor	

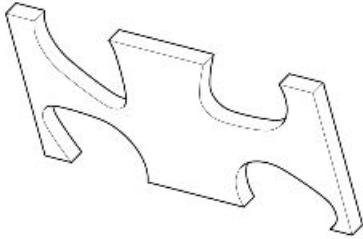
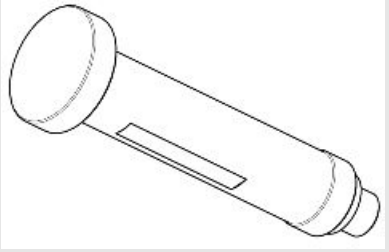
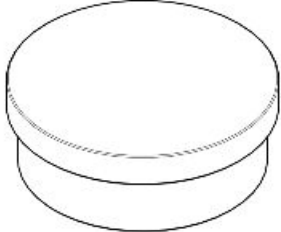
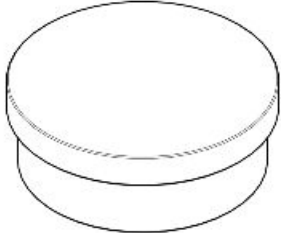
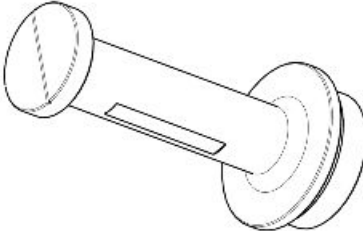
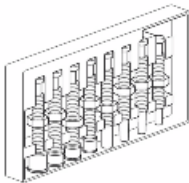
Stores code	Description	
020629Y	8 mm (0.31 in) guide	
020412Y	15-mm Oil seal guide	
020439Y	17-mm guide for oil seal	
020263Y	Sheath for fitting the driven pulley	
020365Y	22 mm (0.87 in) guide	
020364Y	25 mm oil seal guide	

Stores code	Description	
020483Y	30 mm punch	
020441Y	Oil seal punch	
020358Y	37 x 40 mm punch	
020357Y	32 x 35 mm adaptor	
020359Y	42 x 47 mm punch	
020360Y	52 x 55 mm punch	

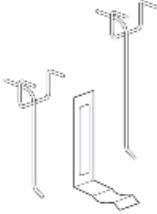
Stores code	Description	
020723Y	Template for timing overhead camshafts	
020724Y	Gear control rod roller cage punch	
020725Y	Punch for water pump overall sealing	
020726Y	Extractor for bushings	
020727Y	Punch for bushings	
8140180	Extractor for bushings	

Stores code	Description	
8140181	manometer for fuel - oil - compression pressure	
8140199	Tool panel	
8202222	Generic adhesive film for panel	
8140426	Hooks for panel	
XXXXXXX	Tool for inserting the entire rotor shaft (being coded)	

INDEX OF TOPICS

MAINTENANCE

MAIN

Maintenance chart

Adequate maintenance is fundamental to ensuring long-lasting, optimum operation and performance of your vehicle.

To this end, aprilia offers a set of checks and maintenance services (at the owner's expense) that are summarised in the table shown on the following page. Any minor faults should be reported without delay to an **Authorised aprilia Dealer or Sub-Dealer** without waiting until the next scheduled service to solve it.

All scheduled maintenance services must be carried out at the specified times and kilometres, even if the stated mileage has not yet been reached. Carrying out scheduled services on time is essential to ensure your warranty remains valid. For further information regarding Warranty procedures and "Scheduled Maintenance", please refer to the "Warranty Booklet".

NOTE

CARRY OUT MAINTENANCE OPERATIONS AT HALF THE INTERVALS SHOWN IF THE VEHICLE IS USED IN WET OR DUSTY AREAS, OFF ROAD OR FOR SPORTING APPLICATIONS.

AT EVERY START-UP

Action

Warning light indicating error on the instrument panel - check

AFTER RUN-IN (1000 KM (625 MI))

Action

Gearing chain - Check and lubricate or replace if necessary

Transmission cables and controls - Check and clean, adjust, grease or replace if necessary

Steering bearings and steering clearance - Check and clean, adjust, grease or replace if necessary.

Control unit diagnosis - Check

Disc brakes - Check and clean, adjust or replace if necessary

Engine oil filter - Replace

General vehicle operation - Check and clean, adjust, grease or replace if necessary.

Valve clearance - Check and adjustment

Braking systems - Check and clean, adjust, grease or replace if necessary

Light circuit - Check and clean, adjust or replace if necessary

Clutch lever fluid - check and top-up if necessary

Brake fluid - check

Coolant - Check and top-up

Engine oil - Change

Tyres - Check and clean, adjust, grease or replace if necessary

Tyre pressure - Adjust

Wheels - Check and clean, adjust, grease or replace if necessary

Bolts, nuts and screws tightening - Check and clean, adjust, grease or replace if necessary

Suspensions and setting - Check and clean, adjust, grease or replace if necessary

Brake pad wear - Check and clean, adjust or replace if necessary

EVERY 1000 KM (625 MI)

Action

Gearing chain tension and lubrication - check and clean, adjust, grease or replace if necessary

EVERY 5000 KM (3100 MI) OR 1 MONTH**Action**

Tyre pressure and wear - check

EVERY 5000 KM (3100 MI)**Action**

Brake pad wear - Check and clean, adjust or replace if necessary

EVERY 10,000 KM (6,215 MI)**Action**

Air filter - Check and clean, replace if necessary

EVERY 20,000 KM (12,500 MILES) OR 24 MONTHS**Action**

Rear shock absorber - Check

Spark plug - Replace

Gearing chain - Check and lubricate or replace if necessary

Transmission cables and controls - Check and clean, adjust, grease or replace if necessary

Steering bearings and steering clearance - Check and clean, adjust, grease or replace if necessary.

Wheel bearings - Check and clean, adjust, grease or replace if necessary

Control unit diagnosis - Check

Disc brakes - Check and clean, adjust or replace if necessary

Air filter - Replace

Engine oil filter - Replace

Fork - Check and clean, adjust and lubricate

General vehicle operation - Check and clean, adjust, grease or replace if necessary.

Cooling system - check and clean, adjust, grease or replace if necessary.

Braking systems - Check and clean, adjust, grease or replace if necessary

Light circuit - Check and clean, adjust or replace if necessary

Safety switches - Check and clean, adjust, grease or replace if necessary

Clutch lever fluid - check and top-up if necessary

Brake fluid - Check

Coolant - Check and top-up

Engine oil - Change

Light aiming - Check

Fork oil seals - Check and clean, replace if necessary

Anti-vibration buffer - check and replace if necessary

Valve clearance adjustment - Adjust

Wheels - Check and clean, adjust, grease or replace if necessary

Bolts, nuts and screws tightening - Check and clean, adjust, grease or replace if necessary

Suspensions and setting - Check and clean, adjust, grease or replace if necessary

Fuel pipes - Check and clean, adjust, grease or replace if necessary

Clutch wear - Check and replace if necessary

Brake pad wear - Check and clean, adjust or replace if necessary

EVERY 24 MONTHS**Action**

Clutch control fluid - Replace

Brake fluid - Change

Coolant - Change

Fork oil - Change

EVERY 4 YEARS**Action**

Fuel pipes - Replace

Spark plug

At regular intervals, remove the spark plug and clean off any carbon deposits or replace as required.

CAUTION

ALWAYS REPLACE BOTH SPARK PLUGS, EVEN IF ONLY ONE NEEDS REPLACING.

- Remove the saddle.
- Remove the side fairings.

In order to gain access to the spark plugs:

CAUTION

BEFORE CARRYING OUT THE FOLLOWING OPERATIONS AND IN ORDER TO AVOID BURNS, LEAVE THE ENGINE AND MUFFLER TO COOL OFF TO AMBIENT TEMPERATURE.

FRONT SPARK PLUG

- Working on the left side of the vehicle, undo and remove the screw and collect the washer.



- Undo and remove the screw.



- Detach the radiator towards the vehicle right-hand side and lower it so as to be able to work on the coil.



- Undo and remove the screw.



- Slide off the front coil.



- Unscrew and remove the front spark plug.



- Working from both sides, undo and remove the screw.



- Remove at least one side air deflector.
- Slide off the key lock plate.



- Undo and remove the two screws and collect the two collars.
- Undo and remove the chamber fixing screws.
- Slide off the "too full" and breather pipes from the chamber.
- Lift the tank by turning it on the hinge.
- Release the petrol pipe.
- Disconnect the pump cable harness.



- Working on the right side, unscrew and remove the nut and slide off the bolt from the left side.



- Lift the tank.
- Undo and remove the rear coil fixing screw.



- Slide off the rear coil.
- Unscrew and slide off the rear spark plug.



- Check the gap between the electrodes with a feeler thickness gauge.

CAUTION

DO NOT ATTEMPT TO READJUST THE ELECTRODE GAP.

0,6 - 0,7 mm (0.023 - 0.027 in)

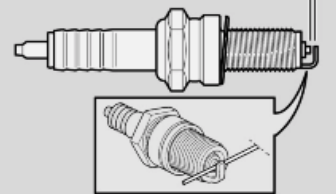

The gap between the electrodes should be between 0.7 ÷ 0.8 mm (0.027 ÷ 0.031 in). Otherwise, replace the spark plug (2).

- Make sure the washer is in good conditions.

Installation:

- Once the washer is fitted, screw the spark plug (2) carefully to avoid damaging the thread.
- Tighten using the spanner supplied in the tool kit. Make each spark plug (2)

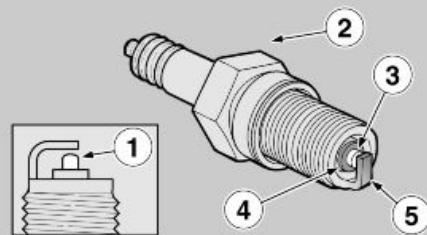

complete 1/2 of a turn to compress the washer.

CAUTION

IT IS ESSENTIAL TO TIGHTEN THE SPARK PLUG (2) PROPERLY. A LOOSE SPARK PLUG MAY CAUSE ENGINE OVERHEATING AND RESULT IN SEVERE DAMAGE.

Locking torques (N*m)

Spark plug (2) 13 Nm (9.59 lbf ft)

Engine oil

Check

Check the engine oil level frequently.

NOTE

CARRY OUT MAINTENANCE OPERATIONS AT HALF THE INTERVALS SHOWN IF THE VEHICLE IS USED IN WET OR DUSTY AREAS, OFF ROAD OR FOR SPORTING APPLICATIONS.



ENGINE OIL LEVEL MUST BE CHECKED WHEN THE ENGINE IS WARM. IF YOU CHECK LEVEL WHEN THE ENGINE IS COLD, OIL LEVEL COULD TEMPORARILY DROP BELOW THE "MIN" MARK. THIS SHOULD NOT BE CONSIDERED A PROBLEM PROVIDED THAT THE ALARM WARNING LIGHT AND THE ENGINE OIL PRESSURE ICON ON THE DISPLAY DO NOT TURN ON SIMULTANEOUSLY.

CAUTION

DO NOT LET THE ENGINE IDLE WITH THE VEHICLE AT STANDSTILL TO WARM UP THE ENGINE AND OBTAIN THE OPERATING TEMPERATURE OF ENGINE OIL. OIL IS BEST CHECKED AFTER A TRIP OR AFTER TRAVELLING APPROXIMATELY 15 km (10 mi), OUT OF TOWN (ENOUGH TO WARM UP ENGINE OIL TO OPERATING TEMPERATURE).

- Shut off the engine.
- Keep the vehicle upright with the two wheels on the ground.
- Check the correct oil level through the appropriate sight glass on the engine crankcase.

MAX = maximum level.

MIN = minimum level

- The oil level is correct when it is close to the "MAX" reference.

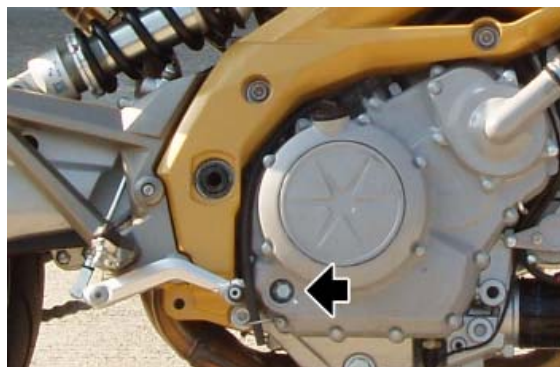

Replacement

Check the engine oil level frequently.

To change the oil:

CAUTION

HOT OIL IS MORE FLUID AND WILL DRAIN OUT MORE EASILY AND COMPLETELY; IDEAL TEMPERATURE IS REACHED AFTER THE ENGINE HAS RUN FOR ABOUT TWENTY MINUTES.



OIL BECOMES VERY HOT WHEN THE ENGINE IS HOT; BE CAREFUL NOT TO GET BURNED WHEN CARRYING OUT THE OPERATIONS DESCRIBED BELOW.

- Use a cloth to wipe off any mud deposit on the area next to the filler plug (1).
- Place a container with + 4000 cm³ (244 cu.in) capacity under the drainage plug (2).
- Unscrew and remove the drainage plug (2).
- Unscrew and remove the filler plug (1).
- Drain the oil into the container; allow several minutes for oil to drain out completely.
- Replace the sealing washer of the drainage plug (2).
- Remove any metal scrap attached to the drainage plug (2) magnet.
- Screw and tighten the drainage plug (2).

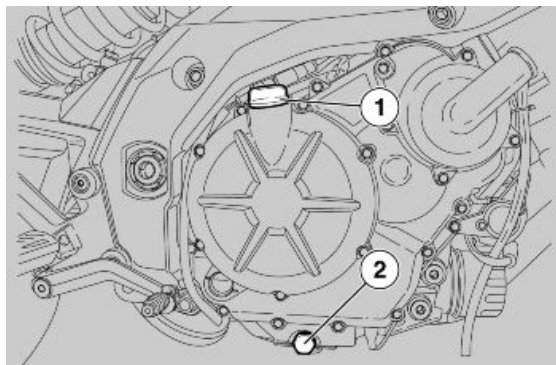

Locking torques (N*m)

Oil drainage plug - M16x1.5 19 Nm (14.01 lbf ft)

- Replace the oil filter.
- Fill up to the right engine oil level by adding recommended engine oil.

See also

[Engine oil filter](#)
[Check](#)

Engine oil filter

- Drain off the engine oil.
- Remove the oil filter.
- Fit a new engine oil filter.
- Add engine oil up to the correct level.

CAUTION

NEVER REUSE AN OLD FILTER.

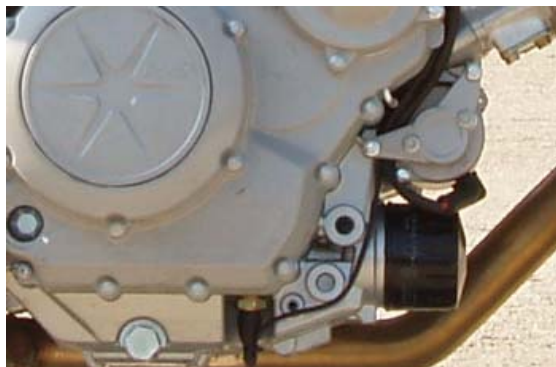

See also

Replacement

Air filter

- Remove the fuel tank.
- Disconnect the air temperature sensor.



- Undo and remove the eight screws.

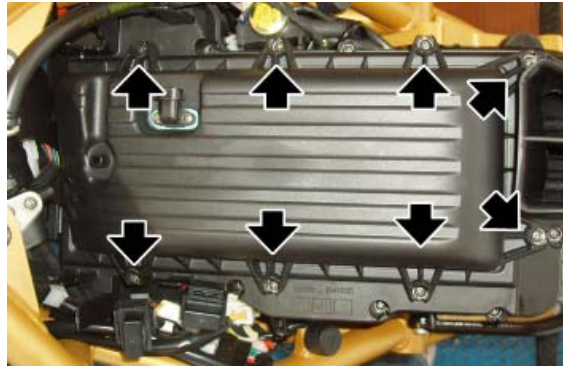

- Remove the clamp and slide off the blow-by tube.



- Remove the filter casing cover.



- Working on both ducts, turn the upper part of the intake ducts anticlockwise and remove it.

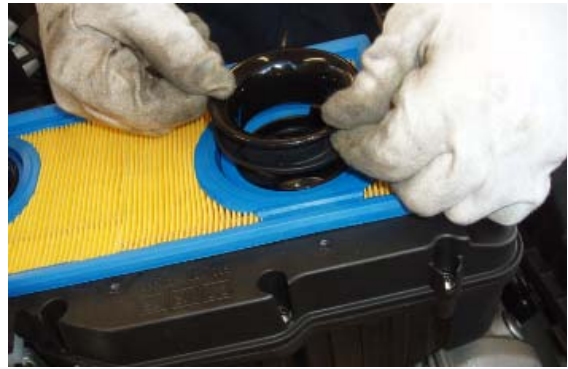

- Remove the filtering element.



COVER THE INTAKE DUCTS WITH A CLEAN CLOTH SO THAT FOREIGN BODIES DO NOT GET INTO THE INLET DUCTS. UPON REFITTING AND BEFORE PLACING THE FILTER CASING COVER, MAKE SURE NEITHER THE CLOTH NOR ANY OTHER OBJECT HAS BEEN LEFT INSIDE THE FILTER CASING. MAKE SURE THE FILTERING ELEMENT IS CORRECTLY PLACED SO THAT UNFILTERED AIR DOES NOT FLOW IN. DO NOT FORGET THAT EARLY WEAR OF THE PISTON RINGS AND THE CYLINDER CAN BE CAUSED BY A MALFUNCTIONING OR MISPLACED FILTERING ELEMENT.



REFITTING

- Upon refitting, pay attention when inserting intake ducts and check that the bayonet joint is released once every duct has been inserted and rotated.

Checking the valve clearance

The following operation can be carried out also with the engine fitted on the vehicle.

- Remove both head covers.

CAUTION

WHENEVER THE HEAD COVER IS REMOVED, ALL FOUR RUBBER RINGS AND THE GASKET SHOULD BE REPLACED.

- Using a thickness gauge, measure the distance between the tip of the crankshaft and the valve bowl.
- Take note of the measurement.

If valve clearance is not within the tolerance range, adjust as follows:

- Take the engine to the TDC.
- Lock the camshafts by using the corresponding timing pins.



Specific tooling

020719Y Timing pin

Characteristic

Valve clearance at intake

0.11 - 0.18 mm (0.0043 - 0.0071 in)

Outlet valve clearance

0.16 - 0.23 mm (0.0063 - 0.0091 in)

- Remove one camshaft at a time
- Leave the other camshaft assembled and blocked by means of the timing pin.

CAUTION

IF BOTH CAMSHAFTS ARE REMOVED, THE ENGINE SPINS MAKING TIMING NECESSARY.

- Remove the bowl tappets and the adjustment shims using a magnet.

NOTE

GREASE THE BOWL TAPPETS AND THE ADJUSTMENT SHIMS PROPERLY EACH TIME THEY ARE REMOVED.



- Replace calibrated pads with a pad thick enough to correct the valve clearance previously detected.
- List of calibrated break pads:

1. Calibrated pad 2.60
2. Calibrated pad 2.65
3. Calibrated pad 2.70
4. Calibrated pad 2.75
5. Calibrated pad 2.80



6. Calibrated pad 2.85
7. Calibrated pad 2.90
8. Calibrated pad 2.95
9. Calibrated pad 3.00
10. Calibrated pad 3.05
11. Calibrated pad 3.10
12. Calibrated pad 3.15
13. Calibrated pad 3.20
14. Calibrated pad 3.25
15. Calibrated pad 3.30
16. Calibrated pad 3.35
17. Calibrated pad 3.40
18. Calibrated pad 2.55
19. Calibrated pad 2.50
20. Calibrated pad 2.45
21. Calibrated pad 2.40

CAUTION**BEFORE REFITTING HEAD COVERS, CLEAN HEAD AND COVER SURFACES CAREFULLY.**

- Apply THREEBOND on the head cover perimeter along the gasket housing.

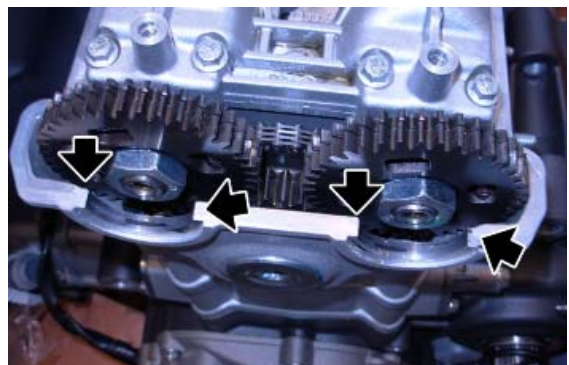

- Apply THREEBOND on the head in the areas indicated in the figure.

**See also**[Removing the head cover](#)

INDEX OF TOPICS

TROUBLESHOOTING

TROUBL

TROUBLESHOOTING PROCEDURE IF THE EFI WARNING LIGHT ON THE INSTRUMENT PANEL TURNS ON OR IF THERE IS ABNORMAL ENGINE PERFORMANCE**CAUTION**

BEFORE CARRYING OUT ANY TROUBLESHOOTING, CAREFULLY READ THE GENERAL CONCEPTS OF ELECTRICAL TROUBLESHOOTING FOUND AT THE BEGINNING OF THE CHECKS AND CONTROLS SECTION IN THE ELECTRICAL SYSTEM CHAPTER.

- 1 - THE "EFI" WARNING LIGHT IS ON AND THE WORD "SERVICE" IS SHOWN or THE "EFI" WARNING LIGHT IS FLASHING AND THE WORDS "URGENT SERVICE" ARE SHOWN or ONE OF THE TWO SITUATIONS TAKES PLACE AND IS SUDDENLY OUT or THERE IS ABNORMAL ENGINE PERFORMANCE
- 2 - CONNECT TO THE CONTROL UNIT THROUGH AXONE (MINIMUM VERSION: 5.1.5) BY SELECTING "SELF- DIAGNOSIS, APRILIA, SL 750 SHIVER"
- 3 - ARE CURRENT "ATT" or STORED "MEM" ERRORS SHOWN IN THE "ERRORS DISPLAY" SCREEN PAGE?

YES, go to 4; NO, go to 12.

- 4 - IF THE ERROR IN THE CENTRAL WINDOW IS SELECTED AND "?" IS DISPLAYED, PRESS THE KEY "?" TO OBTAIN FURTHER INFORMATION ABOUT THE ERROR. THEN GO TO THE "ELECTRICAL SYSTEM/CHECKS AND CONTROLS" CHAPTER AND READ THE INFORMATION CONCERNING THE DEFECTIVE COMPONENT
- 5 - ACCORDING TO WHAT IS INDICATED ABOUT THE ERROR/S, PROCEED AS SUGGESTED AND SOLVE THE PROBLEM
- 6 - WAS THE PROBLEM SOLVED BY REPLACING THE MARELLI CONTROL UNIT?

YES, go to 7; NO, go to 8.

- 7 - READ THE ACTIVATION PROCEDURE FOR A NEW CONTROL UNIT ON THE "ELECTRICAL SYSTEM/CHECKS AND CONTROLS/ECU/MARELLI CONTROL UNIT" CHAPTER - END
- 8 - SELECT "ERROR CLEARING" FROM THE "DEVICES ACTIVATION (INJECTOR)" SCREEN PAGE
- 9 - WAS THE PROBLEM SOLVED BY REPLACING THE THROTTLE GRIP SENSOR (DEMAND) OR THE THROTTLE BODY?

NO, END; YES, go to 10

- 10 - READ THE RESET PROCEDURE ON THE "ELECTRICAL SYSTEM/CHECKS AND CONTROLS/THROTTLE GRIP POSITION SENSOR OR THROTTLE BODY" CHAPTER - END
- 11 - CHECK IF THERE ARE CURRENT OR STORED ERRORS DETECTED BY THE INSTRUMENT PANEL REFERRING TO THE "DIAGNOSIS" CHAPTER, "INSTRUMENT

PANEL ERRORS" SECTION. IF THERE ARE ERRORS PRESENT, SOLVE THE FAILURE AND SELECT "CLEAR ERRORS"; IF THERE ARE NO ERRORS PRESENT, go to 12

- 12 - IN THE "ENGINE PARAMETER READING" SCREEN PAGE, DOES THE "AIR TEMPERATURE" PARAMETER INDICATE A VALUE EQUIVALENT TO ROOM TEMPERATURE?

YES, go to 13; NO, note A

- 13 - IN THE "ENGINE PARAMETER READING" SCREEN PAGE, DOES THE ENGINE TEMPERATURE PARAMETER WITH COLD ENGINE INDICATE A VALUE SIMILAR TO THAT OF THE AIR TEMPERATURE PARAMETER? AFTER STARTING THE ENGINE, DOES THE PARAMETER INCREASE GRADUALLY INDICATING A CORRECT VALUE?

YES, go to 14; NO, note B

- 14 - IN THE "ENGINE PARAMETER READING" AND THE "LAMBDA SENSOR CORRECTION" SCREEN PAGES, WITH ENGINE AT IDLE AND ENGINE TEMPERATURE AT > 90°C, DOES THE VALUE VARY WITHIN THE 0.9 - 1.1 RANGE?

YES, go to 15; NO, note C

- 15 - IN THE "ENGINE PARAMETER READING" SCREEN PAGE AND WITH ENGINE AT IDLE, ARE "FRONT THROTTLE CORRECTION PARAMETERS" OR "REAR THROTTLE CORRECTION" WITHIN THE (-0.4° - +0.4°) RANGE? AND IN THE SAME SCREEN PAGE, ARE THE "FRONT THROT., POT. 1 (DEGREES)" AND "REAR THROT., POT. 1 (DEGREES)" PARAMETERS > OR = TO 0.5° WITH ENGINE AT IDLE? CAUTION: THE DIFFERENCE OF THE THROTTLE CORRECTION VALUES BETWEEN THE REAR AND FRONT CYLINDER MUST NOT BE >0.4°

YES, go to 16; NO, note D

- 16 - CHECK: ENGINE REVOLUTION SENSOR, FUEL PRESSURE, INJECTORS (MECHANICAL OPERATION), COILS (SPARK), ENGINE MECHANICS - END

Note A: SEE THE "ELECTRICAL SYSTEM/CHECKS AND CONTROLS/AIR TEMPERATURE SENSOR" CHAPTER.

Note B: SEE THE "ELECTRICAL SYSTEM/CHECKS AND CONTROLS/ENGINE TEMPERATURE SENSOR" CHAPTER.

Note C: SEE THE "ELECTRICAL SYSTEM/CHECKS AND CONTROLS/LAMBDA PROBE" CHAPTER.

Note D: SEE THE "ELECTRICAL SYSTEM/CHECKS AND CONTROLS/THROTTLE BODY" CHAPTER.

See also

[Checks and inspections](#)

Engine

The engine does not start

THE ENGINE DOES NOT START

CAUTION

AXONE SHOULD BE WORKING PROPERLY AND UPGRADED TO THE 5.1.5 VERSION MINIMUM.

CAUTION

BEFORE ANY TROUBLESHOOTING, MAKE SURE THAT:

- 1) BATTERY VOLTAGE IS ABOVE 12V;
- 2) THE MAIN 30A FUSE IS NOT DAMAGED AND IS ADEQUATELY FITTED;
- 3) AUXILIARY FUSES ARE NOT DAMAGED AND ARE ADEQUATELY FITTED.

NOTE

THE RELAY NUMBER SPECIFIED REFERS TO THE WIRING DIAGRAM. THE POSITION OF THE RELAY ON THE VEHICLE IS INDICATED IN THE "ELECTRICAL SYSTEM/COMPONENT LAYOUT/RELAY LAYOUT" CHAPTER.

- 1 - WITH THE KEY TURNED TO "ON", THE INSTRUMENT PANEL LIGHTS UP BUT NO FAILURE INDICATION IS SHOWN. IS THE FUEL PUMP ACTIVATED?

YES, go to 27; NO, go to 2

- 2 - DOES AXONE COMMUNICATE WITH THE CONTROL UNIT?

YES, go to 3; NO, go to 4

- 3 - ACTIVATE ONE INJECTOR BY MEANS OF AXONE ("DEVICES ACTIVATION" SCREEN PAGE, INJECTOR ICON): IS THE INJECTOR ACTIVATED?

YES, go to 17; NO, go to 12

- 4 - WITH THE KEY TURNED TO "OFF" CHECK IF THERE IS VOLTAGE ON THE ORANGE/RED CABLE OF THE MAIN INJECTION RELAY (POLARISED) 41.

YES, go to 6; NO, go to 5

- 5 - INSPECT IF THERE IS AN INTERRUPTION IN THE ORANGE/RED CABLE FROM THE MAIN INJECTION RELAY (POLARISED) TO THE BATTERY POSITIVE.

- 6 - WITH THE KEY TURNED TO "ON" CHECK IF THERE IS VOLTAGE ON THE GREEN/BLACK CABLE OF THE MAIN INJECTION RELAY (POLARISED) 41.

OK, go to 8; NOT OK, go to 7

- 7 - INSPECT THE GREEN/BLACK CABLE FROM THE MAIN INJECTION RELAY (POLARISED) 41 TO THE KEY SWITCH - END

- 8 - IS THE BLUE CABLE GROUNDED?

YES, go to 10; NO, go to 9

- 9 - RESTORE THE CABLE HARNESS.

- 10 - CHECK IF THERE IS VOLTAGE ON THE RED/BLACK CABLE.

NOT OK, go to 11; OK, go to 12

- 11 - REPLACE THE MAIN INJECTOR RELAY (POLARISED) 41 - END
- 12 - CHECK IF THERE IS VOLTAGE ON THE ORANGE/RED CABLE OF THE AUXILIARY INJECTION RELAY (POLARISED) 42.

YES, go to 13; OK, go to 14

- 13 - CHECK IF THERE IS VOLTAGE ON THE YELLOW/PURPLE CABLE.

OK, go to 15; NOT OK, go to 16

- 14 - RESTORE THE CABLE HARNESS - END
- 15 - SET THE KEY TO "OFF" AND THEN "ON": DOES THE VOLTAGE ON THE YELLOW/PURPLE CABLE REACH APPROX. 1-2V FOR 2 SECONDS?

YES, go to 17; NO, go to 18

- 16 - REPLACE THE AUXILIARY INJECTOR RELAY (POLARISED) 42 - END
- 17 - WHEN THE KEY IS TURNED TO "OFF", CHECK CONTINUITY AND GROUND INSULATION OF THE RED/BROWN CABLE FROM THE AUXILIARY INJECTION RELAY 42 TO THE FUEL PUMP CONNECTOR.

YES, go to 20; NO, go to 19

- 18 - WHEN THE KEY IS TURNED TO "OFF", CHECK CONTINUITY AND GROUND INSULATION OF THE YELLOW/PURPLE CABLE FROM THE RELAY TO PIN 62, VEHICLE CONNECTOR.

YES, go to 22; NO, go to 21

- 19 - RESTORE THE CABLE HARNESS.
- 20 - CHECK THERE IS GROUND INSULATION FOR THE BLUE CABLE OF THE PUMP CONNECTOR.

OK, go to 24; NOT OK, go to 23

- 21 - RESTORE THE CABLE HARNESS - END
- 22 - CHECK THE VEHICLE CONNECTOR.

OK, go to 25; NOT OK, go to 26

- 23 - RESTORE THE CABLE HARNESS - END
- 24 - CHECK IF THE PUMP RESISTANCE IS APPROX. 1 OHM. REPLACE THE PUMP IF THE RESISTANCE VALUE IS NOT THAT SPECIFIED - END
- 25 - REPLACE THE CONTROL UNIT - END
- 26 - RESTORE THE CABLE HARNESS - END
- 27 - DOES THE MOTOR TURN WHEN THE STARTER BUTTON IS PRESSED?

YES, go to 29; NO, go to 28

- 28 - WHAT DOES THE "START-UP ENABLING SWITCH" STATUS ON AXONE (DEVICE STATUS/ICON "0/1" SCREEN PAGE) MEAN?

YES, go to 43; NO, go to 64

- 29 - VOLTAGE TO THE YELLOW/PINK CABLE OF THE RETENTION RELAY (START-UP LOGIC) 39

OK, go to 30; NOT OK, go to 31

- 30 - WITH THE RETENTION RELAY (START-UP LOGIC) 39 DISCONNECTED, KEEP THE STARTER BUTTON PRESSED AND CHECK IF THERE IS APPROX. 1-2V VOLTAGE IN THE YELLOW/RED CABLE

OK, go to 32; NOT OK, go to 33

- 31 - RESTORE THE CABLE HARNESS
- 32 - CHECK THE GROUND CONNECTION OF THE BLUE CABLE OF THE RETENTION RELAY (START-UP LOGIC) 39

OK, go to 34; NOT OK, go to 35

- 33 - RESTORE THE CABLE HARNESS
- 34 - CHECK THAT THE RETENTION RELAY (START-UP LOGIC) 39 WORKS CORRECTLY

OK, go to 36; NOT OK, go to 37

- 35 - RESTORE THE CABLE HARNESS
- 36 - CHECK CONTINUITY OF THE PINK/BLACK CABLE OF THE RETENTION RELAY (START-UP LOGIC) 39 TO PIN 14 VEHICLE CONNECTOR

OK, go to 38; NOT OK, go to 39

- 37 - REPLACE THE RETENTION RELAY (START-UP LOGIC) 39
- 38 - CHECK THE VEHICLE CONNECTOR (PIN 14)

OK, go to 40; NOT OK, go to 41

- 39 - RESTORE THE CABLE HARNESS
- 40 - REFER TO THE CHAPTER ON "ELECTRICAL SYSTEM/ CHECKS AND CONTROLS/ ENGINE REVOLUTION SENSOR"; FOLLOW THE TROUBLESHOOTING STEPS IN THE SECTION REFERRING TO "AXONE: ELECTRICAL ERRORS".

CAUTION: failure NOT identified, go to 42; failure identified, END

- 41 - RESTORE THE CABLE HARNESS
- 42 - CHECK INJECTORS AND ENGINE FOR CORRECT MECHANICAL OPERATION, CHECK FUEL CIRCUIT PRESSURE.
- 43 - WHEN THE STARTER BUTTON IS PRESSED, DOES THE VOLTAGE TO THE YELLOW/PINK CABLE OF THE CONTROL RELAY (START-UP LOGIC) 40 REACH APPROX. ZERO?

YES, go to 44; NO, go to 45

- 44 - CHECK IF THERE IS VOLTAGE IN THE RED/BLACK CABLES ON THE CONTROL RELAY (START-UP LOGIC) 40
YES, go to 50; NO, go to 51
- 45 - CHECK CONTINUITY AND GROUND INSULATION OF THE YELLOW/PINK CABLE FROM THE RELAY TO THE ENGINE CONNECTOR (PIN 2)
OK, go to 47; NOT OK, go to 46
- 46- RESTORE THE CABLE HARNESS - END
- 47 - CHECK THE CONTROL UNIT CONNECTOR
OK, go to 49; NOT OK, go to 48
- 48 - RESTORE THE CABLE HARNESS - END
- 49 - REPLACE THE CONTROL UNIT - END
- 50 - PRESSING THE STARTER BUTTON, DISCONNECT THE CONNECTOR OF THE WHITE/SKY BLUE AND WHITE/RED CABLES OF THE START-UP RELAY 36, AND CHECK IF THERE IS VOLTAGE TO THE YELLOW/RED CABLE OF THE CONTROL RELAY- START-UP LOGIC- 40
OK, go to 52; NOT OK, go to 53
- 51 - REPLACE THE RELAY - END
- 52 - PRESSING THE STARTER BUTTON, CHECK IF THERE IS VOLTAGE TO THE YELLOW/RED CABLE OF THE START-UP RELAY
OK, go to 54; NOT OK, go to 55
- 53 - REPLACE THE RELAY - END
- 54 - CHECK IF THE BLUE CABLE OF THE START-UP RELAY 36 IS GROUNDED
OK, go to 56; NOT OK, go to 57
- 55 - RESTORE THE CABLE HARNESS -END
- 56 - WITH THE KEY TURNED TO "OFF" CHECK IF THERE IS VOLTAGE TO THE REAR RED CABLE (WITH PROTECTION COVER) OF THE START-UP RELAY 36
OK, go to 58; NOT OK, go to 59
- 57 - RESTORE THE CABLE HARNESS -END
- 58 - PRESSING THE STARTER BUTTON, CHECK IF THERE IS VOLTAGE TO THE FRONT RED CABLE OF THE START-UP RELAY 36
OK, go to 60; NOT OK, go to 61
- 59 - RESTORE THE CABLE HARNESS
- 60 - CHECK CONTINUITY OF THE RED CABLE BETWEEN THE START-UP RELAY 36 AND THE STARTER MOTOR
YES, go to 62; NO, go to 63

- 61 - REPLACE THE START-UP RELAY 36 - END
- 62 - REPLACE THE STARTER MOTOR - END
- 63 - RESTORE THE CABLE HARNESS - END
- 64 - WHAT DOES THE "FALL SENSOR" STATUS ON AXONE (DEVICE STATUS/ICON "0/1" SCREEN PAGE) MEAN?

If "NORMAL" is shown, go to 65; If "TIP OVER" is shown, go to 68

- 65 - WITH THE SWITCH SET TO "RUN", WHAT DOES THE "RUN-STOP SWITCH" STATUS ON AXONE ("DEVICE STATUS/ICON "0/1" SCREEN PAGE) MEAN?

If "RUN" is shown, go to 66; If "STOP" is shown, go to 67

- 66 - USING AXONE CHECK THAT THE SIDE STAND, NEUTRAL SENSOR AND CLUTCH SENSOR FUNCTION CORRECTLY; OPERATE ANY DEVICE AND CHECK THE SUITABLE INDICATION ON THE "DEVICE STATUS/ICON "0/1" SCREEN PAGE

If "MALFUNCTION" is shown, go to 71; If "CORRECT OPERATION" is shown, go to 72

- 67 - REFER TO THE CHAPTER ON "ELECTRICAL SYSTEM/CHECKS AND CONTROLS/ FALL SENSOR; INDICATION ON AXONE ALWAYS STOP- END
- 68 - IS THE SENSOR VERTICAL?

YES, go to 69; NO, go to 70

- 69 - REFER TO THE CHAPTER ON "ELECTRICAL SYSTEM/CHECKS AND CONTROLS/ FALL SENSOR; INDICATION ON AXONE ALWAYS TIP OVER - END
 - 70 - SET THE SENSOR TO THE CORRECT POSITION - END
 - 71 - ACCORDING TO THE FAILURE, REFER TO CHAPTER ON "ELECTRICAL SYSTEM/ CHECKS AND CONTROLS/GEAR IN NEUTRAL SENSOR", or "CLUTCH LEVER SENSOR" or "SIDE STAND SENSOR" - END
 - 72 - REPLACE THE CONTROL UNIT - END
-

INDEX OF TOPICS

ELECTRICAL SYSTEM

ELE SYS

Components arrangement

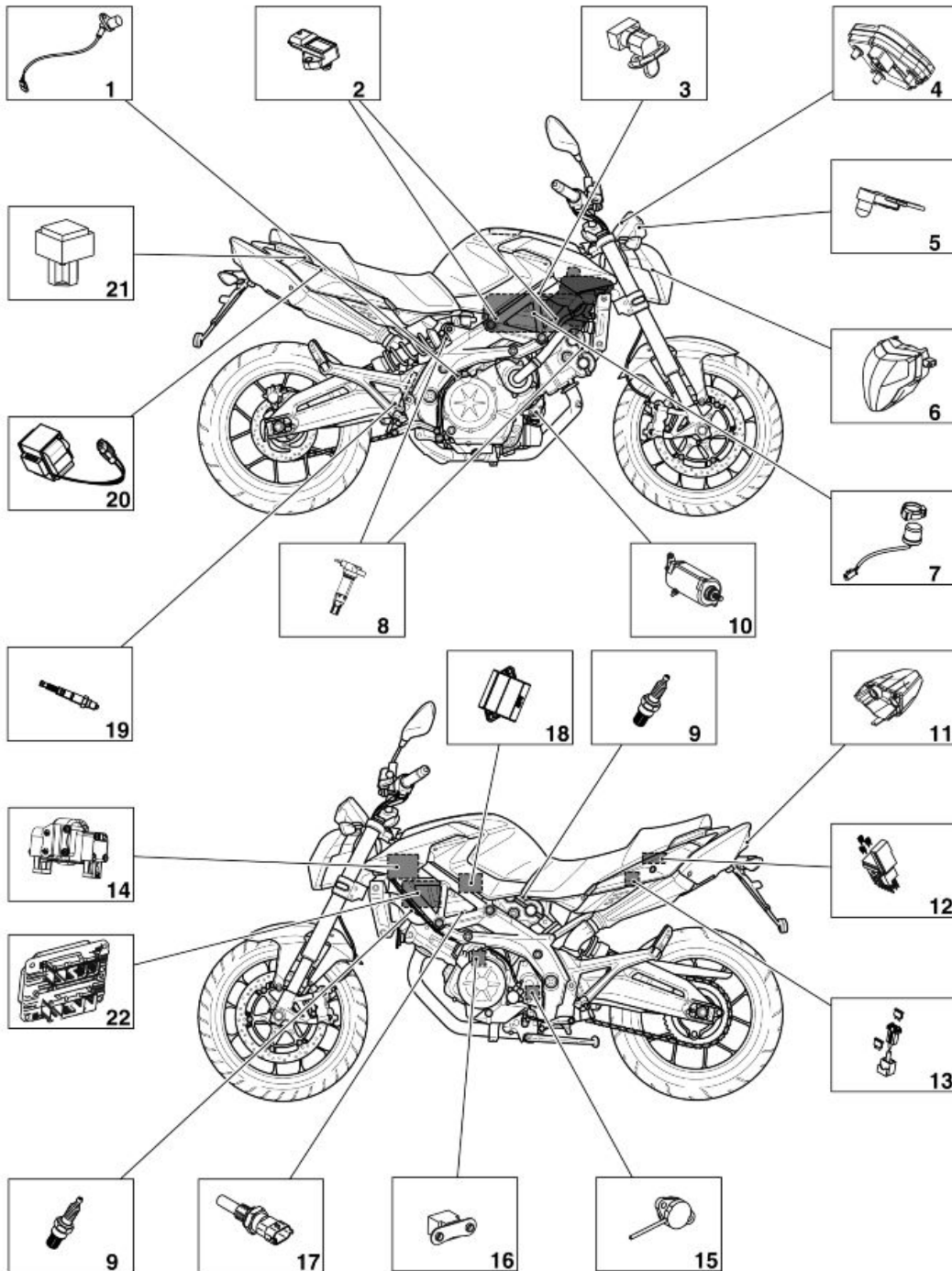

Key

- 1. Revolution sensor
- 2. Intake air pressure sensor
- 3. Intake air temperature sensor

4. Instrument panel
5. Air temperature sensor for instrument panel indication
6. Front headlamp
7. Start-up relay
8. Coils
9. Spark plugs
10. Starter motor
11. Rear light
12. Auxiliary fuses
13. Main fuses
14. Throttle grip position sensor
15. Gear in neutral sensor
16. Revolution sensor - pick up
17. Engine temperature sensor
18. Throttle control unit
19. Lambda probe
20. Fall sensor
21. Main injection relay
22. Engine control unit

CAUTION

A RELAY CANNOT BE IDENTIFIED BASED ONLY ON THE FOLLOWING INDICATIONS: THIS SHOULD BE DONE ALSO IDENTIFYING THE COLOUR OF THE RELAY CABLES.

RELAY LAYOUT ON THE WIRING DIAGRAM AND ON THE VEHICLE**LIGHT LOGIC RELAY**

- Location on the wiring diagram: 9
- Location on the vehicle: under the fuel tank, left side, second relay starting from the front.

START-UP RELAY

- Location on the wiring diagram: 36
- Location on the vehicle: under the fuel tank, right side, fifth relay starting from the front, below in relation to the line of the other relays.

RETENTION RELAY

- Location on the wiring diagram: 39
- Location on the vehicle: under the fuel tank, right side, second relay starting from the front.

CONTROL RELAY

- Location on the wiring diagram: 40
- Location on the vehicle: under the fuel tank, right side, first relay starting from the front.

MAIN INJECTION RELAY

- Location on the wiring diagram: 41
- Location on the vehicle: under the saddle.

AUXILIARY INJECTION RELAY

- Location on the wiring diagram: 42
- Location on the vehicle: under the fuel tank, right side, third relay starting from the front.

FAN CONTROL RELAY

- Location on the wiring diagram: 44
- Location on the vehicle: under the fuel tank, left side, first relay starting from the front.

HIGH-BEAM LIGHTS RELAY

- Location on the wiring diagram: 66
- Location on the vehicle: under the fuel tank, left side, third relay starting from the front.

RECOVERY LOGIC RELAY (URGENT SERVICE)

- Location on the wiring diagram: 67
 - Location on the vehicle: under the fuel tank, right side, fourth relay starting from the front.
-

Electrical system installation

INTRODUCTION

Scope and applicability

The position of the cable harnesses, how they are fixed to the motorcycle and potential problems are defined on the following sections in order to reach the objectives of vehicle reliability.

Materials used and corresponding quantities

The electrical system consists of the following cable harnesses and parts:

- 1 Main Cable Harness
- 1 Filter Casing Cable Harness
- 1 Rear light Cable harness
- 1 Relay-Starter Motor Cable
- 1 Battery - Engine Ground Cable
- 2 Caps for Magura Switches
- 1 Injection Main Relay
- 6 Relays 12 V / 30 A
- 1 Start-up Relay
- Medium black clamps 178 x 4 (7.01 x 0.16 in)
- Small black clamps 98 x 2.5 (3.86 x 0.01 in)
- 1 10-cm (3.94 in) spiral for start-up cable
- 1 Pick-Up divider cable harness (if fitted)

Vehicle sections

The wiring distribution is subdivided in three essential sections, as indicated in the figure.

1. Front section
2. Central section
3. Rear section

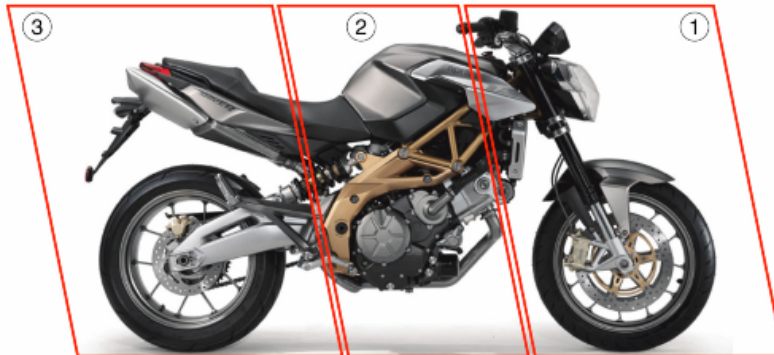

SPECIAL CHECKS FOR THE CORRECT CONNECTION AND LAYING OF CABLES

Carry out the checks described below once the electrical system is refitted, connectors reconnected and clamps and retainers restored.

- Check the connector block for connections and correct tightening in the following connectors.
 1. Instrument panel connector: FRONT SECTION, TABLE J.
 2. Handgrip sensor connectors: CENTRAL SECTION, TABLE F.
 3. Pick Up Connector: CENTRAL SECTION, TABLE Q.
 4. Side Stand Switch Connector.
 5. Regulator Connector: CENTRAL SECTION, TABLE H.
 6. Front cylinder coil and rear cylinder coil connectors: CENTRAL SECTION, TABLE F.
 7. Filter Housing Connectors: CENTRAL SECTION, TABLE F.
 8. ECU and Ground Lead Connectors for the filter casing: CENTRAL SECTION, TABLE A.
 9. Fuel Pump Connector: CENTRAL SECTION, TABLE F.
 10. Key Connector - Right Light Switch Connectors - Left Light Switch Connectors: Connectors inside the housing behind the radiator: FRONT SECTION, TABLE I.
 - THE CONNECTORS LISTED ARE CONSIDERED CRITICAL IN COMPARISON WITH THE OTHERS BECAUSE THE VEHICLE WILL STOP IF THEY ARE ACCIDENTALLY DISCONNECTED.
 - Undoubtedly the connection of the rest of connectors is also important and essential for the correct operation of the vehicle.

Front side

CAUTION

ONCE THE ELECTRICAL SYSTEM IS REFITTED, THE CONNECTORS RECONNECTED AND CLAMPS AND RETAINERS RESTORED, CARRY OUT THE CHECKS INDICATED UNDER "SPECIAL CHECKS FOR THE CORRECT CONNECTION AND LAYING OF CABLES" IN THE "ELECTRICAL SYSTEM INSTALLATION" SECTION.

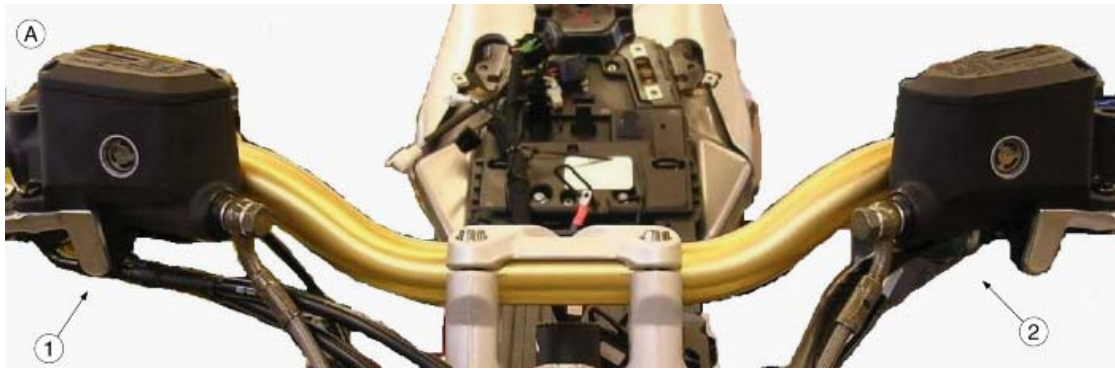
**TABLE A - SWITCHES**

1. Right switch cable harness
2. Left switch cable harness

- Introduce carefully the cap on the cable harnesses (1 and 2) of the switches.

**TABLE B - RIGHT SWITCH CABLE HARNESS
RETAINER**

- Fasten the right switch cable harnesses with a rubber clamp.

**TABLE C - LEFT SWITCH CABLE HARNESS
RETAINER**

- Fasten the left switch cable harnesses with a rubber clamp.



TABLE D - CLUTCH CABLE, THROTTLE CABLE

- With a small clamp, not pulled clamp, fasten the clutch cable to the throttle cable.

**TABLE E - INSTRUMENT PANEL CABLES**

- Fasten the instrument panel cable braid to the chassis with a medium clamp.



TABLE F - INSTRUMENT PANEL CABLES

1. The two medium clamps shall be positioned so that they match the corresponding sections of chassis indicated through two turns of red belt.
2. Place the clamp as close as possible to the chassis vertical tube.

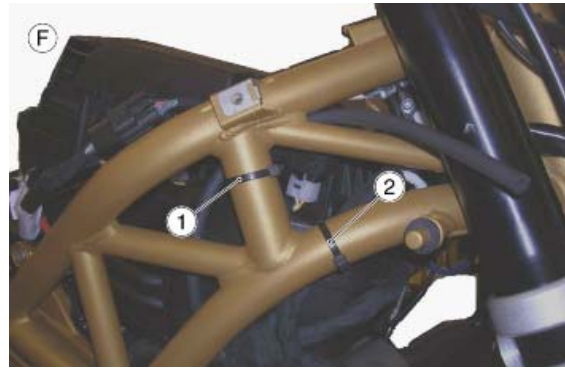
**TABLE G - AIR TEMPERATURE CONNECTOR AND FRONT HEADLAMP CABLE AND FRONT HEADLAMP CABLE**

- Use a small clamp to fasten the air temperature connector and the front headlamp cable to the main cable harness.

**TABLE H - COIL CABLE**

- Fasten the coil cable with a small clamp.

**TABLE I - HOUSING AND CENTRAL CABLE GUIDE**

1. The housing containing light switch and key connectors shall be placed freely over the branch with the clamp and not fixed.
2. Place medium clamps on the central cable guide that holds only the branch that leads to the filter casing left side.

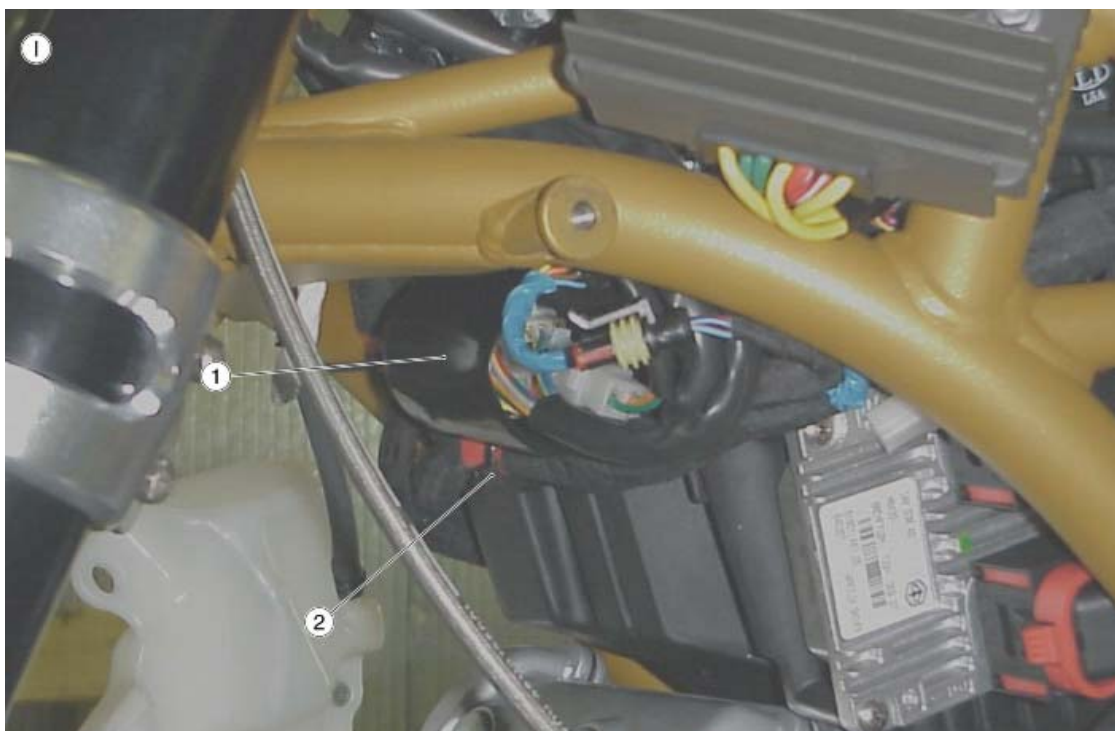
**TABLE J - INSTRUMENT PANEL**

1. Place a small clamp on the left turn indicator connector and the main trunk.
2. The immobilizer aerial connector is fitted between the plate and the instrument panel.
3. Lift the external air temperature sensor upwards once it is connected.

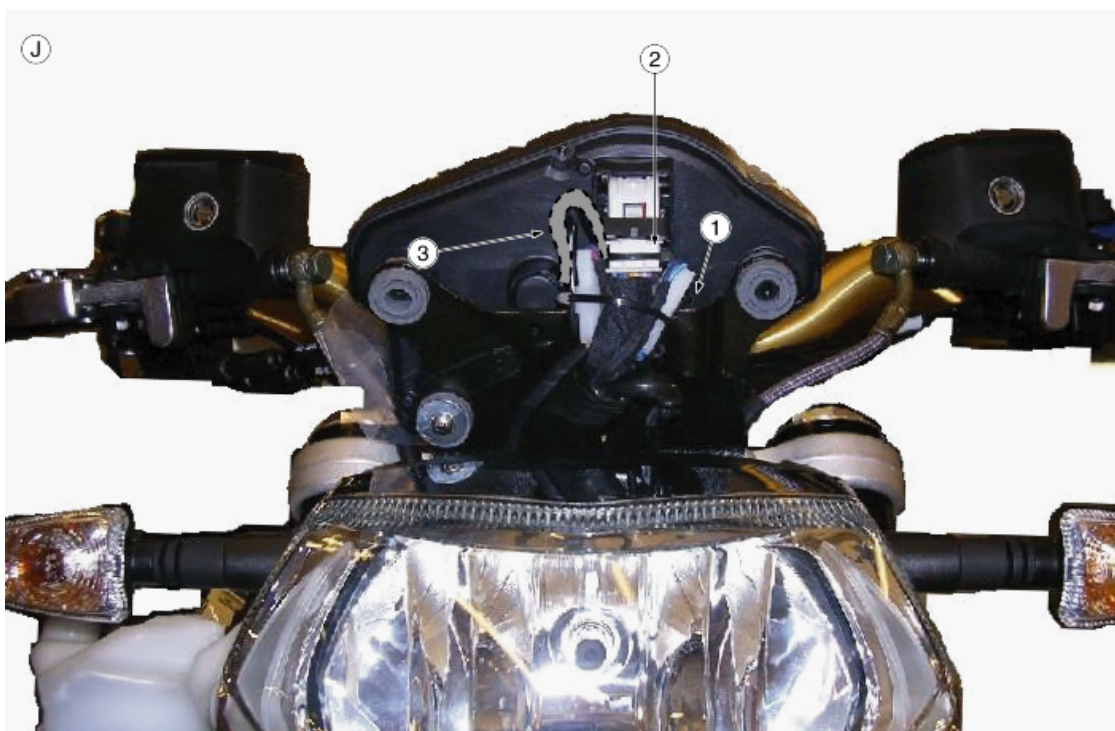
**Parte centrale****CAUTION**

ONCE THE ELECTRICAL SYSTEM IS REFITTED, THE CONNECTORS RECONNECTED AND CLAMPS AND RETAINERS RESTORED, CARRY OUT THE CHECKS INDICATED UNDER "SPECIAL CHECKS FOR THE CORRECT CONNECTION AND LAYING OF CABLES" IN THE "ELECTRICAL SYSTEM INSTALLATION" SECTION.

TABLE A - CONTROL UNIT, MAIN CABLE HARNESS, HORN AND NEUTRAL SENSOR CABLES

1. ECU
2. Engine Connector
3. Vehicle Connector
4. ECU ground connection
5. Horn and neutral sensor cables
6. Main cable harness

The horn and neutral sensor cables shall be laid over the water pipe upon installation.

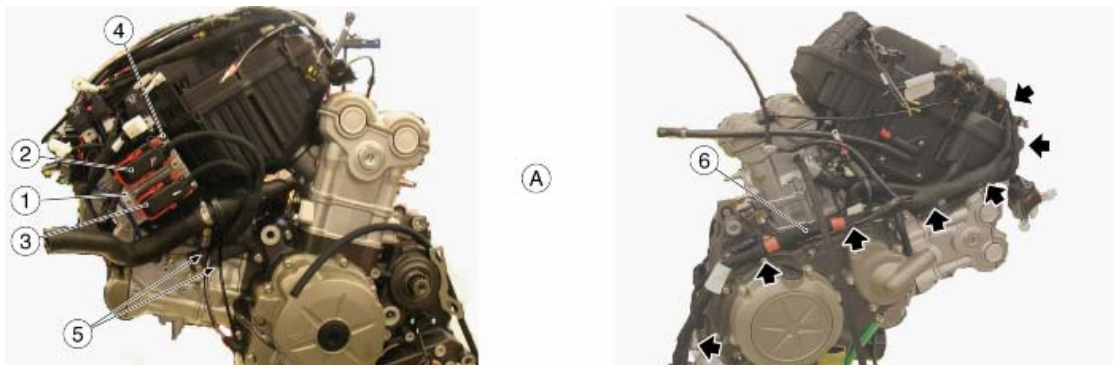

TABLE B - UNDER SEAT CABLE HARNESS

1. Use small clamps to fasten the cables.
2. Use medium clamps to fasten the main cable harness.

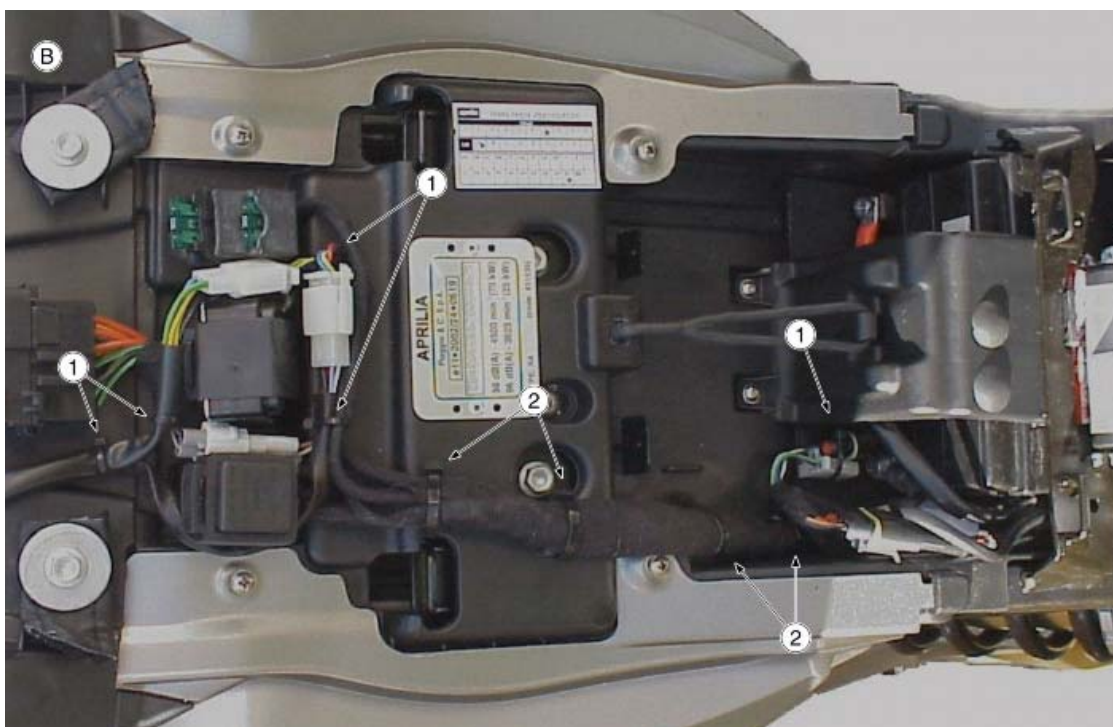
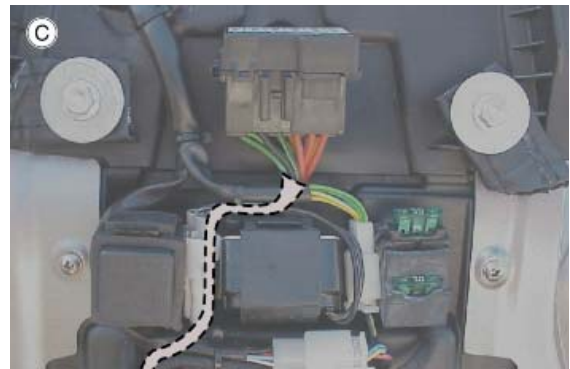

TABLE C - MAIN CABLE HARNESS

- The main cable harness is laid between the relay and the fall sensor, under the fall sensor connector.

**TABLE D - DIAGNOSIS CONNECTORS**

- Fasten both diagnosis connectors with a small clamp, under the cable harness main branch.

**TABLE E - CABLE HARNESSES UNDER THE TANK**

- Fasten the pipe with two medium clamps.
- The flywheel and side stand cables shall be laid through the cable guide screwed to the filter housing.
- Bunch the cables with clamps.
- Fasten with a clamp cables on the filter housing and the rear cylinder coil.



TABLE F - CABLE HARNESSES UNDER THE TANK

1. Place clamps at the connector sides.
2. Mark the connection on the left side using the BLUE belt.
3. Mark the connection on the right side using the WHITE belt.
4. Fasten with a medium clamp.



TABLE G - HANDGRIP SENSOR CONNECTOR

1. Fitting the connector in the handgrip sensor.
2. Closing the connector block.
3. During step (1), move the hook (3) forwards.

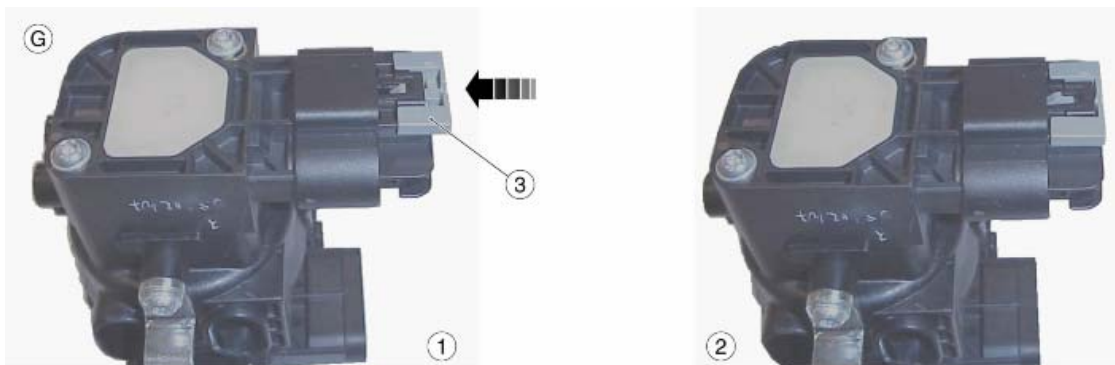

TABLE H - LEFT SIDE CABLE HARNESS UNDER THE TANK

- Identify the regulator output with the WHITE belt.

1. Fasten the cable harness with a clamp.
2. Connector for resistance module.

3. Fasten the cables with a clamp and hold also the control unit upper branch.



TABLE I - PICK-UP AND ENGINE CONTROL UNIT CABLE HARNESSES

1. Cable harness path towards the engine control unit connectors.
2. Pick-up cable harness path.



TABLE J - RIGHT SIDE

1. Use a small clamp to keep the cable fixed to the oil bulb cap.
2. Use a small clamp behind the pipe so that the oil and start-up cable is tightened to the rear pipe.
3. Fasten the cable with medium clamps.

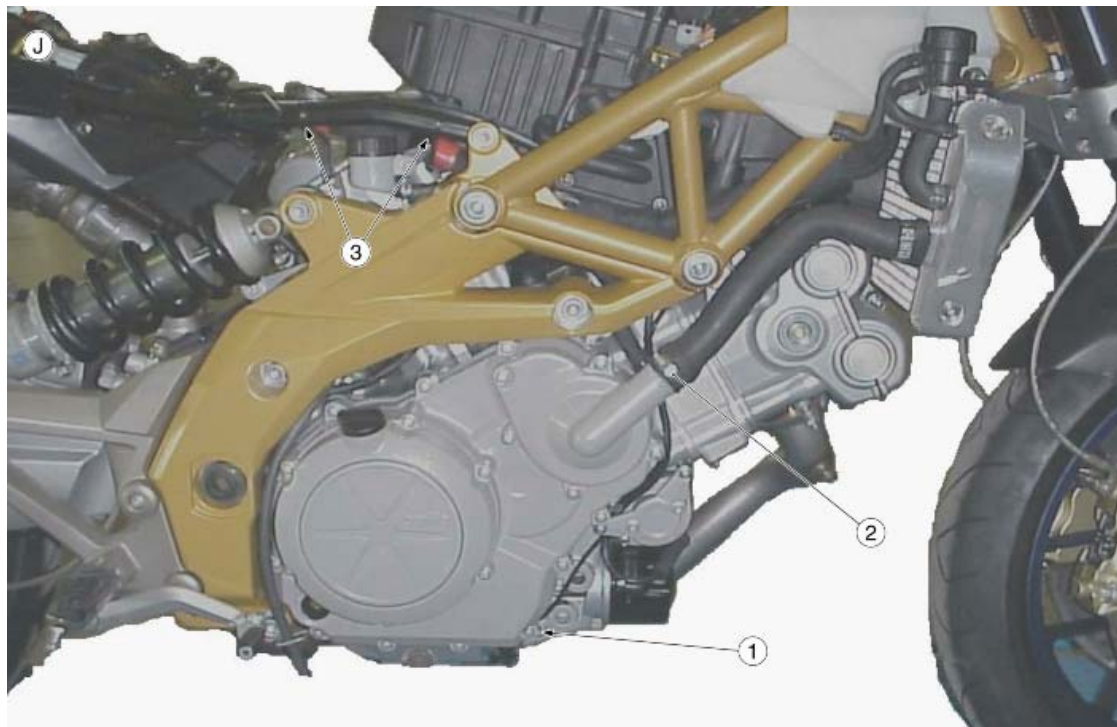

TABLE K - NEUTRAL SENSOR CABLE HARNESS

- Place the neutral sensor cable harness as shown and fasten it with a small clamp where indicated.

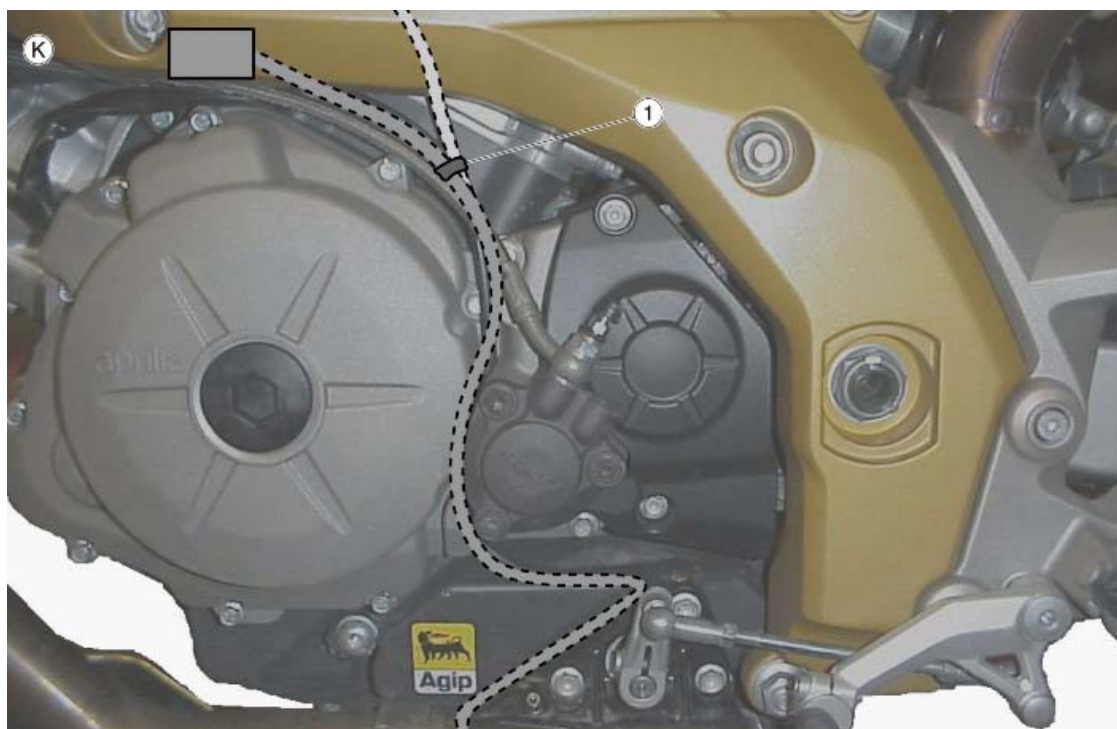
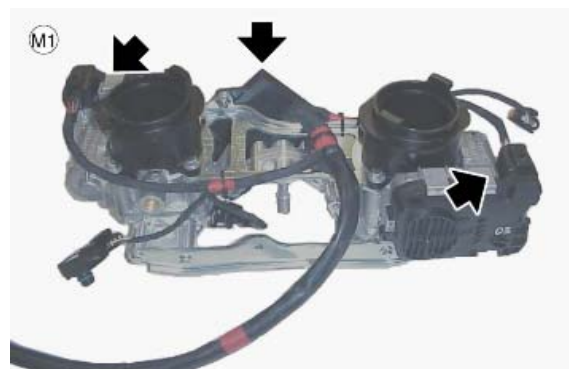

TABLE L - LAMBDA PROBE

- Place two clamps to fasten the cable harness to the chassis, as indicated:
- medium clamp;
 - small clamp.

**TABLE M1 - FILTER CASING CABLE HARNESS**

- Place both throttle valve position sensors.

**TABLE M2 - SENSORS**

- Place the two sensors.

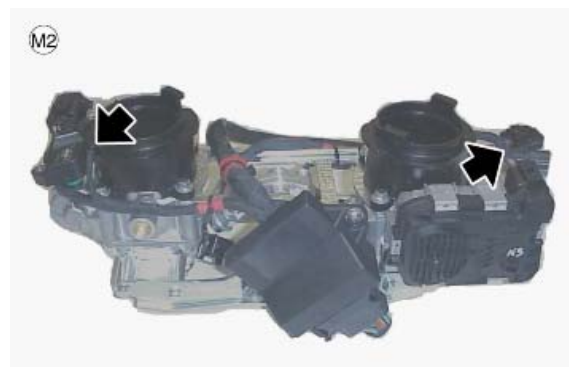
**TABLE M3 - CLAMPS**

- Fasten cable harnesses with clamps.

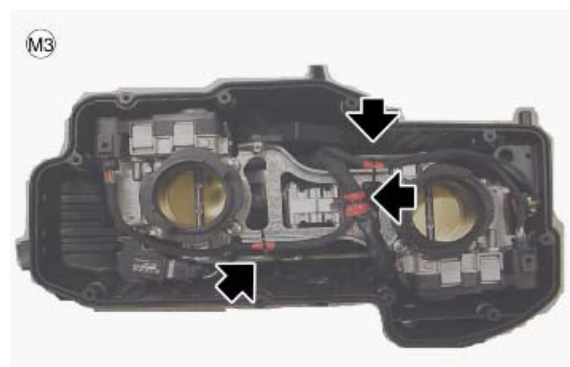

TABLE M4 - FILTER HOUSING

- Insert the throttle body, with the cable harness correctly fixed, in the filter casing.

**TABLE N - GROUND LEAD AND START-UP CABLE**

- Fit the ground lead following the path drawn in figure that will not be visible on the vehicle once fully assembled.
- As indicated above, the ground lead is laid behind the filter casing pipe.
- As regards the lower section, the cable is laid behind the starter motor plate.
- In the central position, insert a small clamp joining the ground lead and the oil cable to the smallest pipe.

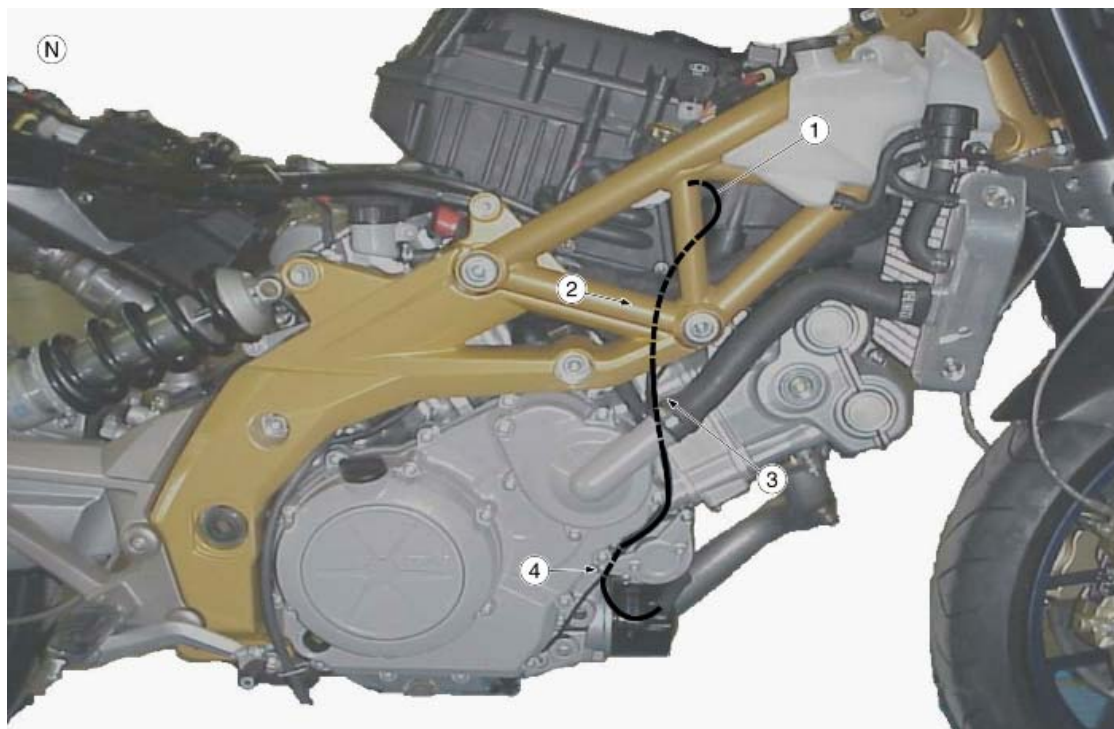
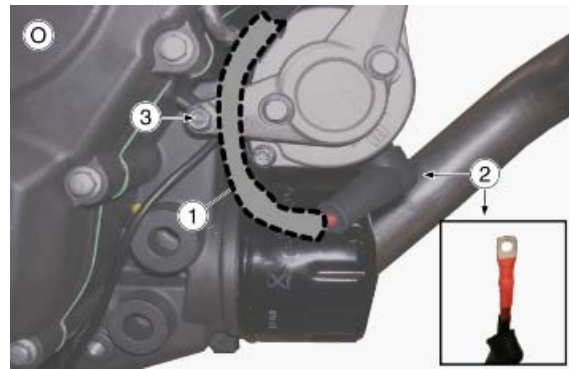
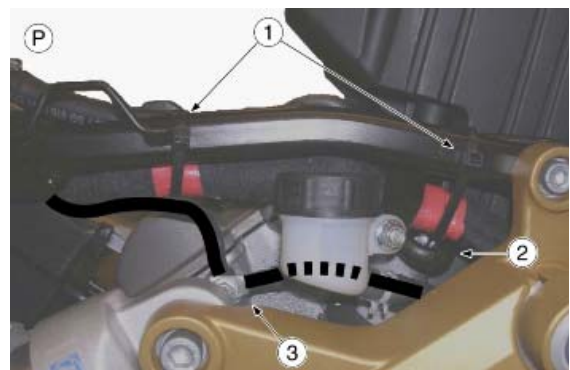

TABLE O - GROUND LEAD AND START-UP CABLE

1. Direct the cable as shown in figure.
2. Before fitting the cable, push the sheath to the panel terminal so as to hide the RED cable (see box).
3. Fasten the cable with a clamp 10-mm (0.39 in) long.

**TABLE P - GROUND LEAD AND START-UP CABLE**

1. Fasten the cable with clamps where indicated.
2. **Be careful not to hold the MAP sensor pipe with the clamp.**
3. Place the cable harness as shown.

**Back side****CAUTION**

ONCE THE ELECTRICAL SYSTEM IS REFITTED, THE CONNECTORS RECONNECTED AND CLAMPS AND RETAINERS RESTORED, CARRY OUT THE CHECKS INDICATED UNDER "SPECIAL CHECKS FOR THE CORRECT CONNECTION AND LAYING OF CABLES" IN THE "ELECTRICAL SYSTEM INSTALLATION" SECTION.

TABLE A - REAR LIGHT CABLE HARNESS

1. Rear right turn indicator: BLACK and RED cables.
2. Left turn indicator: BLACK and SKY BLUE cables.
3. Fasten the rear light cable harness to the rear frame with two small clamps.
4. When fitting the cable harness, make sure that the cable harness sheathing is visible in the indicated area of the curved support.



General wiring diagram

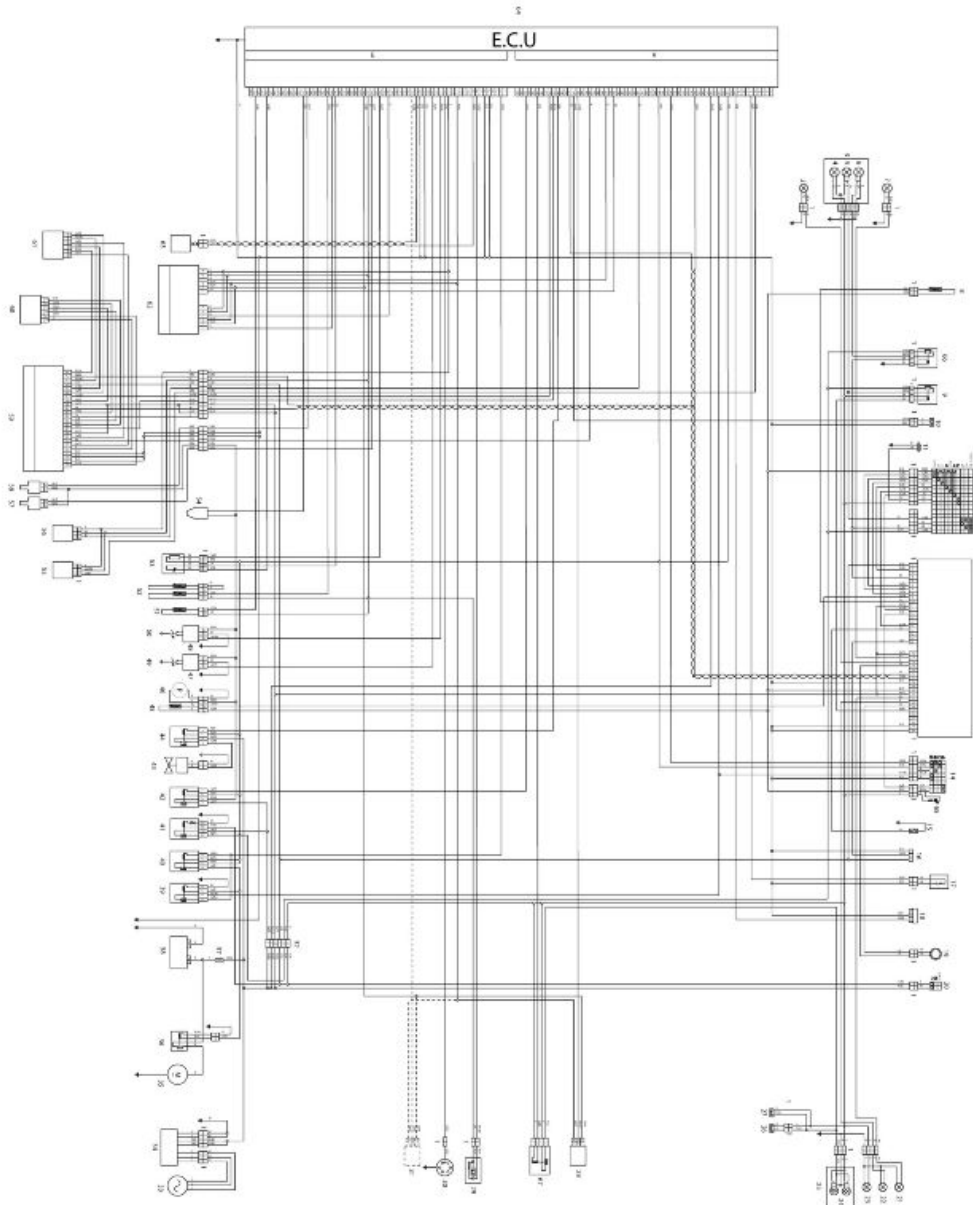

Key:

1. MULTIPLE CONNECTORS
2. RIGHT FRONT TURN INDICATOR
3. COMPLETE FRONT HEADLAMP
4. TAIL LIGHT BULB

5. LOW-BEAM BULB
6. HIGH-BEAM BULB
7. FRONT LEFT TURN INDICATOR
8. AMBIENT AIR TEMPERATURE SENSOR
9. SWITCH LIGHTS LOGIC RELAY
10. CLUTCH
11. HORN
12. LEFT LIGHT SWITCH
13. INSTRUMENT PANEL
14. RIGHT LIGHT SWITCH
15. OIL PRESSURE SENSOR
16. INSTRUMENT PANEL DIAGNOSIS
17. SIDE STAND SWITCH
18. ECU DIAGNOSIS
19. IMMOBILIZER AERIAL
20. KEY SWITCH
21. REAR LEFT TURN INDICATOR
22. REAR RIGHT TURN INDICATOR
23. LICENSE PLATE LIGHT BULB
24. REAR TWIN LIGHT / STOP LIGHT BULB
25. REAR LIGHT ASSEMBLY
26. REAR STOP SWITCH
27. FRONT STOP SWITCH
28. SPEED SENSOR
29. FALL SENSOR
30. NEUTRAL SENSOR
31. TIMING SENSOR (OPTIONAL)
32. AUXILIARY FUSES
33. FLYWHEEL
34. VOLTAGE REGULATOR
35. STARTER MOTOR
36. START-UP RELAY
37. MAIN FUSE
38. BATTERY
39. RETENTION RELAY (START-UP LOGIC)
40. CONTROL RELAY (START-UP LOGIC)
41. MAIN INJECTION RELAY (POLARISED)
42. AUXILIARY INJECTION RELAY (POLARISED)

- 43.FAN
- 44.FAN CONTROL RELAY
- 45.FUEL LEVEL SENSOR
- 46.FUEL PUMP
- 47.REAR CYLINDER COIL
- 48.FRONT CYLINDER COIL
- 49.REAR CYLINDER SPARK PLUG
- 50.FRONT CYLINDER SPARK PLUG
- 51.INTAKE AIR TEMPERATURE SENSOR
- 52.ENGINE TEMPERATURE SENSOR
- 53.LAMBDA PROBE
- 54.PURGE VALVE (OPTIONAL)
- 55.REAR CYLINDER PRESSURE SENSOR
- 56.FRONT CYLINDER PRESSURE SENSOR
- 57.REAR CYLINDER INJECTOR
- 58.FRONT CYLINDER INJECTOR
- 59.EFG 1X THROTTLE CONTROL UNIT (MARELLI)
- 60.REAR CYLINDER THROTTLE
- 61.FRONT CYLINDER THROTTLE
- 62.THROTTLE GRIP POSITION SENSOR
- 63.PICK-UP
- 64.ECU
- 65.HAZARD BUTTON LIGHTING
- 66.HIGH-BEAM LIGHT RELAY
- 67.RECOVERY LOGIC RELAY

Colour key:

Ar Orange

Az Sky blue

B Blue

Bi White

G Yellow

Gr Grey

M Brown

N Black

R Red

Ro Pink

V Green

Vi Purple

Conceptual diagrams

Checks and inspections

GENERAL CONCEPTS OF ELECTRICAL TROUBLESHOOTING

THE CONNECTION DIAGRAMS ARE IN THE ELECTRICAL SYSTEM SECTIONS; PAY ATTENTION TO THESE DIAGRAMS AS THEY SHOW THE CONNECTOR/COMPONENT AS VIEWED FROM THE CABLE HARNESS SIDE, THAT IS LOOKING AT THE CABLES WHEN GOING OUT OF THE "MAIN" CABLE HARNESS AND INTO THE CONNECTOR/COMPONENT.

CAUTION

BEFORE CARRYING OUT ANY TROUBLESHOOTING PROCEDURE ON THE VEHICLE, CHECK THAT THE BATTERY VOLTAGE IS ABOVE 12V.

CONNECTOR CHECK PROCEDURE

The procedure includes the following checks:

1. Observation and check of the connector position on the component or on the coupling connector, making sure that the locking catch is released.
2. Observation of the terminals on the connector: no rust marks or dirt should be present and it is important to check terminal correct positioning on the connector (i.e., all terminals aligned at the same depth) and terminal integrity (i.e., that terminals are not loose, open/bent, etc.). For connectors whose terminals are not visible (e.g. Marelli control unit) use a metal cable of suitable diameter and introduce it carefully in the connector slot at the same depth as for the other terminals of the connector.

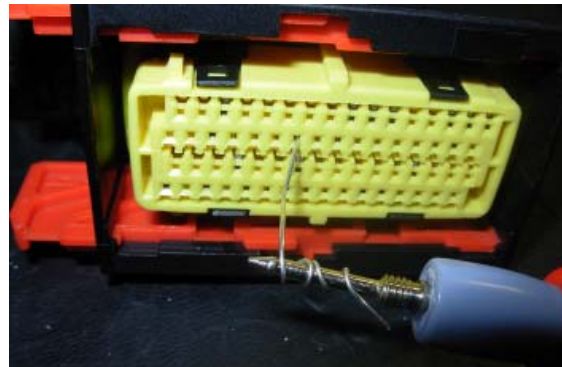

CAUTION

IN CASE OF TEMPORAL MALFUNCTIONING, CARRY OUT ALL DUE CHECKS LOOKING FOR FAILURES BY MOVING SLIGHTLY THE CABLE HARNESS BEING INSPECTED.

3. Pulling the cables slightly from the back of the connector in order to check the correct position of the terminals on the connector and of the cable on the terminal.

CONTINUITY check

Check goal: this control is to check that there are not any circuit interruptions nor excessive resistance, for instance caused by rust, on the two terminals being inspected.

Tester: set the tester on the "continuity" symbol and place the tester probes on the two circuit ends: the tester emits a sound signal only if there is continuity; the tester can also be set to the Ohm symbol to check that the circuit resistance is null or a few tenths of an Ohm.

CAUTION: THE CIRCUIT SHOULD NOT BE ENERGISED, OTHERWISE THE TEST IS IRRELEVANT.

GROUND CONNECTION check

Check goal: this control is to check if a cable or a circuit is in contact with the vehicle ground (-) connection.

Tester: set the tester on the "continuity" symbol and place one tester probe on the vehicle ground connection (or on the battery - terminal) and the other probe on the cable being inspected: the tester sends out a sound signal only if there is continuity. The tester can also be set to the Ohm symbol to check that the circuit resistance is null or a few tenths of an Ohm.

CAUTION! IF THERE IS A GROUND CONNECTION COMING FROM THE CONTROL UNIT, MAKE SURE THAT DURING THE TEST THE CONTROL UNIT IS EARTH CONNECTED TO THE CIRCUIT.

VOLTAGE check

Check goal: this control is to check if a cable is energised, i.e. if it receives power supply from the battery or the control unit.

Tester: set the tester on the direct current symbol and place the tester red probe on the cable being inspected and the black probe on the vehicle ground connection (or on the battery - terminal).

CAUTION

IN CASE OF TEMPORAL MALFUNCTIONING, CARRY OUT ALL DUE CHECKS LOOKING FOR FAILURES BY MOVING SLIGHTLY THE CABLE HARNESS BEING INSPECTED.

Dashboard

In case the EFI warning light turns on and the words SERVICE or URGENT SERVICE are shown on the display, due to an error detected in the injection ECU, the malfunction indication will be deactivated only after the vehicle has been used for a pre-set number of minutes of operation. However, even though the malfunction is no longer present and the control unit considers the error no longer current but memorised (MEM error indication on Axone), the instrument panel may keep showing there is an error present.

Diagnosis

An access code is required to enter this menu which controls the diagnosis function:

- ENTER SERVICE CODE

This is a 5-digit code, fixed for each vehicle. For these vehicles, the code is:

12398

If the code is incorrect, the following message is displayed:

- INCORRECT CODE

and the instrument panel goes back to the main menu. Otherwise, the following menu is displayed:

- EXIT
- ECU DIAGNOSIS
- INSTRUMENT PANEL ERRORS
- ERROR CLEARING
- VEHICLE SERVICING RESET
- UPDATE
- CHANGE KEYS
- KM / MILES

ECU DIAGNOSIS

In this mode a chart is displayed showing potential errors in the control unit.

IT IS NECESSARY REFER TO THE ERROR INDICATIONS GIVEN BY AXONE FOR THIS VEHICLE.

ERRORI ECU	
ACTIVE	
ECU 11	0
ECU 12	0
ECU 13	X
ECU 14	0
ECU 15	0
ECU 16	0

The instrument panel does not keep all previous errors stored in its memory.

INSTRUMENT PANEL ERRORS

In this mode, a chart is displayed showing potential errors in the immobilizer and the sensors connected to it.

ERRORI CRUSCOTTO		
	ACTIVE	MEMO
DSB 01	0	0
DSB 02	0	X
DSB 03	X	X
DSB 04	0	X
DSB 05	0	0
DSB 06	0	X

Instrument panel errors

In this mode, a chart is displayed showing potential errors in the immobilizer and the sensors connected to it.

DSB 01 - Immobilizer failure: key code read but not recognised.

DSB 02 - Immobilizer failure: key code not read (key not present or transponder not working)

DSB 03 - Immobilizer failure: aerial not working (open or short-circuited)

DSB 04 - Internal controller failure

DSB 05 - -

DSB 06 - Ambient air temperature sensor

Error cause

- An oil sensor failure is signalled when it is detected that the sensor circuit is open or shorted to positive.

DSB 07 - Oil pressure sensorError cause

An oil sensor failure is signalled when, with engine off, it is detected that the sensor circuit is open.

Troubleshooting

The test is performed only once when the key is set to ON. This error is signalled by the bulb icon, and the general warning light turns on as well.

DSB 08 - Oil pressure sensorError cause

An oil sensor failure is signalled when, with engine running, it is detected that the sensor circuit is closed. There is an error when the general warning light turns on.

Troubleshooting

This error is signalled by the bulb icon, and the general warning light turns on as well.

The instrument panel must keep all previous errors stored in its memory.

ERROR CLEARING

This option deletes all instrument panel errors; a further confirmation is requested. Use Axone to reset ECU errors.

VEHICLE SERVICING RESET

This function is used to reset vehicle servicing. Using this function, the odometer can be reset only once within the first 200 km (124 mi) of the vehicle, provided this has not been done by the Quality Check.

UPDATE

This function is used to program the instrument panel again. This screen page shows the software version currently loaded; the LCD reads:

- INSTRUMENT PANEL DISCONNECTED. NOW CONNECT THE DIAGNOSIS INSTRUMENT.

The instrument panel will restart to work normally after the key is inserted-extracted.

CHANGE KEYS

With this function the instrument panel can update the keys. Up to 4 keys can be stored.

The user code is first requested to be entered:

- ENTER THE CODE

After entering the correct code, the following message should be shown on the display:

- INSERT THE X KEY
- INSERT THE X+1 KEY

At least one key must be programmed for the next start-ups. If no other key is inserted within 20 seconds or if there is no power or after the fourth key is programmed, the procedure finishes and all the functions of the vehicle and the instrument panel must be enabled (even if only one key has been programmed).

KM / MILES

This menu selects the unit of measurement, either for the speed or the total or partial odometers.

- KM
- MILES

LANGUAGES

Select the user interface language from this menu.

- ITALIANO
 - ENGLISH
 - FRANCAIS
 - DEUTSCH
 - ESPAGNOL
-

Service warning light reset**VEHICLE SERVICING RESET**

This function is used to reset vehicle servicing. Using this function, the odometer can be reset only once within the first 200 km (124 mi) of the vehicle, provided this has not been done by the Quality Check.

In order to activate this function follow the instructions in the DIAGNOSIS section.

See also

[Diagnosis](#)

level indicators**Fuel reserve sensor**

Check proper operation of the sensor by adding a 2W bulb in series to the sensor.

Place a bulb between the battery power supply cable and the connector terminal and connect the negative terminal to the ground connection:

- if the sensor is submerged in petrol (sensor high electrical resistance, approx. 5-7 kOhm), the bulb should remain off.
 - if the sensor is not submerged in petrol, the bulb should turn on.
-

Lights list

Front headlamp

Characteristic

Front tail light

12V - 5W x 2

Low-beam light

12 V - 55 W H7

High-beam light

12 V - 55 W H7

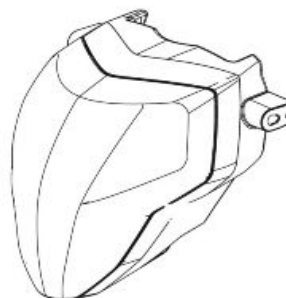

Rear light

Characteristic

Rear tail light / stop light

12V - 5/21W x 2



Fuses

AUXILIARY FUSES

A - Coil, Light logic relay, Recovery logic relay, Stop, Horn, Tail lights, License plate light (10A).

B - Low-beam / high-beam lights (15A).

C - Live positive lead to EFG-1x control unit and to instrument panel, Instrument panel diagnosis (10 A).

D - Instrument panel, Ride by wire (15 A).

E - Permanent positive, ECU power supply (3A).

F - Lambda heater, coils, Start-up logic, Fan and injection relay, Fuel pump, Purge valve, Injectors, ECU, Start-up logic (20 A).

G - Spare fuses (10 - 15 - 20 A)

MAIN FUSES

H - Spare fuses (30 A)

I - Battery recharge, vehicle loads and injection loads (30 A)

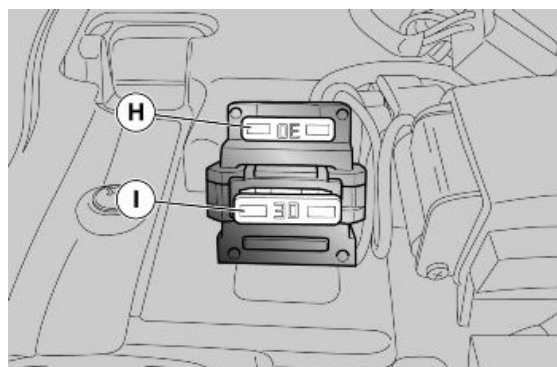
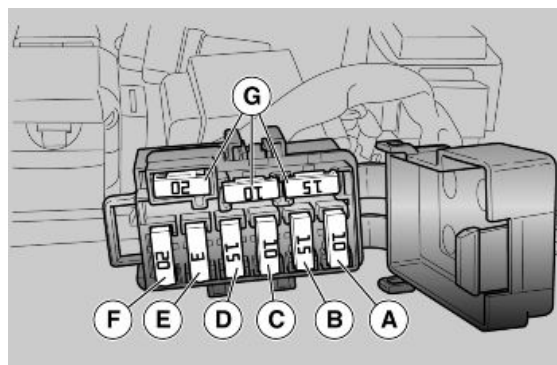

Control unit

MARELLI CONTROL UNIT

Function

It controls the Ride by wire system, the injection/ignition, the system safety checks and the self-diagnosis function.

Location:

- left side, next to the engine

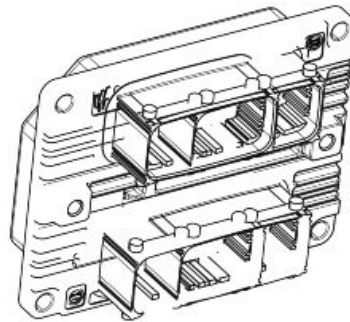

Connector location:

- ENGINE connector: upper connector with control unit on the vehicle; a letter E is stamped on the control unit, to the right of the connector.
- VEHICLE connector: lower connector with control unit on the vehicle; a letter V is stamped on the control unit, to the right of the connector.

Pin-out: see the CONNECTORS section

AXONE: STATUSES

Engine status

Example value: Indefinite_Key ON_Running engine_Stopped_Power latch_Power latch 2_Power latch finished

Engine mode

Example value: Indefinite_Start-up_Stable_Idle_Acceleration_Deceleration_Enters Cut Off_Cut Off_Exits Cut Off

Immobilizer signal

Example value: yes/no

Indicates whether the control unit has received the consent by the instrument panel regarding the immobilizer: coded key or user code entered manually. Potential errors will be shown on the Instrument Panel Errors screen page, on the DIAGNOSIS section of the instrument panel.

Start-up signal

Example value: yes/no

Indicates whether the control unit will enable start-up when requested: in case the safety measures are not respected (side stand, neutral sensor and clutch in correct position) or if the immobilizer does not send the start-up consent to the control unit, the status is NO.

AXONE: FUEL INJECTION SYSTEM

PARAMETERS

Target idle rpm

AXONE: ELECTRICAL ERRORS**EEPROM Error P0601** - circuit not operational.Error cause

- Replace injection ECU. The instrument panel does not indicate the presence of this error even in the ATT status.

RAM Error P0604- circuit not operational.Error cause

- Replace injection ECU. The instrument panel does not indicate the presence of this error even in the ATT status.

ROM Error P0605- circuit not operational.Error cause

- Replace injection ECU. The instrument panel does not indicate the presence of this error even in the ATT status.

A/D converter P0607- circuit not operational.Error cause

- Replace injection ECU.

Level 2 safety reset P0608Error cause

- As the level 2 safety system (comparison between requested torque and calculated torque) has detected a fault, the control unit has reset engine (C gravity).

Troubleshooting

- Continue failure search for the other errors detected .

Safety Engine Stop P0609Error cause

- As the level 3 safety system (control EEPROM) has detected a fault, the control unit has shut off the engine (D gravity).

Troubleshooting

- Replace Marelli control unit.

Reset lines error P0610- circuit not operationalError cause

- Problems on the reset lines (PINS 55 and 56 of the VEHICLE connector) of the throttle motors: lines used to interrupt motor functioning for safety reasons.

Troubleshooting

- Check the VEHICLE connector of the Marelli control unit, the filter housing large connector and the throttle control unit connector: if not OK, restore. If OK, check continuity between the Marelli control unit and the throttle control unit connector from VEHICLE PIN 55 to PIN B7 and from PIN 56 to PIN A7: if not OK, restore. If OK, check that with throttle control unit connector disconnected and with key set to ON, there is no voltage on PINS A7 and B7: if there is voltage, replace the cable harness. If there is no voltage, check that PINS A7 and B7 are insulated from ground connection: if they are not insulated from the ground connection, replace the cable harness. If they are insulated, replace the throttle control unit or the Marelli control unit.

AXONE: NOTES

After installing the control unit and setting the key to ON, wait for 3 seconds, time during which the control unit detects the throttle valve position.

Connect to Axone and check that the status for **Throttle Self-learning is Carried out** and the status for **Throttle grip autodetection is Not carried out**(this last status entails Urgent service being displayed on the instrument panel).

If Throttle Self-learning shows **Not carried out** , go to stage 1. If it shows **Carried out**, go to stage 2.

Stage 1: current errors have probably been detected by the control unit: solve these malfunctions and check the Throttle Self-learning status again. Throttle Self-learning can also be checked from the Parameter adjustment (screwdriver and hammer) screen page.

Stage 2: Carry out the Throttle Self-learning from the Parameter adjustment (screwdriver and hammer) screen page and check that Throttle Self-learning status is Carried out. If it is not correct or the voltage detected on the throttle is out of scale (check with Axone) or if current errors are probably detected by the control unit: solve these malfunctions and repeat the procedure.

Battery

Characteristic

Battery

12V - 10 Ah

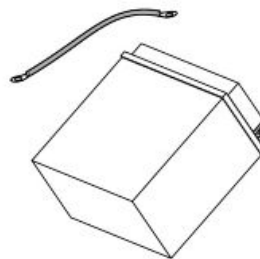

Battery installation

NOTE

THE FIRST TIME THE ENGINE IS STARTED AFTER RECONNECTING THE BATTERY LEADS, WAIT 20 SECONDS BETWEEN THE MOMENT THE KEY IS SET TO "KEY ON" AND THE MOMENT THE STARTER BUTTON CAN BE PUSHED.
THE ENGINE WILL NOT START IF START-UP IS ATTEMPTED BEFORE THE PRE-SET 20 SECONDS.

Speed sensor

VEHICLE SPEED SENSOR

Function

To indicate the vehicle speed by reading the secondary transmission shaft rotation.

Operation / Operating principle

Hall-effect sensor: a square-wave pulse is generated with voltage between 0 and approximately 0.3-0.4V.

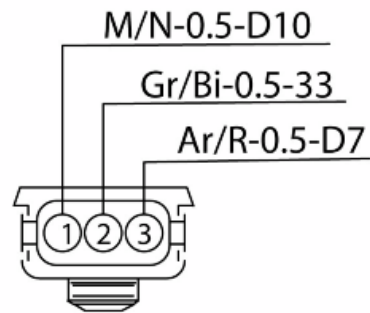

Level in wiring diagram:

Speed sensor

Location:

- on the vehicle: right side, near the clutch cover.
- connector: on the sensor.

Pin-out:

1. Ground connection
2. Output signal
3. Supply voltage 5V

CAUTION

BEFORE CARRYING OUT ANY TROUBLESHOOTING, CAREFULLY READ THE GENERAL CONCEPTS OF ELECTRICAL TROUBLESHOOTING FOUND AT THE BEGINNING OF THE CHECKS AND CONTROLS SECTION IN THE ELECTRICAL SYSTEM CHAPTER.

AXONE: PARAMETERS

Speed sensor

Vehicle speed: km/h

AXONE: LOGIC ERRORS

Sensor/vehicle speed signal P0500 - over maximum limit/ signal not valid.

Error cause

- If over the maximum limit: excessive signal frequency has been detected at PIN 49 VEHICLE. If signal is not valid: a fault in the signal (no signal, short circuit to positive, open or earthed circuit, defective sensor, open circuit, defective measuring cam, etc.) has been de-

ected at VEHICLE PIN 49. This requires a longer recognition time that is counted from zero each time the clutch is operated, the gear is set to neutral or the engine is shut off.

Troubleshooting

- if over the maximum limit: replace the sensor.
- Signal not valid: check the speed sensor connector and the Marelli control unit connector: if not OK, restore. If OK, check that, with key set to ON and the sensor connector disconnected, there is continuity on PIN 1 with the ground connection. If there is no continuity, set the key to OFF and check that there is continuity between ENGINE PIN 36 and PIN 1 of the sensor connector. If there is not, replace the control unit; if there is, check that there is voltage at PIN 3 coming from the control unit (approximately 5V): if there is no voltage, set the key to OFF and check that there is continuity between the ENGINE PIN 13 and PIN 3. If there is continuity, replace the control unit; if there is not, restore the cable harness; if there is 5V voltage, set the key to OFF and check that there is continuity between the VEHICLE PIN 49 and the sensor PIN 2: if there is no continuity, restore the cable harness. If there is continuity, check that the cam that reads the signal is in good conditions: if it is not, replace it. If it is OK, replace the sensor .

SENSOR REMOVAL

- Remove the rear shock absorber.
- Undo and remove the screw.



- Disconnect the speed sensor connector.



- Rotate the speed sensor and slide it off upwards.

NOTE

IT IS STRICTLY FORBIDDEN TO USE THE VEHICLE WITH THE SPEED SENSOR DISCONNECTED.

BESIDES VEHICLE SPEED, THIS SENSOR COMMUNICATES OTHER OPERATION PARAMETERS TO THE CONTROL UNIT.

See also

Removing

Engine rpm sensor

ENGINE REVOLUTION SENSOR**Function**

It informs crankshaft position and speed to the Marelli control unit.

Operation / Operating principle

Inductive sensor: sinusoidal-type generated voltage; two teeth are missing on the flywheel for the reference position.

Level in wiring diagram: revolution sensor

Location:

- on the vehicle: inside the flywheel cover
- connector (if available): near the Marelli control unit

Electrical characteristics:

- Resistance at ambient temperature:
130 +/- 20 Ohm

Pin-out:

1. Negative signal
2. Positive signal

**CAUTION**

BEFORE CARRYING OUT ANY TROUBLESHOOTING, CAREFULLY READ THE GENERAL CONCEPTS OF ELECTRICAL TROUBLESHOOTING FOUND AT THE BEGINNING OF THE CHECKS AND CONTROLS SECTION IN THE ELECTRICAL SYSTEM CHAPTER.

AXONE: PARAMETERS**Engine rpm****AXONE: STATUSES****Synchronised panel**

Example value:Start-up_Lean_Rich_Fault due to rich value_Fault due to lean value

If the probe connector is removed (voltage almost equal to zero), the status is Fault due to lean value

Example value:No_under analysis_standby_Yes

The parameter refers to the engine revs signal: in case the signal has not been correctly identified yet, the under analysis or standby statuses may be displayed.

AXONE: ACTIVATIONS

-

AXONE: ELECTRICAL ERRORS

-

CAUTION

IF THE ELECTRIC CIRCUIT IS INTERRUPTED OR SHORT-CIRCUITED OR NO ERROR IS DISPLAYED, CHECK THE REVOLUTION SENSOR CONNECTOR AND THE MARELLI CONTROL UNIT CONNECTOR: IF NOT OK, RESTORE; IF OK, CHECK THE SENSOR ELECTRIC CHARACTERISTIC IS THE CORRECT ONE: IF IT IS NOT, REPLACE THE SENSOR. IF IT IS THE CORRECT ONE, CHECK THAT THERE IS CONTINUITY ON BOTH CABLES, SUPPLY INSULATION AND GROUND CONNECTION INSULATION. CARRY OUT THE TESTS FROM THE SENSOR CONNECTOR TO THE SENSOR. IF NOT OK, RESTORE THE CABLE HARNESS/REPLACE THE SENSOR. IF OK, PERFORM THE TEST FROM PINS 9 AND 23 OF THE MARELLI CONTROL UNIT ENGINE CONNECTOR.

AXONE: LOGIC ERRORS**Engine revolution sensor P0336** - Synchronism lostError cause

- Displayed if the signal is not as the control unit expects, for example due to voltage fluctuations not correctly repeated.

Troubleshooting

- Check that the flywheel teeth are clean and the sensor is adequately placed in its fitting: if not OK, restore; if OK, replace the sensor.
-

Twistgrip position sensor**THROTTLE GRIP POSITION SENSOR****Function**

The throttle grip is the part to which the throttle control cables arrive; its task is to translate the rider's power request (Demand) into an electrical signal to be sent to the electronic control unit.

Operation / Operating principle

The two throttle cables (opening and closing) actuate on a scroll mounted on a shaft which is sent back to its home position by a return spring. On the shaft covers there are 2 double track potentiometers (4 control tracks) by means of which the torque demand is read (and checked). The 4 potentiometers are tinned and magnetically controlled (contactless); they cannot be overhauled nor replaced

Level in wiring diagram: Throttle grip position sensor.**Location:**

- on the vehicle: under the fuel tank
- connector: direct to the Marelli control unit

Electrical characteristics:

- Not detected by a multimeter as they are contactless: read voltage on the 4 tracks through Axone.

CAUTION

BEFORE CARRYING OUT ANY TROUBLESHOOTING, CAREFULLY READ THE GENERAL CONCEPTS OF ELECTRICAL TROUBLESHOOTING FOUND AT THE BEGINNING OF THE CHECKS AND CONTROLS SECTION IN THE ELECTRICAL SYSTEM CHAPTER.

CAUTION

THE TWO CONNECTORS WHICH GET TO THE THROTTLE GRIP SENSOR ARE ALIKE BUT THEY SHOULD NEVER BE INVERTED. MARK OR CHECK THE CONNECTOR MARKING BEFORE REMOVING THEM (BLUE STAMP + BLUE BAND). THE CONNECTOR AND THE BLUE BAND SHOULD BE PLACED TO THE LEFT. THE CONNECTOR AND THE WHITE BAND SHOULD BE PLACED TO THE RIGHT.

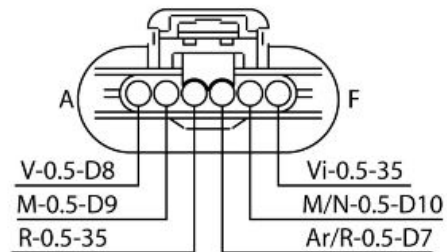
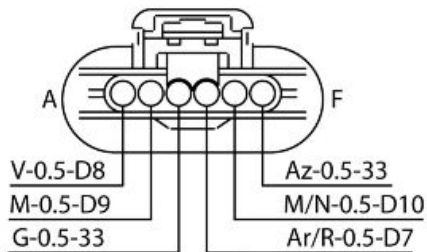
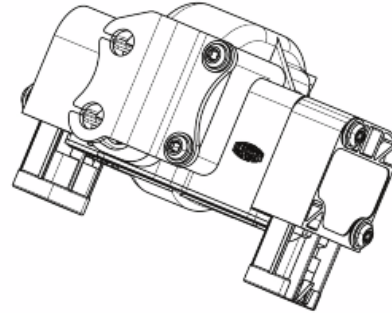

AXONE: PARAMETERS

Left side throttle grip position sensor - track A

Example value: 1107 mV

Voltage value of the left potentiometer track A

Left side throttle grip position sensor - track B

Example value: 1107 mV

Voltage value times 2 of the left potentiometer track B

Right side throttle grip position sensor - track C

3560 mV

Voltage value of the left potentiometer track C

Right side throttle grip position sensor - track D

3555 mV

Voltage value times 2 of the left potentiometer track D

Throttle grip position sensor

1107 mV

Voltage corresponding to the potentiometer track A

Throttle grip opening percentage

0 %

With a released throttle grip, the value read should be 0%, whereas 100 % should be read with throttle grip fully twisted.

AXONE: STATUSES**Throttle grip**

Example value: Slightly twisted_choked_fully twisted

Throttle grip autodetection

Example value: carried out/not carried out

AXONE: PARAMETER ADJUSTMENT**Throttle grip autodetection****AXONE: ELECTRICAL ERRORS**

Left side throttle grip position sensor track A P0150- short circuit to positive / open circuit, short circuit to negative

Error cause

- If shorted to positive: excessive voltage has been detected at PIN 42 of the VEHICLE connector. If the circuit is open, shorted to negative: voltage equal to zero has been detected at PIN 42 of the VEHICLE connector.

Troubleshooting

- if shorted to positive: check the value shown by the parameter of the left Throttle Grip Position Sensor - track A: disconnect the left connector and see the value displayed by Axone: if the voltage does not vary, there is a short circuit in the cable wiring; replace the throttle grip sensor if the voltage drops to zero.
- if the circuit is open, short circuit to negative: check the throttle grip sensor connector and the Marelli control unit connector. If not OK, restore. If OK, check circuit continuity between the two cable terminals. If not OK, restore; if OK, check the cable earth insulation (from the throttle grip sensor connector or the control unit connector): if the cable is not earth insulated, restore the wiring. If it is earth insulated, and with the key set to ON, check that there is power supply for the potentiometer PIN A and that PIN C is connected to earth. If both are correct, replace the throttle grip sensor; if not, check the continuity of the cable that is not functioning properly: if there is continuity, replace the control unit; if not, restore the wiring

Left side Throttle Grip Position sensor - track B P0151- short circuit to positive / open circuit, short circuit to negative

Error cause

- Voltage that is excessive / equal to zero has been detected at PIN 40 of the VEHICLE connector.

Troubleshooting

- short circuit to positive: check the value shown by the parameter of the left Throttle Grip position Sensor track B: disconnect the left connector and see the value displayed by Axone:

if the voltage does not vary, there is a short circuit in the cable wiring; replace the throttle grip sensor if the voltage drops to zero.

- if the circuit is open, short circuit to negative: check the throttle grip sensor connector and the Marelli control unit connector. If not OK, restore. If OK, check circuit continuity between the two cable terminals. If not OK, restore; if OK, check the cable earth insulation (from the throttle grip sensor connector or the control unit connector): if the cable is not earth insulated, restore the wiring. If it is earth insulated, and with the switch key set to ON, check that there is power supply for the potentiometer PIN D and that PIN F is connected to earth. If both are correct, replace the throttle grip sensor; if not, check the continuity of the cable that is not functioning properly: if there is continuity, replace the control unit; if not, restore the wiring.

Right side Throttle Grip Position sensor - track C P0152- short circuit to positive / open circuit, short circuit to negative.

Error cause

- If shorted to positive: excessive voltage has been detected at PIN 30 of the ENGINE connector. If the circuit is open, shorted to negative: voltage equal to zero has been detected at PIN 30 of the ENGINE connector.

Troubleshooting

- if shorted to positive: check the value shown by the parameter of the right Throttle Grip position Sensor - track C: disconnect the right side connector and see the value displayed by the Axone: if the voltage does not vary, there is a short circuit in the cable wiring; replace the throttle grip sensor if the voltage drops to zero.
- if the circuit is open, short circuit to negative: check the throttle grip sensor connector and the Marelli control unit connector. If not OK, restore. If OK, check circuit continuity between the two cable terminals. If not OK, restore; if OK, check the cable earth insulation (from the throttle grip sensor connector or the control unit connector): if the cable is not earth insulated, restore the wiring. If it is earth insulated, and with the key set to ON, check that there is power supply for the potentiometer PIN A and that PIN C is connected to earth. If both are correct, replace the throttle grip sensor; if not, check the continuity of the cable that is not functioning properly: if there is continuity, replace the control unit; if not, restore the wiring

Right side Throttle Grip Position sensor - track D P0153 - short circuit to positive / open circuit, short circuit to negative.

Error cause

- If shorted to positive: excessive voltage has been detected at PIN 44 of the ENGINE connector. If the circuit is open, shorted to negative: voltage equal to zero has been detected at PIN 44 of the ENGINE connector.

Troubleshooting

- if shorted to positive: check the value shown by the parameter of the right Throttle Grip Position Sensor - track D: disconnect the right side connector and see the value displayed by the Axone: if the voltage does not vary, there is a short circuit in the cable wiring; replace the throttle grip sensor if the voltage drops to zero.
- if the circuit is open, short circuit to negative: check the throttle grip sensor connector and the Marelli control unit connector. If not OK, restore. If OK, check circuit continuity between the two cable terminals. If not OK, restore; if OK, check the cable earth insulation (from the throttle grip sensor connector or the control unit connector): if the cable is not earth insulated, restore the wiring. If it is earth insulated, and with the switch key set to ON, check that there is power supply for the potentiometer PIN D and that PIN F is connected to earth. If both are correct, replace the throttle grip sensor; if not, check the continuity of the cable that is not functioning properly: if there is continuity, replace the control unit; if not, restore the wiring.

AXONE: LOGIC ERRORS

Left side Throttle Grip Position (tracks A-B) P0154 - illogical signals.

Error cause

- Two illogical voltage signals have been detected at PINS 42 and 40 of the VEHICLE connector (tracks A-B)

Troubleshooting

- Check the parameters of the left Throttle Grip Position Sensor - tracks A and B: if one of the two values clearly deviates from 600-1400 mV, it means that this potentiometer is defective. Check the throttle grip sensor connector and the control unit connector: if not OK, restore. If OK, check that cable resistance between the throttle grip sensor connector and the control unit is a few tenths of Ohm: if this is not the case, restore wiring. If the value is correct, replace the complete throttle grip sensor.

Right side Throttle Grip Position (tracks C-D) P0155 - illogical signal.

Error cause

- Two illogical voltage signals have been detected at PINS 30 and 44 of the ENGINE connector (tracks A-B)

Troubleshooting

- Check the parameters of the left Throttle Grip Position Sensor - tracks C and D: if one of the two values clearly deviates from 600-1400 mV, it means that this potentiometer is defective. Check the throttle grip sensor connector and the control unit connector: if not OK, restore. If OK, check that cable resistance between the throttle grip sensor connector and the control unit is a few tenths of Ohm: if this is not the case, restore wiring. If the value is correct, replace the complete throttle grip sensor

Throttle Grip position P0156 - illogical signal.

Error cause

- The value of the left side sensor (tracks A-B) does not coincide with the value of the right side sensor (tracks C-D).

Troubleshooting

- Replace the throttle grip sensor

RESET PROCEDURE

If the Marelli control unit or the throttle grip sensor is replaced, check the Throttle grip Autodetection with the diagnosis instrument: once the check is completed, make sure that the throttle grip Autodetection status indicates: carried out.

CAUTION

THE TWO CONNECTORS WHICH GET TO THE THROTTLE GRIP SENSOR ARE ALIKE BUT THEY SHOULD NEVER BE INVERTED. MARK OR CHECK THE CONNECTOR MARKING BEFORE REMOVING THEM (BLUE STAMP + BLUE BAND). THE CONNECTOR AND THE BLUE BAND SHOULD BE PLACED TO THE LEFT. THE CONNECTOR AND THE WHITE BAND SHOULD BE PLACED TO THE RIGHT.

NOTES The two connectors which get to the throttle grip sensor are the same but they should NEVER be inverted. Mark or check the connector marking before removing them (blue stamp+blue band).

REMOVAL

- When required, disconnect the corresponding connectors, undo and remove the two screws and remove the throttle grip position sensor.

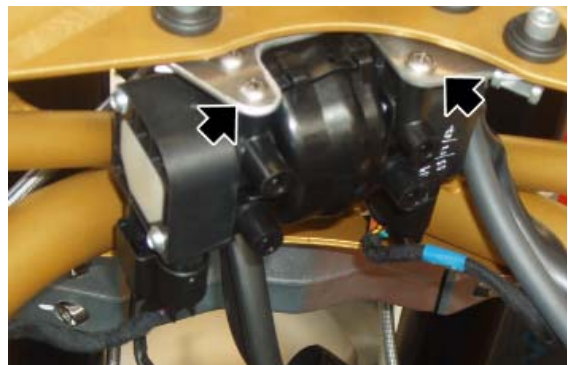

Intake pressure sensor

INTAKE AIR PRESSURE SENSOR

Function

The pressure sensors (one per cylinder) are fundamental not only for the injection configuration at low and stabilised speeds, but also for checking the Ride by wire system: their signal is connected to a TORQUE CHAIN for checking the correct opening of the throttle valves.

Operation / Operating principle

Diaphragm sensor which translates the diaphragm position into electrical voltage when in contact with the intake air.

Level in wiring diagram: intake air temperature sensor

Location:

- on the vehicle: inside the filter casing
- connector: on the sensor

Pin-out:

1. Supply
2. Ground connection
3. Output signal

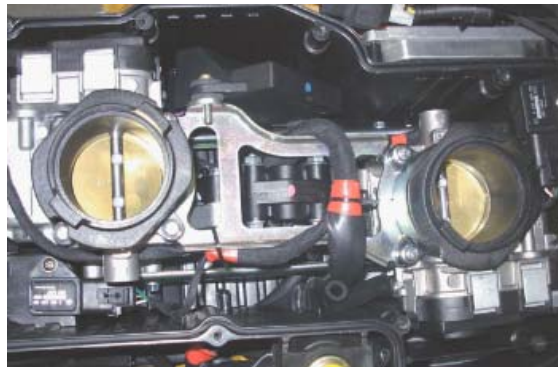
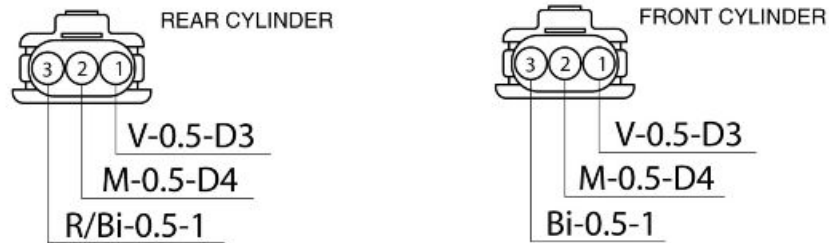

AXONE: PARAMETERS

Front Cylinder Intake Pressure

Example value: 1003 mbar

Pressure read by the front sensor.

Rear Cylinder Intake Pressure

Example value: 1004 mbar

Pressure read by the rear sensor.

Front Cylinder estimated Intake Pressure

Example value: 1003 mbar

Pressure estimated by the control unit according to the throttle position.

Rear Cylinder estimated Intake Pressure

Example value: 1004 mbar

Pressure estimated by the control unit according to the throttle position.

AXONE: ELECTRICAL ERRORS

Front cylinder air pressure sensor P0105 - short circuit to positive / open circuit, short circuit to negative.

Error cause

- If shorted to positive: excessive voltage has been detected at PIN 34 of the VEHICLE connector.

- If the circuit is open, shorted to negative: voltage equal to zero has been detected at PIN 34 of the VEHICLE connector.

Troubleshooting

- If short circuit to positive, see that the parameter of the front Cylinder Intake Pressure on the diagnosis instrument reads approx. 1200 mbar; disconnect the large connector from the filter casing: if the value does not vary, it means that the cable is shorted between the filter casing connector and the control unit connector; restore the cable harness. If the value varies, reconnect the filter casing connector and disconnect the sensor connector: if the value does not vary, it means that the cable is shorted between the filter casing connector and the sensor connector; restore the cable harness. Replace the sensor if the value varies.
- If the circuit is open, short circuit to negative, check filter casing large connector, the Marelli control unit connector and the sensor connector. If not OK, restore. If everything is OK, and with key set to OFF, check if there is continuity between the VEHICLE PIN 34 of the Marelli control unit and the sensor connector PIN 3: if there is no continuity, restore the cable harness. If there is continuity, check the cable earth insulation: if there is continuity to ground, restore the cable harness; if not, with key set to ON check that the voltage on sensor connector PIN 1 is approx. 5 V: if this is not correct, set the key to OFF and check continuity between the ENGINE connector PIN 15 and the sensor connector PIN 1: If not OK, restore the cable harness; if it is OK, replace the control unit. If there is 5V voltage at PIN 1, and with key set to ON, check the continuity to ground of the sensor connector PIN 3: If not OK, restore cable harness; if it is OK, replace the sensor.

Rear cylinder air pressure sensor P0106 -short circuit to positive / open circuit, short circuit to negative.

Error cause

- If shorted to positive: excessive voltage has been detected at PIN 5 of the VEHICLE connector.
- If the circuit is open, shorted to negative: voltage equal to zero has been detected at PIN 5 of the VEHICLE connector.

Troubleshooting

- If short circuit to positive, see that the parameter of the front Cylinder Intake Pressure on the diagnosis instrument reads approx. 1200 mbar; disconnect the large connector from the filter casing: if the value does not vary, it means that the cable is short circuited between the filter casing connector and the control unit connector; restore the cable harness. If the value varies, reconnect the filter casing connector and disconnect the sensor connector: if the value does not vary, it means that the cable is short circuited between the filter casing connector and the sensor connector; restore the cable harness. Replace the sensor if the value varies.

- If the circuit is open, short circuit to negative, check the filter casing large connector, the Marelli control unit connector and the sensor connector; If not OK, restore. If everything is OK, and with key set to OFF, check if there is continuity between the VEHICLE PIN 5 of the Marelli control unit and the sensor connector PIN 3: if there is no continuity, restore the cable harness. If there is continuity, check the cable earth insulation: if there is continuity to ground, restore the cable harness; if not, with key set to ON check that the voltage on sensor connector PIN 1 is approx. 5 V: if this is not correct, set the key to OFF and check continuity between the ENGINE connector PIN 15 and the sensor connector PIN 1: If not OK, restore the cable harness; if it is OK, replace the control unit. if there is 5V voltage at PIN 1, and with key set to ON, check the continuity to ground of the sensor connector PIN 3: If not OK, restore cable harness; if it is OK, replace the sensor.

AXONE: LOGIC ERRORS

front cylinder air pressure sensor P0107 - signal not valid.

Error cause

- According to the engine operation data (rpm, throttle, etc.) an average value for the intake pressure is estimated: if the value read deviates by a given percentage, this error is activated. The most frequent causes can be: abnormal resistance in the sensor circuit (for example, rusted terminals) or sensor with poor performance.

Troubleshooting

- Check the filter casing large connector, the Marelli control unit connector and the sensor connector; if not OK, restore. If everything is OK, check that cable resistance between VEHICLE connector PIN 34 and sensor connector PIN 3 is a few tenths of an Ohm. If it is above that value, restore cable harness. Replace the sensor if it is correct.

rear cylinder air pressure sensor P0108 - signal not valid.

Error cause

- According to the engine operation data (rpm, throttle, etc.) an average value for the intake pressure is estimated: if the value read deviates by a given percentage, this error is activated. The most frequent causes can be: abnormal resistance in the sensor circuit (for example, rusted terminals) or sensor with poor performance.

Troubleshooting

- Check the filter casing large connector, the Marelli control unit connector and the sensor connector; if not OK, restore. If everything is OK, check that resistance between VEHICLE connector PIN 5 and sensor connector PIN 3 is a few tenths of an Ohm. If it is above that value, restore cable harness. Replace the sensor if it is correct.

Error for unexpected intake air in the front cylinder manifold P0210 - signal not valid.

Error cause

- A small difference between the estimated pressure and the measured pressure has been detected: the measured pressure is higher than the estimated one (for example, cut or wrongly connected pipe between sensor and throttle body or a hole in the intake manifold).

Troubleshooting

- Check the pneumatic system between the pressure sensor and the socket to read pressure on the throttle body; check that the intake manifold is in good conditions and the pressure reading hole is clean.

Error for unexpected intake air in the rear cylinder manifold P0211 - signal not valid.

Error cause

- A small difference between the estimated pressure and the measured pressure has been detected: the measured pressure is higher than the estimated one (for example, cut or wrongly connected pipe between sensor and throttle body or a hole in the intake manifold).

Troubleshooting

- Check the pneumatic system between the pressure sensor and the socket to read pressure on the throttle body; check that the intake manifold is in good conditions and the pressure reading hole is clean.

Estimation error for front cylinder intake manifold pressure P0215 - pressure too high/pressure too low.

Error cause

- A substantial difference between the estimated pressure and the measured pressure has been detected (for example, the pipe between sensor and throttle body is fully detached/ clogged or squashed).

Troubleshooting

- Check the pneumatic system between the pressure sensor and the socket to read pressure on the throttle body; check that the intake manifold is in good conditions and the pressure reading hole is clean: there is an evident defect in the intake and pressure reading systems.

Estimation error for rear cylinder intake manifold pressure P0216 - pressure too high/pressure too low.

Error cause

- A substantial difference between the estimated pressure and the measured pressure has been detected (for example, the pipe between sensor and throttle body is fully detached/ clogged or squashed).

Troubleshooting

- Check the pneumatic system between the pressure sensor and the socket to read pressure on the throttle body; check that the intake manifold is in good conditions and the pressure reading hole is clean: there is an evident defect in the intake and pressure reading systems.

Pressure too low at front cylinder manifold error P0217 - signal not valid.

- A small difference between the estimated pressure and the measured pressure has been detected: the measured pressure is below the estimated one (for example, smeared throttle body).

Troubleshooting

- Check the pneumatic system between the pressure sensor and the socket to read pressure on the throttle body; check that the intake manifold is in good conditions and the pressure reading hole is clean.

Pressure too low at rear cylinder manifold error P0218 - signal not valid.

Error cause

- A small difference between the estimated pressure and the measured pressure has been detected: the measured pressure is below the estimated one (for example, smeared throttle body).

Troubleshooting

- Check the pneumatic system between the pressure sensor and the socket to read pressure on the throttle body; check that the intake manifold is in good conditions and the pressure reading hole is clean.

Engine temperature sensor

ENGINE TEMPERATURE SENSOR

Function

it tells the engine temperature to the control unit so as to optimise its operation.

Operation / Operating principle

NTC type sensor (resistance sensor, inversely variable with temperature).

Level in wiring diagram:Temperature sensors

Location:

- on the vehicle: on the front cylinder on the internal side facing the rear cylinder
- connector: on the sensor

Electrical characteristics:

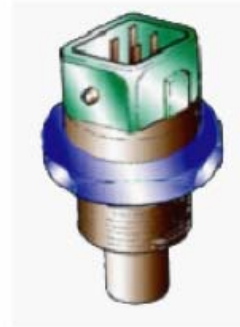

- Resistance at 25°: 2.05 kOhm +/- 100 Ohm
- Resistance at 60°: 575 Ohm +/- 15 Ohm
- Resistance at 90°: 230 Ohm +/- 5 Ohm

**Pin-out:**

1. Yellow brown: 0-5 V signal: PIN B1
2. Brown: PIN B2 ground connection

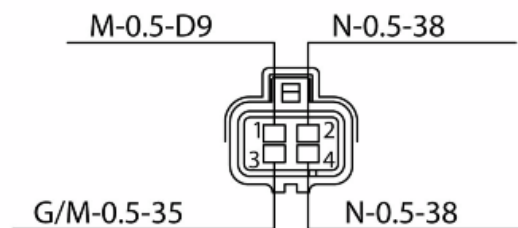
**CAUTION**

BEFORE CARRYING OUT ANY TROUBLESHOOTING, CAREFULLY READ THE GENERAL CONCEPTS OF ELECTRICAL TROUBLESHOOTING FOUND AT THE BEGINNING OF THE CHECKS AND CONTROLS SECTION IN THE ELECTRICAL SYSTEM CHAPTER.

AXONE: PARAMETERS**Engine temperature**

Example value: 75° C

In case of recovery, this value is set by the control unit.

Engine Temp. before Recovery

Example value: -40° C

Value drawn from the signal read without taking into account any recovery: the value in the example refers to an open circuit.

AXONE: ELECTRICAL ERRORS

engine temperature sensor P0115 - open circuit, shorted to positive / shorted to negative.

Error cause

- If the circuit is open, shorted to positive: excessive voltage has been detected at PIN 45 of the ENGINE connector. If shorted to negative: voltage equal to zero has been detected at PIN 45 of the ENGINE connector.
- If the circuit is open, shorted to positive: check the sensor connector and the Marelli control unit connector. If they are OK, check sensor continuity: replace the sensor if not OK; if it is OK, check the continuity between the ENGINE connector PIN 45 and the sensor PIN 1: restore cable harness if there is not continuity; if it is OK, reconnect the control unit connector and, with key set to key ON, check the continuity between the sensor connector PIN 2 and

the vehicle ground connection: if it is correct, it means that the error cause is that the cable is short circuit to positive and it is necessary to restore the cable harness between the ENGINE PIN 45 and the sensor PIN 1; if there is no continuity with the ground connection, check the sensor connector and the Marelli control unit connector. If not OK, restore the cable harness. If OK, check continuity between the ENGINE connector PIN 35 and the sensor connector PIN 2: restore the cable harness if there is no continuity. If there is, it means that the control unit does not supply the ground connection and therefore should be replaced.

Troubleshooting

- If shorted to negative, check sensor correct resistance: if resistance is null, replace the sensor; if resistance is correct, it means that the cable has ground connection: restore the cable harness.

AXONE: LOGIC ERRORS

engine temperature sensor P0116 - signal not valid.

Error cause

- An excessive temperature variation has been detected: for example, the cause may be a contact resistance between the terminals.

Troubleshooting

- Check the sensor connector and the ENGINE connector of the Marelli control unit.

NOTES No error is detected if the sensor does not work correctly or the control unit connector or sensor terminals are rusty: then check through Axone if the temperature indicated is plausible in relation to the engine temperature. Check also that the sensor electrical characteristics are observed: replace the sensor if not OK; if it is OK, check the sensor connector and the Marelli control unit connector

Air temperature sensor

INTAKE AIR TEMPERATURE SENSOR

Function

It tells the control unit the intake air temperature in order to calculate oxygen presence so as to optimise the petrol quantity necessary for correct combustion.

Operation / Operating principle

NTC type sensor (resistance sensor, inversely variable with temperature).

Level in wiring diagram: Temperature sensors

Location:

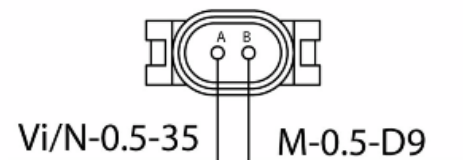

- on the vehicle: on filter casing
- on connector sensor: near the probes

Electrical characteristics:

- Resistance at 0°: 32.5 kΩ +/- 5%
- Resistance at 25°: 10.0 kΩ +/- 5%

Pin-out:

1. 0-5 V signal: PIN 1
2. Ground connection: PIN 2

**CAUTION**

BEFORE CARRYING OUT ANY TROUBLESHOOTING, CAREFULLY READ THE GENERAL CONCEPTS OF ELECTRICAL TROUBLESHOOTING FOUND AT THE BEGINNING OF THE CHECKS AND CONTROLS SECTION IN THE ELECTRICAL SYSTEM CHAPTER.

AXONE: PARAMETERS**Air temperature**

Example value: 26° C

In case of recovery, this value is set by the control unit.

Air Temp. before Recovery

Example value: -40° C

Value drawn from the signal read without taking into account any recovery: the value in the example refers to an open circuit.

AXONE: ELECTRICAL ERRORS

air temperature sensor P0110 - open circuit, shorted to positive / shorted to negative.

Error cause

- If the circuit is open, shorted to positive: excessive voltage has been detected at PIN 63 of the ENGINE connector. If shorted to negative: voltage equal to zero has been detected at PIN 63 of the ENGINE connector.

Troubleshooting

- If the circuit is open, shorted to positive: check the sensor connector and the Marelli control unit connector. If they are OK, check sensor continuity: replace the sensor if not OK; if it is OK, check continuity between the ENGINE connector PIN 63 and the sensor PIN 1: restore cable harness if there is not continuity; if it is OK, reconnect the control unit connector and, with key set to key ON, check the continuity between the sensor connector PIN 2 and the vehicle ground connection: if it is OK, it means that the error cause is that the cable is short circuit to positive and it is necessary to restore the cable harness between the ENGINE PIN 63 and the sensor PIN 1; check the sensor connector and the Marelli control unit connector. If not OK, restore the cable harness. If OK, check continuity between the ENGINE connector PIN 35 and the sensor connector PIN 2: restore the cable harness if there is not continuity.

If there is, it means that the control unit does not supply the ground connection and therefore should be replaced.

- If shorted to negative, check sensor correct resistance: if resistance = 0, replace the sensor; if resistance is correct, it means that the cable has ground connection: restore the cable harness.

NOTES No error is detected if the sensor does not work correctly or the control unit connector or sensor terminals are rusty: then check through Axone if the temperature indicated is plausible in relation to the ambient temperature. Check also that the sensor electrical characteristics are observed: replace the sensor if not OK; if it is OK, check the sensor connector and the Marelli control unit connector.

Lambda sensor

LAMBDA PROBE

Function

It tells the control unit whether combustion is lean or rich.

Operation / Operating principle

The Marelli injection control unit reads and interprets a voltage generated by the difference in oxygen content between the exhaust fumes and the ambient. It does not require an external supply source but, in order to work properly, it should reach a high operating temperature: that is why there is a heating circuit inside.

Level in wiring diagram: Lambda probe

Location:

- on the vehicle: exhaust pipe
- connector: near the probes

Electrical characteristics:

- Oxygen probe with preheating circuit (power 7W)
- It generates voltage within: 0 - 1000 mV
- Heater circuit: continuity (7 - 9 Ohm at ambient temperature)

Pin-out:

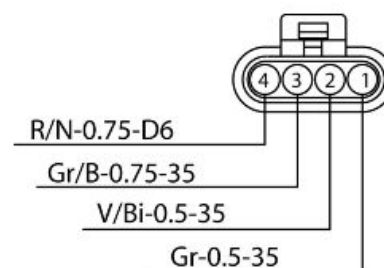
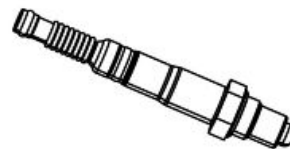

1. Sensor signal + (black wire)
2. Sensor signal - (grey wire)
3. Heater ground connection (white)
4. Heater power supply (white)

THE CONNECTION DIAGRAMS ARE IN THE ELECTRICAL SYSTEM SECTIONS; PAY ATTENTION TO THESE DIAGRAMS AS THEY SHOW THE CONNECTOR/COMPONENT AS VIEWED FROM THE CABLE HARNESS SIDE, THAT IS LOOKING AT THE CABLES WHEN GOING OUT OF THE "MAIN" CABLE HARNESS AND INTO THE CONNECTOR/COMPONENT.

CAUTION

BEFORE CARRYING OUT ANY TROUBLESHOOTING, CAREFULLY READ THE GENERAL CONCEPTS OF ELECTRICAL TROUBLESHOOTING FOUND AT THE BEGINNING OF THE CHECKS AND CONTROLS SECTION IN THE ELECTRICAL SYSTEM CHAPTER.

AXONE: PARAMETERS**Lambda probe**

Example value: 0 - 1000 mV

If there is a short circuit at + 5 V or above, the lambda probe parameter is not equal to the value read by the control unit; a recovery value is displayed instead.

Lambda sensor correction

Example value: 1.00

In closed loop, the value must be close to 1.00 (values not within the 0.90 - 1.10 interval indicate a fault): for example, value 0.75 corresponds to +25% with respect to the reference injection time; 1.25 corresponds to -25%. In an open circuit, the lambda probe signal is too low. Therefore, the control unit takes it as a lean combustion condition and will try to enrich it. The value read will be 0.75: once this correction has been tried, the value shifts to 1.00 fixed and the Lambda probe error is signalled.

AXONE: STATUSES**Lambda**

Example value: Start-up_ Lean_Rich_Fault due to rich value_Fault due to lean value

If the probe connector is removed (voltage almost equal to zero), the status is Fault due to lean value

Lambda check

Example value: Open loop/Closed loop/Rich in closed loop/Lean in closed loop/enriched

Closed loop indicates that the control unit is using the lambda probe signal to keep the combustion as close as possible to the stoichiometric value.

AXONE: ACTIVATIONS**Lambda probe heating**

The auxiliary injection relay (No. 42 in the wiring diagram, placed under fuel tank, right side, third relay starting from the front; CHECK, however, the identification of the relay with the colour of the cables) is energised and the heating circuit is closed to ground 5 times (pin 3 of the lambda probe connector).

The continuity of the wiring is necessary for correct activation: no error indications are displayed in case of lack of activation.

AXONE: ELECTRICAL ERRORS**Lambda probe P0130** - short circuit to positive.Error cause

- Excessive voltage (battery voltage) has been detected at PIN 43 of the ENGINE connector.
Caution: the "lambda probe" parameter is not the real value that is read; a recovery value is displayed instead.

Troubleshooting

- If shorted to positive: with key set to ON, disconnect the sensor connector and measure PIN 1 voltage on the cable harness side (grey cable): if there is voltage (5 or 12 V), restore the cable harness; if there is not, replace the lambda probe.

Lambda probe heating P0135 - short circuit to positive / open circuit, short circuit to negative.Error cause

- If shorted to positive: excessive voltage has been detected at PIN 32 of the ENGINE connector.
- If the circuit is open, short circuit to negative: voltage equal to zero has been detected at PIN 32 of the ENGINE connector.

Troubleshooting

- If shorted to positive: disconnect the probe connector and check the sensor correct resistance: replace the sensor if not OK; if it is OK, restore the cable harness.
- if the circuit is open, short circuit to negative: check the continuity from probe connector (PIN 3 and 4) towards the probe: if not OK, replace the probe; if it is correct, check the sensor connector and the Marelli control unit connector. If not OK, restore. If OK, and with key set to ON and sensor connector disconnected, check if there is battery voltage at PIN 4: if there is not, check the red/black cable between the probe connector and the auxiliary injection relay (No. 42 in the wiring diagram, located under fuel tank, right side, third relay starting from the front; however, the identification of the relay with the colour of the cables). If there are also coil and injector errors, check the relay and its excitation and power line; if there is voltage at PIN 4, check the grey/blue cable earth insulation (PIN 3): if not OK, restore the cable harness. If it is OK, check the continuity of the grey/blue cable (between the sensor connector PIN 3 and the ENGINE PIN 32) and restore the cable harness.

AXONE: LOGIC ERRORS**Lambda probe P0134** - voltage without variation.Error cause

- An abnormal behaviour of the voltage at PIN 43 of the ENGINE connector has been detected: the voltage, that should vary over time, keeps a constant value instead.

Troubleshooting

- Check circuit continuity from probe connector (PIN 1 and PIN 2) toward the probe: replace the lambda probe if there is no continuity; if there is continuity, check the sensor connector and the Marelli control unit connector: If not OK, restore. If OK, check continuity between the ENGINE connector PIN 43 and PIN 60 and restore the cable harness.

CAUTION

IN CASE THE Lambda sensor correction PARAMETER, WITH ENGINE AT IDLE AND H₂O T >90 °C, WHICH IS NOT WITHIN THE 0.9 - 1.1 RANGE, WITHOUT ERRORS, CHECK:

- IF < 0.9, THE PROBE READS LEAN COMBUSTION CONDITIONS AND THE CONTROL UNIT INCREASES INJECTION TIME; CAUSES: CHECK FOR INCORRECT AIR INTAKE, LITTLE PETROL, RUSTY TERMINAL CONTACTS, DEFECTIVE PROBE.

- IF > 1.1, THE PROBE READS RICH COMBUSTION CONDITIONS AND THE CONTROL UNIT REDUCES INJECTION TIME; CAUSES: LITTLE AIR, EXCESSIVE PETROL, DEFECTIVE PROBE.

Injector

INJECTOR

Function

To supply the correct amount of petrol at the right timing.

Operation / Operating principle

Injector coil is excited for the petrol passage to open.

Level in wiring diagram: Coils and injectors.

Location:

- on the vehicle: inside the filter casing
- connector: on injector

Electrical characteristics:

- 14.8 Ohm +/- 5% (at 20 °C (68 °F))

Pin-out:

1. Supply: "+"
2. Ground connection

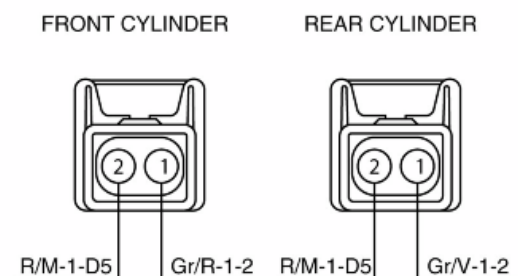
**CAUTION**

BEFORE CARRYING OUT ANY TROUBLESHOOTING, CAREFULLY READ THE GENERAL CONCEPTS OF ELECTRICAL TROUBLESHOOTING FOUND AT THE BEGINNING OF THE CHECKS AND CONTROLS SECTION IN THE ELECTRICAL SYSTEM CHAPTER.

AXONE: PARAMETERS

Front cylinder injection time

Rear cylinder injection time

AXONE: ACTIVATIONS

Front injector

The auxiliary injection relay (No. 42 in the wiring diagram, placed under fuel tank, right side, third relay starting from the front; CHECK, however, the identification of the relay with the colour of the cables) is

energised for 5 seconds and the grey/green cable of the injector is closed to ground for 4 ms per second. Disconnect the 4-way connector of the fuel pump to be able to hear the relay and injector activation. The continuity of the wiring is necessary for correct activation: no error indications are displayed in case of lack of activation.

Rear injector

The auxiliary injection relay (No. 42 in the wiring diagram, placed under fuel tank, right side, third relay starting from the front; CHECK, however, the identification of the relay with the colour of the cables) is energised for 5 seconds and the grey/red cable of the injector is closed to ground for 4 ms per second. Disconnect the 4-way connector of the fuel pump to be able to hear the relay and injector activation. The continuity of the wiring is necessary for correct activation: no error indications are displayed in case of lack of activation.

AXONE: ELECTRICAL ERRORS

Front cylinder injector P0201 - short circuit to positive / short circuit to negative / open circuit.

Error cause

- If shorted to positive: excessive voltage has been detected at PIN 50 of the ENGINE connector.
- If shorted to negative: no voltage has been detected.
- If the circuit is open: an interruption has been detected.

Troubleshooting

- if shorted to positive: disconnect the injector connector, set key to ON, activate the component with Axone and check the voltage on the filter casing grey/green cable on the filter casing small connector towards the Marelli control unit: if there is voltage, restore the cable harness between the filter casing connector and the Marelli control unit. If there is no voltage, reconnect the connector and check if there is voltage at PIN -: if there is voltage, restore the filter casing cable harness. If there is not, replace the sensor.
- if shorted to negative: disconnect the injector connector, set the key to ON and check if there is a ground connection on the grey/green cable: if there is, restore the cable harness between the filter casing connector and the Marelli control unit; if there is not, reconnect the connector and disconnect the injector connector and check if there is a ground connection on PIN -: if there is voltage, restore the filter casing cable harness. If there is not, replace the injector.
- the circuit is open: check the component correct electrical characteristic: if it is not correct, replace the component; if it is correct, check the filter casing small connector, the connector on the component and the Marelli control unit connector: If not OK, restore; if OK, check cable continuity between ENGINE PIN 50 and component PIN - and restore the cable harness.

Front cylinder injector P0202 - See front injector

Error cause

- If shorted to positive: excessive voltage has been detected at PIN 34 of the ENGINE connector.
- If shorted to negative: no voltage has been detected.
- If the circuit is open: an interruption has been detected.

Troubleshooting

- if shorted to positive: disconnect the injector connector, set key to ON, activate the component with Axone and check the voltage on the filter casing grey/green cable on the filter casing small connector towards the Marelli control unit: if there is voltage, restore the cable harness between the filter casing connector and the Marelli control unit. If there is no voltage, reconnect the connector and check if there is voltage at PIN -: if there is voltage, restore the filter casing cable harness. If there is not, replace the sensor.
- if shorted to negative: disconnect the injector connector, set the key to key ON and check if there is a ground connection on the grey/red cable: if there is, restore the cable harness between the filter casing connector and the Marelli control unit; if there is not, reconnect the connector and disconnect the injector connector and check if there is a ground connection on PIN -: if there is voltage, restore the filter casing cable harness. If there is not, replace the injector.
- the circuit is open: check the component correct electrical characteristic: if it is not correct, replace the component; if it is correct, check the filter casing small connector, the connector on the component and the Marelli control unit connector: If not OK, restore. If OK, check cable continuity between the ENGINE PIN 34 and component PIN - and restore the cable harness.

Coil

COIL

Function

Spark generation.

Operation / Operating principle

Inductive discharge system.

Level in wiring diagram: coils and injectors.

Location:

- on the vehicle: on the cylinder head
- connector (if available): -

Electrical characteristics:

- Primary circuit resistance: approx. 1 Ohm at 20°C between PIN 1 and 3.

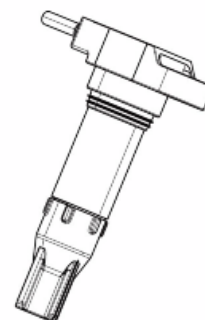

- Secondary circuit resistance: MOhm value range (with positive probe on coil).

Pin-out:

1. Supply + batt V
2. Secondary circuit ground connection
3. Activation from control unit

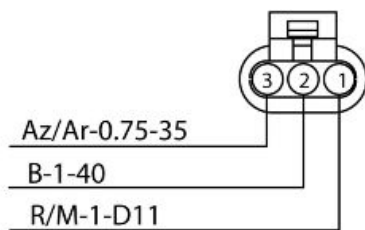
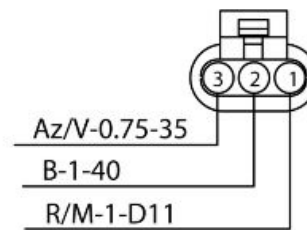
FRONT CYLINDER**REAR CYLINDER****CAUTION**

BEFORE CARRYING OUT ANY TROUBLESHOOTING, CAREFULLY READ THE GENERAL CONCEPTS OF ELECTRICAL TROUBLESHOOTING FOUND AT THE BEGINNING OF THE CHECKS AND CONTROLS SECTION IN THE ELECTRICAL SYSTEM CHAPTER.

AXONE: PARAMETERS

Rear coil ignition advance

Front coil ignition advance

AXONE: STATUSES

-

AXONE: ACTIVATIONS**Front coil**

The auxiliary injection relay (No. 42 in the wiring diagram, placed under fuel tank, right side, third relay starting from the front; CHECK, however, the identification of the relay with the colour of the cables) is energised for 5 seconds and the sky blue/orange cable of the coil is closed to ground for 2 ms per second. Disconnect the 4-way connector of the fuel pump to be able to hear the relay and injector activation. The continuity of the wiring is necessary for correct activation: no error indications are displayed in case of lack of activation.

Rear coil

The auxiliary injection relay (No. 42 in the wiring diagram, placed under fuel tank, right side, third relay starting from the front; CHECK, however, the identification of the relay with the colour of the cables) is energised for 5 seconds and the sky blue/green cable of the coil is closed to ground for 2 ms per second. Disconnect the 4-way connector of the fuel pump to be able to hear the relay and injector activation. The continuity of the wiring is necessary for correct activation: no error indications are displayed in case of lack of activation.

AXONE: ELECTRICAL ERRORS**Lambda probe P0130** - short circuit to positive / circuit, short circuit to negativeError cause

- If shorted to positive: excessive voltage has been detected at PIN 17 of the ENGINE connector. If the circuit is open, shorted to negative: voltage equal to zero has been detected at PIN 17 of the ENGINE connector.

Troubleshooting

- if shorted to positive: disconnect the coil connector, set the key to ON, activate the coil with Axone and check voltage at connector PIN 3: if there is voltage, restore the cable harness; if voltage = 0, replace the coil. Open circuit, short circuit to negative: check the coil connector and the Marelli control unit connector. If not OK, restore; if everything is OK, check cable continuity between the two cable terminals. If there is no continuity, restore the cable harness; if there is cable continuity, with key set to ON, check the cable earth insulation (from coil connector or control unit connector). If not OK, restore the cable harness.

Rear coil P0352- short circuit to positive / open circuit, short circuit to negative.Error cause

- If shorted to positive: excessive voltage has been detected at PIN 19 of the ENGINE connector.
- If the circuit is open, shorted to negative: voltage equal to zero has been detected at PIN 19 of the ENGINE connector.

Troubleshooting

- If shorted to positive: disconnect the coil connector, set the key to ON, activate the coil with Axone and check voltage at connector PIN 3: if there is voltage, restore the cable harness; if voltage = 0, replace the coil.
- If the circuit is open, short circuit to negative: check the coil connector and the Marelli control unit connector. If not OK, restore; if everything is OK, check cable continuity between the two cable terminals. If there is no continuity, restore the cable harness; if there is cable continuity, with key set to ON, check the cable earth insulation (from coil connector or control unit connector). If not OK, restore the cable harness.

AXONE: LOGIC ERRORS

-

Throttle body

THROTTLE BODY

Function

To inform the throttle control unit the position of the two throttle valves and to drive them both.

Operation / Operating principle

All the unit internal components (potentiometer and electric motor) are contactless; therefore, no electrical diagnosis is possible for the throttle body, only for the circuits connected to it.



Throttle body activation takes place every time the key is set to ON: correct activation is indicated when the stop lights turn on.

If during activation, the engine is started, the activation is not completed and the stop lights do not turn on.

Every 150 key-ONs, however, the throttle valves are forced to activation. If start-up is attempted during this activation (which requires 3 seconds), the engine will not start.

Level in wiring diagram:

throttle control unit.

Location:

- on the vehicle: inside the filter casing
- connector: on the throttle body

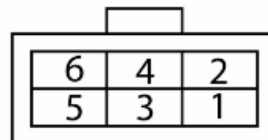

Pin-out:

1. potentiometer signal: 1
2. supply voltage + 5V
3. throttle valve control (+)
4. potentiometer signal: 2
5. throttle valve control (+)
6. ground connection

CAUTION

BEFORE CARRYING OUT ANY TROUBLESHOOTING, CAREFULLY READ THE GENERAL CONCEPTS OF ELECTRICAL TROUBLESHOOTING FOUND AT THE BEGINNING OF THE CHECKS AND CONTROLS SECTION IN THE ELECTRICAL SYSTEM CHAPTER.

AXONE: PARAMETERS

Front throttle Potentiometer 1 (voltage)

Example value: 800 mV

The value in the example refers to engine conditions with key set to ON.

Front throttle Potentiometer 2 (voltage)

Example value: 3878 mV

The value in the example refers to engine conditions with key set to ON.

Rear throttle Potentiometer 1 (voltage)

Example value: 780 mV

The value in the example refers to engine conditions with key set to ON.

Rear throttle Potentiometer 2 (voltage)

Example value: 3756 mV

The value in the example refers to engine conditions with key set to ON.

Front throttle Potentiometer 1 - 2 (degrees) / Rear throttle Potentiometer 1 - 2 (degrees)

Example value: 6.5°

With key set to ON, the throttle is kept in position by the springs (approximately 5 - 7°). After the engine starts up at idle, the throttle is kept close to the mechanical minimum (above or equal to 0.5°). When the gear is not engaged, at approx. 6000 rpm, throttles open very little because the requested torque is too low (approximately 5 - 7°).

Front / rear cylinder throttle correction

Example value: 0.0°

For example, if there is a hole in the intake manifold, the pressure read is different from the pressure estimated by the control unit and the system tries to reach an "estimated" situation by opening the throttle a little bit more; therefore, this parameter takes a value different from zero: an acceptable value should be between -0.7° and +0.7°.

Front cylinder Limp home position / Rear cylinder Limp home position

Example value: 800 mV / 780 mV

Voltage stored in the control unit corresponding to the throttle Limp home position.

Front throttle lower position / Rear throttle lower position

Example value: 502 mV / 492 mV

Voltage stored in the control unit corresponding to the throttle mechanical minimum position.

AXONE: STATUSES

Throttle Self-learning

Example value: carried out/not carried out

Indicates whether or not the autodetection process has been carried out through the diagnosis instrument.

AXONE: ACTIVATIONS

-

AXONE: ELECTRICAL ERRORS

Potentiometer 1 sensor, front throttle position P0120

Example value: short circuit to positive/ open circuit, short circuit to negative

Error cause

- If shorted to positive: excessive voltage has been detected at PIN A6 of the throttle control unit. If the circuit is open, shorted to negative: voltage equal to zero has been detected at PIN A6 of the throttle control unit.

Troubleshooting

- if shorted to positive: check the value shown by the parameter of the front throttle Potentiometer 1 (voltage): disconnect the left connector and see the value displayed by Axone: if the voltage does not vary, there is a short circuit in the cable wiring; replace the throttle body if the voltage drops to zero.
- if the circuit is open, short circuit to negative: check the throttle body connector and the throttle valve connector. If not OK, restore; if everything is OK, check circuit continuity between the two terminals. If not OK, restore the cable harness; if OK, check the circuit earth insulation (from throttle sensor connector or control unit connector). If it is earth insulated, check that there is power (+5 V) at the throttle body connector PIN 2, and that PIN 6 is connected to ground. If both are correct, replace the throttle body.

Potentiometer 2 sensor, front throttle position P0122

Example value: short circuit to positive/ open circuit, short circuit to negative

Error cause

- If shorted to positive: excessive voltage has been detected at PIN A5 of the throttle control unit. If the circuit is open, shorted to negative: voltage equal to zero has been detected at PIN A5 of the throttle control unit.

Troubleshooting

- if shorted to positive: check the value shown by the parameter of the front throttle Potentiometer 2 (voltage): disconnect the left connector and see the value displayed by Axone: if the voltage does not vary, there is a short circuit in the cable wiring; replace the throttle body if the voltage drops to zero.
- if the circuit is open, short circuit to negative: check the throttle body connector and the throttle valve connector. If not OK, restore; if everything is OK, check circuit continuity between the two terminals. If not OK, restore the cable harness; if OK, check the circuit earth insulation (from throttle sensor connector or control unit connector). If it is earth insulated, check that there is power (+5 V) at the throttle body connector PIN 2, and that PIN 6 is connected to ground. If both are correct, replace the throttle body.

Potentiometer 1 sensor, rear throttle position P0125

Example value: short circuit to positive/ open circuit, short circuit to negative

Error cause

- If shorted to positive: excessive voltage has been detected at PIN B6 of the throttle control unit. If the circuit is open, shorted to negative: voltage equal to zero has been detected at PIN B6 of the throttle control unit.

Troubleshooting

- if shorted to positive: check the value shown by the parameter of the Front throttle Potentiometer 1 (voltage): disconnect the left connector and see the value displayed by Axone: if the voltage does not vary, there is a short circuit in the cable wiring; replace the throttle body if the voltage drops to zero.
- if the circuit is open, short circuit to negative: check the throttle body connector and the throttle valve connector. If not OK, restore; if everything is OK, check circuit continuity between the two terminals. If not OK, restore the cable harness; if OK, check the circuit earth insulation (from throttle sensor connector or control unit connector). If it is earth insulated, check that there is power (+5 V) at the throttle body connector PIN 2, and that PIN 6 is connected to ground. If both are correct, replace the throttle body.

Potentiometer 2 sensor, rear throttle position P0127

Example value:short circuit to positive/ open circuit, short circuit to negative

Error cause

- If shorted to positive: excessive voltage has been detected at PIN B5 of the throttle control unit. If the circuit is open, shorted to negative: voltage equal to zero has been detected at PIN B5 of the throttle control unit.

Troubleshooting

- if shorted to positive: check the value shown by the parameter of the Rear throttle Potentiometer 2 (voltage): disconnect the left connector and see the value displayed by Axone: if the voltage does not vary, there is a short circuit in the cable wiring; replace the throttle body if the voltage drops to zero.
- if the circuit is open, short circuit to negative: check the throttle body connector and the throttle valve connector. If not OK, restore; if everything is OK, check circuit continuity between the two terminals. If not OK, restore the cable harness; if OK, check the circuit earth insulation (from throttle sensor connector or control unit connector). If it is earth insulated, check that there is power (+5 V) at the throttle body connector PIN 2, and that PIN 6 is connected to ground. If both are correct, replace the throttle body.

Front throttle supply voltage during self-learning P0164

Example value:low supply voltage

Error cause

- The throttle power supply is too low to carry out the autodetection test correctly (at each key ON). The instrument panel does not indicate the presence of this error even in the ATT status.

Troubleshooting

- The throttle test is not carried out when the key is set to ON because the test could show unreal errors (because the voltage is too low). Voltage is detected by the Marelli control unit.

Front throttle control circuit P0166

Example value: short circuit to positive / short circuit to negative / open circuit, overcurrent, excessive internal temperature.

Error cause

- If shorted to positive: excessive voltage has been detected at PIN C1 of the throttle control unit connector. If shorted to negative: no voltage has been detected. If the circuit is open: an interruption has been detected.

Troubleshooting

- if shorted to positive: disconnect the throttle body connector, set key to ON and check voltage at PIN 3: if the voltage read is higher or equal to 5V, there is a short circuit on the cable harness; replace the throttle body if the voltage is null
- if shorted to negative: disconnect the throttle body connector, set the key to ON and check if PIN 3 is in continuity with the vehicle ground connection: if it is, there is a short circuit in the cable ground connection; if it is not, replace the throttle body.
- open circuit, overcurrent, excessive inside temperature: check the throttle body connector and the throttle control unit connector. If not OK, restore. If everything is OK, disconnect the throttle body connector (PIN 3) and the throttle control unit connector (C1) and check the circuit continuity between the two terminals; if there is no continuity, restore the cable harness. If there is continuity, with the throttle body connector connected, check that the resistance, from the throttle control unit connector, between PIN A1 and C1 is within 1 and 2.5 Ohm; if it is not, replace the throttle body; if it is, check that the throttle body is not mechanically blocked: if blocked, solve the problem and replace the body; if it is not, replace the throttle control unit.

Rear throttle supply voltage during self-learning P0184

Example value: low supply voltage

Error cause

- The throttle power supply is too low to carry out the autodetection test correctly (at each key ON). The instrument panel does not indicate the presence of this error even in the ATT status.

Troubleshooting

- The throttle test is not carried out when the key is set to ON because the test could show unreal errors (because the voltage is too low). Voltage is detected by the Marelli control unit.

Rear throttle control circuit P0186

Example value: short circuit to positive / short circuit to negative / open circuit, overcurrent, excessive internal temperature.

Error cause

- If shorted to positive: excessive voltage has been detected at PIN 8A of the throttle control unit connector. If shorted to negative: no voltage has been detected. If the circuit is open, there is overvoltage or excessive internal temperature: an interruption or excessive ampere input or control unit overheating has been detected.

Troubleshooting

- if shorted to positive: disconnect the throttle body connector, set key to ON and check voltage at PIN 3: if the voltage read is higher or equal to 5V, there is a short circuit on the cable harness; replace the throttle body if the voltage is null.
- if shorted to negative: disconnect the throttle body connector, set the key to ON and check if PIN 3 is in continuity with the vehicle ground connection: if it is, there is a short circuit in the cable ground connection; if it is not, replace the throttle body.
- open circuit, overvoltage, excessive inside temperature: check the throttle body connector and the throttle control unit connector. If not OK, restore. If everything is OK, disconnect the throttle body connector (PIN 3) and the throttle control unit connector (C8) and check the circuit continuity between the two terminals; if there is no continuity, restore the cable harness. If there is continuity, with the throttle body connector connected, check that the resistance, from the throttle control unit connector, between PIN A8 and C8 is within 1 and 2.5 Ohm; if it is not, replace the throttle body; if it is, check that the throttle body is not mechanically blocked: if blocked, solve the problem and replace the body; if it is not, replace the throttle control unit.

AXONE: LOGIC ERRORS

Potentiometer 1 sensor, front throttle position P0121 - signal not valid.

Error cause

- Signal not within the expected value drawn according to the values of the intake pressure.

Troubleshooting

- Check the parameter of the Potentiometer 1 Front throttle (voltage) to get which signal the control unit receives and to compare it to the Potentiometer 1 Rear throttle (voltage). Check the throttle body connector as well as the throttle control unit connector. Check that cable resistance between the throttle body connector (PIN 1) and the throttle control unit (PIN 6A)

is a few tenths of an Ohm. If this is not the case, restore the cable harness. If the value is correct, replace the complete throttle body.

Potentiometer 2 sensor, front throttle position P0123 - signal not valid.

Error cause

- Signal not within the expected value drawn according to the values of the intake pressure.

Troubleshooting

- Check the parameter of the Potentiometer 1 Front throttle (voltage) to get which signal the control unit receives and to compare it to the Potentiometer 2 Rear throttle (voltage). Check the throttle body connector as well as the throttle valve control unit connector. Check that cable resistance between the throttle body connector (PIN 4) and the throttle control unit (PIN 5A) is a few tenths of an Ohm. If this is not the case, restore the cable harness. If the value is correct, replace the complete throttle body.

Front throttle valve position sensors P0124 - illogical signal.

Error cause

- Potentiometer 1 and potentiometer 2 do not show a logical value: the sum of the two voltages should be constant. The cause may be a malfunction in one of the two sensors or an abnormal resistance in one of the two circuits.

Troubleshooting

- Check the throttle body connector as well as the throttle control unit connector. Check that cable resistance between the throttle body connector (PIN 1) and the throttle control unit (PIN 6A) is a few tenths of an Ohm. Check that cable resistance between the throttle body connector (PIN 4) and the throttle control unit (PIN 5A) is a few tenths of an Ohm. If one of the two is different, restore the cable harness. If correct, replace the complete throttle body.

Potentiometer 1 sensor, rear throttle position P0126 - signal not valid.

Error cause

- Signal not within the expected value drawn according to the values of the intake pressure.

Troubleshooting

- Check the parameter of the Potentiometer 1 Rear throttle (voltage) to get which signal the control unit receives and to compare it to the Potentiometer 1 Front throttle (voltage). Check the throttle body connector as well as the throttle control unit connector. Check that cable resistance between the throttle body connector (PIN 1) and the throttle control unit (PIN 6B) is a few tenths of an Ohm. If this is not the case, restore the cable harness. If the value is correct, replace the complete throttle body.

Potentiometer 2 sensor, rear throttle position P0128 - signal not valid.

Error cause

- Signal not within the expected value drawn according to the values of the intake pressure.

Troubleshooting

- Check the parameter of the Potentiometer 2 Rear throttle (voltage) to get which signal the control unit receives and to compare it to the Potentiometer 2 Front throttle (voltage). Check the throttle body connector as well as the throttle control unit connector. Check that cable resistance between the throttle body connector (PIN 4) and the throttle control unit (PIN 5B) is a few tenths of an Ohm. If this is not the case, restore the cable harness. If the value is correct, replace the complete throttle body.

Rear throttle position sensors P0129 - illogical signal.

Error cause

- Potentiometer 1 and potentiometer 2 do not show a logical value: the sum of the two voltages should be constant. The cause may be a malfunction in one of the two sensors or an abnormal resistance in one of the two circuits.

Troubleshooting

- Check the throttle body connector as well as the throttle control unit connector. Check that cable resistance between the throttle body connector (PIN 1) and the throttle control unit (PIN 6B) is a few tenths of an Ohm. Check that cable resistance between the throttle body connector (PIN 4) and the throttle control unit (PIN 5B) is a few tenths of an Ohm. If one of the two is different, restore the cable harness. If correct, replace the complete throttle body.

Front throttle Limp Home autodetection P0160 - test failed.

Error cause

- Throttle position, kept by the springs, not within the expected range (at each key ON). The instrument panel does not indicate the presence of this error even in the ATT status.

Troubleshooting

- Check if the throttle body and the intake duct are clean. If they are, replace the throttle body.

Front throttle mechanical springs autodetection P0161 - test failed.

Error cause

- Return time of the throttle, kept in position by the springs, not within the expected limits: the causes can be a deterioration of the performance of the springs or excessive throttle friction (at each key ON).

Troubleshooting.

- Check if the throttle body and the intake duct are clean. If they are, replace the throttle body.

Front throttle minimum mechanical position autodetection P0162 - test failed.

Error cause

- Position of the throttle stop not within the expected range (at each key ON).

Troubleshooting.

- Check if the throttle body and the intake duct are clean. If they are, replace the throttle body.

Detection of front throttle valve Recovery conditions (air T°,water T°) P0163 - possible presence of ice.

Error cause

- A correct throttle rotation cannot be detected given low ambient and engine temperatures: some ice may have formed in the duct (at each key ON). The instrument panel does not indicate the presence of this error even in the ATT status.

Troubleshooting

- Check that the throttle body is clean and that there is no ice or condensation in the intake duct. If they are, replace the throttle body.

Front throttle first self-learning NOT performed P0165 - test not carried out.

Error cause

- The first throttle self-learning process has not been successful or has not been carried out. The instrument panel does not indicate the presence of this error even in the ATT status.

Troubleshooting.

- Delete errors hindering throttle self-learning.

Front throttle position error P0167 - misalignment between control and activation.

Error cause

- The throttle mechanical control may be damaged.

Troubleshooting.

- Replace the throttle body.

Rear throttle Limp Home autodetection P0180 - test failed.

Error cause

- Throttle position, kept by the springs, not within the expected range (at each key ON). The instrument panel does not indicate the presence of this error even in the ATT status.

Troubleshooting

- Check if the throttle body and the intake duct are clean. If they are, replace the throttle body.

Rear throttle mechanical spring autodetection P0181 - test failed.

Error cause

- Return time of the throttle, kept in position by the springs, not within the expected limits: the causes can be a deterioration of the performance of the springs or excessive throttle friction (at each key ON).

Troubleshooting.

- Check if the throttle body and the intake duct are clean. If they are, replace the throttle body.

Rear throttle minimum mechanical position autodetection P0182 - test failed.

Error cause

- Position of the throttle stop not within the expected range (at each key ON).

Troubleshooting.

- Check if the throttle body and the intake duct are clean. If they are, replace the throttle body.

Detection of the rear throttle Recovery conditions (air T°, water T°) P0183 - possible presence of ice.

Error cause

- A correct throttle rotation cannot be detected given low ambient and engine temperatures: some ice may have formed in the duct (at each key ON). The instrument panel does not indicate the presence of this error even in the ATT status.

Troubleshooting

- Check that the throttle body is clean and that there is no ice or condensation in the intake duct. If they are, replace the throttle body.

Rear throttle first self-learning NOT performed P0185 - test not carried out.

Error cause

- The first throttle self-learning process has not been successful or has not been carried out. The instrument panel does not indicate the presence of this error even in the ATT status.

Troubleshooting.

- Delete errors hindering throttle self-learning.

Rear throttle position error P0187 - misalignment between control and activation.

Error cause

- The throttle mechanical control may be damaged.

Troubleshooting.

- Replace the throttle body.

RESET PROCEDURE

If the Marelli control unit or the throttle body is replaced, do not start the engine within the 3 seconds after the key is set to ON; during this time the control unit carries out the throttle self-learning process: then make sure that the throttle self-learning status reads: carried out. If the indication is "Not carried out", delete any possible errors present in the vehicle. Carry out Throttle self-learning process on the adjustable parameters screen page (screwdriver and hammer), and check again that the throttle self-learning status reads: carried out.

Engine oil pressure sensor

ENGINE OIL PRESSURE SENSOR

Function: it indicates to the instrument panel if there is enough oil pressure (0.5 +/- 0.2 bar (7.25 +/- 2.9 PSI)) in the engine.

Operation / Operating principle: normally closed switch. With oil pressure above 0.5 +/-0.2 bar (7.25 +/- 2.9 PSI), open circuit.

Location on the vehicle: right side of the vehicle, under the oil sump

Pin-out: Voltage 5V



Instrument panel

Error DSB 07

Error cause

- An oil sensor failure is signalled when, with engine off, it is detected that the sensor circuit is open. The test is performed only once when the key is set to ON. This error is signalled by the bulb icon and the general warning light turns on as well.

Troubleshooting

- Check the sensor connector and the instrument panel connector (PIN 17): If not OK, restore. If OK, check the continuity of the purple cable between the sensor connector and the instrument panel connector PIN 17: if not OK, restore the cable harness; if OK, replace the sensor.



Error DSB 08Error cause

- An oil sensor failure is signalled when, with engine running, it is detected that the sensor circuit is closed. This error is signalled by the bulb icon and the general warning light turns on as well.

Troubleshooting

- Check if oil pressure is low with the specific gauge.

Neutral sensor**GEAR IN NEUTRAL SENSOR****Function**

it tells the gear position to the control unit: in neutral or in gear.

Operation / Operating principle

for gear in neutral, the circuit is closed to ground connection: then, via CAN, the control unit sends the signal to the instrument panel which turns on the neutral speed warning light.

Level in wiring diagram: start-up enabling switches

Location:

- on the vehicle: left side of the vehicle, near flywheel cover
- connector: upper part of the flywheel cover

Electrical characteristics:

- gear in neutral: closed circuit (continuity)
- gear engaged: open circuit (infinite resistance)

Pin-out:

1. Voltage 12V

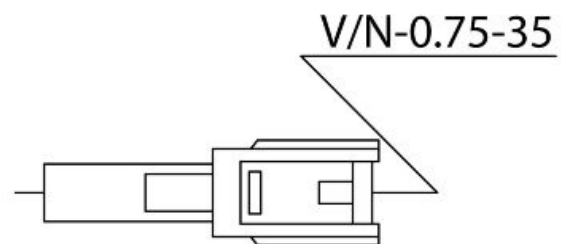
CAUTION

BEFORE CARRYING OUT ANY TROUBLESHOOTING, CAREFULLY READ THE GENERAL CONCEPTS OF ELECTRICAL TROUBLESHOOTING FOUND AT THE BEGINNING OF THE CHECKS AND CONTROLS SECTION IN THE ELECTRICAL SYSTEM CHAPTER.

AXONE: STATUSES

Gear in neutral

Example value:yes/no

AXONE: NOTES

- Indication on the instrument panel always gear engaged: check the correct position of the cable terminals on the connector and the correct connection of the cables on the terminals. If they are not correct, restore the cable harness; if correct, disconnect the connector and, with gear in neutral, check continuity to terminal ground connection, sensor side: if there is no continuity, replace the sensor (after checking cable continuity on the sensor side and the correct mechanical position). If there is, check the correct position of the terminal on the control unit connector and the correct connection of the cables on the terminals. If they are not correct, restore the cable harness; if OK, check the cable continuity between the sensor connector and ENGINE connector PIN 16: if there is no continuity, restore the cable harness. If there is, replace the instrument panel if the vehicle performance is correct (the engine starts with gear in neutral but the neutral warning light is off) or replace the control unit if the vehicle performance is not correct (the engine does not start with gear in neutral).
- Indication on the instrument panel always gear in neutral: disconnect the terminals from the sensor and check if there is continuity with ground connection at PIN toward the sensor, with gear engaged: if there is continuity, replace the sensor. If it is insulated from the ground connection, it means that the green/black cable from sensor PIN 1 to ENGINE connector PIN 16 is short circuited to ground: restore the cable harness

Clutch lever sensor

CLUTCH LEVER SENSOR

Function

It tells the clutch lever position to the control unit.

Operation / Operating principle

If there is gear engaged but the clutch is pulled, i.e. circuit closed to ground, vehicle start-up is not enabled.

Level in wiring diagram:Start-up enabling switches.

Location:

- on the vehicle: under clutch lever
- connector: on the sensor

Electrical characteristics:

- Clutch pulled: closed circuit (continuity)
- Clutch released: open circuit (infinite resistance)

Pin-out:

1. Voltage 12V
2. Ground connection

CAUTION

BEFORE CARRYING OUT ANY TROUBLE-SHOOTING, CAREFULLY READ THE GENERAL CONCEPTS OF ELECTRICAL TROUBLE-SHOOTING FOUND AT THE BEGINNING OF THE CHECKS AND CONTROLS SECTION IN THE ELECTRICAL SYSTEM CHAPTER.

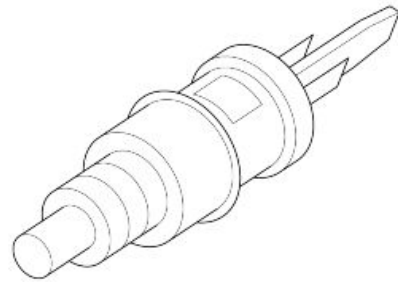
**AXONE: STATUSES****Clutch**

Example value: Indefinite - released - pulled

The statuses regularly viewed are Released / Pulled

Troubleshooting:

- Indication on Axone always Released: check the correct position of the cable terminals on the connector and the correct connection of the cables on the terminals. If they are not correct, restore the cable harness; if correct, disconnect the two terminals from the sensor and, with key set to ON, check continuity to ground connection of PIN 2: if there is no continuity, restore the cable harness; if there is, replace the sensor
 - Indication on Axone always Pulled: disconnect the terminals from the sensor and check if there is continuity between the two PINS, with clutch released: if there is continuity, replace the sensor. If the circuit is open, it means that the brown/purple cable from sensor PIN 1 to ENGINE connector PIN 50 is short circuit to ground: restore the cable harness
-

Side stand sensor

SIDE STAND SENSOR

Function

It tells the side stand position to the control unit.

Operation / Operating principle

If the gear is engaged and the side stand is unfolded, and therefore the circuit is open, the control unit does not enable vehicle start-up or shuts off the engine if it is rotating.

Level in wiring diagram: start-up enabling switches

Location:

- on the vehicle: on the side stand
- connector: left side, near the Marelli control unit

Electrical characteristics:

- Side Stand Up: closed circuit (continuity)
- Side Stand Down: open circuit (infinite resistance)

Pin-out:

1. Ground connection
2. Voltage 12V

CAUTION

BEFORE CARRYING OUT ANY TROUBLESHOOTING, CAREFULLY READ THE GENERAL CONCEPTS OF ELECTRICAL TROUBLESHOOTING FOUND AT THE BEGINNING OF THE CHECKS AND CONTROLS SECTION IN THE ELECTRICAL SYSTEM CHAPTER.

AXONE: STATUSES

Side stand

Example value: up/down

Indication on Axone **always down**: check the connector: if not OK, restore; if it is OK, disconnect the two terminals from the sensor and check continuity to ground of PIN 1: if there is no continuity, restore the cable harness; if there is, replace the sensor.

Indication on Axone **always up**: disconnect the terminals from the sensor and check if there is continuity between the two PINS, with stand down: if there is continuity, replace the sensor; if the circuit is open, it means that the brown/green cable from sensor PIN 2 to ENGINE connector PIN 6 is short circuit to ground: restore the cable harness.

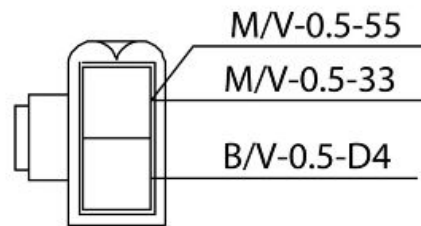

Bank angle sensor

FALL SENSOR

Function

it tells the vehicle position to the control unit.

Operation / Operating principle

When the sensor is inverted, the circuit is closed to ground: When the Marelli control unit detects this ground connection, it does not enable start-up or shuts off the engine.

Level in wiring diagram: Start-up enabling switches.

Location:

- on the vehicle: under the saddle
- connector: near the sensor

Electrical characteristics:

- Sensor in vertical position: open circuit (resistance: 62 kOhm)
- Sensor inverted: closed circuit (continuity)

Pin-out:

1. Ground connection
2. Voltage 5V

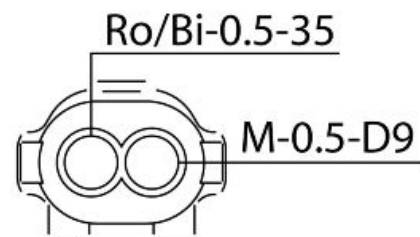
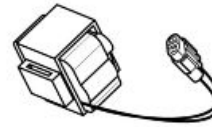

CAUTION

BEFORE CARRYING OUT ANY TROUBLESHOOTING, CAREFULLY READ THE GENERAL CONCEPTS OF ELECTRICAL TROUBLESHOOTING FOUND AT THE BEGINNING OF THE CHECKS AND CONTROLS SECTION IN THE ELECTRICAL SYSTEM CHAPTER.

AXONE: PARAMETERS

Fall sensor

Example value: Normal / Tip over

Indication on Axone always **Normal**, even when the sensor is inverted: disconnect the connector and, with sensor inverted, check if there is continuity between the two PINS of the sensor: if there is no continuity, replace the sensor; if there is, check the connector. If not OK, restore the cable harness; if OK, check continuity to ground of PIN 1: if there is no continuity, restore the cable harness; if there is, with key set to ON, check if there is 5V voltage at PIN 2. If there is not, check the Marelli control unit connector (ENGINE connector PIN 8).

Indication on Axone always **Tip over**: disconnect the connector and check if there is continuity between the two PINS when the sensor is in vertical position: if there is continuity, replace the sensor; if there is

not, it means that, with key set to ON, there is no 5V voltage at PIN 2: restore the cable harness whose pink/white cable will be short circuit to ground

Air temperature sensor - instrument panel

INSTRUMENT PANEL AIR TEMPERATURE

SENSOR

Function

It tells the ambient air temperature to the instrument panel.

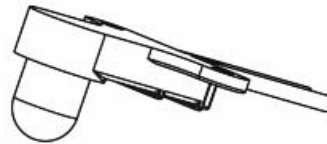

Operation / Operating principle

NTC type sensor (resistance sensor, inversely variable with temperature).

Level in wiring diagram: Temperature sensors

Location:

- on the vehicle: on the plastic protection under the instrument panel
- connector: under the instrument panel

Electrical characteristics:

- Resistance at 0°C: 32.5 kOhm +/- 5%
- Resistance at 25°C: 10.0 kOhm +/- 5%

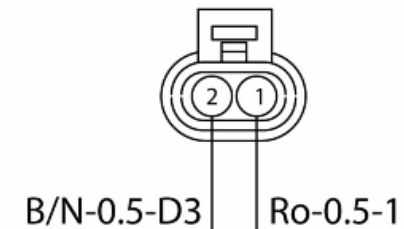

Pin-out:

1. Voltage 5V
2. Ground connection

AXONE: ELECTRICAL ERRORS

INSTRUMENT PANEL DSB 06

Error cause

- The oil sensor failure is signalled when it is detected that the sensor circuit is open or short circuit to positive.

Troubleshooting

- Check the sensor connector and the instrument panel connector (PINS 10 and 30): If not OK, restore; if OK, check the continuity of the pink cable between the sensor connector and the instrument panel connector PIN 10: if not OK, restore the cable harness; if OK, check the correct sensor resistance: if not OK, replace the sensor; if it is OK, check the continuity of the yellow/black cable between the sensor connector and the instrument panel connector PIN 30: If not OK, restore the cable harness; if OK, with key set to ON, check if there is voltage at the sensor connector PIN 1: if there is no voltage, replace the instrument panel; if there is approximately 12V, restore the cable harness (there is a short circuit in the battery).

If there is 5V voltage, connect a 10 kOhm resistance to sensor connector PIN 1 and to the vehicle ground connection: if, with key set to ON, the voltage measured upstream the resistance decreases, replace the instrument panel. If voltage continues to be approximately 5V, restore the pink cable (there is a short circuit at + 5V)

Notes

If a short circuit to ground is detected at instrument panel connector PIN 10, the display will shown a full scale indication ????? of air temperature.

Check the earth insulation of the sensor connector pink cable: if there is a connection, restore the cable harness; if it is earth insulated, check that sensor resistance is correct: if not OK, replace the sensor; if it is OK, replace the instrument panel

Electric fan circuit**ELECTRIC FAN CIRCUIT****Function**

Radiator fan and coolant - Operation.

Operation / Operating principle

When the control unit detects a temperature of approx. 102 °C, it closes the fan control relay pickup circuit to ground.

Level in wiring diagram:electric fan

Location:

- the relay is located under the fuel tank, left side, first front relay (CHECK, however, the identification of the relay with the colour of the cables).

Electrical characteristics:

- relay normally open;
- drive coil resistance 110 Ohm (+/- 10 %)

AXONE: STATUSES**Fan relay**

Example value:on/off

AXONE: ACTIVATIONS**Fan:**

The fan relay (No. 44 in the wiring diagram, placed under fuel tank, left side, first front relay; CHECK, however, the identification of the relay with the colour of the cables) is energised for 10 seconds. The continuity of the wiring is necessary for correct activation: no error indications are displayed in case of lack of activation.

AXONE: ELECTRICAL ERRORS

Cooling fan relay P0480 - short circuit to positive / short circuit to negative / open circuit.

Error cause

- If shorted to positive: excessive voltage has been detected at PIN 54 of the VEHICLE connector.
- If shorted to negative: short circuit to ground detected.
- If the circuit is open: interrupted circuit detected. Excessive voltage can only be detected after the fan relay gets activated.

Troubleshooting

- If shorted to positive: check the relay electrical specifications are correct by disconnecting it from the cable harness. If they are not correct, replace the relay; if correct, restore the cable harness (pink/blue cable).
- If shorted to negative: check the relay electrical specifications are correct by disconnecting it from the cable harness. If they are not correct, replace the relay; if correct, restore the cable harness (pink/blue cable).
- If the circuit is open: check the relay connector and the Marelli control unit VEHICLE connector: If not OK, restore; if OK, restore the cable harness (red/blue cable).



RUN/STOP switch

Run / stop switch

Function

It tells the control unit if the driver wishes to enable engine start-up or to keep the engine running.

Operation / Operating principle

If the driver wants to shut off the engine or to disable engine start-up, the switch should be open, i.e. the Marelli control unit should not detect voltage at VEHICLE connector PIN 2.

Level in wiring diagram: Start-up enabling switches.

Location:



- on the vehicle: right light switch
- connector: inside the rubber protection located between the water radiator and the fuel tank, to the right.

Electrical characteristics:

- STOP position: the circuit is open
- RUN position: closed circuit (continuity)

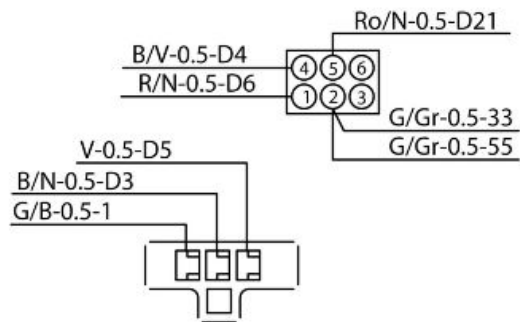
**Pin-out:**

1. Yellow/grey cable: -
2. Red/black cable: Voltage 12V

CAUTION

BEFORE CARRYING OUT ANY TROUBLESHOOTING, CAREFULLY READ THE GENERAL CONCEPTS OF ELECTRICAL TROUBLESHOOTING FOUND AT THE BEGINNING OF THE CHECKS AND CONTROLS SECTION IN THE ELECTRICAL SYSTEM CHAPTER.

AXONE: PARAMETERS

-

AXONE: STATUSES**Run / stop switch****Example value:**Run/Stop

Indication on Axone always STOP: disconnect the connector and, with the switch set to RUN, check if there is continuity toward the switch of the two yellow/grey and red/black cables: if there is no continuity, replace the sensor; if there is, check the connector. If not OK, restore the cable harness; if it is OK, with key set to ON, check if there is voltage to the red/black cable: if there is no voltage, restore the cable harness; if there is, check the yellow/grey cable earth insulation: if there is continuity to ground, restore the cable harness; if it is correct, take the key to OFF and check the VEHICLE connector is in good conditions and the continuity of the grey/yellow cable between the sensor in question and the VEHICLE connector PIN 26: if not OK, restore the cable harness; if OK, replace the Marelli control unit.

Indication on Axone always RUN: disconnect the connector and, with the switch set to STOP, check if there is continuity between the two cables of the switch: if there is continuity, replace the switch; if there is not, it means that, with key set to ON, the yellow/grey cable is short circuit to positive: restore the cable harness.

Throttle control unit**THROTTLE CONTROL UNIT****Function**

It receives the throttles target position from the Marelli control unit and it moves them so that they reach that target by reading their position through the potentiometers (2 per throttle body).

Level in wiring diagram: throttle control unit

Location:

- on the vehicle: inside the filter casing
- connector: on the control unit

Pin-out: see the CONNECTORS section

See also

[Throttle control unit](#)

Connectors

ECU

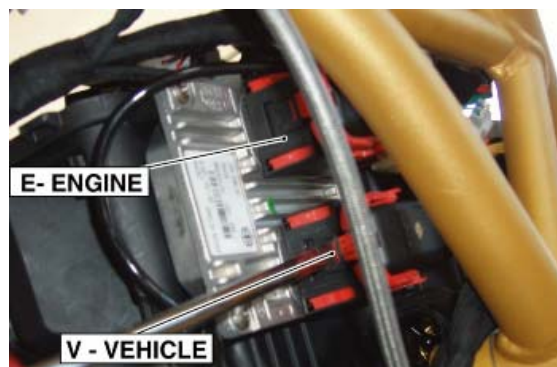

MARELLI CONTROL UNIT PIN OUT

	Specification	Desc./Quantity
1	Key switch	Vehicle connector: 12/29
2	Revolution sensor input (+)	Engine connector: 9
3	Revolution sensor input (-)	Engine connector: 23
4	Vehicle speed input	Vehicle connector: 49
5	Throttle grip input - Track A	Vehicle connector: 42
6	Throttle grip input - Track B	Vehicle connector: 40
7	Throttle grip input - Track C	Engine connector: 30
8	Throttle grip input - Track D	Engine connector: 44
9	Front cylinder intake pressure sensor input	Vehicle connector: 34
10	Rear cylinder intake pressure sensor input	Vehicle connector: 5
11	Water temperature sensor input	Engine connector: 45

	Specification	Desc./Quantity
12	Side stand input	Vehicle connector: 6
13	"start engine" input	Vehicle connector: 14
14	Clutch sensor input	Vehicle connector: 50
15	Fall sensor input	Engine connector: 8
16	Gear/neutral input	Engine connector: 16
17	Start-up control output	Engine connector: 2
18	Serial line K for diagnosis	Vehicle connector: 10
19	Auxiliary injection relay control output	Vehicle connector: 62
20	Front coil control output	Engine connector: 17
21	Rear coil control output	Engine connector: 19
22	Front injector control output	Engine connector: 50
23	Rear injector control output	Engine connector: 34
24	Air temperature sensor input	Engine connector: 63
25	Front throttle reset output	Vehicle connector: 56
26	Rear throttle reset output	Vehicle connector: 55
27	"Engine stop" input	Vehicle connector: 26
28	Electric fan relay control output	Vehicle connector: 54
29	STOP light relay control output	Vehicle connector: 59
30	Lambda heater control output	Engine connector: 32
31	Lambda sensor input (+)	Engine connector: 43
32	Lambda sensor input (-)	Engine connector: 60
33	Purge Canister valve control output (optional)	Engine connector: 51
34	Control unit direct power supply	Vehicle connector: 16
35	Power ground connection 1	Engine connector: 21
36	Power ground connection 2	Engine connector: 5
37	Power ground connection 3	Engine connector: 22
38	Power ground connection 4	Engine connector: 6
39	Reference voltage output +5V: tracks A-C and pressure sensor	Engine connector: 15
40	Reference voltage output +5V: tracks B-D and speed sensor	Engine connector: 13
41	Analogue ground connection 1	Engine connector: 35
42	Analogue ground connection 2	Vehicle connector: 46 Engine connector: 36
43	CAN H Line (high speed)	Vehicle connector: 51
44	CAN L Line (high speed)	Vehicle connector: 20

NOTE

THE CONNECTOR CAN BE VIEWED FROM THE CABLE HARNESS SIDE, THAT IS LOOKING AT THE CABLES WHEN GOING OUT OF THE "MAIN" CABLE HARNESS AND INTO THE CONNECTOR.

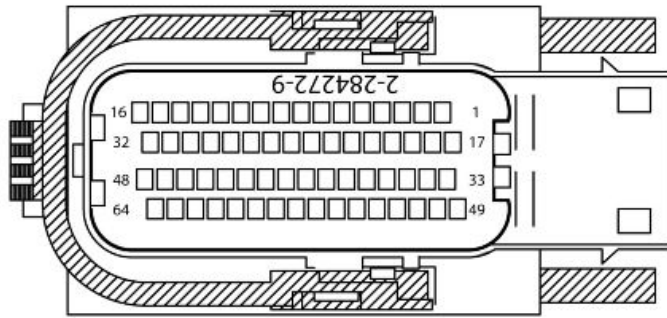

ECU "E" (Bi)

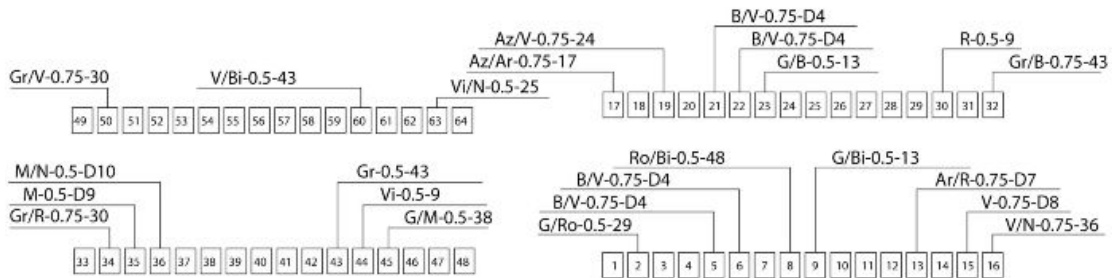

NOTE

THE CONNECTOR CAN BE VIEWED FROM THE CABLE HARNESS SIDE, THAT IS LOOKING AT THE CABLES WHEN GOING OUT OF THE "MAIN" CABLE HARNESS AND INTO THE CONNECTOR.

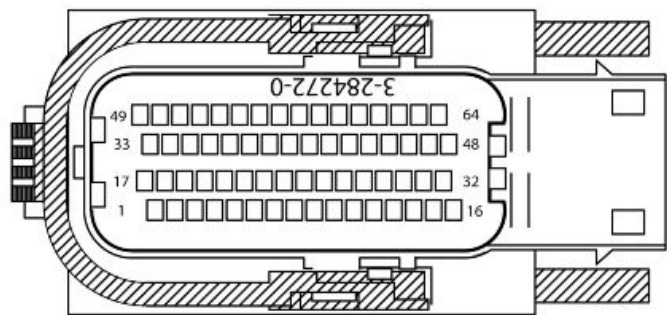

ECU "V" (G)

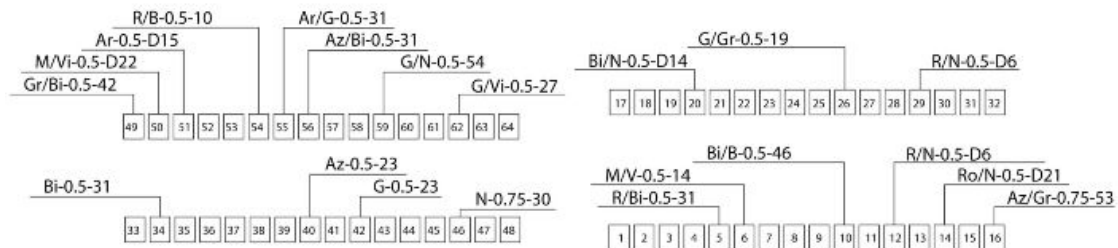

Throttle control unit



EFI THROTTLE CONTROL UNIT PIN OUT

	Specification	Desc./Quantity
1	1A - Front throttle motor control (-)	Front throttle body PIN: 5
2	2A - CAN L	
3	3A - Voltage for front throttle potentiometers (+ 5 V)	Front throttle body PIN: 2
4	4A - Key input	
5	5A - Input for front throttle potentiometer 2 signal	Front throttle body PIN: 4
6	6A - Input for front throttle potentiometer 1 signal	Front throttle body PIN: 1
7	7A - Front throttle reset signal input	
8	8A - Rear throttle motor control (+)	Rear throttle body PIN: 3
9	1B - Battery power supply input	
10	2B - CAN H	
11	3B - Voltage for rear throttle potentiometers (+ 5 V)	Rear throttle body PIN: 2
12	4B - Firmware reprogramming power supply	
13	5B - Input for rear throttle potentiometer 2 signal	Rear throttle body PIN: 4
14	6B - Input for rear throttle potentiometer 1 signal	Rear throttle body PIN: 1
15	7B - Rear throttle reset signal input	
16	8B - Battery power supply input	
17	1C - Front throttle motor control (+)	Front throttle body PIN: 3
18	2C - Ground connection	
19	3C - Ground connection	Front throttle body PIN: 6
20	4C - Ground connection	Rear throttle body PIN: 6
21	5C - Ground connection	
22	6C - Ground connection	
23	7C - Ground connection	
24	8C - Rear throttle motor control (-)	Rear throttle body PIN: 5

NOTE

THE CONNECTOR CAN BE VIEWED FROM THE CABLE HARNESS SIDE, THAT IS LOOKING AT THE CABLES WHEN GOING OUT OF THE "MAIN" CABLE HARNESS AND INTO THE CONNECTOR.

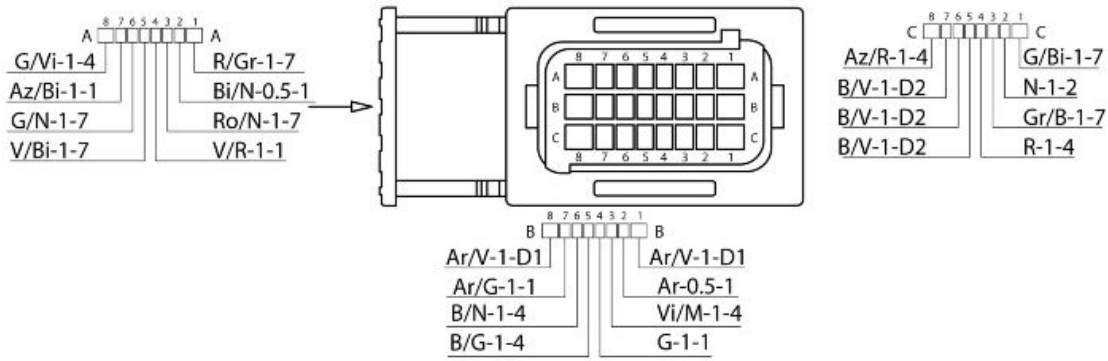

Dashboard

INSTRUMENT PANEL PIN

	Specification	Desc./Quantity
1	GREY BODY: + Live	PIN 1
2	GREY BODY: Right indicator control	PIN 2
3	GREY BODY: *	PIN 3
4	GREY BODY: High-beam lights input	PIN 4
5	GREY BODY: *	PIN 5
6	GREY BODY: Select 3 (Set)	PIN 6
7	GREY BODY: Select 2 (Down)	PIN 7
8	GREY BODY: Select 1 (Up)	PIN 8
9	GREY BODY: Fuel reserve sensor	PIN 9
10	GREY BODY: Ambient temperature sensor	PIN 10
11	GREY BODY: + Battery	PIN 11
12	GREY BODY: Left indicator control	PIN 12
13	GREY BODY: Hazard control	PIN 13
14	GREY BODY: *	PIN 14
15	GREY BODY: *	PIN 15
16	GREY BODY: Indicator reset	PIN 16
17	GREY BODY: Oil sensor input	PIN 17
18	GREY BODY: 750/1200 Selection	PIN 18
19	GREY BODY: *	PIN 19
20	GREY BODY: K Line	PIN 20
21	BLACK BODY: + Battery	PIN 21
22	BLACK BODY: Front left turn indicator activation	PIN 22
23	BLACK BODY: Front right turn indicator activation	PIN 23
24	BLACK BODY: Aerial 2	PIN 24
25	BLACK BODY: *	PIN 25
26	BLACK BODY: CAN H	PIN 26
27	BLACK BODY: CAN L	PIN 27
28	BLACK BODY: ABS warning light input	PIN 28
29	BLACK BODY: *	PIN 29
30	BLACK BODY: Ground for sensors	PIN 30
31	BLACK BODY: + Battery	PIN 31
32	BLACK BODY: Rear left turn indicator activation	PIN 32
33	BLACK BODY: Rear right turn indicator activation	PIN 33

	Specification	Desc./Quantity
34	BLACK BODY: Aerial 1	PIN 34
35	BLACK BODY: Light relay activation	PIN 35
36	BLACK BODY: *	PIN 36
37	BLACK BODY: *	PIN 37
38	BLACK BODY: General ground	PIN 38
39	BLACK BODY: General ground	PIN 39
40	BLACK BODY: General ground	PIN 40

NOTE

THE CONNECTOR CAN BE VIEWED FROM THE CABLE HARNESS SIDE, THAT IS LOOKING AT THE CABLES WHEN GOING OUT OF THE "MAIN" CABLE HARNESS AND INTO THE CONNECTOR.

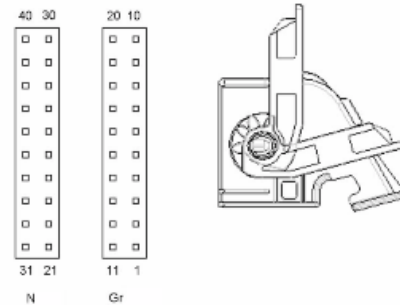

Can line

CAN line

Function

It allows communication between the Marelli injection control unit, the throttle control unit and the instrument panel.

Level in wiring diagram: CAN line

Pin-out: see wiring diagram

AXONE: ELECTRICAL ERRORS

U1602 CAN line without signals - Bus Off.

Error cause

- No communication on CAN line (PIN 20 and/or PIN 51 VEHICLE): problem on the whole network (for example, battery cut-off or short circuited or shorted to ground).

Troubleshooting

- Check the Marelli control unit VEHICLE connector: if not OK, restore; if OK, check the earth insulation of the two CAN lines from PIN 20 and PIN 51 of the VEHICLE connector: If not OK, restore the cable harness; if OK, check continuity of the two CAN lines from the Marelli control unit VEHICLE connector to the filter casing large connector and to the instrument panel connector: if not OK, restore the cable harness; if OK, check that the two lines are not short circuited to positive testing each of the 3 connectors (Marelli control unit connector, filter casing large connector and instrument panel connector) with 1 connector disconnected at a time and by setting the key to ON: If not OK, restore; if OK, replace the Marelli control unit.

Mute Node CAN Line, U1601 - Mute Node

Error cause

- The injection ECU cannot send CAN signals; it receives signals from the instrument panel and the throttle control unit: the control unit may need replacing.

Troubleshooting

- Replace the Marelli control unit.

CAN line to instrument panel, U1701 - no signalError cause

- No signal is received from the instrument panel.

Troubleshooting

- Check the connector of the instrument panel: if not OK, restore; if OK, check the continuity of the two lines from the instrument panel connector to the VEHICLE connector of the Marelli control unit: if not OK, restore the cable harness; if OK, replace the instrument panel.

CAN line to the throttle control unit, U1705 - no signalError cause

- No signal is received by the throttle control unit.

Troubleshooting

- Check the filter housing large connector and the throttle control unit connector: if not OK, restore; if OK, check the continuity of the two lines from the filter housing large connector to the VEHICLE connector of the Marelli control unit: if not OK, restore the cable harness; if OK, check the continuity of the two lines from the filter housing large connector to the throttle control unit connector: if not OK, restore the cable harness; if OK, replace the throttle control unit.

AXONE: LOGIC ERRORS**CAN Line to throttle control unit, U1706 - no message update.**Error cause

- No updated signal is received from the throttle control unit.
-

INDEX OF TOPICS

ENGINE FROM VEHICLE

ENG VE

Vehicle preparation

- Remove the air filter case.
- Remove the coolant radiator.
- Remove the exhaust system.
- Place the optional under-ump and rear wheel service stands.
- Undo and remove the screw and move the coil.



- Disconnect the engine temperature sensor connector.



- Disconnect the horn connectors.
- Disconnect the engine oil pressure sensor connector.



- Disconnect the starter motor power supply cable.



- Undo and remove the screw and collect the washer.
- Disconnect the ground leads.



- Move the breather pipe.



- Disconnect the speed sensor connector.



- Undo and remove the three screws.
- Remove the clutch control cylinder.
- Lock the plunger using a clamp.

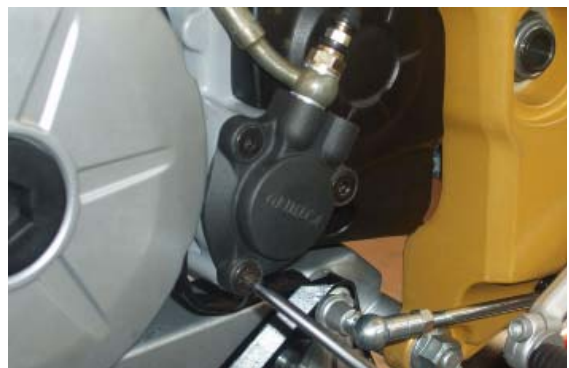

- Undo and remove the two screws.
- Remove the chain guard.



- Undo and remove the three screws fixing the chain guide.
- Remove the clutch pin.

CAUTION

UPON REFITTING, PROPERLY GREASE THE O-RING INDICATED WITH THE ARROW AND BE CAREFUL NOT TO PINCH IT.

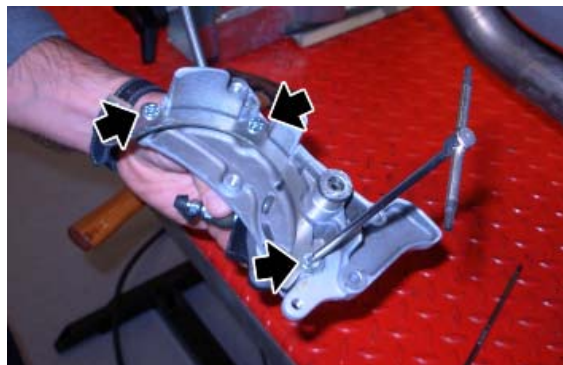

- Disconnect the gear in neutral sensor connector.



- Disconnect the side stand sensor connector.

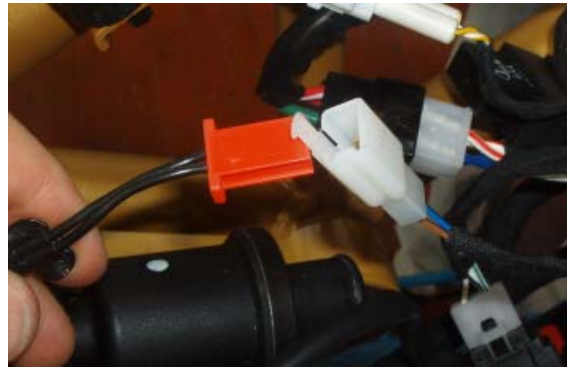

- Loosen the screw and slide off the gear transmission connecting rod keeping it linked to the gear shift lever through the rod.



- Slacken the gearing chain tension.
- Undo and remove the screw; collect the washer and the spacer.
- Slide off the pinion from the chain and remove.



- Disconnect the generator connections.

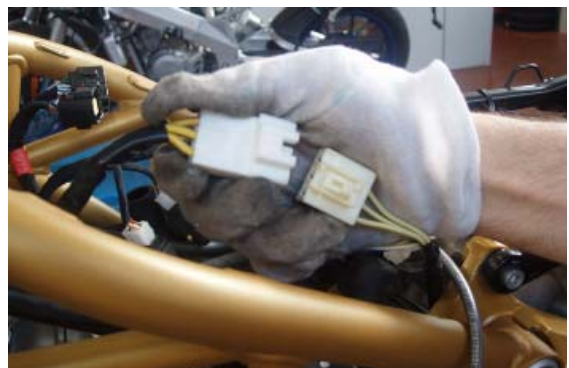



See also

[Air box](#)

[Removing the radiator](#)

Removing the engine from the vehicle

- Carry out the operations described under Vehicle preparation.
- Support the engine by means of belt and hoist.
- Working on the left side, unscrew and remove the three nuts.

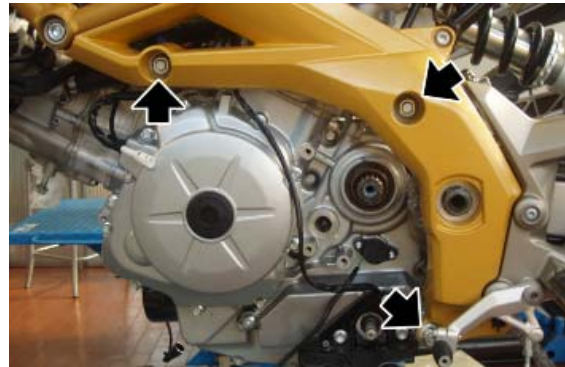

- Working on the right side, slightly slide off the three bolts.
- Collect the spacers on the opposite side.
- Check the spacer sizes so as not to interchange them upon refitting.
- Slide off the three bolts completely and collect their washers.
- Lower the engine.

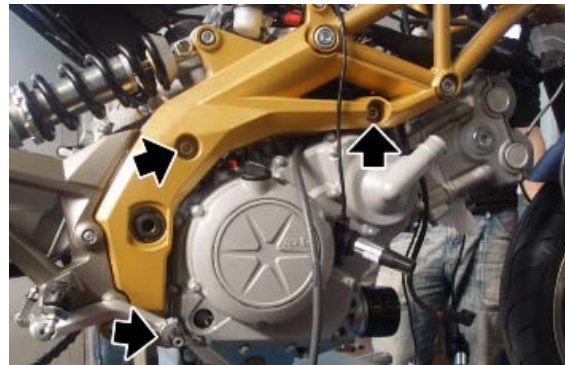

See also

[Vehicle preparation](#)

Installing the engine to the vehicle

- Place the engine on a suitable lower stand.
- Lift the engine.
- Place the engine so that the rear attachments on the chassis are aligned.

- Working on the right side, insert the three bolts with their washers.
- Working on the right side, place the spacers on the three bolts between the engine block and the chassis.

CAUTION

THE SPACERS HAVE DIFFERENT SIZES. RE-FIT THEM IN THE SAME WAY THEY WERE BEFORE BEING REMOVED.

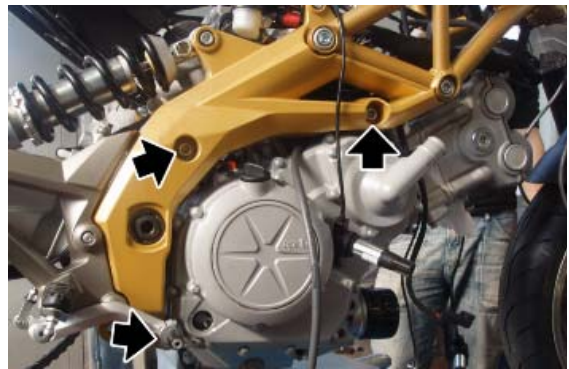

- Working from the left side, tighten the three nuts.
- Release the engine from the belt and the hoist.
- Refit the pinion and restore the gearing chain clearance.
- Reconnect the electric connections and clamp the cable harnesses.
- Carry out the vehicle preparation operations but in reverse order, restore the correct level of all fluids and carry out the adjustments that may be required.

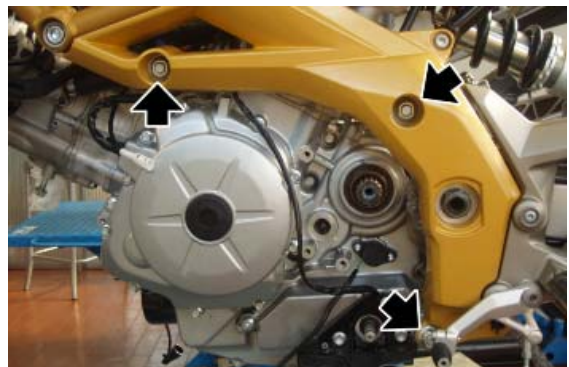
**See also**

[Vehicle preparation](#)
[Adjusting](#)

INDEX OF TOPICS

ENGINE

ENG

Gearbox

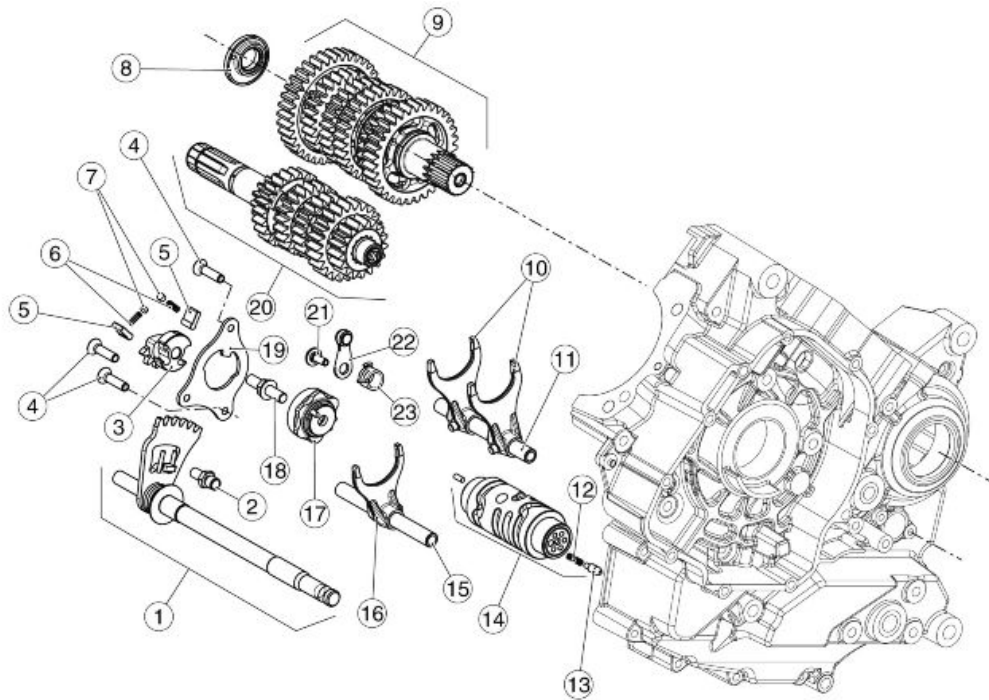
Diagram**Key**

1. Complete gear shaft and spring
2. Selector lock
3. Selector sprocket wheel
4. M5x16 Screw
5. Sprocket wheel pawl
6. Spring
7. Pin for spring
8. Tone wheel
9. Complete transmission gear shaft
10. Forks
11. Fork shaft
12. Spring
13. Pin for spring
14. Gear selector
15. Fork shaft
16. Fork

- 17. Gear selector drum
- 18. M8x1.25 threaded pin
- 19. Selector locking plate
- 20. Complete main gear shaft
- 21. TE flanged screw, M6x15
- 22. Complete index lever
- 23. Spring

Gearbox shafts

Gearbox shafts diagram

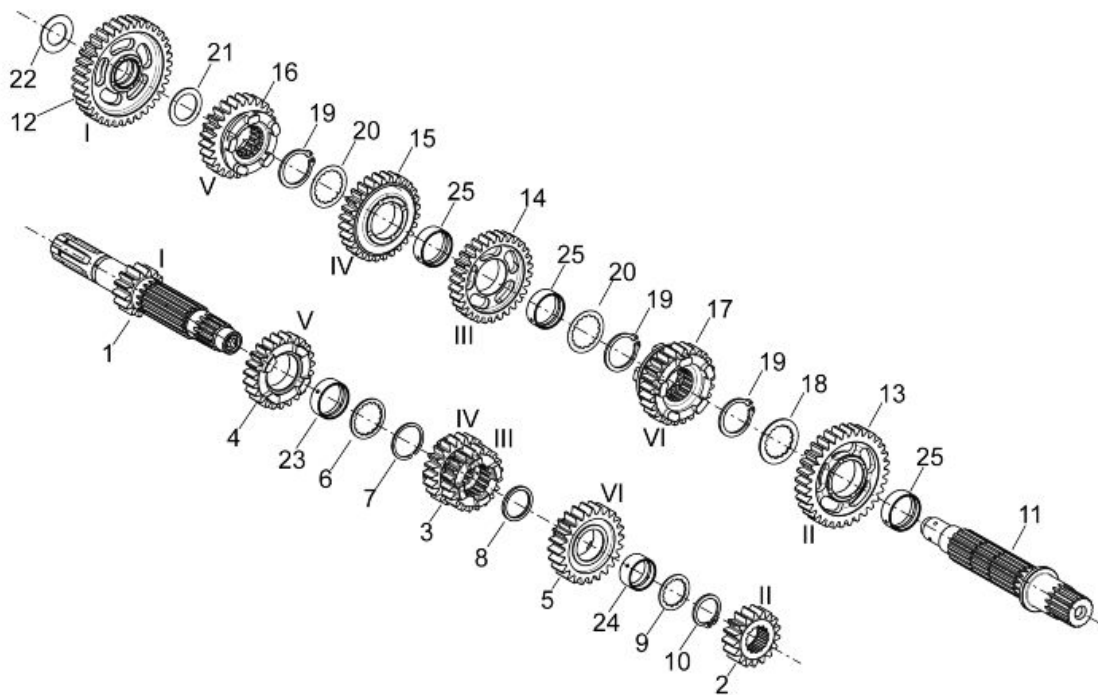

Key:

- 1. Main gear shaft Z=14
- 2. 2nd gear on primary Z=17
- 3. 3rd - 4th gear on secondary Z=20/22
- 4. 5th gear on primary Z=23
- 5. 6th gear on primary Z=24
- 6. Thrust washer
- 7. Circlip
- 8. Thrust washer
- 9. Thrust washer

10. Circlip
11. Transmission shaft
12. 1st gear on primary Z=36
13. 2nd gear on secondary Z=32
14. 3rd gear on secondary Z=30
15. 4th gear on secondary Z=28
16. 5th gear on secondary Z=26
17. 6th gear on secondary Z=25
18. Thrust washer
19. Circlip
20. Thrust washer
21. Thrust washer
22. Thrust washer
23. Floating bushing
24. Floating bushing
25. Floating bushing

Disassembling the gearbox

- Remove the gear selector as described in the Crankcase Opening section.
- Remove the two bolts of the forks.



- Slide off the desmodromic drum control.



- Remove the three gear selection forks.

CAUTION

THE MAIN SHAFT FORK IS SMALLER THAN THOSE OF THE SECONDARY SHAFT. ALL THE SECONDARY SHAFT FORKS ARE THE SAME SIZE.



- Carefully rotate the engine support.

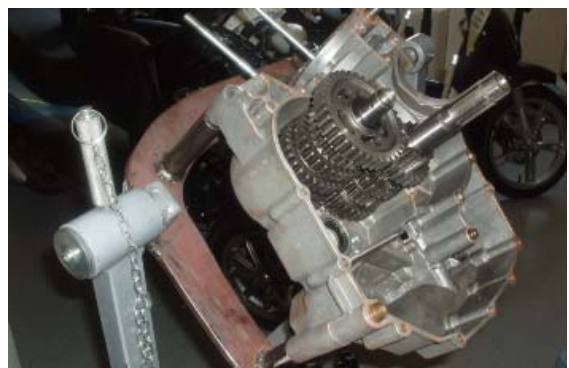

- Carefully slide off the whole gear unit.



Refitting

- Repeat the removal operations but in reverse order, make sure that the shim washer is fitted to the secondary shaft.



See also

[Splitting the crankcase halves](#)

Gear selector

Removing the gear selector

To remove the gear selector refer to the operations described under Crankcase opening.

Checking the gear selector

Selector spring

Make sure that the spring ends on the two shifting positions (forward = downshifting and backward = up-shifting) are always in contact with the selector plate

Make sure that the clearance between the end of the spring on the selector plate and the stop pin is almost null, when in home position (see diagrams)

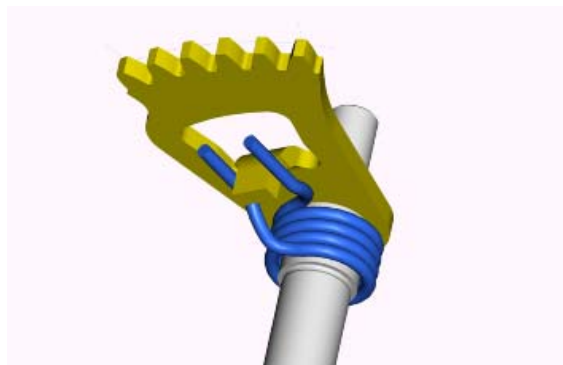

Pawl

Make sure that both pawl tips run free, without jamming

**Selector plate spring**

With a thickness gauge, check that the spring is not deformed by over-stretching.

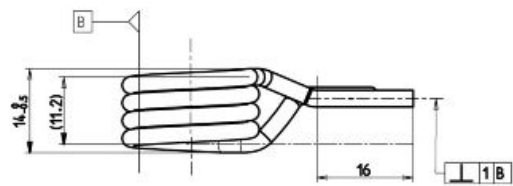
**Starter motor****Removing the starter motor**

- Disconnect the starter motor power supply cable.



- Undo and remove the four screws and remove the starter motor.

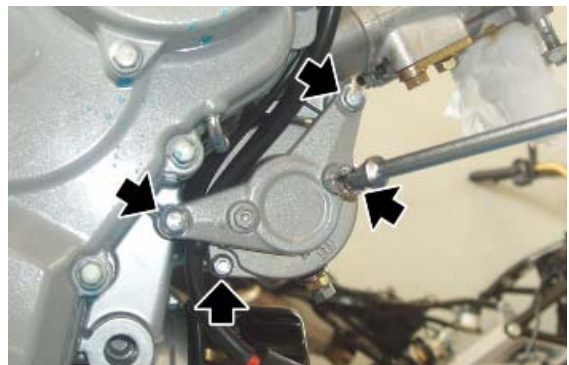

Generator side

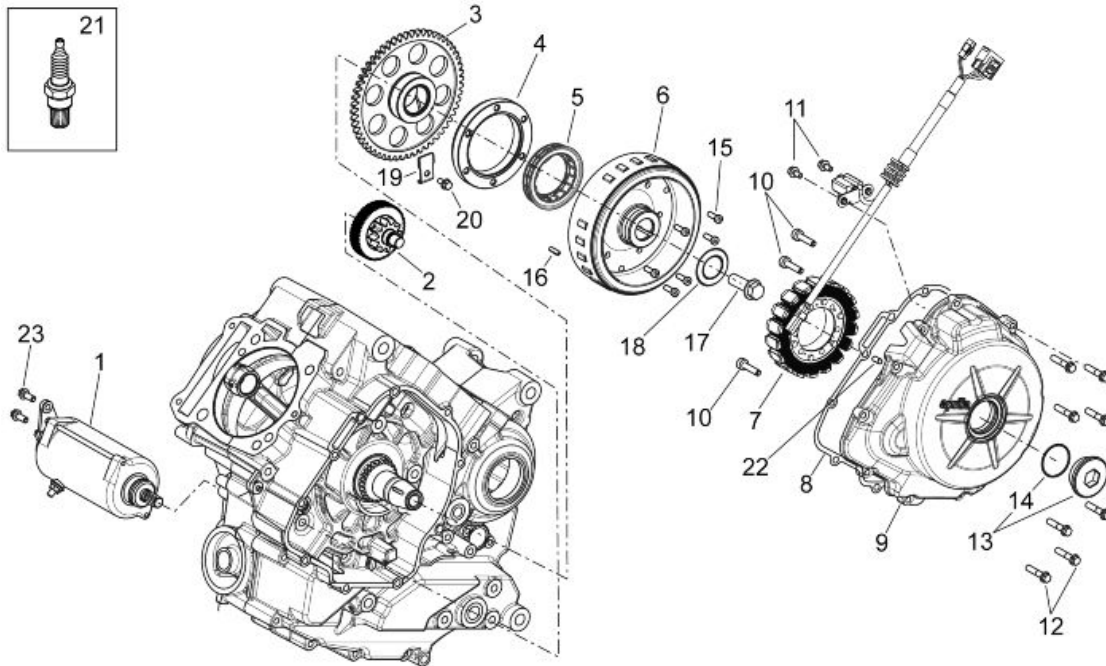

Key:

- 1. Complete starter motor
- 2. Complete torque limiter
- 3. Starting ring gear
- 4. Freewheel flange
- 5. Freewheel
- 6. Complete rotor
- 7. Complete stator
- 8. Flywheel cover gasket
- 9. Flywheel cover
- 10. TCEI low head screw M6x30
- 11. TBIC screw M5x12
- 12. TE flanged screw
- 13. Cap
- 14. Gasket
- 15. TCEI screw M6X18
- 16. Woodruff Key
- 17. TE flanged screw
- 18. Washer

19. Plate

20. TE flanged screw

21. NGK R CR7EK spark plug

22. Reference dowel

23. TE flanged screw

Removing the flywheel cover

- Remove the flywheel cover inspection cap.



- Unscrew and remove the ten screws (1 - 2).

NOTE

THE FLYWHEEL COVER SCREW (2) IS SHORTER THAN SCREWS (1).



- Use the specific tool to remove the flywheel cover.

Specific tooling

020712Y Handle for Flywheel cover removal



Removing the flywheel cover components

- Remove the two pick-up fixing screws.



- Remove the three stator fixing screws.

CAUTION

THE PICK-UP AND STATOR SHALL BE REMOVED SIMULTANEOUSLY AS THEY ARE PART OF THE SAME ELECTRICAL BRANCH.



Magneto flywheel removal

- Remove the flywheel cover.
- Undo and remove the screw and remove the retention plate.



- Heat the magneto flywheel with the specific heater.
- Lock the flywheel using the specific tool and loosen the screw.

Specific tooling

020713Y Flywheel extractor



- Screw the anticlockwise bolt of the special tool on the external body.
- Keeping the external body blocked and gripping the key, screw the anticlockwise bolt so as to remove the flywheel from the crankshaft.



Specific tooling

020713Y Flywheel extractor

- Unscrew and remove the anticlockwise bolt of the special tool from the external body.
- Undo the screw from the crankshaft.

Specific tooling

020713Y Flywheel extractor

- Remove the flywheel together with the freewheel.



- Remove the start-up transmission gear.
- In case of malfunction, the start-up transmission gear cannot be overhauled. Therefore, the complete transmission gear should be replaced.



- Collect the crankshaft woodruff key.



Freewheel removal

- Heat the magneto flywheel with the specific heater.
- Undo and remove the six screws.
- Remove the freewheel from the magneto flywheel.



Installing the flywheel

- Insert the woodruff key on the crankshaft.



- Insert the start-up transmission gear after applying a layer of grease.



- Insert the flywheel on the crankshaft.
- Screw the screw together with the washer but without tightening.



- Place the appropriate tool for locking the flywheel.
- Locking the flywheel in position, using the specific tool, tighten the screw on the crankshaft.
- Remove the special tool.

**Specific tooling****020713Y Flywheel extractor****Locking torques (N*m)****Screw fixing Rotor - Crankshaft - M12x1.25 (1)
120 Nm (88.51 lbf ft)**

- Place the retention plate.
- Tighten the screw.

**Clutch side**

- Remove the water pump cover.
- Undo and remove the eleven screws working in a diagonal sequence.
- Collect the gasket.



Removing the clutch cover

- Undo and remove the side fixing screws.
- Remove the clutch cover.

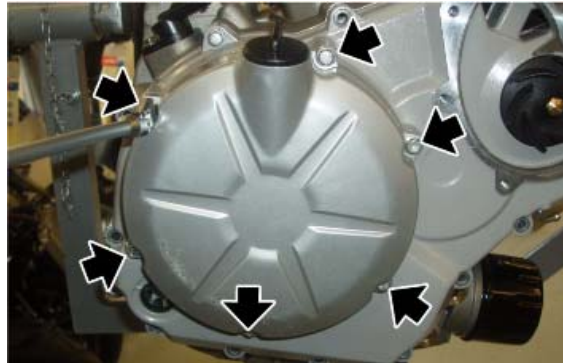

It is advisable to remove only the clutch cover in order to replace the clutch discs. Should the complete clutch assembly be removed, remove the crankcase, clutch side.

It is however possible to remove the complete clutch assembly by removing only the clutch cover.

In this case carry out the following operations:

- measure the clutch bell protrusion from the crankcase before removal;
- during refitting, first check that the measurement has not changed, then tighten the clutch nut. If it has changed, rotate the crankshaft so that the oil pump control drive gear engages correctly with the oil pump driven gear on the clutch bell.

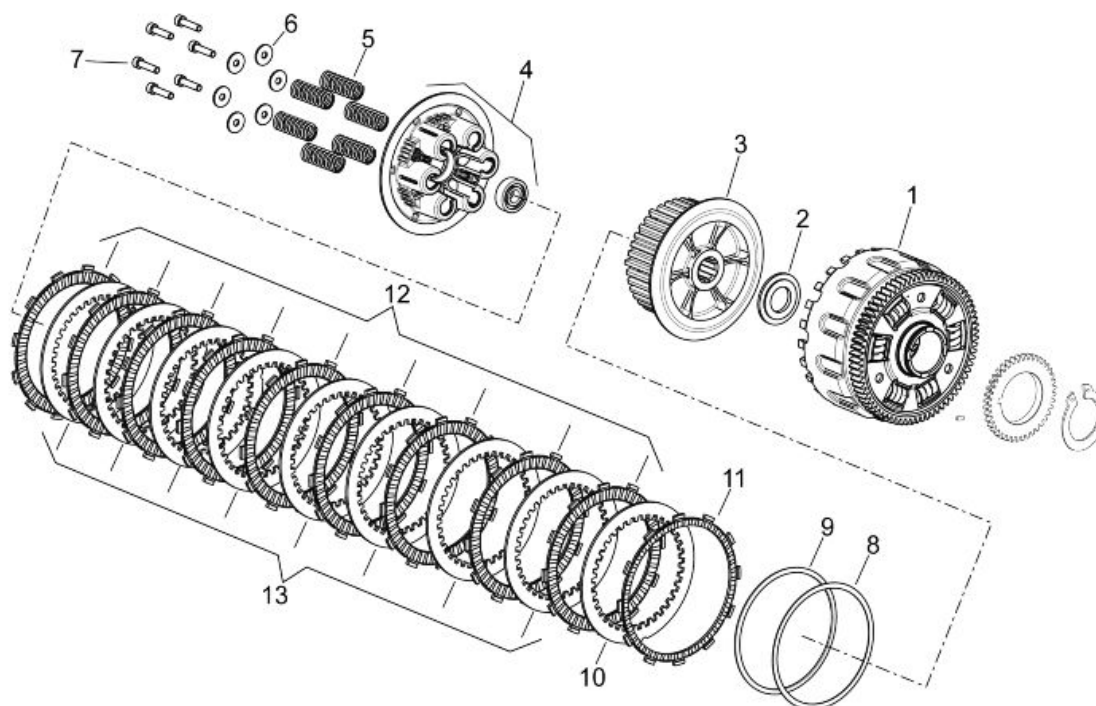

Disassembling the clutch

**Key:**

1. Complete clutch bell
2. Washer
3. Clutch hub
4. Clutch pressure plate
5. Clutch spring
6. Washer
7. TCEI screw M6
8. Spacer
9. Anti-juddering
10. Belleville spring
11. Anti-juddering
12. Nitrided driven disc
13. Lathed drive disc
14. Drive disc
15. Driven disc

- Remove the clutch side crankcase half.
- Undo and remove the six screws by loosening them 1/4 of a turn at a time; operate in stages and diagonally, and collect the washers and the clutch springs.



- Remove the pressure plate.



- Remove the mushroom rod for clutch control.



- Remove the discs.
- Remove the spacer and the belleville spring.



- Lock the clutch bell using the specific tool.

Specific tooling

9100896 Clutch bell locking tool



- Unscrew and remove the clutch hub nut and collect the washer.



- Remove the clutch hub.



- Collect the special washer between the clutch hub and the bell.
- Collect the clutch bell.



- Collect the spacer and the needle bearings.



- Collect the shim washer.



Checking the clutch plates

- Lay the friction discs and steel discs on a level surface and check them for cracks and potential distortions.

Maximum distortion allowed: 0.20 mm (0.0079 in)

- Measure the driving plate thickness at four positions, replace them all if not complying with specifications.

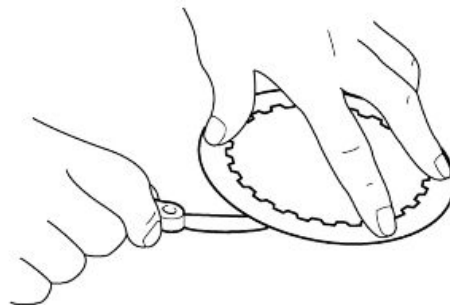

CAUTION

THE STEEL DISCS MUST SHOW NO SCORES OR TEMPERING COLOUR.

- Measure the thickness of the clutch discs at four positions, replace them if not complying with specifications.

Thickness of nine drive discs: 2.5 mm (0.10 in).
Driven disc thickness: 2.95 ÷ 3.05 mm (0.116 ÷ 0.120 in)

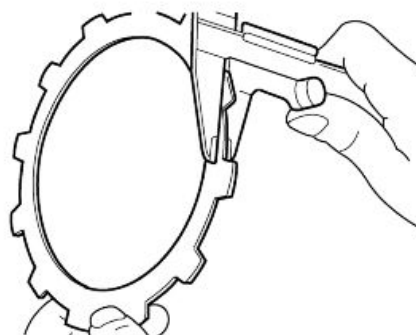

MUSHROOM VALVE CHECK

- Check if the valve slides freely, without jamming.
- Blow compressed air into the valve and check that the lubricating oil passage holes open.

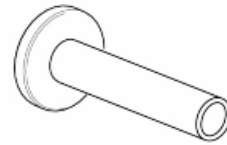
**Checking the clutch housing**

- Remove the clutch bell.
- Remove the seeger ring.



- Remove the oil pump control gear.



UPON REFITTING, THE GEAR COLLAR MUST ALWAYS BE FACING THE CLUTCH BELL.



- Remove the rotation locking pin from the oil pump control gear.



Check the clutch bell for damage and wear that may result in clutch irregular operation. Deburr the teeth or replace the bell.

MAIN DRIVEN GEAR CHECK

Check the main driven gear for damage and wear and, if necessary, replace the main transmission driving gear and the clutch bell all together.

Make sure there is not excessive noise during operation; if necessary, replace the main transmission driving gear and the clutch bell all together.

Checking the pusher plate

Check the pressure plate and the bearing for damage and wear. If necessary, replace the parts.

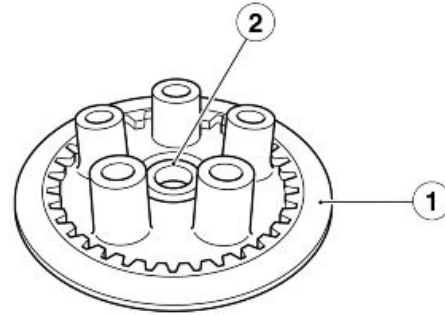

Checking the clutch hub

Check the clutch hub for damage and wear that may result in clutch irregular operation. If necessary, replace the bell.

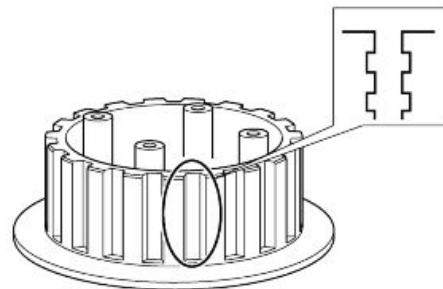

Checking the springs

- Check the springs for damage and, if necessary, replace the them all together.
- Measure the clutch spring length when unloaded; if necessary, replace the springs all together.

**Clutch spring length when unloaded: 46.6 mm
(1.83 in)**

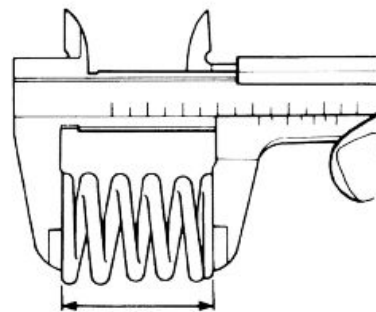

Assembling the clutch

- Fit the shim washer.



- Fit the needle bearing and the spacer.



- Fit the clutch bell.
- Make sure that the oil pump control drive gear of the clutch bell engages correctly with the oil pump driven gear.



- Place the special washer correctly between the clutch bell and the hub.

CAUTION

FIT THE SPECIAL WASHER WITH THE MACHINING FACING THE BELL

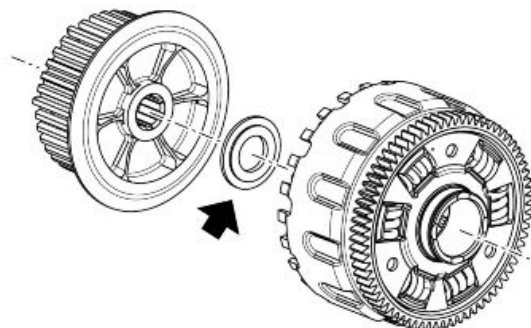

- Place the clutch hub.



- Fit the clutch cover.
- Check that the measurement has not changed compared with the one carried out upon removal; tighten the clutch nut afterwards. If it has changed, rotate the crankshaft so that the oil pump control drive gear engages correctly with the oil pump driven gear on the clutch bell.



- Fit the washer and a new clutch hub nut.
- Tighten the clutch hub nut using the specific tool.



Specific tooling

9100896 Clutch bell locking tool

- Tighten the nut and proceed to caulk.



- Insert the flat ring (1).
- Insert the cupped ring (2).

CAUTION

BE CAREFUL WITH THE CUPPED RING FITTING SIDE; THE RING CONE SHALL BE DIRECTED TOWARDS THE ENGINE.

- Fit the lathed driven disc (3).
- Fit the nitrided steel disc (4).

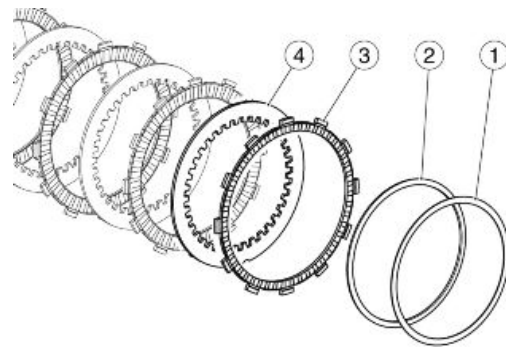

- Fit the clutch discs. Start with the friction material discs and alternate with steel discs.
- Position all friction material discs with their teeth aligned in one of the long slots of the clutch bell.
- Place the control rod.



- Place the pressure plate.



- Fit the clutch springs.
- Fit the screw washers.
- Tighten the six screws operating in stages and diagonally.



- Replace the gasket upon refitting.

Head and timing

Removing the head cover

The operations described below are valid for both heads.

- Undo and remove the four screws and collect the rubber rings.
- Remove the head cover.



Removing the cylinder head

NOTE

THE OPERATIONS DESCRIBED BELOW REFER TO REMOVING ONLY ONE HEAD BUT APPLY TO BOTH HEADS.

- Remove the head cylinder unit.
- Undo and remove the screw on the inlet side.



- Undo and remove the screws on the outlet side.



- Separate the cylinder from the head.
- Collect the washer.



See also

[Removing the cylinder](#)

Cylinder head

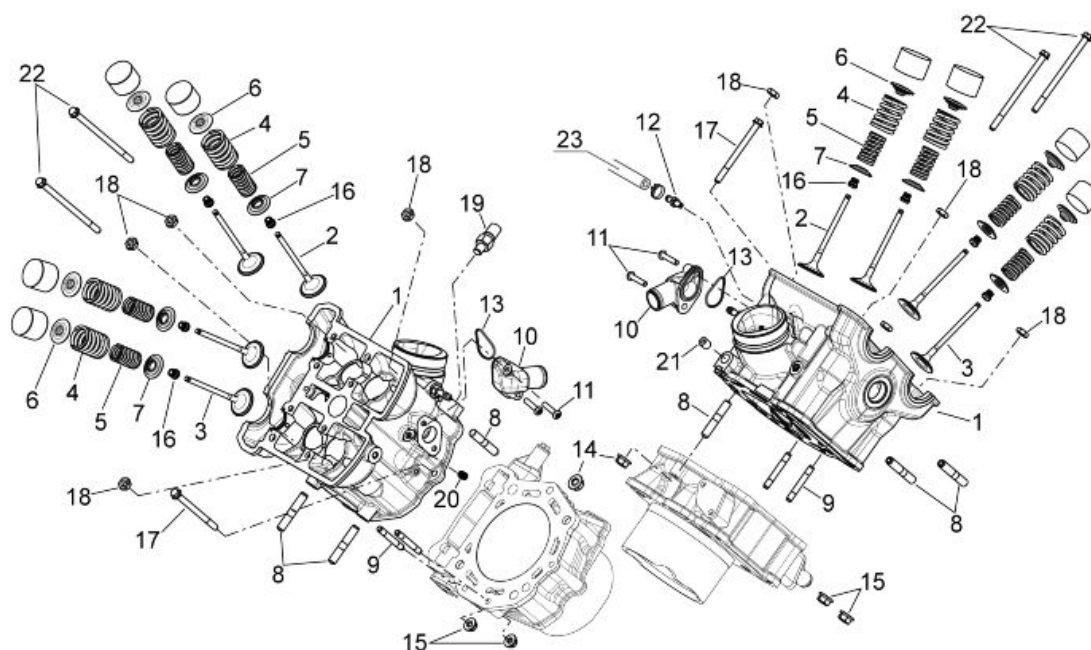

Key:

1. Complete cylinder head
2. Inlet valve
3. Outlet valve
4. External valve spring
5. Internal valve spring
6. Upper cap
7. Lower cap
8. Stud bolt M8X3X46

9. Stud bolt
10. Water pipe fitting
11. TBEI screw
12. Joint
13. O-ring
14. Flanged nut M8X1.25
15. Flanged nut
16. Valve sealing ring
17. TE flanged screw
18. Lock nut M10x1.25
19. Water Temperature Sensor
20. Threaded cap M6X10
21. Threaded cap
22. TE flanged screw
23. To radiator

Removing the overhead camshaft

- Remove the clutch side crankcase half.
- Rotate the crankshaft until the rear cylinder reaches the TDC.



First remove the rear head cover in order to remove the rear head camshafts.

First remove the front head cover in order to remove the front head camshafts.

Mark the head camshafts, the corresponding sprocket wheels and cam caps in order not to interchange them upon refitting.

- Undo and remove the eight cam cap screws working in a diagonal sequence and in stages.

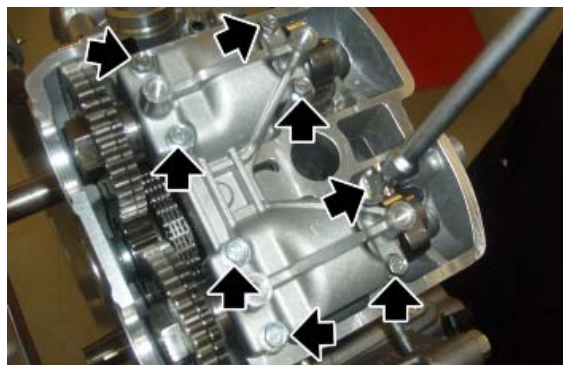

- Remove the cam cap carefully so as not to go through it and damage the seats of the calibrated dowels.
- Remove the camshafts with the gears.



Removing the valves

- When removing the valve, mark the components according to the position and the cylinder they belong to, in order to refit the components to their correct positions.
- Remove the bowl tappets and the adjustment shims using a magnet.



- Compress the valve springs with the specific tightening bow and with the spring compressing tool.

Specific tooling**AP8140179 Valve spring compressor****020721Y Adaptor for valve removal**

- Remove the cotters using a magnet.



- Release the valve springs.
- Remove the valve spring fittings plus the springs.



- Slide off the valves.



Checking the overhead camshaft

Check that the camshaft toothed wheel works properly: if it is damaged or does not move smoothly, replace both the timing chain and the camshaft toothed wheel.

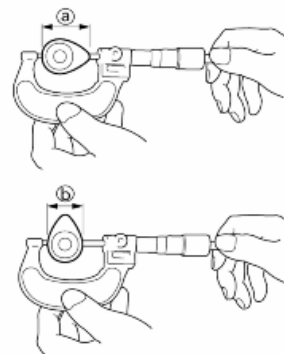

CAMSHAFT LOBES

- Check that they do not show blue colouring, pitting or scratches; otherwise, replace the camshaft and the relevant toothed wheel.
- Use a micrometer to check the sizes (a) and (b) of the camshaft lobes.

Camshaft lobes sizes:

Inlet

- a: 36.28 / 36.32 mm (1.4283 / 1.4299 in); Limit: 36.15 mm (1.4232 in);
- b: 28 mm (1.1023 in);

Outlet

- a: 35.13 / 35.17 mm (1.3831 / 1.3846 in); Limit: 35.00 mm (1.3779 in);
- b: 28 mm (1.1023 in);

- Fasten the camshaft in horizontal position, as shown in the figure, and make it spin to check the eccentricity with a dial gauge; if necessary, replace the component.

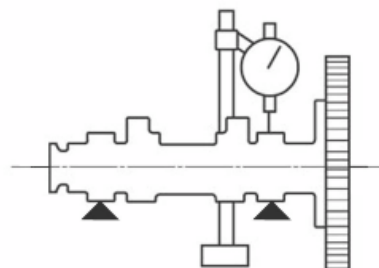

Camshaft eccentricity maximum limit 0.040 mm (0.0016 in)

Valve check

CAUTION

REPLACE THE VALVES ONE AT A TIME. DO NOT MIX THE COMPONENTS. EACH VALVE MUST BE INSERTED IN ITS SEAT, MARKED BEFORE REMOVAL.

CAUTION

THE SEAT (1) ON THE VALVE HEAD CANNOT BE REGROUND. IF REQUIRED, REPLACE THE VALVE.

GRINDING WITH ABRASIVE PASTE IS ALLOWED; VALVE STEM END REGRINDING IS NOT ALLOWED.

Clean off any combustion residues from the valves.

Check the seat (1) on the valve head with a ruler flush.

The surface of the seat must not be concave; replace the valve if necessary.

Check the clearance between the stem and the valve guide:

inlet: **0.013 - 0.040 mm (0.00051 - 0.00157 in);**

limit: 0.080 mm (0.00315 in)

outlet: **0.025 - 0.052 mm (0.00098 - 0.00205 in);**

limit: 0.100 mm (0.00394 in)

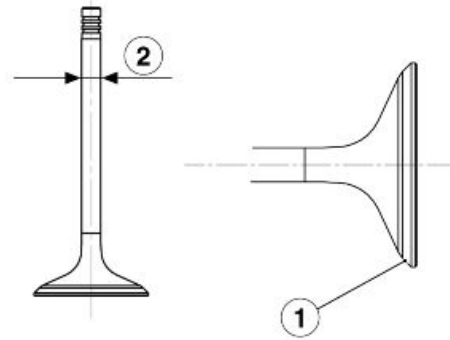

Check the valve eccentricity:

valve stem (3) maximum eccentricity allowed: 0.05 mm (0.00197 in)

valve head (4) maximum eccentricity allowed: 0.05 mm (0.00197 in)

Check that the fixing grooves (5) of the valve cotter pins are in proper conditions.

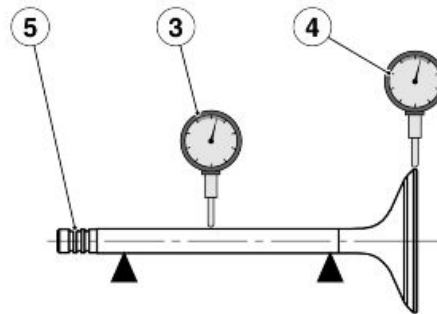

VALVE SPRINGS

Carry out a measurement and a visual inspection of the valve springs for damage, distortion or loss of tension.

Measure the spring length at release position.

Valve springs: **minimum wear limit (6) 42.5 mm (1.673 in).**

Valve springs: **minimum wear limit (7) 38 mm (1.496 in).**

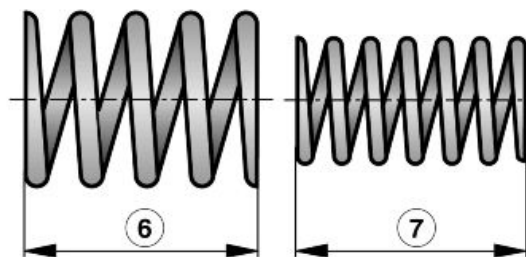

Checking the cylinder head

- Using a round scraper, clean off any carbon deposits in the combustion chamber.

CAUTION

DO NOT USE A POINTED INSTRUMENT TO AVOID DAMAGING OR SCRATCHING THE SPARK PLUG THREADS OR THE VALVE SEATS.

- Check the head for damage or scratches and replace it if necessary.

- Check there are no mineral deposits or rust in the head water cooled jacket; clean off if required.
- Use a checking ruler and a thickness gauge positioned diagonally to the ruler to measure the cylinder head distortion.

Maximum cylinder head distortion: 0.03 mm (0.0012 in)

- Check that the tappet covers and the camshaft toothed wheel cover are not damaged or worn; replace the defective part(s).

Installing the overhead camshaft

The camshaft refitting procedure is described in the "Timing" section.

See also

[Timing](#)

Timing

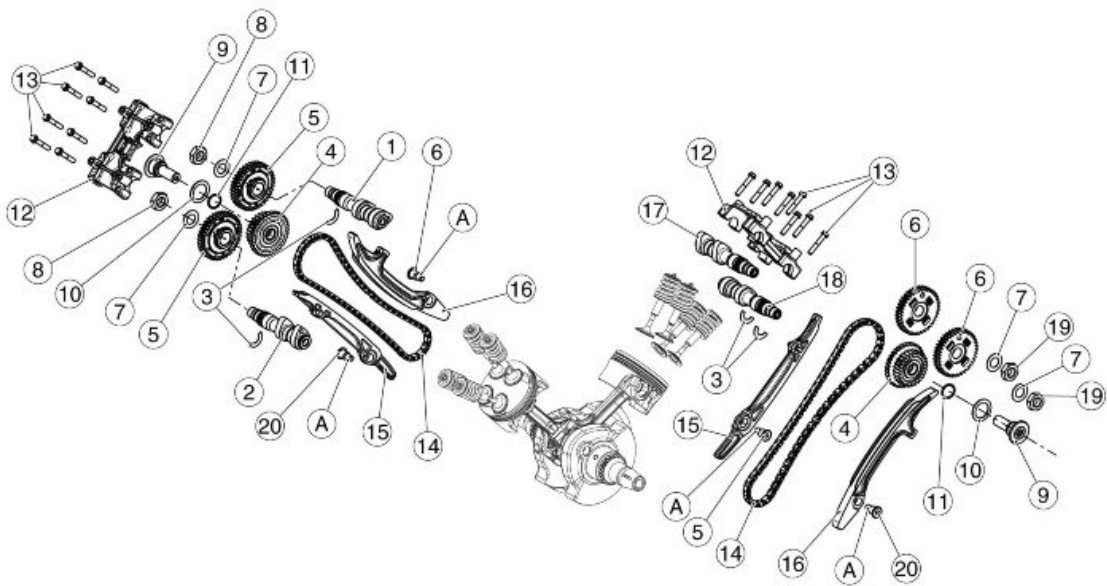

Key:

1. Camshaft - front inlet
2. Camshaft - front outlet
3. Axial restraint
4. Complete timing system gear
5. Complete front timing system gear
6. Complete rear timing system gear

7. Shim washer
8. Right nut M15x1
9. Special screw
10. Safety washer
11. Sealing ring
12. Camshaft support
13. Torx screw M6X35
14. Timing system chain
15. Chain guide slider
16. Chain tightener rod
17. Camshaft - rear inlet
18. Camshaft - rear outlet
19. Left nut M15x1
20. Spacer screw

Removing the chain tensioner

- Undo and remove the screw and collect the washer and the internal spring.

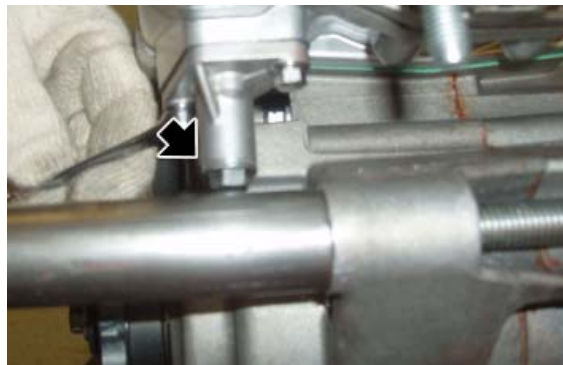

- Undo and remove the two screws.
- Remove the chain tightener and collect the gasket.

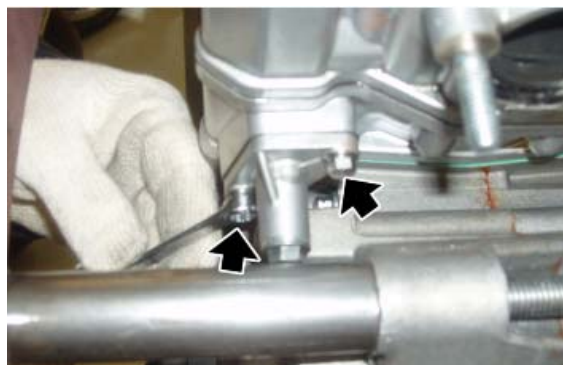

Chain removal

- Remove the chain tensioner.
- Remove the main pinion.
- Remove the movable chain slider and release the fixed chain slider from the clamp.
- Unscrew and remove the pin of the timing chain intermediate gear paying attention not to damage the O-ring.
- Collect the washer.



- Remove the timing chain intermediate gear.



- Slide off the timing chain from the crankshaft.

NOTE

IT IS ADVISABLE TO MARK THE CHAIN IN ORDER TO ENSURE THAT THE INITIAL DIRECTION OF ROTATION IS MAINTAINED.

**See also**

[Removing the chain sliders](#)
[Removing the chain tensioner](#)

Removing the chain sliders

- Remove the chain tensioner and the camshafts from the corresponding head.

FRONT HEAD

- First remove the clutch cover in order to remove the chain sliders from the front head.
- Undo and remove the movable chain tensioner pad screw.
- Slide it off from the head to remove it.



- Undo and remove the fixed chain tensioner pad screw.
- First remove the head in order to remove it.



REAR HEAD

- First remove the flywheel in order to remove the chain sliders from the front head.
- Undo and remove the movable chain tensioner pad screw.
- Slide it off from the head to remove it.



- Undo and remove the fixed chain tensioner pad screw.
- First remove the head in order to remove it.



See also

[Removing the chain tensioner](#)

[Removing the head cover](#)
[Clutch side](#)
[Magneto flywheel removal](#)

Checking the chain

Check the timing chain for damage or stiffness while moving. If required, replace both the timing chain and the camshaft sprocket wheels.

Check the timing chain guide for damage. If necessary, replace the parts.

Installing the chain tensioner

Refit the removed timing system chain tensioner on the cylinder - head:

- Fit the timing chain on the crankshaft and on the intermediate gear.
- Remove the screw and collect the washer and the spring.



- Fit the chain tensioner body on the cylinder and insert a new paper gasket.
- Tighten the two screws to the prescribed torque.



- Insert the spring and tighten the screw together with the washer.



Cam timing

Timing

- Rotate the crankshaft until the front cylinder piston reaches the top dead centre.
- Lock the crankshaft with the specific special tool

Specific tooling

020720Y Timing tool

If necessary, remove the timing system gears from the camshafts:

- Place the camshaft with the timing system gear on a vice and protect the cams of the camshaft adequately.
- Unscrew and remove the nut.



ANTICLOCKWISE NUT FOR BOTH REAR CYLINDER SHAFTS, AN ANTICLOCKWISE ARROW HAS BEEN PUNCHED ON IT.



- Collect the washer.
- Remove the timing system gear from the camshaft.



- Clean gears surfaces (camshaft cone and gear cone) with: "System MC 217 spray metal cleaner".
- Pre-fit the gear on the camshaft, so that it can turn freely.
- Place the two camshafts in the head seats and align the two camshaft holes with the head holes.

- Align the clearance recovery gear to the main timing system gear using the specific tool.



Specific tooling

020718Y Camshaft gear alignment pin

- Using the specific template, check the correct position of the cams.

NOTE

USE OF THE TEMPLATE: THIS TOOL IS PLACED ON THE CAMS WITHOUT THE CAM CAPS, USING THE PROFILE MARKED WITH THE NUMBER OF THE CYLINDER BEING USED, WITH THE MARKINGS FACING THE FLYWHEEL SIDE.

NOTE

THE TEMPLATE IS NOT A TOOL DESIGNED FOR TIMING BUT FOR IDENTIFYING THE CORRECT DIRECTION FOR CAMSHAFT FITTING (THE SHAFTS MAY BE FITTED ROTATED BY 180° WITH REFERENCE TO THE CORRECT POSITION).

Specific tooling

020723Y Template for timing overhead camshafts

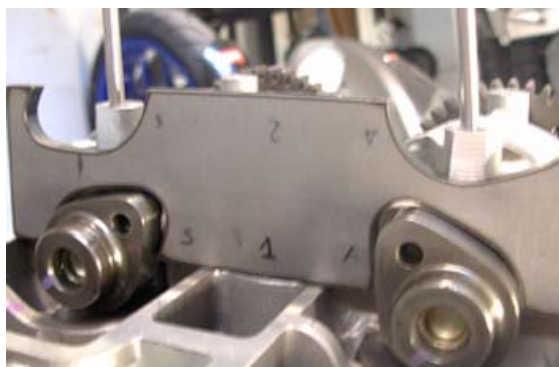

- Place the cam cap.
- Pre-tighten the eight screws in the sequence indicated, to the prescribed torque.
- Tighten the eight screws in the sequence indicated, to the prescribed torque.
- Carry out camshaft timing with the appropriate dowels.

**Specific tooling**

020719Y Timing pin

Locking torques (N*m)

Cam cap/head fixing screws - M6 (16) Pre-tightening: (4.90 - 6.86) Nm ((3.61 - 5.06) lbf ft) Tightening: (9.81 - 12.75) Nm ((7.24 - 9.40) lbf ft)

CAUTION

INSTALL THE CAMSHAFT TIGHTENING NUTS WITH THE MARK FACING UP.

- Pre-tighten the gear nut on the camshaft.



REFIT THE NUT WITH THE MACHINED SURFACE FACING THE GEAR (THE MATERIAL ACRYLONYM SHOULD BE VISIBLE).

Locking torques (N*m)

Nut fixing camshaft gears (pre-tightening) - M15x1 (4) 30 Nm (22.13 lbf ft)

- Remove the camshaft, lock it on a vice with aluminium jaws, then tighten it to the prescribed torque.



DO NOT TIGHTEN THE CAMSHAFT GEAR NUT TO THE ULTIMATE TIGHTENING TORQUE WITH THE SHAFT MOUNTED ON THE CYLINDER. THIS OPERATION WOULD IRRETRIEVABLY DAMAGE THE HEAD .

Locking torques (N*m)

Nut fixing camshaft gears - M15x1 (4) 90 Nm (66.38 lbf ft)

- Remove the gear alignment tool.

Specific tooling

020718Y Camshaft gear alignment pin

- Release the crankshaft from the specific special tool.
- Rotate the crankshaft in the riding direction until the rear cylinder piston reaches the top dead centre.
- Lock the crankshaft with the specific special tool.
- Carry out the timing operations performed for the front cylinder.

Specific tooling

020720Y Timing tool

Cylinder-piston assembly

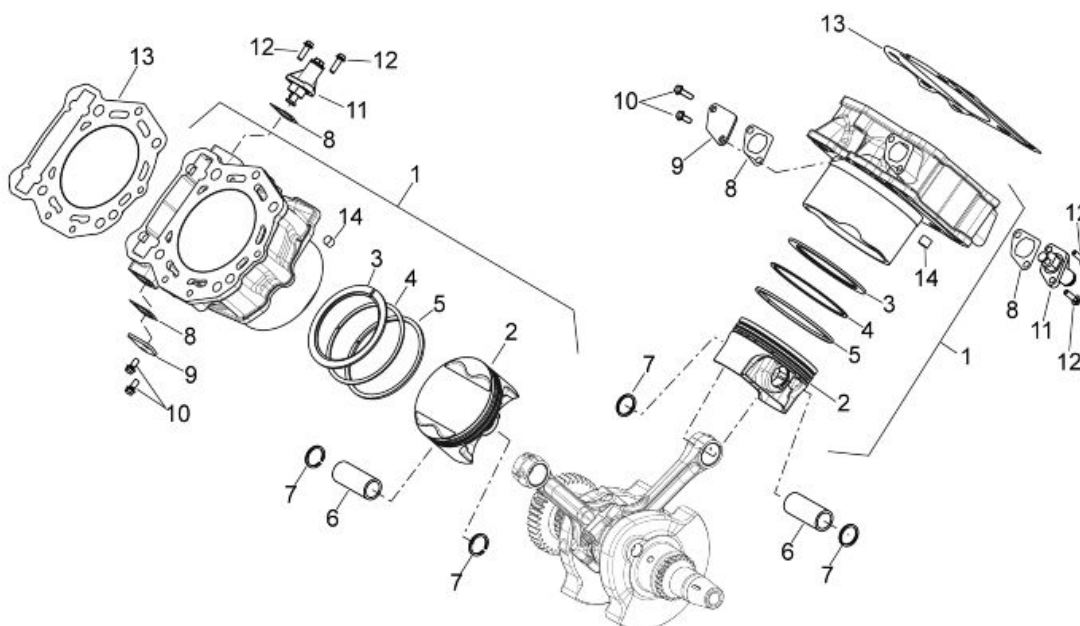

Key:

1. Cylinder - Piston
2. Piston
3. Compression ring
4. Oil scraper ring
5. Oil scraper ring
6. Pin
7. Pin stop ring
8. Gasket
9. Plate
10. TE flanged screw
11. Complete chain tensioner
12. TE flanged screw
13. Head-cylinder gasket
14. 11.8X10 Pin

Removing the cylinder

- Remove the timing chain.
- Undo and remove the two head fixing screws located inside the timing chain compartment.



- Undo and remove the external screw.



- Unscrew and remove the four nuts, working in a diagonal sequence and in stages.
- Slide off the head-cylinder unit from the stud bolts.
- Remove the three fixing screws of the cylinder head to the discharge and intake sides.

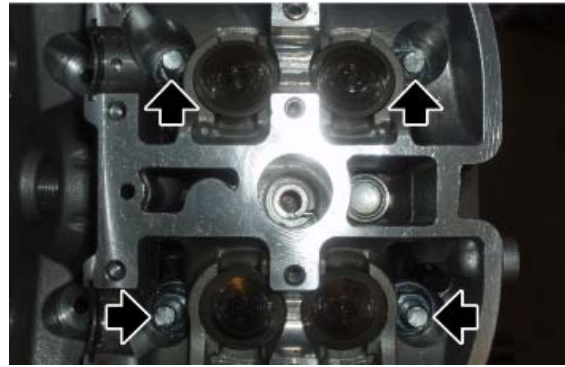

- Remove the gasket between the cylinder and the crankcase.



See also

[Chain removal](#)

Disassembling the piston

- Remove the head and cylinder.
- Take out the pin locking ring.



- Lock the connecting rod using the specific tool.
- Slide off the pin and remove the piston.



Specific tooling

020716Y Connecting rod locking

- Lock the connecting rod using circlips.



FOR SAFETY REASONS COVER THE CRANKCASE WITH A CLEAN CLOTH SO THAT THE SEEGER RINGS DO NOT FALL INTO THE CRANKCASE.



- Remove the top ring, the intermediate ring and the three oil scraper rings.





See also

[Removing the cylinder head](#)
[Removing the cylinder](#)

Checking the cylinder

- All seal surfaces must be clean and flat.
- Make sure all threads are in proper conditions.
- Check cylinder sliding surface for signs of friction and scratches. Also check the seal surfaces for damages.

CAUTION

IF THE GROOVES ON THE CYLINDER LINER ARE EVIDENT, REPLACE THE CYLINDER AND THE PISTON.

- Clean off lime scales on the cylinder cooling slots.
- Measure the cylinder bore at a distance of 10 - 43 - 90 mm (0.39 - 1.69 - 3.54 in) from the head coupling surface; the highest value should be considered to estimate wear limits.

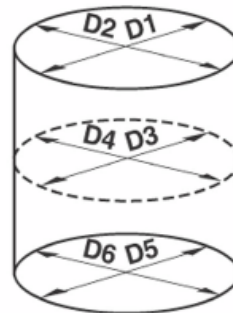

Cylinder bore "C": 92.000 mm (3.6220 - in) C= D1 or D2 max

Cylindricity tolerance: 0.020 mm (0.00079 in)

Replace the cylinder, the piston and the piston ring all together if not complying with specifications.

Checking the piston

- Measure the piston skirt diameter "P" with a micrometer (a=10 mm (0.39 in) from the piston lower border).
- Calculate the clearance between piston and cylinder as follows:

Piston - cylinder clearance $C = C - P$

Piston - cylinder clearance: 0.050 - 0.064 mm (0.00197 - 0.00252 in) Limit: 0.100 mm (0.00039 in)

- Replace the cylinder, the piston and the piston ring all together if not complying with specifications.

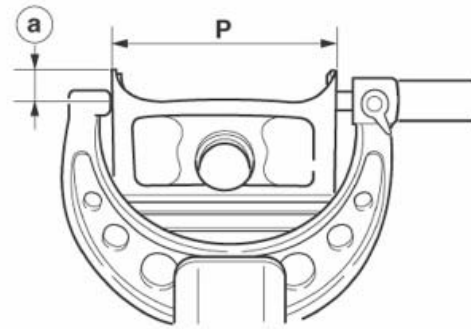

PISTON RINGS

- Clean off any carbon deposits from the grooves in the piston rings and from the rings themselves.
- Measure the piston ring side clearance and replace the piston and the piston rings all together if not complying with specifications.

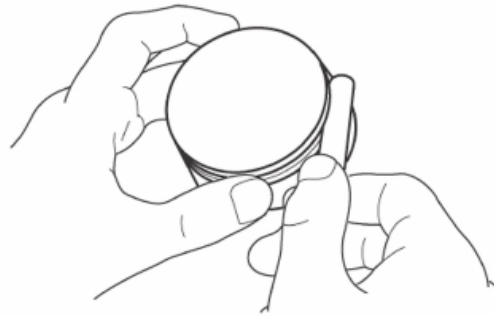

Piston ring side clearance:

Top ring (1st slot): 0.030 - 0.065 mm (0.0012 - 0.0026 in)

Intermediate ring (2nd slot): 0.020 - 0.055 mm (0.0008 - 0.0022 in)

Oil scraper ring (3rd slot): 0.010 - 0.045 mm (0.0004 - 0.0018 in)

- Fit the piston ring to the cylinder.
- Level the installed piston ring with the piston crown.
- Measure piston ring port and replace it if not complying with specifications.

CAUTION

IT IS NOT POSSIBLE TO MEASURE THE GAP OF THE OIL SCRAPER RING END: IF CLEARANCE IS EXCESSIVE, REPLACE THE THREE PISTON RINGS.

Piston ring end gap:

Top ring: 0.25 - 0.40 mm (0.0079 - 0.0157 in)

Intermediate ring: 0.35 - 0.55 mm (0.0138 - 0.0216 in)

Oil scraper ring: 0.20 - 0.70 mm (0.0079 - 0.0276 in)

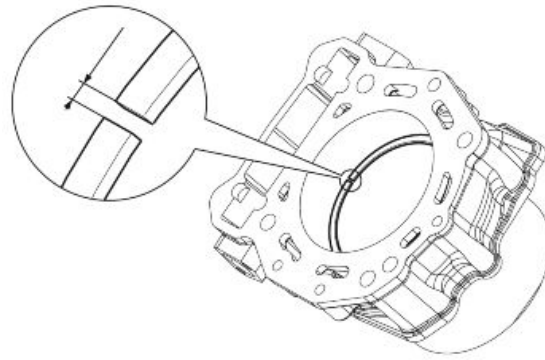

PIN

- Clean off combustion residues from the piston crown and from the area above the top ring.
- Check for cracks on the piston and for compression on the piston sliding surface (seizing); Replace the piston if required.

CAUTION

SMALL STRIATIONS ON THE PISTON LINER ARE ADMISSIBLE.

- Measure the pin outside diameter (a) and if not complying with specifications, replace the pin.

Pin outside diameter: 22.00 - 21.97 mm (0.8661 - 0.8650 in) Limit: 21.96 mm (0.8646 in)

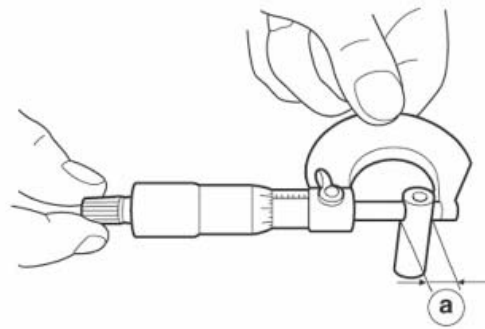

- Measure the pin housing diameter (b) and replace the piston if not complying with specifications.

Pin housing diameter (b): 22.010 - 22.015 mm (0.8665 - 0.8667 in)

- Calculate the clearance between pin and pin hole and, if not complying with specifications, replace both pin and piston.

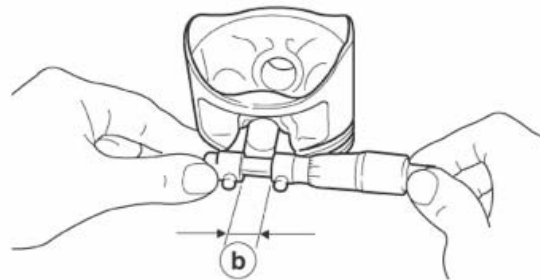

Pin - piston clearance: C = b - a

0.010 - 0.045 mm (0.0004 - 0.0018 in)

Limit: 0.060 mm (0.0024 in)

CYLINDER - PISTON COUPLING

Specification	Desc./Quantity
Piston - cylinder coupling Type A	Cylinder: 91.990 - 91.977 mm (3.6216 - 3.6219 in)

Specification	Desc./Quantity
Piston - cylinder coupling Type B	Piston: 91.933 - 91.940 mm (3.6217 - 3.6197 in) Cylinder: 91.997 - 92.004 mm (3.6219 - 3.6222 in) Piston: 91.940 - 91.947 mm (3.6197 - 3.6199 in)
Piston - cylinder coupling Type C	Cylinder: 92.004 - 92.011 mm (3.6222 - 3.6225 in) Piston: 91.947 - 91.954 mm (3.6199 - 3.6202 in)
Piston - cylinder coupling Type D	Cylinder: 92.011 - 92.018 mm (3.6225 - 3.6227 in) Piston: 91.954 - 91.961 mm (3.6202 - 3.6205 in)
Fitting clearance	0.050 - 0.064 mm (0.00197 - 0.00252 in)

Fitting the piston

Inside the piston there is a stamped arrow that indicates the exhaust side.

- To refit the sealing rings on the piston, position the arrow stamped on the piston external surface facing the operator.

The piston rings are all different and are fitted with the "N" mark facing up.

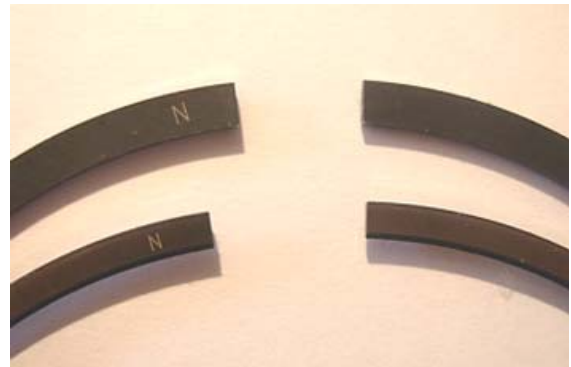

- Fit the oil scraper ring on the piston, with its opening facing the exhaust side.



- Fit the remaining sealing rings on the piston with a 90° offset one from the other.
- Place a new locking ring on the piston.
- Place the piston on the connecting rod and insert the pin.



Specific tooling

020717Y Piston ring driver

- Place a new locking ring on the piston in order to lock the pin.

Specific tooling

020717Y Piston ring driver

Installing the cylinder

Fit the stud bolts, if previously removed.

CAUTION

THE STUD BOLTS SHOULD BE FITTED SO THAT THEY PROTRUDE. DISTRIBUTE Loctite 270 (high-strength) ON THE THREAD AND SCREW THE STUD BOLT ON THE CRANKCASE UNTIL THEY PROTRUDE BY 137 mm (5.39 in), THEN MAKE SURE THE Loctite HAS SET.

- Insert a new cylinder base gasket, it should be as thick as the gasket previously removed: 0.40 - 0.50 - 0.60 mm (0.0157 - 0.0197 - 0.0236 in).
- The silicone side should be facing the crankcase.



CAUTION

IF THE ORIGINAL GASKET THICKNESS CANNOT BE CHECKED OR SHOULD THE CYLINDER BE REPLACED, REFER TO THE "BASE GASKET SELECTION" SECTION.

- Before fitting the cylinder, place the chain sliders and the timing chain on the crankshaft; fit the timing chain on the crankshaft from the base side.



NOTE

BEFORE FITTING THE CYLINDER, CAREFULLY BLOW AIR INTO THE LUBRICATION DUCT AND LUBRICATE THE CYLINDER LINER.

- Insert the cylinder-head unit on the stud bolts.
- Working in a diagonal sequence and in stages, screw the four nuts once the stud bolt threads have been greased.

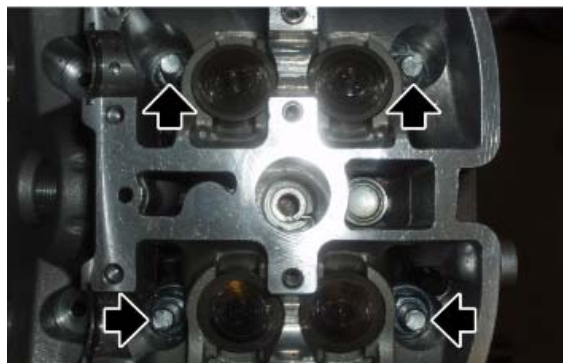

-
- Screw the screw located outside the cylinder.



-
- Tighten the three screws on the intake and discharge sides.
 - Screw the two head fixing screws located inside the timing chain compartment.



-
- Check that the intermediate gear pin lubrication holes are clean.



-
- With a hook, hold the timing chain.
 - Fit the timing chain on the intermediate gear.
 - Slide in the pin together with a new O-Ring and a washer.



- Check that the axial clearance between the pin and the gear is between 0.30 and 0.60 mm (0.0118 - 0.0236 in).

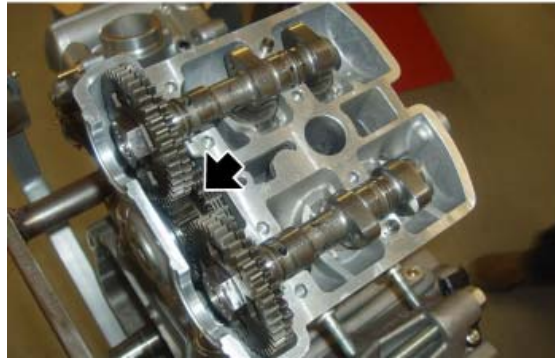

- Tighten the intermediate gear pin once Loctite residues are thoroughly removed and a high-strength threadlock is applied on the thread.
- Make sure that both timing chain sliders are correctly fitted.
- Refit the overhead camshafts following the procedure described in the "Timing" section.



See also

[Selecting the base gasket](#)

Selecting the base gasket

- Place the specific special tool on the piston, which should have sealing rings and be fitted on the connecting rod.
- Lock the special tool with the clamp.

Specific tooling

AP8140302 tool for sealing ring fitting



- Temporarily, fit the piston to the cylinder, without base or head gasket.
- Remove the clamp from the sealing ring locking tool.
- Remove the special tool for locking the connecting rod.



- Fit a dial gauge on the specific tool.
- Set the dial gauge to zero on a reference surface with a medium preload, e.g. 5 mm (0.2 in). Keeping the zero setting, fit the tool on the cylinder and lock it with two nuts (10 Nm - 7.38 lb ft) as shown in the figure.



Specific tooling

020714Y Comparator support

- Rotate the crankshaft up to the TDC (the reversal point of the dial gauge rotation).
- Lock the crankshaft at TDC using the specific tool.
- Calculate the difference between the two measurements: using the chart below, identify the thickness of the cylinder base gasket to be used upon refitting. By correctly identifying the cylinder base gasket thickness, an adequate compression ratio can be maintained
- Remove the specific tool and the cylinder.



Specific tooling

020720Y Timing tool

BASE GASKET

Specification	Desc./Quantity
Measured protrusion -0.10 / + 0.0 mm (- 0.0039 / 0.0000 in)	Gasket 0.4 mm (0.0157 in)
Measured protrusion 0.05 / 0.10 mm (0.0020 / 0.0039 in)	Gasket 0.5 mm (0.0197 in)
Measured protrusion 0.15 / 0.30 mm (0.0059 / 0.0118 in)	Gasket 0.6 mm (0.0236 in)

Installing the cylinder head

- Place the fixed chain tensioner slider on the cylinder timing chain compartment, opposite to the chain tensioner.



- Fit a new gasket between the cylinder and the head.
- Couple the cylinder and the head.



- Screw without tightening the two screws on the outlet side.



- Screw without tightening the screw on the intake side.
- Tighten the cylinder-head fixing screws to the prescribed torque.
- Place the cylinder-head unit on the crankcase stud bolts.



Installing the head cover

CAUTION

BEFORE REFITTING HEAD COVERS, CLEAN HEAD AND COVER SURFACES CAREFULLY.

- Apply THREEBOND on the head cover perimeter along the gasket housing.



- Apply THREEBOND on the head in the areas indicated in the figure.

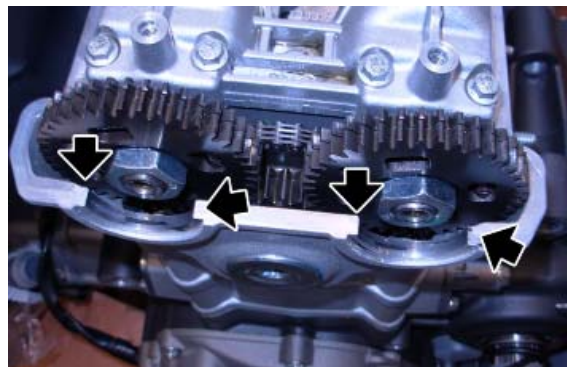

- For the remaining operations, follow the removal operations but in reverse order.

Crankcase - crankshaft

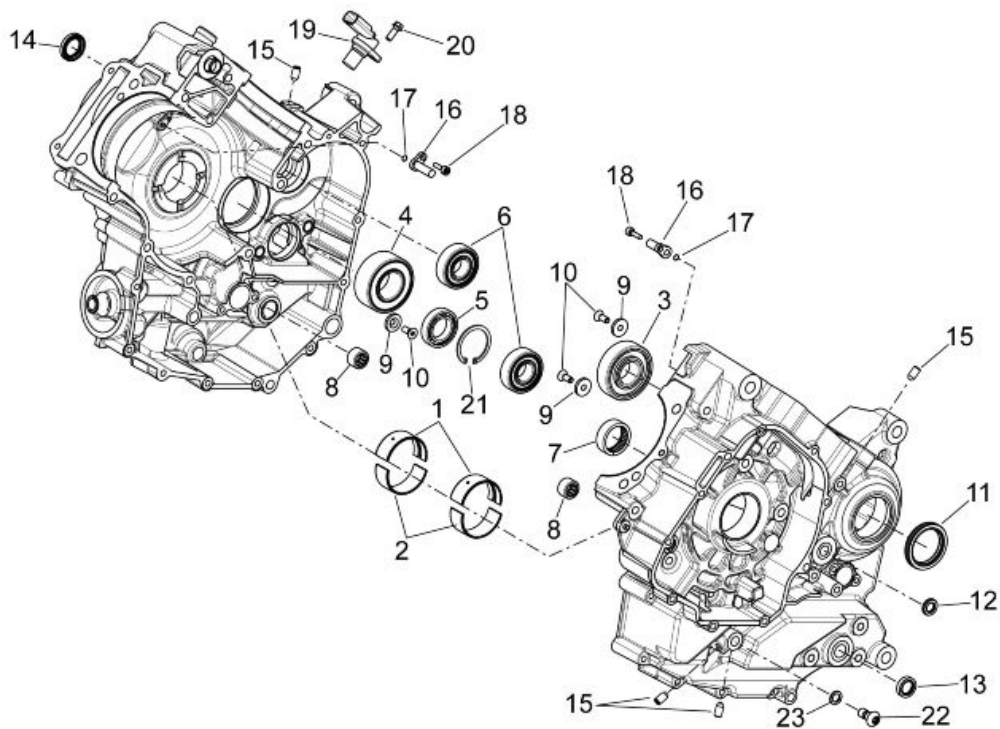

Key:

1. Upper bushing

2. Lower bushing
3. Ball bearing 25x62x17
4. Ball bearing 30x62x23.8
5. Ball bearing 25x42x9
6. Ball bearing 20x47x14
7. Roller casing 30x37x12
8. Roller casing
9. Washer
10. TSPEI screw M6x12
11. Sealing ring
12. Sealing ring 8x16x7
13. Sealing ring 14x22x5
14. Sealing ring 20x30x5
15. Threaded cap
16. Oil spraying pipe
17. OR sealing ring
18. TCEI screw M5X16
19. Timing sensor
20. TE flanged screw
21. Seeger ring for hole
22. Special screw
23. Washer

Splitting the crankcase halves

- Fit the special tool by fixing the four fixing screws steadfastly on the crankcase.
- Using the special tool, unscrew and remove the crankshaft locking nut and collect the washer.

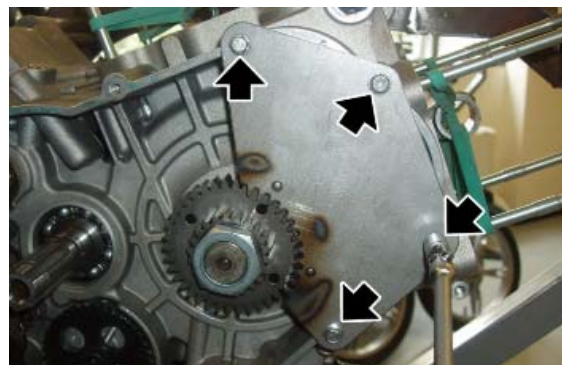

Specific tooling

020711Y Engine pinion locking



- Using a commercial available extractor, remove the crankshaft gear.



- Remove the gear control rod and collect the washer.

- Undo and remove the screw fixing the speed sensor.
- Carefully remove the speed sensor.



- Heat the screws of the gear selector supporting plate.



- Undo and remove the three screws fixing the gear selector plate.



- Remove the plate together with the selector



- Undo and remove the two screws fixing the neutral sensor.



- Remove the neutral sensor.



- Collect the sensor contact together with its spring.



- If the pinion has been removed, refit and lock it with a special tool.

Specific tooling

9100896 Clutch bell locking tool



The tone wheel is sealed with Loctite. Heat it with a suitable blower, paying special attention not to reach high temperatures.

- Remove the speed sensor catch with the specific special tool.

Reposition the tone wheel and seal it with high-strength Loctite upon refitting.

Specific tooling

020715Y Tone wheel removal



- Undo and remove the gear selector drum fixing screw.



- Remove the gear selector drum.



- Remove the pinion.



- Slide off the clutch control rod.



- Working on the left side, undo and remove the nine M8 screws fixing the crankcase.

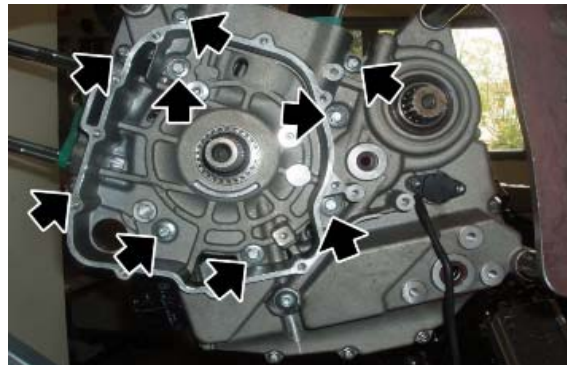

- Working on the left side, undo and remove the nine M6 screws fixing the crankcase.



- Remove the fuel breather clamping plate.

CAUTION

UPON REFITTING THE FUEL BREATHER CLAMPING PLATE, REMEMBER TO INSTALL IT IN THE PINION AREA.

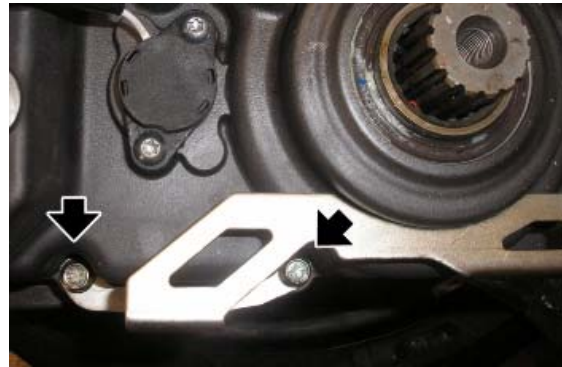

- Rotate the engine and the engine support into horizontal position.



- Undo and remove the pin, tighten it again one turn to allow for crankcase clearance and check sealing.

CAUTION

PAY SPECIAL ATTENTION TO ENGINE AND ENGINE SUPPORT STABILITY AND MAKE SURE THE ENGINE-TO-PLATE FIXING IS RELIABLE.



- Remove the two screws fixing the support.



- Separate the crankcase halves by giving a few taps with a rubber hammer.



- Open the crankcase halves.



- Fix the two screws to the engine support again.



- If necessary, undo and remove the two screws fixing the strum box.
- Remove the strum box.



See also

- [Removing the cylinder](#)
- [Magneto flywheel removal](#)
- [Disassembling the clutch](#)

Removing the crankshaft

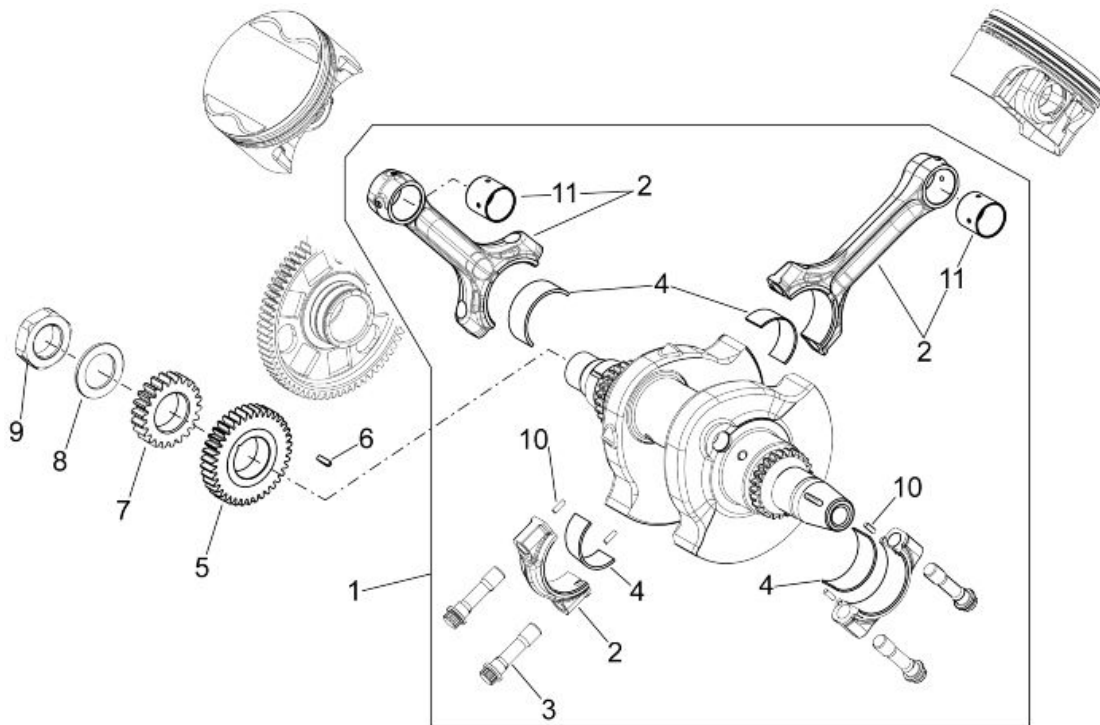

Key:

1. Complete crankshaft
2. Complete connecting rod
3. Connecting rod screw
4. Bushing half-shell
5. Main transmission gear
6. Woodruff Key
7. Water pump gear

8. Plain washer
9. Nut
10. Roller
11. Bushing

- Slide off the crankshaft.



See also

[Splitting the crankcase halves](#)

Inspecting the crankcase halves

BEARINGS AND OIL SEAL CHECK

Thoroughly clean the two sections of the crankcase, the ball bearings, the threads of the crankcase fixing screws and the bearing seats with a non-aggressive solvent. Clean the seal surfaces and check that they are not damaged.

CAUTION

TO AVOID DAMAGING BOTH CRANKCASE HALVES PLACE THEM ON A FLAT SURFACE.

Check that both crankcase halves are not cracked or damaged.

Check that all threads are in proper conditions.

Check that all oil seals remaining in their position are not worn or damaged.

Check all ball bearings for clearance, smoothness and potential distortions.

CAUTION

LUBRICATE BALL BEARINGS WITH ENGINE OIL BEFORE FURTHER CHECKING.

If the internal ring does not rotate smoothly and silently or if there is some noise while it turns, it means that the bearing is faulty and must be replaced.

OIL FILTER AND OIL DELIVERY PIPE CHECK

Check the oil filter for damage. If necessary, replace the part.

Clean the oil net with petrol and inspect the net links for potential damage.



CHECK THE ENGINE OIL FILTER O-RING.

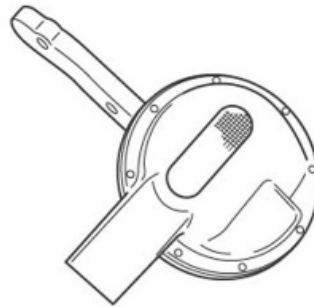

LUBRICATION CHECK

- Working on both crankcase halves, remove and thoroughly clean the nozzle that lubricates the piston crown.

REPLACE THE SPRAY NOZZLE O-RING IF NECESSARY.



- Replace the O-ring on the oil passage duct.



Before refitting



UPON REFITTING THE CRANKSHAFT, GREASE THE SHAFT BUSHING-CONNECTING ROD COUPLING.

Inspecting the crankshaft components

Crankshaft axial clearance check

- The shaft axial clearance on the crankcase should be checked with a comparator mounted on the specific comparator support.
- The clearance should be between 0.1 - 0.4 mm (0.0039 - 0.0157 in).
- If the clearance is beyond tolerance, check the reference surfaces.



Specific tooling

020714Y Comparator support

Assembling the connecting rod

CAUTION

TO FIT THE CONNECTING RODS, CHECK THE COUPLING TYPES INDICATED IN THE "CRANKCASE- CRANKSHAFT CONNECTING ROD" SECTION, IN THE "CHARACTERISTICS" CHAPTER OF THE WORKSHOP MANUAL.

Installing the crankshaft

- Place the left side crankcase half on the engine support adequately.
- Place the crankshaft on the seat of the crankcase half with caution.



Refitting the crankcase halves

- Fit the strum box, if previously removed.
- Tighten the two strum box fixing screws.



- Turn the engine support into horizontal position.
- Place the left crankcase half on the engine support, fitting it on the engine support pins.

CAUTION

PAY SPECIAL ATTENTION TO ENGINE AND ENGINE SUPPORT STABILITY AND MAKE SURE THE ENGINE-TO-PLATE FIXING IS RELIABLE.

- Fit the complete transmission gears unit.
- Apply black sealing paste (Threebond) on the left crankcase half.

CAUTION



BE CAREFUL NOT TO APPLY THREEBOND IN EXCESS AS IT MAY BLOCK OIL DUCTS THROUGH THE CRANKCASE HALVES.



- Place the right crankcase half with the aid of a rubber hammer.



- Tighten the two fixing pins.



- Rotate the engine and the engine support into vertical position.

- Working on the left side, place the nine M6 screws fixing the crankcase.



- Working on the left side, place the nine M8 screws fixing the crankcase.
- Tighten all the crankcase fixing screws, both M6 and M8 type.

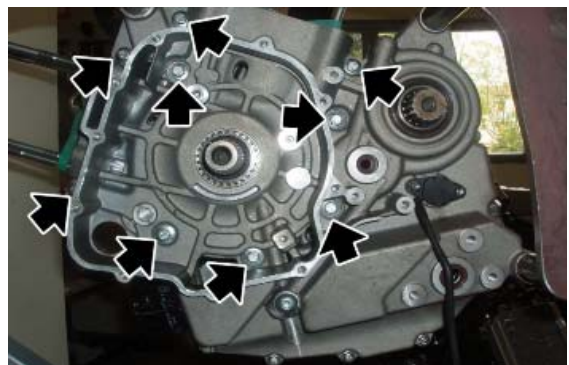

- Slide in the clutch control rod.



- Place the pinion.



- Place the gear selector drum and check that it is correctly timed; thrust the desmo drum axially from the fly-wheel side so that the timing roller protrudes.



- Tighten the gear selector drum fixing screw.



- Position the tone wheel.



- Tighten the tone wheel with the special tool.

Use Loctite medium-strength for sealing.

Specific tooling

020715Y Tone wheel removal



- Tighten the pinion fixing nut using the special tool.

Specific tooling

9100896 Clutch bell locking tool



- Position the sensor contact together with the spring.



- Place the neutral sensor and lubricate its seat to facilitate refitting.



BE CAREFUL NOT TO DAMAGE THE O-RING WHEN INSERTING THE SENSOR IN ITS POSITION.



- Tighten the two screws fixing the neutral sensor.



- Position the plate together with the selector.



- Tighten the three screws fixing the gear selector plate by applying Loctite medium-strength.



- Place the speed sensor with caution.
- Tighten the speed sensor fixing screw.



- Place the transmission control rod with the washer.

- Remove the grease off the primary pinion tapered pins - crankshaft coupling surfaces .
- Position the crankshaft gear.



- Position the washer and the crankshaft lock-nut.



- Fit the special tool and fix it steadfastly to the crankcase by tightening the four fixing screws on the crankcase.
- Tighten the crankshaft gear lock-nut.

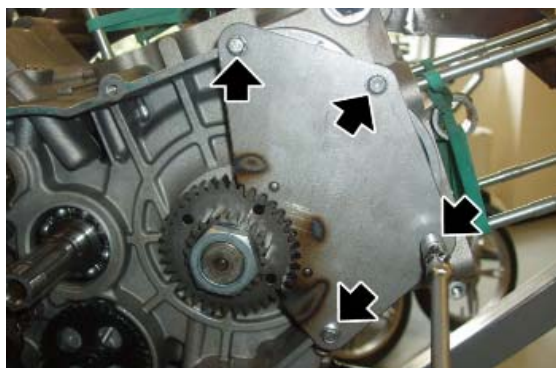

Specific tooling

020711Y Engine pinion locking



Lubrication

Oil pump

Removing

- Lock the pump gear with the commercially available hook spanner and undo the screw; collect the washer.



-
- Collect the shim washer.



-
- Undo and remove the two screws fixing the oil pump.



-
- Remove the entire pump.



Inspection

-
- Undo and remove the two fixing screws.



- Using a thickness gauge check clearance between rotor and stator and replace the rotor / stator unit if required.

clearance between rotor and stator: 0.04 ± 0.10 mm (0.0016 in ± 0.0039 in)



- Slide off the shaft with the cover.



- Collect the lock pin from the shaft.



- Remove the oil pump rotor.



- Remove the oil pump stator.

CAUTION

CHECK THAT THE ROTOR AND STATOR ARE NOT DAMAGED (NO EVIDENT ABRASIONS, SCORES OR ANY OTHER MARKS).

**Installing**

- Follow the oil pump removal operations; carefully align the stator and rotor references upon fitting and check clearance with a thickness gauge.
- If required, replace the stator / rotor unit.

Locking torques (N*m)

Screw fixing oil Pump with Gear - M5 (1) 8 Nm (5.90 lbf ft) (Loctite 270)



INDEX OF TOPICS

POWER SUPPLY

P SUPP

Fuel pump

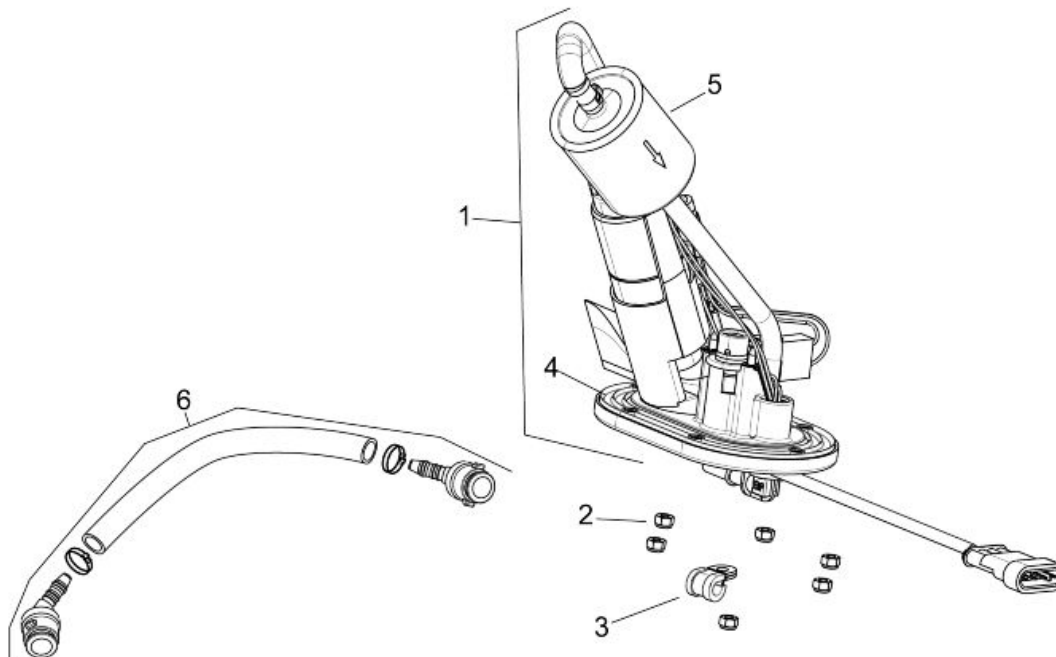
**Key:**

1. Complete fuel pump unit
2. Lower self-locking nut M5
3. Brake pipe plate
4. Flange gasket
5. Fuel filter
6. Fuel delivery pipe

Electrical characteristics:

- Resistance: 0.7 +/- 0.2 Ohm

AXONE: ELECTRICAL ERRORS**Fuel pump relay control P0230**

Example value: short circuit to positive / open circuit, short circuit to negative.

Error cause

- If shorted to positive: excessive voltage has been detected at PIN 62 of the VEHICLE connector.
- If the circuit is open, shorted to negative: voltage equal to zero has been detected at PIN 62 of the VEHICLE connector

Injection

Ride by Wire

RIDE BY WIRE

Operating logic

Those riding motorbikes do not require a specific throttle valve opening from their engines but actually a specific torque. The Ride by Wire system has been so designed that the throttles of the throttle bodies are mechanically isolated from the throttle control; their actuation depends exclusively on 2 electrical motors controlled by the control unit. Therefore, there is a "Throttle map" to which the control unit refers in order to decide the position at which the throttle valves should be and at what speed they should reach the pre-set position. The main parameters which influence the throttle map are:

- Throttle position and opening/closing speed
- Engine rpm
- Inlet pressure read at each inlet manifold
- Rear and front throttle valve position
- Air temperature

The functions required from the Marelli control unit therefore are:

1. Ride by Wire system control (throttle map)
2. Injection/ignition control
3. System safety checks

1 - Ride by Wire system control

THROTTLE GRIP POSITION SENSOR The throttle grip is the part to which the throttle control cables arrive; its task is to translate the rider's power request into an electrical signal to be sent to the electronic control unit. The two throttle cables (opening and closing) actuate on a scroll mounted on a shaft and which is sent back to its home position by a return spring.

On the shaft covers there are 2 double track potentiometers (4 control tracks) by means of which the torque demand is read (and checked).

Marelli 5DM electronic control unit Besides the regular control functions of the injection system, it supervises the throttle bodies: Through the throttle grip position sensor, it reads the torque demand and, through the THROTTLE MAP, it decides the throttle opening and sends the command to the throttle valve control unit. It checks the correct operation of each component (Self-diagnosis), of the system (Safety), and carries out the emergency procedure (Recovery).

EFI throttle control unit The control unit receives the target throttle opening to be carried out and it actuates on the control acting on the throttle body motors.

It checks (through the throttle position sensor signal) that the throttle bodies have reached the target position.

It communicates the position reached to the Marelli control unit. It does not actuate on Safety strategies.

Throttle Body The two throttle bodies are made up of:

- Throttle valve with 2 return springs for the controlled minimum opening position.
- DC electrical motor
- Tinned double throttle position sensors with magnetic control (contactless)

The throttle bodies do not require any maintenance and cannot be overhauled. In case of electric or mechanic malfunction, replace the whole unit.

Pressure sensors The pressure sensors (one per cylinder) are fundamental not only for the injection map at low and stabilised speeds but also for checking the Ride by Wire system: their signal is connected to a TORQUE CHAIN for checking the correct opening of the throttle valves.

Intake air temperature sensor The signal coming from the sensor is used to calculate the estimated torque since the oxygen in the air also depends on its density which varies according to temperature.

2 - Injection/ignition control

Map for injection type (alpha-D)/rpm where:

- alpha is the throttle position
- D is the pressure measured at inlet ducts
- Rpm are the engine revolutions
- At idle and for slow and stabilised speeds D/n
- For medium-high throttle openings alpha/n
- For temporary speed (speed change) alpha/n
- The main parameters that correct the injection map are:
- Engine temperature
- Atmospheric pressure (calculated)
- Lambda probe signal
- Air temperature

3 - System safety checks

The checks are structured in several levels:

- Level 1 - sensor correct operation
- Level 2 - comparison between requested torque and estimated torque generated by the engine
- Level 3 - a microprocessor controls the correct operation of the regular microprocessor

The consequent maintenance operations may be of different gravity according to the level and the defective component:

A the malfunction does not affect riding in safety, the warning light turns on, the word Service is displayed, the signal recovery value considered not reliable is used and the engine works regularly.

B the malfunction may affect riding in safety, the warning light turns on, the message Urgent Service is displayed, the torque demands are not fully activated (reduced torque).

C the malfunction may affect riding in safety, the warning light turns on, the message Urgent Service is displayed, the engine operates in Limp Home function (accelerated idle), the throttles which are at

the position exclusively depending on the springs are not moved. The engine may shut off during the operation if it is running at idle speed and the gear is in neutral.

D the malfunction may affect riding in safety, the warning light turns on, the message Urgent Service is displayed, the engine stops running.

Removing the throttle body

- Remove the filter casing.
- Working on both bodies, undo and remove the four screws and slide off the filter support.

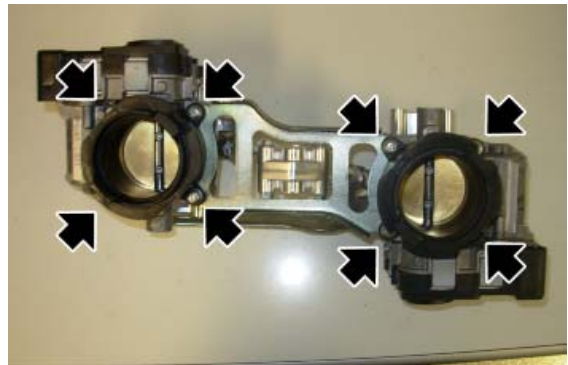

- Remove the upper plate.



- Remove both bodies.

UPON REFITTING , REPLACE THE THROTTLE BODY GASKET WITH A NEW ONE OF THE SAME TYPE.

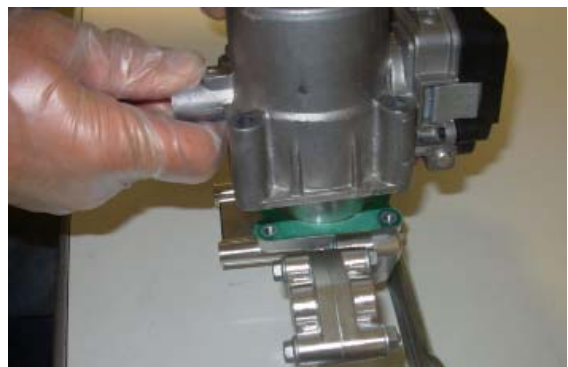

- Working on both bodies, undo and remove the two plate screws.



- Remove the plate.
- Working on both bodies, undo and remove the screw and detach the body.



- Working on the body in question, remove the injector, slide off the clip and the injector itself.

**CAUTION****NEVER UNDO THE SCREWS IN THE FIGURE**



Using axone for injection system

The complete list of all the parameters- device status, errors, etc.- is available at the home page of the website www.serviceaprilia.com in the search section: Axone Parameters.

The same parameters- device status, errors, etc. -are grouped per type of component they refer to in the **Electrical system chapter, Checks and Controls**

INDEX OF TOPICS

SUSPENSIONS

SUSP

Front

Removing the front wheel

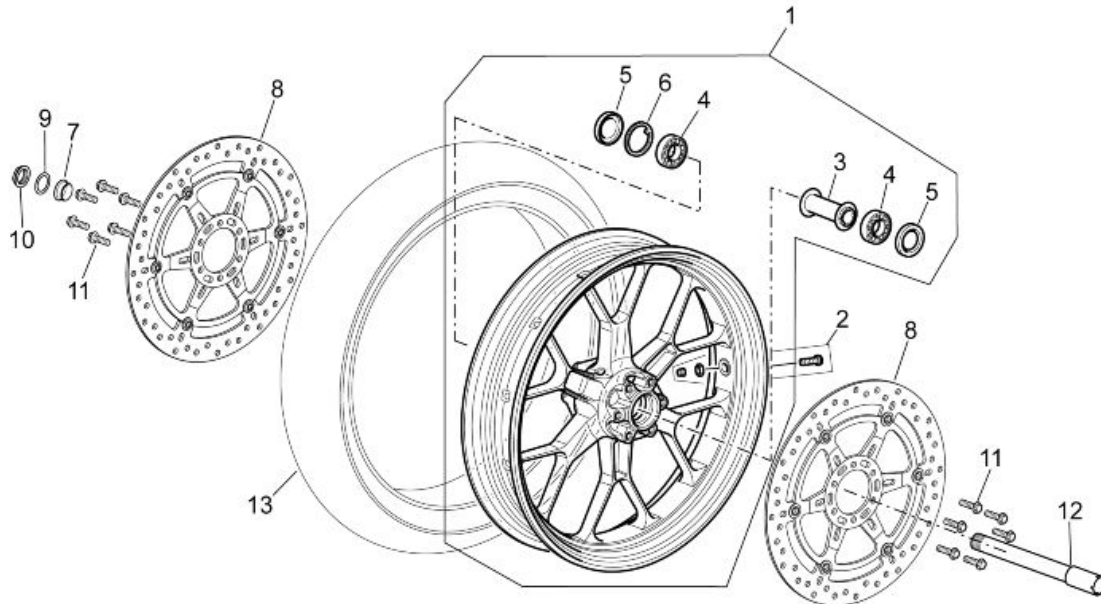
**Key:**

1. Front wheel 3.5"x17"
2. Tubeless valve
3. Internal spacer
4. Bearing
5. Sealing ring 30x47x7
6. Seeger ring
7. Front wheel right external spacer
8. Front brake disc
9. Washer 25.2x36x1
10. Wheel pin nut
11. TE flanged screw M8x20
12. Front wheel pin
13. Front cover 120/70 ZR 17"
 - Hold the scooter front part.

- Undo the screws fixing the front mud-guard and remove it.

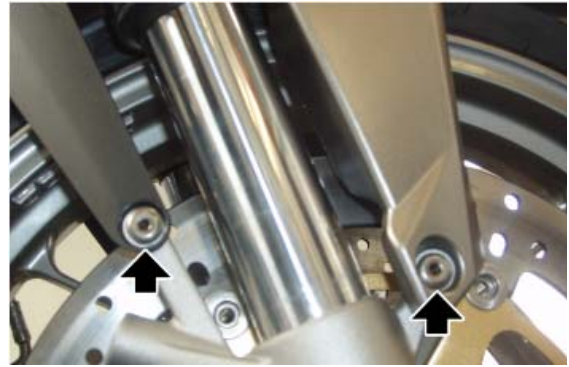

- Undo the screws fixing the front pliers and slide them off the disc.



- Remove the wheel pin fixing nut.
- Collect the sealing washer.



- Loosen the screws on the wheel pin clamps.



- Tap the wheel pin with a rubber hammer so that the holes on the opposite side are exposed.
- Remove the wheel pin by inserting a screwdriver in the holes on the pin.



- During extraction, support the wheel and then remove it.
- Collect the spacer from the front wheel left side.



Checking the front wheel

FRONT WHEEL BEARINGS

Carry out the check with the bearings fitted on the wheel.



CHECK THAT ALL THE PARTS ARE IN GOOD CONDITIONS, ESPECIALLY THOSE MENTIONED BELOW.

ROTATION CHECK

- Manually rotate the inside ring of each bearing. Rotation must be constant, smooth and noiseless.

If one or both bearings do not fall within the control parameters:

- Replace both wheel bearings.

RADIAL AND AXIAL CLEARANCE CHECK

- Check the radial and axial clearance.

Axial clearance: a minimum axial clearance is allowed.

Radial clearance: none.

If one or both bearings do not fall within the control parameters:

- Replace both wheel bearings.



**ALWAYS REPLACE BOTH BEARINGS.
ALWAYS REPLACE THE BEARINGS WITH OTHERS OF THE SAME TYPE.**

GASKETS

- Check that the gaskets are in good conditions; replace them if they show signs of damage or excessive wear.



**ALWAYS REPLACE BOTH GASKETS.
ALWAYS REPLACE THE GASKETS WITH OTHERS OF THE SAME TYPE.**

WHEEL PIN

- Using a dial gauge, check the wheel pin eccentricity. If the eccentricity exceeds the limit value, replace the wheel pin.

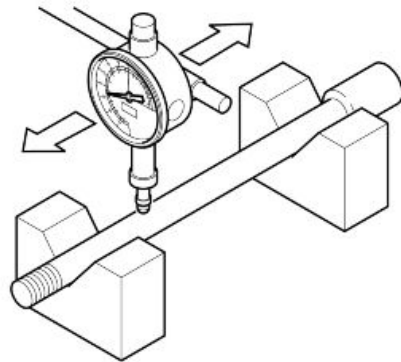

Characteristic

Maximum eccentricity:

0.25 mm (0.0098 in)

- Using a dial gauge, check that the radial (A) and the axial (B) eccentricities of the rim do not exceed the limit value. An excessive eccentricity is usually caused by worn or damaged bearings. Replace the rim if, after replacing the bearings, the value is not within the specified limit.

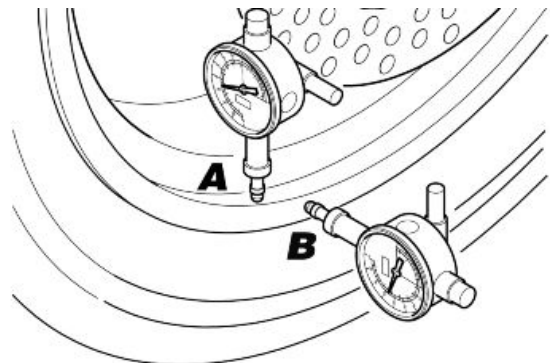

Characteristic

Maximum radial and axial eccentricity:

2 mm (0.0079 in)

Handlebar

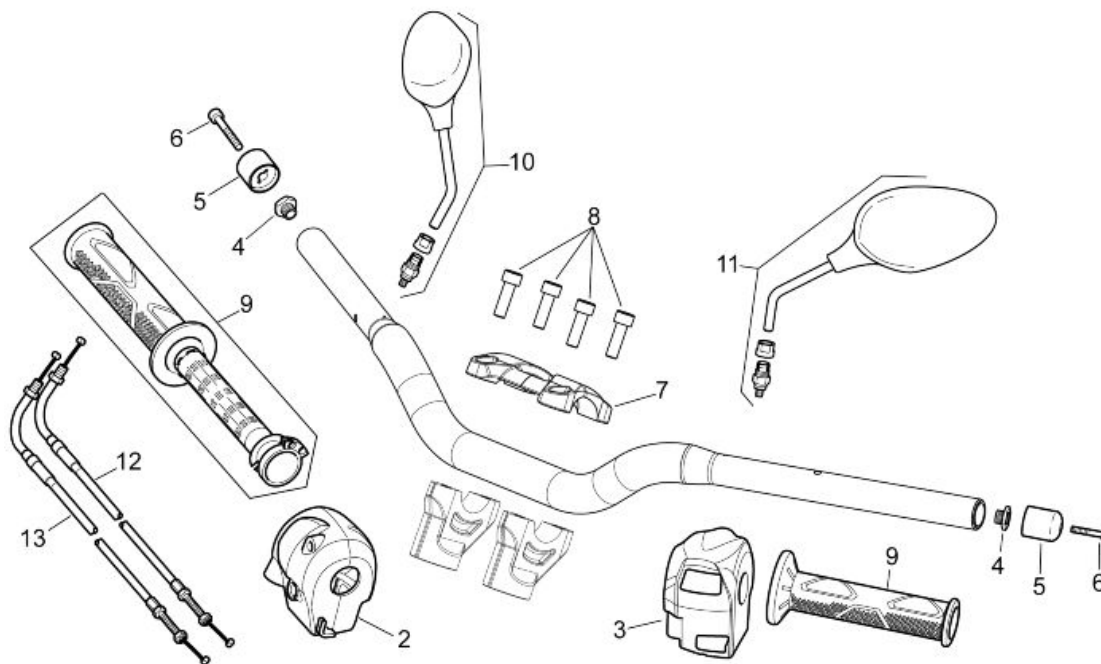
**Key:**

1. Handlebar
2. Right light switch
3. Left light switch
4. Anti-vibration weight terminal
5. Anti-vibration weight
6. TCEI screw M6x40
7. Upper U-bolt
8. Screw M8x25
9. Handgrips
10. Right rear-view mirror
11. Left rear-view mirror
12. Throttle opening cable
13. Throttle closing cable

Front fork

Diagram

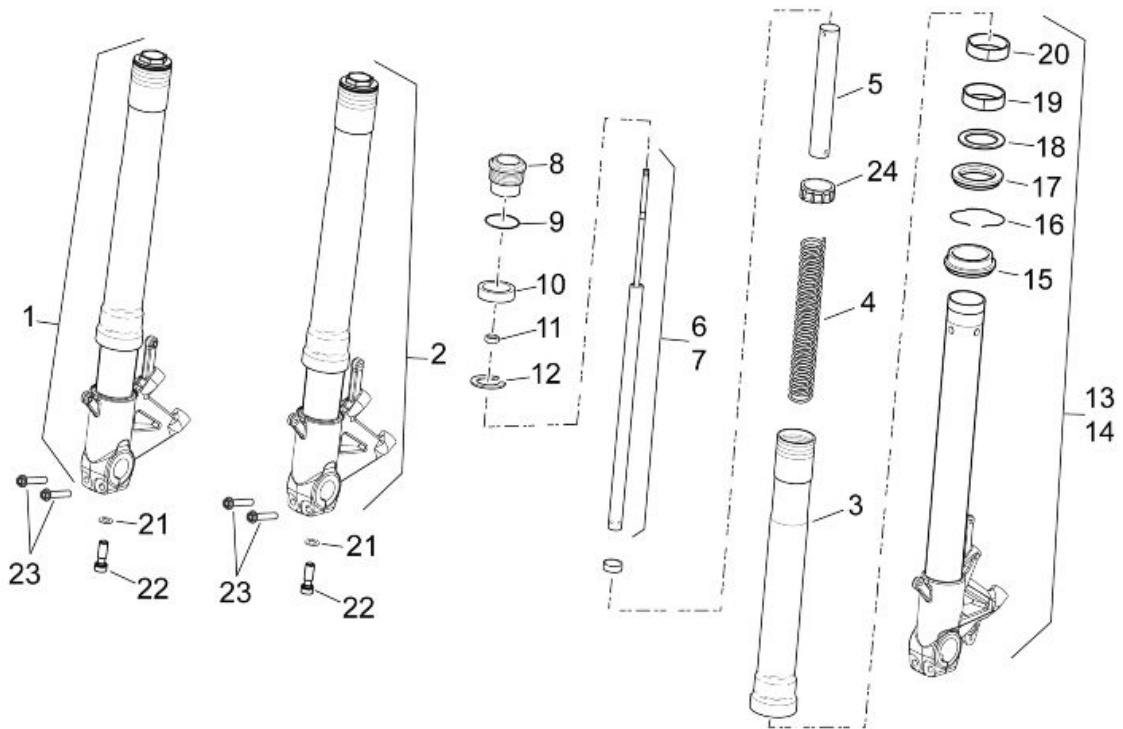

Key:

1. Fork right stem
2. Fork left stem
3. Sleeve
4. Spring
5. Preloading pipe
6. Right pumping member assembly
7. Left pumping member assembly
8. Sleeve cap assembly
9. O-ring
10. Rubber ring
11. Nut
12. Snap ring
13. Stem+ right wheel holder assembly
14. Stem+ left wheel holder assembly
15. Dust guard
16. Seeger ring
17. Oil seal
18. Ring
19. Guide bushing

- 20.Sliding bushing
- 21.Special washer
- 22.Screw M10x1.5
- 23.TE flanged screw M8x40
- 24.Spring Centring

Removing the fork legs

- Remove the front wheel.
- Support the fork stem and loosen the screws on the upper and then the lower plate.
- Remove the fork stem.



Draining oil

NOTE

THE OPERATIONS DESCRIBED BELOW ARE VALID FOR BOTH STEMS.

NOTE

BEFORE CARRYING OUT THE FOLLOWING OPERATIONS GET A CONTAINER WITH SUITABLE CAPACITY TO COLLECT THE OIL.

- Remove the fork.

- Being careful not to damage the fork stem when placing it in a vice, in vertical position, using the appropriate protection.



Specific tooling

AP8140149 Protection for fitting operations

- Unscrew the sleeve cap.



- Drain the oil into a container of suitable capacity to collect fluids.



**DO NOT DISPOSE OF OIL INTO THE ENVIRONMENT.
DISPOSE OF ENGINE OIL STORED IN A SEALED CONTAINER AND TAKE IT TO YOUR SUPPLIER OR TO THE NEAREST USED OIL RECLAMATION FIRM.**



See also

[Removing the fork legs](#)

Disassembling the fork

WARNING

DO NOT INTERCHANGE THE STEMS, THEY HAVE INTERNAL DIFFERENCES. THE LEFT CARTRIDGE (2) HAS A SLOT AT THE BOTTOM, WHILE THE RIGHT ONE (1), HAS A SLOT ON THE UPPER SIDE.

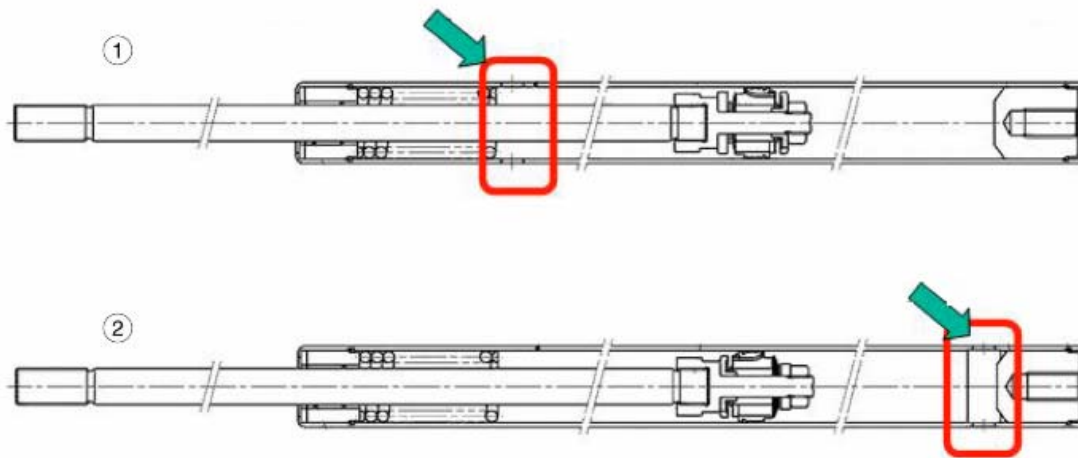

NOTE

THE OPERATIONS DESCRIBED BELOW ARE VALID FOR BOTH STEMS.

- Drain the fork oil.
- Place the fork stem on a work table in upright position.
- Fit the special tool.

Specific tooling

AP8140147 Spacer tool



With the help of a second operator:

- Hold the sleeve cap firmly.
- Push the special tool down.
- Take out the Seeger ring.



With the help of a second operator:

- Insert the special tool between the nut and the preloading pipe.

Specific tooling

AP8140148 Spacer-pumping element separating plate



- Loosen the nut.



- Remove the sleeve cap.



- Slide off the preloading pipe together with the spring centring.



- Be careful not to damage the fork stem when placing it in a vice, in horizontal position, using the appropriate protections.



Specific tooling

AP8140149 Protection for fitting operations

- Unscrew and remove the bottom screw and collect the special washer.



- Slide off the pumping member together with the spring.



- Remove the dust guard using a screwdriver as a lever.



- Remove the Seeger ring from inside the sleeve with the aid of a screwdriver.

CAUTION

DO NOT DAMAGE THE STEM DURING THE OPERATION.



- Slide off the stem forcefully.



- If necessary, remove the sliding bushing, guide bushing, ring, oil seal, Seeger ring and dust guard from the stem.

**See also**

[Draining oil](#)

Checking the components**Stem**

Check the sliding surface for scorings and/or scratches.

These scorings can be eliminated by rubbing them with wet sandpaper (grain 1).

If the scorings are deep, replace the stem.

Use a dial gauge to check that the stem bending is below the limit value.

If over the value, replace the stem.

CAUTION

A BENT STEM SHOULD NEVER BE STRAIGHTENED BECAUSE ITS STRUCTURE WOULD BE WEAKENED AND USING THE VEHICLE MAY BECOME DANGEROUS.

Characteristic

Bending limit:

0.2 mm (0.00787 in)

Sleeve

Check that there are no damages and/or cracks; otherwise, replace it.

Spring

Check that the spring is in good conditions. Check that the spring length is within the limit value.

Replace the spring if its length does not fall within the limit values.

SPRING MINIMUM LENGTH WHEN UNLOADED: 300.8 mm (11.84 in)

Check that the following components are in good conditions:

- sliding bushing;
- guide bushing;

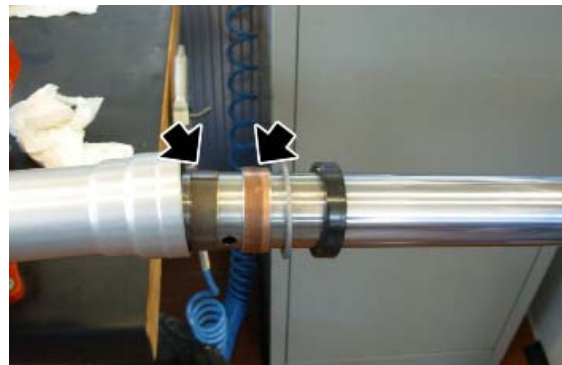

- pumping member.

If there are signs of excessive wear or damage, replace the affected component.

CAUTION

REMOVE ANY IMPURITY IN THE BUSHINGS, TAKING CARE NOT TO SCRATCH THEIR SURFACE.

Replace the following components with new ones:

- oil seal
- dust guard

Reassembling the fork

NOTE

THE OPERATIONS DESCRIBED BELOW ARE VALID FOR BOTH STEMS.

- Fit the dust guard (1), Seeger ring (2), oil seal (3), ring (4), guide bushing (5) and sliding bushing (6) on the stem.

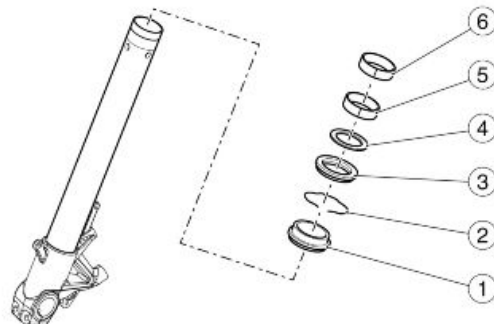

CAUTION

FIT THE GUIDE BUSHING AND THE SLIDING BUSHING WITH CAUTION. GUIDE BUSHING (5) IS THICKER THAN SLIDING BUSHING (6).

- Fit the stem to the sleeve and place the special fitting tool for fitting the D.43 oil seal between the Seeger ring and the oil seal.

Specific tooling

AP8140189 Oil seal fitting tool for Ø 43 mm (1.69 in) holes



- Push the oil seal fitting special tool hard, applied towards the sleeve with the aid of the specific weight.

Specific tooling

AP8140146 Weight



- Fit the Seeger ring on the sleeve seat.

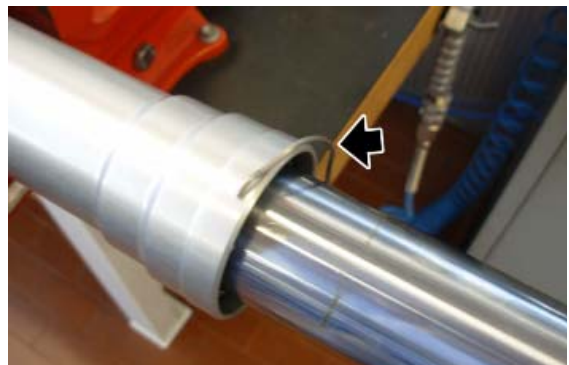

- Fit the dust guard.

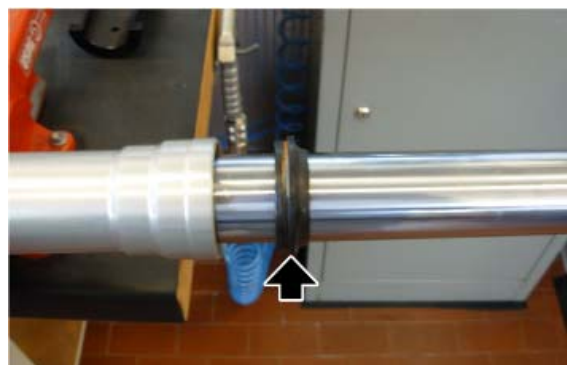

- Screw the specific perforated rod on the pumping member threaded rod.

Specific tooling

AP8140150 Perforated rod for pumping member air bleed



- Fit the centring plate.
- Fit the pumping member together with the centring plate in the sleeve.
- Insert the special washer in the screw.
- Tighten the screw to the prescribed torque.



UPON REFITTING, REPLACE THE SAFETY WASHER WITH A NEW ONE.

Locking torques (N*m)

Screw fixing the stem in wheel carrier - M10x1.5 (2) 20 Nm (14.75 lbf ft)

Filling oil

NOTE

THE OPERATIONS DESCRIBED BELOW ARE VALID FOR BOTH STEMS.

- Place the fork stem on a work table in upright position.
- Fill the sleeve with the adequate quality and type of oil indicated on the recommended products table.

WARNING

MOVE THE PUMPING ELEMENT SEVERAL TIMES UNTIL AIR BUBBLES ARE SEEN ON THE OIL SURFACE.



THE SLEEVE MUST BE PERFECTLY VERTICAL FOR A CORRECT OIL LEVEL MEASUREMENT. THE OIL LEVEL MUST BE THE SAME IN BOTH STEMS.

Characteristic

Fork oil quantity (for each stem):

535 cm³ (32.65 cu.in)

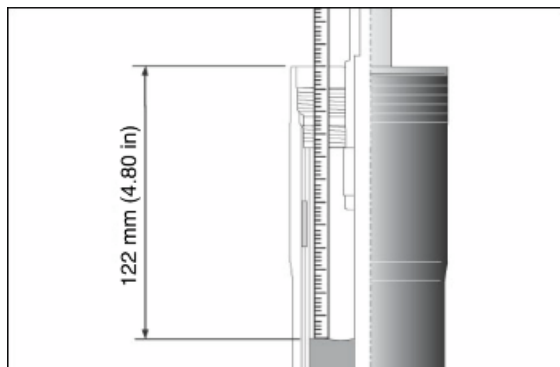

Oil level (from sleeve rim, without the spring and with pumping member fully down)

122 mm (4.80 in).

- Fit the spring.



- Fit the preloading pipe together with the spring centring.



- Fit the special tool.

Specific tooling

AP8140147 Spacer tool



- With the aid of a second operator, hold the pumping member rod firmly, lower the spacer retention tool, insert the stop ring and the plate separating the spacer-pumping member between the ring and the nut.

Specific tooling

AP8140148 Spacer-pumping element separating plate



- Insert the sleeve cap and screw the nut.



- Being careful not to damage the fork stem when placing it in a vice, in vertical position, using the appropriate protection.



Specific tooling

AP8140149 Protection for fitting operations

- Tighten the sleeve cap.



Steering bearing

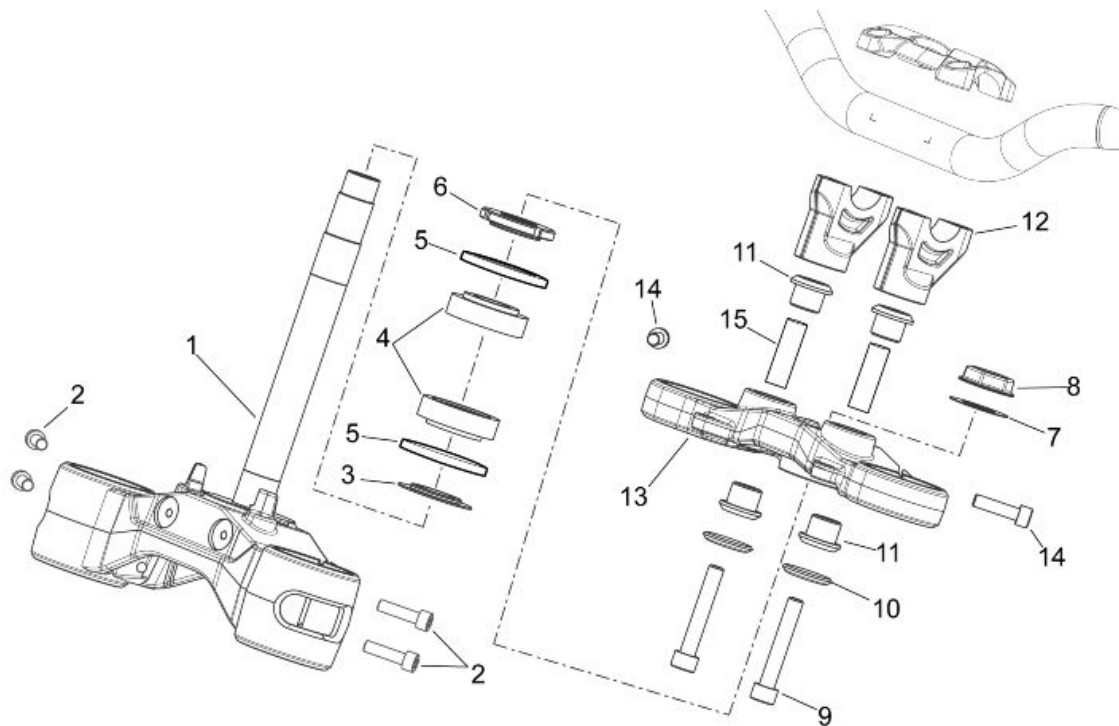

Key:

1. Fork lower plate
2. Screw M8x30
3. Washer
4. Roller bearing
5. Sealing ring
6. Ring nut
7. Headstock cap washer
8. Headstock cap
9. TCEI screw M10x60
10. Cap
11. Rubber ring
12. Lower U-bolt
13. Fork upper plate
14. Screw M8x30
15. Spacer 10.1x14.1x38

Adjusting play

- Place the vehicle so that the front wheel is off the ground.
- Shake the fork in the riding direction.

- Adjust if clearance is detected.
- Unscrew and remove the four screws of the fixing U-bolt.
- Remove the U-bolt.
- Remove the handlebar and place it paying attention that oil in the clutch and front brake tanks does not spill out.



- Unscrew and remove the top bolt on the headstock and collect the washer.



- Operating from both sides, loosen the screws fixing the fork stems to the upper plate.



- Undo and remove the two screws fixing the instrument panel support to the fork upper plate.

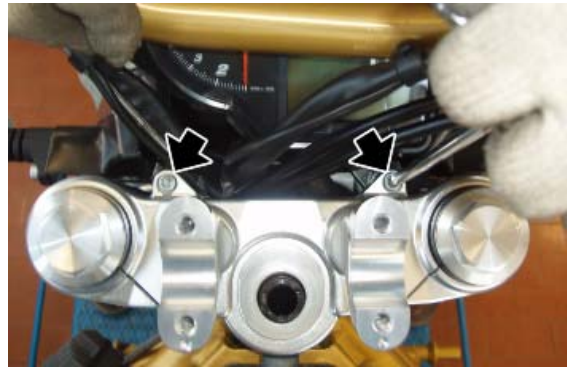

- Slide off the fork upper plate by moving it towards the instrument panel.



- Adjust the steering bearings preloading by tightening the ring nut with the specific tool.



When refitting the U-bolt, position the two references facing the front part of the vehicle.



Rear

Removing the rear wheel

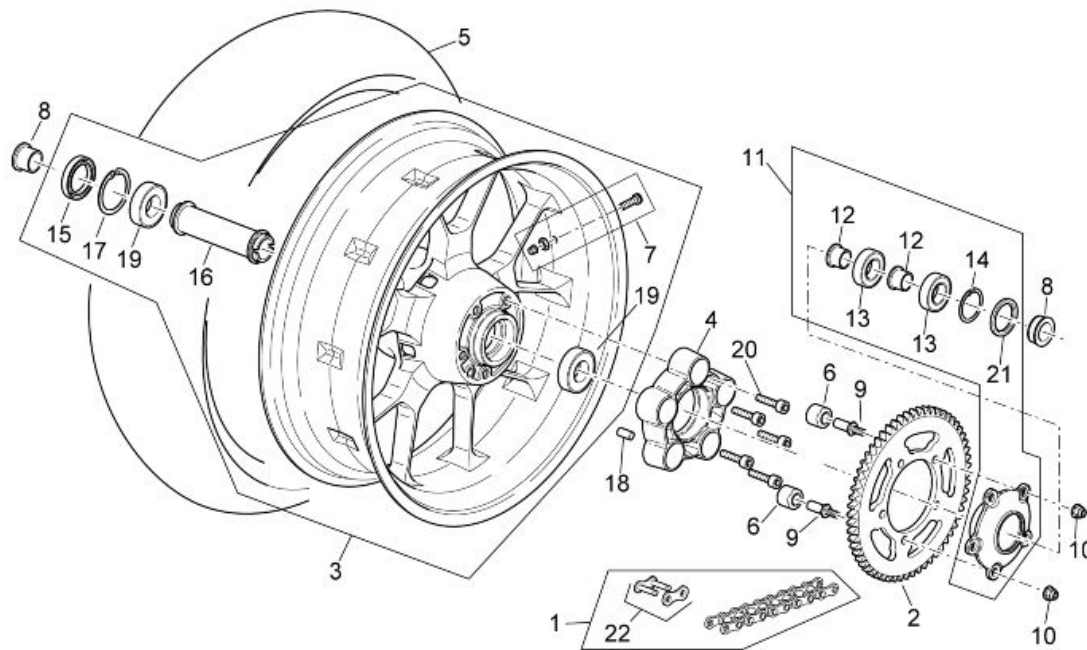

Key:

1. Chain with master link
2. Crown
3. Rear wheel 6"x17"
4. Rear wheel anti-vibration buffer
5. Rear cover 180/55 ZR 17"
6. Anti-vibration rubber buffer
7. Tubeless valve
8. Rear wheel spacer
9. Pin
10. Lower self-locking nut M10
11. Sprocket carrier assembly
12. Anti-vibration buffer spacer
13. Bearing 30x55x13
14. Seeger ring for hole
15. Sealing ring 30x52x7
16. Internal spacer
17. Seeger ring
18. 10x20 Pin
19. Bearing

20.TCEI screw M10x30

21.Sealing ring 38x52x7

22.Master link

- Place the vehicle on its rear service stand.
- In order to work faster, remove that the chain cover.
- Fully slacken the gearing chain tension.
- Make the wheel move forward and release the gearing chain from the crown gear.



- Unscrew and remove the nut on the wheel pin.
- Collect the thrust washer and the right chain tensioner slider.



- Working on the right side, hit the wheel pin lightly so as to take out the head from its housing.
- Working on the left side, slide off the wheel pin together with the chain guide slider.
- Remove the wheel by freeing the disc from the brake calliper.



- Collect the spacer from the rear wheel right side.



- Working from the left side, unscrew and remove the five nuts and remove the crown and the bolts.



- Undo and remove the five screws and remove the anti-vibration buffer holder.
- Check the anti-vibration buffers according to the routine maintenance table.



See also

[Adjusting](#)

Checking the rear wheel



CHECK THAT ALL THE PARTS ARE IN GOOD CONDITIONS, ESPECIALLY THOSE MENTIONED BELOW.

REAR WHEEL BEARINGS

Carry out the check with the bearings fitted on the wheel.

ROTATION CHECK

- Manually rotate the inside ring of each bearing. Rotation must be constant, smooth and noiseless.

If one or both bearings do not fall within the control parameters:

- Replace both wheel bearings.



**ALWAYS REPLACE BOTH BEARINGS.
ALWAYS REPLACE THE BEARINGS WITH OTHERS OF THE SAME TYPE.**

- Check the radial and axial clearance.

Axial clearance: a minimum axial clearance is allowed.

Radial clearance: none.

If one or both bearings do not fall within the control parameters:

- Replace both wheel bearings.

REAR WHEEL GASKETS

- Check that the gaskets are in good conditions; replace them if they show signs of damage or excessive wear.



**ALWAYS REPLACE BOTH GASKETS.
ALWAYS REPLACE THE GASKETS WITH OTHERS OF THE SAME TYPE.**

REAR WHEEL PIN

- Using a dial gauge, check the wheel pin eccentricity (1). If the eccentricity exceeds the limit value, replace the wheel pin (1).

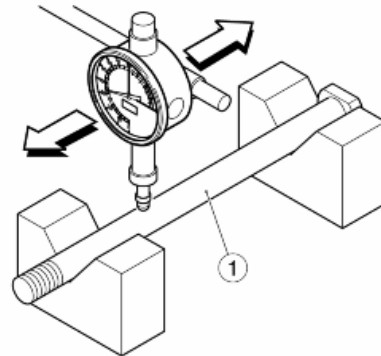

Characteristic

Maximum eccentricity:

0.25 mm (0.0098 in)

REAR WHEEL RIM

- Using a dial gauge, check that the radial (A) and the axial eccentricity (B) of the rim (2) do not exceed the limit value.

An excessive eccentricity is usually caused by worn or damaged bearings. Replace the rim (2) if after replacing the bearings, the value is not within the specified limit.

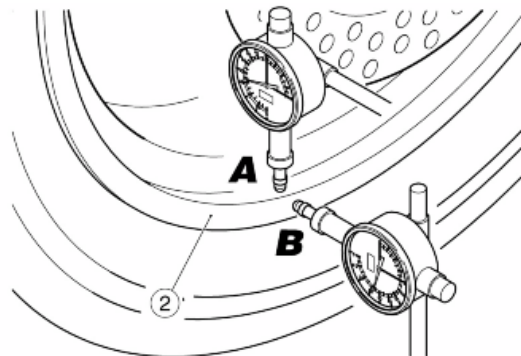

Characteristic

Maximum radial and axial eccentricity:

2 mm (0.0079 in)

Shock absorbers

Removing

- Place the optional under-ump and rear wheel service stands.
- Unscrew and remove the upper screw and collect the washer.



- Loosen the under-ump optional service stand to lower the engine.
- Undo and remove the lower screw and collect the nut.
- Remove the shock absorber.



INDEX OF TOPICS

CHASSIS

CHAS

Swinging arm

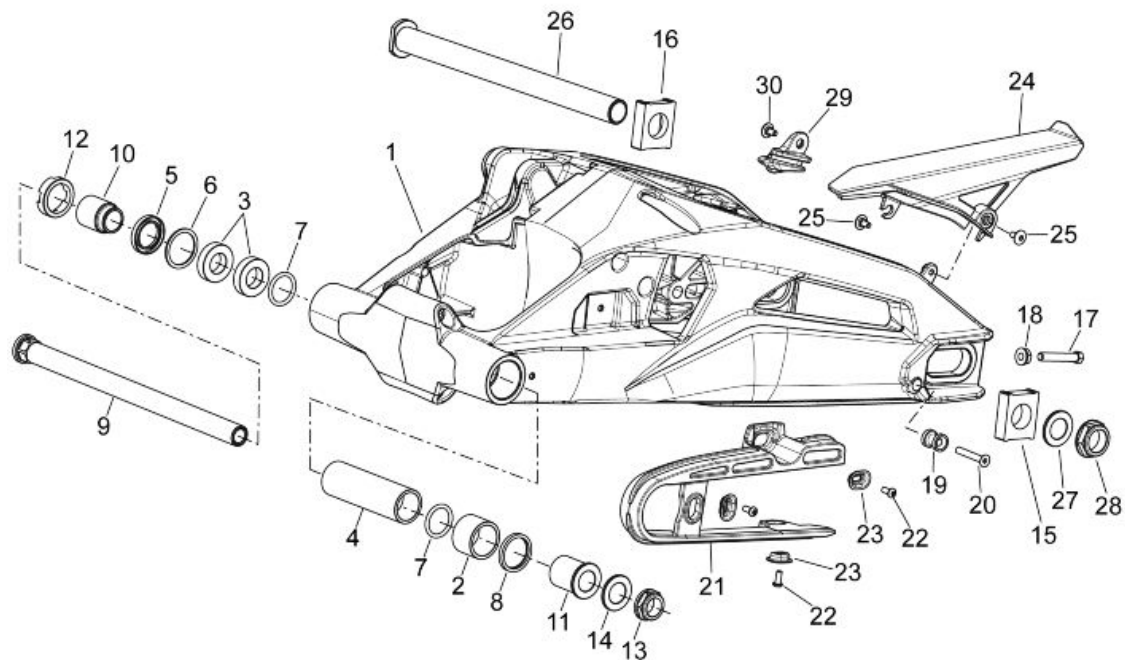

Key:

1. Swingarm
2. Roller casing
3. Ball bearing
4. Internal spacer
5. Sealing ring
6. Seeger ring for hole
7. O-ring
8. Sealing ring
9. Swing arm pin
10. Adjustment bushing
11. Swingarm pin internal bushing
12. Swingarm pin ring nut
13. Rear wheel bolt nut
14. Rear wheel pin washer
15. Left chain guide slider
16. Right chain guide slider
17. Chain tensioner set screw
18. Serpress nut M8

19. Rear stand bushing
20. TSPEI screw M6x40
21. Chain guide slider
22. TBEI screw M5x12 10.9
23. Slider cap
24. Chain guard
25. TBEI special screw M5x12
26. Rear wheel pin
27. Washer 25.2x36x1
28. Wheel bolt nut M25x1.5
29. Counterslider
30. TBEI special screw M5x12

Removing

- Remove the rear wheel.
 - Support the vehicle by means of the engine service stand and a hoist with belts fastened to the rear section of the frame.
 - Remove the rear service stand.
 - Undo and remove the two lower swing-arm screws.
 - Remove the cable guide.
-
- Slide off the rear calliper holding plate, keeping it linked to the brake pipe.



CAUTION

DO NOT ACTUATE ON THE REAR BRAKE LEVER AFTER REMOVING THE WHEEL. OTHERWISE, THE CALLIPER PLUNGERS COULD GO OUT OF THEIR SEAT, RESULTING IN BRAKE FLUID LEAKAGE.



- With the specific box-spanner, unscrew and remove the locking ring nut.



- Working from the left side, unscrew and remove the nut and collect the washer.



**REMOVAL SHOULD BE CARRIED OUT WITH
UTMOST CAUTION.
SUPPORT THE SWINGARM FROM THE FRONT
TO AVOID ACCIDENTAL FALLS.
PLACE A WOODEN SUPPORT UNDER THE
FRONT PART OF THE REAR SWINGARM TO
PREVENT IT FROM LOWERING AND TO KEEP
IT UPRIGHT.**



- Working on the right side, unscrew and remove the swingarm bolt.



**UPON REMOVING THE REAR SWINGARM PAY
ATTENTION NOT TO JAM THE GEARING
CHAIN.**



See also

[Removing the rear wheel](#)

Drive chain

Adjusting

The vehicle is fitted with an endless chain, without master link.

NOTE

CARRY OUT MAINTENANCE OPERATIONS AT HALF THE INTERVALS SHOWN IF THE VEHICLE IS USED IN WET OR DUSTY AREAS, OFF ROAD OR FOR SPORTING APPLICATIONS.

CLEARANCE CHECK

To check the backlash:

- Shut off the engine.
- Place the vehicle on the service stand.
- Engage neutral gear.
- Check that at a point between the pinion and the crown on the lower branch of the chain the vertical oscillation is around 25 mm (0.98 in).
- Move the vehicle forward so as to check vertical oscillation in other positions too. backlash should remain constant during all wheel rotation phases.

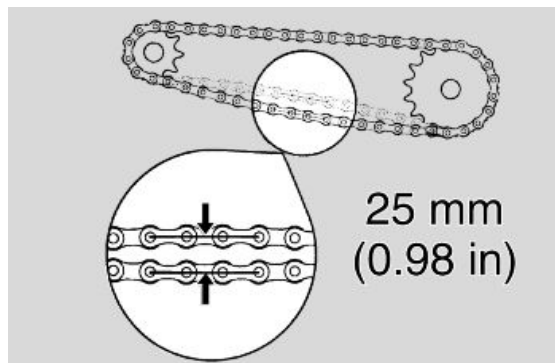

ADJUSTMENT

CAUTION

TO ADJUST THE CHAIN, GET THE APPROPRIATE REAR SERVICE STAND (OPT).

If you need to adjust chain tension after the check:

- Place the vehicle on its OPTIONAL rear service stand.
- Loosen the nut (1) completely.
- Loosen both lock nuts (4).
- Actuate on the set screws (5) and adjust the chain backlash checking that the references (2 - 3) match on both sides of the vehicle.
- Tighten both lock nuts (4).
- Tighten the nut (1).
- Check chain backlash.

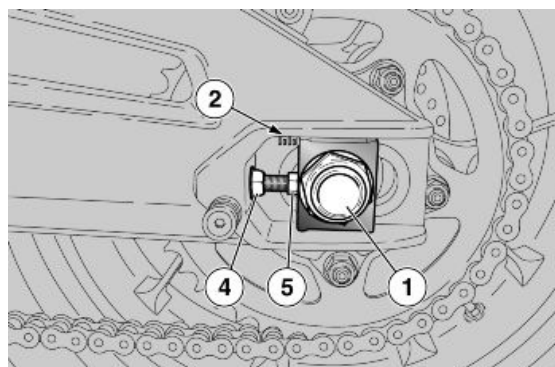

CAUTION

WHEEL CENTRING IS CARRIED OUT BY USING THE FIXED REFERENCES (2-3) WITHIN

THE SEATS OF THE CHAIN TENSIONER PADS ON THE SWING ARMS, IN FRONT OF THE WHEEL PIN.

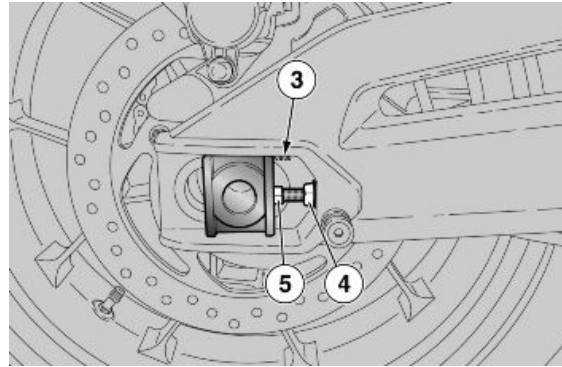

CHECKING THE CHAIN, THE PINION AND THE CROWN FOR WEAR

Furthermore, check the following parts and make sure the chain, the pinion and the crown do not show:

- damaged rollers;
- loosened pins;
- dry, rusty, flattened or jammed chain links;
- excessive wear;
- missing sealing rings;
- excessively worn or damaged pinion or crown teeth.



IF THE CHAIN ROLLERS ARE DAMAGED, THE PINS ARE LOOSE AND/OR THE O-RINGS ARE MISSING OR DAMAGED, THE WHOLE CHAIN UNIT (PINION, CROWN AND CHAIN) SHOULD BE REPLACED.

LUBRICATE THE CHAIN ON A REGULAR BASIS, PARTICULARLY IF YOU DETECT DRY OR RUSTY PARTS.

FLATTENED OR JAMMED CHAIN LINKS SHOULD BE LUBRICATED AND GOOD OPERATING CONDITIONS RESTORED.



THE GEARING CHAIN HAS SEALING RINGS AMONG THE LINKS THAT KEEP THE GREASE INSIDE.

ADJUST, LUBRICATE, WASH AND REPLACE THE CHAIN WITH UTMOST CAUTION.

CLEANING AND LUBRICATION

Do not wash the chain with water jets, steam jets, high-pressure water jets and highly flammable solvents.

- Wash the chain with fuel oil or kerosene. Maintenance operations should be more frequent if there are signs of quick rust.

Lubricate the chain at the intervals specified on the routine maintenance table and whenever necessary.

- After washing and drying the chain, lubricate it with spray grease for sealed chains.

Exhaust

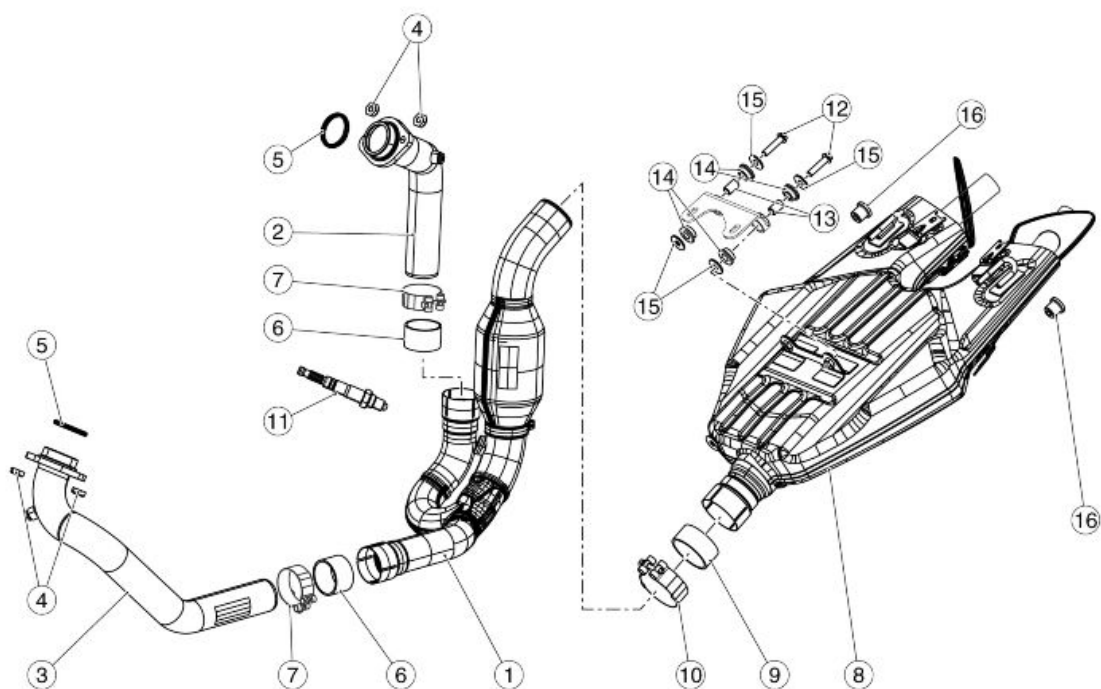

Key:

1. Central exhaust manifold
2. Rear main exhaust manifold
3. Front main exhaust manifold
4. Self-locking nut M8
5. Head exhaust gasket
6. Manifold exhaust gasket
7. Manifold clamp
8. Silencer
9. Silencer gasket
10. Silencer clamp
11. Lambda probe
12. TE flanged screw M8 x 35
13. Spacer bushing
14. Retroreflector supporting rubber ring
15. Washer
16. Muffler fixing rubber ring

Removing the tail pipe

- Loosen the clamp between the exhaust end and the manifold.



- Undo and remove the upper screw.



- Protect the swingarm so as not to spoil it while removing the exhaust end.
- Keeping the plastic cover up, undo and remove the two central screws and collect the washers.
- Then remove the exhaust end.



Removing the manifold - tail pipe

- Remove the front exhaust manifold.
- Remove the lambda probe.
- Loosen the clamp of the rear exhaust manifold.



- Remove the manifold - end coupling.

**See also**

[Removing the exhaust manifold](#)

Removing the exhaust manifold

The engine and the exhaust system components get very hot and remain in this condition for a certain time interval after the engine has been switched off. Before handling these components, make sure that you are wearing insulating gloves or wait until the engine and the exhaust system have cooled down.

FRONT

- Unscrew and remove the two nuts on the head exhaust stud bolts.



- Loosen the clamp.
- Remove the exhaust manifold.



REAR

- Loosen the exhaust pipe between the manifold and the exhaust end.
- Unscrew and remove the two nuts on the head exhaust stud bolts.

**See also**

[Removing the manifold - tail pipe](#)

Removing the lambda sensor

- Disconnect the lambda probe connector.



- Unscrew and remove the lambda probe.



INDEX OF TOPICS

BRAKING SYSTEM

BRAK SYS

Interventions rules

CAUTION

THE FRONT BRAKE DISC SHAPE DOES NOT CHANGE THE OPERATING AND MAINTENANCE SPECIFICATIONS OF THE SYSTEM.

Rear brake calliper

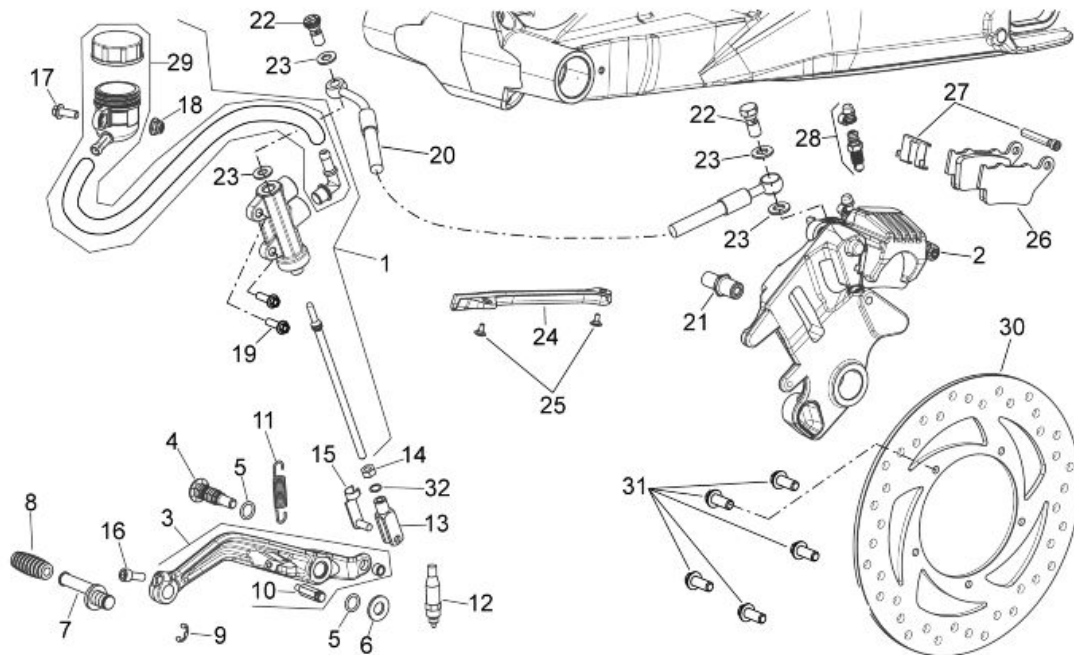

Key:

1. Brake pump together with reservoir
2. Rear brake calliper
3. Rear brake lever
4. Rear brake lever pin
5. O-ring
6. Washer 10.5x21x2
7. Brake lever pin
8. Rubber ring for lever
9. Seeger ring
10. Spring retaining pin
11. Rear brake lever spring
12. Micro-switch
13. Fork Nut M6
14. Clips for gear fork

- 15.TCEI screw M6x16
- 16.TE flanged screw M6x16
- 17.Flanged self- locking nut M6
- 18.TE flanged screw M6x20
- 19.Rear brake pipe
- 20.Brake plate stop pin
- 21.Oil pipe screw
- 22.Washer 10x14x1.6
- 23.Brake pipe protection
- 24.TBEI flanged screw M5x9
- 25.Rear brake pads - pair
- 26.Screws + Calliper springs
- 27.Air bleed
- 28.Oil reservoir assembly
- 29.REAR BRAKE DISC
- 30.TE flanged screw M8x20
- 31.O-ring

Front brake calliper

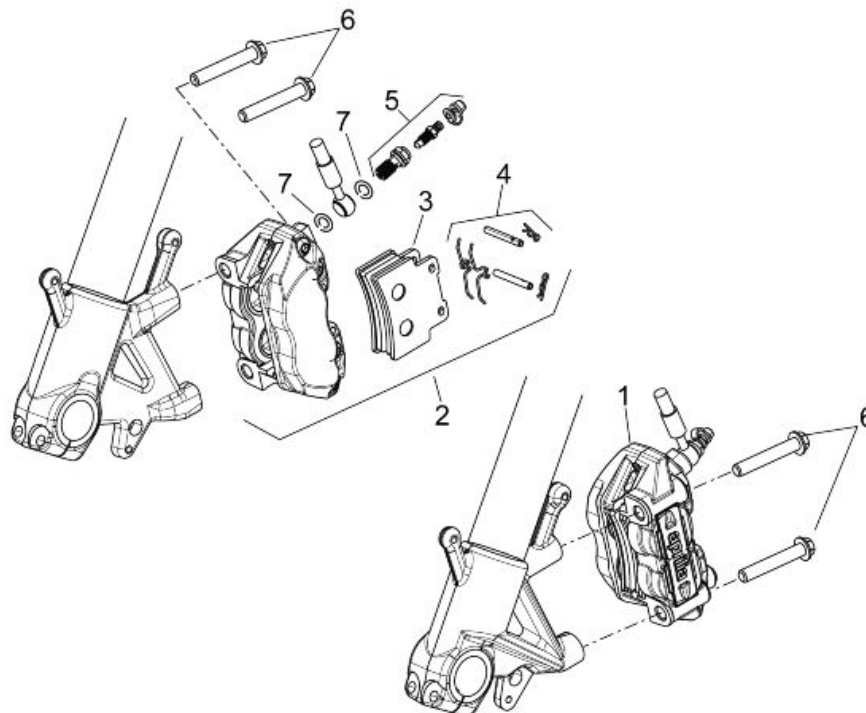

Key:

- 1. Left front brake calliper

2. Front brake calliper
 3. Front brake pads - pair
 4. Pin + calliper spring
 5. Bleeding Kit
 6. TE flanged screw M10x1.25x55
 7. Copper washer
-

Front brake pads

Removal

- Turn the pins and remove both split pins.



- Remove both pins.



- Collect the anti-vibration springs.
- Extract one pad at a time.

CAUTION

AFTER REMOVING THE PADS, DO NOT OPERATE THE BRAKE CONTROL LEVER OR THE CALLIPER PLUNGERS COULD GO OUT OF THEIR SEATS RESULTING IN BRAKE FLUID LEAKS.

Rear brake pads

Removal

- Remove the safety circlip.



- Unscrew and remove the pin.



- Extract one pad at a time.

CAUTION

AFTER REMOVING THE PADS, DO NOT OPERATE THE BRAKE CONTROL LEVER OR THE CALLIPER PLUNGERS COULD GO OUT OF THEIR SEATS RESULTING IN BRAKE FLUID LEAKS.



Bleeding the braking system

Front

If there is air in the hydraulic system, it acts as a bearing, absorbing a large part of the pressure from the brake pump and minimising calliper efficiency during braking.

The presence of air is signalled by the "sponginess" of the brake control and poor braking efficiency.



CONSIDERING THE DANGER FOR VEHICLE AND RIDER, IT IS STRICTLY NECESSARY, AFTER REFITTING BRAKES AND RESTORING THE BREAKING SYSTEM TO THE REGULAR USE CONDITIONS, THAT THE HYDRAULIC CIRCUIT BE AIR PURGED.

NOTE

THE FOLLOWING OPERATIONS REFER TO ONLY ONE FRONT BRAKE CALLIPER BUT APPLY TO BOTH CALLIPERS. THE VEHICLE MUST BE ON LEVEL GROUND TO BE PURGED. WHILE PURGING THE HYDRAULIC SYSTEM, FILL THE RESERVOIR WITH THE NECESSARY QUANTITY OF BRAKE FLUID. CHECK THAT, DURING THE OPERATION, THERE IS ALWAYS BRAKE FLUID IN THE RESERVOIR.

- Remove the rubber protection cover from the bleed valve.
- Insert the transparent plastic pipe in the front brake calliper bleed valve and slide the other end of this pipe in a container to collect the fluid.
- Remove the front brake oil reservoir cap.
- Quickly press and release the front brake lever several times and then keep it fully pressed.
- Loosen the bleed valve 1/4 of a turn so that the brake fluid flows into the container. This will release the tension on the brake lever and will make it reach the end of stroke.
- Close the bleed valve before the lever reaches its end of stroke.
- Repeat the operation until the fluid draining into the container is air-bubble free.



NOTE

WHILE PURGING THE HYDRAULIC SYSTEM, FILL THE RESERVOIR WITH THE NECESSARY QUANTITY OF BRAKE FLUID. CHECK THAT, DURING THE OPERATION, THERE IS ALWAYS BRAKE FLUID IN THE RESERVOIR.

- Screw the bleed valve and remove the pipe.
- Top-up the reservoir until the correct brake fluid level is obtained.
- Refit and block the front brake oil reservoir cap.
- Refit the rubber protection cover.

Rear

If there is air in the hydraulic system, it acts as a bearing, absorbing a large part of the pressure from the brake pump and minimising calliper efficiency during braking.

The presence of air is signalled by the "sponginess" of the brake control and poor braking efficiency.

CAUTION

CONSIDERING THE DANGER FOR VEHICLE AND RIDER, IT IS STRICTLY NECESSARY, AFTER REFITTING BRAKES AND RESTORING THE BRAKING SYSTEM TO THE REGULAR USE CONDITIONS, THAT THE HYDRAULIC CIRCUIT BE AIR PURGED. THE VEHICLE MUST BE ON LEVEL GROUND TO BE PURGED. WHILE PURGING THE HYDRAULIC SYSTEM, FILL THE RESERVOIR WITH THE NECESSARY QUANTITY OF BRAKE FLUID. CHECK THAT, DURING THE OPERATION, THERE IS ALWAYS BRAKE FLUID IN THE RESERVOIR.

- Remove the rubber protection cover from the bleed valve.
- Insert the transparent plastic pipe in the rear brake calliper bleed valve and insert the other end of this pipe into a container to collect the fluid.
- Remove the rear brake oil reservoir cap.
- Quickly press and release the rear brake lever several times and then keep it fully pressed.
- Loosen the bleed valve 1/4 of a turn so that the brake fluid flows into the container. This will release the tension on the brake lever and will make it reach the end of stroke.
- Close the bleed valve before the lever reaches its end of stroke.
- Repeat the operation until the fluid draining into the container is air-bubble free.

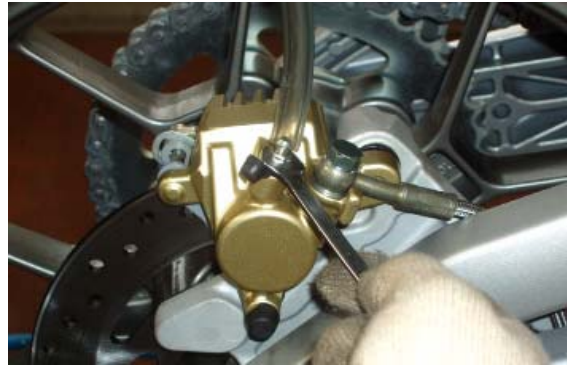
**NOTE**

WHILE PURGING THE HYDRAULIC SYSTEM, FILL THE RESERVOIR WITH THE NECESSARY QUANTITY OF BRAKE FLUID CHECK THAT, DURING THE OPERATION, THERE IS ALWAYS BRAKE FLUID IN THE RESERVOIR.

- Screw the bleed valve and remove the pipe.
- Top-up the reservoir until the right brake fluid level is obtained.
- Refit and lock the rear brake oil reservoir cap.
- Refit the rubber protection cover.

INDEX OF TOPICS

CLUTCH SYSTEM

CLU SYS

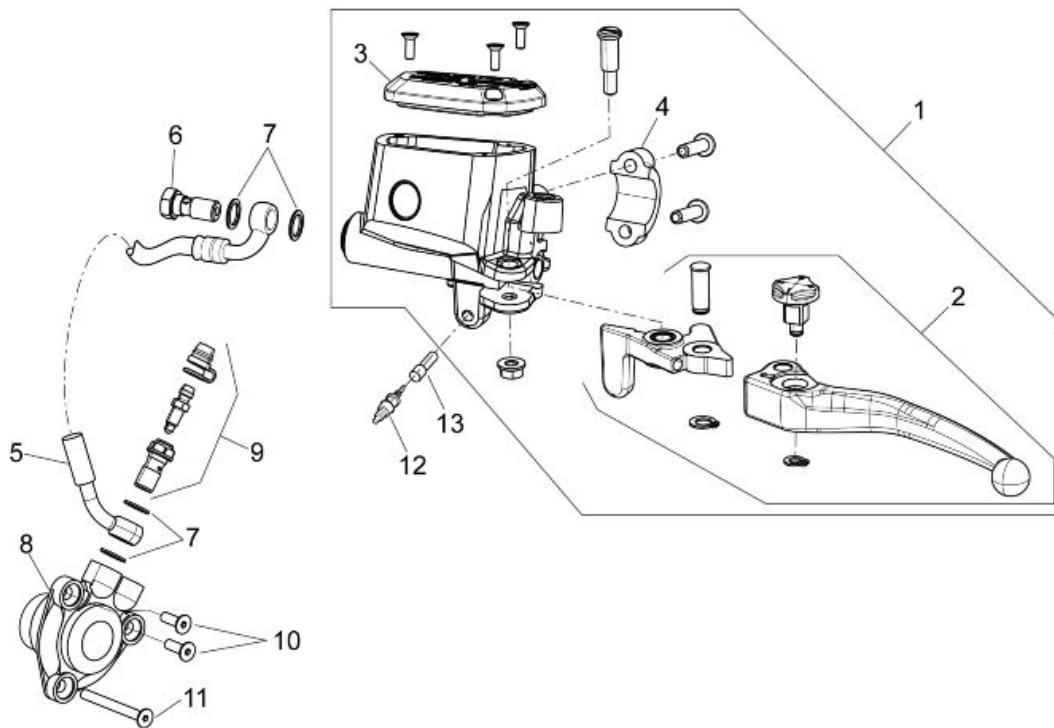
**Key:**

1. Clutch pump
2. Clutch lever
3. Cover
4. U-bolt
5. Clutch pipe
6. Oil pipe screw
7. Washer 10x14x1.6
8. Clutch control cylinder
9. Bleeding Kit
10. TSPEI screw
11. TSPEI screw
12. Stop switch
13. Rubber ring

CAUTION

IF CLUTCH LEVER TRAVEL OR CLUTCH DISENGAGEMENT ARE IRREGULAR, CHECK THE CLUTCH SYSTEM FOR AIR BUBBLES AND BLEED THE SYSTEM THROUGH VALVE (9).

INDEX OF TOPICS

COOLING SYSTEM

COOL SYS

Circuit diagram

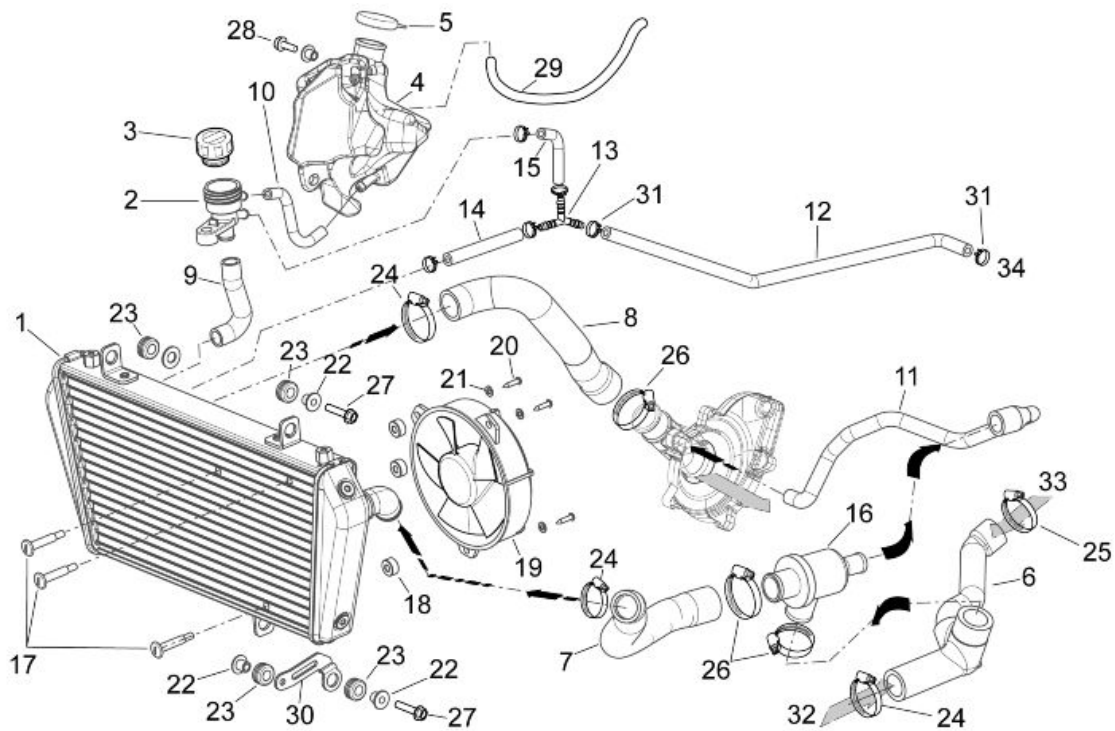

Key:

1. Radiator
2. Opening
3. Cap
4. Expansion tank
5. Expansion tank cap
6. Water pipe
7. Thermostat-radiator pipe
8. Radiator-pump pipe
9. Radiator filling pipe
10. Bleed pipe
11. Valve-motor pump pipe
12. Bleed pipe
13. Y-shape coupling
14. Oil pipe 6x12
15. Oil pipe 6x12
16. Thermostat-valve unit 85 °C (185 °F)
17. Pin
18. Spacer

19. Fan assembly
20. TCB screw 4.2x22
21. Washer 5.3x10x1
22. Front headlamp set spring
23. Rubber ring 10x20x10
24. Clic clamp
25. Clic clamp
26. Pipe clamp
27. TE flanged screw M6x25
28. TE flanged screw M6x20
29. Fuel pipe 5.5x10
30. Radiator support
31. Clic clamp
32. From front cylinder
33. From rear cylinder
34. To rear cylinder

Electric fan

- Remove the radiator
- Undo and remove the three screws and collect the washers; remove the electric fan.

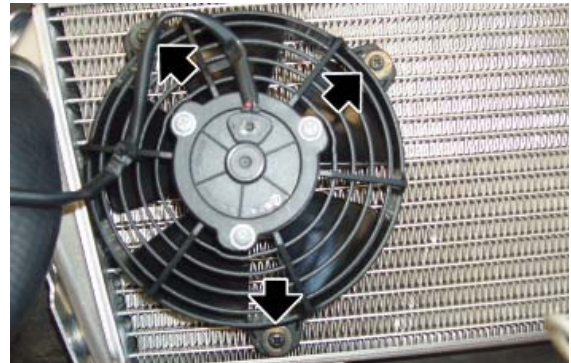

See also

[Removing the radiator](#)

Coolant replacement

- Remove the right side fairing.
- Undo and remove the screw and remove the protection.

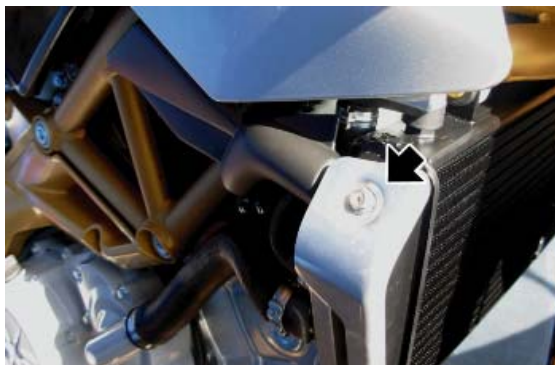

- Place a container of suitable capacity.
- Loosen the screw, move the clamp and slide off the sleeve.



- Remove the cap.

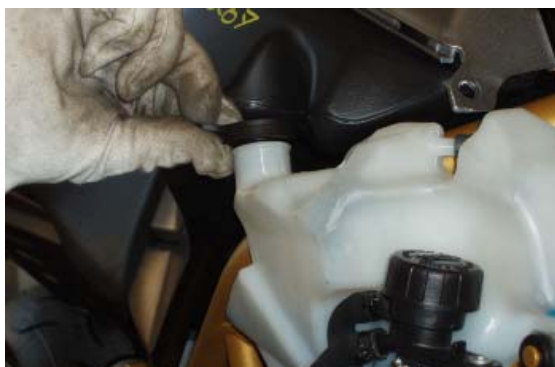

- Empty the system into the specific container.
- Loosen the screw and move the clamp.



- Slide off the sleeve and empty the system completely.

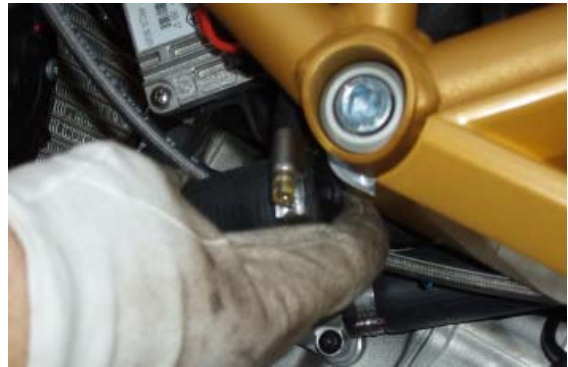

- Refit both sleeves, place the corresponding clamps and tighten their screws.
- Fill the expansion tank up to the marked level.
- After bleeding the air from the tank, place the expansion tank cap.
- Refit the front protection and tighten the screw.
- Fit the right side fairing.

Water pump - overhaul

COVER REMOVAL

- Drain off the cooling circuit completely.
- Undo and remove the five screws.
- Remove the water pump cover.



PUMP ROTOR REMOVAL

- Remove the clutch-side cover.
- Lock the pump shaft with a universal wrench on the hexagonal insert on the shaft.
- Unscrew and remove the anticlockwise nut fixing the rotor.
- Remove the rotor.



- Unscrew and remove the rotor control gear fixing nut and act on the gear hexagonal insert.
- Remove the rotor control gear.
- From the cover inside to the outside, remove the rotor control shaft with a punch and a rubber hammer.



REFITTING

- Upon refitting, carry out the removal operations but in reverse order.

- From the outside to the inside, fit the rotor shaft plus the seal in the corresponding hole on the cover.



- Drive the shaft plus the seal on the cover using the specific tool and a hydraulic press.



- Refill the expansion tank so that the level is between the MAX and MIN marks.
- Fill the system through the radiator cap.

- Place the radiator cap on its seat (to avoid accidental leaks) but do not screw it and start the engine.
- Remove the radiator cap and refill until the radiator plates are completely covered and the water jet from the system breather pipe is continuous.

Removing the radiator

- Empty the cooling system before removing the radiator.
- Working on both sides, undo and remove the screw and collect the washer.

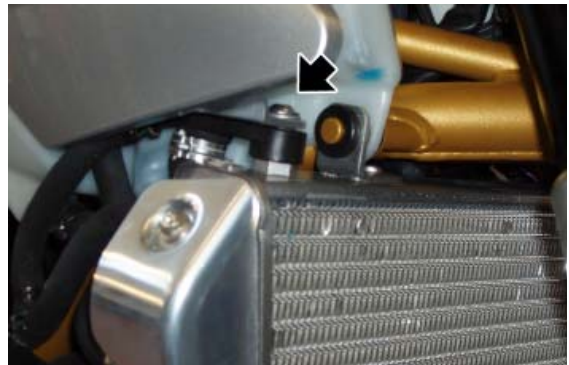

- Undo and remove the screw and collect the nut.



- Remove both clamps and slide off the corresponding pipes.



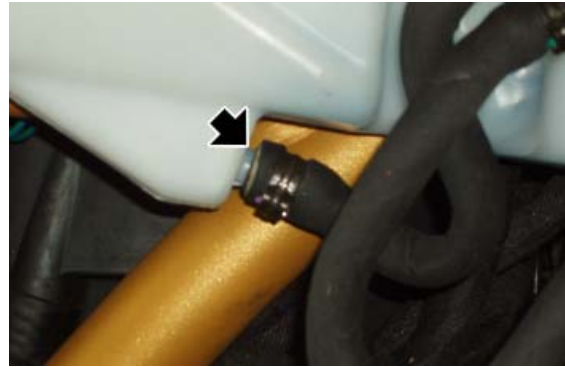

- Disconnect the electric fan connector.



- Undo and remove the fixing screw to chassis.



- Lower the radiator from the upper fixing side to the chassis and remove it by sliding it off toward the vehicle right-hand side.



- To install the radiator, follow the operations explained above but in reverse order, and replace all the clamps removed.
- Restore the correct coolant level.

See also

[Coolant replacement](#)

Removing the expansion tank

- Remove the right side fairing.
- Undo and remove the screw and remove the protection.



- Loosen and move the clamp.
- Slide off the pipe.



- Undo and remove the screw and collect the washer.
- Slide off the expansion tank.



Thermostatic valve

Traditional circuit, three-way thermostatic valve:

1. Hot water inlet from the heads.
2. Outlet towards the short circuit (direct to the pump).
3. Outlet towards the radiator



INDEX OF TOPICS

BODYWORK

BODYW

Seat

SADDLE REMOVAL

- Place the vehicle on the service stand.
- Insert the key (1) in the lock.
- Turn the key (1) anticlockwise
- Paying attention to the belt position, release and lift the saddle (2).

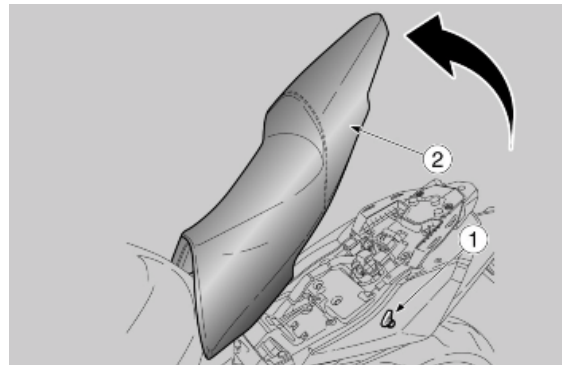

SADDLE LOCK

- Insert the bottom front lugs under the rear frame pin.
- Paying attention to the belt position, set the saddle (2) in its position and push, until it clicks shut.

CAUTION

BEFORE LOWERING AND LOCKING THE SADDLE, CHECK THAT THE KEY HAS NOT BEEN LEFT INSIDE THE GLOVE-BOX / TOOLKIT COMPARTMENT.

Headlight assy.

- Remove the instrument panel.
- Working from the vehicle left side, unscrew and remove the pin, and collect the nut and the washer from the right side.



- Disconnect the front turn indicator cable harness.



- Disconnect the front headlight connector and remove the front headlight assembly.

**See also**

[Instrument cluster support](#)

Taillight assy.

- Remove the tail section.
- Undo and remove the screw. Collect the washer.



- Remove the rear light by sliding it off toward the back.

See also

[Tail guard](#)

Side body panels

The following operations refer to one side of the vehicle, but apply to both.

SIDE FAIRINGS

- Undo and remove the two screws.

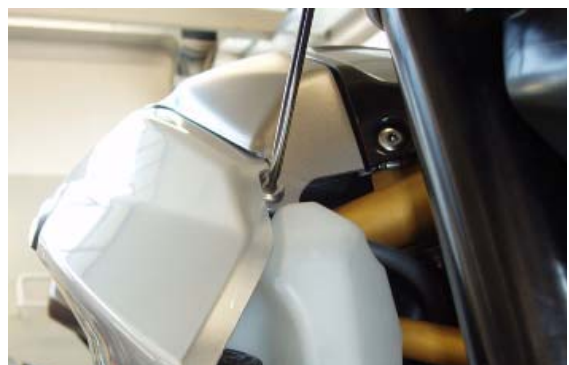



- Remove the cover.



- Undo and remove the screw.



- Remove the side fairing.



LOWER SIDE FAIRINGS

- Remove the side fairing and afterwards remove the saddle.
- Undo and remove the two screws.



- Slide off the lower fairing

See also[Seat](#)

License plate holder

- Remove the saddle.
- Remove the helmet compartment.
- Undo and remove the screw.



- Undo and remove the two screws.



- Remove the clamp.



- Undo and remove the two screws; collect the spacers and the collars.



- Slide off the license plate holder towards the back.

See also

[Seat](#)
[Tail guard](#)

Air box

- Undo and remove the eight screws and remove the air filter.

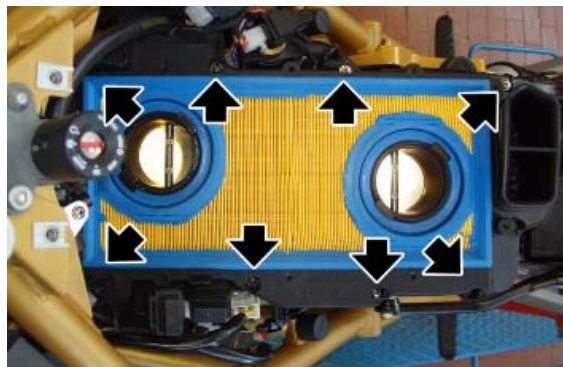

- Undo and remove the inner screw.

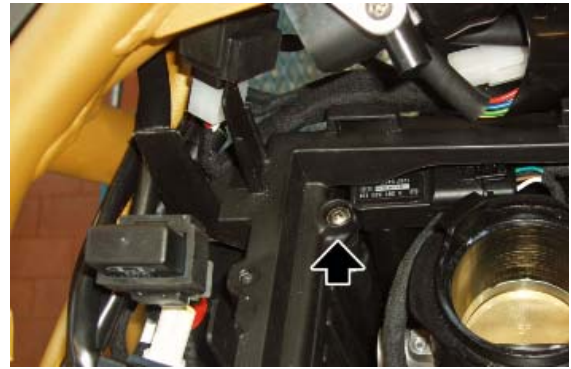

- Undo and remove the screw.



- Remove the filter support partition.



- Slide off the start-up relay.



- Release the cable harness from the clamps .

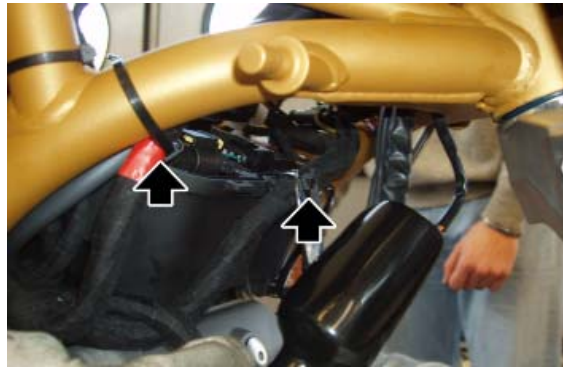

- Working from the left side, undo and remove the screw to remove the cable guide.



- Undo and remove the two screws after loosening the front and rear manifold clamps.



- Loosen the clamp to slide off the bleed pipe.



- Lift the filter casing and working on both cylinders, loosen and move the clamp and slide off the oil vapour recovery pipe.



- Working on the left side, disconnect the two control unit connectors.

CAUTION

THE CONNECTORS ARE MARKED BY THE LETTERS "V" (VEHICLE) AND "E" (ENGINE). DO NOT INTERCHANGE THEM WHEN REFITTING.



- Undo and remove the screw and remove the ground lead.



- Disconnect the two connectors.



- Remove the filter casing together with the throttle body, by lifting it up from behind.

CAUTION

COVER THE COUPLING OPENINGS SO THAT NO FOREIGN BODIES COME IN.



Should the throttle body be removed, disconnect either the map sensor pipes or the inlet ducts; it is necessary to check the air system tightness. Using Axone, check the following parameters:

- a - take the vehicle temperature to 90 °C (194 °F) or above.
- b - front cylinder throttle valve correction between - 60 and 60.
- b - rear cylinder throttle valve correction between - 60 and 60.
- c - potentiometer 1 front throttle valve value is 0.5 or above.
- d - potentiometer 1 rear throttle valve value is 0.5 or above.
- e - the difference of throttle valve correction values between the front and rear cylinders should not exceed 0.6.

See also

[Air filter](#)

Fuel tank

- Remove the saddle.
- Remove the side fairings.

- Working from both sides, undo and remove the screw.



- Remove at least one side air deflector.
- Slide off the key lock plate.



- Undo and remove the two screws and collect the two collars.
- Undo and remove the chamber fixing screws.
- Slide off the "too full" and breather pipes from the chamber.
- Lift the tank by turning it on the hinge.
- Release the petrol pipe.
- Disconnect the pump cable harness.



- Working on the right side, unscrew and remove the nut and slide off the bolt from the left side.



- Keeping the tank up, disconnect the fuel pump connector.



- Working on both sides, disconnect the vapour recovery pipe.

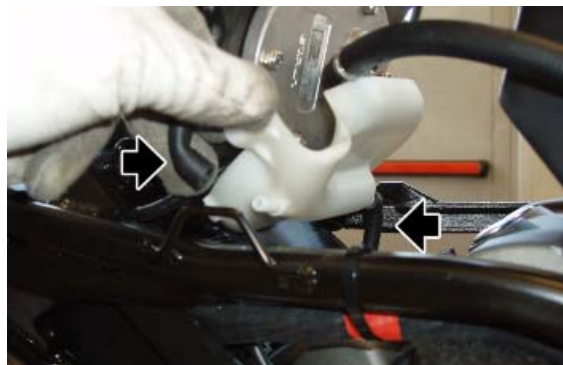

- Protecting the vehicle from potential fuel leaks with a cloth, disconnect the quick coupler.
- Remove the recovery chamber.

**NOTE**

UPON REFITTING THE TANK, KEEP THE FUEL PIPE CONNECTING THE PETROL PUMP TO THE FILTER HOUSING IN THE POSITION INDICATED BY THE FIGURE.

Front mudguard

- Operating from both sides, undo and remove the two screws.
- Remove the front mudguard.

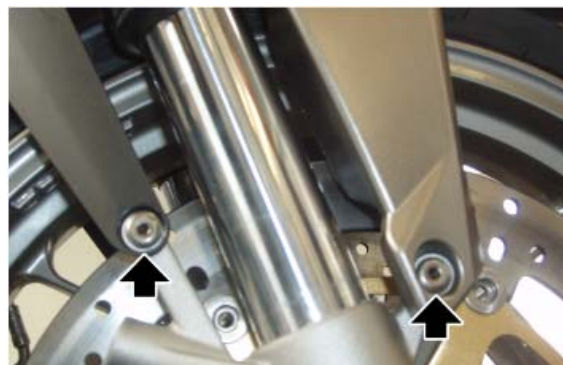



Instrument cluster support

- Undo and remove the two front screws.



- Working on both sides, loosen the nut and the screw and remove them.



- Working from both sides, tilting the front headlight forward, undo and remove the screw and collect the nut.



- Working on the back of the instrument panel, undo and remove the two screws and collect the two washers.

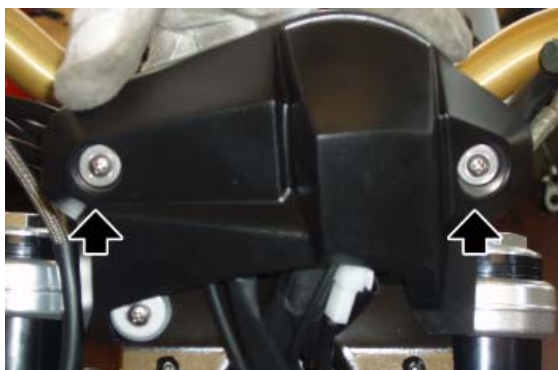

- Remove the instrument panel rear cover.



- Disconnect the instrument panel connector.

- Remove the clamp and disconnect the air temperature sensor.



- Slide off the instrument panel from its support.

Tail guard

- Working from both sides of the vehicle, undo and remove the screw and remove the lateral air intake.



- Operating from both sides of the vehicle, undo and remove the two screws.



- Operating from both sides of the vehicle, undo and remove the screw.



- Undo and remove the 4 screws.

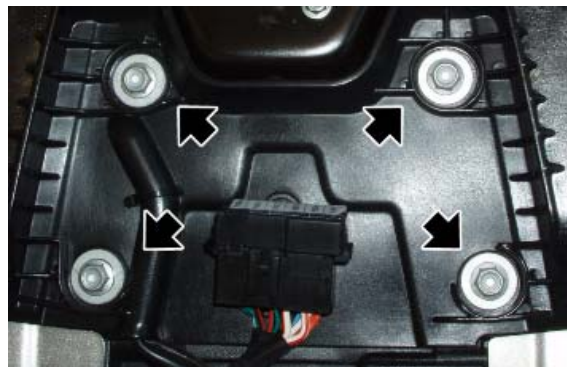

- Undo and remove the two screws and remove the rear light cover.



- Remove the clamp.



- Slide off the auxiliary fuses box.



- Remove the helmet compartment.
- Remove the two clamps.



- Disconnect the two connectors.



- Operating from both sides, slide the exhaust cover tail upward and off.



- Working on the right side, remove the right tail.
- Working on the left side, remove the saddle lock and the left tail.

