

aprilia

1085 2 SCARABEO 50 USA (Ditech Engine)

12/2002-00

www.serviceaprilia.com

workshop manual



8140639 

FOREWORD

- This manual contains information covering normal servicing procedures.
- The information and illustrations contained in this manual are current as of the manual's publication. Since aprilia s.p.a. strives to always improve the quality and usefulness of its vehicles, changes may be made to the vehicles at any time. Thus, it is imperative that users of this manual understand that some information may be out of date for some vehicles. Be sure that the information in this manual applies to the vehicle that you are servicing before you begin any service operations.

- This publication is intended for aprilia dealers and their trained and qualified mechanics. The description of many service and repair operations is intentionally omitted, as it is assumed that the users of this manual have basic mechanical training, basic knowledge of the procedures regarding motor vehicle repair, and have available to them all current information published by aprilia concerning the vehicle. Without these things, the repair or servicing of the vehicle could be affected and could lead to a dangerous condition or accident for the servicing mechanic or the operator.

This manual does not describe all of the procedures necessary to repair and service the vehicle in detail.

Therefore, it is important to be particularly careful in order to avoid any damage to the vehicle, its parts, or to cause injury to the mechanic or the rider. Changes in the technical specifications and servicing procedures that become necessary as a result of changes to aprilia vehicles will be documented and distributed to all aprilia dealers. Therefore, it is necessary that the latest aprilia information be kept available to the servicing mechanics. If you have questions regarding repair and servicing procedures, contact the aprilia Consumer Service (A.C.S.). A.C.S. technical counselors will be able to assist you with any problems that you might face.

For further information refer to:

- ENGINE SERVICE AND REPAIR MANUAL 1096 (USA);
- ENGINE SPARE PARTS CATALOGUE 5601;
- "CHASSIS PARTS" SPARE PARTS CATALOGUE 5601.

aprilia s.p.a. reserves the right to modify any of its models in any manner at any time.

This manual is protected by copyright in all countries. Reproduction by any means, print or electronic, is prohibited. The mention of products or services supplied by entities other than aprilia is made for information purposes only. aprilia is not responsible for the performance or use of any product not specifically recommended or endorsed by aprilia.

First edition: june 2002

Reprint:

Produced and printed by:

CLD s.r.l. Divisione manualistica tecnica
Via D. Alighieri, 37/A - 56012 Fornacette (PI) - Italy
Tel. +39 (0)587 - 42 28 00
Fax +39 (0)587 - 42 28 01
www.cld.it
E-mail: cld@cld.it

On behalf of:

aprilia S.p.A.
Via G. Galilei, 1 - 30033 Noale (VE) - Italia
Tel. +39 (0)41 - 58 29 111
Fax +39 (0)41 - 58 29 190
www.aprilia.com
www.serviceaprilia.com

INTRODUCTION

This manual is divided into sections, chapters and paragraphs, by subject. The procedures described are laid out in single operation, and each operation is indicated by a ♦. The numbered parts shown in the figures are identified in the text with the number in parentheses or with the symbol representing them.

Example (the following text is generic and does not refer to this specific vehicle):

section →

MAIN INDEPENDENT CONTROLS

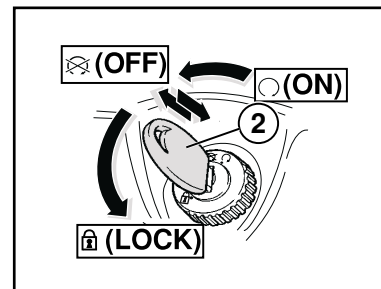

chapter →

STEERING LOCK

safety warning →

▲ WARNING

Never turn the key to position "⊔" while the vehicle is being operated. If you do so, you will lose control of the vehicle, and a crash will ensue.

paragraph →

OPERATION

To lock the steering:

operation →

- ♦ Turn the handlebar completely to the left.

position (2) →

- ♦ Turn the key (2) to position "⊔" (OFF) and press it.

symbol "⊔" →

- ♦ Release the key and rotate it to position "⊔" (LOCK).

- ♦ Remove the key.

SAFETY WARNINGS

Throughout this manual, you will see the following symbols:

▲ WARNING

When you find this symbol on the vehicle or in the vehicle, this indicates that a potential for serious personal injury or death exists. Failure to follow this warning may result in serious risk of personal injury or death, of the mechanic working on the vehicle, the operator of the vehicle, or the general public. It also indicates that serious and permanent damage to the vehicle is possible.

▲ CAUTION

This statement indicates a potential hazard which may result in some personal injury, or damage to the vehicle.

NOTE The word "NOTE" in this manual precedes important information or instructions to which special attention must be given.

GENERAL SAFETY RULES**CARBON MONOXIDE**

If it is necessary to let the engine run in order to carry out some work, make sure that the area in which you are operating is properly ventilated. Never run the engine in enclosed spaces.

If it is necessary to work indoors, use an exhaust evacuation system.

▲ WARNING

The exhaust fumes contain carbon monoxide, a poisonous gas that can cause loss of consciousness and even death.

Run the engine in an open area or, if it is necessary to work indoors, use an exhaust evacuation system.

GASOLINE

Work in a well ventilated area. Keep cigarettes, flames or sparks away from the work area and from the place where gasoline is stored.

▲ WARNING

Gasoline is extremely flammable and becomes explosive under certain conditions.

KEEP GASOLINE AWAY FROM CHILDREN.

HOT COMPONENTS**▲ WARNING**

The engine and the components of the exhaust system become very hot and remain hot for some time after the engine has been stopped. Before handling these components, wear insulating gloves or wait until the engine and the exhaust system have cooled down.

USED ENGINE OIL**▲ WARNING**

Use latex gloves for the maintenance operations that require contact with used oil. Used engine oil may cause skin cancer if repeatedly left in contact with the skin for prolonged periods. Although this is unlikely unless you handle used oil on a daily basis, it is advisable to thoroughly wash your hands with soap and water after handling used oil.

KEEP OIL AWAY FROM CHILDREN.

BRAKE FLUID**▲ WARNING**

The brake fluid can damage painted, plastic or rubber parts. When performing maintenance operations on the braking system, put a clean shop towel on these parts.

Always wear goggles when servicing the brake system with brake fluid. Brake fluid is extremely destructive to your eyes. If you should accidentally get brake fluid in your eyes, flush immediately with a large quantity of cool clear water and seek professional medical assistance immediately.

KEEP BRAKE FLUID AWAY FROM CHILDREN.

COOLANT

In certain conditions, the ethylene glycol contained in the engine coolant is flammable: its flame is invisible, but you can be burned anyway.

▲ WARNING

Avoid spilling the engine coolant on the exhaust system or on the engine components. They may be hot enough to cause the coolant to ignite and burn without a visible flame.

The coolant (ethylene glycol) can cause skin irritation and is poisonous if swallowed.

Engine coolant is extremely attractive to animals and pets, as well as being extremely toxic to them. Do not leave coolant in an open container where animals may be able to drink it.

KEEP COOLANT AWAY FROM CHILDREN.

Do not remove the radiator cap when the engine is hot. The coolant is under pressure and may cause burns.

BATTERY HYDROGEN GAS AND ELECTROLYTE**▲ WARNING**

The battery gives off explosive gases; keep cigarettes, flames and sparks away from the battery. Provide adequate ventilation when operating or recharging the battery.

The battery contains sulphuric acid (electrolyte). Contact with the skin or the eyes may cause serious burns.

Always wear tight fitting goggles and protective clothing when handling battery electrolyte. It is particularly important for you to protect your eyes, since even a minuscule amount of battery acid can destroy your vision. Should you accidentally get even the smallest amount of battery acid on your skin or eyes, immediately flush with large quantities of clear cool water and immediately seek professional medical attention.

The electrolyte is poisonous.

If the electrolyte is accidentally swallowed, drink large quantities of water or milk and then milk of magnesia or vegetable oil. Seek professional medical attention immediately.

KEEP BATTERIES AND ELECTROLYTE AWAY FROM CHILDREN.

PRECAUTIONS AND GENERAL INFORMATION

Follow with care these recommendations when repairing, disassembling and reassembling the vehicle.

▲ WARNING

The use of naked flames is forbidden for any type of operation.

Before commencing any service or inspection operation on the vehicle, switch off the engine and remove the key, wait until the engine and the exhaust system have cooled down and, if possible, raise the vehicle with the suitable equipment onto firm flat ground.

The brakes also get quite hot in operation. Be sure that the brakes have cooled thoroughly before beginning any service operations.

In order to avoid burns, be careful not to touch any parts of the engine or exhaust systems which have not cooled down completely.

Avoid the temptation to hold any hardware or other part of the vehicle in your mouth while working on the motorscooter.

No part of the motorscooter is edible and some of the coatings, plastics, and platings, etc. are noxious if not outright toxic.

If not expressly described, the reassembly of the units is carried out by reversing the order of operations. Handle fuel with the greatest caution. See gasoline warning above.

Never use fuel as a solvent for cleaning the vehicle.

Disconnect the negative cable (-) from the battery when electric welding.

When two or more persons are working together, make sure that each is working in safe conditions.

Be sure that all the mechanics working on any one vehicle are thoroughly briefed as what each will be doing, and insure that one mechanic is responsible for insuring that all safety related items, such as tightening torques, are properly considered.

BEFORE DISASSEMBLY

- Remove any dirt, mud, dust and foreign matter from the vehicle before disassembling the components.
- Use, when necessary, the special tools designed for this vehicle.

▲ WARNING

Do not use makeshift tools for any operation which calls for a special tool. Failure to heed this warning can lead to serious personal injury such as when an ill-fitting wrench slips, and you slam your hand into the workbench or a part of the vehicle.

DISASSEMBLING THE COMPONENTS

- Before disconnecting any pipe, cable, etc., mark each part with a number or distinguishing mark. Each disconnected part must be marked clearly in order that it may be reassembled in the same position as it was before disassembly.
- Clean and carefully wash all disassembled parts with fireproof solvent or a nonflammable detergent.
- Keep mating parts together, since they have worn in during normal use. There are some sets of parts, such as front sprocket, chain, and rear wheel sprocket, which all must be replaced as a set.
- Be careful not to put plastic or painted parts close to heat sources, where they might be damaged.

REASSEMBLING THE COMPONENTS**▲ WARNING**

Never use a circlip twice. When a circlip is removed, it must be replaced with a new one.

When assembling a new circlip be careful not to stretch its ends more than strictly necessary to put it on the shaft.

After installing a circlip, make sure that it is completely and firmly inserted in its seat.

Do not use compressed air to clean the bearings.

NOTE The bearings must rotate freely, without halting or noise otherwise they must be replaced.

- Use only original aprilia SPARE PARTS.
- Use the recommended lubricants.
- Always lubricate parts before reassembly.
- When tightening screws, nuts, and bolts, start with the largest diameter fasteners. When several fasteners are arranged in a pattern, start with the innermost fasteners, and tighten diagonally across the pattern. Tighten each fastener successively before applying the final tightening torque.
- Always replace gaskets, grommets, circlips, O-rings and split pins (cotter pins) with new ones. Before assembling, clean all mating surfaces carefully, removing all traces of the old gasket and gasket sealing compound. Also carefully clean any oil seal you plan to reuse. It is recommended that all oil seals be replaced each time they are disassembled. Gaskets should never be reused. Apply a thin film of lithium based grease to all oil seals before assembling. Install oil seals and bearings with the identification mark or serial number facing outward (visible). Copiously lubricate bearings before installation and before assembly.
- Make sure that each component has been reassembled correctly.
- After any repair or periodic maintenance operation is carried out, the vehicle must be test ridden in an area away from traffic and other hazards.

ELECTRICAL CONNECTORS

The electrical connectors must be disconnected as follows.

Failure to follow these procedures will irreparably damage the connector and wiring.

- ◆ Press in the click tab.

CAUTION

Do not pull the cables to disconnect the two connectors.

- ◆ Grasp the two connectors and disconnect them by pulling in opposite directions.
- ◆ If dirt, rust, dust, or moisture is seen on the connector, blow out the connector with air.
- ◆ Make sure that the cables are correctly crimped to the terminals positioned inside the connectors.

NOTE The two halves of the connector fit together properly in only one orientation. Ensure that the connector is properly aligned before attempting to assemble it.

- ◆ Press the connectors firmly together, listening for the typical “click” sound for those connectors provided with a click tab. Ensure that both halves of the connectors are firmly pressed together.

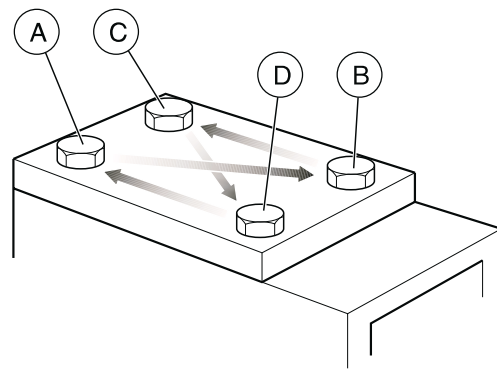
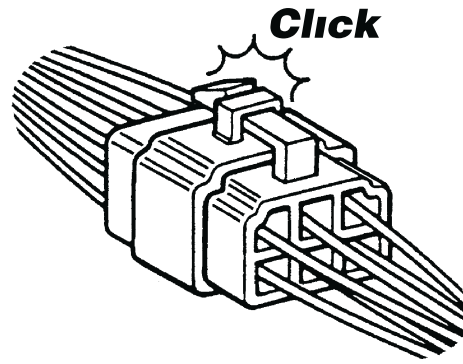

TIGHTENING TORQUES

The table below shows tightening torques for screws and bolts with metric ISO threads, as is used in this vehicle. These are general values to be used if no specific value is given in this manual or other aprilia service literature.

Screw or bolt thread	Spanner	Tightening torque	
		ftlb	Nm
M 4	7	0.3	3
M 5	8	0.6	6
M 6	10	1.0	10
M 8	12	2.5	25
M 10	14	5.0	50
M 12	17	8.0	80
M 14	19	13.5	135
M 16	22	21.0	210

For specific fasteners, see p. 11 (TIGHTENING TORQUES FOR SPECIFIC FASTENERS). If not otherwise indicated, the tightening torques shown should be used for clean and dry threads, at room temperature.

NOTE To avoid damage to the threads, tighten screws and bolts as follows:

- ◆ Run up the fasteners finger tight.
- ◆ Applying half the prescribed tightening torque, tighten the fasteners that are diametrically opposite each other: (A) and (B); (C) and (D).
- ◆ Repeat, applying the prescribed tightening torque.

NOTE In this way the pressure exerted by the fastening elements will be uniformly distributed on the joint surface.

HOW TO USE YOUR SERVICE AND REPAIR MANUAL

ADVICE FOR CONSULTATION

This manual is divided into chapters, each one of which corresponds to a category of main components. To consult them, see the general index, see p. 8 (TABLE OF CONTENTS).

If not expressly indicated otherwise, for the reassembly of the units repeat the disassembly operations in reverse order.

The terms “right” and “left” are referred to the rider seated on the vehicle in the normal riding position.

For normal maintenance operations and for the use of the vehicle, consult the “USE AND MAINTENANCE” manual.

- ★ The operations preceded by this symbol must be repeated on the opposite side of the vehicle.



NOTE When asking your Dealer for spare parts, specify the spare parts code indicated on the SPARE PARTS IDENTIFICATION LABEL.

Write down the identification code in the space here below, in order to remember it also in case of loss or deterioration of the label.

The label is stuck on the left beam of the frame; to be able to read it, remove the inspection cover, see p. 19 (REMOVING THE INSPECTION COVER).

aprilia		N° 5601		YEAR		T	V	W	X	Y
SPARE PARTS CODE NUMBER		I.M.		A	B	C	D	E		
I	UK	A	P	SF	B	D	F	E	GR	
NL	CH	DK	J	SGP	PL	IL	ROK	MAL	RCH	
BM	USA	AUS	BR	RSA	NZ	CDN	HR	SLO		

In this manual the various versions are indicated by the following symbols:

-  **optional**
-  **drum brake version**

VERSION:

-  **Italy**
-  **Poland**
-  **United Kingdom**
-  **Israel**
-  **Austria**
-  **South Korea**
-  **Portugal**
-  **Malaysia**
-  **Finland**
-  **Chile**
-  **Belgium**
-  **Bermuda**
-  **Germany**
-  **United States of America**
-  **France**
-  **Australia**
-  **Spain**
-  **Brazil**
-  **Greece**
-  **South Africa**
-  **Holland**
-  **New Zealand**
-  **Switzerland**
-  **Canada**
-  **Denmark**
-  **Croatia**
-  **Japan**
-  **Slovenia**
-  **Singapore**

POSITION OF THE WARNING ADHESIVE LABELS

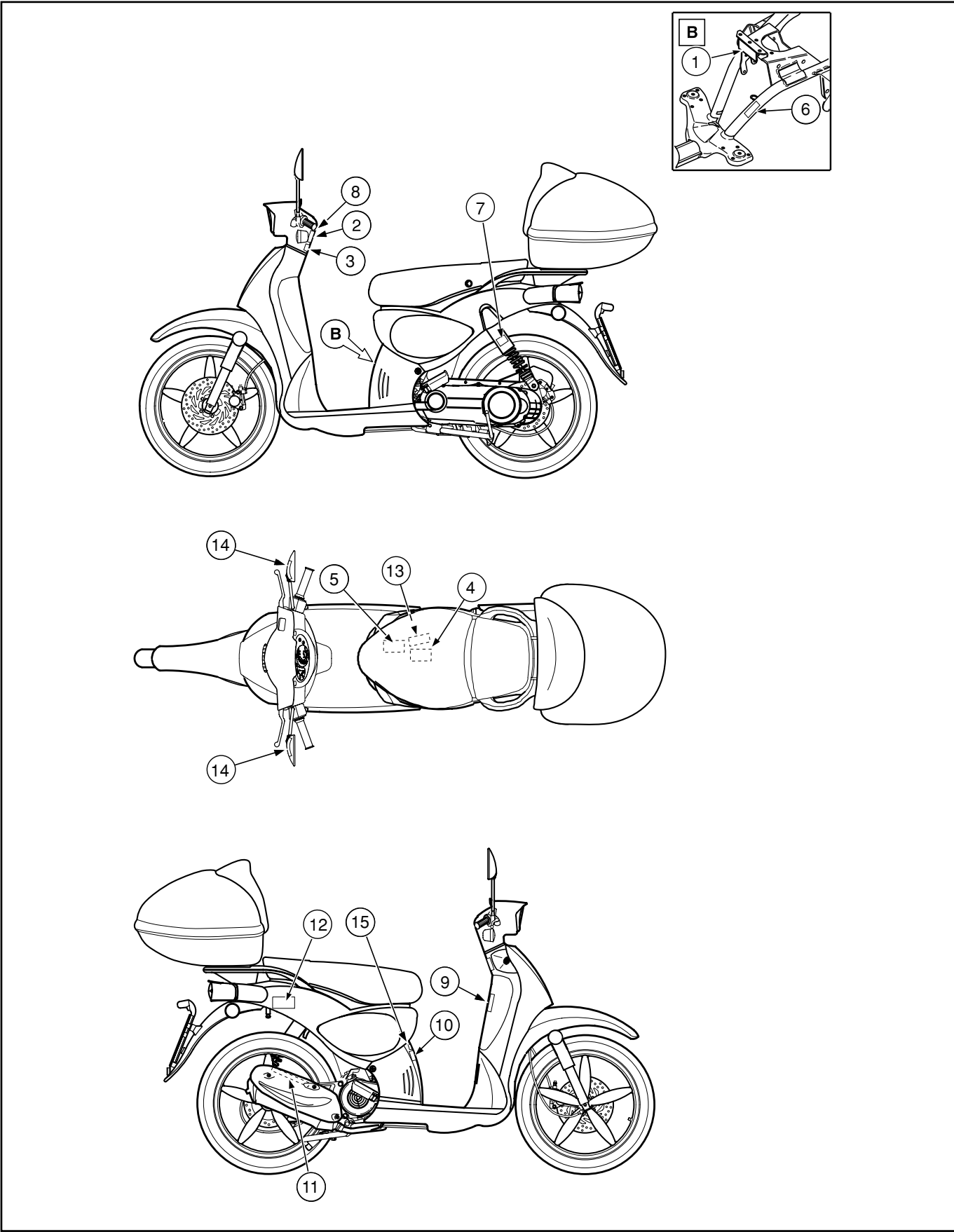

Ref.	Description																																																
1	<p>Manufactured by Aprilia s.p.a.</p> <p>GVWR: 388.8 lbs. GAWR: F 142.2 lbs with 2 1/2" - 16" 42J, 70/90 - 16" 42M tires, E - 16 x 1.6 - DOT - D rim, at 26.1 psi COLD GAWR: R 246.6 lbs with 2 3/4" - 16" 46J, 80/90 - 16" 48M tires, E - 16" x 1.85 - DOT - D rim, at 31.9 psi COLD This vehicle conforms to all applicable Federal Motor Vehicle Safety Standards in effect on the date of manufacture shown above.</p> <p style="text-align: right;">-SCC01-</p> <p style="text-align: center;">MOTOR DRIVEN CYCLE</p>																																																
2	<p>MOTORCYCLE NOISE EMISSION CONTROL INFORMATION</p> <p>THIS 1999 ASP21B0049 MOTORCYCLE, 8219458 MEETS EPA NOISE EMISSION REQUIREMENTS OF 80 dBA AT 6650 closing r.p.m. BY THE FEDERAL TEST PROCEDURE. MODIFICATIONS WHICH CAUSE THIS MOTORCYCLE TO EXCEED FEDERAL NOISE STANDARDS ARE PROHIBITED BY FEDERAL LAW. SEE OWNER'S MANUAL.</p> <p style="text-align: right;">-SCC01-</p>																																																
3	<p>ATTENTION! STARTING PROCEDURE</p> <p>Set on brakes and push START button. See owner's manual.</p>																																																
4	<p>WARNING!</p> <p>Contain sulfuric acid which can cause severe injuries. Avoid contact with skin, eyes or clothing. Antidote: EXTERNAL - Flush with water. INTERNAL - Drink large quantities of water or milk. Follow with milk of magnesia, beaten egg or veg. oil. Call physician immediately. Eyes: Flush with water for 15 minutes and get prompt medical attention. KEEP OUT OF REACH OF CHILDREN. Batteries produce explosive gases. Keep sparks, flames, cigarettes away. Charge only in well-ventilated space. Always wear protective goggles when working around batteries. Always connect the battery vent tube. Failure to heed this warning will cause corrosion of the electrical system.</p>																																																
5	<p>aprilia BATTERYSERVICE</p> <p>WARNING!</p> <p>This battery is completely sealed. Do not attempt to remove the cap. Replace with sealed battery only. Always keep the battery charged (see Owner's Manual). Never disconnect the battery or regulator with the engine running. This will completely destroy the entire electrical system.</p>																																																
6	<table border="1"> <tr> <td colspan="2">aprilia N°</td> <td>YEAR</td> <td>T</td> <td>V</td> <td>W</td> <td>X</td> <td>Y</td> </tr> <tr> <td colspan="2">SPARE PARTS CODE NUMBER</td> <td>I.M.</td> <td>A</td> <td>B</td> <td>C</td> <td>D</td> <td>E</td> </tr> <tr> <td>I</td> <td>UK</td> <td>A</td> <td>P</td> <td>SF</td> <td>B</td> <td>D</td> <td>F</td> </tr> <tr> <td>NL</td> <td>CH</td> <td>DK</td> <td>J</td> <td>SGP</td> <td>PL</td> <td>IL</td> <td>ROK</td> </tr> <tr> <td>BM</td> <td>AUS</td> <td>USA</td> <td>BR</td> <td>RSA</td> <td>NZ</td> <td>CDN</td> <td>HR</td> </tr> <tr> <td></td> <td></td> <td></td> <td></td> <td></td> <td></td> <td></td> <td>SLO</td> </tr> </table>	aprilia N°		YEAR	T	V	W	X	Y	SPARE PARTS CODE NUMBER		I.M.	A	B	C	D	E	I	UK	A	P	SF	B	D	F	NL	CH	DK	J	SGP	PL	IL	ROK	BM	AUS	USA	BR	RSA	NZ	CDN	HR								SLO
aprilia N°		YEAR	T	V	W	X	Y																																										
SPARE PARTS CODE NUMBER		I.M.	A	B	C	D	E																																										
I	UK	A	P	SF	B	D	F																																										
NL	CH	DK	J	SGP	PL	IL	ROK																																										
BM	AUS	USA	BR	RSA	NZ	CDN	HR																																										
							SLO																																										
7	<p>WARNING!</p> <p>• CONTAINS HIGH PRESSURE NITROGEN GAS. • SEE WORKSHOP MANUAL FOR DISPOSAL AND ADJUSTING UNIT. • DO NOT OPEN, DO NOT INCINERATE. INCINERATION, PUNCTURE OR DISASSEMBLY MAY CAUSE THIS UNIT TO EXPLODE.</p>																																																

Ref.	Description																				
8	<p>WARNING!</p> <p>• Misfire phenomena may occur at more than 1000 meters over sea level. • Do not use and more than 1500 meters over sea level and/or with external temperature of less than -10° C because starting problems may occur.</p>																				
9	<p>WARNING!</p> <p>• Wear a helmet, eye protection, and bright protective clothing. • Don't ride after consuming alcohol or other drugs. • Slow down on slippery surface, unfamiliar terrain or when visibility is reduced. • Read owner's manual carefully • Failure to follow these warnings can lead to an accident and serious injuries or death. • USE UNLEADED FUEL MINIMUM OCTANE RATING (R + M) / 2 METHOD 90. • See owner's manual for the correct running in and maintenance of the vehicle.</p>																				
10	<p>WARNING!</p> <p>Do not use any tire other than those recommended and approved by Aprilia. Maintain proper tire inflation. Do not use any tire with less than 1/8" (3mm) tread remaining. Do not repair any tire, nor use a repaired tire. Do not ride your motorcycle overloaded or with an unbalanced load. Failure to follow these warnings can lead to an accident and serious injuries or death. See owner's manual.</p> <p style="text-align: right;">-SCC01- </p> <table border="1"> <tr> <td colspan="2">Tires pressure bar (psi)</td> <td colspan="2">Front tire</td> <td rowspan="2">Tires size</td> <td rowspan="2">Front tire Pirelli Metzeler Cheng Shin Euroswatech 2 1/2" - 16" 42J</td> </tr> <tr> <td>Front tire</td> <td>Rear tire</td> <td>1,9 (28)</td> <td>1,9 (32)</td> </tr> <tr> <td>1 + 1</td> <td>1,8 (26)</td> <td>2,3 (33)</td> <td>2,3 (33)</td> <td>Rear tire</td> <td rowspan="2">Rear tire Pirelli Metzeler Cheng Shin Euroswatech 2 1/2" - 16" 46J</td> </tr> <tr> <td>1 + 1 + 1</td> <td>1,8 (26)</td> <td>2,3 (33)</td> <td>2,3 (33)</td> </tr> </table>	Tires pressure bar (psi)		Front tire		Tires size	Front tire Pirelli Metzeler Cheng Shin Euroswatech 2 1/2" - 16" 42J	Front tire	Rear tire	1,9 (28)	1,9 (32)	1 + 1	1,8 (26)	2,3 (33)	2,3 (33)	Rear tire	Rear tire Pirelli Metzeler Cheng Shin Euroswatech 2 1/2" - 16" 46J	1 + 1 + 1	1,8 (26)	2,3 (33)	2,3 (33)
Tires pressure bar (psi)		Front tire		Tires size	Front tire Pirelli Metzeler Cheng Shin Euroswatech 2 1/2" - 16" 42J																
Front tire	Rear tire	1,9 (28)	1,9 (32)																		
1 + 1	1,8 (26)	2,3 (33)	2,3 (33)	Rear tire	Rear tire Pirelli Metzeler Cheng Shin Euroswatech 2 1/2" - 16" 46J																
1 + 1 + 1	1,8 (26)	2,3 (33)	2,3 (33)																		
11	Muffler stamping.																				
12	<p>WARNING!</p> <p>Do not install accessories or replacement parts not approved by Aprilia as original spare parts. Such installation can degrade the handling and safety of your motorcycle and can cause an accident with serious injury or death. See owner's manual.</p>																				
13	<p> • USARE BENZINA SENZA PIOMBO N.O. min. 95 • USE UNLEADED FUEL RON min. 95</p>																				
14	<p>OBJECTS IN MIRROR ARE CLOSER THAN THEY APPEAR.</p>																				
15	<p>ATTENTION!</p> <p>THE CERTIFICATION LABEL IS UNDER THE PLASTIC PANEL. TO REMOVE THE PANEL SEE OWNER'S MANUAL.</p>																				

TABLE OF CONTENTS

FOREWORD	1	FRONT AND REAR DIRECTION INDICATORS	32
INTRODUCTION	1	CHANGING THE BULB	32
SAFETY WARNINGS	1	REMOVING	
GENERAL SAFETY RULES	2	THE COMPLETE DIRECTION INDICATOR	32
CARBON MONOXIDE	2	REAR LIGHT	33
GASOLINE	2	REPLACING THE REAR LIGHT BULB	33
HOT COMPONENTS	2	REPLACING REAR DIRECTION INDICATOR LAMP BULBS	33
USED ENGINE OIL	2	REMOVING THE REAR LIGHT	33
BRAKE FLUID	2	NUMBER PLATE LAMP BULB	34
COOLANT	2	REPLACING NUMBER PLATE LAMP BULB	34
BATTERY HYDROGEN GAS AND ELECTROLYTE	2	DASHBOARD	34
PRECAUTION AND GENERAL INFORMATIONS	3	CHANGING THE DASHBOARD BULBS	34
ELECTRICAL CONNECTORS	4	REMOVING THE COMPLETE DASHBOARD	35
TIGHTENING TORQUES	4	REMOVING THE DASHBOARD TRANSPARENT SCREEN	35
HOW TO USE		BRAKES	36
YOUR SERVICE AND REPAIR MANUAL	5	DISC BRAKES	37
POSITION OF THE WARNING ADHESIVE LABELS	6	FRONT AND REAR BRAKE	38
TECHNICAL DATA	9	BRAKE PADS	40
TIGHTENING TORQUES FOR SPECIFIC FASTENERS	11	CHECKING WEAR OF THE BRAKE PADS	40
LUBRICANT CHART	12	CHANGING THE BRAKE PADS	40
REGULAR SERVICE INTERVAL CHART	13	BLEEDING THE BRAKING SYSTEM	41
IDENTIFICATION DATA	14	BRAKE CALIPERS	42
FRAME NUMBER	14	REMOVING THE FRONT BRAKE CALIPER	42
ENGINE NUMBER	14	REMOVING THE REAR BRAKE CALIPER	43
ARRANGEMENT OF THE MAIN ELEMENTS	14	TRANSMISSION	44
ARRANGEMENT OF THE INSTRUMENTS	15	CHECKING THE TRANSMISSION OIL LEVEL	44
INSTRUMENTS AND INDICATORS	15	CHANGING THE TRANSMISSION OIL	44
THROTTLE	15	WHEELS / TIRES	45
CHECKING THE OPERATION OF THE THROTTLE CONTROL	15	INSPECTING THE WHEELS	45
ADJUSTING THE THROTTLE CONTROL	16	TIRES	45
FAIRINGS	17	FRONT WHEEL	47
REMOVING THE LUGGAGE RACK	17	DISASSEMBLY	47
REMOVING THE INSPECTION COVER	17	CHECKING	48
REMOVING THE REAR PART OF THE FAIRING	17	REASSEMBLY	48
REMOVING THE REAR MUDGUARD	18	REAR WHEEL	50
REMOVING THE FOOTBOARD	18	DISASSEMBLY	50
REMOVING THE LOWER SHIELD	18	CHECKING THE ENGINE FULCRUM AXIS	51
REMOVING THE FRONT COVER	19	IGNITION SWITCH / STEERING LOCK	51
REMOVING THE FRONT INNER SHIELD	19	REMOVAL	51
REMOVING THE REAR-VIEW MIRRORS	20	AIR CLEANER	52
REMOVING THE FRONT HANDLEBAR COVER	20	REMOVAL THE AIR FILTER	52
REMOVING THE REAR HANDLEBAR COVER	21	REMOVING THE COMPLETE AIR CLEANER CASING	52
REMOVING THE FRONT OUTER SHIELD	21	FORK HEAD	54
REMOVING THE FRONT MUDGUARD	21	CHECKING THE BEARING PLAY	54
REMOVING THE SADDLE SUPPORT	22	ADJUSTING THE BEARING PLAY	54
FUEL TANK	23	REMOVING THE FORK HEAD BEARINGS	55
FUEL	23	FRONT FORK	56
DRAINING THE FUEL TANK	24	REMOVING THE COMPLETE FORK	56
REMOVING THE FUEL PUMP FLANGE	24	DISASSEMBLING THE LOWER FORK LEGS	56
CLEANING THE FUEL FILTER	24	REMOVING THE COMPLETE DAMPER	56
CHECKING THE FUEL LEVEL GAUGE UNIT	24	REAR SUSPENSION	57
REMOVING THE FUEL LEVEL GAUGE UNIT	24	REMOVAL	57
REMOVING FUEL TANK	25	EXHAUST SILENCER	57
2 STROKE OIL TANK	26	DISASSEMBLY	57
CHECKING	26	ENGINE	58
DRAINING	26	REMOVING THE ENGINE FROM THE FRAME	58
REMOVAL	27	ENGINE MOUNTING BUSHINGS	60
BLEEDING THE 2 STROKE OIL TANK	27	REMOVAL	60
DISASSEMBLING THE OIL PUMP	28	BATTERY	61
FUEL PUMP	28	CHECKING AND CLEANING THE TERMINALS	62
BULBS	29	REMOVING THE BATTERY	62
HEADLIGHT	29	CHECKING THE ELECTROLYTE LEVEL	62
ADJUSTING THE HEADLIGHT BEAM VERTICALLY	29	RECHARGING THE BATTERY	63
ADJUSTING THE HEADLIGHT BEAM HORIZONTALLY	29	INSTALLING THE BATTERY	64
CHANGING THE HEADLIGHT BULBS	30	CHANGING FUSES	65
REMOVING THE HEADLIGHT	31	ELECTRICAL SYSTEM	66

TECHNICAL DATA**DIMENSIONS**

Length max.	75 in (1905 mm)
Width max. (at brake levers)	27.76 in (705 mm)
Height max. (at rear view mirrors)	50 in (1270 mm)
Height of saddle	30.71 in (780 mm)
Wheel base	49.21 in (1250 mm)
Minimum ground clearance	5.71 in (145 mm)
Weight unloaded (ready for the road)	189.6 lb (86 kg)

ENGINE

Model	2T
Type	ABAI
No. cylinders	Single horizontal cylinder
Total displacement	1.68 US fl oz (49.38 cm ³)
Bore / stroke	1.61 in / 1.47 in (41.0 mm / 37.4 mm)
Compression ratio	10.5:1
Starting	electric
Clutch	centrifugal
Gearbox	ventilated automatic stepless speed change
Cooling	forced air system

DRIVE

Speed change	automatic stepless
Primary	V belt
Ratios	minimum for stepless gearbox: 2.90 maximum for stepless gearbox: 0.75
Secondary	with gears

CAPACITY

Fuel (including reserve)	2,11 Gal (8 l)
Fuel reserve	0.26 Gal (1 l)
Transmission oil	4.08 US fl oz (120 cm ³)
2-stroke oil (including reserve)	0.4 Gal (1.5 l)
2-stroke oil reserve	0.16 Gal (0.6 l)
Seats	n° 2
Max loading capacity (driver + baggage)	242.51 lb (110 kg)
Max loading capacity (driver + passenger + baggage)	407.85 lb (185 kg)

CARBURETOR

Number	1
Choke	throttle valve BING Ø 0.71 in (Ø 18 mm)

POWER SUPPLY

Fuel	gasoline super DIN 51 600 (4 Star), minimum octane number 98 (N.O.R.M.) and 88 (N.O.M.M.)
------	---

CHASSIS FRAME

Type	single beam split to form double cradle
------	---

SUSPENSIONS	
Front	hydraulic telescopic fork
Travel	3.15 in (80 mm)
Rear	single hydraulic shock absorber
Travel	3.07 in (78 mm)

BRAKES	
Front	disc Ø 8.66 in (Ø 220 mm) with hydraulic transmission
Rear	disc Ø 7.48 in (Ø 190 mm) with hydraulic transmission

WHEELS	
Rims	alloy
Front	1.60 x 16"
Rear	1.85 x 16"

TIRES	
Front	2.50 x 16" 42J SAVA MC 26 CAPRI 46M REINF
Rear	2.75 x 16" 46J SAVA MC 26 CAPRI 52 M REINF
STANDARD INFLATION PRESSURE	
Front	27.55 psi [190 kPa (1.9 bar)]
Rear	31.90 psi [220 kPa (2.2 bar)]
INFLATION PRESSURE WITH PASSENGER	
Front	27.55 psi [190 kPa (1.9 bar)]
Rear	33.55 psi [230 kPa (2.3 bar)]

IGNITION	
Type	T.C.I.
Spark advance	variable with 20° at 4000 rpm
Standard spark plug	NGK CPR 8E
Spark plug electrode gap	0.024 ± 0.002 in (0.6 ± 0.05 mm)
No. engine revs at idling	1900 ± 50 rpm

ELECTRICAL SYSTEM	
Battery	12 V - 4 Ah sealed
Fuse	7.5 A
Generator (permanent magnet)	12 V - 140 W
Low/high beam bulb	12 V - 35 / 35 W
Parking light bulb	12 V - 5 W (W 2.1 x 9.5 d)
Direction indicator light bulbs	12 V - 10 W
Rear parking/brake light bulb	12 V - 5/21 W
License plate light bulb	12 V - 5 W
Dashboard light bulbs	12 V - 1.2 W
Main beam indicator light	12 V - 1.2 W
Direction indicator light	12 V - 3 W
2-stroke oil reserve warning light	12 V - 1.2 W
Injection check light	12 V - 2 W

TIGHTENING TORQUES FOR SPECIFIC FASTENERS

SPECIFIC FASTENERS	ftlb	Nm
Shock absorber-frame coupling	31.83	44
Connecting rod-frame fastening nut	31.83	44
Connecting rod-engine fastening nut	31.83	44
Pumping element-fork sleeve tightening screw	5.06	7
Throttle body clamp screw	1.44	2
Shock absorber-engine coupling	31.83	44
Filter case fastening screw	5.06	7
Cylinder-exhaust pipe fastening nut	7.23	10
Exhaust pipe bracket-engine fastening nut	15.55	21.5
Exhaust silencer fastening screw	5.06	7
Fork clip-wheel pin fastening screw	8.68	12
Front wheel pin nut	25.32	35
Rear wheel nut	94.06	130
Front brake caliper-fork fastening	16.64	23
Brake pump clamps fastening screw	7.23	10
Brake pump-caliper pipe	13.02	18
Brake caliper bleeder cap	10.13	14
Front brake disc fastening screw	16.64	23
Rear brake caliper fastening screw	16.64	23
Handlebar rear break lever screw	5.06	7
Rear brake disc screw	16.64	23
Handlebar clamp fastening screw	31.83	44
Acceleration and starter controls	1.44	2
Steering unit nut	7.23	10
Brake oil tank cap fastening screw	6.51	9
Steering unit self-locking counter-nut	79.59	110
Key commutator screw	8.68	12
Fuel tank fastening screw	7.23	10
Various fuel tank clamps	2.17	3
Tank flange clamp	2.17	3
Fairing fastening screws M6	3.61	5
Fairing fastening screws M5	2.17	3
Self-tapping fairing fastening screws	2.17	3
Rear reflector screws M5	1.44	2

LUBRICANT CHART

Engine oil (recommended):  SUPERBIKE 4, SAE 5W - 40 or  4T FORMULA RACING, SAE 5W - 40.

As an alternative to the recommended oil, it is possible to use other brands of oil with performance levels that meet or exceed the requirements of CCMC G-4, A.P.I. SG.

▲ WARNING

For particularly severe working conditions, or in hot countries, we recommend you use 5W50/10W50 synthetic oil.





Transmission-gear oil (recommended):  F.C., SAE 75W - 90 or  GEAR SYNTH, SAE 75W - 90.



As an alternative to the recommended oil, it is possible to use other brands of oil with performance levels that meet or exceed the requirements of A.P.I. GL-4.

2-stroke oil (recommended):  GREEN HIT 2 or  CITY 2T.



As an alternative to the recommended oil, it is possible to use other brands of oil with performance levels that meet or exceed the requirements of ISO-L-ETC ++, A.P.I. TC ++.

Fork oil (recommended): fork oil  F.A. 5W or  F.A. 20W; an alternative  FORK 5W or  FORK 20W.

Should you wish for a performance somewhere between that offered by  F.A. 5W and  F.A. 20W or  FORK 5W and  FORK 20W, these can be mixed as indicated below:

SAE 10W =  F.A. 5W 67% of volume +  F.A. 20W 33% of volume;

 FORK 5W 67% of volume +  FORK 20W 33% of volume.

SAE 15W =  F.A. 5W 33% of volume +  F.A. 20W 67% of volume;

 FORK 5W 33% of volume +  FORK 20W 67% of volume.



Bearings and other lubrication points (recommended):  AUTOGREASE MP or  GREASE 30.

As an alternative to the recommended product, use other brands of grease for ball bearings, working temperature range -22 °F...+284 °F (-30 °C...+140 °C), drip point 302 °F...446 °F (150 °C...230 °C), high protection against corrosion, good resistance to water and oxidation.

Battery pole protection: Neutral grease or Vaseline.

▲ WARNING

Always use new brake fluid only.

Brake fluid (recommended): the system is filled with  Autofluid FR., DOT 4 (It is also possible to use DOT 5 for the braking system) – the system is filled with  BRAKE 5.1 DOT 4 (It is also possible to use DOT 5 for the braking system).

NOTE Do not mix different brands or types of oil without first checking their basic compatibility.

▲ WARNING

Only use nitrate-free antifreeze and anticorrosive, guaranteeing protection to at least -31 °F (-35 °C).

Engine coolant (recommended):  ECOBLU - 40°C -  COOL.

REGULAR SERVICE INTERVAL CHART

Component	After running-in [312 mi (500 km)]	Every 2,500 mi (4,000 km) or 12 months	Every 5,000 mi (8,000 km) or 24 months
Battery – Electrolyte level	C	C	
Spark plug	C	S	
Air filter	C	S	
Lighting system	C	C	
Brake light switches		C	
Brake fluid (check level)		C	
2-stroke oil	every 1,250 mi (2,000 km): C		
Tires and tire pressure	every month: C		
Wear on front and rear brake pads	C	every 1,250 mi (2,000 km): C	
Rear shock absorber			C
Transmission cables and controls	C	C	
Drive belt			S
Handlebar bearings and steering slack	C	C	
Wheel bearings		C	
Brake discs	C	C	
Throttle operation	C	C	
Piston rings	every 7,440 mi (12,000 km): C		
General operation of vehicle	C	C	
Braking system / brake discs	C	C	
Cylinder cooling system	every 12,400 mi (20,000 km): P (clean externally)		
Brake fluid	every 2 years: S		
Exhaust pipe / silencer			C
2-stroke oil mixer / accelerator functions	C	C	
Transmission oil	S	every 2,500 mi (4,000 km) or 12 months: C	every 5,000 mi (8,000 km) or 2 years: S
Rear pulley pins	every 7,440 mi (12,000 km): S		
Fixed mobile front pulley	every 7,440 mi (12,000 km): S		
Clean injector	every 5,000 mi (8,000 km): P		
Front speed change gear guides and needles (*)			S
Wheels / tires and inflation pressure	C	C	
Lock on nuts and bolts	C	C	
2-stroke oil reserve warning light	C	C	
Fuel pipes	every 2,500 mi (4,000 km): C / every 2 years: S		
Braking system pipes	every 2,500 mi (4,000 km): C / every 4 years: S		
2-stroke oil pipe	C	C	every 2 years: S
Wear on clutch			C

C = check and clean, adjust, lubricate or change, if necessary; **P** = clean; **S** = change; **R** = adjust.

Perform these maintenance operations at one-half of the specified intervals, if your vehicle is often used in rainy or very dusty conditions, or on unpaved roads.

(*) The guides are fitted, do not replace. Replace the needles only.

IDENTIFICATION DATA

Please supply the frame number when you purchase spare parts.

NOTE Do not obliterate or alter the identification numbers under any circumstance. This is illegal in all countries. In addition, alteration of the identification numbers invalidates the warranty.

FRAME NUMBER

The frame number (1) is stamped on the central tube of the frame. To be able to read it, it is necessary to remove the cover (2).

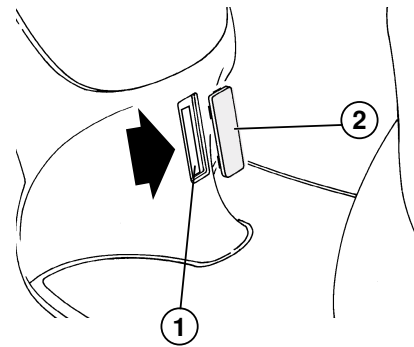

ENGINE NUMBER

The engine number (3) is stamped near the lower support of the rear shock absorber.

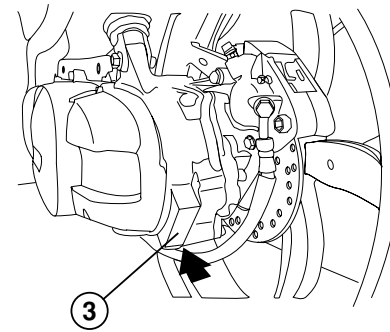

ARRANGEMENT OF THE MAIN ELEMENTS

KEY

- 4) Horn
- 5) Rear brake reservoir
- 6) Fuse carrier
- 7) Battery
- 8) Saddle lock
- 9) Center stand
- 10) Air cleaner
- 11) Inspection cover
- 12) Passenger left footrest (in the countries where required)
- 13) Trunk

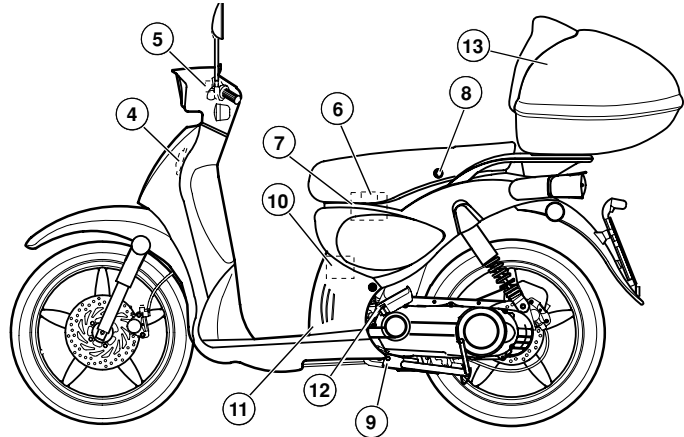

KEY

- 14) Luggage rack
- 15) 2 stroke oil tank
- 16) 2 stroke oil filler cap
- 17) Fuel filler cap
- 18) Ignition switch/steering lock
- 19) Glove compartment
- 20) Bag hook
- 21) Frame number cover
- 22) Front brake reservoir
- 23) Fuel tank
- 24) Anti-theft hook (for the aprilia "Body-Guard" armored cable **OPT**)
- 25) Passenger right footrest (in the countries where required)

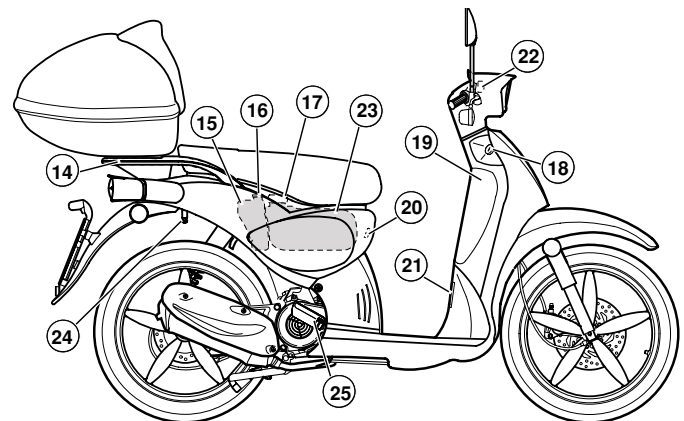

ARRANGEMENT OF THE INSTRUMENTS

KEY

- 1) Electrical controls on the left side of the handlebar
- 2) Rear brake lever
- 3) Left rear-view mirror
- 4) Instruments and indicators
- 5) Right rear-view mirror
- 6) Throttle grip
- 7) Front brake lever
- 8) Electrical controls on the right side of the handlebar
- 9) Ignition switch/steering lock (○ - ⊗ - Ⓜ)

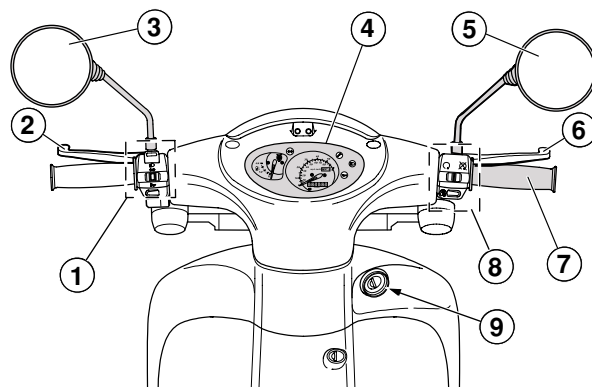

INSTRUMENTS AND INDICATORS

KEY

- 10) Fuel level indicator (Ⓜ)
- 11) Green direction indicator warning light (⇄)
- 12) Speedometer
- 13) Blue high beam warning light (≡▷)
- 14) Red 2 stroke oil reserve warning light (Ⓜ)
- 15) Total miles odometer
- 16) Red Diagnostics warning light (INJECTION CHECK) (⚡)

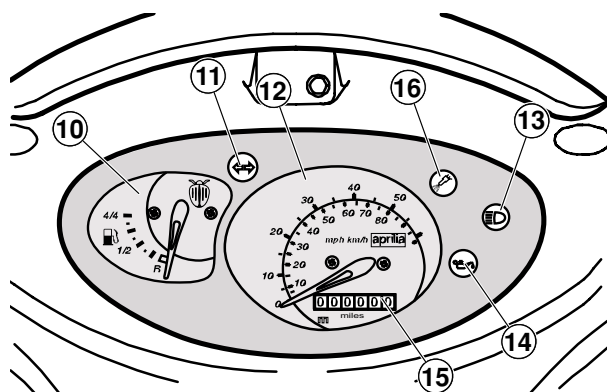

THROTTLE

CHECKING THE OPERATION OF THE THROTTLE CONTROL

Carefully read p. 2 (GENERAL SAFETY RULES).

▲ WARNING

Do not use your vehicle if it has a damaged, kinked or twisted throttle cable. This can interfere with the regular operation of the throttle, and cause the throttle to stick on. This can make you lose control of the vehicle while riding, which can lead to upsets, and subsequent serious injury or death.

Make sure that the rotation of the front forks does not pull on the throttle cable and change the engine idle speed, and that the throttle grip returns smoothly and automatically to its idle position when released. If it does not:

NOTE For the lubrication of the components use the specific lubricant available on the market.

- ◆ Check the position and lubrication of the following components:
 - throttle cable sheath;
 - throttle grip adjuster (17);
 - cable ends;
 - throttle control.

Check the throttle control control adjustment, see above (CHECKING THE OPERATION OF THE THROTTLE CONTROL).

NOTE Use a good grade of vehicle cable lubricant to lubricate the components of the throttle system.

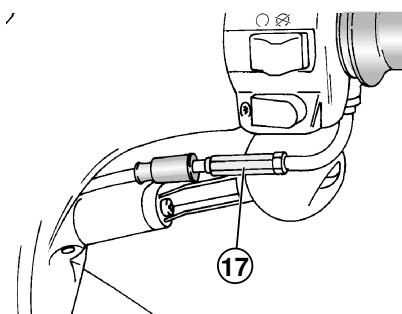

ADJUSTING THE THROTTLE CONTROL

Carefully read p. 2 (GENERAL SAFETY RULES).

NOTE Before carrying out any operation, check the correct functioning of the throttle control, see p. 17 (CHECKING THE OPERATION OF THE THROTTLE CONTROL).

▲ WARNING

If the throttle sticks open, you will lose control of your vehicle and a serious accident could result.

If any fastener in the throttle system becomes loose, likewise you will lose control of your vehicle.

Either situation can lead to an upset or collision with subsequent serious injury or death.

The play of the throttle cable must be between **0.08 – 0.12 in (2 – 3 mm)**, measured at the edge of the grip, see the illustration above.

To adjust the cable:

- ◆ Place the vehicle on the center stand.
- ◆ Pull back the rubber boot (1).
- ◆ Loosen the lock nut (2).
- ◆ Rotate the adjuster (3) in such a way as to restore the prescribed value.
- ◆ After the adjustment, tighten the lock nut (2) and check the play again.
- ◆ Replace the rubber boot (1).

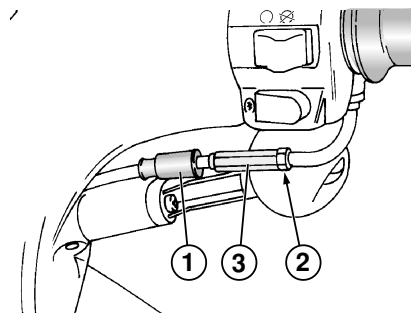
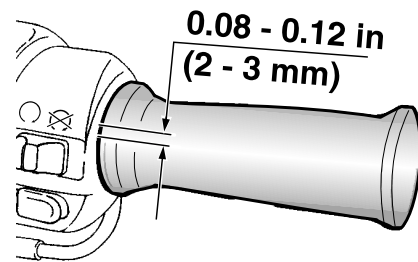

▲ WARNING

Exhaust gases contain carbon monoxide, which is extremely poisonous if inhaled.

Do not start the engine in closed or badly-ventilated rooms.

Failure to observe this warning may cause loss of consciousness or even lead to death by asphyxia.

▲ WARNING

After you have adjusted the throttle, rotate the handlebars

full left and full right with the engine idling.

Check to ensure that the idle sound is not affected by this. Also check that the throttle smoothly and fully closes when released.

FAIRINGS**REMOVING THE LUGGAGE RACK**

Carefully read p. 2 (GENERAL SAFETY RULES).

- ◆ Place the vehicle on the center stand.
- ◆ Remove the cover shown in the figure (1).
- ◆ Unscrew and remove the two screws (2).
- ◆ Unscrew and remove the screw (3).
- ◆ Remove the luggage rack.

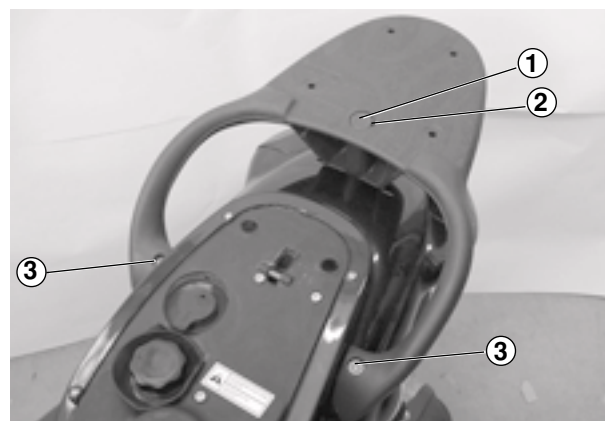

NOTE The bushings (4) and (5) are not interchangeable and must be positioned correctly in the appropriate seats.

REMOVING THE INSPECTION COVER

Carefully read p. 2 (GENERAL SAFETY RULES).

▲ WARNING

Before carrying out the following operations, let the engine and the exhaust silencer cool down until they reach room temperature, in order to avoid burns.

▲ CAUTION

Handle the plastic and painted components with care and avoid scraping or damaging them.

- ◆ Place the vehicle on the center stand.
- ◆ ★Unscrew and remove the screw (4).
- ◆ Remove the inspection cover (5).

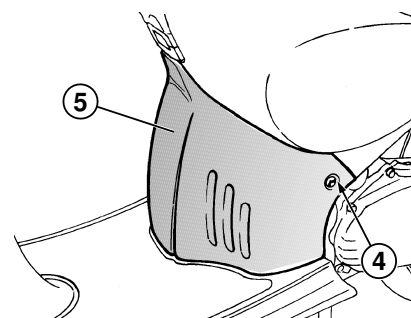
**REMOVING THE REAR PART OF THE FAIRING**

- ◆ Remove the luggage rack, see above (REMOVING THE LUGGAGE RACK).
- ◆ Remove the inspection cover, see above (REMOVING THE INSPECTION COVER).
- ◆ Unscrew and remove six screws (6).

▲ CAUTION

Handle the plastic and painted components with care and avoid scraping or damaging them.

- ◆ Slightly pull outward and raise upward the front portion of the rear part of the fairing (7).
- ◆ Move the rear part of the fairing (7) backwards a few inches.
- ◆ Free the cables from the 2 plastic clamps.
- ◆ Disconnect the rear light main connector (8).
- ◆ Completely remove the rear part of the fairing (7).

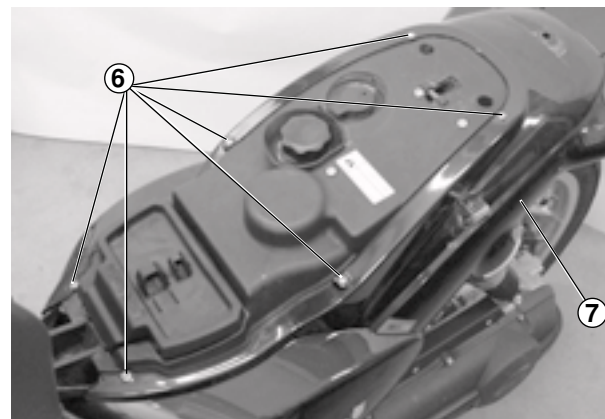
**Upon reassembly:**

- ◆ Position the rear part of the fairing in its seat (see the last four steps in REMOVING THE REAR PART OF THE FAIRING).

NOTE Tighten the six screws (6) after reassembling the luggage rack.

- ◆ Turn the six screws (6) without tightening them.
- ◆ Replace the luggage rack, see above (REMOVING THE LUGGAGE RACK).
- ◆ Make sure that the rear part of the fairing is positioned correctly.
- ◆ Tighten the six screws (6).

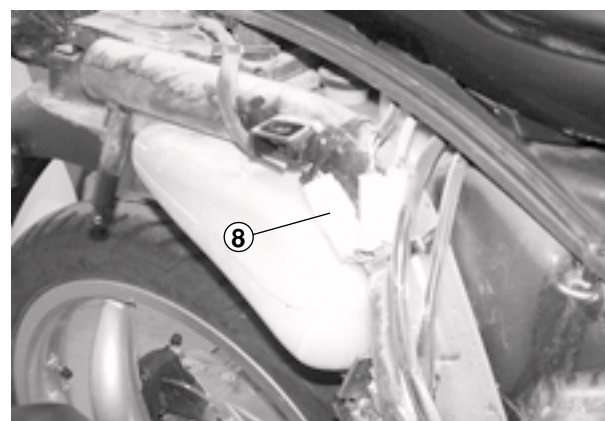

REMOVING THE REAR MUDGUARD

Carefully read p. 2 (GENERAL SAFETY RULES).

- ◆ Remove the rear part of the fairing, see p. 19 (REMOVING THE REAR PART OF THE FAIRING).
- ◆ Disconnect the number plate lamp cables.
- ◆ Unscrew the 4 screws (1).
- ◆ Remove the mudguard (2).

NOTE Take note of the positions of the number plate lamp cables in order to replace them correctly during reassembly.

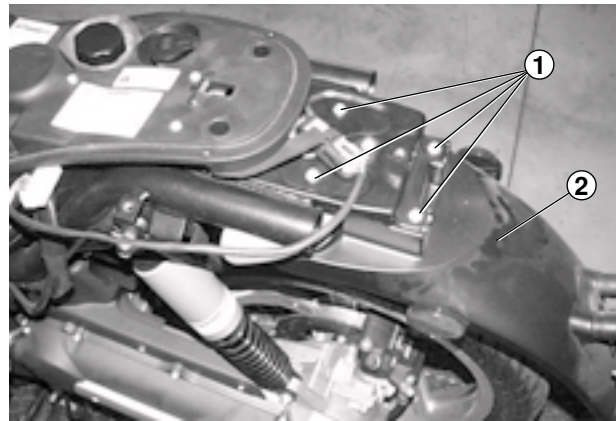

REMOVING THE FOOTBOARD

Carefully read p. 2 (GENERAL SAFETY RULES).

- ◆ Remove the inspection cover, see p. 19 (REMOVING THE INSPECTION COVER).
- ◆ ★Unscrew and remove the four screws (3).
- ◆ Remove the 4 screws (4) from the bottom.

▲ CAUTION

Proceed with care.

Do not damage the tabs and/or the slots in which they fit.

- ◆ Slightly raise the rear part of the footboard and withdraw it from the base of the inner shield.

▲ CAUTION

Do not force the lower shield, since it is fixed to the frame by means of two front screws only.

NOTE Upon reassembly, first install the central tabs, then next, the side tabs.

NOTE Before installing the four screws (3), make sure that the holes in the footboard and the screw seats are aligned.

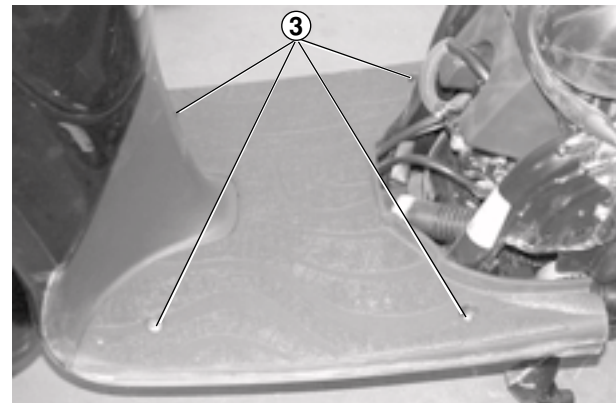

REMOVING THE LOWER SHIELD

Carefully read p. 2 (GENERAL SAFETY RULES).

- ◆ Place the vehicle on the center stand.

▲ WARNING

Before carrying out the following operations, let the engine and the exhaust silencer cool down until they reach room temperature, in order to avoid burns.

- ◆ After removing the footboard, remove the four screws (5) on the bottom part of the vehicle.

▲ CAUTION

Proceed with care.

Do not damage the tabs and/or the slots in which they fit.

- ◆ Withdraw the lower shield (6) from behind.
- ◆ Remove the lower shield (6) completely.

NOTE Upon reassembly, make sure that the front part of the lower shield is correctly positioned.

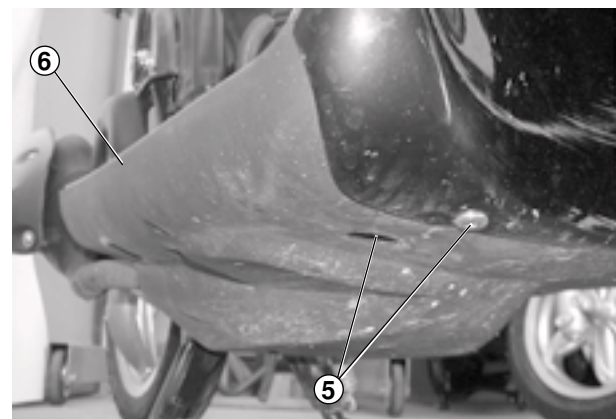
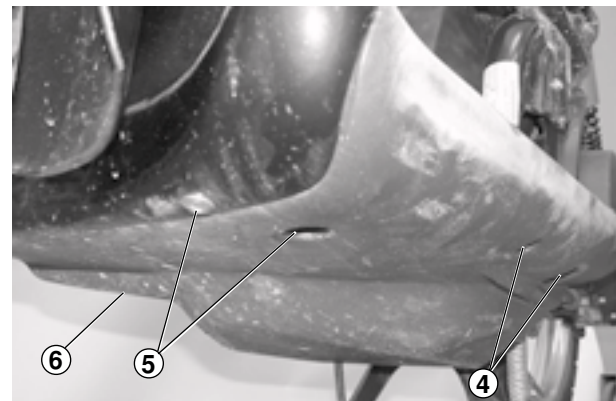

REMOVING THE FRONT COVER

Carefully read p. 2 (GENERAL SAFETY RULES).

- ◆ Place the vehicle on the center stand.
- ◆ Unscrew and remove the one screw (1).

▲ CAUTION

Proceed with care.

Do not damage the tabs and/or the slots in which they fit.

Handle the plastic and painted components with care and avoid scraping or damaging them.

- ◆ Remove the front cover (2), by pulling it downwards.

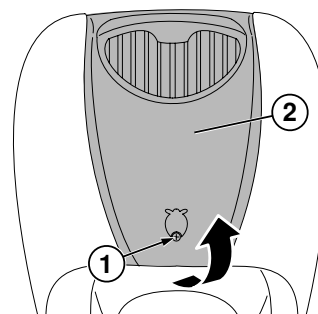

REMOVING THE FRONT INNER SHIELD

Carefully read p. 2 (GENERAL SAFETY RULES).

NOTE Remove the key from the ignition switch.

- ◆ Remove the footboard, see p. 20 (REMOVING THE FOOTBOARD).
- ◆ Remove the lower shield, see p. 20 (REMOVING THE LOWER SHIELD).
- ◆ Remove the rubber gasket (3) from the ignition switch.
- ◆ ★ Unscrew and remove the two screws (4).
- ◆ Open the cover (5) of the glove compartment.
- ◆ Unscrew and remove the screw (6).
- ◆ Remove the front cover, see above (REMOVING THE FRONT COVER).
- ◆ Unscrew and remove the two screws (7).
- ◆ Press the sides of the front outer shield in correspondence with the arrows (A), (B), (C), and pull it, releasing the tabs from their slots.

▲ CAUTION

Proceed with care.

Do not damage the tabs and/or the slots in which they fit.

Handle the plastic and painted components with care and avoid scraping or damaging them.

- ◆ Remove the front inner shield (8).

NOTE Upon reassembly, make sure that the tabs are correctly inserted.

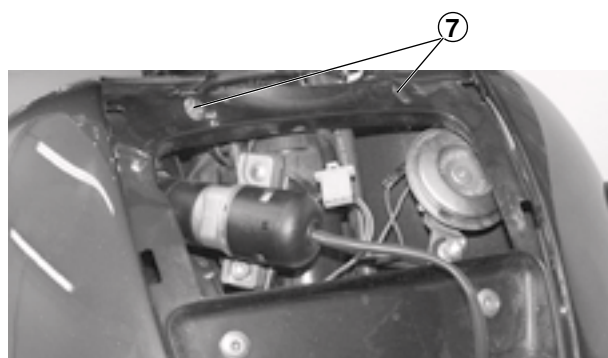
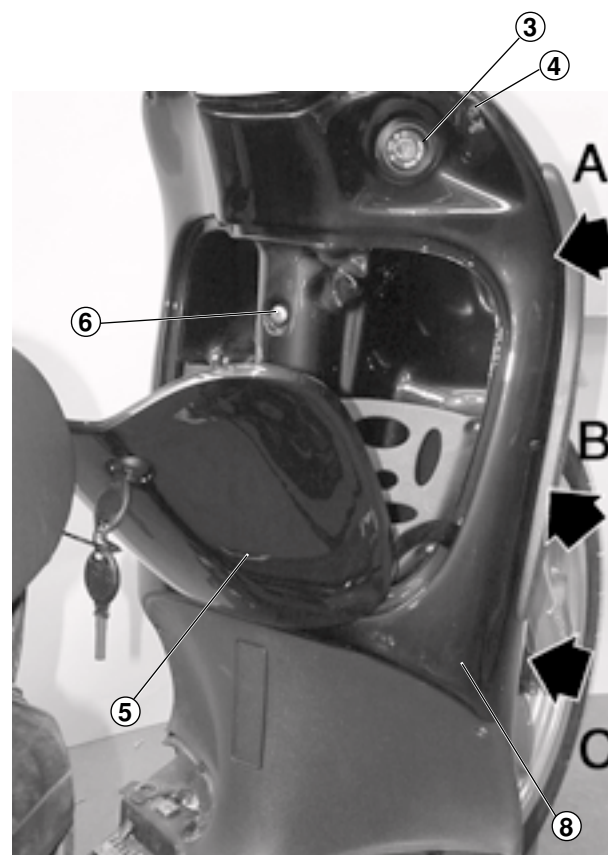

REMOVING THE REAR-VIEW MIRRORS

Carefully read p. 2 (GENERAL SAFETY RULES).

The following information refers to one rear-view mirror only, but is valid for both.

- ◆ Place the vehicle on the center stand.
- ◆ Pull back the rubber boot (1) with your fingers.

▲ CAUTION

Hold the rear-view mirror (2) carefully, so that it is not accidentally dropped.

- ◆ Using two appropriate wrenches, hold the special bolt (3) from rotating and loosen and completely unscrew the nut (4).
- ◆ Remove the rear-view mirror (2).

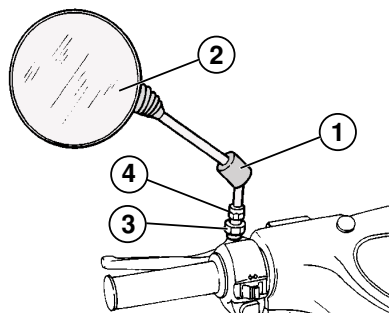

REMOVING THE FRONT HANDLEBAR COVER

Carefully read p. 2 (GENERAL SAFETY RULES).

- ◆ Place the vehicle on the center stand.
- ◆ Unscrew and remove the two screws (5).
- ◆ Unscrew and remove the two screws (6).

▲ CAUTION

Proceed with care in order not to damage the slot (7) which takes tab (8).

- ◆ ★Using a small blade screwdriver, lift the tab (8) positioned inside the front handlebar cover (9).
- ◆ ★Repeat the operation described above on the lower part of the handlebar cover.

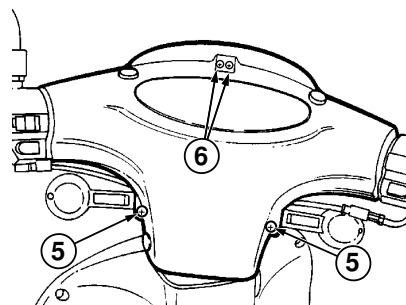

▲ CAUTION

Handle the plastic and painted components with care and avoid scraping or damaging them.

- ◆ Remove the front handlebar cover (9), taking care not to break the tangs.

NOTE Upon reassembly, make sure that the tabs are correctly inserted.

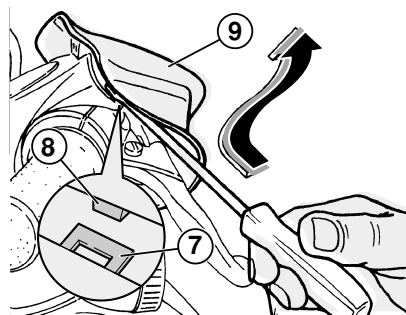

REMOVING THE REAR HANDLEBAR COVER

Carefully read p. 2 (GENERAL SAFETY RULES).

- ◆ Remove the front handlebar cover, see p. 22 (REMOVING THE FRONT HANDLEBAR COVER).
- ◆ Disconnect the two electric connectors of the direction indicators (1).
- ◆ Unscrew the metal ring (2) and withdraw the speedometer / odometer cable (3) from the coupling.
- ◆ Unscrew and remove the three screws (4).
- ◆ Supporting the handlebar cover (5), disconnect the connectors (6).
- ◆ Remove the rear handlebar cover (5).

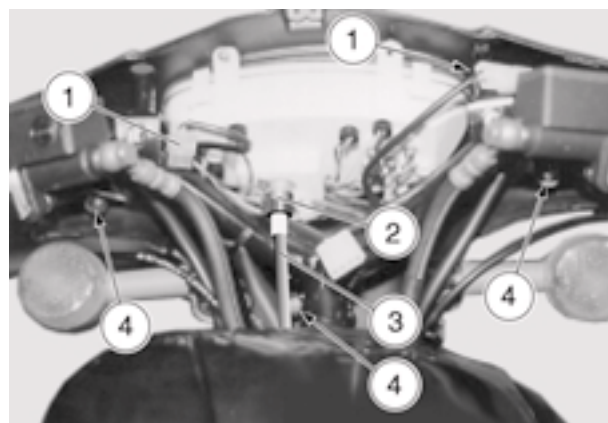

REMOVING THE FRONT OUTER SHIELD

Carefully read p. 2 (GENERAL SAFETY RULES).

- ◆ Remove the complete fork, see p. 58 (REMOVING THE COMPLETE FORK).
- ◆ Remove the front cover, see p. 21 (REMOVING THE FRONT COVER).
- ◆ Unscrew and remove the two upper screws (8).
- ◆ Remove the front outer shield (9).

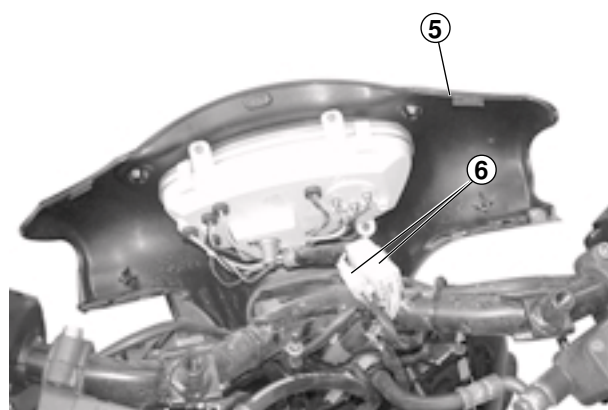

REMOVING THE BUMPER

Carefully read p. 2 (GENERAL SAFETY RULES).

- ◆ To remove the bumper, after first removing the front inner shield, remove the six clips (10) on each side.

NOTE Use new clips to refit the bumper.

REMOVING THE FRONT MUDGUARD

Carefully read p. 2 (GENERAL SAFETY RULES).

- ◆ Remove the complete fork, see p. 58 (REMOVING THE COMPLETE FORK).
- ◆ Remove the two screws (12).
- ◆ Hold the screw (13) from rotating with an appropriate Allen wrench.
- ◆ Remove the nut (14).

NOTE Upon reassembly, position the nut (13) correctly.

- ◆ Remove the front mudguard (15).

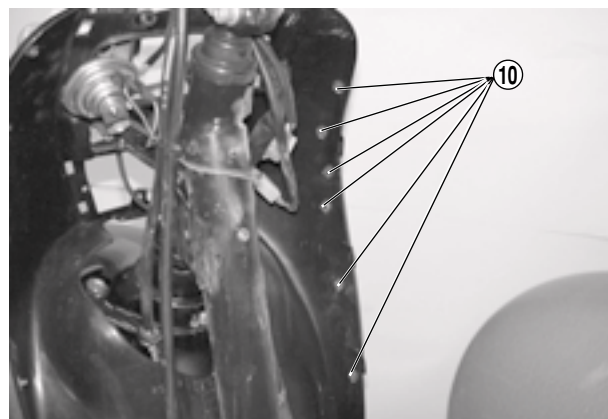
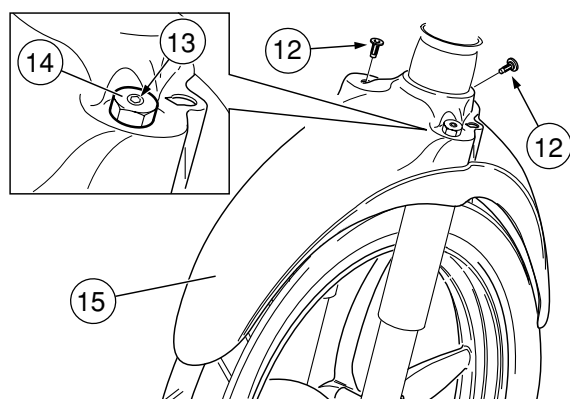
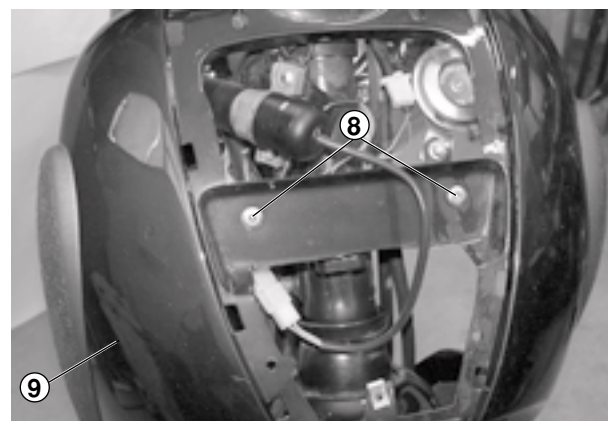

REMOVING THE SADDLE SUPPORT

Carefully read p. 2 (GENERAL SAFETY RULES).

- ◆ Remove the rear part of the fairing, see p. 19 (REMOVING THE REAR PART OF THE FAIRING).
- ◆ Remove the battery as described on page 63 (BATTERY STORAGE).
- ◆ Detach the fuse strip (1) and the two dampers (2) and (3) from their supports by passing them through the slot as shown in the figure.
- ◆ ★Unscrew and remove the 4 screws (4).
- ◆ Unscrew and remove the filler cap (5).
- ◆ Remove the cap of the 2 stroke oil tank (6).
- ◆ Disconnect the fuel breather pipe (7) from the fuel tank.
- ◆ Disconnect the drainage pipe (9) from the fuel bowl (8).
- ◆ Remove the fuel bowl (8).

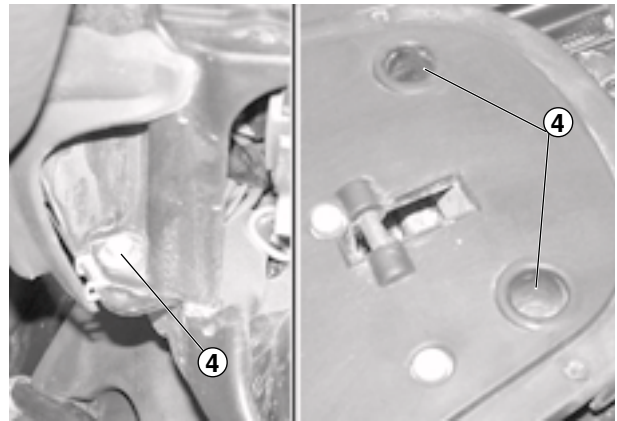

NOTE Disconnect the electric connection of the central control unit and of the pressure sensor (12).

- ◆ Pass the cabling, complete with relay switches and fuse block through the slot in the front of the saddle support.
- ◆ Lift the front section of the saddle support (11), slide it forward and remove it.

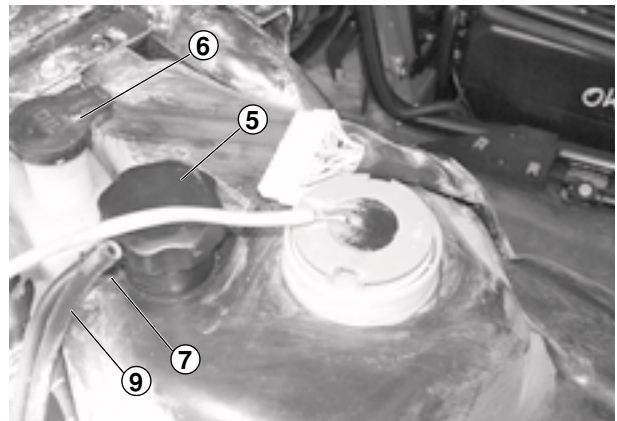

NOTE When reassembling the saddle support (11), before positioning it in its seat, refit the fuel bowl (8) correctly and connect it to the drainage pipe (9).

- ◆ Screw on the filler cap (5) and return the 2 stroke oil tank cap (6) to its correct position.

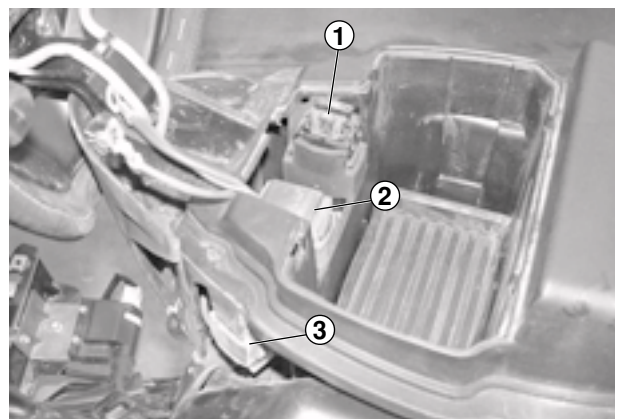
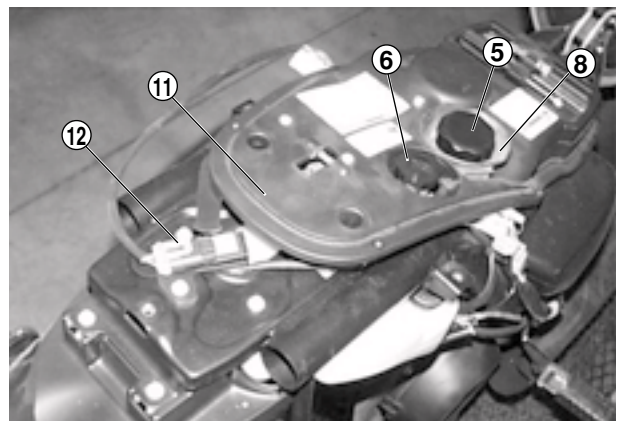

FUEL TANK

Carefully read p. 2 (GENERAL SAFETY RULES).

FUEL**▲ WARNING**

Gasoline is extremely flammable and in some conditions can become explosive.

Therefore, it is necessary to refuel and carry out maintenance operations involving the fuel system in a well-ventilated area with the engine off.

Do not refuel or do any maintenance on the fuel system with the engine running.

Do not smoke while refueling or near fuel vapors.

Never allow any portion of the fuel system to come in contact with naked flames, sparks or other heat sources. Be careful to avoid spilling fuel when you are refueling. Spilled fuel could ignite when it contacts hot engine or exhaust system surfaces. If you accidentally spill some fuel, make sure that it is wiped up or completely evaporated before starting the vehicle.

Since gasoline expands in the fuel tank when the vehicle is sitting in the open sun, never fill the tank completely to the brim. Leave at least one inch of expansion space.

Avoid any contact of the fuel with your skin, and avoid inhalation of fuel vapors. Do not ever attempt to siphon fuel from one container to another using your mouth as suction for a siphon hose.

▲ WARNING

Gasoline is poisonous and carcinogenic and contains chemical substances that cause birth defects and other reproductive problems. If gasoline should be accidentally spilt on the skin or clothes, immediately wash it off with soap and water and change clothes.

Should you accidentally spill gasoline in your eyes, flush with a large quantity of water and immediately contact a health professional. Should you accidentally get gasoline into your mouth, do not induce vomiting. Drink a large quantity of milk or clear water and immediately contact a health professional.

Never try to siphon gasoline by sucking it with your mouth. Use a manual pump or a similar system.

If your vehicle overturns, it will leak gasoline which is extremely flammable. Flames or sparks may ignite this which will not only destroy the vehicle but also could do serious property damage to surrounding property and cause serious injuries or even death.

ALWAYS KEEP GASOLINE AWAY FROM CHILDREN.

DISPOSE OF UNWANTED GASOLINE PROPERLY, DO NOT DUMP IT INTO STORM SEWERS OR INTO A SINK OR TOILET.



DRAINING THE FUEL TANK

Carefully read p. 25 (FUEL TANK).

BE SURE TO KEEP THE DRAINED FUEL AWAY FROM CHILDREN.

- ◆ Place the vehicle on the center stand.
- ◆ Stop the engine and wait until it has cooled down.
- ◆ Prepare a container with capacity exceeding the fuel quantity present in the tank and put it on the ground on the left side of the vehicle.
- ◆ Remove the filler cap.
- ◆ Empty the fuel tank by means of a manual pump or a similar system.
- ◆ Use the fuel delivery pipe sleeve fitted to the fuel flange.

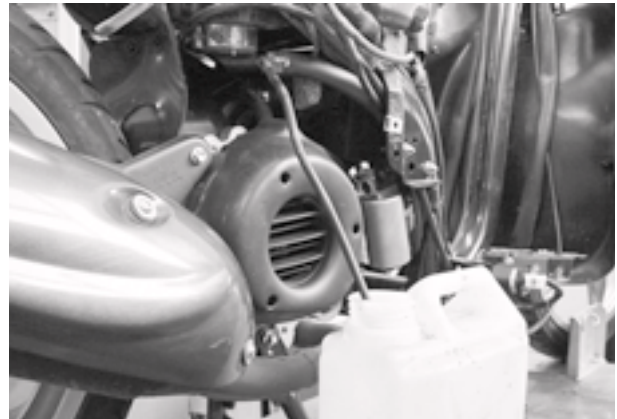

▲ WARNING

After draining the tank, replace the filler cap in correct position.

REMOVING THE FUEL FLANGE

Carefully read p. 25 (FUEL TANK).

- ◆ Drain the fuel tank completely (see above paragraph).
- ◆ Disconnect the three fuel delivery, return and breather pipes from the flange.



▲ CAUTION

On reassembly, use new clamps for the fuel delivery and return pipes.

- ◆ Unscrew the clamp (1) and remove the flange.
- ◆ On reassembly, take care to position the flange correctly on the tank.

CLEANING THE FUEL FILTER

Carefully read p. 25 (FUEL TANK).

- ◆ Remove the fuel flange as described previously.
- ◆ Remove the filter (3) from the flange (2) and clean it with compressed air. Refit the filter.

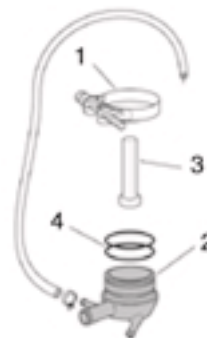

CHECKING THE FUEL LEVEL GAUGE UNIT

For the checking of the fuel level gauge unit, see p. 80 (FUEL LEVEL INDICATOR).

REMOVING THE FUEL LEVEL GAUGE UNIT

Carefully read p. 25 (FUEL TANK).

- ◆ Remove the saddle support, see p. 24 (REMOVING THE SADDLE SUPPORT).
- ◆ Disconnect the electric connector of the fuel level gauge unit (5).

NOTE Upon reassembly, position the electric cable of the fuel level gauge unit in the appropriate seat in the fuel tank.

▲ CAUTION

Handle with care.

Avoid damaging the gauge unit during the removal.

- ◆ Rotate the fuel level gauge unit (6) counterclockwise and withdraw it.

▲ WARNING

Tape the gauge unit hole on the tank shut with masking tape to avoid contaminating the tank with dust or other foreign matter.

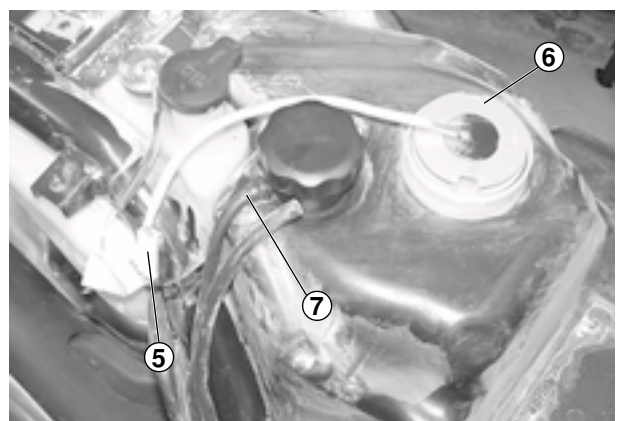

REMOVING FUEL TANK

Carefully read p. 25 (FUEL TANK).

- ◆ Drain the fuel tank completely, see p. 26 (DRAINING THE FUEL TANK).
- ◆ Remove the fuel flange from the tank.
- ◆ Disconnect the electric connector of the fuel level gauge unit.
- ◆ Remove the saddle support, see p. 24 (REMOVING THE SADDLE SUPPORT).

▲ CAUTION

Handle with care.

Do not force tubes or cables.

- ◆ Remove the fuel breather pipe (7), see the figure on page 26.
- ◆ Unscrew the screws (2) and (3) and lift the entire fuel tank with care.
- ◆ Remove the three screws (4) to free the tank from the rear protection flap.

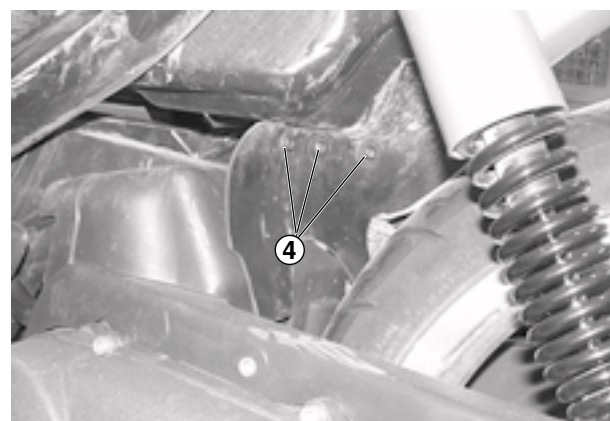

2 STROKE OIL TANK

Carefully read p. 2 (GENERAL SAFETY RULES).

⚠ CAUTION

Carefully wash your hands after handling the oil.
Dispose of the oil properly.

KEEP OIL AWAY FROM CHILDREN.

⚠ WARNING

If you should run the 2 stroke oil tank dry, the engine will seize. This could cause an upset, or other accident, with subsequent serious injury or even death.

CHECKING

Carefully read above (2 STROKE OIL TANK).

CHECKING THE 2 STROKE OIL LEVEL GAUGE UNIT

- ◆ Remove the saddle support, see p. 24 (REMOVING THE SADDLE SUPPORT).

⚠ CAUTION

Handle with care.

Do not force tubes or cables.

- ◆ Remove the 2 stroke oil level gauge unit (1).
- ◆ Verify the efficiency of the 2 stroke oil level gauge unit (1), p. 79 (CHECKING THE 2 STROKE OIL LEVEL SENSOR).

CHECKING THE 2 STROKE OIL FILTER

- ◆ Empty the 2 stroke oil tank completely, see below (DRAINING).
- ◆ Check, and if necessary, wash the filter (2), and the filtering element with a fireproof solvent, removing all deposits and foreign matter.

DRAINING

Carefully read above (2 STROKE OIL TANK).

- ◆ Remove the rear part of the fairing, see p. 19 (REMOVING THE REAR PART OF THE FAIRING).
- ◆ Remove the section below the saddle, see (REMOVING THE SECTION BELOW THE SADDLE).
- ◆ Remove the tank cap (3).
- ◆ Place a container of at least 2.11 US qt (2 ℓ) capacity under the filter coupling to catch the oil.
- ◆ Cut the hose clamp (4) which attaches the hose to the filter (2) and remove.

NOTE Upon reassembly, this clamp will be replaced with a screwdriver type worm clamp of the appropriate size. This clamp may be obtained from local sources.

- ◆ Disconnect the filter (2) from the 2 stroke oil tank (5).

⚠ CAUTION

Position and tie the filter (2) vertically, so that the residual oil left in the tube (6) cannot flow out.

- ◆ Put all the drained oil in an appropriate container, close it and store it in a safe place.

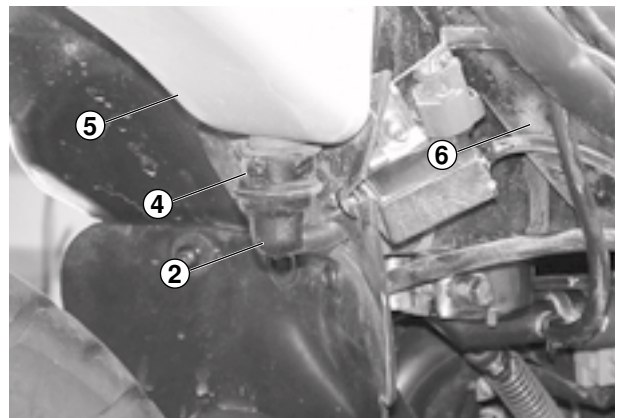
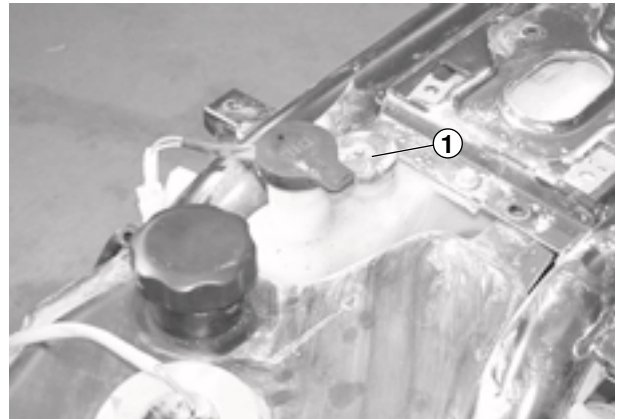

REMOVAL

Carefully read p. 30 (2 STROKE OIL TANK)

- ◆ Remove the saddle support, see p. 24 (REMOVING THE SADDLE SUPPORT).
- ◆ Drain the 2 stroke oil tank (1) completely, see p. 30 (DRAINING).
- ◆ Disconnect the electric connector (2) of the 2 stroke oil level gauge (3).
- ◆ Remove the support screws (4) of the 2 stroke oil tank.
- ◆ Remove the 2 stroke oil tank (1).

▲ CAUTION

Upon reassembly, fill the tank and bleed the 2 stroke oil, see below (BLEEDING THE 2 STROKE OIL TANK).

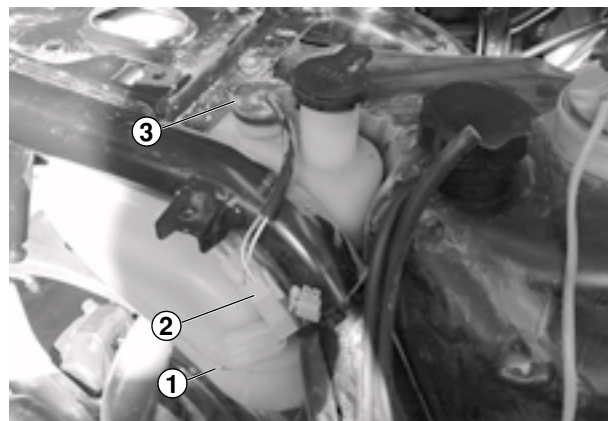

BLEEDING THE 2 STROKE OIL TANK

Carefully read p. 28 (2 STROKE OIL TANK).

NOTE Bleed the 2 stroke oil system whenever the 2 stroke oil tank is completely empty or the oil supply pipe is disconnected to remove the tank.

▲ CAUTION

Carefully wash your hands after handling the oil. Dispose of the oil properly.

BE SURE TO KEEP THE DRAINED OIL AWAY FROM CHILDREN.

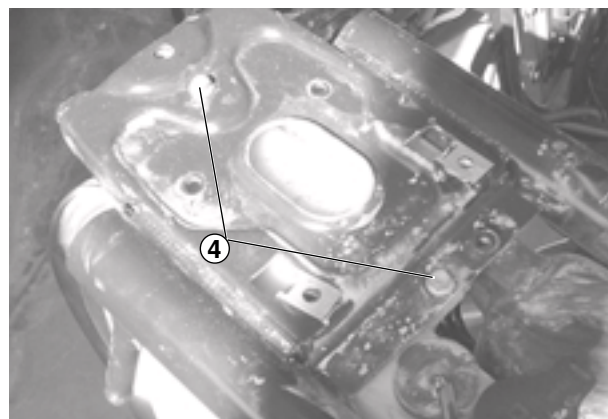

- ◆ Place the vehicle on the center stand.
- ◆ Fill the 2 stroke oil tank completely.
- ◆ Carry out the automatic bleeding procedure as follows:
 - Turn the acceleration handlebar to the end of its travel with the key removed.
 - Keeping the acceleration handlebar turned, turn the key to the "ON" position.
 - This situation (acceleration turned – key at "ON") must be maintained until you hear a click (sound) from the oil pump (5) or until you see the oil moving through the oil delivery pipe (6), which is transparent.
 - Release the acceleration handlebar; at this point the pump will continue to pump oil.
 - This operation will be completed as soon as there are no longer any air bubbles inside the pipe.
 - At this point, the lubrication system has been bled.
 - Turn the key back to the "OFF" position.

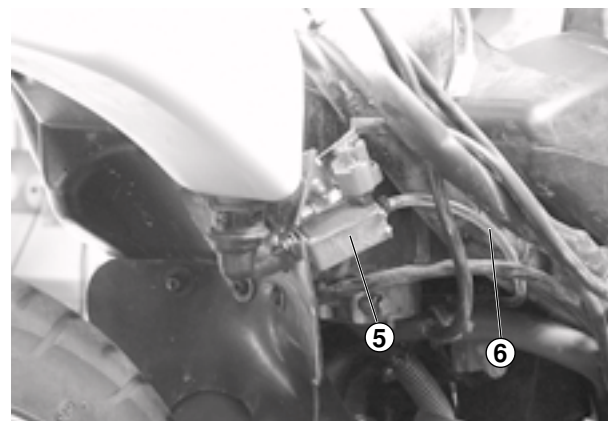

▲ CAUTION

It is important to ensure that no air remains in the line, since running the engine with air in the 2 stroke oil can seriously damage it.

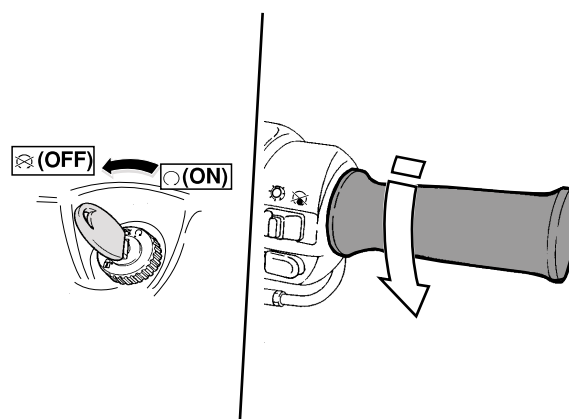

DISASSEMBLING THE OIL PUMP

- ◆ Completely drain the 2 stroke oil tank, as described on page 28 (draining).
- ◆ Disconnect the electric connection (1).
- ◆ Remove the two clamps (2) and (3) from the piping.
- ◆ Remove the oil pump (4) after first unscrewing its support screw from the bottom.

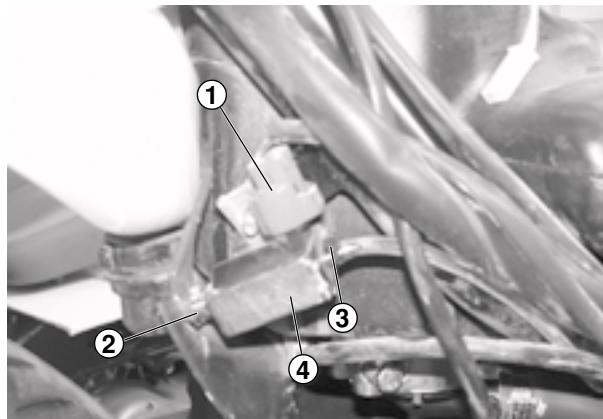

⚠ CAUTION

On reassembly, after filling the tank, carry out the procedures for automatic bleeding, as described previously.

REMOVING THE PASSENGER FOOTBOARDS

- ◆ Position the vehicle on the center stand.
- ◆ Remove the inspection cover, see (REMOVING THE INSPECTION COVER).
- ◆ Loosen and remove the two screws (1) being sure to recover the relevant nuts.
- ◆ Remove the passenger footboard (2) and repeat this procedure for the passenger footboard on the opposite side of the vehicle.

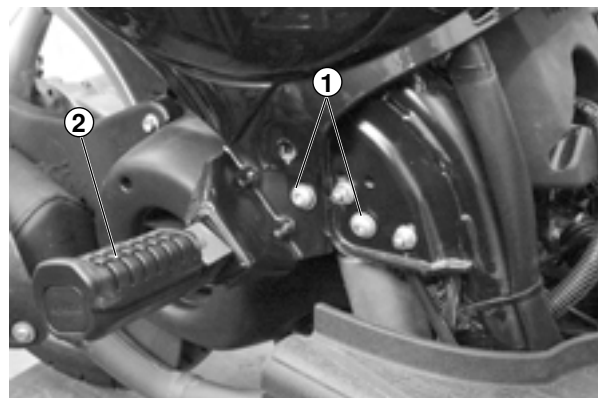

FUEL PUMP

- ◆ Completely drain the fuel tank (see page 26).
- ◆ Disconnect the electric connection (5) on the fuel pump.
- ◆ Remove the two screws (6) that fasten the pump support to the frame.

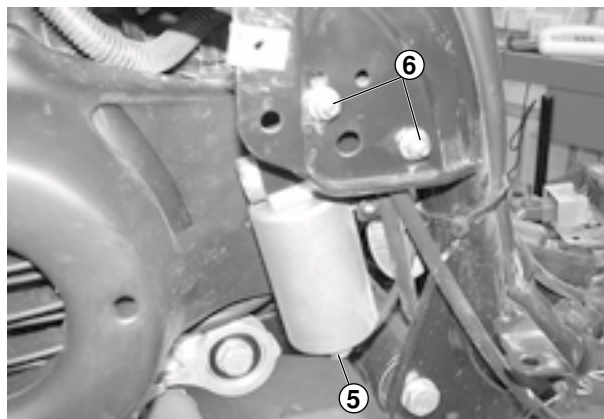

- ◆ Remove the fuel pump from the frame as shown in the figure.
- ◆ Remove the clamps (7) and (8) by pulling the relevant sleeves away from the body of the pump. To replace the pump, free it from its support by removing the two fastening screws (9).

NOTE On reassembly, replace the clamps (7) and (8) with new ones.

⚠ CAUTION

During fuel pump disassembly and reassembly operations, always handle components with care. Never force pipes or cables.

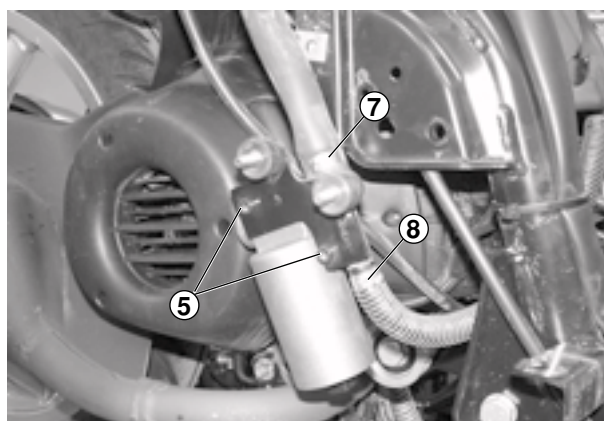

BULBS

Carefully read p. 2 (GENERAL SAFETY RULES).

▲ WARNING

Risk of fire.

Keep fuel and other flammable substances away from the electrical components.

▲ CAUTION

Before changing a bulb, turn the ignition switch to position “⊗” (OFF) (1) and wait a few seconds in order to allow the bulb to cool down. Change the bulb wearing clean gloves or using a clean and dry cloth.

Do not leave fingerprints on the bulb, since these may cause its overheating and consequent breakage.

If you touch the bulb with your bare hands, remove any fingerprints with a clean cotton cloth dampened with alcohol in order to avoid damage.

TAKE CARE TO AVOID DAMAGING THE ELECTRIC CABLES.



HEADLIGHT

ADJUSTING THE HEADLIGHT BEAM VERTICALLY

▲ WARNING

Do not use the vehicle if the lights are not functioning properly.

Do not use the vehicle if the headlight is adjusted incorrectly.

This could temporarily blind oncoming cars, and also reduce the rider's ability to see any obstacle along the road while riding at night.

It is always advisable to reduce speed when riding during the night, in such a way as to have the time necessary to avoid any obstacle and to adapt to the poorer visibility that inevitably results from darkness.

Failure to observe this warning can cause you to collide with another object, with consequent risk of serious injury or even death.

NOTE The procedure described here is in compliance with the Italian standard that establishes the maximum height of the headlight beam.

For vehicles used in other countries, you must conform with the local regulations.

To quickly check the aiming of the beam, place the vehicle on flat ground, **32.81 ft (10 m)** away from a wall. Turn on the low beam, sit on the vehicle and make sure that the beam projected on the wall is slightly under the horizontal line of the headlight (about 9/10th of the total height).

To adjust the headlight beam:

- ◆ Adjust screw (2) with a screwdriver.
 - Turn the screw clockwise to adjust the beam higher.
 - Turn the screw counterclockwise to adjust the beam lower.

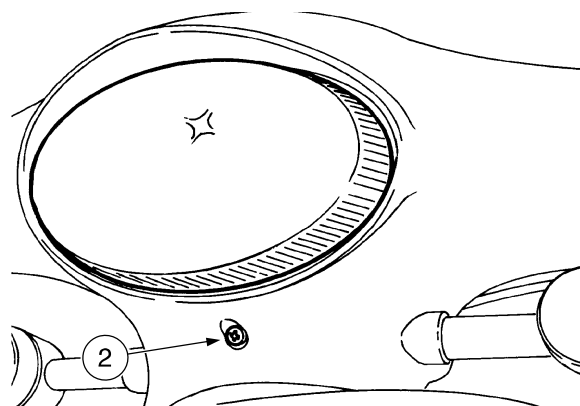
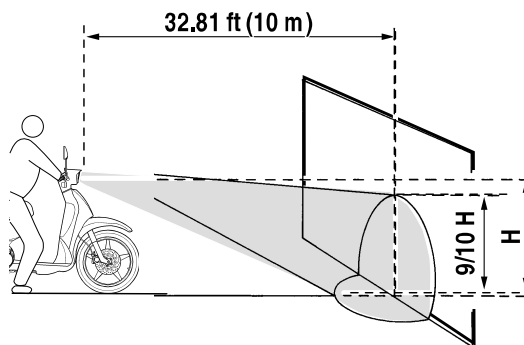
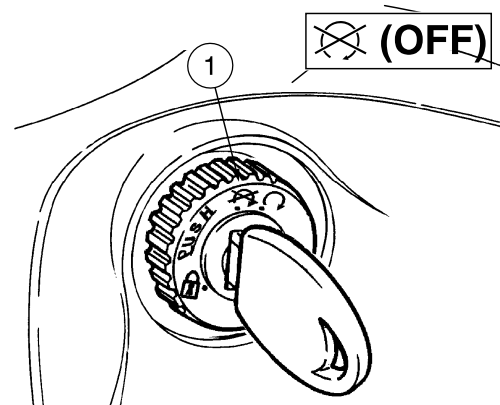

ADJUSTING THE HEADLIGHT BEAM HORIZONTALLY

NOTE The terms “right” and “left” are referred to the rider seated on the vehicle in the normal riding position. It is possible to adjust the horizontal position both to the right and to the left.

To adjust the beam:

- ◆ Remove the front handlebar cover, see p. 22 (REMOVING THE FRONT HANDLEBAR COVER).

▲ CAUTION

Handle with care.

Take care not to damage the electric wires.

NOTE Do not completely unscrew nor remove the screws (1) and (2).

- ◆ Loosen the screws (1) and (2).

Once the screws (1) and (2) are loose, you may adjust the beam to the left and right as you wish. Proceed very carefully, as follow:

- ◆ To adjust the beam to the right, apply force as shown in figure **A**. Push on screw (1) and pull on screw (2).
- ◆ To adjust the beam to the left, apply force as shown in figure **B**. Pull on screw (1) and push on screw (2).

▲ CAUTION

Tighten the screws (1) and (2) with care.

- ◆ When you are satisfied with the adjustment, tighten the screws snugly. Do not overtighten.
- ◆ Replace the front handlebar cover, see p. 22 (REMOVING THE FRONT HANDLEBAR COVER).
- ◆ Make sure that the horizontal adjustment of the headlight beam is correct.
- ◆ Make sure that the vertical adjustment of the headlight beam is correct, see p. 31 (ADJUSTING THE HEADLIGHT BEAM VERTICALLY).

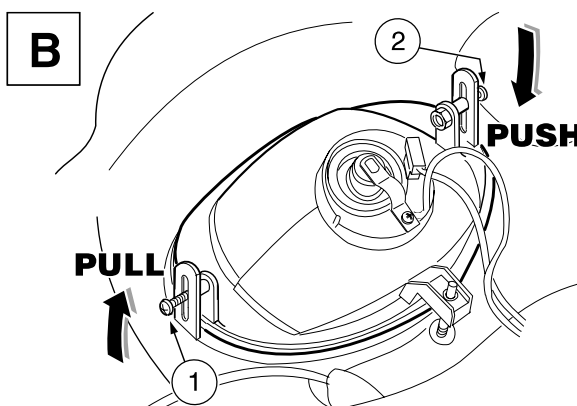
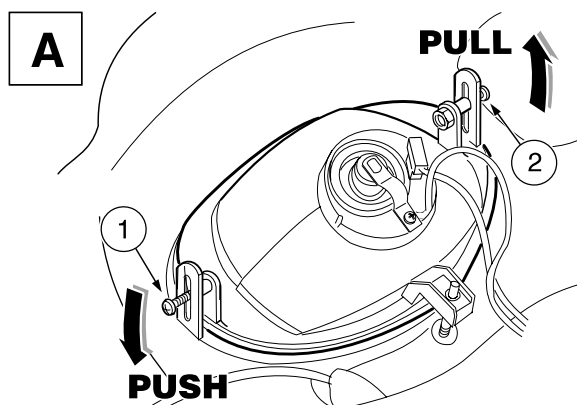
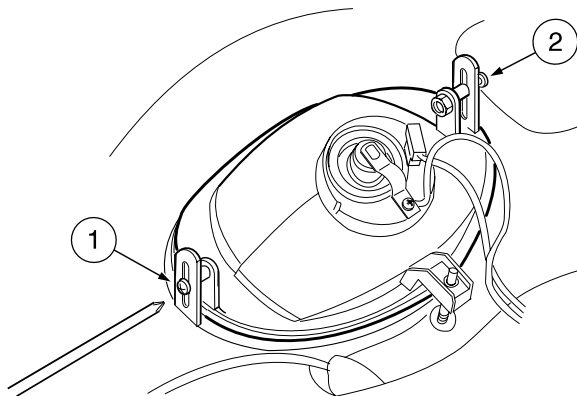

CHANGING THE HEADLIGHT BULBS

Carefully read p. 31 (BULBS).

The headlight contains:

- one low/high beam bulb (1).

To change the bulb:

LOW/HIGH BEAM BULB

- ◆ Remove the front handlebar cover, see p. 22 (REMOVING THE FRONT HANDLEBAR COVER).
- ◆ Rotate the bulb socket (2) counterclockwise and remove it.
- ◆ Push the bulb (1) toward the back of the socket lightly, and rotate it counterclockwise.
- ◆ Remove the bulb from the seat.

NOTE Be sure to maintain the same orientation as the old bulb when you install the new bulb. Do not force the bulb, it will go easily if it is properly oriented.

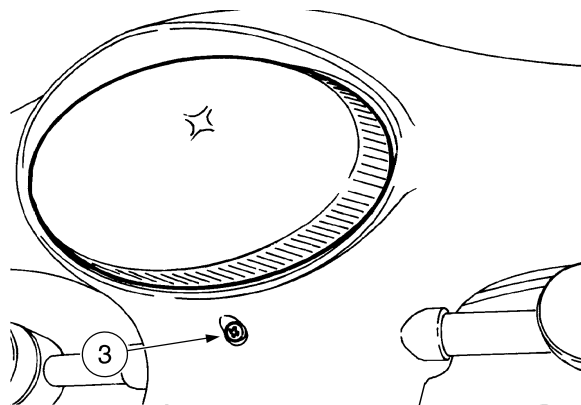

REMOVING THE HEADLIGHT

▲ WARNING

Risk of fire.

Keep fuel and other flammable substances away from the electrical components.

- ◆ Remove the front handlebar cover, see p. 22 (REMOVING THE FRONT HANDLEBAR COVER).
- ◆ Unscrew and remove the screw (3), remove the spring (4).

NOTE Upon reassembly, make sure that the light beam is adjusted correctly, see p. 31 (ADJUSTING THE HEADLIGHT BEAM VERTICALLY) and p. 32 (ADJUSTING THE HEADLIGHT BEAM HORIZONTALLY)

NOTE Observe the arrangement of the components (6) (7) (8), in order to be able to reassemble them correctly.

- ◆ ★Unscrew and remove the screw (5).
- ◆ ★Extract the insert (6) and retrieve the nut (7).

NOTE Upon reassembly correctly insert the insert (6) in the spacer ring (8) and successively insert the nut (7) in the insert (6).

- ◆ ★Remove the spacer ring (8).

NOTE Upon reassembly correctly insert the teeth (9) of the spacer ring (8) in the support slot (10).

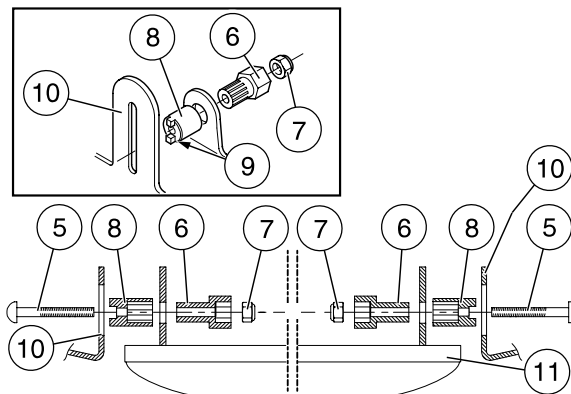
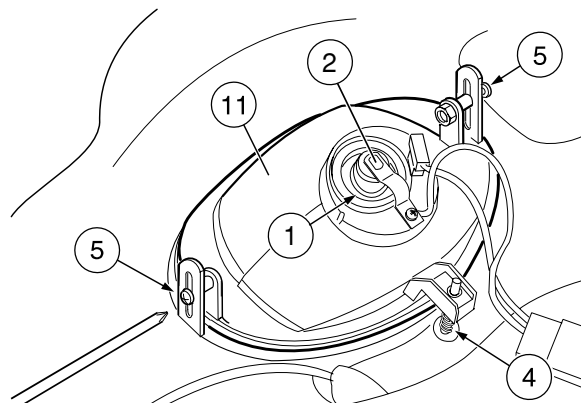

▲ CAUTION

Proceed with care.

Do not damage the headlight lens.

- ◆ Remove the headlight (11) complete with the bulb socket.

FRONT AND REAR DIRECTION INDICATORS**CHANGING THE BULB**

Carefully read p. 31 (BULBS).

NOTE Before changing a bulb, check the fuse.

To change the bulb:

- ◆ Place the vehicle on the center stand.
- ◆ Unscrew and remove the screw (1).

NOTE While removing the lens, use extra care to be sure that you do not break the key.

- ◆ Remove the lens (2).

NOTE Upon reassembly, position the lens correctly in its seat.

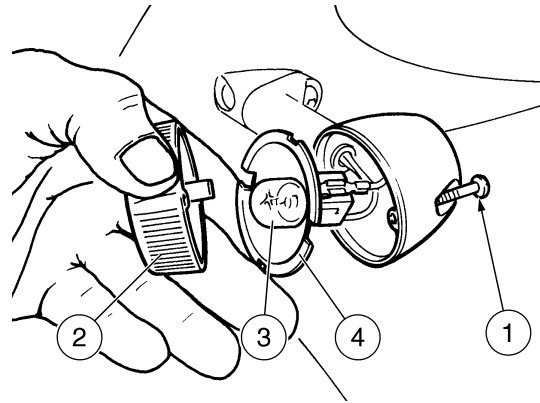
**▲ CAUTION**

Tighten the screw (1) moderately and with care to avoid damaging the lens.

- ◆ Push the bulb (3) in slightly and rotate it counterclockwise.
- ◆ Extract the bulb from its seat.

NOTE Insert the bulb in the bulb socket, carefully aligning the two bulb pins with their guides in the socket.

- ◆ Correctly install a new bulb of the same type.

NOTE If the bulb socket (4) has fallen out of its seat, replace it correctly, ensuring that the slot in the reflector aligns with the screw hole in the body of the turn signal lamp.

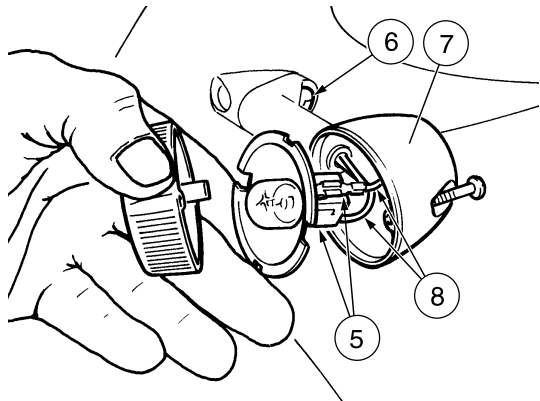
**REMOVING THE COMPLETE DIRECTION INDICATOR****▲ WARNING**

Risk of fire.

Keep fuel and other flammable substances away from the electrical components.

- ◆ Place the vehicle on the center stand.
- ◆ Unscrew and remove the screw (1).

NOTE While removing the lens, use extra care to be sure that you do not break the key.

- ◆ Remove the lens (2).

NOTE Upon reassembly, position the lens correctly in its seat.

▲ CAUTION

Tighten the screw (1) moderately and with care to avoid damaging the lens.

▲ CAUTION

Do not leave fingerprints on the bulb, since these may cause its overheating and consequent breakage.

If you touch the bulb with your bare hands, remove any fingerprints with a clean cotton cloth dampened with alcohol in order to avoid damage.

TAKE CARE TO AVOID DAMAGING THE ELECTRIC CABLES.

- ◆ Extract the bulb socket (4) as much as necessary to disconnect the two electric terminals (5).
- ◆ Disconnect the two electrical terminals (5) and remove, completely, the bulb socket (4).

NOTE Upon reassembly, correctly replace the bulb socket, ensuring that the slot in the reflector aligns with the screw hole in the body of the turn signal lamp.

- ◆ Unscrew the screw (6).
- ◆ Remove the indicator support (7) and withdraw it from the cables (8).

REAR LIGHT**REPLACING THE REAR LIGHT BULB**

Carefully read p. 31 (BULBS).

- ◆ Position the vehicle on the stand.
- ◆ Unfasten and remove the two screws (1).

NOTE Take great care when removing the protective cover, so that you do not break the coupling tooth.

- ◆ Remove the protective cover (2)
- ◆ Press the bulb moderately and turn it in an anti-clockwise direction.
- ◆ Remove the bulb from its holder.

NOTE When inserting the bulb in the holder, make sure that the two guide pins coincide with the respective slots on the holder.

- ◆ Install a bulb of the same type in the correct manner.

NOTE When reassembling, make sure the protective cover is correctly positioned in its housing. Tighten the screws (6) carefully and without using undue force, to prevent damage to the protective cover.

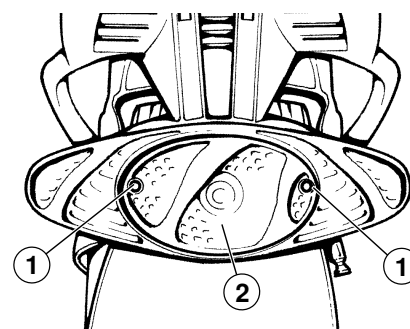
**REPLACING REAR DIRECTION INDICATOR LAMP BULBS**

Carefully read p. 31 (BULBS).

- ◆ Position the vehicle on the stand.
- ◆ Unfasten and remove the two screws (1).

NOTE Take great care when removing the protective cover, so that you do not break the coupling tooth.

- ◆ Remove the protective cover (2).

NOTE When reassembling, make sure the protective cover is correctly positioned in its housing.

- ◆ Remove the protective cover (3), opening it towards the outside of the vehicle.
- ◆ Press the amber element (4) moderately, turn it in an anti-clockwise direction and extract it.

NOTE Take great care when removing the protective cover, so that you do not break the coupling tooth.

- ◆ Press the bulb (5) moderately and turn it in an anti-clockwise direction.
- ◆ Extract the bulb (5) from its housing.

NOTE When inserting the bulb in the holder, make sure that the two guide pins coincide with the respective slots on the holder.

- ◆ Install a bulb of the same type in the correct manner.

NOTE If the bulb holder (6) comes out of its housing, replace it properly so that the flared opening on the bulb holder coincides with the screw housing.

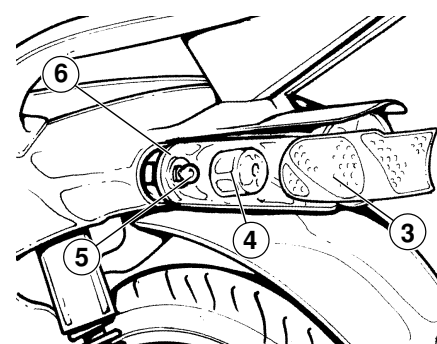
**REMOVING THE REAR LIGHT****▲ CAUTION**

Handle with care.

Do not force the electric cables.

- ◆ Remove the 4 screws (7) shown in the figure.
- ◆ Take the light unit, complete with cabling, out from the opposite side.

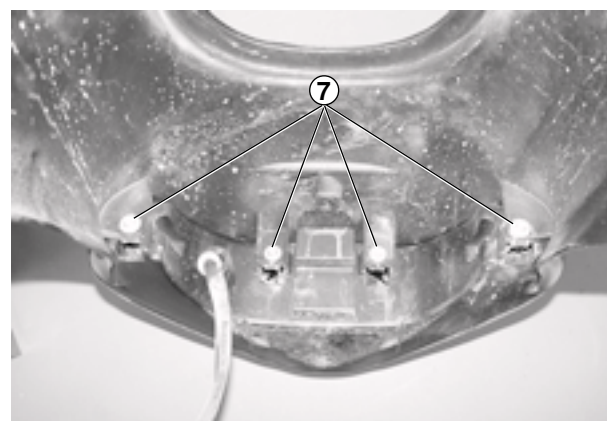

NUMBER PLATE LAMP BULB

REPLACING NUMBER PLATE LAMP BULB

Carefully read p. 31 (BULBS).

To replace:

- ◆ Unfasten and remove the screw (1).
- ◆ Extract the rubber bulb holder (2).
- ◆ Remove the bulb from its housing.
- ◆ Install a bulb of the same type in the correct manner, following the above procedure in reverse order.

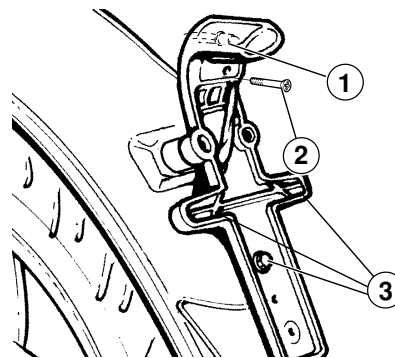

CAUTION

Do not pull on the wires to extract the bulb holder.

NOTE When reassembling, make sure that the bulb holder is properly inserted into its housing.

REMOVING THE NUMBER PLATE LAMP

Carefully read p. 31 (BULBS).

- ◆ To replace the number plate lamp, it is necessary to remove the three screws (3).
- ◆ Disconnect the relevant electric connection.

DASHBOARD

CHANGING THE DASHBOARD BULBS

Carefully read p. 31 (BULBS).

NOTE Before changing a bulb, check the fuses.

The dashboard contains:

- the warning light bulbs;
- the dashboard lighting bulbs.

To change the bulbs:

- ◆ Remove the front handlebar cover, see p. 22 (REMOVING THE FRONT HANDLEBAR COVER).

WARNING LIGHT BULBS

NOTE Extract the bulb sockets one by one, in such a way as to avoid positioning them incorrectly during the reassembly.

- ◆ Extract the appropriate bulb socket:

Pos.	Warning light	Colour
1	Direction indicators (↔)	green
2	2 stroke oil reserve (⚡)	red
3	High beam (≡)	blue
4	Injection check	red

Extract the bulb and replace it with one of the same type.

DASHBOARD LIGHTING BULBS

NOTE Extract the bulb sockets one by one, in such a way as to avoid positioning them incorrectly during the reassembly.

- ◆ Extract the bulb socket of the dashboard part in which there has been a light decrease:

Pos.	Lit part
5	Upper right part
6	Upper left part (+)
7	Lower right part

- ◆ Extract the bulb and replace it with one of the same type.

(+) Some versions might not have this bulb.

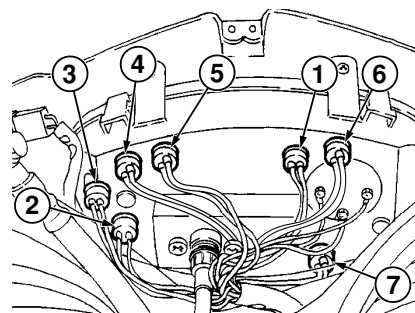
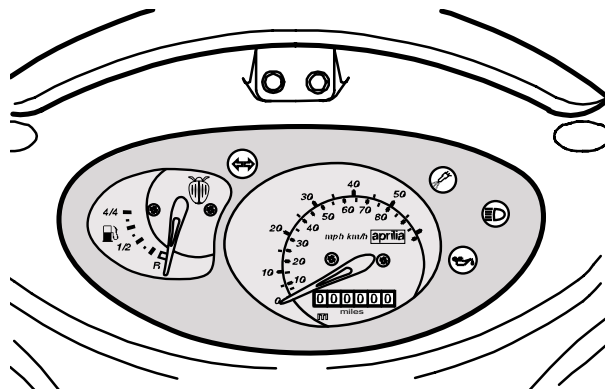

REMOVING THE COMPLETE DASHBOARD

▲ WARNING

Risk of fire.

Keep fuel and other flammable substances away from the electrical components.

- ◆ Remove the front handlebar cover, see p. 22 (REMOVING THE FRONT HANDLEBAR COVER).
- ◆ Unscrew and remove the two screws (1).
- ◆ Unscrew and remove the two screws (2).

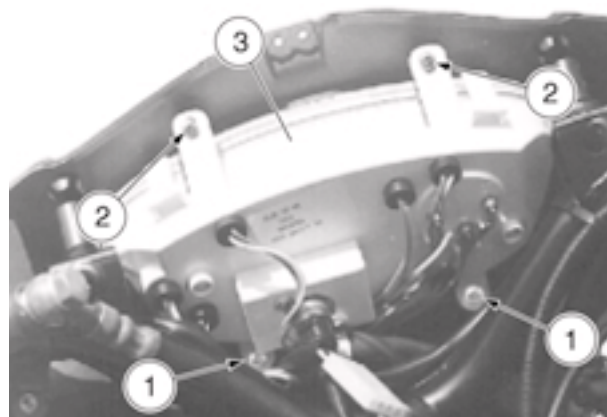

▲ CAUTION

Handle the plastic and painted components with care and avoid scraping or damaging them.

▲ CAUTION

Handle with care.

Do not force the electric cables.

- ◆ Partially remove the dashboard (3).

▲ CAUTION

Support the dashboard, in order to prevent it from accidentally falling down.

- ◆ Disconnect the speedometer/odometer cable (4) from the dashboard.
- ◆ Disconnect the main connector (5).
- ◆ Remove the complete dashboard.

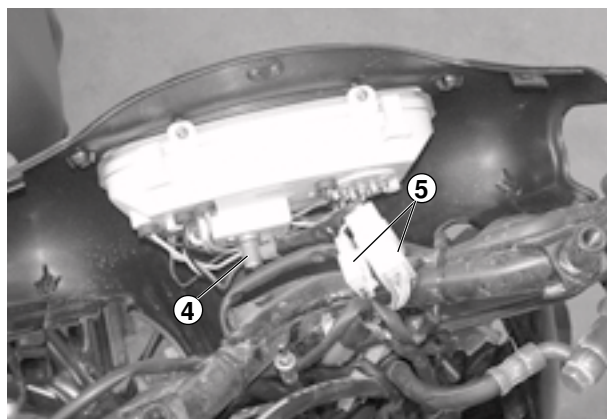

REMOVING THE DASHBOARD TRANSPARENT SCREEN

- ◆ Remove the complete dashboard, see above (REMOVING THE COMPLETE DASHBOARD).

▲ CAUTION

Handle with care.

Upon disassembly and reassembly do not damage the transparent screen and/or the couplings.

- ◆ Press on the four tabs (6) and remove the transparent screen (7).

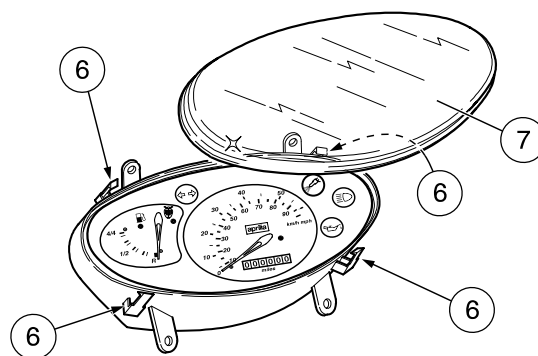

BRAKES**▲ WARNING**

Do not ride your vehicle with worn or malfunctioning brakes! The brakes are the most important safety system of your vehicle, and using the bike with brakes that are anything less than perfect is very likely to lead to a collision or upset, with consequent risk of serious injury or death.

Check the brake pad wear, as shown on p. 42 (CHECKING WEAR OF THE BRAKE PADS).

**▲ WARNING**

Wet conditions seriously degrade the performance of your brakes. When the road is wet from rain, you should plan to use double the normal stopping distances since both the brakes themselves and the traction of the tires on the road are reduced by the presence of water.

Water on the brakes from washing your vehicle, or splashed up from wet roads, or crossing puddles or ditches, can wet the brakes sufficiently to greatly reduce their effectiveness. Failure to heed these warnings may lead to a serious accident with consequent risk of serious injury or even death.

NOTE This vehicle is equipped with front and rear disc brakes with separate hydraulic systems.

The following information may refer to just one braking system but should be observed with regard to both brakes.

NOTE For the version with rear drum brake , the following information refers to the front disc brake only.

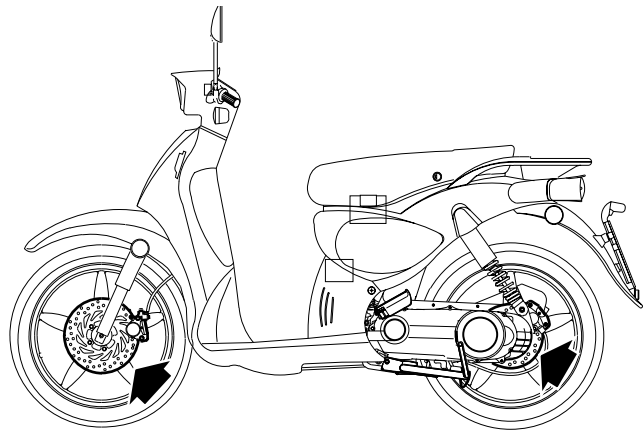
**▲ WARNING**

The brakes are extremely important for your safety. Do not use the vehicle if the brakes do not work perfectly. Always check the brake efficiency before riding.

▲ WARNING

Pay special attention to the brake disc and friction material, making sure that they are neither dirty nor oily, especially after maintenance operations or inspections.

Check the brake line, make sure that it is not twisted or kinked, nor leaking.

KEEP BRAKE FLUID AWAY FROM CHILDREN.

DISPOSE OF USED BRAKE FLUID PROPERLY. SEE THE GENERAL WARNINGS AT p. 2 (BRAKE FLUID).

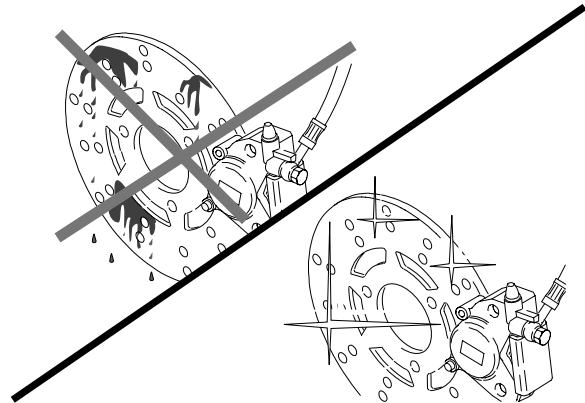

DISC BRAKES

Carefully read p. 2 (GENERAL SAFETY RULES) and p. 38 (BRAKES).

▲ WARNING

As mentioned above, the brakes are the most important safety system on your vehicle. For your safety, they must be in perfect repair, so they should be checked every time you ride your vehicle.

Oil or other fluid on a disc will contaminate the brake pads. Dirty pads must be discarded and replaced, a dirty or oily disc must be cleaned with a high quality degreaser.

Arrange to flush the systems and change all of the brake fluid once every two years.

NOTE This vehicle is provided with front and rear disc brakes with separate hydraulic systems.

NOTE For the version with rear drum brake , the following information refers to the front disc brake only.

As the pads wear out the brake fluid level in the reservoir decreases to automatically compensate for their wear.

The front brake fluid reservoir (1) is located on the right end of the handlebar near the front brake lever (under the upper handlebar cover).

The rear brake fluid reservoir (2) is located on the left end of the handlebar near the rear brake lever (under the upper handlebar cover).

Check the levels of the brake fluid in the reservoirs, see p. 40 (FRONT AND REAR BRAKE). Also, check the wear of the pads, see p. 42 (CHECKING WEAR OF THE BRAKE PADS), every 312 mi (500 km).

▲ WARNING

Never use your vehicle if any portion of either brake system is leaking.

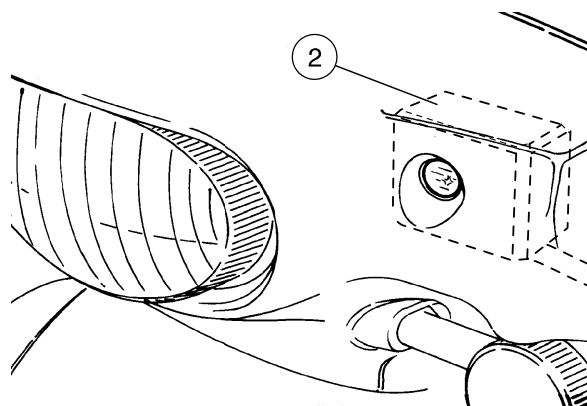
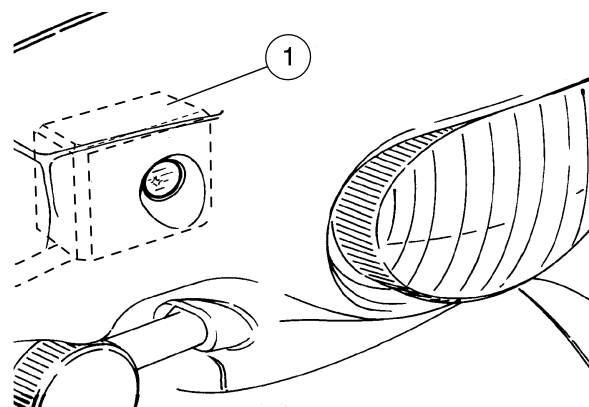
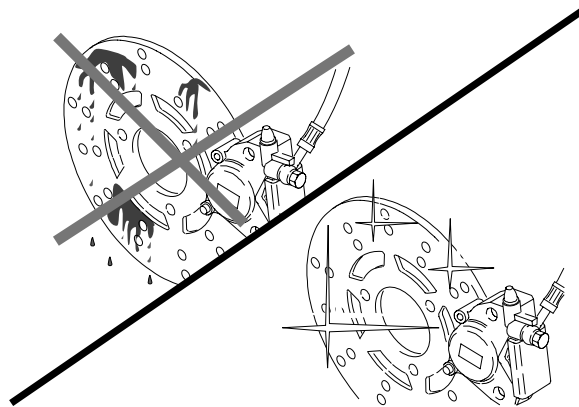

FRONT AND REAR BRAKE

Carefully read p. 39 (DISC BRAKES).

CHECKING THE SYSTEM

NOTE Carry out these checks only on a firm, flat surface such as a concrete garage floor.

- ◆ Place the vehicle on the center stand.

MIN = minimum level.

- ◆ Rotate the handlebar, so that the fluid contained in the brake reservoir is parallel to the “**MIN**” mark stamped on the glass gauge (3).
- ◆ Ensure that the fluid contained in the reservoir exceeds the “**MIN**” mark stamped on the glass gauge (3).

If the fluid does not reach the “**MIN**” mark:

▲ CAUTION

As the disc pads wear out, the level of the fluid decreases progressively to compensate for their wear.

- ◆ Check the brake pad wear, see p. 42 (CHECKING WEAR OF THE BRAKE PADS) and the disc wear.

If the pads and / or the disc do not need replacing:

- ◆ Check the brake system to determine the cause of the problem, checking:
 - the condition of the brake lines. Especially inspect for cracks or cuts;
 - the torque on the fittings;
 - the line fittings for leaks;
 - the brake caliper and the reservoir for leaks;
 - the bleed screw for leaks. If any seepage is observed, tighten to the appropriate tightening torque;
 - the reservoir caps for leaks and condition of the gasket.

After you have repaired the brake:

- ◆ Check and bleed the system, see above (FRONT AND REAR BRAKE) and see p. 43 (BLEEDING THE BRAKING SYSTEM).
- ◆ Top up the reservoir with appropriate brake fluid, see p. 41 (TOPPING UP).

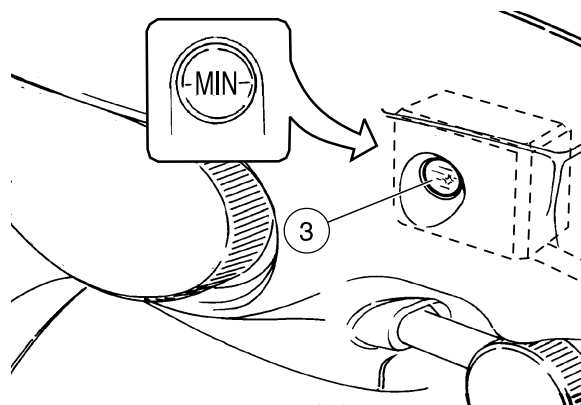
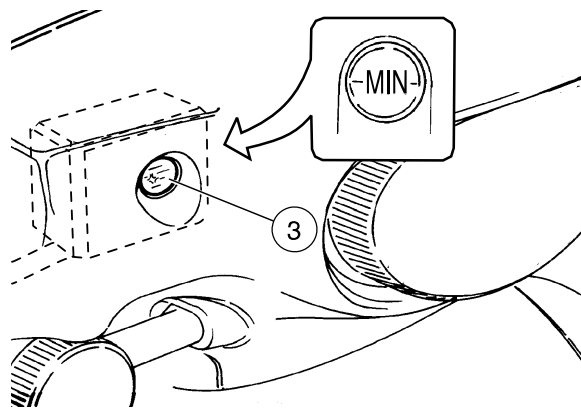

TOPPING UP

Carefully read p. 38 (BRAKES) and p. 39 (DISC BRAKES).

- ◆ Remove the front handlebar cover, see p. 22 (REMOVING THE FRONT HANDLEBAR COVER).

▲ CAUTION

To remove the two screws (1) which hold the reservoir cover (2) in place, the handlebar must be rotated so that the fluid contained in the brake reservoir is parallel to the "MIN" mark stamped on the glass gauge (3). If not, brake fluid will spill from the reservoir.

- ◆ Rotate the handlebar so that the fluid contained in the brake reservoir is parallel to the "MIN" mark stamped on the glass gauge (3).

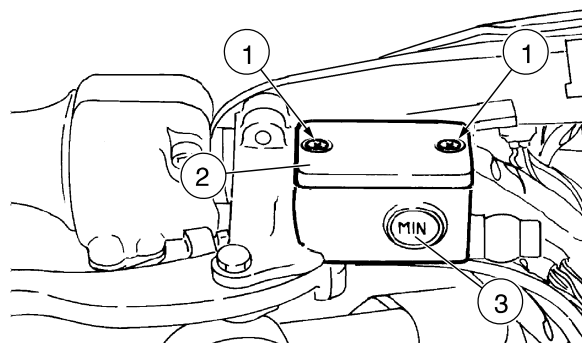

▲ CAUTION

Do not operate the front brake lever and do not rotate the handlebar with the screws (1) or the cover (2) removed. This will cause brake fluid to squirt out and spill.

- ◆ Unscrew the two screws (1).
- ◆ Remove the cover (2).
- ◆ Remove the guide cover (4).

▲ WARNING

Avoid any prolonged exposure of the brake fluid to the air.

The brake fluid is hygroscopic and when in contact with the air it absorbs its humidity.

Leave the brake fluid reservoir open ONLY for the time necessary for topping up.

NOTE In order not to spill the brake fluid while topping up, keep the fluid in the reservoir parallel to the reservoir rim, and do not shake the vehicle.

- ◆ Remove the gasket (5).

NOTE In order to reach the "MAX" level, top up until covering the glass (3) completely, but leave a space of 0.20 – 0.23 in (5 – 6 mm) from the brake fluid reservoir rim.

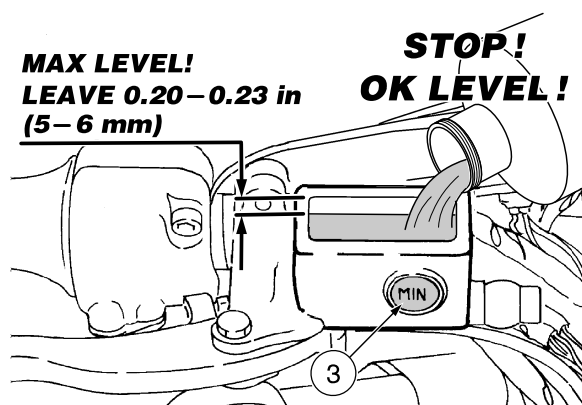
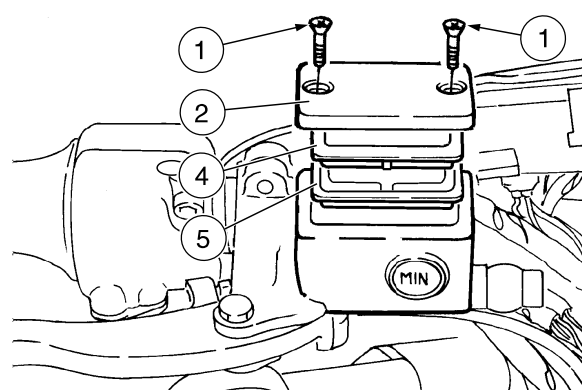

▲ CAUTION

When topping up, never exceed the "MAX" level. Top up to "MAX" only when new pads are installed. Do not fill the reservoir to "MAX" with worn pads; this will cause fluid to overflow the reservoir when the pads are renewed.

▲ WARNING

Use only DOT 5 or 4 fluid taken from a clean, sealed container. Never reuse used brake fluid.

- ◆ Top up the reservoir with brake fluid, until the fluid reaches the "MAX" level.
- ◆ Replace the gasket (5) in its seat correctly.
- ◆ Replace the guide cover (4) in its seat correctly.
- ◆ Replace the cover (2).
- ◆ Install and tighten the two screws (1).
- ◆ Replace the front handlebar cover, see p. 22 (REMOVING THE FRONT HANDLEBAR COVER).

▲ CAUTION

After servicing the brakes, always check them for function. If the stroke of the lever is excessive, or if you detect that the effectiveness of the brakes is reduced in any way. It may be necessary to bleed the system, see p. 43 (BLEEDING THE BRAKING SYSTEM), or there may be some other problem with the brake system.

Never ride your vehicle in traffic immediately after servicing the brakes.

Always apply the brake lever several times before riding your vehicle. Then, try your vehicle in a parking lot or other safe area with little traffic to ensure that the brakes are working properly. Failure to observe this warning can lead to a serious accident with subsequent serious injury or death.

BRAKE PADS

Carefully read p. 2 (GENERAL SAFETY RULES), and p. 39 (DISC BRAKES).

Check the brake pad wear after the first 312 mi (500 km) and then every 1,250 mi (2,000 km).

The amount of wear that the brake pads experience depends on how the vehicle is used, how aggressively it is driven, and the condition of the roads upon which it is operated.

Wear will be faster than normal when the vehicle is driven aggressively, or on dusty or wet roads.

CHECKING WEAR OF THE BRAKE PADS

- ◆ Place the vehicle on the center stand.
- ◆ **Only for the front brake caliper:** remove the brake caliper cover (1).

NOTE To check the rear brake pad wear, remove the rear brake caliper (2), see p. 45 (REMOVING THE REAR BRAKE CALIPER).

- ◆ Perform a visual check of the friction material thickness. Use a flash light.
- If the friction material on one pad of a pair, front or rear, is worn to **0.06 in (1.5 mm)** or less, replace both pads.

▲ WARNING

Excessive wear of the friction material would cause the contact of the pad metal support with the disc, with consequent metallic noise and production of sparks from the caliper; braking efficiency and safety will be seriously compromised. This could lead to a crash, with subsequent serious injury or death.

CHANGING THE BRAKE PADS

- ◆ Place the vehicle on the centre stand.

Only for the front brake caliper:

- ◆ Remove the brake caliper cover (1).
- ◆ Remove the snap ring (3).
- ◆ Withdraw the pin (4).
- ◆ Remove the spring (5).

Only for the front brake caliper:

NOTE The antisqueal plates (6) will come off together with the pads.

- ◆ Extract the pads (7) [(together with the antisqueal plates (6)), by withdrawing them one by one.
- ◆ Extract the pads (8), by withdrawing them one by one.

▲ CAUTION

Never apply the brake levers after removing the brake caliper. To do so will cause the caliper pistons to fall out of their seats in the caliper. This will cause brake fluid to spill from the caliper.

Always change both pads and make sure that they are correctly positioned inside the caliper.

- ◆ Insert two new pads (8).

Only for the front brake caliper:

- ◆ If the antisqueal plates (6) are worn, replace them.
- ◆ Insert two new pads (7) [(complete with antisqueal plates (6))].
- ◆ Insert the spring (5) correctly.
- ◆ Insert the pin (4).
- ◆ Install the snap ring (3).

Only for the front brake caliper:

- ◆ Install the brake caliper cover (1).
- ◆ Check the brake fluid level, see p. 40 (FRONT AND REAR BRAKE).

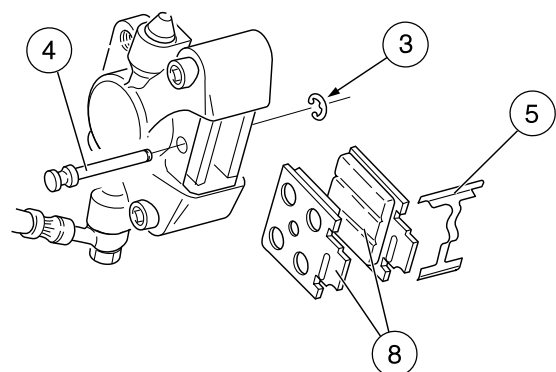
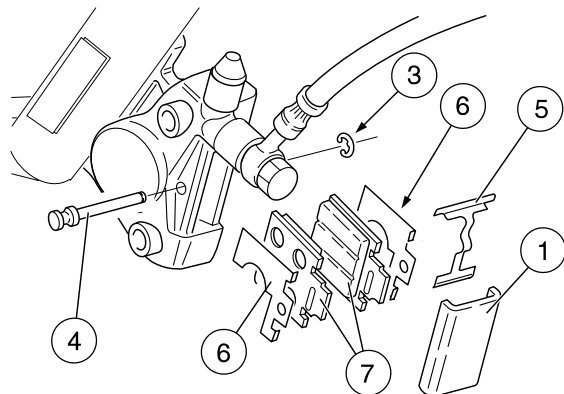
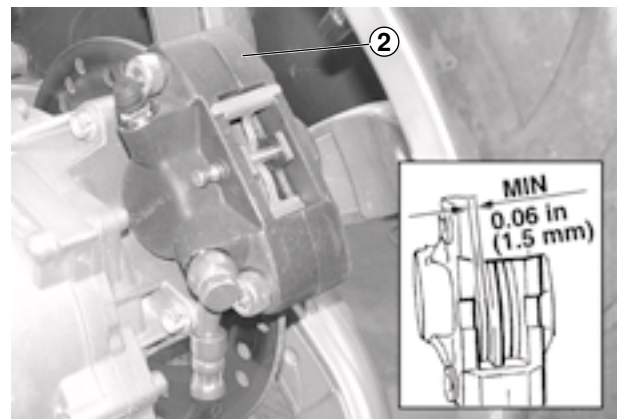
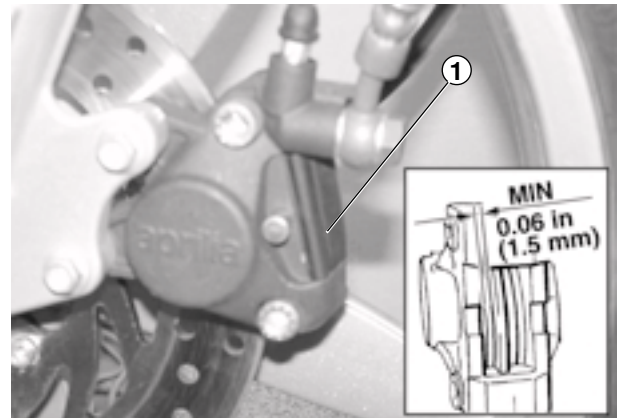

BLEEDING THE BRAKING SYSTEM

Carefully read p. 2 (GENERAL SAFETY RULES) and p. 39 (DISC BRAKES).

NOTE This vehicle is provided with front and rear disc brakes, with separate hydraulic system.

The following information may refer to a single braking system, but is applicable for both braking system.

NOTE For the version with rear drum brake (D), the following information refers to the front disc brake only.

When air is present in the hydraulic system it will absorb most of the force exerted by the brake master cylinder, and thus reduce the effectiveness of caliper action during braking. You can tell if there is air in the system by sponginess in the brake control, and reduced braking efficiency.

▲ WARNING

Since these conditions would be extremely dangerous for the vehicle and for the rider, it is absolutely necessary to bleed the hydraulic system after the reassembly of the brakes and the restoration of the normal conditions of use.

NOTE To bleed the hydraulic systems one by one.

- ◆ Carry out the operations described at paragraph "TOPPING UP", see p. 40 (section "DISC BRAKE", chapter "FRONT AND REAR BRAKE"), excluding the last five operations.
- ◆ Remove the protection cap (1) from the bleeder nipple (2).
- ◆ Connect a transparent tube (3) to the bleeder nipple (2).

▲ CAUTION

Do not contaminate the pads or the disc with brake fluid.

- ◆ Put the free end of the transparent tube into a clear container (4).
- ◆ Slowly pull the brake lever (5) through its full travel two or three times, then keep it in a fully pulled position.

▲ CAUTION

Loosen the bleeder nipple (2) and check the brake fluid level in the reservoir (6). Do not allow the reservoir to become completely empty. This will cause the introduction of more air into the brake system.

- ◆ Loosen the bleeder nipple (2) and check to see if bubbles still appear in the transparent tube (3).

▲ CAUTION

Before releasing the brake lever (5), close the bleeder nipple (2) in order to prevent air from entering the brake system that way.

- ◆ When brake fluid flows out clear, without bubbles, this indicates that you have successfully bled the air from the brake system. Close the bleeder nipple (2) snugly, and tighten it to its appropriate tightening torque.

Bleeder nipple (2) tightening torque:
2.90 - 8.68 ftlb (4 - 12 Nm).

NOTE Repeat the last three operations until eliminating the air bubbles completely.

- ◆ Replace the protection cap (1) on the bleeder nipple (2).
- ◆ Check the brake fluid level, see p. 40 (FRONT AND REAR BRAKE).

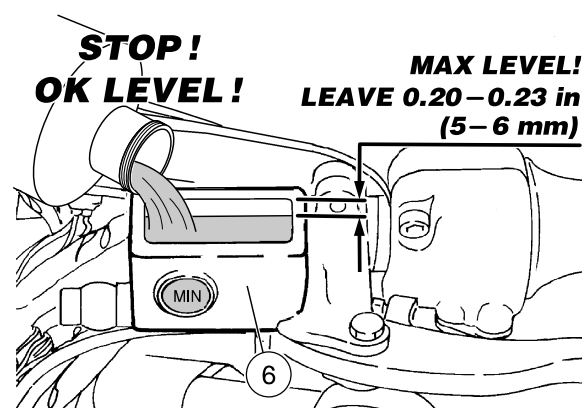
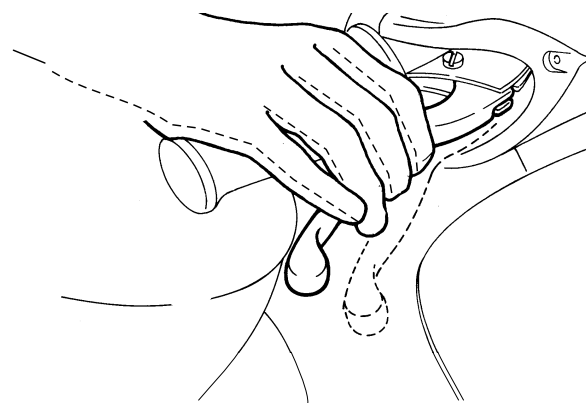
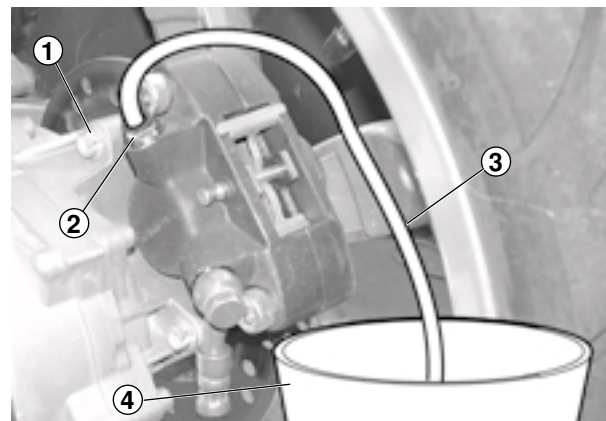

▲ WARNING

Pay special attention to the brake disc and friction material, making sure that they are neither dirty nor oily, especially after maintenance operations or inspections.

▲ WARNING

After reassembly, pull the brake lever repeatedly and check the proper functioning of the braking system.

BRAKE CALIPERS

Carefully read p. 2 (GENERAL SAFETY RULES), and p. 39 (DISC BRAKES).

REMOVING THE FRONT BRAKE CALIPER

Carefully read above (BRAKE CALIPERS).

▲ WARNING

A dirty disc soils the pads, with consequent reduction of the braking efficiency. Dirty pads must be replaced, while dirty discs must be cleaned with a high-quality degreaser.

▲ CAUTION

Upon disassembly, be careful not to damage the brake lines, disc and pads.

▲ CAUTION

Never apply the front brake lever after removing the brake caliper. To do so will cause the caliper pistons to fall out of their seats in the caliper. This will cause brake fluid to spill from the caliper.

- ◆ Remove the two screws (1) that fasten the caliper to the front support. Remove the caliper (2) by sliding out from the back in the direction shown by the arrow.

Brake caliper screw (1) tightening torque: 19.53 ftlb (27 Nm)

▲ CAUTION

After reassembly, pull the front brake lever repeatedly and check the correct functioning of the braking system.

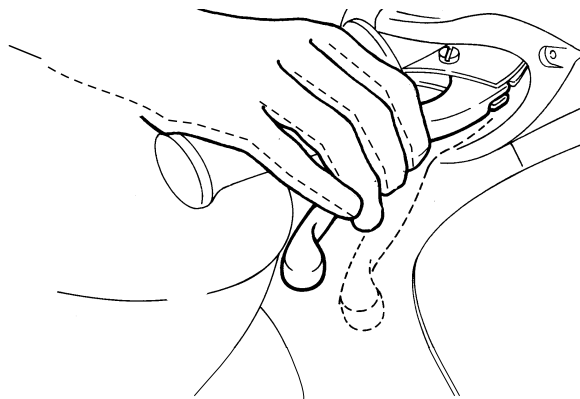
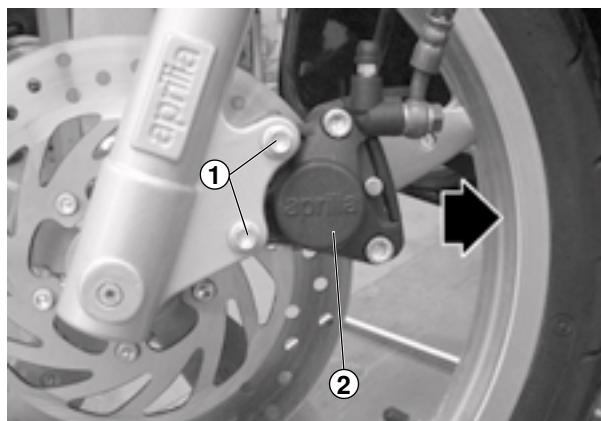
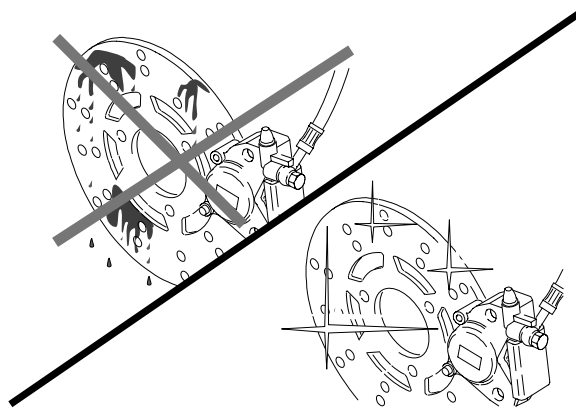

REMOVING THE REAR BRAKE CALIPER

Carefully read p. 44 (BRAKE CALIPERS).

▲ WARNING

A dirty disc soils the pads, with consequent reduction of the braking efficiency. Dirty pads must be replaced, while dirty discs must be cleaned with a high-quality degreaser.

DISASSEMBLY

▲ CAUTION

Upon disassembly, be careful not to damage the brake lines, disc and pads.

- ◆ Place the vehicle on the center stand.

▲ WARNING

Before carrying out the following operations, let the engine and the exhaust silencer cool down until they reach room temperature, in order to avoid burns.

- ◆ Unscrew and remove the two screws (1).

Brake caliper screw (1) tightening torque:
19.53 ftlb (27 Nm).

▲ CAUTION

Never apply the rear brake lever after removing the brake caliper. To do so will cause the caliper pistons to fall out of their seats in the caliper. This will cause brake fluid to spill from the caliper.

- ◆ Remove the brake caliper (2), by carefully withdrawing it from the brake disc.

REASSEMBLY

▲ WARNING

Keep your fingers clear, do not allow them to become crushed between the wheel, the caliper or the fork.

Do not attempt to align the holes in the caliper using your fingers. Use work-gloves to carrying out these operations. Failure to obey this warning can cause serious injury.

- ◆ Insert the brake caliper (2) on the disc and position it so that its fastening holes and the holes on the support are aligned.

▲ WARNING

When reassembling the brake caliper, replace the caliper screws (1) with two new screws of the same type.

- ◆ Tighten the two screws (1) to the appropriate torque.

Brake caliper screw (1) tightening torque:
19.53 ftlb (27 Nm).

▲ WARNING

After reassembly, pull the rear brake lever repeatedly and check the correct functioning of the braking system.

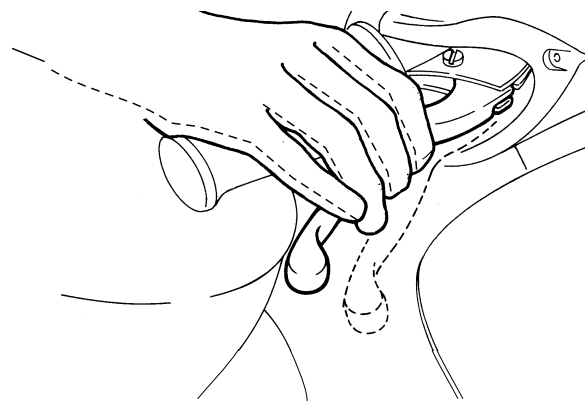
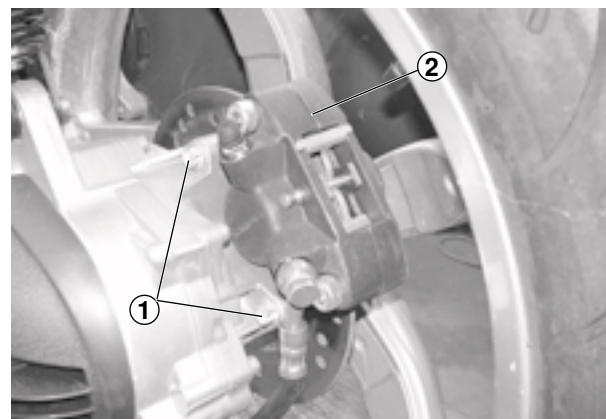
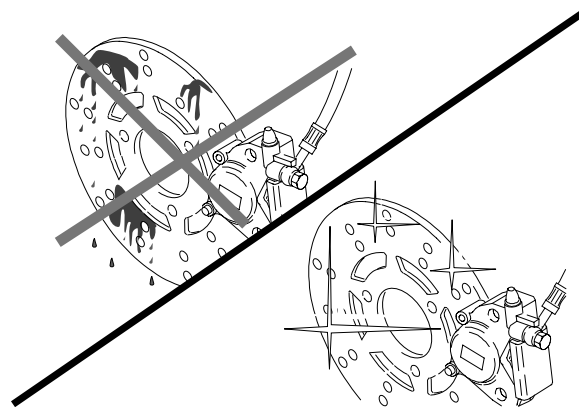

TRANSMISSION**CHECKING THE TRANSMISSION OIL LEVEL**

Carefully read p. 2 (GENERAL SAFETY RULES).

DISPOSE OF OIL PROPERLY

To control the transmission oil level, carry out the following operations every 1,750 mi (3,000 km) of use, or every 6 months:

- ◆ Run the engine for a few kilometers until it reaches its normal working temperature, and then stop the engine.
- ◆ Place the vehicle on the center stand.
- ◆ Remove the 8 screws (1) shown in the figure.
- ◆ Remove the casing (2).
- ◆ Place a measuring container with a capacity of no less than 120 cm³ under the bleeder cap (3).
- ◆ Unscrew the filling cap (4) and the oil bleeder cap (3).
- ◆ Let the oil flow out of the casing completely.
- ◆ Measure the amount of oil in the container and, if less than 110 cm³, top up to this level, see page 12 (LUBRICANT CHART).
- ◆ Tighten the bleeder cap (3).
- ◆ Use the oil from the measuring container to refill the tank.
- ◆ Tighten the filling cap (4).

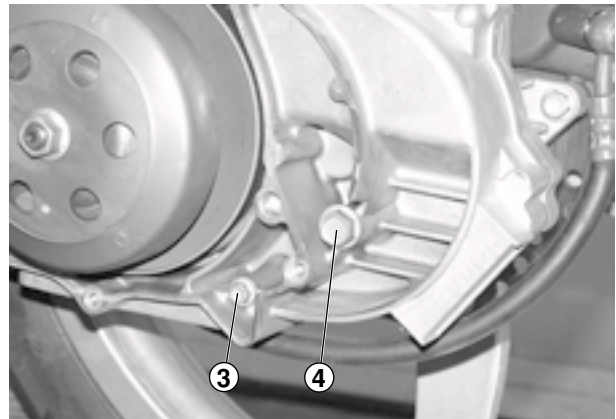
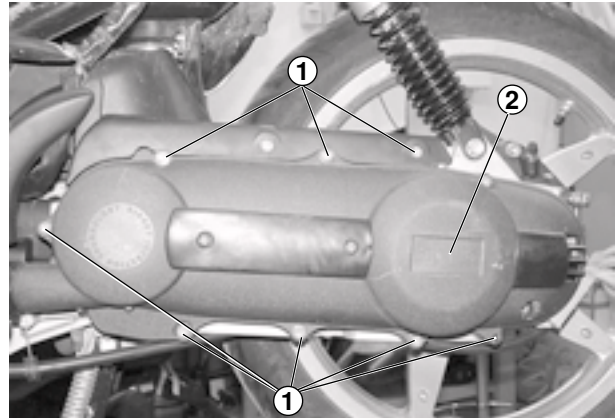
**▲ CAUTION**

Tighten the filling and bleeder caps well and make sure that no oil leaks out.

Check regularly for leaks around the casing cover gasket. Do not use the vehicle if there is insufficient lubricant or with contaminated or unsuitable lubricants, since these will speed up the wear of moving parts and can cause irreparable damage.

CHANGING THE TRANSMISSION OIL**DISPOSE OF OIL PROPERLY.**

We recommend that oil be consigned, in a sealed container, to the filling station where you usually purchase fuel, or to an oil collection point.

For an efficient, long-lasting vehicle, change the oil after the first 312 mi (500 km) and then every 7,500 mi (12,000 km) or every 2 years.

To change the oil:

- ◆ Run the engine for a few kilometers until it reaches its normal working temperature, and then stop the engine.
- ◆ Place the vehicle on the center stand.
- ◆ Place a measuring container with a capacity of no less than 120 cm³ under the bleeder cap (3).
- ◆ Unscrew the filling cap (4) and the oil bleeder cap (3).
- ◆ Let the oil flow out of the casing completely.
- ◆ Tighten the bleeder cap and pour in 110 cm³ of oil, see page 12 (LUBRICANT CHART).
- ◆ Tighten the filling cap (4).

▲ CAUTION

Tighten the filling and bleeder caps well and make sure that no oil leaks out.

Check regularly for leaks around the casing cover gasket. Do not use the vehicle if there is insufficient lubricant or with contaminated or unsuitable lubricants, since these will speed up the wear of moving parts and can cause irreparable damage.

WHEELS / TIRES

Carefully read p. 2 (GENERAL SAFETY RULES).

INSPECTING THE WHEELS

- ◆ Make sure that the wheel rims are neither cracked, nor deformed. Change them if necessary.
- ◆ Check the wheel eccentricity.
If it is deformed beyond the tolerance limits, check the rim and the bearings.
If necessary, replace the wheel.

Eccentricity limit:

Vertical: 0.07874 in (2 mm).

Lateral: 0.07874 in (2 mm).

- ◆ Check the wheel balancing.
- ◆ Place the wheel on a balancing stand, and rotate it several times, observing the position in which the wheel stops.
If the wheel is statically balanced, it will not always stop in the same place. If it always stops in the same place, the wheel is out of balance, and must be balanced.
Place balancing weights on the lightest side of the wheel until it no longer stops in any one position after being rotated several times.

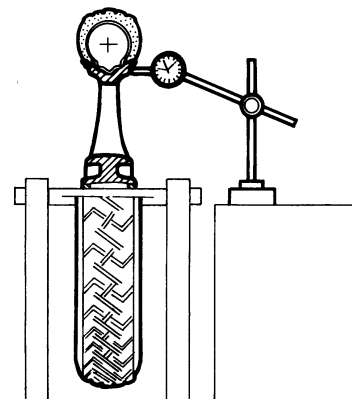
**TIRES**

This vehicle is equipped with inner tube tires, see p. 9 (TECHNICAL DATA).

▲ WARNING

Check the tire inflation at room temperature at least once a week, see p. 9 (TECHNICAL DATA).

Pressure measurement must always be carried out when the tires are cold, as when the tires are warmed up, pressure will increase, and if they are checked at this time erroneous readings will be seen.

If the tire is inflated to too high a pressure, an uncomfortably harsh ride will result, and riding comfort will be compromised. Also, road holding, especially during turns and in wet conditions, will likewise be compromised.

If the tire is underinflated (pressure is too low), the tire may slip on the rim with consequent loss of control. Again, road holding and handling characteristics will be degraded, and brake performance will be reduced.

When the tire is worn to a point where any tread is less than 0.12 in (3 mm) deep, the tire is worn out, and must be replaced. Also, if a tire suffers a puncture that is larger than 0.20 in (5 mm) in its longest dimension, the tire must not be repaired, but should be replaced.

After a tire is repaired, balance the wheels. Use only tires that are listed, see p. 9 (TECHNICAL DATA).

Insure that all tires are equipped with properly installed valve caps.

▲ WARNING

Change, repair, maintenance and balancing operations are very important and should be carried out by qualified technicians with appropriate tools.

If the tires are new, they may still be covered with a slippery film: drive carefully for the first miles.

Never attempt to treat a tire with any kind of rubber dressing. Particularly avoid contact to the tire with any petroleum fluid as this will cause rapid deterioration of the rubber.

If a tire becomes contaminated with oil or gasoline, you cannot clean it. The tire must be replaced.

- ◆ Check the tire frequently to ensure that there are not sidewall breaks, nor cuts in the tread or sidewall.
- ◆ Bulges and swelling, or an uneven sidewall, are signs of internal damage to the tire. A tire that is internally damaged must not be used, but must be replaced immediately.

**▲ WARNING**

Some of the original equipment tires for this vehicle are provided with wear indicators.

There are several kinds of wear indicators.

Contact your dealer to get the necessary information on the wear check procedures.

Visually check the tire wear and if they are worn, have them replaced.

If a tire should go flat while you are riding the vehicle, do not attempt to continue riding. Avoid abrupt braking and steering inputs, and avoid shutting the throttle quickly. Slowly decrease the throttle setting, moving to the side of the road, using the engine compression to slow you to a stop. Non-compliance with these instructions may cause accidents with consequent risk of injuries or even death.

Do not install tires with an inner tube on rims for tubeless tires, and viceversa.

Minimum tread depth is measured as shown above. The minimum tread depth (1) for both the front and the rear tires is 0.12 in (3 mm).

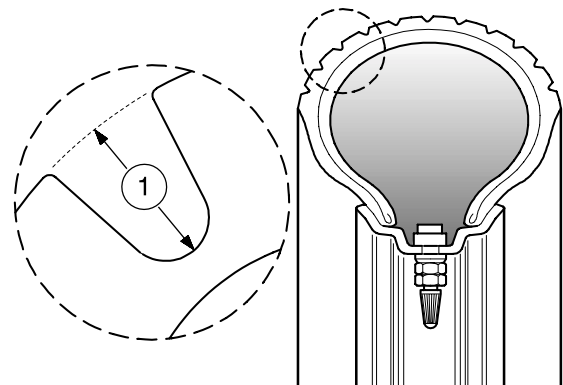

FRONT WHEEL**DISASSEMBLY**

Carefully read p. 2 (GENERAL SAFETY RULES).

▲ WARNING

While disassembling and reassembling the wheel, pay extra care not to damage the brake lines, discs or pads.

Before carrying out the following operations, let the engine and the exhaust silencer cool down until they reach room temperature, in order to avoid burns.

- ◆ Place the vehicle on the center stand.

NOTE Prepare a 78.74 in (200 mm) high support (1), the base of which must measure 78.74 x 78.74 in (200 x 200 mm).

- ◆ Place the support (1) under the vehicle and a soft cloth between them, so that the front wheel can move freely and the vehicle cannot fall down.
- ◆ Place a support (2) under the tire, in such a way as to keep the wheel in its position after loosening it.

▲ WARNING

Make sure that the vehicle is stable. If it falls, it may injure you or bystanders, as well as damaging property, and being damaged itself.

- ◆ Have a helper steady the handlebar in the straight ahead position.

Screw (3) tightening torque:

8.68 ftlb (12 Nm).

- ◆ Loosen the axle clamp screw (3), using the appropriate Allen wrench.

Axle (4) tightening torque:

36.17 ftlb (50 Nm).

- ◆ Unscrew the axle (4) completely with an appropriate Allen wrench.

NOTE Observe the arrangement of the speedometer drive (5) and of the washer (6), in order to be able to reassemble them correctly.

- ◆ Support the front wheel and remove the axle (4) manually.
- ◆ Remove the washer (6).

▲ CAUTION

Never touch the front brake lever after removing the front wheel. If you do, the caliper pistons may be pushed out of their seats, and brake fluid will be spilled.

- ◆ Pull the wheel out in the direction shown by the arrow (A).
- ◆ Remove the wheel completely by pulling it forward.
- ◆ Disconnect the speedometer drive (5).

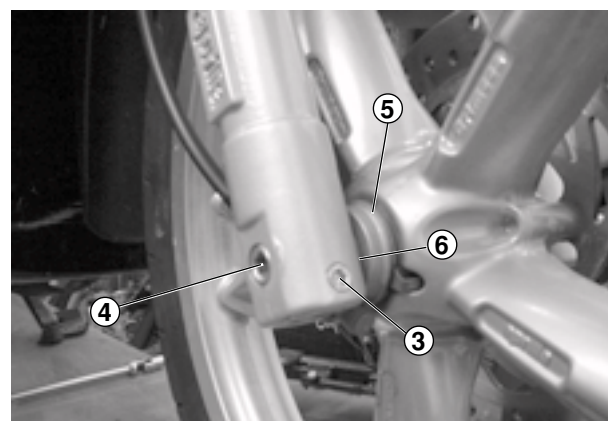
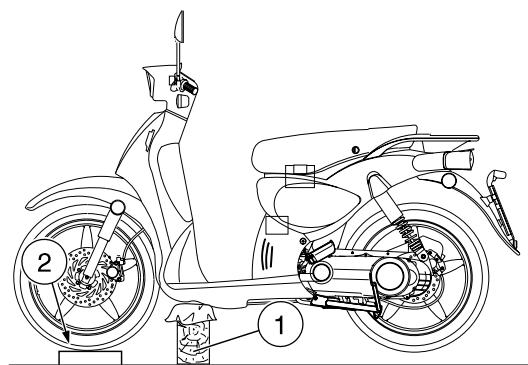

CHECKING

- ◆ Before reassembly, check the condition of the following parts, and if in any way damaged, replace them:
 - washer (6);
 - bearings (12);
 - speedometer drive (5);
 - spacer (13);
 - brake disc (14), [(minimum thickness 0.138 in (3.5 mm))];
 - front axle (4);

▲ WARNING

Riding with damaged rims is dangerous for the rider, the vehicle and other people.

Check the conditions of the wheel rim and the tire; if in any way damaged, replace them.

- wheel rim (15) see p. 47 (INSPECTING THE WHEELS);
- tire (16), see p. 47 (TIRES).
- ◆ Further, check the brake pad wear, see p. 42 (CHECKING WEAR OF THE BRAKE PADS).

REASSEMBLY

Carefully read p. 2 (GENERAL SAFETY RULES).

▲ WARNING

A dirty disc soils the pads, with consequent reduction of the braking efficiency. Dirty pads must be replaced, while dirty discs must be cleaned with a high-quality degreaser.

Before carrying out the following operations, let the engine and the exhaust silencer cool down until they reach room temperature, in order to avoid burns.

- ◆ Apply a thin film of lubricating grease, see p. 11 (LUBRICANT CHART) to the:
 - inside of the speedometer drive (5);
 - outer seats of the wheel hub;
 - front axle (4).
- ◆ Position the wheel on the support (2) between the fork legs.
- ◆ Position the tang (9) of the speedometer drive (5) in the appropriate seat on the wheel hub.

▲ CAUTION

While reassembling the wheel, be careful not to damage the brake line, the disc and the pads.

NOTE The slot (10) in the brake caliper (7) must be located in the lug (11) on the inside of the left fork leg.

- ◆ Insert the wheel between the fork legs, carefully introducing the disc into the brake caliper.

▲ WARNING

Danger of injury.

Keep your fingers clear. Do not attempt to line up the wheel and the axle clamps with your fingers. Use work-gloves to carrying out these operations.

- ◆ Move the wheel around until the axle hole and the axle clamps are aligned.
- ◆ Insert the washer (6) between the speedometer drive (5) and the fork right rod.
- ◆ Push in the axle (4) completely and tighten it to its appropriate tightening torque.

Axle (4) tightening torque: 36.17 ftlb (50 Nm).

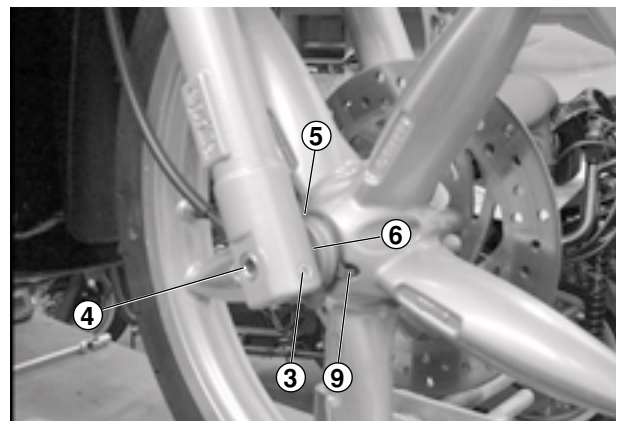
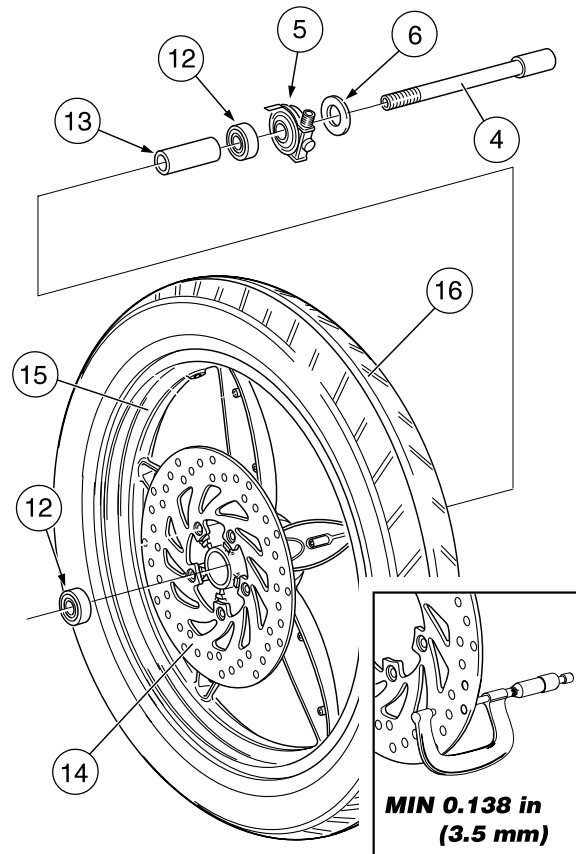

- ◆ Remove the support (2) from under the tire.
- ◆ Remove the support (1) from under the vehicle.
- ◆ Retract the center stand.
- ◆ Apply the front brake lever, and then push down on the handlebars, compressing the fork springs several times. This will align the fork tubes.
- ◆ Place the vehicle on the center stand.
- ◆ Tighten the axle clamp screw (3).

Screw (3) tightening torque:

8.68 ftlb (12 Nm).

- ◆ Make sure that the following components are not dirty:
 - tire;
 - wheel;
 - front brake disc;
 - front brake caliper.

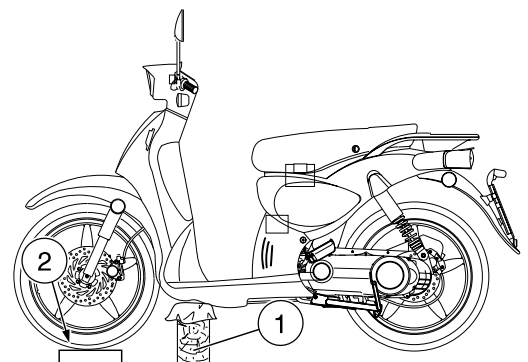

▲ WARNING

After servicing the brakes, always check them for function. If the stroke of the lever is excessive, or if you detect that the effectiveness of the brakes is reduced in any way, check the brake system, see p. 39 (DISC BRAKES).

It may be necessary to bleed the system, or there may be some other problem with the brake system.

Never ride your vehicle in traffic immediately after servicing the brakes. Always apply the brake lever several times before riding your vehicle. Then, try your vehicle in a parking lot or other safe area with little traffic to ensure that the brakes are working properly. Failure to observe this warning can lead to a serious accident with subsequent serious injury or death.

Check the tightening torques, centering and balancing of the wheel, see p. 47 (INSPECTING THE WHEELS). These are critical safety operations, and failure to observe this warning could lead to an upset with subsequent serious injury or death.

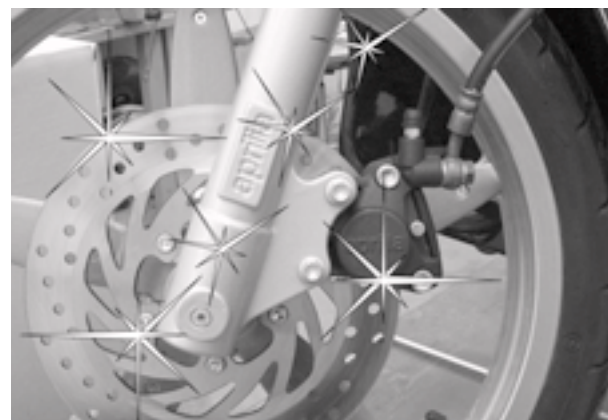

REAR WHEEL**DISASSEMBLY**

Carefully read p. 2 (GENERAL SAFETY RULES).

▲ WARNING

A dirty disc soils the pads, with consequent reduction of the braking efficiency. Dirty pads must be replaced, while dirty discs must be cleaned with a high-quality degreaser.

Riding with damaged rims is dangerous for the rider, the vehicle and other people.

Check the conditions of the wheel rim and the tire; if in any way damaged, replace them.

While disassembling and reassembling the wheel, pay extra care not to damage the brake lines, discs or pads.

◆ Remove the exhaust silencer, see p. 59 (EXHAUST SILENCER).

◆ Deflate the rear tire completely.

NOTE To unscrew the wheel nut (1), it is necessary to lock the rotation of the wheel.

◆ Pull the rear brake lever (2) completely, then put a small piece of cardboard (3) on the grip and keep the rear brake lever pulled by holding it against the grip by means of a tie wrap (4).

◆ Remove the cover (5).

◆ Unscrew and remove the wheel nut (1) and the washer.

NOTE Upon reassembly, use a new wheel nut. Do not reassemble your vehicle using the old wheel nut. This wheel nut is of a special type.

Wheel nut (1) tightening torque: 79.56 ftlb (110 Nm).

◆ Remove the tie wrap (4) and the cardboard (3).

◆ Release the rear brake lever (2).

◆  Withdraw the wheel.

◆ Remove the rear brake caliper, see p. 45 (REMOVING THE REAR BRAKE CALIPER).

◆ Withdraw the wheel.

Upon reassembly:

◆ Make sure that the following components are not dirty:

- tire;
- wheel;
- rear brake disc;
- rear brake caliper.

▲ WARNING

After servicing the brakes, always check them for function. If the stroke of the lever is excessive, or if you detect that the effectiveness of the brakes is reduced in any way, check the brake system, see p. 39 (DISC BRAKES) it may be necessary to bleed the system, or there may be some other problem with the brake system.

Never ride your vehicle in traffic immediately after servicing the brakes.

Always apply the brake pedal or lever several times before riding your vehicle. Then, try your vehicle in a parking lot or other safe area with little traffic to ensure that the brakes are working properly. Failure to observe this warning can lead to a serious accident with subsequent serious injury or death.

Check the tightening torques, centering and balancing of the wheel, see p. 47 (INSPECTING THE WHEELS). These are critical safety operations, and failure to observe this warning could lead to an upset with subsequent serious injury or death.

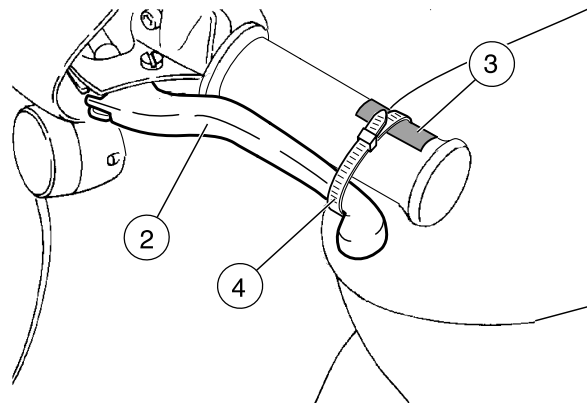
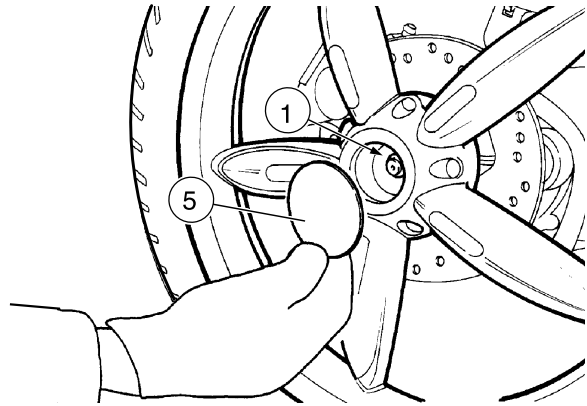

CHECKING THE ENGINE FULCRUM AXIS

Carefully read p. 2 (GENERAL SAFETY RULES).

Periodically check the engine fulcrum shaft and bushings for slack.

To carry out this operation, proceed as follows:

- ◆ Place the vehicle on the center stand.

▲ WARNING

Before carrying out the following operations, let the engine and the exhaust silencer cool down until they reach room temperature, in order to avoid burns.

- ◆ Grasp the wheel firmly and try to move it perpendicularly to the normal direction of travel (see figure).
- ◆ If any play is detected, check all of the fasteners attaching the mounting unit, see p. 62 (ENGINE MOUNTING BUSHINGS).
- ◆ If play can still be detected, contact your Local aprilia Dealer for repair instructions.

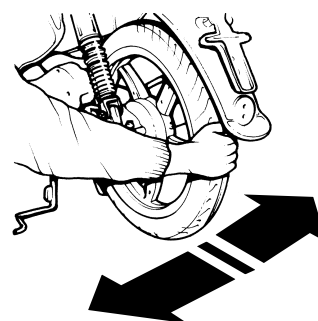
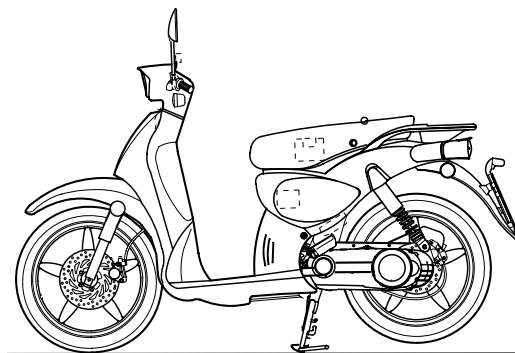

IGNITION SWITCH / STEERING LOCK

REMOVAL

- ◆ Remove the front cover, see p. 21 (REMOVING THE FRONT COVER).
- ◆ Disconnect the two electric connectors (1) and (2).
- ◆ Unscrew and remove the two screws (3) (special type).

NOTE Upon reassembly change the screw (3) (special type) with a new one.

- ◆ Remove the complete switch.

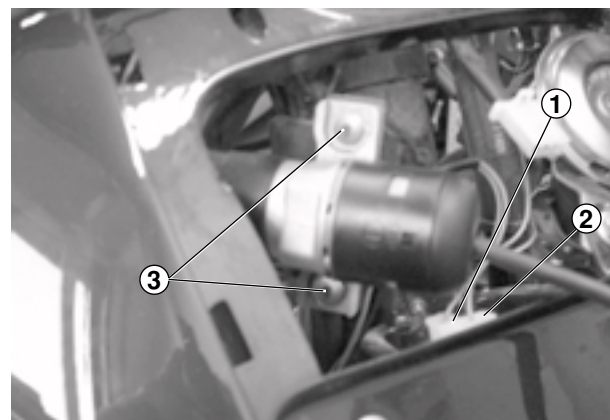

AIR CLEANER

Carefully read p. 2 (GENERAL SAFETY RULES).

▲ WARNING

The state of the air filter should be checked monthly or every 2,500 mi (4,000 km), depending on the conditions in which the vehicle is used.

If it is used on dusty or wet roads, cleaning and replacement operations must be carried out more frequently.

REMOVAL THE AIR FILTER

- ◆ Place the vehicle on the center stand.
- ◆ Remove the inspection cover, see page 19 (REMOVING THE INSPECTION COVER).
- ◆ Remove the pipe (2) supplying fuel to the injector from its housing on the air filter cover (1).
- ◆ Unfasten and remove the seven screws (3).

NOTE If the filter is dirty, remove the filter element (4) and replace it.

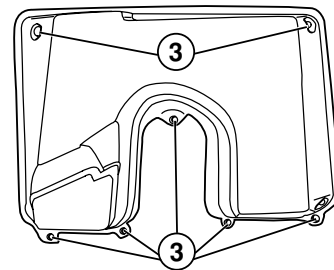
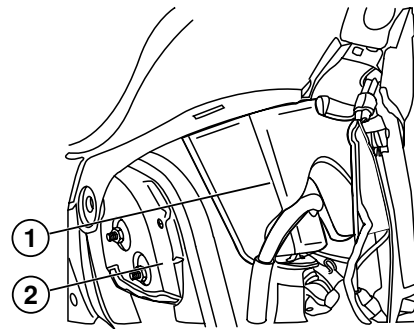

REMOVING THE COMPLETE AIR CLEANER CASING

Carefully read p. 2 (GENERAL SAFETY RULES).

- ◆ Remove the spark plug inspection cover as described on page 19 (REMOVING THE INSPECTION COVER).
- ◆ Free the fuel pipe (1) from the filter case (2).

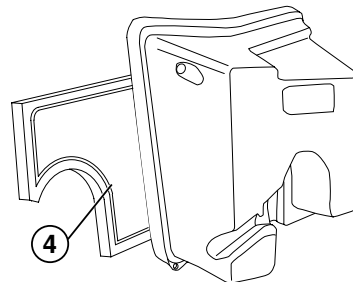

- ◆ Remove the electric connection on the fuel injector (3).

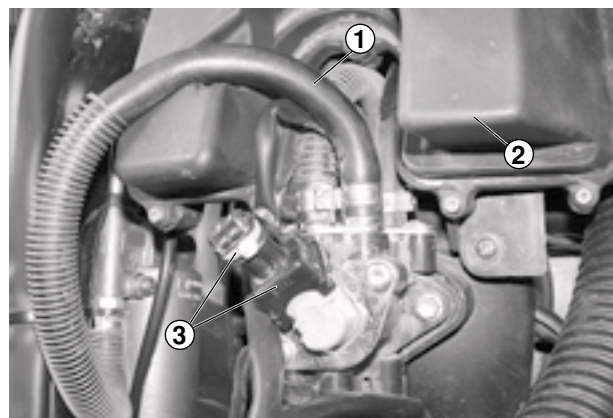

- ◆ Remove the two screws (4) sideways.

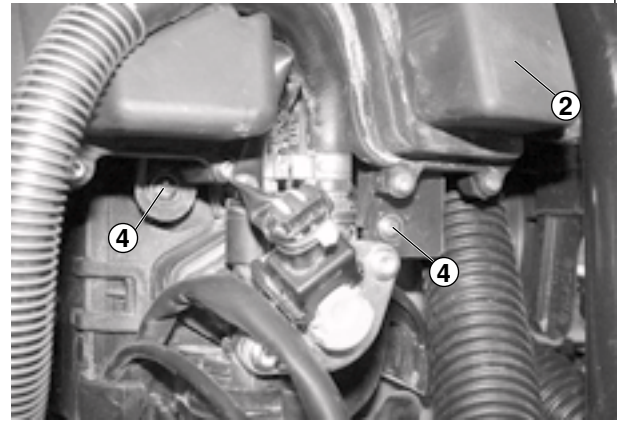

- ◆ Remove the two screws (5) that fix the guard (6) to the engine.
- ◆ Unscrew the screw (7) and lift the rear shock absorber.

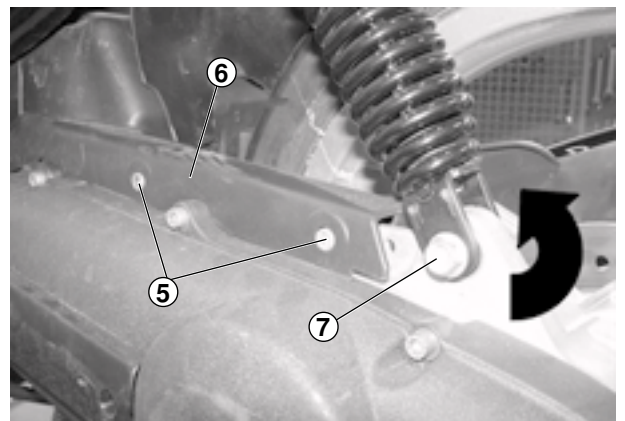

- ◆ Unscrew the two screws (8) and (9) from the flywheel side.
- ◆ Remove the guard (6).

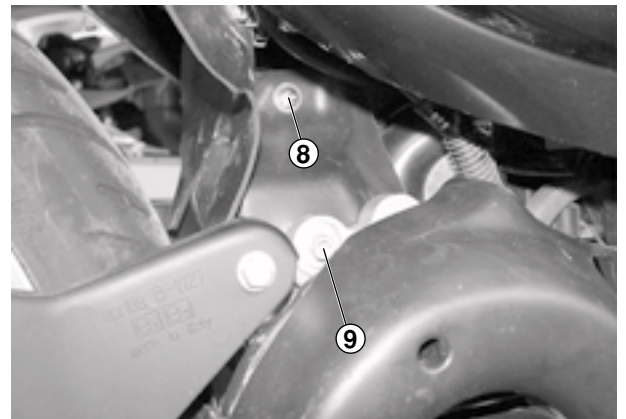

- ◆ Remove the clamp (10).
- ◆ Remove the whole air filter case (2) from the front.

NOTE On reassembly, fit a new clamp.

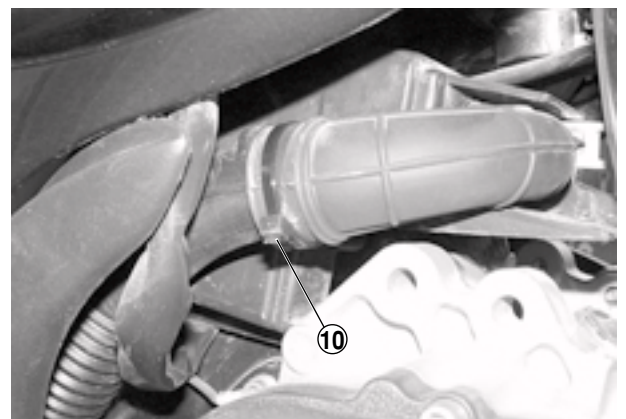

FORK HEAD

CHECKING THE BEARING PLAY

Carefully read p. 2 (GENERAL SAFETY RULES).

To check the steering it is necessary to:

- ◆ Place the vehicle on the center stand.

NOTE Prepare a 7.87 in (200 mm) high support, the base of which must measure 7.87 x 7.87 in (200 x 200 mm).

- ◆ Place the support (1) under the vehicle and a soft cloth between them, so that the front wheel can move freely and the vehicle cannot fall down.

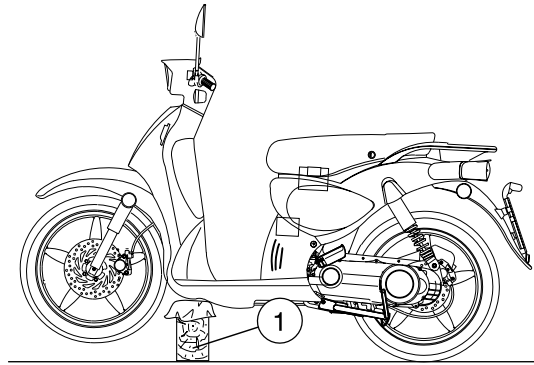

▲ WARNING

Make sure that the vehicle is stable. If it falls, it may injure you or bystanders, as well as damaging property, and being damaged itself.

- ◆ Grasp the lower fork legs and pull the fork fore and aft, with the steering in a straight ahead position.

NOTE Be careful when performing this measurement not to confuse play in the center stand with play in the fork head. You should repeat this test several times before deciding that the fork head needs to be adjusted.

- ◆ There should be no fore and aft slack. If you detect any slack, the fork head bearings must be adjusted, see below (ADJUSTING THE BEARING PLAY).

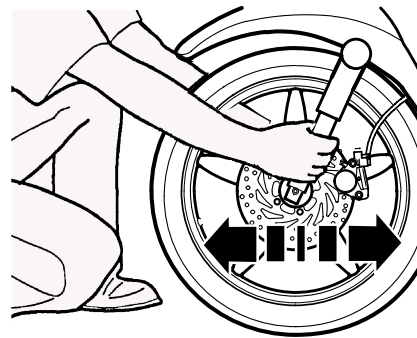

ADJUSTING THE BEARING PLAY

- ◆ Remove the front inner shield, see p. 21 (REMOVING THE FRONT INNER SHIELD).

▲ CAUTION

Proceed with care.

Handle the plastic and painted components with care and avoid scraping or damaging them.

- ◆ Remove the snap-in plug (2).
- ◆ Working through the hole (3), prevent the screw (4) from rotating with an appropriate Allen wrench.

Nut (5) tightening torque: 36.17 ftlb (50 Nm).

- ◆ Remove the nut (5).

NOTE There is a groove in the steering column which engages screw (4). This centers the handlebar, and prevents it from accidentally coming off.

You must remove screw (4) as far as possible before lifting the handlebar off.

- ◆ Pull screw (4) as far out of the tabs through which it passes as possible (the rear handlebar cover makes it impossible to remove it completely).
- ◆ Raise the handlebars a few centimeters.
- ◆ Remove the rubber gasket (6).
- ◆ Loosen the lock nut (7) using an appropriate open end wrench.

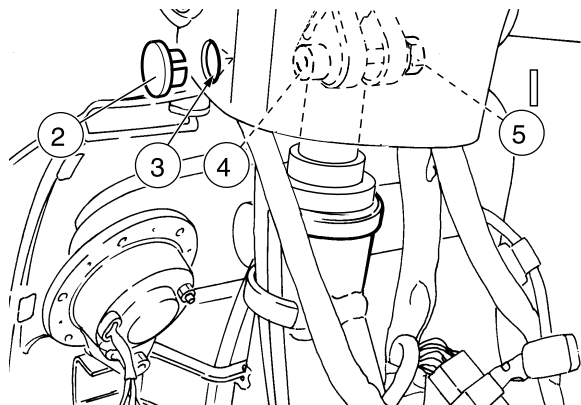

▲ CAUTION

Do not over tighten the adjusting nut (8). Over tightening the nut could damage the steering bearings.

- ◆ Tighten the adjusting nut (8) until all the bearing play is removed.
- ◆ Check the play as described above. Make sure that the front fork can move throughout its entire range, stop to stop, in a free and smooth rotation.
- ◆ Hold the adjusting nut (8) in position using an appropriate open end wrench and tighten the lock nut (7). Check the bearing play again after you have tightened the lock nut to insure that the adjustment is maintained.

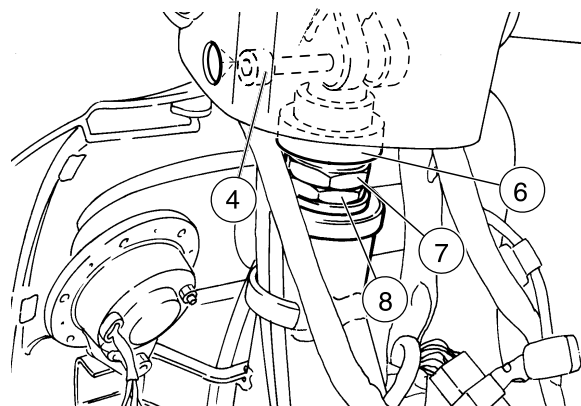

REMOVING THE FORK HEAD BEARINGS

Carefully read p. 2 (GENERAL SAFETY RULES).

▲ WARNING

Put a proper support under the vehicle, in order to prevent it from falling down.

- ◆ Place the vehicle on the center stand, on a lifting platform, with the front wheel protruding from the platform edge.
- ◆ Lift the platform at 19.69 - 23.62 in (50 – 60 cm) from the ground, in order to be able to withdraw the fork together with the wheel without problems.
- ◆ Free the odometer cable (1) from the slit (2) in the mudguard.
- ◆ Unscrew the ring nut (3).
- ◆ Disconnect the speedometer/odometer cable from the wheel transmission (4).

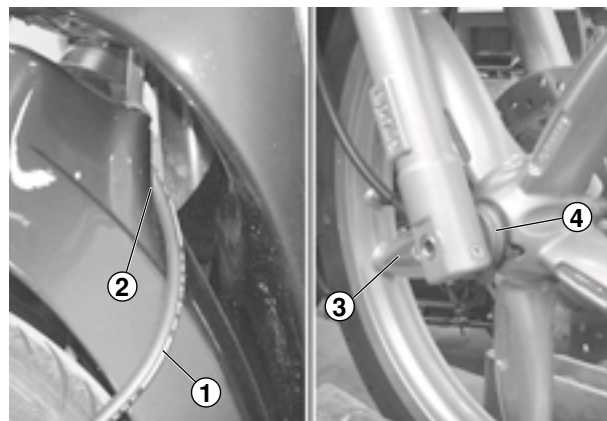
**▲ CAUTION**

Do not force the cables, tubes, lines, connectors or wires.

- ◆ Remove the handlebars completely.
- ◆ Support the handlebars so that they do not strain the wires and cables.
- ◆ Withdraw and remove the rubber gasket (5).
- ◆ Unscrew and remove the lock nut (6).

▲ WARNING

- ◆ Unscrew and remove the adjusting nut (7).

▲ CAUTION

When removing the fork, be careful to capture all of the fork head bearing balls. They are not caged, and will fall free as the fork is removed.

- ◆ Remove the fork from the steering tube.
- ◆ Remove the inner race (8) and balls (9) from the upper bearing (10).
- ◆ Remove the inner race (11) and the balls (12) from the lower bearing (13).
- ◆ Carefully wash all of the bearing components, including the outer races (14) and (15).
- ◆ Inspect all components for wear, if necessary replace them.
- ◆ Liberally grease all bearing components, holding the balls in place in the outer race with the grease before attempting to assemble the fork by reversing the above procedure.

▲ CAUTION

Upon reassembly, pay attention to the correct number of balls to be inserted:

- upper bearing (11) # 21 balls (10);
- lower bearing (14) # 25 balls (13).

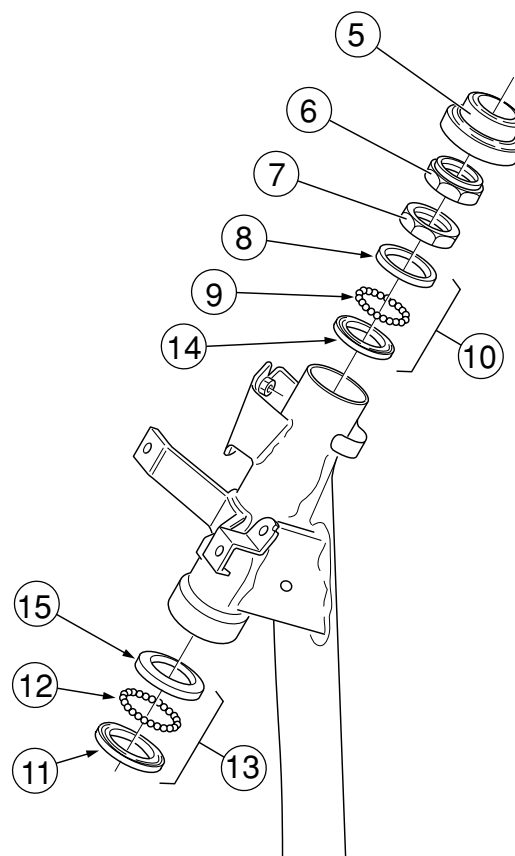
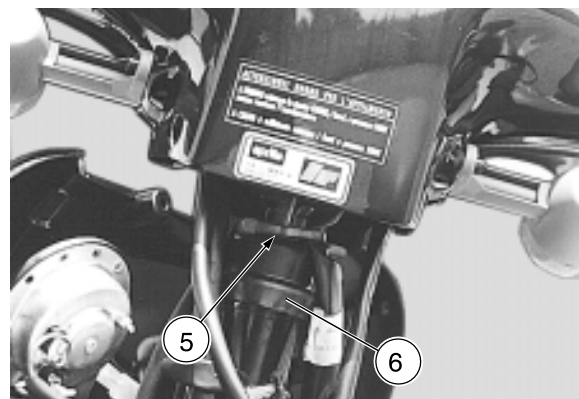

FRONT FORK

REMOVING THE COMPLETE FORK

To remove the complete fork, along with front wheel and front mudguard mounted, follow the instructions of p. 57 (REMOVING THE FORK HEAD BEARINGS).

In case of removing for replacement of the complete fork, keep to the instructions of p. 57 (REMOVING THE FORK HEAD BEARINGS) REPLACING THE TWO OPERATIONS:

- ◆ Unscrew the metal ring (3).

WITH THE FOLLOWING OPERATION:

- ◆ Remove the front wheel, see p. 49 (FRONT WHEEL).

After removing the fork:

- ◆ Remove the front mudguard, see p. 23 (REMOVING THE FRONT MUDGUARD).

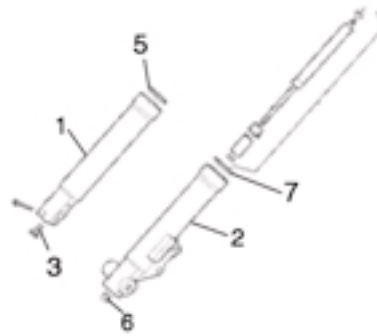

DISASSEMBLING THE LOWER FORK LEGS

Carefully read p. 2 (GENERAL SAFETY RULES).

NOTE The lower fork legs (1) and (2) can be removed from the forks, even with the fork installed in the vehicle.

- ◆ Remove the front wheel, see p. 49 (FRONT WHEEL)

To disassemble the right lower fork leg (1):

- ◆ Remove the screw (3).

Screw (3) tightening torque: 17.36 ftlb (24 Nm).

- ◆ Withdraw the right lower fork leg (1).
- ◆ Check the wear of the sealing ring (5), replace it if necessary.

To disassemble the left lower fork leg (2):

- ◆ Remove the nut (6).

Nut (6) tightening torque: 17.36 ftlb (24 Nm).

- ◆ Withdraw the left lower fork leg (2).
- ◆ Check the wear of the sealing ring (7) and replace it if necessary.

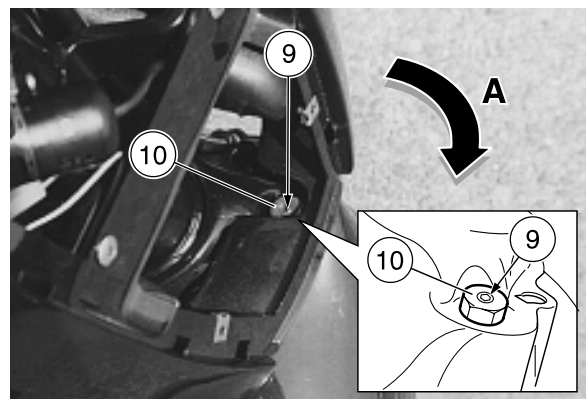

REMOVING THE COMPLETE DAMPER

Only the left fork tube contains a damper (8).

The damper may be removed, even with the fork installed on the vehicle.

- ◆ Remove the left lower fork leg (2), see above (DISASSEMBLING THE LOWER FORK LEGS).
- ◆ Remove the front cover, see p. 21 (REMOVING THE FRONT COVER).
- ◆ Rotate the handlebar completely clockwise (right-wards).
- ◆ Prevent the screw (9) from rotating with an appropriate Allen wrench.
- ◆ Remove the nut (10).

NOTE Upon reassembly, position the nut (10) correctly.

- ◆ Withdraw the complete damper (8).

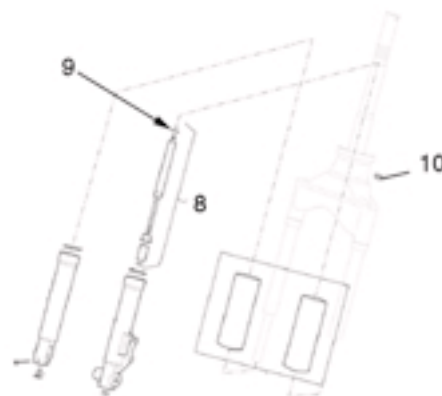

REAR SUSPENSION**REMOVAL**

Carefully read p. 2 (GENERAL SAFETY RULES).

- ◆ Place the vehicle on the center stand.

▲ CAUTION

Put a proper spacer (X) under the rear wheel to prevent it from falling and pushing the air cleaner casing into the frame.

▲ WARNING

Support the rear part of the frame to prevent it from dropping during the removal of the shock absorber.

- ◆ Remove the upper screw (2) and washer.
- Upper screw tightening torque: 36.17 ftlb (50 Nm).**
- ◆ Remove the lower screw (1) and washer.
- Lower screw tightening torque: 18.08 ftlb (25 Nm).**
- ◆ Remove the shock absorber (3).

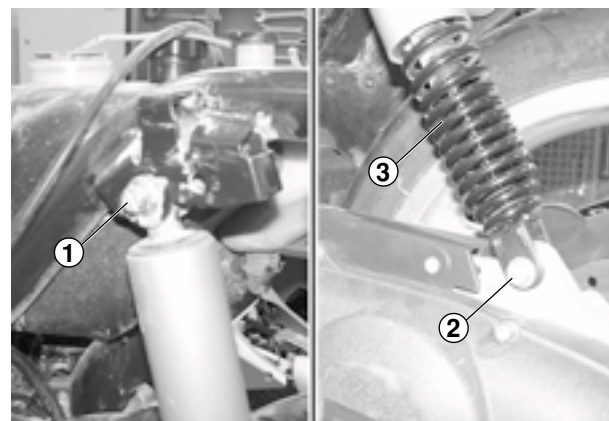
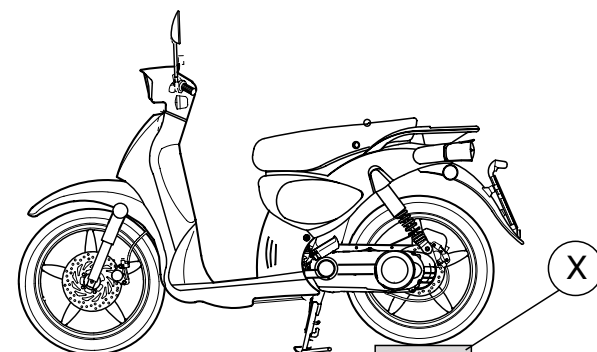
**EXHAUST SILENCER****DISASSEMBLY**

Carefully read p. 2 (GENERAL SAFETY RULES).

- ◆ Place the vehicle on the center stand.

▲ WARNING

Before carrying out the following operations, let the engine and the exhaust silencer cool down until they reach room temperature, in order to avoid burns.

▲ CAUTION

If the additional flange (4) is provided, do not unscrew the screws (5) and (6), but follow the procedure described here.

- ◆ Unscrew and remove the screws (7) and (8).
- Screw (7) and (8) tightening torque: 8.68 ftlb (12 Nm).**
- ◆ Unscrew and remove the two screws (5) and (6) that fasten the exhaust silencer to the engine.
- Screw (5) and (6) tightening torque: 18.08 ftlb (25 Nm).**
- ◆ Remove the exhaust silencer.

NOTE Upon reassembly, replace the gasket positioned between the exhaust manifold and the silencer with a new one.

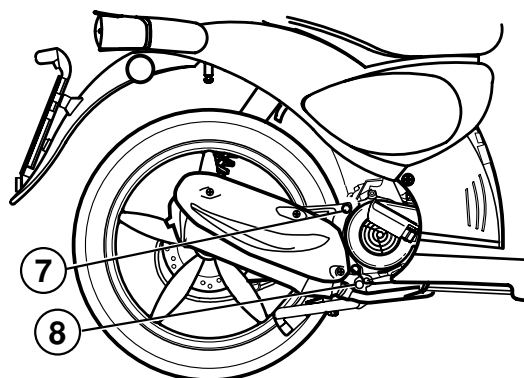
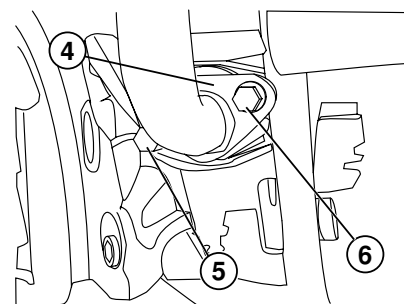

ENGINE

REMOVING THE ENGINE FROM THE FRAME

Carefully read p. 2 (GENERAL SAFETY RULES).

- ◆ Place the vehicle on the center stand.
- ◆ Remove the rear part of the fairing, as described on page 19 (REMOVING THE REAR PART OF THE FAIRING).
- ◆ Slide out the spark plug.
- ◆ Disconnect the electric connectors of the starter motor (1) and generator (2) and (3).
- ◆ Remove the air filter case (see page 54) (REMOVING THE COMPLETE AIR CLEANER CASING).

▲ WARNING

Wash your hands carefully after handling the oil. Dispose of oil properly.

- ◆ Bleed the 2 stroke oil tank completely, see page 29 (BLEEDING THE 2 STROKE OIL TANK).
- ◆ Collect the oil in a container and seal it.
- ◆ Disconnect the oil pipes.

▲ CAUTION

On reassembly, after refilling the tank, bleed the 2 stroke oil tank, see page 29 (BLEEDING THE 2 STROKE OIL TANK).

- ◆ Remove the screw (4) that supports the fuel pipe (5); remove the plate (6) and slide out the whole assembly.
- ◆ Remove the connectors (7) of the throttle positioning sensor (8), temperature sensor (9) and air injector.

- ◆ Remove the screw (10) that fastens the ground cable to the engine.

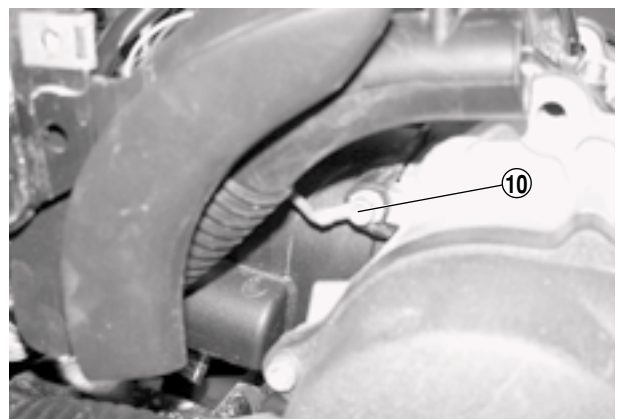
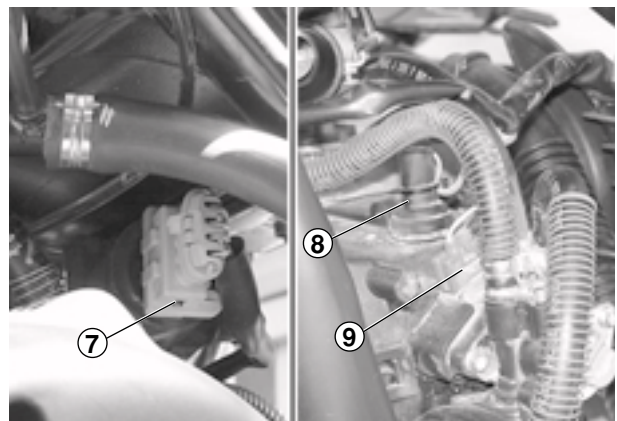
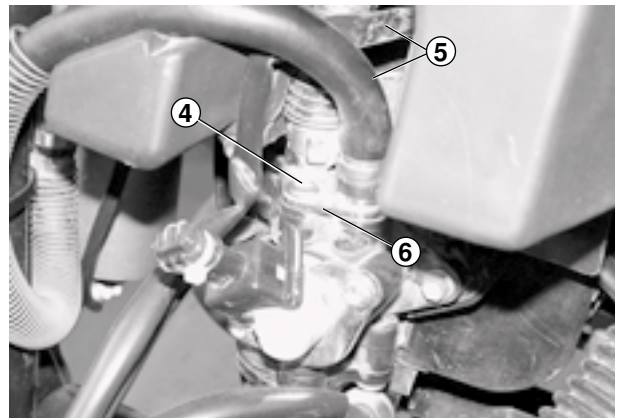
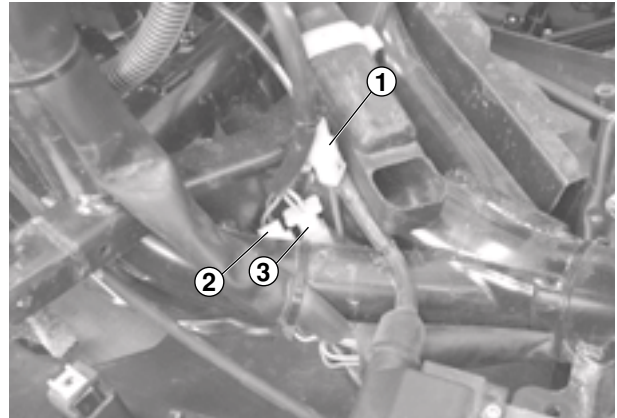

- ◆ Remove the rear brake caliper, see page 45 (REMOVING THE REAR BRAKE CALIPER).
- ◆ Fix the brake caliper to the vehicle frame.
- ◆ Unscrew and remove the screw (11) and free the brake pipe from the cable gland (12).
- ◆ Unscrew and remove the bottom screw of the shock absorber (13), complete with washer.

Screw (13) tightening torque: 18.08 ftlb (25 Nm)

- ◆ Rotate the shock absorber and fix it to the frame.

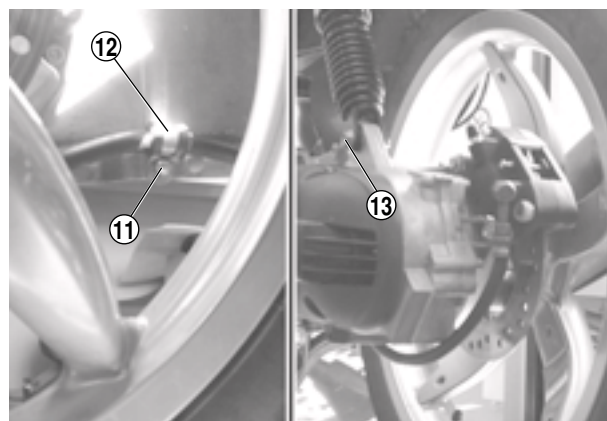

- ◆ Unscrew and remove the engine fulcrum-connecting rod nut (14) and relevant washer.

Engine fulcrum-connecting rod pin nut tightening torque: 36.17 ftlb (50 Nm).

NOTE Prepare a support to insert between the engine fulcrum-connecting rod pin couplings in order to sustain the vehicle without engine, back wheel, exhaust silencer and center stand.

▲ WARNING

The following operations require the assistance of a second operator, because of the weight and size of the components and vehicle.

Agree beforehand on how to divide up the tasks (the tasks are marked as follows: those marked “A” are to be done by the first operator and those marked “B” by the second operator), the procedure to follow and any warning signals.

PROCEED WITH GREAT CARE.

▲ WARNING

The size and weight of the vehicle may cause it to tilt dangerously during lifting, with the possibility of the whole vehicle tipping over.

PROCEED WITH CARE AND MAKE SURE THAT YOU ARE ABLE TO BEAR THE WEIGHT OF THE VEHICLE.

- ◆ “A” Grip the frame and lift the rear section of the vehicle.
- ◆ “B” Slide the engine fulcrum-connecting rod pin (15) and relevant washer out completely.

▲ WARNING

As it moves forward, if not checked, the front wheel may move to one side, compromising both the stability of the vehicle and operator safety.

- ◆ “A” and “B” Hold the handlebar and move the vehicle far enough forward to be away from the engine.
- ◆ “A” Support the vehicle.
- ◆ “B” Place a previously prepared support between the engine fulcrum-connecting rod pin attachments.
- ◆ “A” Lower the vehicle and make sure that it is resting in a safe position.

▲ WARNING

Carry out all maneuvers with caution. Be careful of fingers and limbs.

Take care during lifting and movement operations, since the stand, when it returns to its idle position, risks crushing or injuring limbs or fingers.

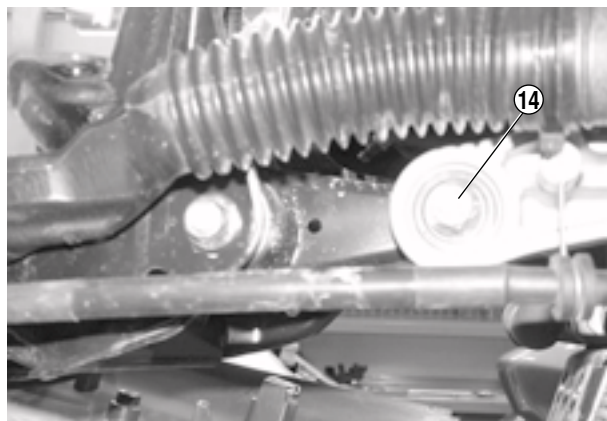
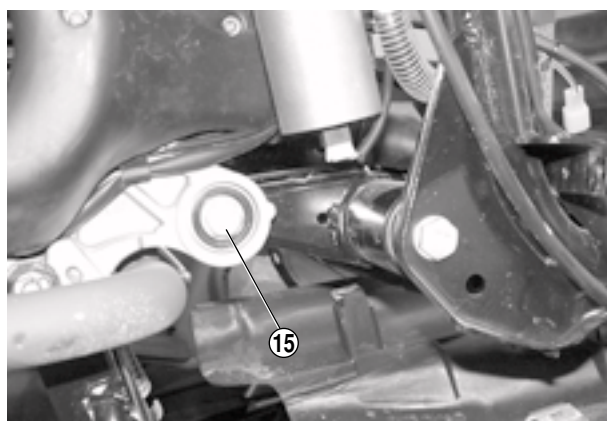

▲ CAUTION

Block the intake manifold of the engine to prevent impurities or foreign objects from entering it.

- ◆ “A” and “B” Lift the engine, complete with wheel, exhaust silencer and center stand, and place it on a workbench.

ENGINE MOUNTING BUSHINGS

REMOVAL

Carefully read p. 2 (GENERAL SAFETY RULES).

Worn out or damaged bonded rubber engine mounting bushings can cause annoying vibration and unsafe vehicle handling.

To check the condition of the bushings, it is necessary to remove the engine mounting shaft (see figure below).

- ◆ Remove the lower shield, see p. 20 (REMOVING THE LOWER SHIELD).
- ◆ Remove the engine, see p. 60 (REMOVING THE ENGINE FROM THE FRAME).

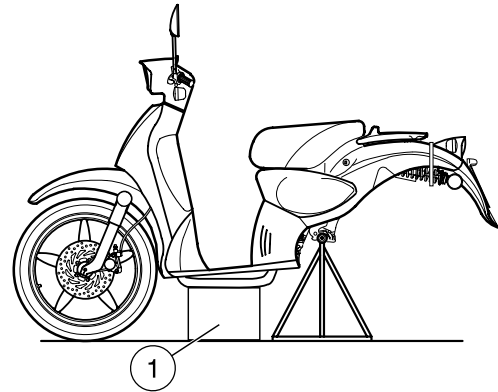

▲ WARNING

After removing the engine mounting bushings, support the vehicle chassis with the support (1).

Position a support (1) [(height 11.81 in (300 mm))] under the central part of the frame.

▲ WARNING

Make sure that the vehicle is stable. If it falls, it may injure you or bystanders, as well as damaging property, and being damaged itself.

- ◆ Remove the nut (2) and take out the frame-connecting rod fastening pin (3) from the opposite side.
- ◆ Remove the whole connecting rod (4).
- ◆ Check the condition of the silent-block (5) and buffer (6), and if damaged, replace.

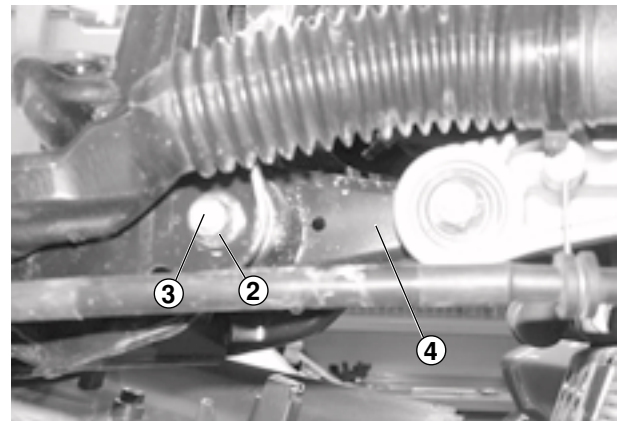

Frame-connecting rod pin locking torque: 18.08 ftlb (25 Nm)

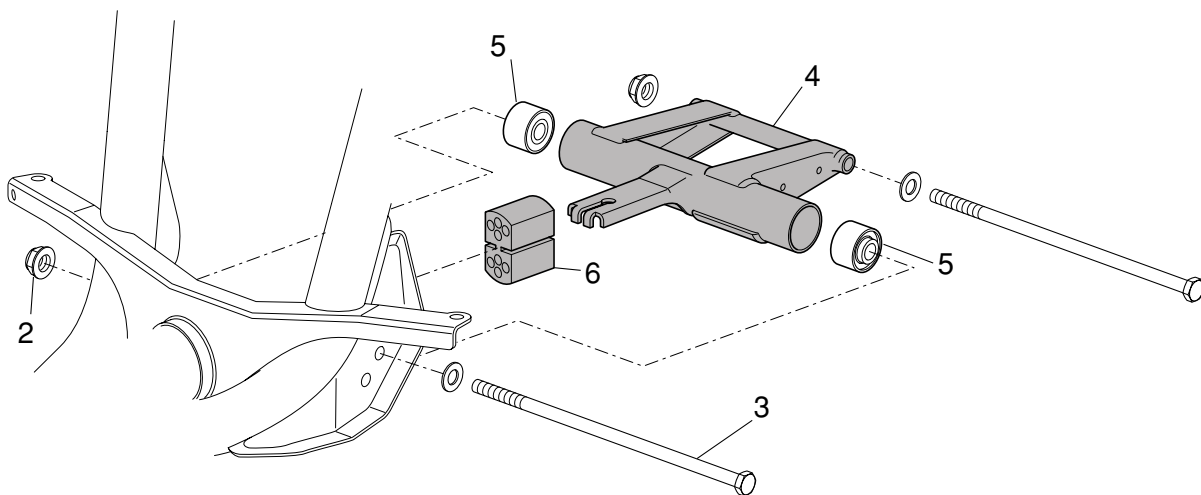

BATTERY

Carefully read p. 2 (GENERAL SAFETY RULES).

Check the electrolyte level and the tightness of the terminals after the first 312 mi (500 km) and successively every 2,500 mi (4,000 km) or 8 months.

▲ WARNING

Batteries, when charged, give off hydrogen gas, which is highly explosive. Therefore, do not smoke while working on or around the battery, and keep naked flames or sparks away from the battery. Keep gasoline and other flammable substances well away from the battery, since a battery spark could easily ignite them and cause a devastating fire.

Battery electrolyte is toxic and caustic and can severely burn your eyes or skin. Always wear tight fitting goggles and protective clothing when handling battery electrolyte. It is particularly important for you to protect your eyes since even a minuscule amount of battery acid could destroy your vision.

Should you accidentally get even the smallest amount of battery electrolyte on your skin or eyes, immediately flush with large quantities of clear cool water and immediately seek professional medical attention.

If someone should accidentally swallow battery electrolyte, drink a large quantity of milk or cool clear water and continue with milk of magnesia or vegetable oil. Seek professional medical assistance immediately.

Since the battery gives off explosive hydrogen gas, especially when it is being charged, when you are charging a battery, make sure that the room is properly ventilated. Do not inhale the gases released during charging. Do not permit any open flames, sparks or cigarettes or any other source of heat anywhere near the battery while it is charging.

KEEP BATTERIES AND ELECTROLYTE AWAY FROM CHILDREN.

▲ CAUTION

Do not tip the vehicle too much, or tip the battery too much, to avoid electrolyte leaking out. Should you accidentally spill battery electrolyte on any part of your vehicle, immediately wash it off with lots of cool clear water. Spills may be neutralized with a mixture of baking soda and water, as well. This is particularly important, as the battery electrolyte will severely corrode metallic parts and destroy the finish of plastic and painted parts.

Never invert the battery cables. Observe the proper polarity of the battery. Incorrectly attaching the battery to your vehicle will irreparably destroy the electrical system of your vehicle.

Connect and disconnect the battery only with the ignition switch (1) in the "⊗" (OFF) position.

First connect the positive cable (red) (+), then the negative (-).

Disconnect the negative cable (-) first, then the positive (red) (+).

If your battery needs to be charged, use a constant voltage, or "taper" charger, with a current rating no greater than 1/10th the capacity of the battery (i.e., for a 50 amp hour battery, the maximum charging current should be 5 amps). Use of a more powerful charger can not only damage the battery irreparably, but could cause it to overheat and explode.

If your battery is equipped with an overflow tube, always ensure that it is properly installed, and properly routed. Failure to adhere to this instruction can cause corrosive fumes from the battery to cause serious damage to your vehicle.

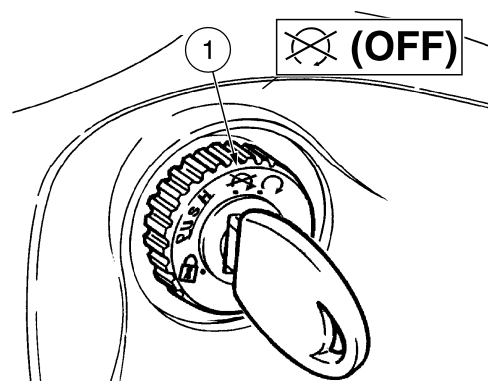
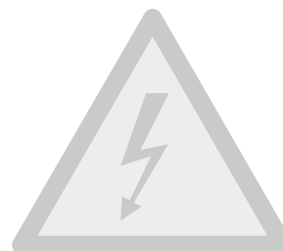

CHECKING AND CLEANING TERMINALS AND CLAMPS

Carefully read p. 63 (BATTERY).

- ◆ Access the battery, see page 64 (ACCESSING THE BATTERY).
- ◆ Check that the cable terminals (2) and battery clamps (3) are:
 - in good condition (not corroded or covered with deposits);
 - coated with special grease or Vaseline.

If necessary:

- ◆ Make sure that the ignition switch (1) is set to "⊗".
- ◆ Disconnect, in this sequence, the negative cable (-) and the positive cable (red) (+).
- ◆ Use a wire brush to remove all traces of corrosion.
- ◆ Reconnect, in this sequence, the positive cable (red) (+) and the negative cable (-).
- ◆ Coat the terminals and clamps with special grease or Vaseline.
- ◆ Replace the battery, see page 66 (BATTERY INSTALLATION).

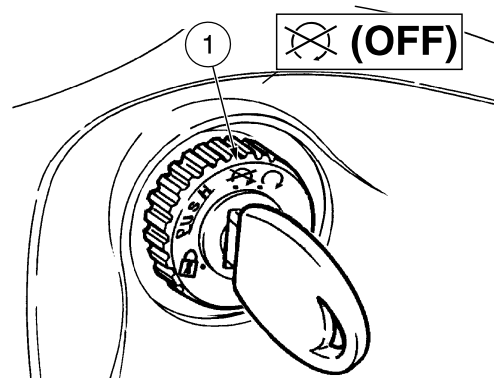
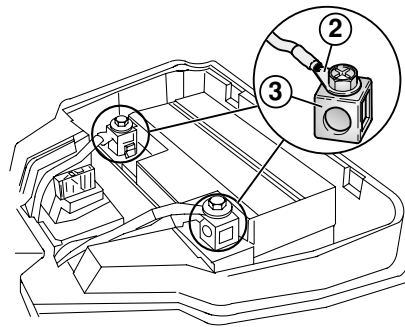

REMOVING THE BATTERY

Carefully read p. 63 (BATTERY).

ACCESSING THE BATTERY

- ◆ Make sure that the ignition switch is set to "⊗".
- ◆ Lift up the saddle.
- ◆ Remove the battery cover (4).

▲ CAUTION

The battery is connected to the electrical cables.
Do not pull on the cables when removing it.

REMOVING COMPLETELY

- ◆ Disconnect, in this sequence, the negative cable (-) and the positive cable (red) (+).
- ◆ Disconnect the bleeder pipe.
- ◆ Remove the battery from its housing and place it on a flat surface in a cool, dry place.

▲ WARNING

After removing the battery, store it in a safe place well out of the reach of children.

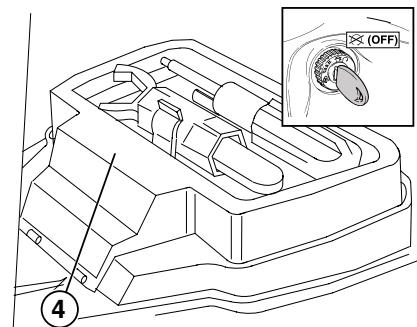

CHECKING THE ELECTROLYTE LEVEL

Carefully read p. 63 (BATTERY).

Your vehicle is equipped with a sealed maintenance free battery that does not require the check of the level battery.

RECHARGING THE BATTERY

Carefully read p. 63 (BATTERY).

▲ WARNING

This battery is completely sealed. Do not attempt to remove the caps.

There is never any need to add water to this battery. Attempting to remove the caps will destroy the battery and could lead to injury through the spillage of caustic electrolyte. Recharge the battery according to the table below.

- ◆ Remove the battery, see p. 64 (REMOVING THE BATTERY).

▲ WARNING

The battery gives off noxious and explosive gases; keep it away from flames, sparks, cigarettes and any other source of heat.

During recharging or use, make sure that the room is properly ventilated and avoid inhaling the gases released during the recharging.

- ◆ Connect the battery charger to the battery.
- ◆ Charge the battery using a battery charger with current capacity of no greater than 1/10th the capacity of the battery, see p. 9 (TECHNICAL DATA).
- ◆ Switch on the battery charger.

▲ WARNING

Wait for 5 or 10 minutes after you have finished charging the battery before re-installing it, the battery continues to produce gas for a short period of time after the charger is removed.

INSTALLING THE BATTERY

Carefully read p. 63 (BATTERY).

- ◆ Make sure that the ignition switch (1) is set to "OFF".
- ◆ Position the battery in its housing.
- ◆ Connect up the battery bleeder pipe.

▲ CAUTION

Always connect the battery bleeder pipe, to prevent any sulfuric acid fumes produced by the battery from corroding the electrical system, paintwork, rubber elements or gaskets.

The bleeder pipe must be connected in such a way that it is not crushed, otherwise this might cause an increase in pressure inside the battery, which may damage it.

- ◆ First connect up the positive cable (red) (+) and then the negative one (-).
- ◆ Coat the terminals and clamps with special grease or Vaseline.

▲ CAUTION

When reassembling, the electrical cables must be fed into a position in which they are not crushed in any way.

The negative cable (-) must not cross the positive terminal (+), but must be positioned to the side, between the battery and the holder.

- ◆ Push the battery into the battery holder.
- ◆ Close the battery cover (2).
- ◆ Lower the saddle.

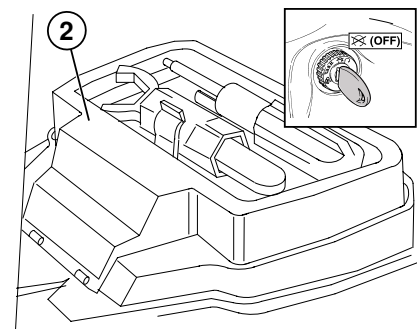
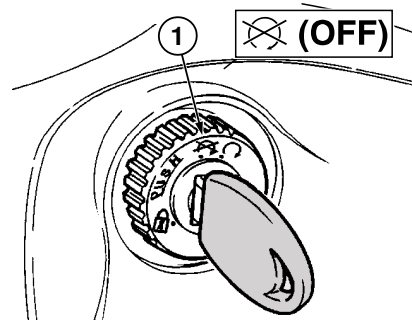

CHANGING FUSES

▲ CAUTION

Do not repair faulty fuses.
Use only recommended fuses.
Using fuses of an improper capacity can cause damage to the electrical system or an electrical fire, which could result in total destruction of your vehicle as well as injury to you.

NOTE If a fuse blows frequently, there probably is a short circuit or an overload in the electrical system. If this occurs, take the vehicle to your Local aprilia Dealer.

If an electric component does not work or works irregularly, or if the vehicle fails to start, it is necessary to check the fuse (1).

To check the fuse:

- ◆ Turn the ignition switch (2) in the "⊗" (OFF) position.
- ◆ Remove the inspection cover, see p. 19 (REMOVING THE INSPECTION COVER).
- ◆ Remove the fuse (1) and inspect the filament (3). If it is open, the fuse must be replaced.
- ◆ Replace the blown fuse with the spare fuse (4), or with a new fuse having the same amperage rating.

▲ WARNING

If you replace the fuse and it blows again immediately, there is a serious problem with the electrical system of your vehicle. Do not attempt to continue using your vehicle. Take it to your Local aprilia Dealer for repair and service.

NOTE If you use the spare fuse (4), replace it as soon as convenient.

FUSE CIRCUIT

A 7.5 amp fuse protects all of the electrical loads except the lighting circuit, which is fed with alternating current directly from the alternator.

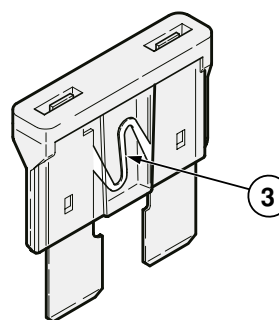
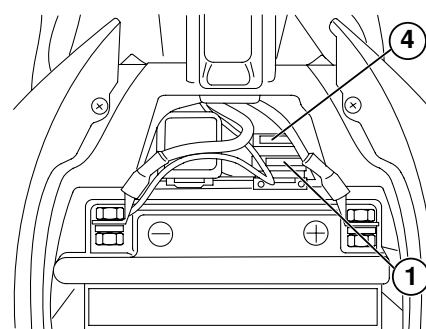
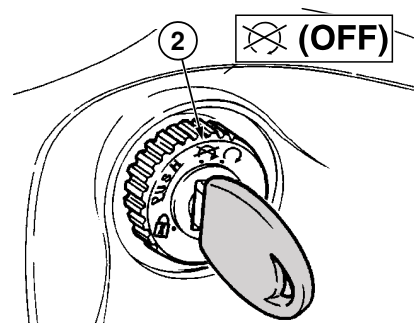

ELECTRICAL SYSTEM

CONTENTS

Recharge and general power supply circuit 67
Injection power 68
Injection diagram 69
Stoplight circuit and starter circuit 73
Direction indicator circuit and horn circuit 75
Lighting circuit 76
Dashboard lights circuit 77
Wiring diagrams 80
Arrangement of the components 82
Arrangement and fastening of cables and wiring 84
Fastening of cables and wiring 86

RECHARGE AND GENERAL POWER SUPPLY CIRCUIT

WIRING DIAGRAM

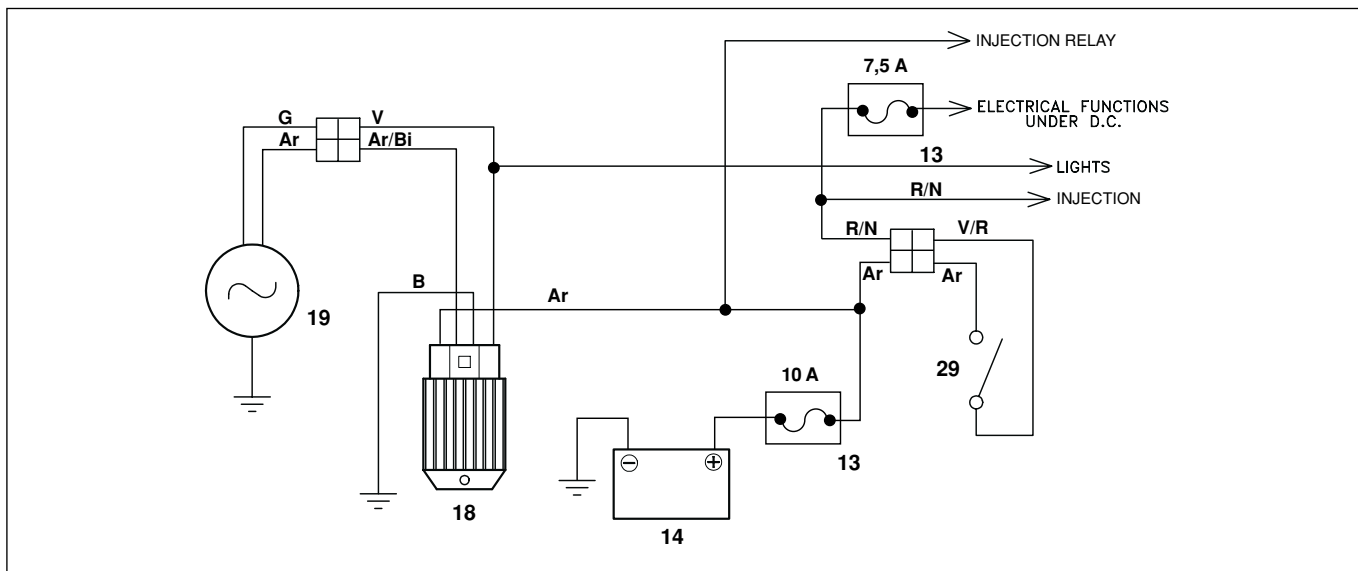

Arrangement of the components: see p. 82 - 83.

- 13) Fuses
- 14) Battery
- 18) Voltage regulator
- 19) Generator
- 29) Steering lock

- battery and fuse.
- Check the battery.
- Check the generator.
- Check the ignition switch and its connections.

D. IF THE SYSTEM FUNCTIONS IRREGULARLY

- Check the earth connections.

TECHNICAL DATA

Generator	140W
Voltage regulator	12 V a.c.
Battery	4 Ah - 12V sealed
Fuse	10 A

CHECKING THE CHARGING SYSTEM

- Start the engine.
- Using the voltmeter function of the multimeter, connect the positive lead to the positive terminal of the battery, and the negative lead to the negative terminal of the battery.
- At 6,000 rpm voltage must be included between 13.5 and 15 V.

TROUBLESHOOTING

A. INSUFFICIENT RECHARGE VOLTAGE

- Check the fuse and, if necessary, replace it.
- Check the cable connections on regulator, flywheel, battery and fuse.
- Check the battery.
- Check the generator.

B. EXCESSIVE RECHARGE VOLTAGE

- Check the voltage regulator.
- Check the cable connections.

C. IF NO VOLTAGE REACHES THE LOADS UNDER DIRECT CURRENT (green/red cables)

- Check the fuse and if necessary replace it.
- Check the ground connections on regulator, flywheel,

TEST DATA

GENERATOR

- Disconnect the two-way connector from the generator.
- Start the engine and bring it to 6,000 rpm.
- Using the alternating current function of the multimeter, measure the voltage between:
 - orange cable and generator earth = value over 41.2 V.
 - yellow/red cable and generator earth = value over 35V.
- Using the alternating current ammeter function of the multimeter, measure the current between:
 - orange cable and generator earth = value 8 - 10 A.
 - yellow/orange cable and generator earth = value 8 - 10 A.

BATTERY

- No-load voltage 12.5 ± 1V.
- Electrolyte density 1.26 at 20 °C.
- Check the electrolyte level and if necessary top up with distilled water.
- Make sure that there are no signs of sulphation. Replace if necessary.

INJECTION POWER

WIRING DIAGRAM

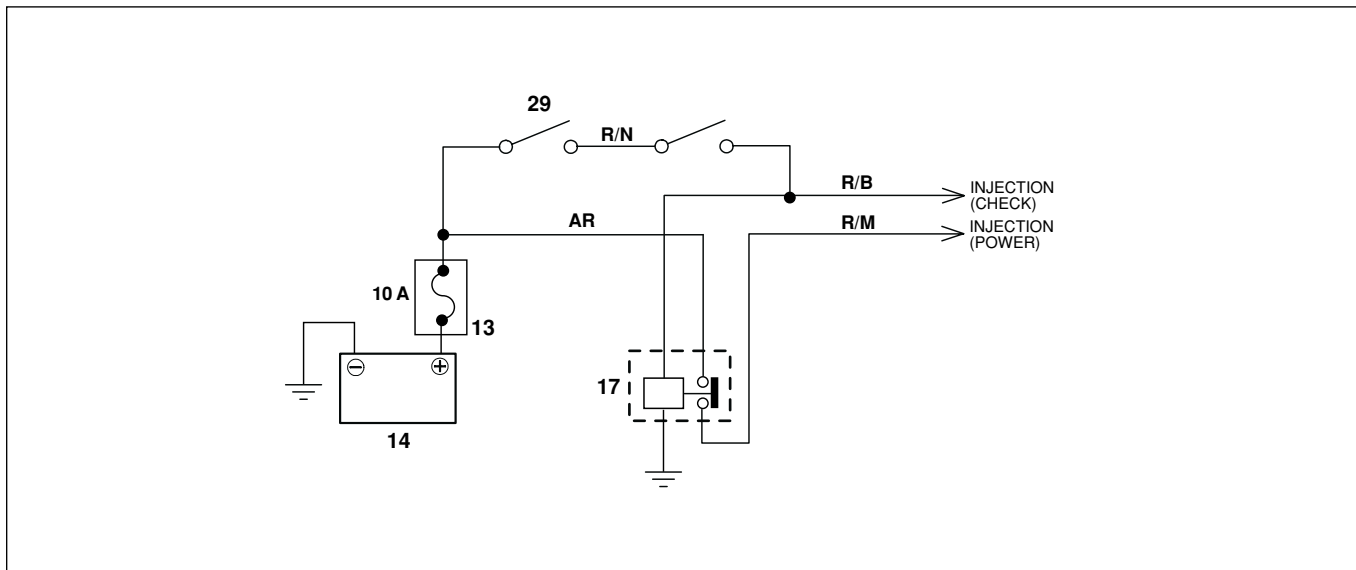

Arrangement of the components: see p. 82 - 83.

- 13) Fuses
- 14) Battery
- 17) Injection relay
- 29) Steering lock

TROUBLESHOOTING

- Check the condition of the 10A fuse.
- Check the efficiency of the key (see switches section).
- Check the efficiency of the KILL SWITCH (USA version only) (see switches section).
- Check the efficiency of the injection relay switch.

CHECKING THE INJECTION RELAY

To check the efficiency of the relay switch:

- Disconnect the (white) 4-way connector (4) of the relay (5).

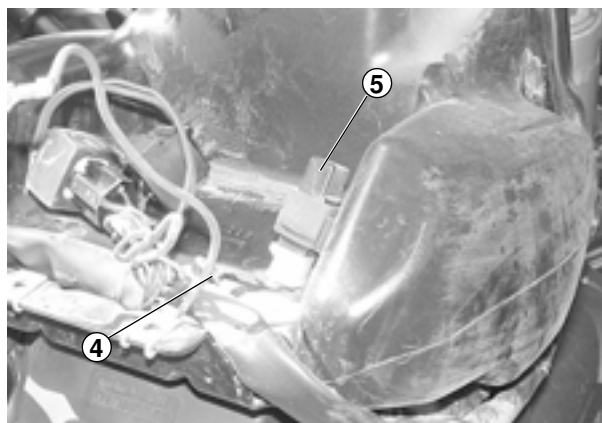

⚠ WARNING

Upon reassembly, make sure that the electric connector (4) is correctly coupled.

- Energize (12V) the two internal male terminals (1 - 2).
- Using an ohmmeter-tester, check the continuity between the other two terminals (3 - 5).

Correct value with relay energized: 0 Ω
Correct value with relay not energized: ∞ Ω

If the values do not correspond to those given above, replace the relay switch.

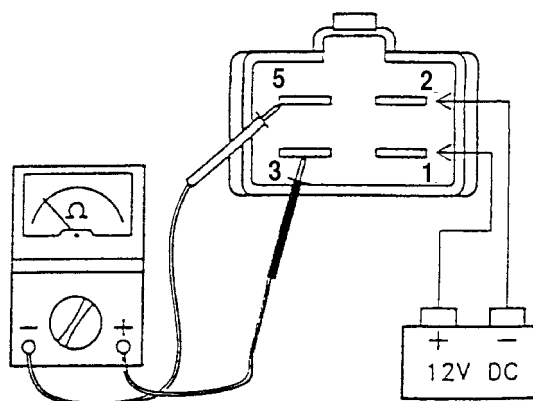

INJECTION DIAGRAM

WIRING DIAGRAM

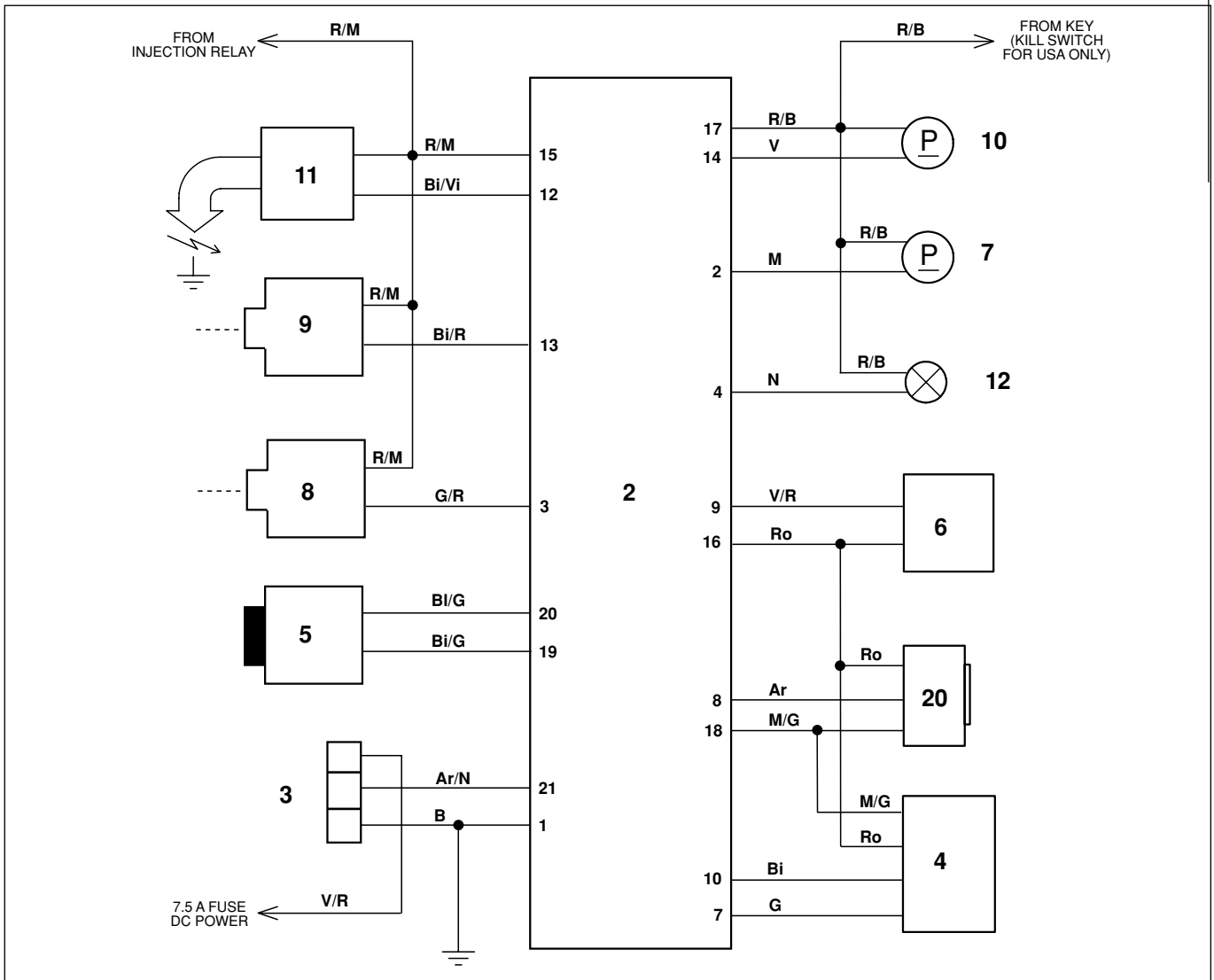

Arrangement of the components: see p. 82 - 83.

- 2) CDI
- 3) Serial connection
- 4) Throttle sensor
- 5) Pick-up
- 6) Temperature sensor
- 7) Oil pump
- 8) Fuel injector
- 9) Air injector
- 10) Fuel pump
- 11) H.T. coil
- 12) Spark plug
- 20) Pressure sensor (not fitted as standard)
- 34) Injection check warning light

TROUBLESHOOTING

- Check the efficiency of the spark plug cap.
- Using an ohmmeter-tester, check the coil primary and secondary values:
 between the two terminals for the connector $0.7\text{ k}\Omega \pm 20\%$
 between the HT cable and the coil casing $7.1\text{ k}\Omega \pm 20\%$

NOTE Before taking this reading, disconnect the spark plug cap.

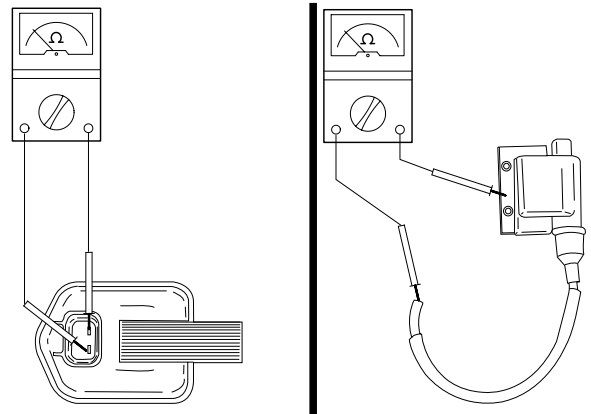

CHECKING THE AIR INJECTOR

- Using an ohmmeter-tester, check the resistance values between the two terminals from the injector side (1).

Correct value: $1.3\ \Omega$

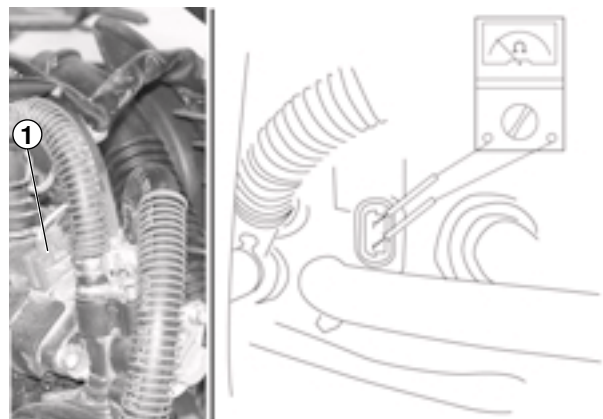

CHECKING THE FUEL INJECTOR

- Using an ohmmeter-tester, check the resistance values between the two terminals from the injector side (1).

Correct value: $1.8\ \Omega$

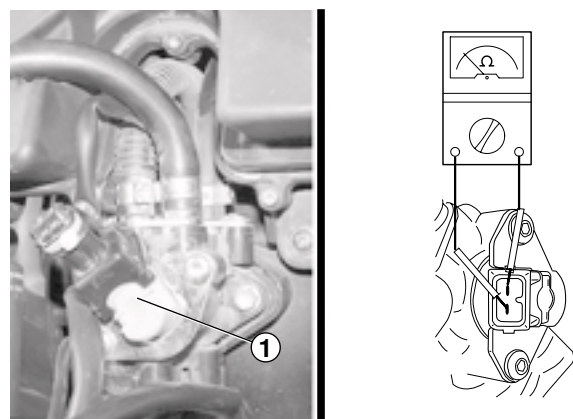

CHECKING THE PICK-UP

- Using an ohmmeter-tester, check the resistance values between the two terminals from the pick-up side.

Correct value: $385 \Omega \pm 20\%$

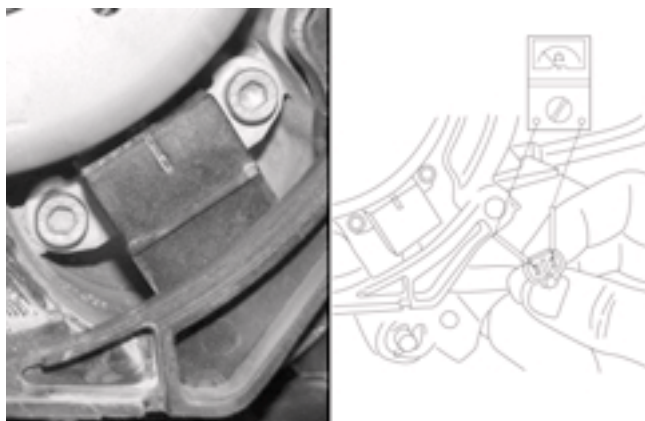
**CHECKING THE FUEL PUMP**

- Energize the pump (12VDC), taking care to respect polarity, and check that the resulting fuel flow is sufficient

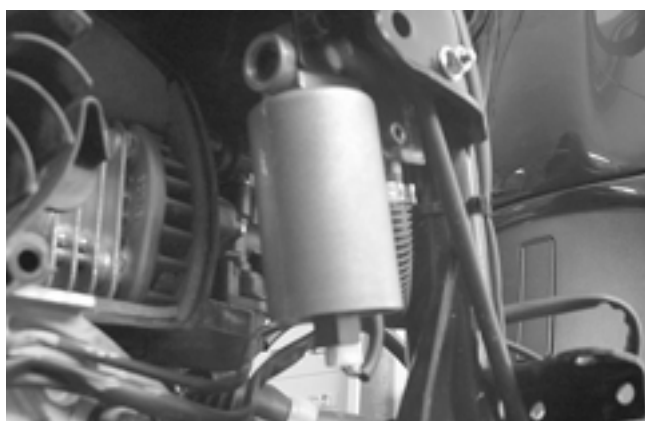
**CHECKING THE OIL PUMP**

- Using an ohmmeter-tester, check the resistance values between the two terminals from the pump side.

Correct value: $26.5 \Omega \pm 20\%$

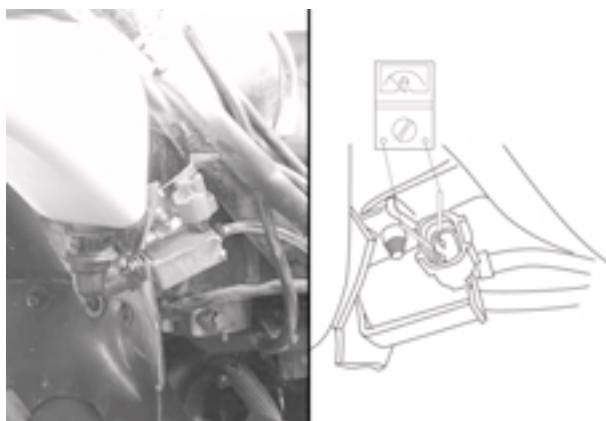
**CHECKING THE THROTTLE SENSOR**

- Using an ohmmeter-tester, check the resistance values between the various terminals from the sensor side, after first disconnecting the connector:



– With throttle CLOSED.

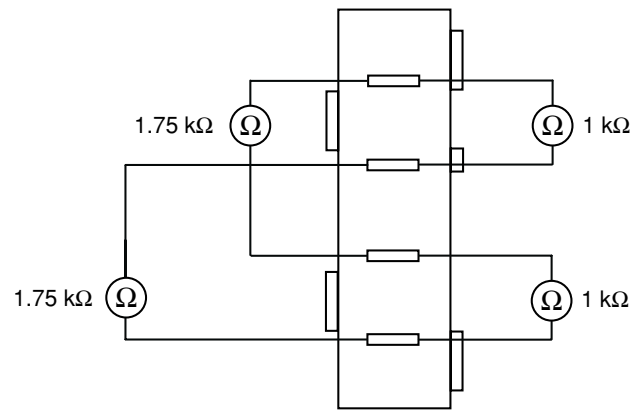

– With throttle OPEN.

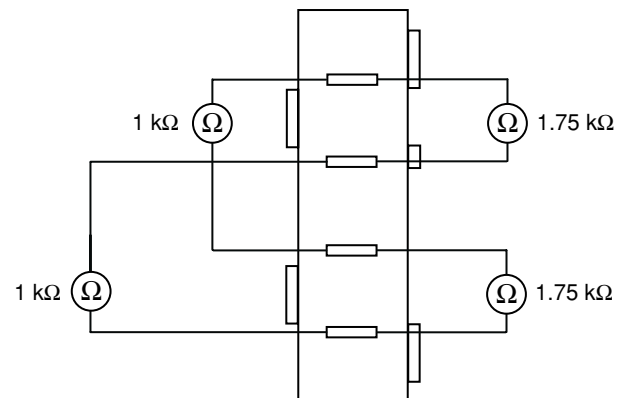

CHECKING THE ATMOSPHERIC PRESSURE SENSOR

– Special equipment is required to check this element. Try replacing the sensor with a new and operational one.



CHECKING THE TEMPERATURE SENSOR

– Disconnect the connector and use an ohmmeter to measure the resistance between the two terminals from the sensor side.

A 25° C = 11.150 kΩ ± 10%
 A 100° C = 800 Ω ± 10%

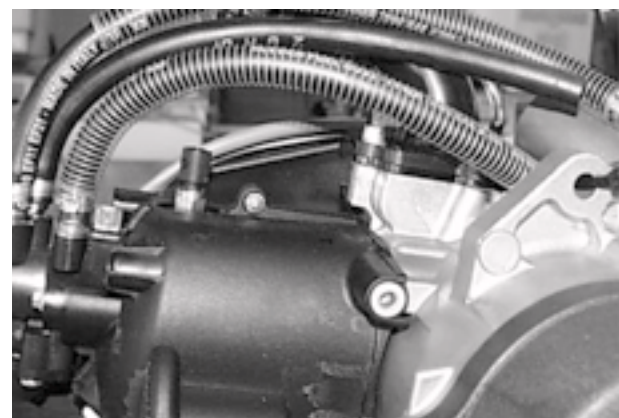

STOPLIGHT CIRCUIT AND STARTER CIRCUIT

WIRING DIAGRAM

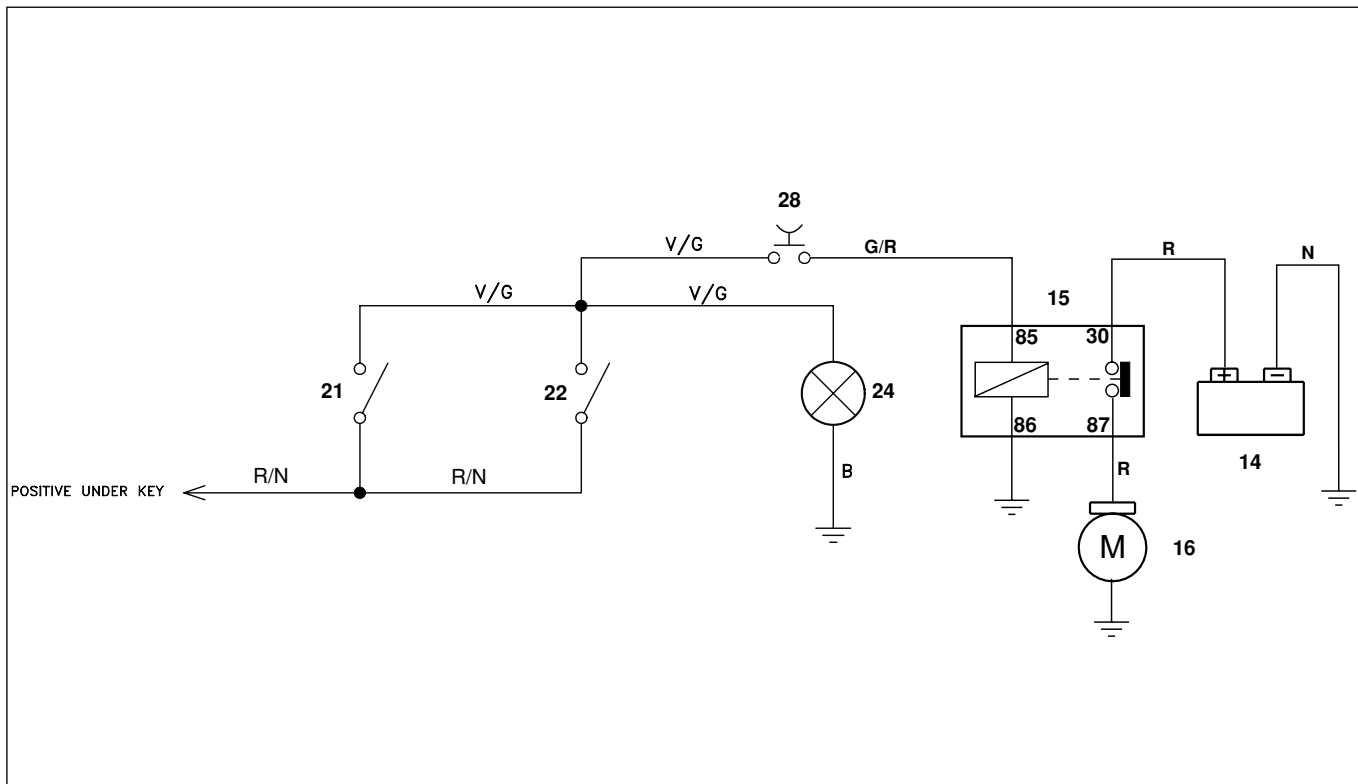

Arrangement of the components: see p. 82 - 83.

- 14) Battery
- 15) Start relay
- 16) Starter motor
- 21) Front stoplight switch
- 22) Rear stoplight switch
- 24) Rear parking light / stoplight bulb
- 28) Starter switch

TECHNICAL DATA

Rear parking light / stoplight bulb 12 V - 5/21 W

- Check the front stoplight switch.
- Check the rear stoplight switch.

TEST DATA

FRONT AND REAR STOPLIGHT SWITCH

- Disconnect the switch cables.
- Put on the brake and, using an ohmmeter-tester, check the resistance between the two cables on the connector:
Normal value with pulled brake: 0 Ω.
Normal value with released brake: infinite resistance.
- Checking the starter switch (see switches section).

TROUBLESHOOTING

A. STOPLIGHT ALWAYS ON

- Check the rear light connections.
- Check the front stoplight switch.
- Check the rear stoplight switch.

B. STOPLIGHT DOESN'T COME ON

- Check the bulb and the bulb socket.
- Check the cable connections.
- Check the general power supply circuit.

CHECKING THE START RELAY

To check the efficiency of the relay switch:

- Energize (12 V) the two male terminals (85 - 86).
- Using an ohmmeter-tester, check the continuity between the other two terminals (87 - 30).

Correct value with relay energized: 0 Ω

Correct value with relay not energized: ∞ Ω

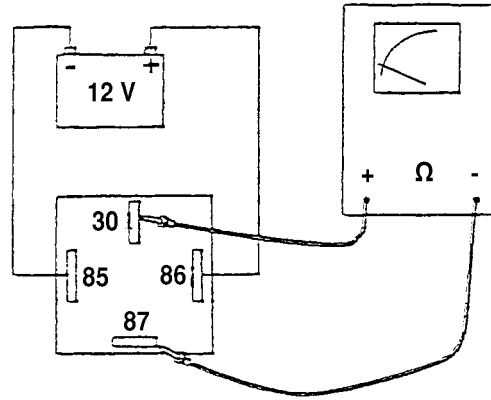

CHECKING THE STARTER MOTOR

Directly energize the starter motor (12 VDC).

The starter motor should start up and cause the engine to run, absorbing a current of 20 - 25 A.

If the starter motor does not start up, check and if necessary, replace the brushes.

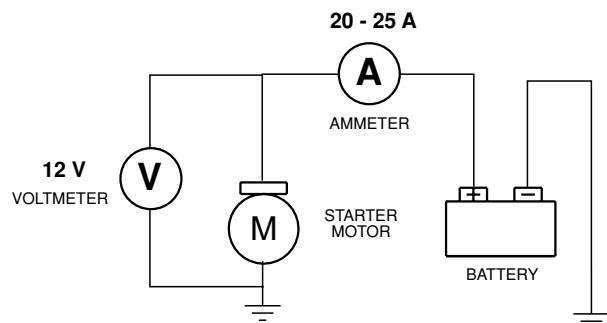

DIRECTION INDICATOR CIRCUIT AND HORN CIRCUIT

WIRING DIAGRAM

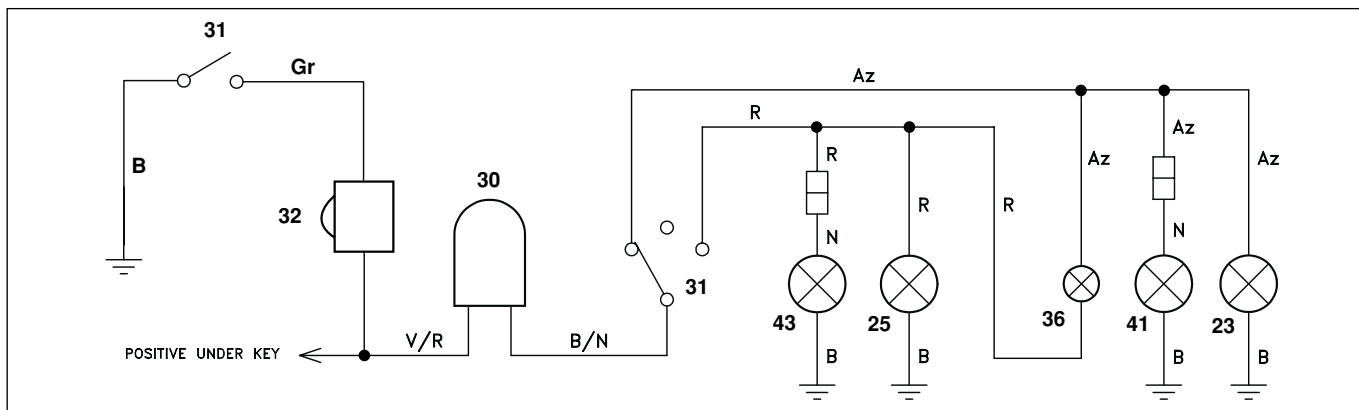

Arrangement of the components: see p. 82 - 83.

- 23) Rear left direction indicator
- 25) Rear right direction indicator
- 30) Flasher
- 31) Left dimmer switch
- 32) Horn
- 36) Direction indicator warning light
- 41) Front left direction indicator
- 43) Front right direction indicator

TECHNICAL DATA

Direction indicator bulbs 12 V - 10 W B.A. 15 S
 Flasher 12 V - 22 W
 Direction indicator warning light
 bulb-"all-glass" 12 V - 3 W - W2x4.6 d

TECHNICAL DATA

Horn 12 V d.c.

TROUBLESHOOTING

A. DIRECTION INDICATORS DON'T WORK

- Check the bulbs.
- Check the cable connections.
- Check the direction indicator switch (left dimmer switch).
- Check the main power supply circuit.
- Replace the flasher.

B. DIRECTION INDICATORS DON'T FLASH, BUT ARE ALWAYS ON

- Check the technical data of the bulbs.
- Check the battery.
- Replace the flasher.

TEST DATA

DIRECTION INDICATOR SWITCH

- Check the bulb efficiency.
- Disconnect the left dimmer switch connector.
- Using the ohmmeter function of the multimeter, check the continuity among the cables in the various positions, according to the connections, see (WIRING DIAGRAM).

TROUBLESHOOTING

A. HORN DOES NOT SOUND OR IS IRREGULAR

- Check the battery.
- Check the cable connections.
- Check the horn push button.
- Check the horn.

B. HORN KEEPS SOUNDING

- Check the cable connections.
- Check the horn push button.

TEST DATA

HORN

- Disconnect the horn and power it directly with a 12 V battery.
- If necessary, adjust the horn adjuster in and out until a satisfactory note is obtained.

HORN PUSH BUTTON

- Disconnect the left dimmer switch connector.
- Using the ohmmeter function of the multimeter, check the continuity between the contacts in the "pressed" and "released" positions, see (WIRING DIAGRAM).

LIGHTING CIRCUIT

WIRING DIAGRAM

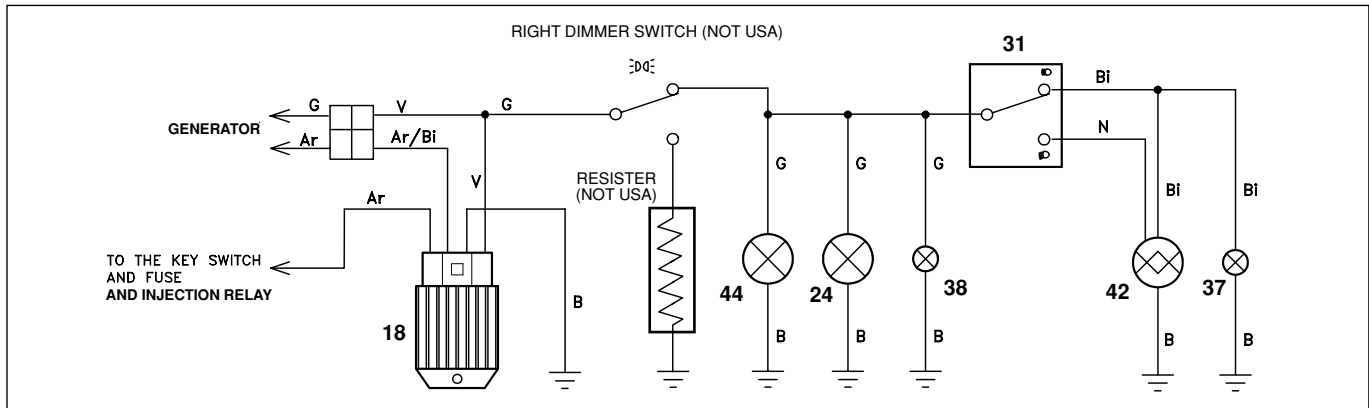

Arrangement of the components: see p. 82 - 83.

- 18) Voltage regulator
- 24) Rear parking light/stoptight bulb
- 31) Left dimmer switch
- 37) High beam warning light
- 38) Dashboard light
- 42) High/low beam bulb
- 44) License plate lamp

TECHNICAL DATA

- Low/high beam bulb 12V - 35/35 W
- Rear parking light/stoptight bulb 12V- 5/21 W
- Dashboard bulbs "all-glass" 12V-1.2 W - W2x4.6 d
- High beam warning light "all-glass" 12V-1.2W W2x4.6 d
- License plate light bulb 12V-5W

TROUBLESHOOTING

A. ONE BULB DOESN'T WORK

- Check the bulb.
- Make sure that there is voltage on the bulb socket terminals.
- Check the harness connections.

B. NO BULB WORKS

- Check the voltage regulator.
- Check the generator.

C. BULBS CUT OUT FREQUENTLY

- Make sure that the lights do not vibrate excessively and do not get in contact with the parts of the vehicle which aren't elastically supported.
- Check the cable connections.
- Check the voltage regulator.

TEST DATA

VOLTAGE REGULATOR

Change the voltage regulator with a new one.

DASHBOARD LIGHT CIRCUIT

WIRING DIAGRAM

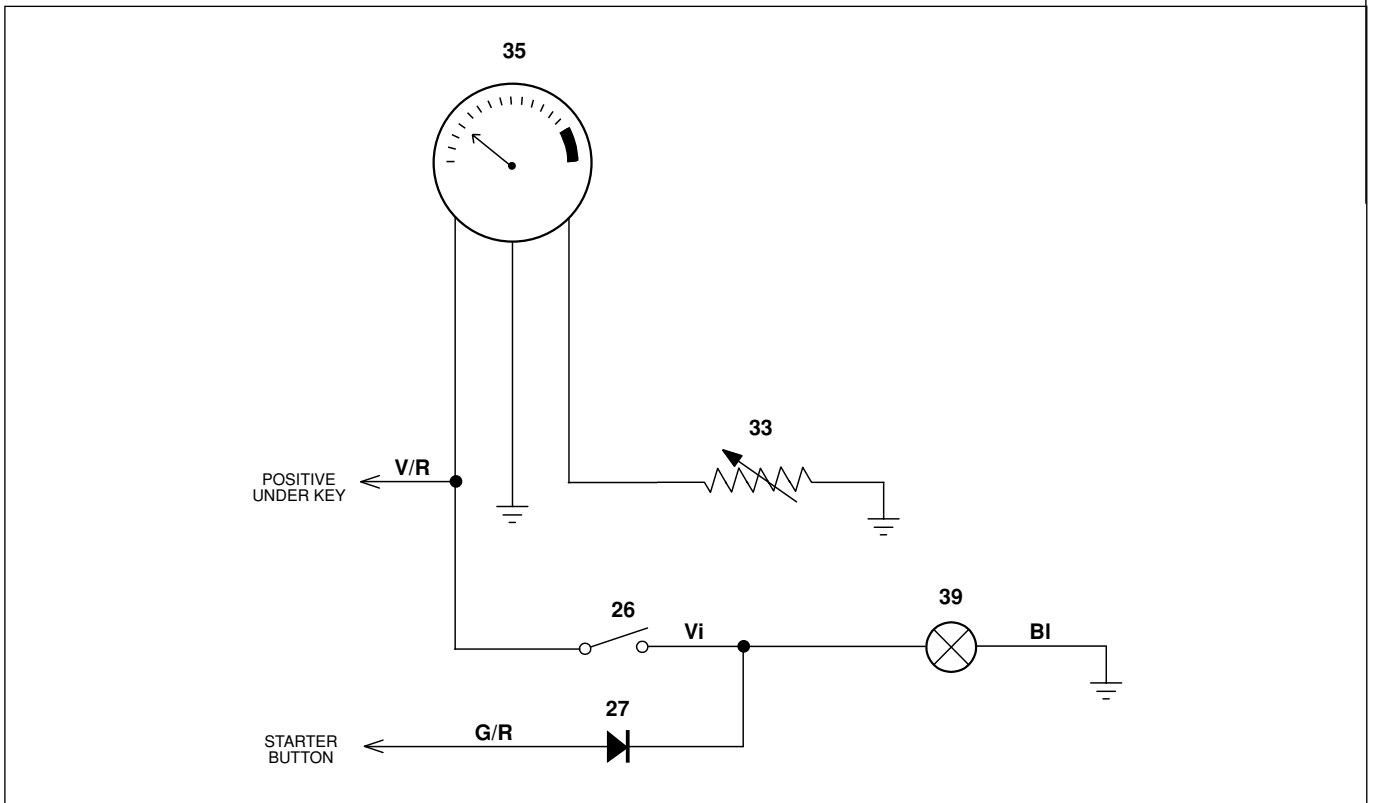

Arrangement of the components: see p. 82 - 83.

- 26) Oil level switch
- 27) Control diode
- 33) Fuel level sensor
- 35) Fuel level device
- 39) Oil level warning light

FUEL LEVEL INDICATOR**TROUBLESHOOTING****A. INSTRUMENT ALWAYS INDICATES 0 EVEN WITH FULL TANK**

- Make sure that there is voltage between the green/red and the blue cable of the instrument.
- Check the cable connections.
- Make sure that the gray/green cable isn't open between the instrument and the sensor.
- Check the instrument.
- Check the sensor.

B. INSTRUMENT ALWAYS INDICATES "FULL" EVEN WITH EMPTY TANK

- Make sure that the gray/green cable is not grounded.
- Check the instrument.
- Check the sensor.

TEST DATA**INSTRUMENT**

- Disconnect the two-way connector of the sensor.
- Connect a $5 \Omega \pm 10\%$ - 2 W resistance between the gray/green and the blue cable on the main system side.
- If the battery has $13 \text{ V} \pm 0.5 \text{ V}$, the instrument should read "4/4".
- Connect a 100Ω - 2 W resistance between the gray/green and the blue cable on the main system side.
- If the battery has $13.5 \text{ V} \pm 0.5 \text{ V}$, the instrument should read "0".

SENSOR

- Make sure that on the two-way connector the entering and exiting cables have the same colours.
- Remove the sensor from the tank.
- Disconnect the two-way connector of the sensor and carry out the following measurements on the sensor side.
- Using the ohmmeter function of the multimeter, measure the following resistances:
 - With sensor in vertical position:
between gray/green and blue cable, correct value $\geq 90 \Omega$.
 - With sensor inverted:
between gray/green and blue cable, correct value $10 \leq \Omega$.

TECHNICAL DATA

"All-glass" 2 stroke oil reserve

warning light bulb 12 V - 1.2W, W2x4.6 d

2 STROKE OIL RESERVE WARNING LIGHT

The 2 stroke oil reserve warning light comes on every time the engine is started, to make sure that the bulb functions correctly.

TROUBLESHOOTING

A. WARNING LIGHT DOESN'T COME ON WHEN OIL LEVEL IS INSUFFICIENT

- Check the bulb.
- Make sure that there is voltage on the green/red cable of the 2 stroke oil level sensor.
- Check the cable connections.
- Check the 2 stroke oil level sensor.

B. WARNING LIGHT REMAINS ON EVEN IF OIL LEVEL IS SUFFICIENT

- Check the cable connections.
- Check the 2 stroke oil level sensor.

CONTROL DATA

CHECKING THE 2 STROKE OIL LEVEL SENSOR

- Disconnect the cables which connect it to the system and remove it from the tank.
- Using the ohmmeter function of the multimeter, attach the multimeter leads to the sensor cables.
- When the sensor is in the vertical position, it should show a short circuit, that is, less than 0.1Ω .
- In the reverse position, it should show an open, that is, infinite resistance.

CONTROL DIODE

- Disconnect it from the system.
- Using the diode testing function of the multimeter, connect it as shown in the figure.

Correct value (measure A): $0 \div 1$

Correct value (measure B): ∞

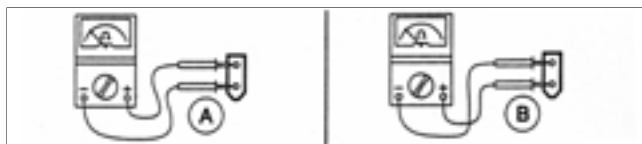

If the tester does not include the diode test function, use a 12V battery and a 12V - 2W bulb, connecting the diode as indicated in the figure.

▲ CAUTION

Do not use bulbs over 2W, since the diode may be damaged.

Test (C): the bulb does not light up.

Test (D): the bulb lights up.

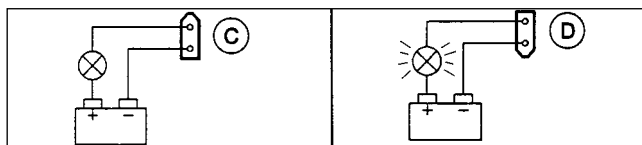

WIRING DIAGRAM - SCARABEO 50 USA

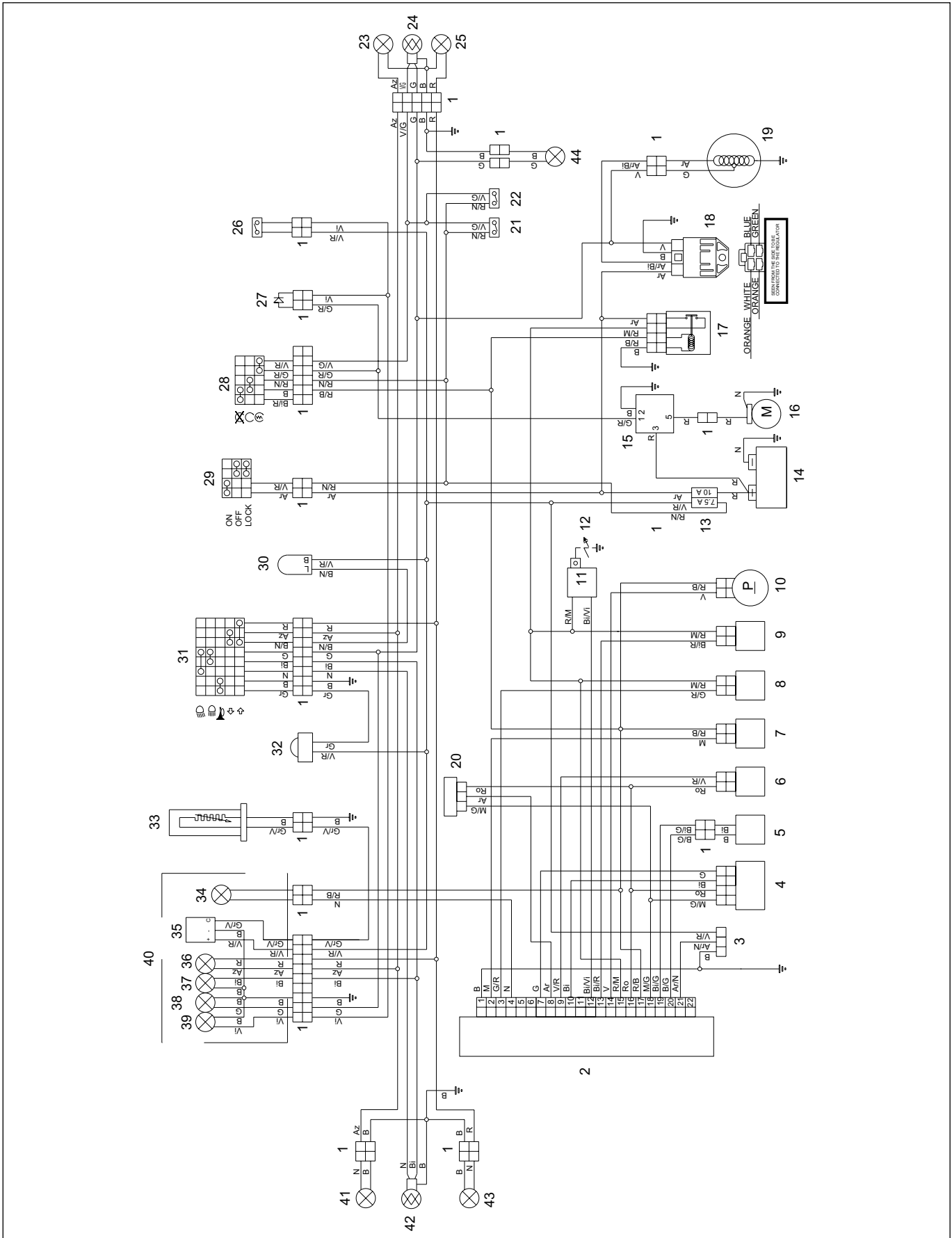

Wiring diagram key

- 1) Multiple connectors
- 2) CDI
- 3) Serial connection
- 4) Throttle sensor
- 5) Pick-up
- 6) Temperature sensor
- 7) Oil pump
- 8) Fuel injector
- 9) Air injector
- 10) Fuel pump
- 11) H.T. coil
- 12) Spark plug
- 13) Fuses
- 14) Battery
- 15) Start relay
- 16) Starter motor
- 17) Injection relay
- 18) Voltage regulator
- 19) Generator
- 20) Pressure sensor (not fitted as standard)
- 21) Front stoplight switch
- 22) Rear stoplight switch
- 23) Rear left direction indicator
- 24) Rear parking light / stoplight bulb
- 25) Rear right direction indicator
- 26) Oil level switch
- 27) Control diode
- 28) Right dimmer switch
- 29) Steering lock
- 30) Flasher
- 31) Left dimmer switch
- 32) Horn
- 33) Fuel level sensor
- 34) Injection check warning light
- 35) Fuel level device
- 36) Direction indicator warning light
- 37) High beam warning light
- 38) Dashboard light
- 39) Oil level warning light
- 40) Dashboard
- 41) Front left direction indicator
- 42) High/low beam bulb (35/35W)
- 43) Front right direction indicator
- 44) License plate lamp

CABLE COLOURS

- | | |
|-----------|------------|
| Ar | orange |
| Az | light blue |
| B | blue |
| Bi | white |
| G | yellow |
| Gr | gray |
| M | brown |
| N | black |
| R | red |
| V | green |
| Vi | violet |
| Ro | pink |

ARRANGEMENT OF THE COMPONENTS

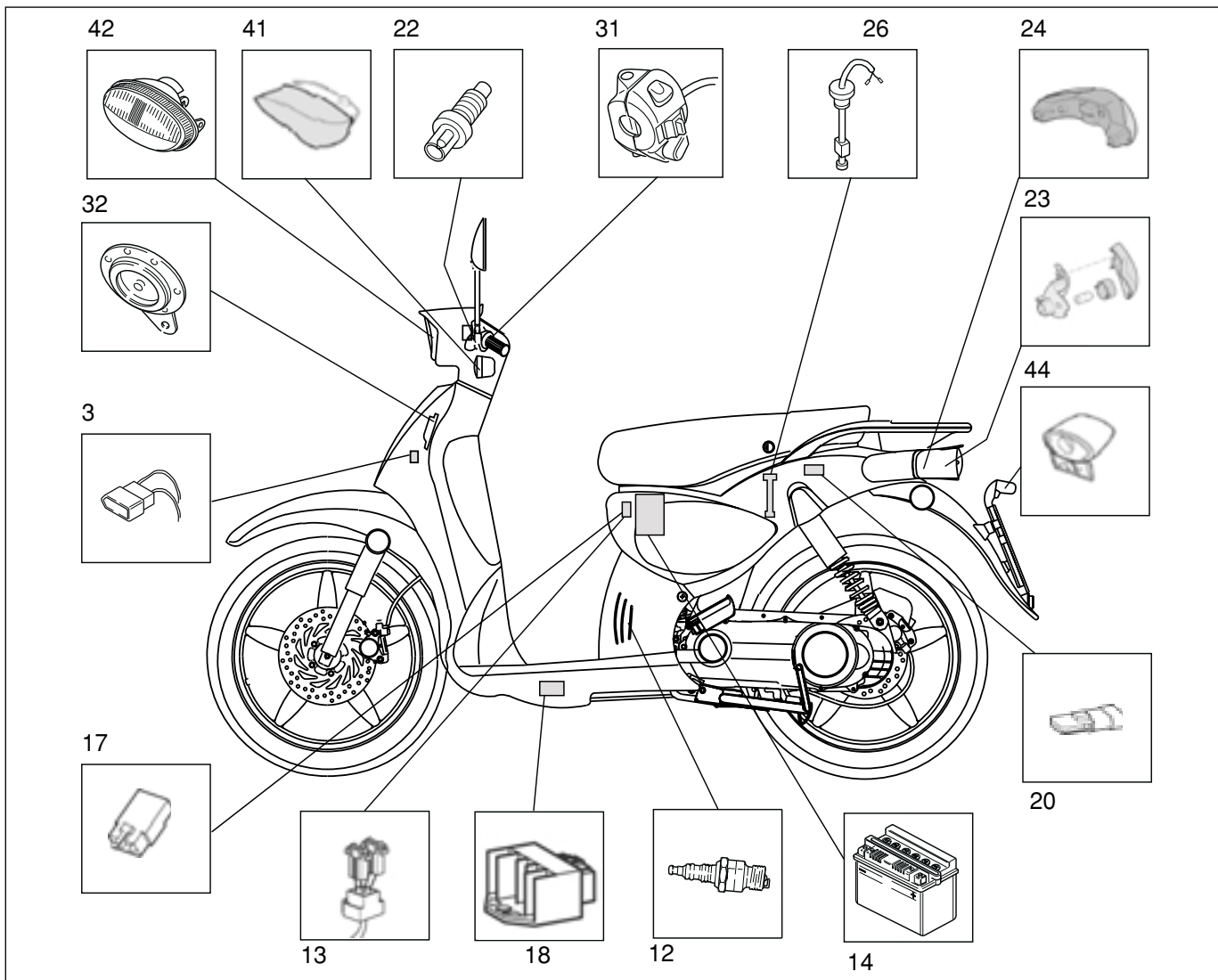

KEY

- 3) Serial connection
- 12) Spark plug
- 13) Fuses
- 14) Battery
- 17) Injection relay
- 18) Voltage regulator
- 20) Pressure sensor (not fitted as standard)
- 22) Rear stoplight switch
- 23) Rear left direction indicator
- 24) Rear parking/brake lamp
- 26) Oil level switch
- 31) Left dimmer switch
- 32) Horn
- 41) Front left direction indicator
- 42) High/low beam bulb (35/35W)
- 44) License plate lamp

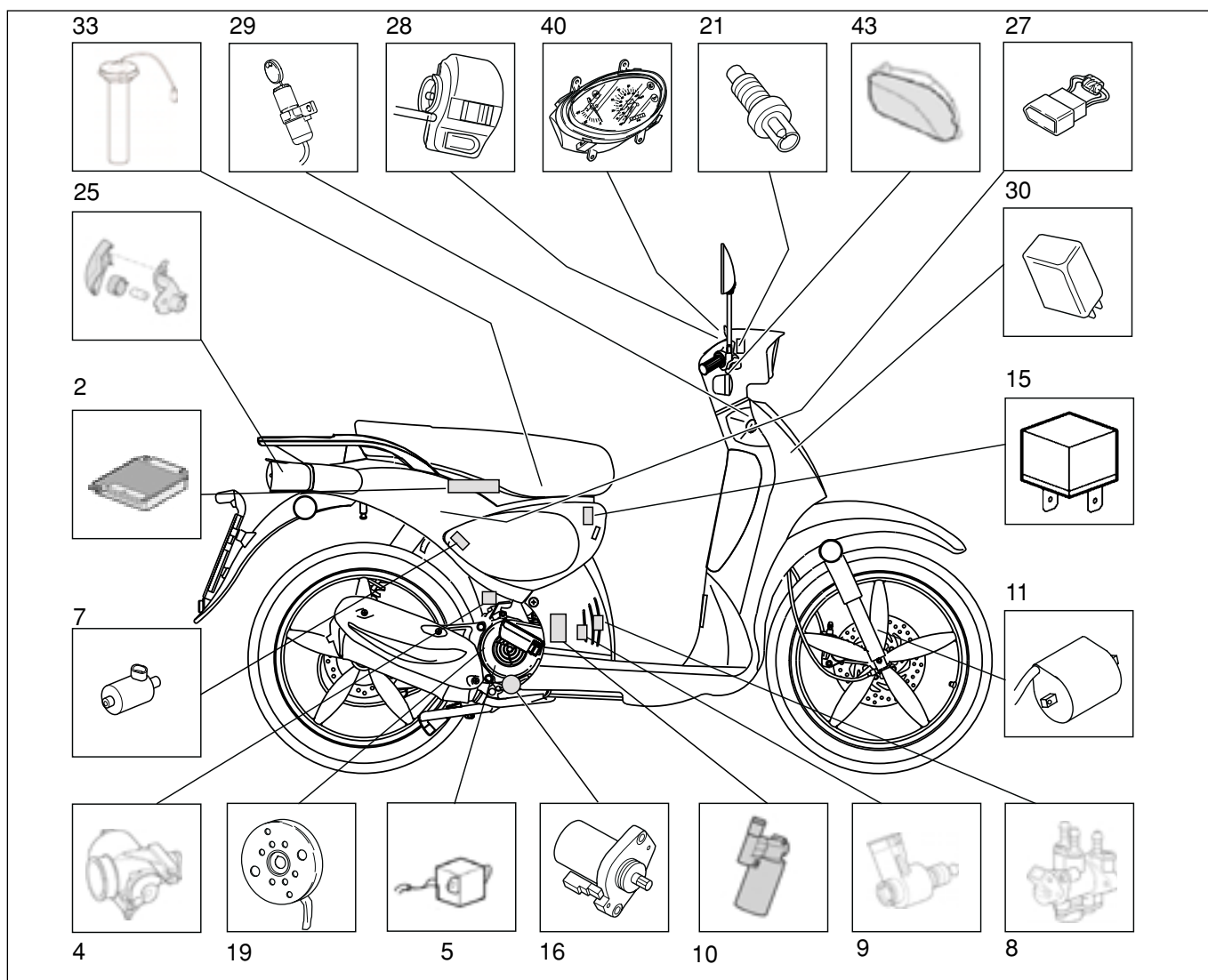

KEY

- 2) C.D.I.
- 4) Throttle sensor
- 5) Pick up
- 7) Oil pump
- 8) Fuel injector
- 9) Air injector
- 10) Fuel pump
- 11) H.T. coil
- 15) Start relay
- 16) Starter motor
- 19) Generator
- 21) Front stoplight switch
- 25) Rear right direction indicator
- 27) Control diode
- 28) Starter switch
- 29) Steering lock
- 30) Flasher
- 33) Fuel level sensor
- 40) Dashboard
- 43) Front right direction indicator

ARRANGEMENT AND FASTENING OF CABLES AND WIRINGS

ARRANGEMENT OF CABLES AND WIRINGS

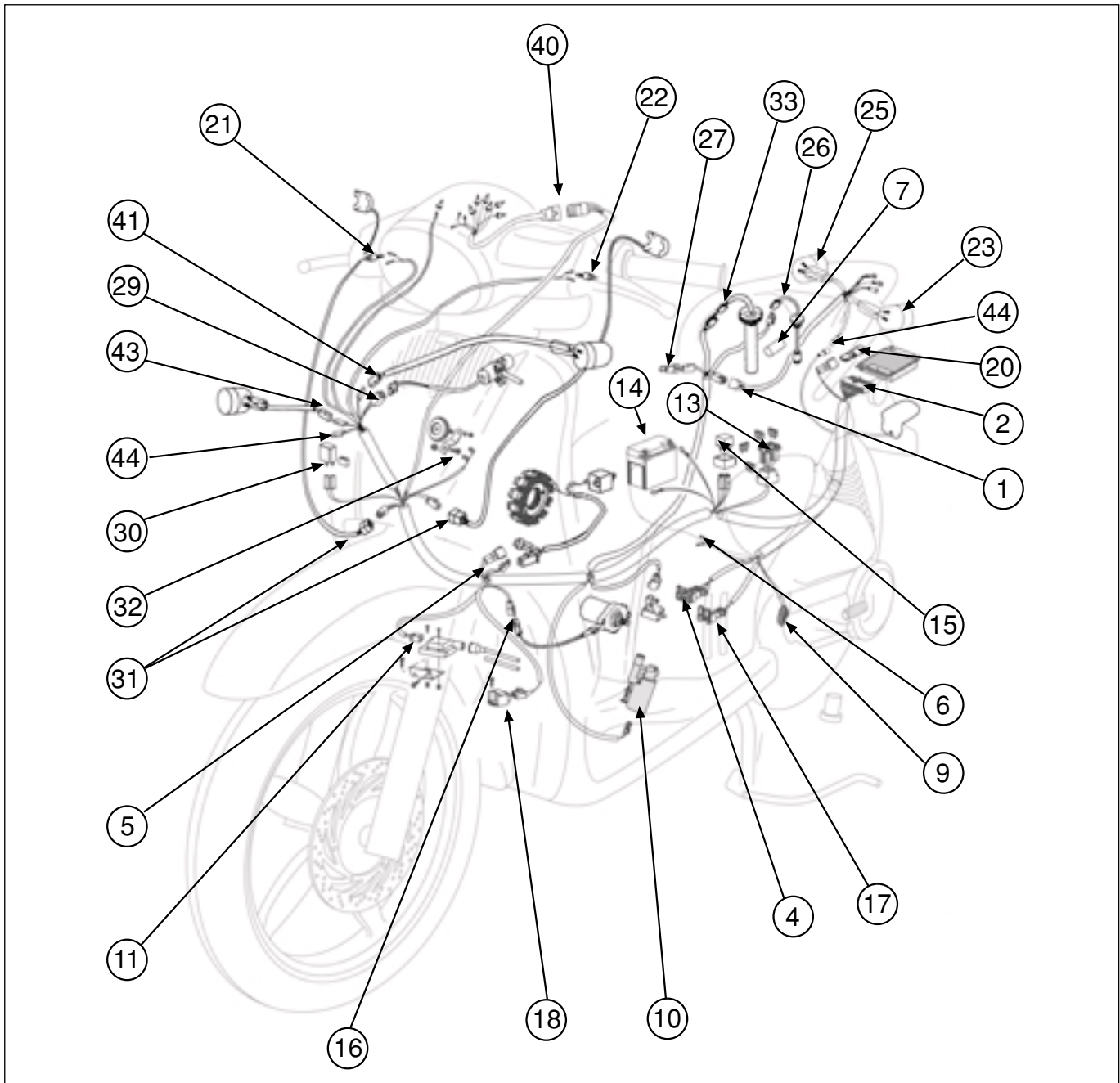

KEY

- 1) Multiple connectors
- 2) C.D.I.
- 4) Throttle sensor
- 5) Pick-up
- 6) Temperature sensor
- 7) Oil pump
- 9) Air injector
- 10) Fuel pump
- 11) HT coil
- 13) Fuses
- 14) Battery
- 15) Start relay
- 16) Starter motor
- 17) Injection relay
- 18) Voltage regulator
- 20) Pressure sensor
- 21) Front stoplight switch
- 22) Rear stoplight switch
- 23) Rear left direction indicator
- 25) Rear right direction indicator
- 26) Oil level switch
- 27) Control diode
- 29) Steering lock
- 30) Flasher
- 31) Left dimmer switch
- 32) Horn
- 33) Fuel level sensor
- 40) Dashboard
- 41) Front left direction indicator
- 43) Front right direction indicator
- 44) License plate light

FASTENING OF CABLES AND WIRINGS

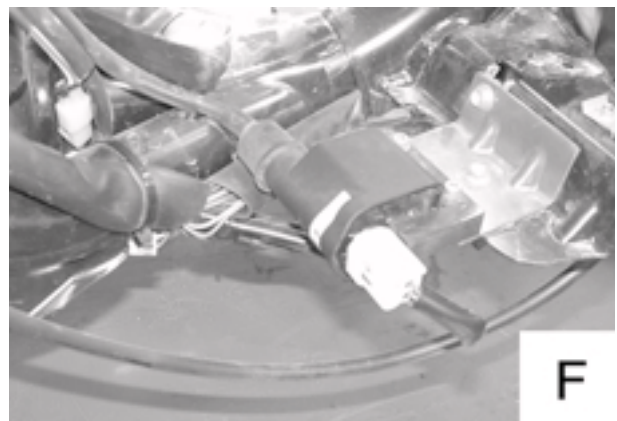
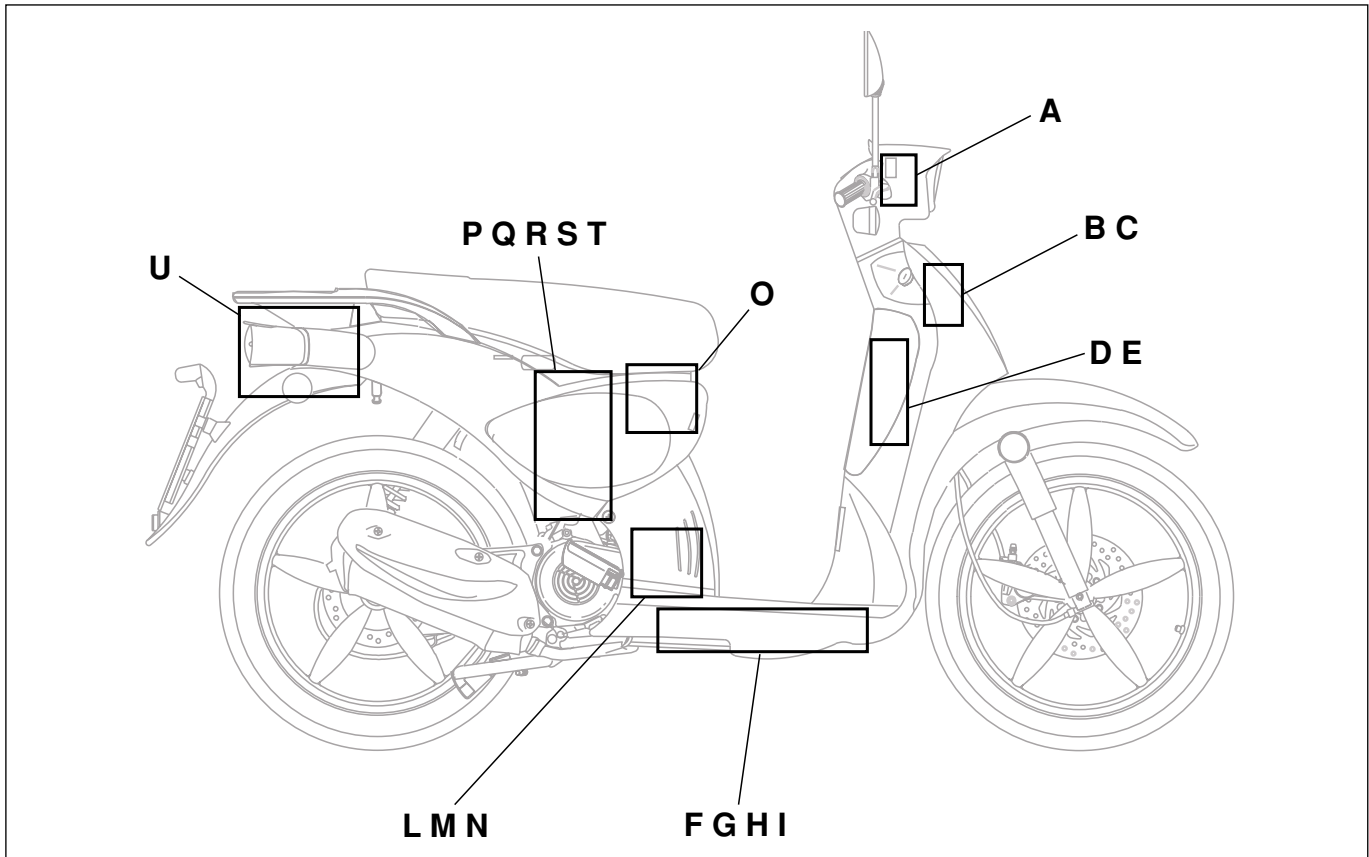

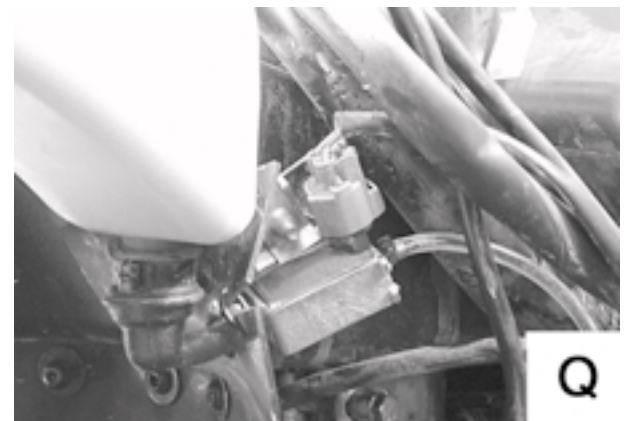
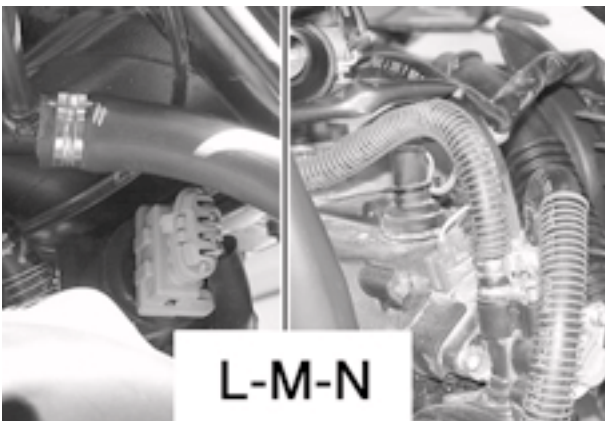



aprilia s.p.a.
via G.Galilei, 1
30033 Noale (VE) Italy
tel. +39 041.5829111
fax +39 041.5829190

www.serviceaprilia.com