

aprilia

SCARABEO 125 - 150 - 200



aprilia part# 8104381

use+maintenancebook

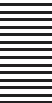

SAFETY WARNINGS

The following precautionary warnings are used throughout this manual in order to convey the following messages:

 **Safety warning. When you find this symbol on the vehicle or in the manual, be careful to the potential risk of personal injury. Non-compliance with the indications given in the messages preceded by this symbol may result in grave risks for your and other people's safety and for the vehicle!**

First edition: september 2001

Reprint:

Produced and printed by:
stp editing division
Soave (VERONA) - Italy
Tel. +39 - 045 76 11 911
Fax +39 - 045 76 12 241
E-mail: customer@stp.it
www.stp.it

On behalf of:
aprilia s.p.a.
via G. Galilei, 1 - 30033 Noale (VE) - Italy
Tel. +39 - 041 58 29 111
Fax +39 - 041 44 10 54
www.aprilia.com

WARNING

Indicates a potential hazard which may result in serious injury or even death.

CAUTION

Indicates a potential hazard which may result in minor personal injury or damage to the vehicle.

NOTE The word “NOTE” in this manual precedes important information or instructions.

TECHNICAL

★ The operations preceded by this symbol must be repeated also on the opposite side of the vehicle.

If not expressly indicated otherwise, for the reassembly of the units repeat the disassembly operations in reverse order.

The terms “right” and “left” are referred to the rider seated on the vehicle in the normal riding position.

WARNINGS - PRECAUTIONS - GENERAL ADVICE

Before starting the engine, carefully read this manual and in particular the section “SAFE DRIVE”.

Your and other people's safety depends not only on your quickness of reflexes and on your agility, but also on what you know about the vehicle, on its efficiency and on your knowledge of the basic information for “SAFE DRIVE”. Therefore, get a thorough knowledge of the vehicle, in such a way as to be able to drive in the traffic safely.

NOTE This manual must be considered as an integral part of the vehicle and must always accompany it, even in case of resale.

aprilia has carried out this manual with the maximum attention, in order to supply the user with correct and updated information. However, since **aprilia** constantly improves the design of its products, there may be slight discrepancies between the characteristics of your vehicle and those described in this manual.

For any clarification concerning the information contained in this manual, do not hesitate to contact your **aprilia** Official Dealer.

For control and repair operations not expressly described in this publication, for the purchase of **aprilia** genuine spare parts, accessories and other products, as well as for specific advice, contact exclusively **aprilia** Official Dealers and Service Centers, which guarantee prompt and accurate assistance.

Thank you for choosing **aprilia**. We wish you a nice ride.

All rights as to electronic storage, reproduction and total or partial adaptation, with any means, are reserved for all Countries.

NOTE In some countries the antipollution and noise regulations in force require periodical inspections.

The user of the vehicle in these countries must:

- contact an **aprilia** Official Dealer to have the non-homologated components replaced with others homologated for use in the country in question;
- carry out the required periodical inspections.

NOTE Soon after purchasing the vehicle, write down the identification data indicated on the SPARE PARTS IDENTIFICATION LABEL in the table here below. The label is stuck to the right upper tube of the frame; to read it, it is necessary to remove the central fairing, see see p. 47 (REMOVING THE CENTRAL FAIRING)

aprilia		YEAR					I.M.							
		Y	1	2	3	4	A	B	C	D	E			
I	UK	A	P	SF	B	D	F	E	GR					
NL	CH	DK	J	SGP	SLO	IL	ROK	MAL	RCH					
HR	AUS	USA	BR	RSA	NZ	CDN								

These data indicate:

- YEAR = year of manufacture (Y, 1, 2, ...);
- I.M. = modification code (A, B, C, ...);
- COUNTRY CODES = homologation country (I, UK, A, ...).

and are to be supplied to the **aprilia** Official Dealer as reference data for the purchase of spare parts or specific accessories of the model you have acquired.

In this manual the various versions are indicated by the following symbols:

- 125** 125 cm³ model
- 150** 150 cm³ model
- 200** 200 cm³ model
- ASD** automatic light switching version (Automatic Switch-on Device)
- OPT** optional

VERSION:

- I** Italy
- UK** United Kingdom
- A** Austria
- P** Portugal
- SF** Finland
- B** Belgium
- D** Germany
- F** France
- E** Spain
- GR** Greece
- NL** Holland
- CH** Switzerland
- DK** Denmark
- J** Japan
- SGP** Singapore
- SLO** Slovenia
- IL** Israel
- ROK** South Korea
- MAL** Malaysia
- RCH** Chile
- HR** Croatia
- AUS** Australia
- USA** United States of America
- BR** Brazil
- RSA** South Africa
- NZ** New Zealand
- CDN** Canada

TABLE OF CONTENTS

SAFE DRIVE	5	RUNNING-IN.....	35	RECHARGING THE BATTERY.....	54
BASIC SAFETY RULES.....	6	STOPPING.....	35	INSTALLING THE BATTERY.....	54
CLOTHING.....	9	PARKING.....	35	CHANGING THE FUSES.....	55
ACCESSORIES.....	10	POSITIONING THE VEHICLE		CHECKING THE SWITCHES.....	56
LOAD.....	10	ON THE STAND.....	36	VERTICAL ADJUSTING OF THE	
ARRANGEMENT OF THE MAIN ELEMENTS	12	SUGGESTIONS TO PREVENT THEFT.....	37	HEADLIGHT BEAM.....	56
ARRANGEMENT		MAINTENANCE	37	BULBS.....	57
OF THE INSTRUMENTS/CONTROLS	14	REGULAR SERVICE INTERVALS CHART.....	38	CHANGING THE	
INSTRUMENTS AND INDICATORS	14	IDENTIFICATION DATA.....	40	DIRECTION INDICATOR BULBS.....	57
INSTRUMENTS AND INDICATORS TABLE.....	15	CHECKING THE ENGINE OIL LEVEL		CHANGING THE HEADLIGHT BULBS.....	58
MAIN INDEPENDENT CONTROLS	16	AND TOPPING UP.....	41	CHANGING THE REAR LIGHT BULB.....	59
CONTROLS ON THE LEFT SIDE		AIR CLEANER.....	42	NUMBER PLATE BULB.....	59
OF THE HANDLEBAR.....	16	CHECKING THE BRAKE PAD WEAR.....	43	TRANSPORT	60
CONTROLS ON THE RIGHT SIDE		CHECKING THE STAND.....	44	DRAINING THE FUEL TANK.....	60
OF THE HANDLEBAR.....	17	INSPECTING THE FRONT		CLEANING	61
IGNITION SWITCH.....	18	AND REAR SUSPENSIONS.....	44	LONG PERIODS OF INACTIVITY.....	62
STEERING LOCK.....	18	ADJUSTING THE REAR SUSPENSION.....	45	TECHNICAL DATA	63
AUXILIARY EQUIPMENT	19	CHECKING THE STEERING.....	46	WIRING DIAGRAM -	
DIGITAL CLOCK.....	19	CHECKING THE ENGINE FULCRUM AXIS.....	46	Scarabeo 125 -	
BAG HOOK.....	19	REMOVING THE CENTRAL		Scarabeo 150 - Scarabeo 200.....	66
ANTI-THEFT HOOK.....	20	INSPECTION COVER.....	47	WIRING DIAGRAM KEY -	
UNLOCKING / LOCKING THE SADDLE.....	20	REMOVING THE CENTRAL FAIRING.....	47	Scarabeo 125 -	
CRASH HELMET CASE.....	20	REMOVING THE REAR-VIEW MIRRORS.....	48	Scarabeo 150 - Scarabeo 200.....	67
GLOVE COMPARTMENT.....	21	REMOVING THE FRONT COVER.....	48	LUBRICANT CHART.....	68
ADJUSTABLE PASSENGER SEAT.....	21	REMOVING		Importers.....	70-71
TOOL KIT.....	21	THE FRONT INSPECTION COVER.....	49		
MAIN COMPONENTS	22	REMOVING THE CRASH HELMET CASE.....	49		
FUEL.....	22	REMOVING THE			
LUBRICANTS.....	23	FRONT PART OF THE FAIRING.....	49		
BRAKE FLUID-recommendations.....	24	IDLING ADJUSTMENT.....	50		
DISC BRAKES.....	24	ADJUSTING			
COOLANT.....	26	THE ACCELERATOR CONTROL.....	50		
TYRES.....	28	SPARK PLUG.....	51		
AUTOMATIC		BATTERY.....	52		
LIGHT SWITCHING VERSION ASD	29	LONG INACTIVITY OF THE BATTERY.....	52		
EXHAUST SILENCER.....	29	EXTRACTING THE BATTERY CASE.....	53		
INSTRUCTIONS FOR USE	30	CHECKING AND CLEANING			
PRELIMINARY CHECKING OPERATIONS.....	30	THE TERMINALS.....	53		
STARTING.....	31	REMOVING THE BATTERY.....	53		
DEPARTURE AND DRIVE.....	33	CHECKING			
		THE ELECTROLYTE LEVEL.....	54		

aprilia



safe drive

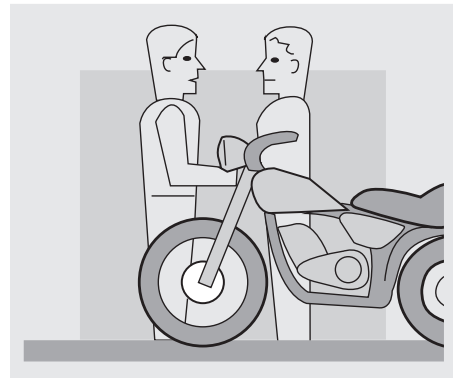
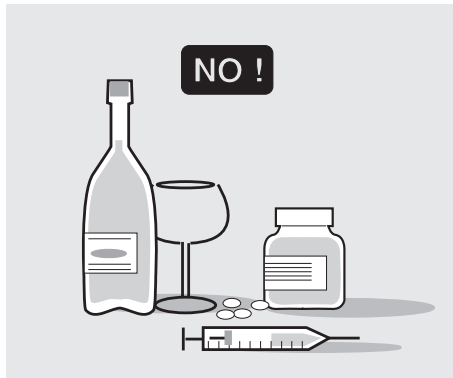

BASIC SAFETY RULES

To drive the vehicle it is necessary to be in possession of all the requirements prescribed by law (driving licence, minimum age, psychophysical ability, insurance, state taxes, vehicle registration, number plate, etc.).

Gradually get to know the vehicle by driving it first in areas with low traffic and/or private areas.

The use of medicines, alcohol and drugs or psychotropic substances notably increases the risk of accidents.

Be sure that you are in good psychophysical conditions and fit for driving and pay particular attention to physical weariness and drowsiness.

Most road accidents are caused by the driver's lack of experience.

NEVER lend the vehicle to beginners and, in any case, make sure that the driver has all the requirements for driving.

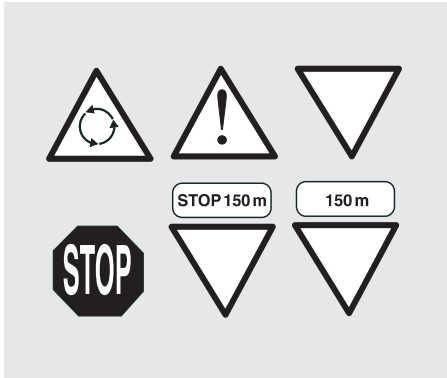

Rigorously observe all road signs and national and local road regulations.

Avoid abrupt movements that can be dangerous for yourself and other people (for example: rearing up on the back wheel, speeding, etc.), and give due consideration to the road surface, visibility and other driving conditions.

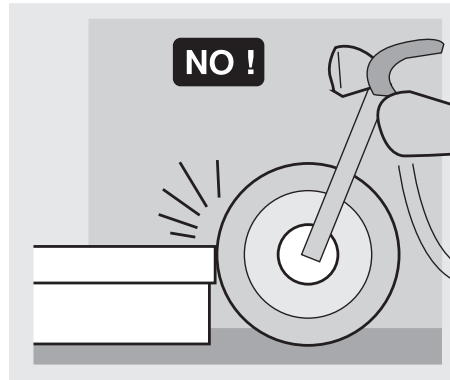

Avoid obstacles that could damage the vehicle or make you lose control.

Avoid riding in the slipstream created by preceding vehicles in order to increase your speed.

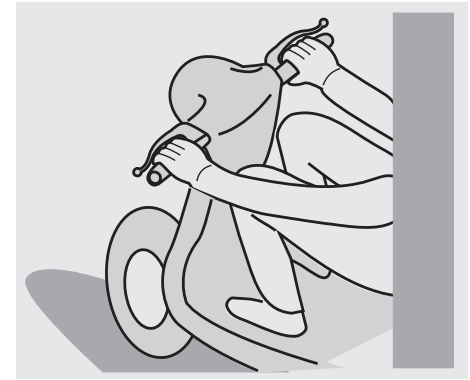

Always keep both hands on the handlebars and both feet on the footboard (or on the footrests), in the correct driving posture.

Avoid standing up or stretching your limbs while driving.

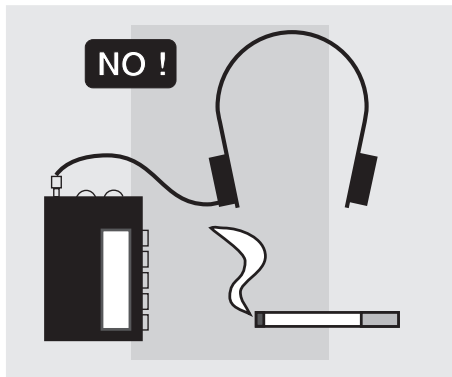

The driver should pay attention and avoid distractions caused by people, things and movements (never smoke, eat, drink, read, etc.) while driving.

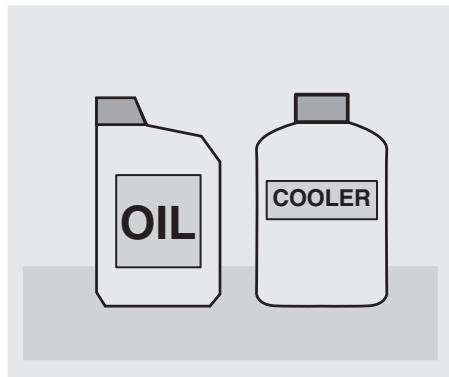

Use only the vehicle's specific fuels and lubricants indicated in the "LUBRICANT CHART"; check all oil, fuel and coolant levels regularly.

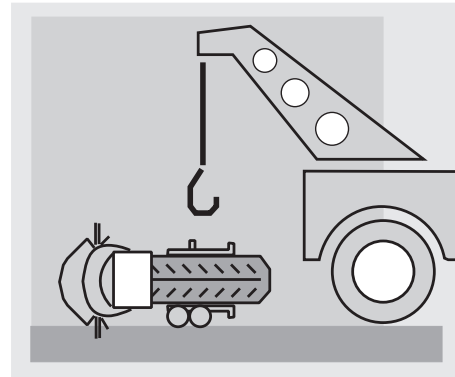

If the vehicle has been involved in an accident, make sure that no damage has occurred to the control levers, pipes, wires, braking system and vital parts.

If necessary, have the vehicle inspected by an **aprilia** Official Dealer, who should carefully check the frame, handlebars, suspensions, safety parts and all the devices that you cannot check by yourself.

Always remember to report any malfunction to the technicians to help them in their work.

Never use the vehicle when the amount of damage it has suffered endangers your safety.

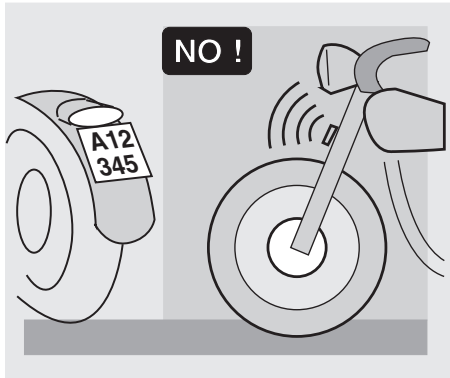

Never change the position, inclination or colour of: number plate, direction indicators, lights and horns.

Any modification of the vehicle will result in the invalidity of the guarantee.

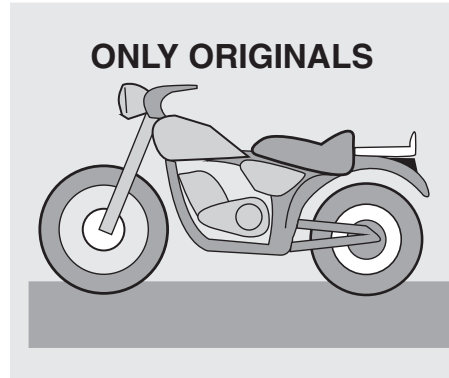

Any modification of the vehicle and/or the removal of original components can compromise vehicle performance levels and safety or even make it illegal.

We recommend respecting all regulations and national and local provisions regarding the equipment of the vehicle.

In particular, avoid all modifications that increase the vehicle's performance levels or alter its original characteristics.

Never race with other vehicles.

Avoid off-road driving.

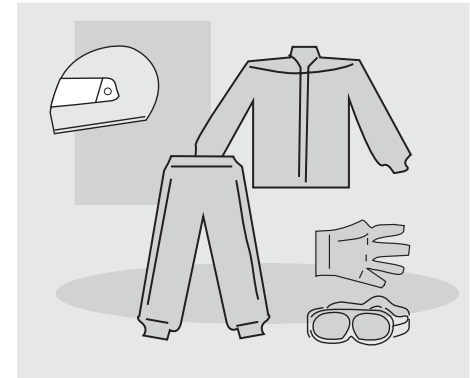

CLOTHING

Before starting, always wear a correctly fastened crash helmet. Make sure that it is homologated, in good shape, of the right size and that the visor is clean.

Wear protective clothing, preferably in light and/or reflecting colours.

In this way you will make yourself more visible to the other drivers, thus notably reducing the risk of being knocked down, and you will be more protected in case of fall.

This clothing should be very tight-fitting and fastened at the wrists and ankles.

Strings, belts and ties should not be hanging loose; prevent these and other objects from interfering with driving by getting entangled with moving parts or driving mechanisms.

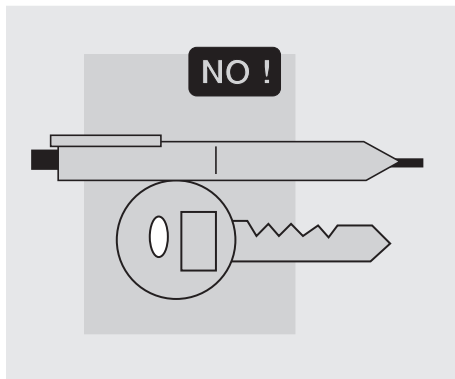

Do not keep objects that can be dangerous in case of fall, for example pointed objects like keys, pens, glass vials etc. in your pockets (the same recommendations also apply to passengers).

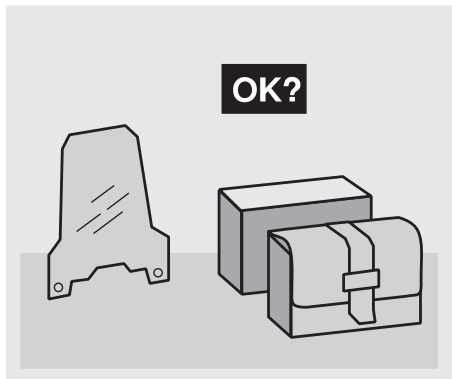

ACCESSORIES

The owner of the vehicle is responsible for the choice, installation and use of any accessory.

Avoid installing accessories that cover horns or lights or that could impair their functions, limit the suspension stroke and the steering angle, hamper the operation of the controls and reduce the distance from the ground and the angle of inclination in turns.

Avoid using accessories that hamper access to the controls, since this can prolong reaction times during an emergency.

Big fairings and windshields installed on the vehicle may produce aerodynamic forces that affect the stability of the vehicle, especially when riding at high speed.

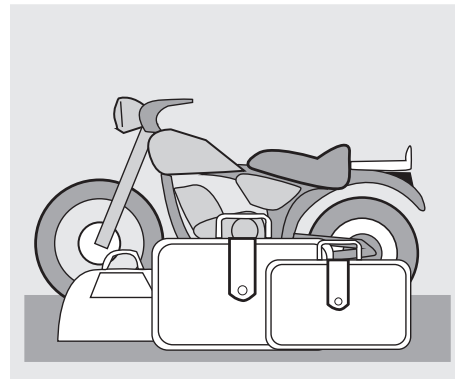

Make sure that the equipment is well fastened to the vehicle and not dangerous during driving. Do not install electrical devices and do not modify those already existing to avoid electrical overloads, because the vehicle could suddenly stop or there could be a dangerous current shortage in the horn and in the lights. **aprilia** recommends the use of "**aprilia** genuine accessories".

LOAD

Be careful and moderate when loading your luggage. Keep any luggage loaded as close as possible to the center of gravity of the vehicle and distribute the load uniformly on both sides, in order to reduce imbalance to the minimum. Furthermore, make sure that the load is firmly secured to the vehicle, especially during long trips.

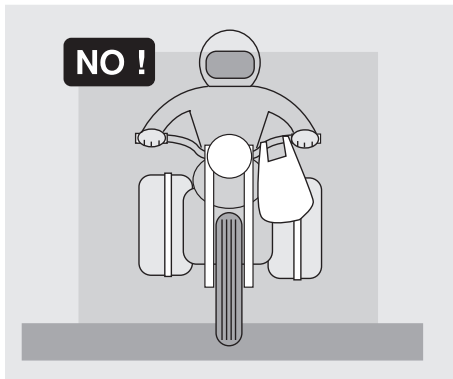

Avoid hanging bulky, heavy and/or dangerous objects on the handlebars, mudguards and forks: the vehicle might respond more slowly in turns and its manoeuvrability could be unavoidably impaired.

Do not place bags that are too bulky on the vehicle sides, because they could hit people or obstacles, making you lose control of the vehicle.

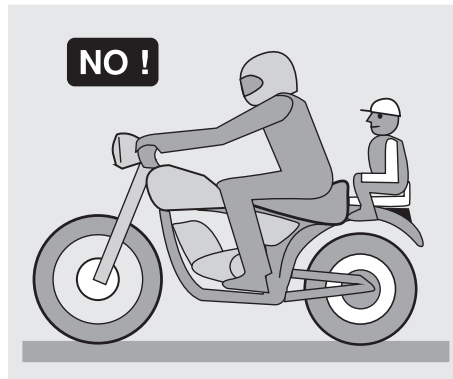

Do not carry any bag if it is not tightly secured to the vehicle.

Do not carry bags which protrude too much from the luggage-rack or which cover the lights, horn or indicators.

Do not carry animals or children on the glove compartment or on the luggage-rack.

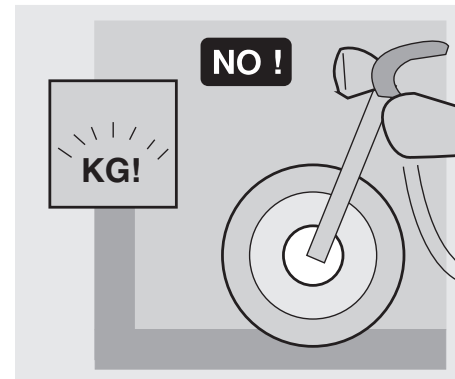

Do not exceed the maximum load allowed for each side-bag.

When the vehicle is overloaded, its stability and its manoeuvrability can be compromised.

ARRANGEMENT OF THE MAIN ELEMENTS

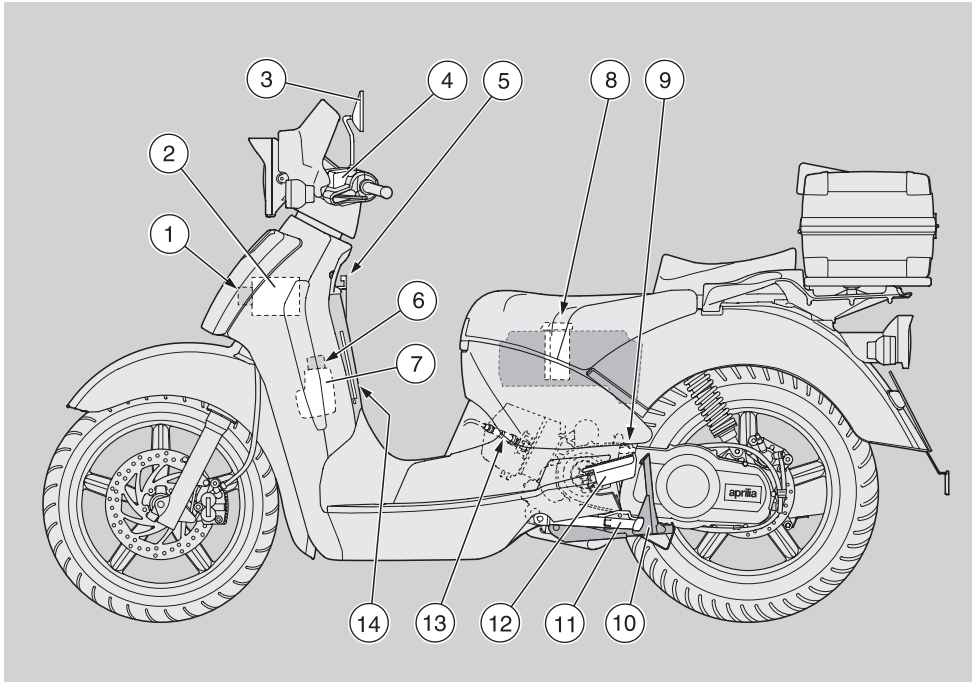

KEY

- | | | |
|--------------------------------|--|-----------------------------|
| 1) Fuse carrier | 7) Expansion tank | 12) Passenger left footrest |
| 2) Battery | 8) Air cleaner | 13) Spark plug |
| 3) Left rear-view mirror | 9) Anti-theft hook (for the aprilia "Body-Guard" armored cable OPT) | 14) Front inspection cover |
| 4) Rear brake reservoir | 10) Centre stand | |
| 5) Bag hook | 11) Side stand OPT (series 200) | |
| 6) Coolant expansion tank plug | | |

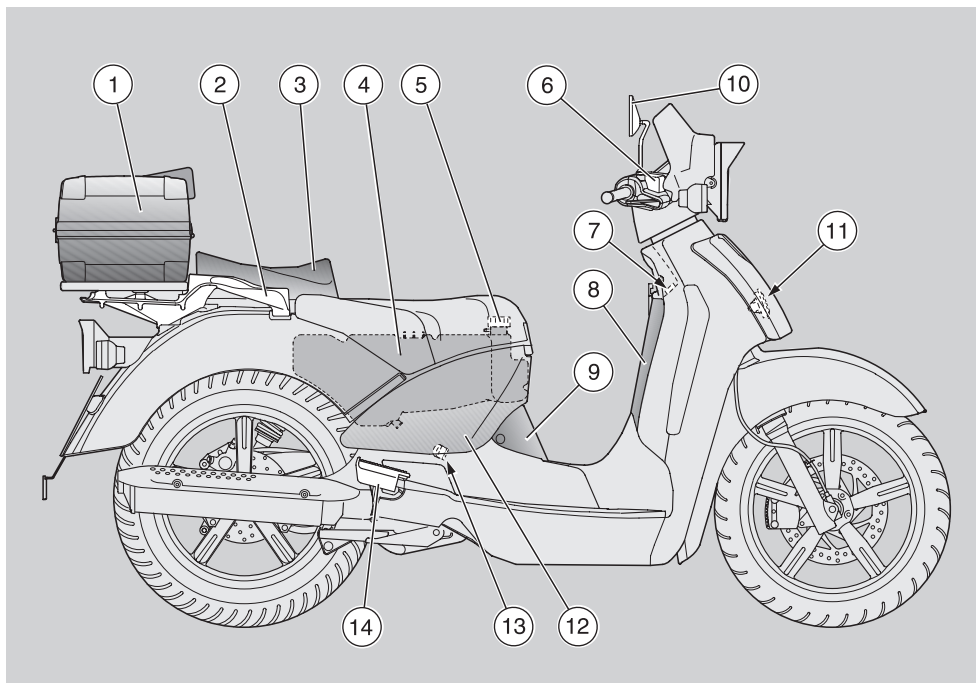

KEY

- 1) Crash helmet case
- 2) Passenger grab rail
- 3) Passenger seat
- 4) Fuel tank
- 5) Filler cap
- 6) Front brake reservoir

- 7) Ignition switch / steering lock / saddle unlocking device
- 8) Glove compartment
- 9) Central inspection cover
- 10) Right rear-view mirror
- 11) Horn

- 12) Central fairing
- 13) Engine oil filling/level cap
- 14) Passenger right footrest

ARRANGEMENT OF THE INSTRUMENTS/CONTROLS

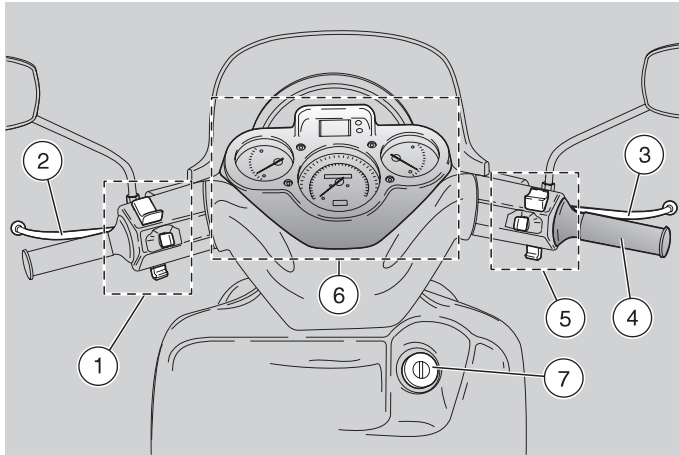

KEY

- 1) Electrical controls on the left side of the handlebar
- 2) Rear brake lever
- 3) Front brake lever
- 4) Throttle grip
- 5) Electrical controls on the right side of the handlebar
- 6) Instruments and indicators
- 7) Ignition switch / steering lock (○ - ☒ - Ⓜ) / saddle unlocking device (OPEN)



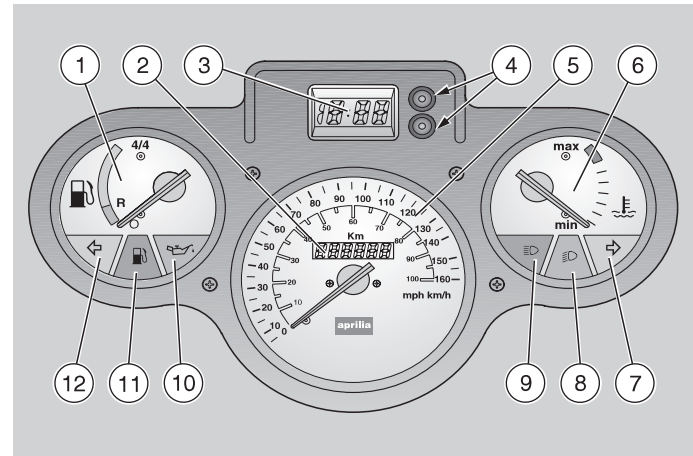





INSTRUMENTS AND INDICATORS



KEY

- 1) Fuel level indicator (⛽)
- 2) Total kilometres odometer
- 3) Digital clock
- 4) Digital clock function and setting push buttons
- 5) Speedometer
- 5) Speedometer – km/h scale only **AUS**
- 6) Coolant temperature indicator (🌡)
- 7) Green right direction indicator warning light (↗)
- 8) Green low beam warning light (🔦)
- 9) Blue high beam warning light (🔦)
- 10) Red engine oil pressure warning light (🛢)
- 11) Amber low fuel warning light (⛽)
- 12) Green left direction indicator warning light (↖)

INSTRUMENTS AND INDICATORS TABLE

Description	Function
Right direction indicator warning light 	It blinks when the right direction indicator is on.
Left direction indicator warning light 	It blinks when the left direction indicator is on.
Engine oil pressure warning light 	<p>It comes on every time the ignition switch is brought to position "O" and the engine is not running, thus testing the correct operation of the bulb. If during this phase the lamp does not turn on, it must be replaced. The warning light must go off when the engine is running.</p> <p>▲ CAUTION If the warning light comes on during the normal running of the engine, this means that the oil pressure in the circuit is insufficient. In this case, immediately stop the engine and contact your aprilia Official Dealer.</p>
Total kilometres odometer	It indicates the total number of kilometres covered.
Speedometer	It indicates the driving speed.
High beam warning light 	It comes on when the headlight is in "high beam" position or when the high beam signaller is operated (PASSING ).
Low beam warning light 	It comes on when the headlight is in low beam position.
Low fuel warning light 	It comes on when the quantity of fuel left in the tank is about 2 ℓ.
Fuel level indicator 	<p>It indicates the approximate fuel level in the tank. When the pointer reaches the red area, the quantity of fuel left in the tank is about 2 ℓ.</p> <p>In this case, top up as soon as possible, see p. 22 (FUEL).</p>
Digital clock	Hour, date and seconds can be shown on the display, see p. 19 (DIGITAL CLOCK).
Coolant temperature indicator 	<p>It indicates the approximate temperature of the coolant in the engine. When the pointer starts moving beyond level "min", the temperature is sufficient for driving the vehicle. The normal running temperature range is indicated by the central area of the scale. If the pointer reaches the red area, stop the engine and check the coolant level, see p. 26 (COOLANT).</p> <p>▲ CAUTION If the maximum allowed temperature is exceeded (red area "max" of the scale), the engine may be seriously damaged.</p>

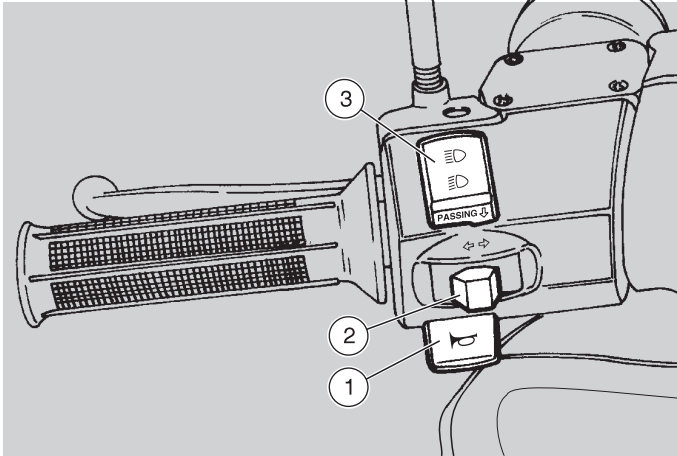

CONTROLS ON THE LEFT SIDE OF THE HANDLEBAR

NOTE The electrical parts work only when the ignition switch is in position "O".

1) HORN PUSH BUTTON (📣)

The horn is activated when the "📣" push button is pressed.

2) DIRECTION INDICATOR SWITCH (↔)

To indicate the turn to the left, move the switch to the left; to indicate the turn to the right, move the switch to the right.

To turn off the direction indicator, press the switch on its centre.

3) DIMMER SWITCH (📡 - 📡) / HIGH BEAM SIGNALLER PUSH BUTTON (PASSING ↓)

When the light switch is in position "📡": if the dimmer switch is in position "📡", the high beam comes on, while if it is in position "📡", the low beam comes on.

The high beam signaller is operated by pressing the dimmer switch to position (PASSING ↓), independently of the position of the light switch (📡 - 📡 - •).

NOTE When the dimmer switch is released, the high beam signaller is disconnected.

CONTROLS ON THE RIGHT SIDE OF THE HANDLEBAR

NOTE The electrical parts work only when the ignition switch is in position "○".

1) LIGHT SWITCH (☀ - ☂☑ - ●) (ASD not provided)

⚠ CAUTION

Before operating the light switch, make sure that the dimmer switch (☹ - ☹☹) is in position "☹☹".

When the light switch is in position "●", the lights are off; when the switch is in position "☂☑", the parking lights and the dashboard light are on; when the switch is in position "☀", the parking lights, the dashboard light and the low beam are on. The high beam can be operated by means of the dimmer switch (☹☹ - ☹☹☹).

2) START PUSH BUTTON (⊕)

When the start push button "⊕" is pressed, the starter makes the engine run. For the starting, see p. 31 (STARTING).

3) ENGINE STOP SWITCH (○ - ☒)

⚠ WARNING

Do not operate the engine stop switch "○ - ☒" in running conditions.

This is a safety or emergency switch. With the switch in position "○", it is possible to start the engine; the engine can be stopped by moving the switch to position "☒".

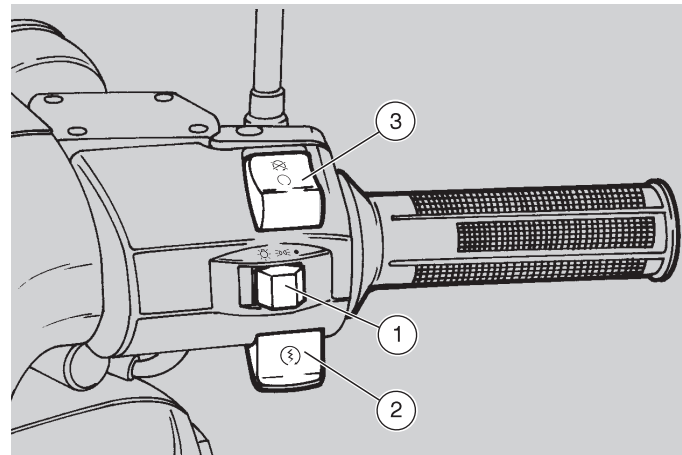

⚠ CAUTION

With stopped engine and ignition switch in position "○", the battery may run down.

When the vehicle has come to a halt, stop the engine, and move the ignition switch to position "☒".

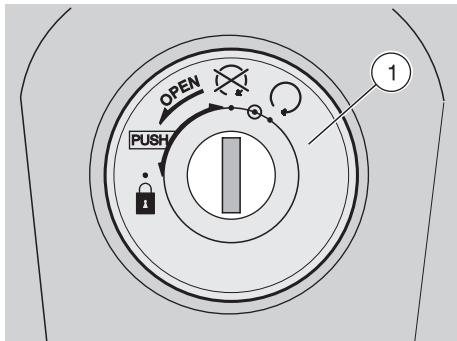

IGNITION SWITCH

The ignition switch (1) is positioned on the right side, near the steering column.

NOTE The key (2) operates the ignition switch / steering lock, the saddle lock and the glove compartment lock.

Two keys are supplied together with the vehicle (one spare key).

NOTE Do not keep the spare key on the vehicle.

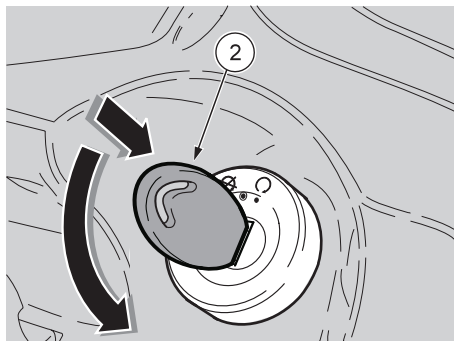

STEERING LOCK

⚠ WARNING

Never turn the key to position "🔒" in running conditions, in order to avoid losing control of the vehicle.

OPERATION

To lock the steering:



- ◆ Turn the handlebar completely leftwards.
- ◆ Turn the key (2) to position "🔒".

⚠ WARNING

The simple turning of the key, without any pressure, operates the saddle lock and not the steering lock.

NOTE Turn the key and steer the handlebar at the same time.

- ◆ Press the key (2) and turn it anticlockwise (to the left), then steer the handlebar slowly, until the key (2) reaches position "🔒".
- ◆ Extract the key.

Position	Function	Key removal
 Steering lock	The steering is locked. It is neither possible to start the engine, nor to switch on the lights.	It is possible to remove the key.
	Neither the engine, nor the lights can be switched on.	It is possible to remove the key.
	The engine and the lights can be switched on.	It is not possible to remove the key.

AUXILIARY EQUIPMENT

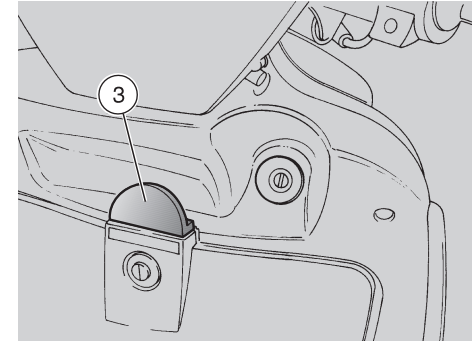
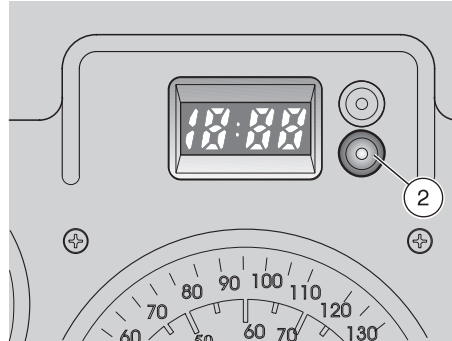
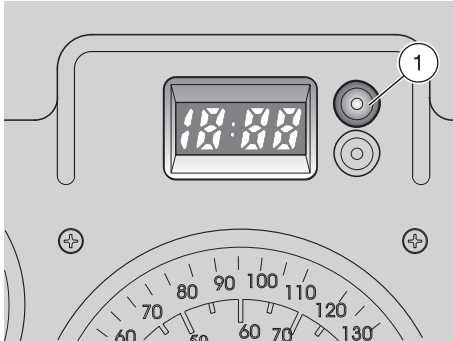

DIGITAL CLOCK

Function description:

- ◆ Normal display: hours and minutes.
- ◆ Date display: press the push button (1) once to display month and day.
- ◆ Second display: press the push button (1) twice to display the seconds.

NOTE To replace the clock battery, contact an **aprilia** Official Dealer.

Setting:

- ◆ Press the push button (2) once: date and time will be displayed alternately.
- ◆ Month: press the push button (2) again and the month will be displayed on the left (the rest disappears). Press the push button (1) to set the desired month.
- ◆ Day: press the push button (2) again and the day will be displayed on the right. Press the push button (1) to set the desired day.
- ◆ Time: press the push button (2) again and the time will be displayed on the left with letter "A" or "P" (A = AM, P = PM).
- ◆ Minutes: press the push button (2) again and the minutes will be displayed on the right. Press the push button (1) to set the desired minutes.

Now the clock is set.

Press the push button (2) and then the push button (1), again to return to normal functioning.

BAG HOOK

▲ WARNING

Do not hang excessively bulky bags or parcels to the hook, as this may seriously compromise the manoeuvrability of the vehicle or the movement of your feet.

The bag hook (3) is positioned on the front part of the inner shield

Max. allowed weight: 1,5 kg

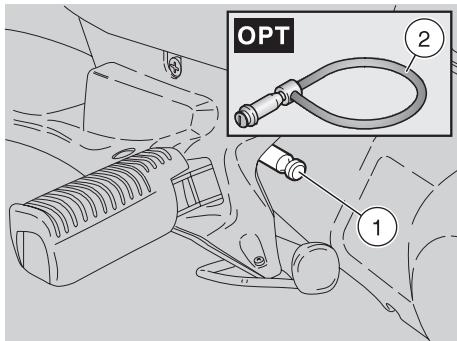

ANTI-THEFT HOOK

The anti-theft hook (1) is positioned on the left side of the vehicle, near the passenger footrest.

To prevent the vehicle from being stolen, it is advisable to secure it with the **aprilia** “Body-Guard” armored cable **OPT** (2), available at any **aprilia** Official Dealer.

⚠ CAUTION

Do not use the hook to lift the vehicle or for any purpose other than securing the vehicle once it has been parked.

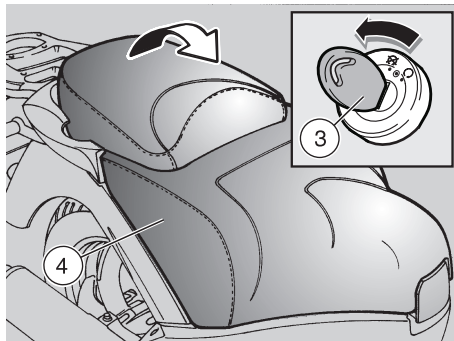

UNLOCKING / LOCKING THE SADDLE

OPERATION

To unlock the saddle, proceed as follows:

- ◆ Position the vehicle on the centre stand.
- ◆ Insert the key in the ignition switch / steering lock.

NOTE Turn the key (3) without pressing it.

- ◆ Turn the key (3) anticlockwise until you hear the snap that indicates that the lock is open.
- ◆ Turn the key back to position “⊗”.
- ◆ Raise the saddle (4).
- ◆ To lock the saddle, lower and press it (without exerting too much pressure), thus making the lock snap shut.

⚠ WARNING

Before leaving, make sure that the saddle is properly locked.

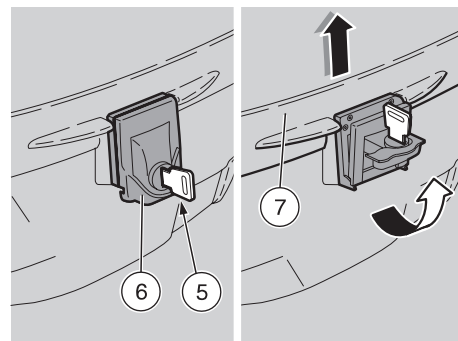

CRASH HELMET CASE

Thanks to the crash helmet case, you needn't carry the helmet or other encumbering objects with you every time you park the vehicle. To reach the crash helmet case, proceed as follows:

- ◆ Insert the key (5) in the lock.
- ◆ Turn the key (5) anticlockwise.
- ◆ Raise the lock unit (6).
- ◆ Raise and open the cover (7).

NOTE The case can contain one crash helmet:

Two keys are supplied together with the vehicle (one spare key).

NOTE Do not keep the spare key on the vehicle.

⚠ WARNING

Do not overload the crash helmet case. Maximum allowed weight: 3 kg

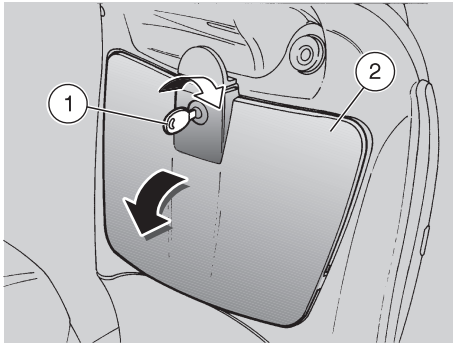

GLOVE COMPARTMENT

It is placed under the handlebar, on the inner part of the shield.

To reach it:

- ◆ Introduce the ignition key (1) in the lock.
- ◆ Turn the key clockwise, pull it and open the door (2).

⚠ CAUTION

Before locking the door, make sure that you have not left the key in the glove compartment.

To lock the door (6), raise and press it. It is not necessary to use the key.

Maximum allowed weight: 1.5 kg.

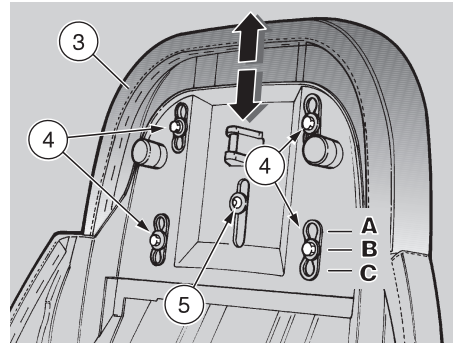

ADJUSTABLE PASSENGER SEAT

The passenger seat (3) can be adjusted longitudinally in three different positions:

- completely forward (A);
- standard (B);
- completely backward (C).

For the adjustment, proceed as follows:

- ◆ Raise the saddle, see p. 20 (UNLOCKING / LOCKING THE SADDLE).

⚠ CAUTION

Do not adjust the special screw (5) for any reason whatsoever. Tampering with this screw is extremely dangerous.

- ◆ Loosen the screws (4).
- ◆ Move the seat (3) to the desired position.
- ◆ Tighten the screws (4).

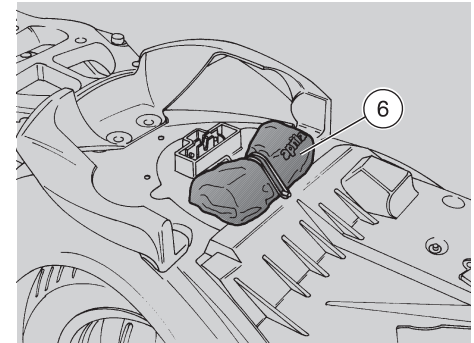

TOOL KIT

The tool kit (6) is fixed in the appropriate compartment under the saddle;

to reach it, proceed as follows:

- ◆ Raise the saddle, see p. 20 (UNLOCKING / LOCKING THE SADDLE).

The tool kit includes:

- 4 mm hexagon spanner;
- 16 mm spark plug socket spanner;
- socket spanner rod;
- 8/10 mm socket spanner;
- double-ended, cross-/cut-headed screwdriver;
- square pin spanner;
- tool case.

MAIN COMPONENTS

FUEL

WARNING

The fuel used for internal combustion engines is extremely inflammable and in particular conditions it can become explosive. It is important to carry out the refuelling and the maintenance operations in a well-ventilated area, with the engine off. Do not smoke while refuelling or near fuel vapours, in any case avoid any contact with naked flames, sparks and any other heat source to prevent the fuel from catching fire or from exploding. Further, prevent fuel from flowing out of the fuel filler, as it could catch fire when getting in contact with the red-hot surfaces of the engine. In case some fuel has accidentally been spilt, make sure that the area is completely dry before starting the vehicle. Since petrol expands under the heat of the sun and due to the effects of sun radiation, never fill the tank to the brim. Screw the cap carefully after refuelling. Avoid any contact of the fuel with the skin and the inhalation of vapours; do not swallow fuel or pour it from a receptacle into another by means of a tube.



DO NOT DISPOSE OF FUEL IN THE ENVIRONMENT.

KEEP AWAY FROM CHILDREN.

Use only leaded (4 Stars ) or unleaded premium grade petrol, min. O.N. 95 (N.O.R.M.) and 85 (N.O.M.M.).

FUEL TANK CAPACITY
(reserve included): 9 ℓ

TANK RESERVE: 2 ℓ

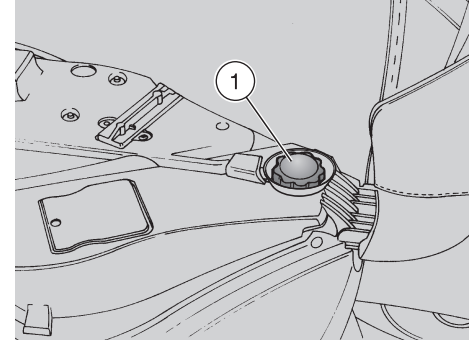

To reach the filler cap, proceed as follows:

- ◆ Raise the saddle, see p. 20 (UNLOCKING / LOCKING THE SADDLE).
- ◆ Unscrew the filler cap (1).



LUBRICANTS

WARNING

Oil can cause serious damage to the skin if handled every day and for long periods. Wash your hands carefully after using oil.

In case any maintenance operation has to be carried out, it is advisable to use latex gloves.

KEEP AWAY FROM CHILDREN.

DO NOT DISPOSE OF OIL IN THE ENVIRONMENT.

CAUTION

Proceed with care.

Do not spill the oil!

Take care not to smear any component, the area in which you are working and the surrounding area. Carefully remove any trace of oil.

In case of leakages or malfunctions, contact an **aprilia** Official Dealer.



TRANSMISSION OIL

Have the transmission oil level checked every 6000 km (3750 mi).

It is necessary to have the transmission oil changed after the first 1000 km (625 mi) and successively every 12000 km (7500 mi).

To check the oil level and to change the oil, contact an **aprilia** Official Dealer.

ENGINE OIL

Check the engine oil level every 1000 km (625 mi), see p. 41 (CHECKING THE ENGINE OIL LEVEL AND TOPPING UP).

It is necessary to have the engine oil changed after the first 1000 km (625 mi) and successively 12000 km (7500 mi).

For the oil change, contact an **aprilia** Official Dealer.

NOTE Use high-quality oils, see p. 68 (LUBRICANT CHART).

The use of oils with SAE classification 15W, 20W or 30W (and in any case with density exceeding that of the recommended oil) could make it difficult to start the vehicle if the ambient temperature is below -5°C .

CAUTION

When topping up the engine oil, never exceed the "MAX" level.

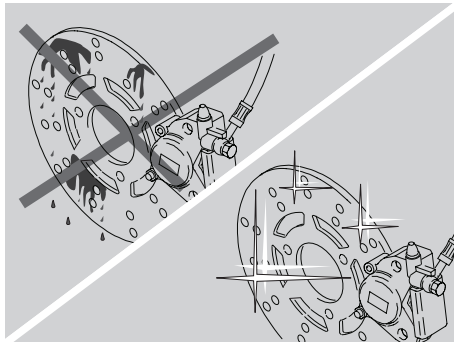

BRAKE FLUID-recommendations

NOTE This vehicle is provided with front and rear disc brakes, with separate hydraulic circuits.

The following information refers to a single braking system, but is valid for both.

⚠ WARNING

Sudden resistance or clearance problems on the brake lever may be due to troubles in the hydraulic system.

For any doubt regarding the perfect functioning of the braking system and in case you are not able to carry out the usual checking operations, contact your **aprilia** Official Dealer.

⚠ WARNING

Pay special attention to the brake disc and friction material, making sure that they are neither dirty nor oily, especially after maintenance operations or inspections.

Make sure that the brake pipe is neither twisted nor worn out.

KEEP AWAY FROM CHILDREN.

DO NOT DISPOSE OF THE FLUID IN THE ENVIRONMENT.

DISC BRAKES

⚠ WARNING

The brakes are the parts that most ensure your safety and for this reason they must always be perfectly working; check them before every trip.

A dirty disc soils the pads, with consequent reduction of the braking efficiency. Dirty pads must be replaced, while dirty discs must be cleaned with a high-quality degreaser.

The brake fluid must be changed every two years by an **aprilia** Official Dealer.



NOTE This vehicle is provided with front and rear disc brakes, with separate hydraulic circuits.

The following information refers to a single braking system, but is valid for both.

When the disc pads wear out, the brake fluid level in the reservoir decreases to automatically compensate for their wear.

The brake reservoirs are positioned on the handlebar, near the brake lever couplings.

Periodically check the brake fluid level in the reservoirs, see beside (CHECKING) and the wear of the pads, see p. 43 (CHECKING THE BRAKE PAD WEAR).

⚠ WARNING

Do not use the vehicle if the braking system leaks fluid.

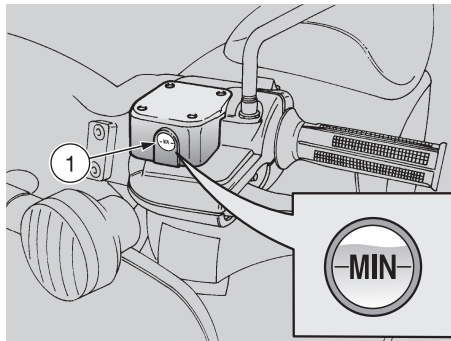

CHECKING

To check the brake fluid level, proceed as follows:

NOTE Position the vehicle on firm and flat ground.

- ◆ Position the vehicle on the centre stand.
- ◆ Rotate the handlebar, so that the fluid contained in the brake reservoir is parallel to the "MIN" mark stamped on the glass gauge (1).
- ◆ Make sure that the fluid contained in the reservoir exceeds the "MIN" mark stamped on the glass gauge (1).

MIN = minimum level.

If the fluid does not reach at least the "MIN" mark:

⚠ CAUTION

When the disc pads wear out, the level of the fluid decreases progressively to compensate for their wear.

- ◆ Check the brake pad wear, see p. 43 (CHECKING THE BRAKE PAD WEAR) and the disc wear.

If the pads and/or the disc do not need replacing:

- ◆ Contact an **aprilia** Official Dealer, who will provide for topping up.

⚠ CAUTION

Check the braking efficiency.

In case of excessive stroke of the brake lever or reduced efficiency of the braking system, contact an **aprilia Official Dealer, since it may be necessary to bleed the system.**

COOLANT

⚠ CAUTION

Do not use the vehicle if the coolant is below the minimum prescribed level "MIN".

Check the coolant level every 2000 km (1250 mi) and after long trips; have the coolant changed by an **aprilia** Official Dealer every 2 years.

⚠ WARNING

The coolant is noxious: do not swallow it; if the coolant gets in contact with the skin or the eyes, it can cause serious irritations.

If the coolant gets in contact with your skin or eyes, rinse with plenty of water and consult a doctor. If it is swallowed, induce vomit, rinse mouth and throat with plenty of water and consult a doctor without delay.

DO NOT DISPOSE OF THE FLUID IN THE ENVIRONMENT.

KEEP AWAY FROM CHILDREN.

Be careful not to spill the coolant on the red-hot parts of the engine: it may catch fire and send out invisible flames.

In case maintenance operations are to be performed, it is advisable to use latex gloves.

Have the coolant changed by an **aprilia Official Dealer.**



The coolant is made up of 50% water and 50% antifreeze.

This mixture is ideal for most running temperatures and ensures good protection against corrosion.

It is advisable to keep the same mixture also in the hot season, since in this way losses due to evaporation are reduced and it is not necessary to top up very frequently.

The mineral salt deposits left in the radiator by evaporated water are thus reduced and the efficiency of the cooling system remains unchanged.

If the outdoor temperature is below 0°, check the cooling circuit frequently and if necessary increase the antifreeze concentration (up to maximum 60%).

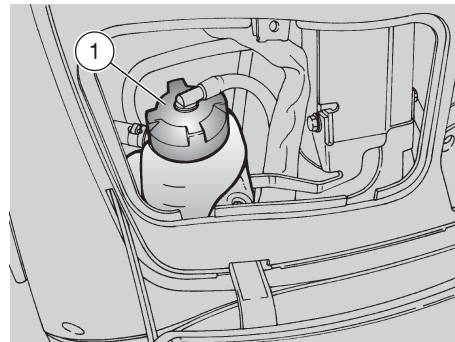

For the cooling solution use distilled water, in order not to damage the engine.

⚠ WARNING

Do not remove the expansion tank plug (1) when the engine is hot, since the coolant is under pressure and its temperature is high. If it gets in contact with the skin or with clothes it may cause severe burns and/or damage.

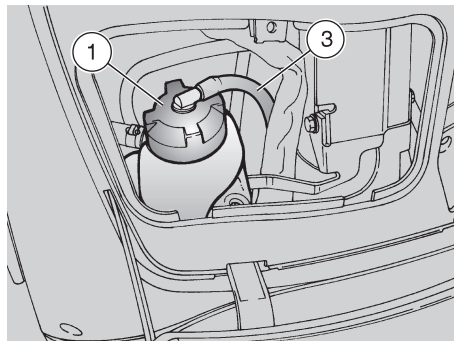
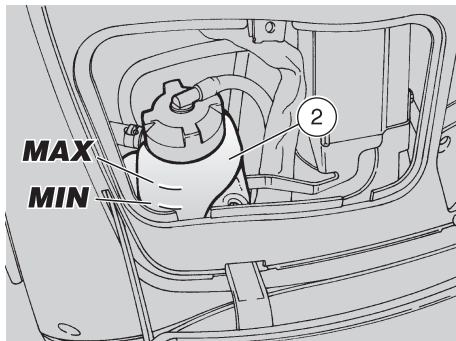

CHECKING AND TOPPING UP

WARNING

Check the coolant level and top up the expansion tank with cold engine.

- ◆ Stop the engine and wait until it has cooled down.

NOTE Position the vehicle on firm and flat ground.

- ◆ Remove the front inspection cover, see p. 49 (REMOVING THE FRONT INSPECTION COVER).
- ◆ Make sure that the level of the fluid contained in the expansion tank (2) is included between the "MIN" and "MAX" marks.

MIN = minimum level.

MAX = maximum level.

If not, proceed as follows:

- ◆ Loosen the filling cap (1) (by giving it two anticlockwise turns), without removing it.
- ◆ Wait a few seconds in order to release any residual pressure.

NOTE A breather pipe (3) is connected to the cap (1). Neither force, nor disconnect the breather pipe (3).

- ◆ Unscrew and remove the cap (1).

WARNING

The coolant is noxious: do not swallow it; if the coolant gets in contact with the skin or the eyes, it can cause serious irritations.

Do not use your fingers or any other object to check if there is enough coolant.

CAUTION

While topping up, never exceed the "MAX" level, otherwise the fluid will flow out of the tank while the engine is running.

- ◆ Top up with coolant, see p. 68 (LUBRICANT CHART) until reaching approx. the "MAX" notch
- ◆ Put back the filling cap (1).

CAUTION

In case of excessive consumption of coolant and in case the tank remains empty, make sure that there are no leaks in the circuit.

Have it repaired by an aprilia Official Dealer.

- ◆ Put back the front inspection cover, see see p. 49 (REMOVING THE FRONT INSPECTION COVER).



TYRES

This vehicle is provided with tubeless tyres.

⚠ WARNING

Periodically check the tyre inflation pressure at room temperature, see p. 63 (TECHNICAL DATA).

If the tyres are hot, the measurement is not correct.

Carry out the measurement especially before and after long rides.

If the inflation pressure is too high, the ground unevenness cannot be dampened and is therefore transmitted to the handlebar, thus compromising the driving comfort and reducing road holding during turns.

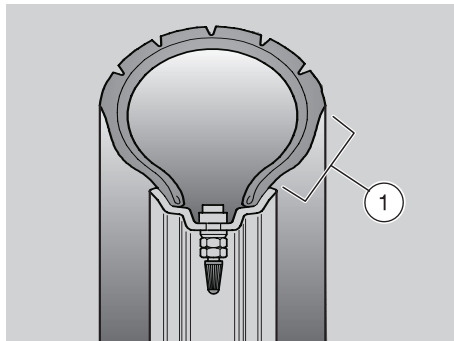

If, on the contrary, the inflation pressure is too low, the tyre sides (1) are under greater stress and the tyre itself may slip on the rim or it may become loose, with consequent loss of control of the vehicle.

In case of sudden braking the tyres could even get out of the rims. Further, the vehicle could skid while turning.

Check the surface and the wear of the tyres, since tyres in bad conditions can impair both the grip and the controllability of the vehicle.

Some types of tyres homologated for this vehicle are provided with wear indicators.

There are several kinds of wear indicators.

For more information on how to check the wear, contact your Dealer.

Visually check if the tyres are worn and in this case have them changed.

If the tyres are old, even if not completely worn out, they may become hard and may not ensure good road holding. In this case, have the tyres changed.

Change the tyre when it is worn out or in case of puncture on the tread side, if the puncture is larger than 5 mm.

After repairing a tyre, have the wheels balanced.

Use only tyres in the size suggested by **aprilia**, see p. 63 (TECHNICAL DATA).

Do not install tyres with air tube on rims for tubeless tyres and viceversa.

Make sure that the tyres always have their valve sealing caps on, to prevent them from suddenly going flat.

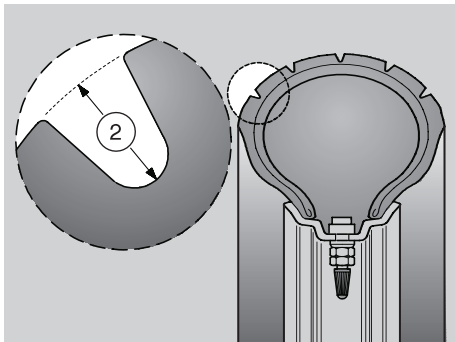

Change, repair, maintenance and balancing operations are very important and should be carried out by qualified technicians with appropriate tools.

For this reason, it is advisable to have the above mentioned operations carried out by an **aprilia Official Dealer or by a qualified tyre repairer.**

If the tyres are new, they may still be covered with a slippery film: drive carefully for the first miles. Do not oil the tyres with unsuitable fluids.

MINIMUM TREAD DEPTH LIMIT (2)

front: 2 mm (USA 3 mm)
 rear: 2 mm (USA 3 mm)



AUTOMATIC LIGHT SWITCHING VERSION ASD

The vehicles provided with this device can be immediately recognized, since the lights come automatically on as soon as the ignition switch is turned to position "O".

For this reason the light switch "☼ - ☼ - ●" has been replaced with a dimmer switch "☼ - ☼".

The lights can be switched off only by turning the ignition switch to position "☼".

- ◆ Before starting the vehicle, make sure that the dimmer switch is in position "☼" (front low beam).

EXHAUST SILENCER

⚠ WARNING

Tampering with the noise control system is prohibited.

Owners are warned that the law may prohibit:

- the removal or rendering inoperative by any person, other than for purposes of maintenance, repair or replacement, of any device or element of design incorporated into any new vehicle – for the purpose of noise control – prior to its sale or delivery to the ultimate purchaser or while it is in use; and
- the use of the vehicle after such device or element of design has been removed or rendered inoperative by any person.

Check the exhaust silencer and the silencer pipes, making sure that there are neither signs of rust, nor holes and that the exhaust system works effectively.

If the noise produced by the exhaust system increases, immediately contact your **aprilia** Official Dealer.

INSTRUCTIONS FOR USE

WARNING



Before departure, always carry out a preliminary checking of the vehicle, to make sure that it functions correctly and safely, see the following table (PRELIMINARY CHECKING OPERATIONS).

The non-performance of these checking operations can cause severe personal injuries or damage to the vehicle.

Do not hesitate to consult your **aprilia** Official Dealer in case there is something you do not understand about the functioning of some controls or in case you suspect or discover some irregularities.

It does not take long to carry out a check-up and this operation ensures you much more safety.

PRELIMINARY CHECKING OPERATIONS

Component	Check	Page
Front and rear disc brakes	Check the functioning, the idle stroke of the control levers, the fluid level and make sure there are no leaks. Check the wear of the pads. If necessary, top up the brake reservoir.	24, 43
Brake levers	Make sure that they work smoothly. If necessary, lubricate the articulations.	–
Accelerator	Make sure that it works smoothly and that it is possible to open and close it completely, in all steering positions. If necessary, adjust and/or lubricate it.	50
Wheel/tyres	Check the tyre surface, the inflation pressure, wear and tear and any damage.	28
Steering	Make sure that the steering rotates smoothly, without any clearance or slackening.	46
Side stand  (series ) and centre stand	Make sure that they work smoothly and that the spring tension brings them back to their normal position. If necessary, lubricate joints and hinges.	44
Fastening elements	Make sure that the fastening elements are not loose. If necessary, adjust or tighten them.	–
Fuel tank	Check the fuel level and top up, if necessary. Make sure there are no leaks or occlusions in the circuit. Make sure the filler cap is correctly tightened.	22, 60
Coolant	The coolant level in the expansion tank must be included between the "MIN" and "MAX" marks.	26, 27
Engine stop switch (○ - )	Make sure that it functions correctly.	17
Lights, warning lights, horn and electrical devices	Check the proper functioning of the acoustic and visual devices. Change the bulbs or carry out the necessary repairs in case of failure.	52 – 59

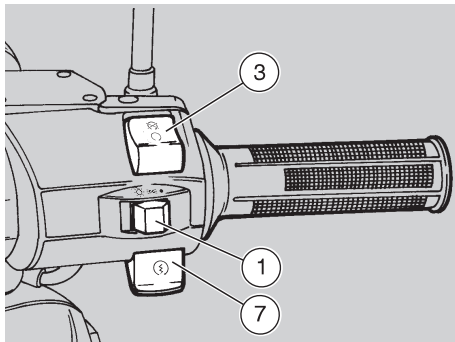

STARTING

⚠ WARNING

Exhaust gases contain carbon monoxide, which is extremely noxious if inhaled. Avoid starting the vehicle in closed or badly-ventilated rooms.

The non-observance of this warning may cause loss of consciousness or even lead to death by asphyxia.

Do not get on the vehicle for the starting. Do not start the engine with the vehicle positioned on the side stand.

- ◆ To start the vehicle, position it on the centre stand.
- ◆ Make sure that the light switch (1) is in position “●”.
- ◆ Make sure that the dimmer switch (2) is in position “☞”.

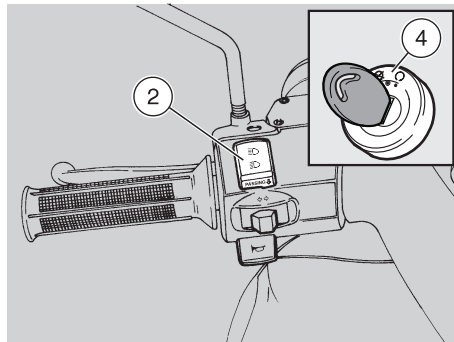

- ◆ Move the engine stop switch (3) to position “○”.
- ◆ Rotate the key (4) and move the ignition switch to position “○”.



⚠ CAUTION

At this point the engine oil pressure warning light “” (5) positioned on the dashboard comes on and remains on until the engine starts.

- ◆ Lock at least one wheel, by pulling a brake lever (6).
If this operation is not carried out, the start relay receives no current and therefore the engine does not start.

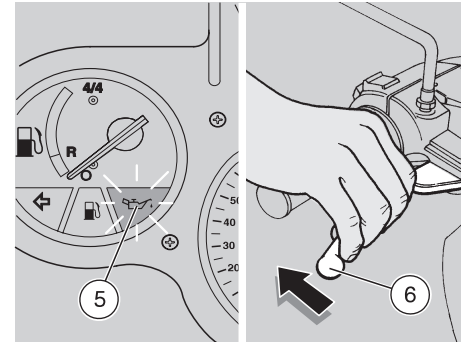
NOTE After a long period of inactivity, carry out the operations described at p. 33 (STARTING AFTER A LONG PERIOD OF INACTIVITY).



NOTE To avoid the excessive wear of the battery, do not keep the start push button “” pressed for more than five seconds (ten after a long period of inactivity). If the engine does not start within this lapse of time, wait ten seconds and press the start push button “” again.

⚠ CAUTION

Avoid pressing the start push button “” (7) when the engine is running, since you may damage the starter.

- ◆ Press the start push button “” (7) without accelerating and release it as soon as the engine starts.

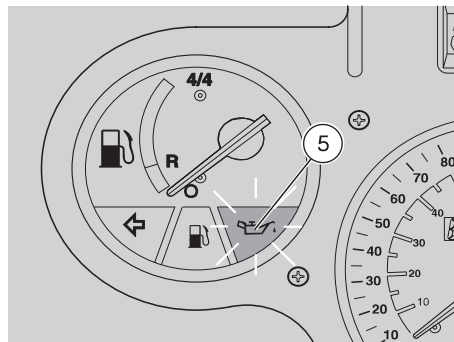
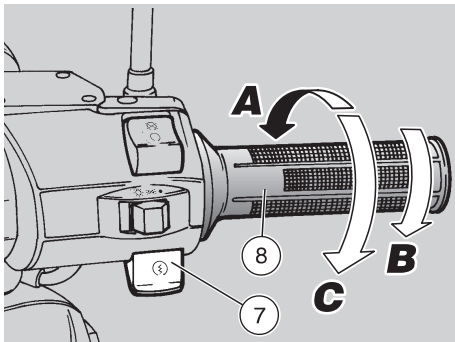

- ◆ If the engine does not start in three or four seconds, slightly rotate the throttle grip (8) (Pos. B), keeping the start push button "Ⓢ" (7) pressed.

⚠ CAUTION

As soon as the engine has started, the engine oil pressure warning light "Ⓢ" (5) must go out.

If this does not occur, or if the warning light comes on while the engine is running, this means that the pressure in the circuit is insufficient.

In this case, stop the engine immediately and contact an **aprilia** Official Dealer.

Do not use the vehicle with insufficient engine oil, in order to avoid damaging the engine components.

- ◆ Keep at least one brake lever pulled and do not accelerate until you start.

⚠ CAUTION

Never leave abruptly with cold engine. To reduce the emission of polluting substances and the consumption of fuel, warm the engine up by proceeding at low speed for the first miles.

STARTING WITH FLOODED ENGINE

If the starting is not carried out properly or if there is too much fuel in the intake ducts and in the carburettor, the engine may get flooded.

To clean a flooded engine:

- ◆ Press the start push button "Ⓢ" (7) for a few seconds (letting the engine spin over) with completely open throttle (8) (Pos. C).

STARTING WITH COLD ENGINE

When the room temperature is low (near or below 0°C), it may be difficult to start the engine at the first attempt.

In this case:

- ◆ Keep the start push button "Ⓢ" (7) pressed for five seconds and at the same time rotate the throttle grip (8) moderately (Pos. B).

If the engine starts.

- ◆ Release the throttle grip (8) (Pos. A).
- ◆ If the idling is unstable, twist the throttle grip (8) slightly and frequently.

If the engine does not start.

- ◆ Wait a few seconds and repeat the cold START PROCEDURE.
- ◆ If necessary, remove the spark plug, see p. 51 (SPARK PLUG) and make sure that it is not wet.
- ◆ If the spark plug is wet, clean and dry it.

Before reinstalling it:

NOTE Put a clean cloth on the cylinder, near the spark plug seat, in order to protect it from oil sprays.

- ◆ Press the start push button "Ⓢ" (7) and let the starter run for about five seconds without accelerating.

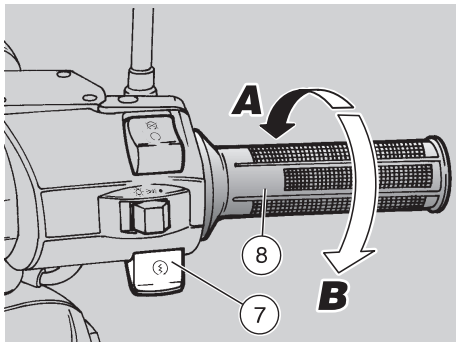

STARTING AFTER A LONG PERIOD OF INACTIVITY

After a long period of inactivity, if the start is not immediate, this may be due to the fact that the fuel circuit is partially empty.

In this case:

- ◆ Press the start push button “(8)” (7) for about ten seconds, in order to ensure the filling of the float chamber.

DEPARTURE AND DRIVE

NOTE Before departure, carefully read the "safe drive" chapter, see p. 5 (SAFE DRIVE).

⚠ CAUTION

If the low fuel warning light “(9)” (9) positioned on the dashboard comes on while the vehicle is running, this means that the electric reserve is operating and there are still 2/3 of fuel available. Refuel as soon as possible, see p. 22 (FUEL).

⚠ WARNING

If you drive without passenger, make sure that the passenger footrests are folded.

While riding, keep your hands on the grips and your feet on the footrests.

NEVER RIDE IN ANY POSITION OTHER THAN THOSE INDICATED.

If you drive with a passenger, instruct him/her so that he/she does not create problems during manoeuvres.

Before leaving, make sure that the stand/stands is/are completely up.

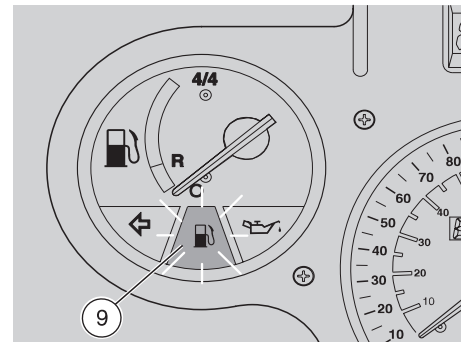

To leave:

- ◆ Release the throttle grip (8) (pos. A), put on the rear brake, then move the vehicle down the stand.
- ◆ Get on the vehicle, keeping at least one foot on the ground in order not to lose balance.
- ◆ Adjust the inclination of the rear-view mirrors correctly.

⚠ WARNING

With the vehicle at rest, try to get acquainted with the use of the rear-view mirrors. The reflecting surface is convex, therefore the objects seem to be farther away than they actually are. These mirrors offer a “wide-angle” view and only experience will allow you to evaluate the distance of the following vehicles correctly.

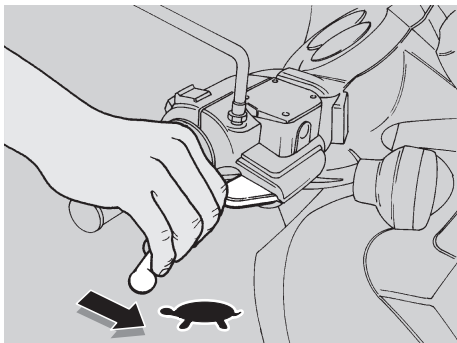

- ◆ Release the brake lever and accelerate by rotating the throttle grip moderately (**Pos. B**); the vehicle will start moving.

⚠ CAUTION

Never leave abruptly with cold engine. To reduce the emission of polluting substances and the consumption of fuel, warm the engine up by proceeding at low speed for the first miles.

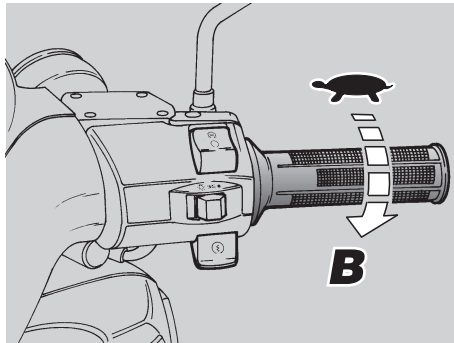

⚠ WARNING

Avoid opening and closing the throttle repeatedly and continuously, so that you do not accidentally lose control of the vehicle.

If you have to brake, close the throttle and put on both brakes in order to obtain uniform deceleration, properly exerting pressure on the braking parts. By putting on the front brake only or the rear brake only, you reduce the braking force considerably, thus running the risk of locking one wheel and consequently losing grip.

If you stop uphill, decelerate completely and use the brakes only to keep the vehicle steady. The use of the engine to keep the vehicle at a halt may cause the overheating of the speed variator.

⚠ WARNING

Before beginning to turn, slow down or brake driving at moderate and constant speed or accelerating slightly; avoid braking at the last moment: it would be very easy to skid.

If the brakes are operated continuously on downhill stretches, the friction material may overheat, thus reducing the braking efficiency. Exploit the engine compression by putting on both brakes intermittently. Never drive downhill with the engine off!

In case of wet road or scarce wheel grip (snow, ice, mud, etc.), drive slowly, avoiding sudden brakings or manoeuvres that could make you lose grip and fall down.

Pay the utmost attention to any obstacle or variation of the road surface. Uneven roads, rails, manhole covers, indications painted on the road surface, building site metal plates become rather slippery by rain. For this reason all these obstacles have to be carefully avoided, driving smoothly and bending the vehicle as little as possible.

⚠ WARNING

Always use the direction indicators in time when you intend to change lane or direction, avoiding sharp and dangerous movements.

Switch off the direction indicators as soon as you have changed direction.

Be extremely careful when you overtake other vehicles or are overtaken.

In case of rain, the water cloud created by big vehicles reduces visibility; the air shift may make you lose control of the vehicle.

RUNNING-IN

⚠ WARNING

After the first 1000 km (625 mi), carry out the checking operations indicated in the column "After running-in" of the Regular Service Intervals Chart, see p. 38 (REGULAR SERVICE INTERVALS CHART), in order to avoid hurting yourself or other people and/or damaging the vehicle.

The running-in of the engine is primary to ensure its working life and its correct functioning. If possible, drive on hilly roads and/or roads with many bends, so that the engine, the suspensions and the brakes undergo a more effective running-in.

NOTE Only after the first 500 km (312 mi) of running-in it is possible to obtain the best speed and acceleration performance from the vehicle.

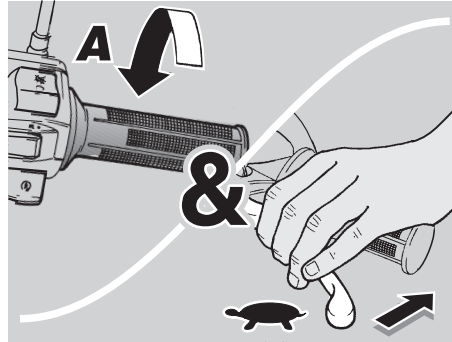

Keep to the following indications:

- ◆ Do not open the throttle completely if the speed is low, both during and after the running-in.
- ◆ **0-100 km (0-62 mi)**
During the first 100 km (62 mi) put on the brakes with caution, avoiding sharp and prolonged brakings.
This ensures a correct bedding-in of the pads on the brake disc.
- ◆ **0-500 km (0-312 mi)**
During the first 500 km (312 mi), do not exceed the 80% of the maximum allowed speed.
- ◆ Avoid driving at constant speed for long distances.
- ◆ After the first 1000 km (625 mi), progressively increase the speed until reaching the highest performance levels.

STOPPING

⚠ WARNING

If possible, avoid stopping abruptly, slowing down suddenly and braking at the last moment.

- ◆ Release the throttle grip (**pos. A**) and gradually put on the brakes to stop the vehicle.
- ◆ In case of a brief stop, keep at least one brake on.

PARKING

⚠ WARNING

Park the vehicle on firm and flat ground, to prevent it from falling down.

Neither lean the vehicle against walls, nor lay it on the ground.

Make sure that the vehicle and especially its red-hot parts do not represent a danger for persons and children.

Do not leave the vehicle unattended when the engine is on or the key is inserted into the ignition switch.

Do not sit on the vehicle when the stand is down.

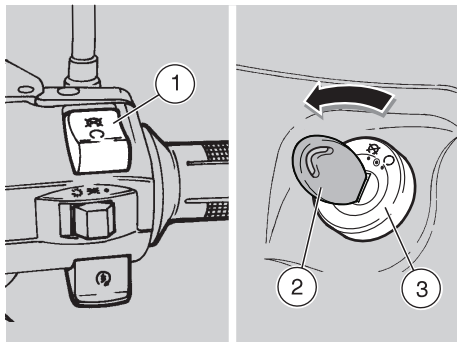

- ◆ Stop the vehicle, see p. 35 (STOPPING).
- ◆ Move the engine stop switch (1) to position “X”.

⚠ CAUTION

With stopped engine and ignition switch in position “○”, the battery may run down.

- ◆ Rotate the key (2) and move the ignition switch (3) to position “X”.
- ◆ Position the vehicle on the stand, see beside (POSITIONING THE VEHICLE ON THE STAND).

NOTE It is not necessary to close the fuel tap when the engine is off, since it is equipped with an automatic closing system.

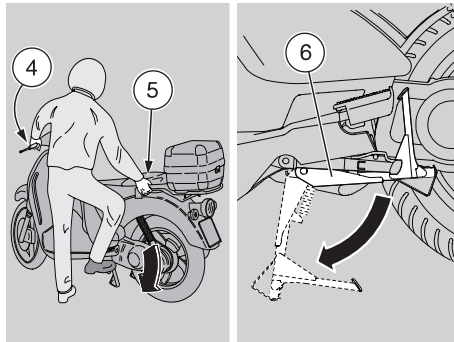

⚠ CAUTION

Never leave the key in the ignition switch.

- ◆ Lock the steering, see p. 18 (STEERING LOCK) and extract the key.

POSITIONING THE VEHICLE ON THE STAND

Carefully read p. 35 (PARKING).

CENTRE STAND

- ◆ Grasp the left grip (4) and the passenger grab rail (5).
- ◆ Push down the stand lever (6).

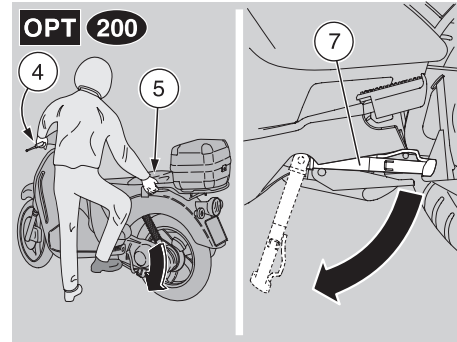

SIDE STAND **OPT** (series **200**)

- ◆ Grasp the left grip (4) and the passenger grab rail (5).

⚠ WARNING

Danger of fall or overturning. When the vehicle is straightened from the parking position to the driving position, the stand goes automatically up.

- ◆ Press the side stand (7) with your right foot and extend it completely.
- ◆ Incline the vehicle until the stand rests on the ground.
- ◆ Steer the handlebar completely leftwards.

⚠ WARNING

Make sure that the vehicle is stable.

SUGGESTIONS TO PREVENT THEFT

NEVER leave the ignition key inserted and always use the steering lock.

Park the vehicle in a safe place, possibly in a garage or a protected place.

If possible, use the appropriate **aprilia** "Body-Guard" armored cable **OPT**, or an additional anti-theft device.

Make sure that all documents are in order and the road tax has been paid.

Write down your personal data and telephone number in the space provided in this page, to facilitate the identification of the owner in case of finding after theft.

SURNAME:

NAME:

ADDRESS:

.....

TELEPHONE NO.:

NOTE Very often stolen vehicles are identified thanks to the data written on the use/maintenance manual.

MAINTENANCE

WARNING

Risk of fire. Keep fuel and other flammable substances away from the electrical components.

Before beginning any maintenance operation or any inspection of the vehicle, stop the engine, extract the key from the ignition block, wait until the engine and the exhaust system have cooled down and if possible lift the vehicle by means of the proper equipment, on firm and flat ground.

Before proceeding, make sure that the room in which you are working is properly ventilated.

Keep away from the red-hot parts of the engine and of the exhaust system, in order to avoid burns.

Do not hold any mechanical piece or other parts of the vehicle with your mouth: the components are not edible and some of them are noxious or even toxic.

The vehicle is made up of not edible parts. Never bite, suck, chew or swallow any part of the vehicle for any reason.

CAUTION

If not expressly indicated otherwise, for the reassembly of the units repeat the disassembly operations in reverse order.

In case any maintenance operation has to be carried out, it is advisable to use latex gloves.

Normally, the routine maintenance operations can be performed by the user; however, in some cases the use of specific tools and technical expertise may be required.

If you need assistance or technical advice, consult your **aprilia** Official Dealer, who can ensure you prompt and accurate servicing.

Ask your **aprilia** Official Dealer to test the vehicle on the road after a repair or periodic maintenance operation.

In any case, personally carry out the "Preliminary checking operations" after any maintenance operation, see p. 30 (PRELIMINARY CHECKING OPERATIONS).

REGULAR SERVICE INTERVALS CHART

OPERATIONS TO BE CARRIED OUT BY THE **aprilia** Official Dealer (WHICH CAN BE CARRIED OUT EVEN BY THE USER).

Key

- ① = check and clean, adjust, lubricate or change, if necessary;
- ② = clean;
- ③ = change;
- ④ = adjust.

NOTE Carry out the maintenance operations more frequently if you use the vehicle in rainy and dusty areas or on uneven ground.

Component	After run-ning-in [1000 km (625 mi)]	Every 6000 km (3750 mi) or 12 months	Every 12000 km (7500 mi) or 24 months
Battery - Terminal fastening - Electrolyte level	①	①	–
Spark plug	①	③	–
Carburettor - idling	④	①	–
Air cleaner	–	②	–
Accelerator operation	①	①	–
Brake locking operation	①	①	–
Light system	①	①	–
Stop light switches	–	①	–
Brake fluid	①	①	–
Coolant	①	every 2000 km (1250 mi): ①	
Engine oil	every 1000 km (625 mi): ①		
Headlight beam direction - operation	–	①	–
Wheels/tyres and inflation pressure	every month: ④		
Engine oil pressure Warning light	at every start: ①		
Front and rear brake pad wear	①	every 2000 km (1250 mi): ①	

OPERATIONS TO BE CARRIED OUT BY THE aprilia Official Dealer.

Key

① = check and clean, adjust, lubricate or change, if necessary;

② = clean;

③ = change;

④ = adjust.

NOTE Carry out the maintenance operations more frequently if you use the vehicle in rainy and dusty areas or on uneven ground.

Component	After running in [1000 km (625 mi)]	Every 6000 km (3750 mi) or 12 months	Every 12000 km (7500 mi) or 24 months
Rear shock absorber	–	–	①
Transmission cables and controls	①	①	–
Accelerator cable (adjustment)	①	①	–
Variator belt	–	①	③
Steering tube bearings and steering slack	①	①	–
Wheel bearings	–	①	–
Brake discs	①	①	–
Engine oil filter	③	③	–
General running of the vehicle	①	①	–
Valve clearance	④	④	–
Speed change gear grease	–	–	③
Braking systems	①	①	–
Cooling system	①	①	–
Stop light switches	–	①	–
Brake fluid	every 6000 km (3750 mi): ① / every 2 years: ③		
Coolant	every 2000 km (1250 mi): ① / every 2 years: ③		
Fork oil and oil seal	every 12000 km (7500 mi): ①		
Engine oil	③	①	③
Transmission oil	③	①	③
Guide pins (# 3 pieces) (rear)	every 12000 km (7500 mi): ③		
Front pulleys (# 2 pieces)	every 18000 km (11250 mi): ③		
Engine oil filter screen and magnetic screw	①	①	–
Guide rollers (# 3 pieces) (rear)	every 12000 km (7500 mi): ③		
Speed change gear rollers and speed change gear plastic guides	–	①	③
Wheels/tyres and inflation pressure	–	①	–
Inner spring cap (rear)	every 12000 km (7500 mi): ③		
Nut, bolt, screw tightening	①	①	–
Cylinder head nut fastening	①	–	–
Fuel pipe	–	①	every 4 years: ③
Clutch wear	–	①	–



IDENTIFICATION DATA

It is a good rule to write down the frame and engine numbers in the space provided in this manual.

The frame number can be used for the purchase of spare parts.

NOTE Do not alter the identification numbers if you do not want to incur severe penal and administrative sanctions. In particular, the alteration of the frame number results in the immediate invalidity of the guarantee.

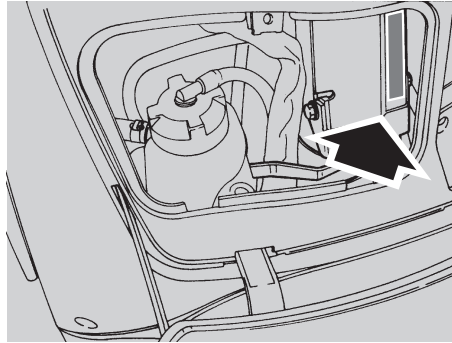

FRAME NUMBER

The frame number is stamped on the frame central tube. To read it, it is necessary to remove the front inspection cover, see p. 49 (REMOVING THE FRONT INSPECTION COVER)

Frame no. _____

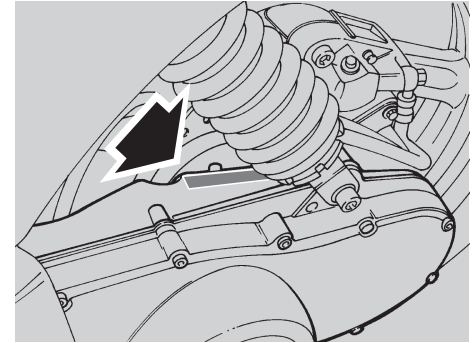

ENGINE NUMBER

The engine number is stamped near the lower support of the rear shock absorber.

Engine no. _____

CHECKING THE ENGINE OIL LEVEL AND TOPPING UP

Carefully read p. 23 (LUBRICANTS), p. 37 (MAINTENANCE) and p. 68 (LUBRICANT CHART).

CHECKING

NOTE Position the vehicle on firm and flat ground.

- ◆ Position the vehicle on the centre stand.

WARNING

The engine and the components of the exhaust system become very hot and remain hot for some time after the engine has been stopped. Before handling these components, wear insulating gloves or wait until the engine and the exhaust system have cooled down.

- ◆ Stop the engine and let it cool down, in order to allow the oil to flow into the oil pan and to cool down.

NOTE The non-performance of the operations described above may result in the incorrect measurement of the engine oil level.

- ◆ Remove the central fairing, see p. 47 (REMOVING THE CENTRAL FAIRING).
- ◆ Unscrew and extract the plug/dipstick (1).

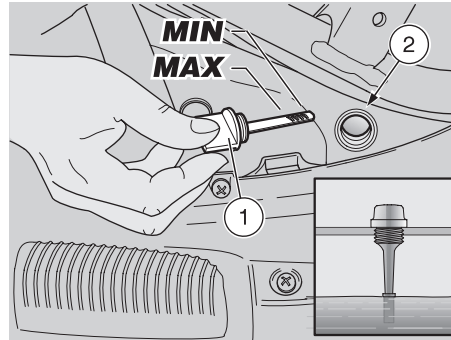

- ◆ Clean the part in contact with the oil with a clean cloth.
- ◆ Tighten the plug/dipstick (1) completely, screwing it into the filling hole (2).
- ◆ Withdraw the plug/dipstick (1) again and read the oil level on the dipstick itself:
MAX = maximum level;
MIN = minimum level.
The difference between "**MAX**" and "**MIN**" is about 150 cm³.
- ◆ The level is correct if the oil reaches approx. the "**MAX**" mark on the dipstick.

CAUTION

Never exceed the "**MAX**" mark, nor leave the oil below the "**MIN**" mark, in order to avoid serious damage to the engine.

- ◆ If necessary, provide for topping up.

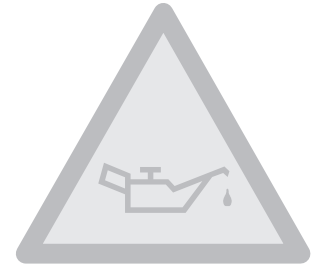

TOPPING UP

- ◆ Pour a small quantity of oil in the filling hole (2) and wait about one minute, so that the oil flows uniformly into the oil pan.
- ◆ Check the oil level and top up if necessary.
- ◆ Top up by adding small quantities of oil, until reaching the prescribed level.
- ◆ At the end of the operation, screw and tighten the plug/dipstick (1).

WARNING

Do not use the vehicle with insufficient lubrication or with contaminated or unsuitable lubricants, since this would accelerate the wear of the moving parts and may also cause irreparable failures.

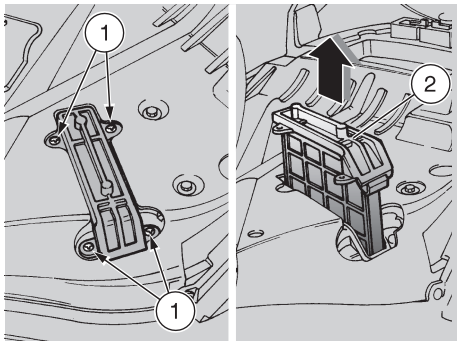

AIR CLEANER

Carefully read p. 37 (MAINTENANCE).

The air cleaner should be inspected and cleaned every 6000 km (3750 mi), depending on the conditions of use.

If the vehicle is used on dusty or wet roads, the cleaning operations should be carried out more frequently.

To clean the filtering element it is necessary to remove it from the vehicle.

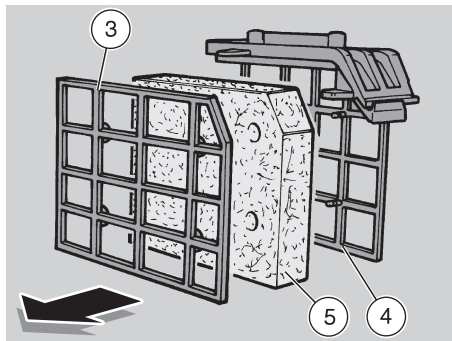

REMOVAL

- ◆ Raise the saddle, see p. 20 (UNLOCKING / LOCKING THE SADDLE).
- ◆ Unscrew and remove the screws (1).
- ◆ Withdraw the complete air cleaner from above.
- ◆ Separate the grid (3) from the support (4).
- ◆ Remove the filtering element (5).

CLEANING

⚠ WARNING

Do not use petrol or inflammable solvents to wash the filtering element, in order to avoid fires or explosions.

- ◆ Wash the filtering element (5) with clean, non-inflammable solvents or solvents with high volatility point, then let it dry thoroughly.

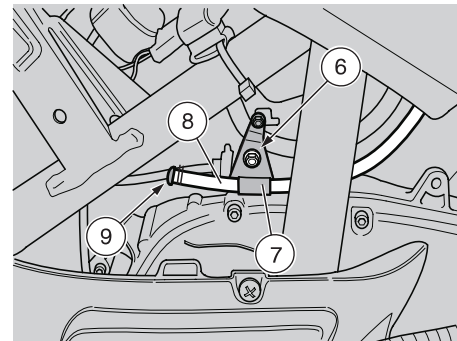

- ◆ Apply a filter oil on the whole surface of the filtering element.
- ◆ Remove the central fairing, see p. 47 (REMOVING THE CENTRAL FAIRING) and check if there are impurities in the lower part of the drain pipe (8).

If there are residues coming from the filter case, remove them by proceeding as follows:

- ◆ Loosen the screw (6).
- ◆ Withdraw the pipe (8) from the clamp (7).
- ◆ Remove the small plug (9).
- ◆ Empty the contents into a container and deliver it to a salvage centre.

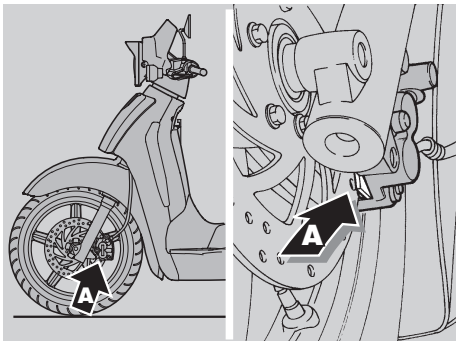

CHECKING THE BRAKE PAD WEAR

Carefully read p. 24 (BRAKE FLUID-recommendations), (DISC BRAKES) and p. 37 (MAINTENANCE).

NOTE The following information refers to a single braking system, but is valid for both.

Check the brake pad wear after the first 1000 km (625 mi) and successively every 2000 km (1250 mi). The wear of the brake pads depends on the use, on the kind of drive and on the road.

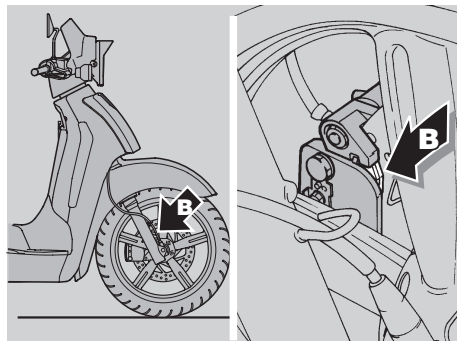

⚠ WARNING

Check the wear of the brake pads especially before every trip.

To carry out a rapid checking of the pad wear, proceed as follows:

- ◆ Position the vehicle on the centre stand.
- ◆ Carry out a visual check between the brake disc and the pads.

Use a flashlight and a mirror, proceed as follows:

FRONT BRAKE CALIPER

- From below, on the front part, for the left pad (A);
- from above, on the front part, for the right pad (B).

REAR BRAKE CALIPER

- From above, on the rear part, for both pads (C).

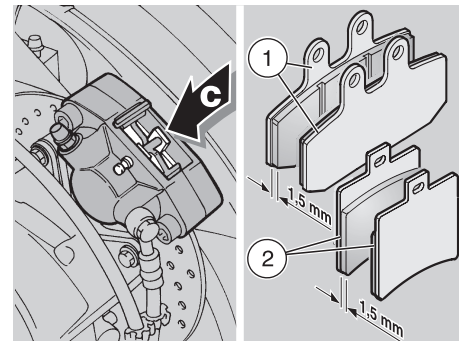

⚠ WARNING

The excessive wear of the friction material would cause the contact of the pad metal support with the disc, with consequent metallic noise and production of sparks from the caliper; braking efficiency, safety and soundness of the disc would thus be negatively affected.

- ◆ If the thickness of the friction material (even of one pad only) has reduced to about **1,5 mm** (or if even only one of the wear indicators is not visible any longer), change both pads.

- Front pads (1);
- rear pads (2).

⚠ WARNING

Have the pads changed by your **aprilia** Official Dealer.

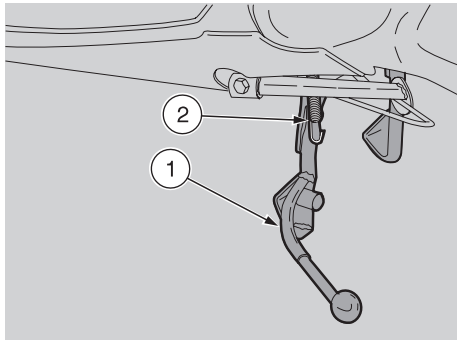

CHECKING THE STAND

Carefully read p. 37 (MAINTENANCE).

⚠ WARNING

FOR THE SIDE STAND ONLY OPT (series 200).

Danger of fall or overturning.

When the vehicle is straightened from the parking position to the driving position, the stand goes automatically up.

NOTE The following information refers to one stand only, but is valid for both.

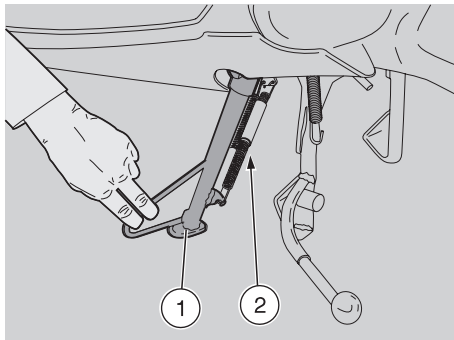

The stand (1) must rotate without hindrances.

Carry out the following checks:

- ◆ The springs (2) must not be damaged, worn, rusty or weakened.
- ◆ The stand must rotate freely, if necessary grease the joint, see p. 68 (LUBRICANT CHART).

INSPECTING THE FRONT AND REAR SUSPENSIONS

Carefully read p. 37 (MAINTENANCE).

⚠ CAUTION

To have the front suspension oil changed, contact your **aprilia Official Dealer, who will ensure you prompt and accurate servicing.**

Have the front suspension oil and fork oil seals checked every 12000 km (7500 mi) or every 2 years.

Carry out the following checks after the first 1000 km (625 mi) and successively every 6000 km (3750 mi):

- ◆ With pulled front brake lever, push the fork repeatedly downwards. The stroke must be gentle and there must be no trace of oil on the rods.
- ◆ Check the fastening of all the components and the functionality of the front and rear suspension joints.

⚠ CAUTION

If you notice irregularities in the operation or if the help of a qualified technician is necessary, contact your **aprilia Official Dealer.**



ADJUSTING THE REAR SUSPENSION

The rear suspension consists of a double-effect shock absorber (braking with compressed/extended shock absorber) fixed to the engine by means of a silent-block.

The shock absorber is provided with a ring nut for the adjustment of the spring preload.

The standard adjustment, set by the manufacturer, is suitable for a driver weighing about 70 kg.

If your weight and needs are different, adjust the ring nut (1) with the appropriate spanner provided in the tool kit, thus setting the ideal travelling conditions (see table).

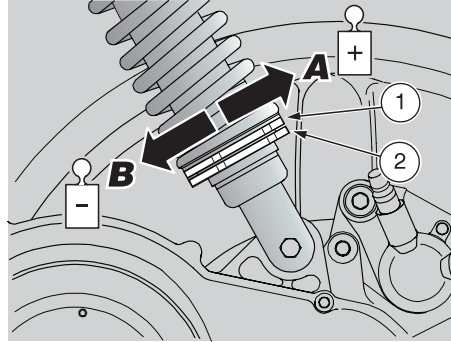

- ◆ Slightly unscrew the locking ring nut (2) by means of the appropriate spanner.

⚠ CAUTION

The adjusting metal ring must not be screwed for more than 14 mm. If this limit is exceeded, even the slightest unevenness of the ground will make the vehicle jerk while running.

- ◆ Act on the adjusting ring nut (3) (shock absorber spring preload adjustment) (see figure).
- ◆ Once the optimal attitude has been obtained, tighten the locking ring nut (2) completely.

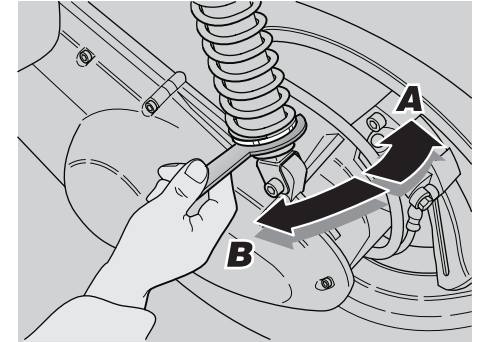

ADJUSTMENT OF THE REAR SUSPENSION SPRING PRELOAD

Adjusting ring	Rotation (arrow A)	Rotation (arrow B)
Function	Spring preload increase	Spring preload decrease
Attitude	The vehicle is more rigid	The vehicle is less rigid
Recommended kind of road	Smooth or normal roads	Roads with uneven surface
Notes	Drive with passenger	Drive without passenger

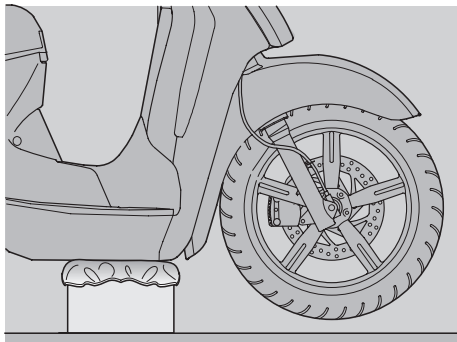

CHECKING THE STEERING

Carefully read p. 37 (MAINTENANCE).

Occasionally check the steering slack.

To check the steering:

- ◆ Position the vehicle on the centre stand.

NOTE Prepare a support whose height should be 200 mm and the support base must measure 200 x 200 mm.

- ◆ Place the support under the vehicle and a spongy cloth between them, so that the front wheel can move freely and the vehicle cannot fall down.

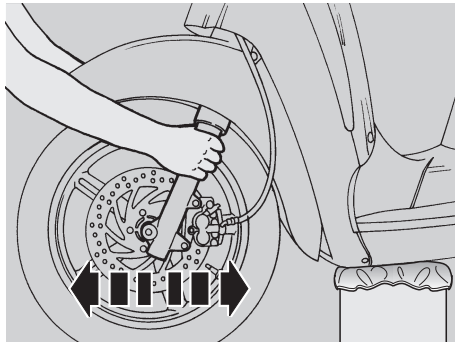

⚠ CAUTION

Make sure that the vehicle is stable.

- ◆ Shake the fork in the riding direction (see figure).

⚠ CAUTION

Do not shake the fork excessively, otherwise you may take in consideration the movement of the stand, thus observing an incorrect slack. Repeat the previous operation more than once.

- ◆ If you find that there is a considerable slack, contact your **aprilia** Official Dealer to restore the optimal steering conditions.

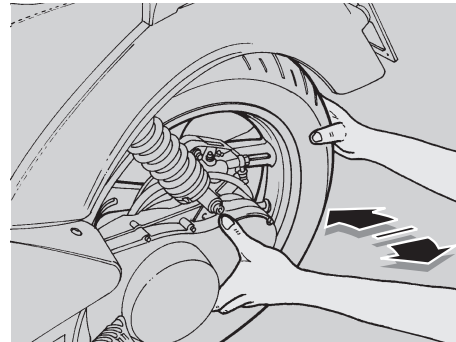

CHECKING THE ENGINE FULCRUM AXIS

Carefully read p. 37 (MAINTENANCE).

Periodically check the slack existing between the engine pin bushings.

To carry out this operation, proceed as follows:

- ◆ Position the vehicle on the centre stand.
- ◆ Shake the wheel transversally with respect to the riding direction.
- ◆ If any slack should be noticed, contact your **aprilia** Official Dealer, to restore the optimal operating conditions.

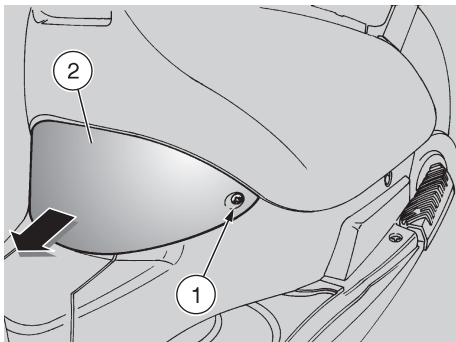

REMOVING THE CENTRAL INSPECTION COVER

Carefully read p. 37 (MAINTENANCE).

- ◆ Position the vehicle on the centre stand.
- ◆ ★ Unscrew and remove the screw (1).

⚠ CAUTION

Proceed with care.

Do not damage the tangs and/or their seats.

Handle the plastic and painted components with care and avoid scraping or damaging them.

- ◆ Remove the central inspection cover (2).

⚠ CAUTION

Upon reassembly, fit the tangs correctly in the appropriate seats.

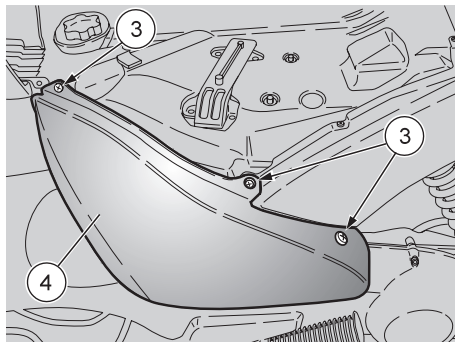

REMOVING THE CENTRAL FAIRING

Carefully read p. 37 (MAINTENANCE).

- ◆ Remove the central inspection cover, see beside (REMOVING THE CENTRAL INSPECTION COVER).
- ◆ Raise the saddle, see p. 20 (UNLOCKING / LOCKING THE SADDLE).
- ◆ ★ Unscrew and remove the screws (3).

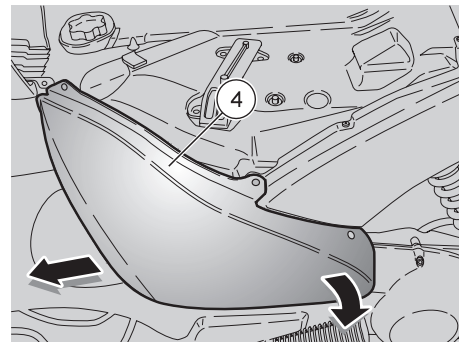

⚠ CAUTION

Proceed with care. Do not damage the tangs and/or the relevant seats. Handle the painted and plastic components with care, without scratching or damaging them.

- ◆ Moderately open the rear part of the central fairing (5).
- ◆ Remove the central fairing (5) by withdrawing it from the front.

⚠ CAUTION

Upon reassembly, fit the tangs correctly in the appropriate seats.

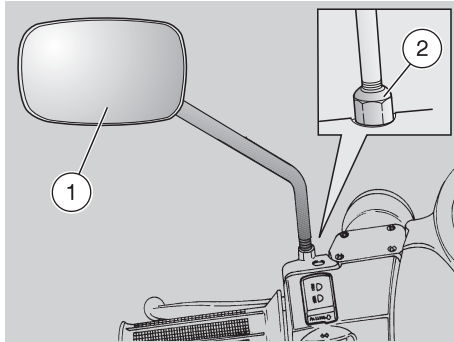

REMOVING THE REAR-VIEW MIRRORS

Carefully read p. 37 (MAINTENANCE).

- ◆ Position the vehicle on the centre stand.

NOTE The rear-view mirrors are threaded:

- on the right (left mirror);
- on the left (right mirror).

In case of accidental impact, the rear-view mirror will rotate backwards, thus reducing the width of the vehicle. To move the mirror back to its initial position, rotate it in the opposite direction until reaching the end of stroke; if necessary, adjust the nut (2).

⚠ CAUTION

Hold the rear-view mirror (1), to prevent it from accidentally falling down.

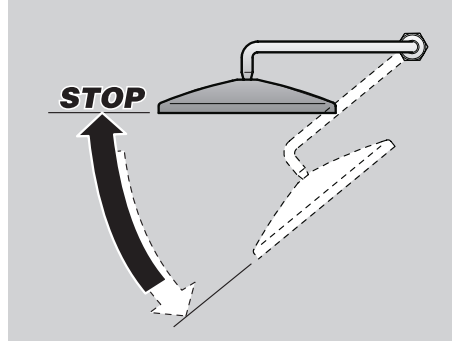

- ◆ Unscrew and remove the rear-view mirror (1) (anticlockwise rotation for the left mirror and clockwise rotation for the right mirror).

Upon reassembly:

- ◆ Screw the mirror (1) by giving it at least three turns (clockwise rotation for the left mirror and anticlockwise rotation for the right mirror).
- ◆ Position the mirror (1) in such a way as to improve visibility as much as possible.
- ◆ Lock the mirror (1) in its position by adjusting the stop nut (2) (clockwise rotation for the left nut, anticlockwise rotation for the right nut).

NOTE The right stop nut is provided with a line that distinguishes it from the left nut.

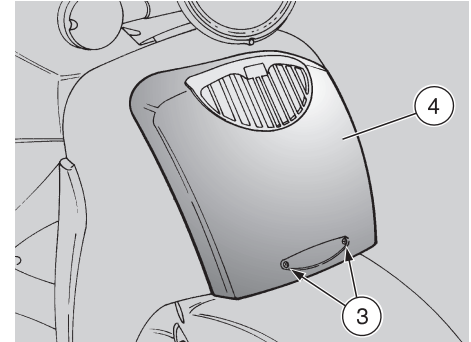

REMOVING THE FRONT COVER

Carefully read p. 37 (MAINTENANCE).

- ◆ Position the vehicle on the centre stand.
- ◆ Unscrew and remove the screws (3).

⚠ CAUTION

Proceed with care.

Do not damage the tangs and/or their seats.

Handle the plastic and painted components with care and avoid scraping or damaging them.

- ◆ Remove the front cover (4) by pulling it downwards.

⚠ CAUTION

Upon reassembly, fit the tangs correctly in the appropriate seats.

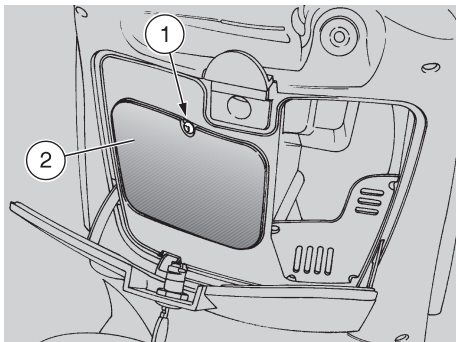

REMOVING THE FRONT INSPECTION COVER

Carefully read p. 37 (MAINTENANCE).

- ◆ Open the glove compartment, see p. 21 (GLOVE COMPARTMENT).
- ◆ Unscrew and remove the screw (1).
- ◆ Remove the front inspection cover (2).

⚠ CAUTION

Upon reassembly, fit the tangs correctly in the appropriate seats.

REMOVING THE CRASH HELMET CASE

Carefully read p. 37 (MAINTENANCE).

- ◆ Position the vehicle on the centre stand.
- ◆ Open the crash helmet case (3), see p. 20 (CRASH HELMET CASE).

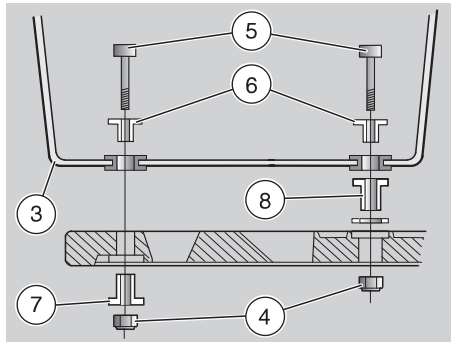

- ◆ Take the helmet and/or any other object out of the case (3).
- ◆ Unscrew and remove the screws (5), holding the nuts (4).

Screw (5) driving torque: 12 Nm (1.2 kgm).

- ◆ Take the nuts (4) and if necessary withdraw the spacers (6).
- ◆ Close the crash helmet case (3), raise and remove it.
- ◆ Withdraw the spacers (7), (8) and take the washers.

NOTE The front spacers must be withdrawn from the parcel grid (9) by pulling them upwards, while the rear spacer must be withdrawn by pulling it downwards.

Maximum allowed weight: 3 kg

Maximum allowed weight on the parcel grid (9): 9 kg

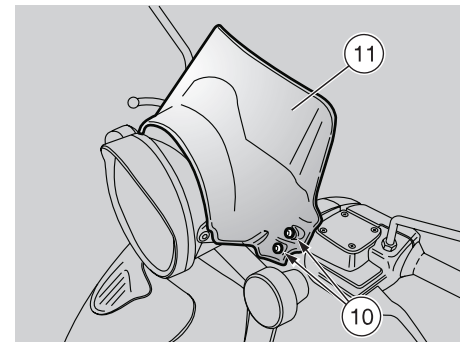
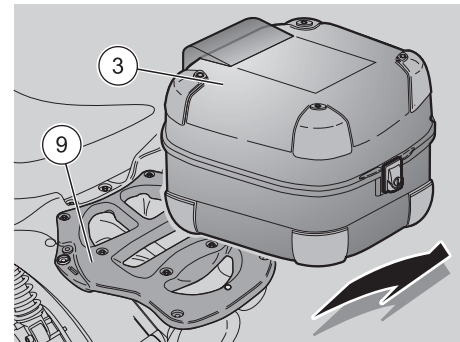

REMOVING THE FRONT PART OF THE FAIRING

Carefully read p. 37 (MAINTENANCE).

- ◆ Position the vehicle on the centre stand.
- ◆ ★ Unscrew and remove the two screws (10).
- ◆ Remove the front part of the fairing (11).

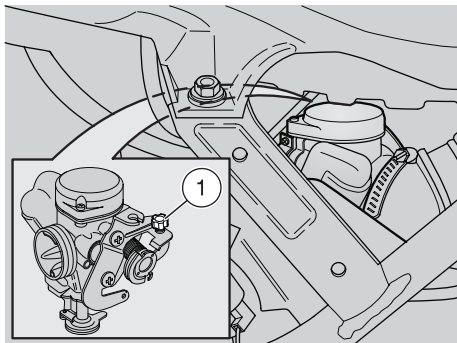

The engine minimum rpm must be approximately the following 1600 ± 50 rpm. In this case the engine does not make the rear wheel rotate.

If necessary:

- ◆ Working on the front left side of the vehicle, adjust the screw (1) positioned on the right side of the carburettor.

By **SCREWING IT** (clockwise), you increase the engine rpm.

By **UNSCREWING IT** (anticlockwise), you decrease the engine rpm.

- ◆ Act on the throttle grip, accelerating and decelerating a few times to make sure that it functions correctly and to check if the idling speed is constant.

NOTE Do not act on the air adjusting screw, to avoid variations of the carburation setting.

If necessary, contact your **aprilia** Official Dealer.

ADJUSTING THE ACCELERATOR CONTROL

Carefully read p. 37 (MAINTENANCE).

The idle stroke of the throttle grip must be **2 – 3 mm**, measured on the edge of the grip itself.

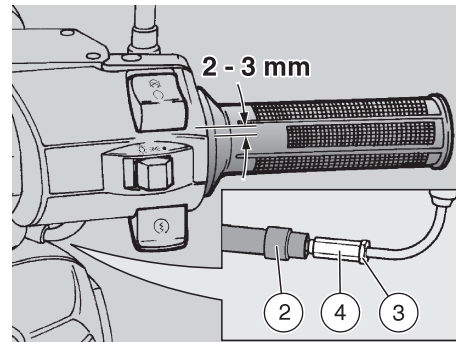

If this is not the case, proceed as follows:

- ◆ Position the vehicle on the centre stand.
- ◆ Withdraw the protection element (2).
- ◆ Loosen the lock nut (3).
- ◆ Rotate the adjuster (4) in such a way as to restore the prescribed value.
- ◆ After the adjustment, tighten the lock nut (3) and check the idle stroke again.
- ◆ Put back the protection element (2).

⚠ WARNING

After the adjustment, make sure that the rotation of the handlebar does not modify the engine idling rpm and that the throttle grip returns smoothly and automatically to its original position after being released.

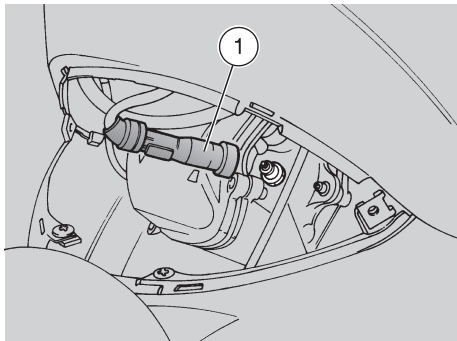

SPARK PLUG

Carefully read p. 37 (MAINTENANCE).

Check the spark plug after the first 1000 km (625 mi) and change it every 6000 km (3750 mi). Periodically remove the spark plug, eliminate any carbon deposits and change it if necessary.

To reach the spark plug:

- ◆ Remove the central inspection cover, see p. 47 (REMOVING THE CENTRAL INSPECTION COVER).

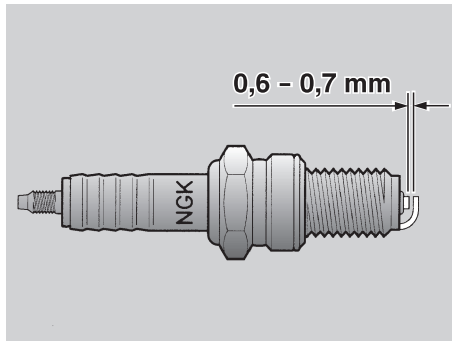

To remove and clean the spark plug:

⚠ WARNING

Before carrying out the following operations, let the engine and the exhaust silencer cool down until they reach room temperature, in order to avoid burns.

- ◆ Take off the spark plug cap (1).
- ◆ Remove all the dirt from the base of the spark plug, then unscrew it with the spanner you will find in the tool kit and extract it from its seat, taking care that neither dust nor other substances enter the cylinder.
- ◆ Make sure that there are neither carbon deposits, nor corrosion marks on the electrode and on the central porcelain part; if necessary, clean them with the special cleaners for spark plugs, with an iron wire and/or a metal brush.

- ◆ Energetically blow some air, in order to prevent the removed residues from getting into the engine.

If the spark plug has crackings on the insulating material, corroded electrodes or excessive deposits, it must be changed.

- ◆ Check the spark plug gap with a thickness gauge.

The gap must be **0,6 – 0,7 mm**; if necessary adjust it, carefully bending the earth electrode.

- ◆ Make sure that the washer is in good conditions. With the washer on, screw the spark plug by hand in order not to damage the thread.

- ◆ Tighten the spark plug by means of the spanner you will find in the tool kit, giving it half a turn to compress the washer.

**Spark plug driving torque:
18 Nm (1,8 kgm).**

⚠ CAUTION

The spark plug must be well tightened, otherwise the engine may overheat and be seriously damaged.

Use the recommended type of spark plug only, see p. 63 (TECHNICAL DATA), in order not to compromise the life and performance of the engine.

- ◆ Position the spark plug cap properly, so that it does not come off due to the vibrations of the engine.
- ◆ Put back the central inspection cover, see p. 47 (REMOVING THE CENTRAL INSPECTION COVER).

BATTERY

Carefully read p. 37 (MAINTENANCE).

Check the electrolyte level and the tightening of the terminals after the first 1000 km (625 mi) and then every 6000 km (3750 mi).

⚠ WARNING

Risk of fire.

Keep fuel and other flammable substances away from the electrical components.

The electrolyte in the battery is toxic and caustic and if it gets in contact with the skin it can cause burns, since it contains sulphuric acid. Wear protection clothes, a face mask and/or goggles during maintenance operations.

In case of contact with the skin, rinse with plenty of water.

In case of contact with the eyes, rinse with plenty of water for fifteen minutes, then consult an oculist without delay.

If the electrolyte is accidentally swallowed, drink a lot of water or milk, then continue drinking milk of magnesia or vegetable oil and consult a doctor without delay.

The battery gives off explosive gases; keep it away from flames, sparks, cigarettes and any other source of heat.

During the recharging or the use, make sure that the room is properly ventilated and avoid inhaling the gases released during the recharging.

KEEP AWAY FROM CHILDREN.

Do not incline the vehicle too much, in order to avoid dangerous leaks of the battery fluid.

⚠ CAUTION

Never invert the connection of the battery cables.

Connect and disconnect the battery with the ignition switch in position “ \otimes ”, otherwise some components may be damaged.

Connect first the positive cable (+) and then the negative cable (-).

Disconnect following the reverse order.

The electrolyte is corrosive.

Do not pour or spill it, especially on the plastic parts.

In case of installation of a “MAINTENANCE-FREE” battery, to recharge it use a specific recharger (type with constant voltage/ampereage or constant voltage).

The use of a traditional battery recharger may damage the battery.

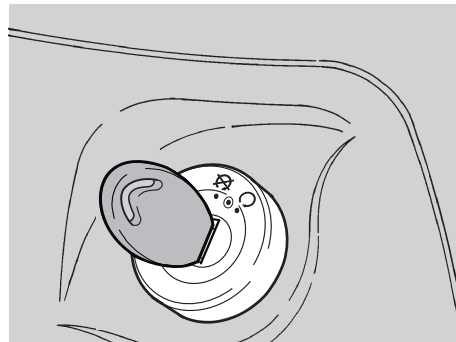

LONG INACTIVITY OF THE BATTERY

If the vehicle remains unused for more than fifteen days, it is necessary to recharge the battery, in order to prevent its sulphation, see p. 54 (RECHARGING THE BATTERY).

◆ Remove the battery, see p. 53 (REMOVING THE BATTERY) and put it in a cool and dry place.

It is important to check the charge periodically (about once a month), during the winter or when the vehicle remains unused, in order to prevent the deterioration of the battery.

◆ Recharge it completely with a normal charge, see p. 54 (RECHARGING THE BATTERY).

If the battery remains on the vehicle, disconnect the cables from the terminals.

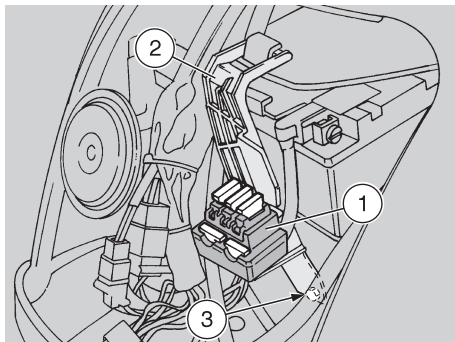

EXTRACTING THE BATTERY CASE

Carefully read p. 52 (BATTERY).

- ◆ Make sure that the ignition switch is in position "⊗".
- ◆ Remove the front cover, see p. 48 (REMOVING THE FRONT COVER).
- ◆ Remove the fuse block (1) from the clip (2).
- ◆ Unscrew and remove the screw (3).
- ◆ Remove the clip (2).
- ◆ Withdraw the battery case (4) together with the battery.

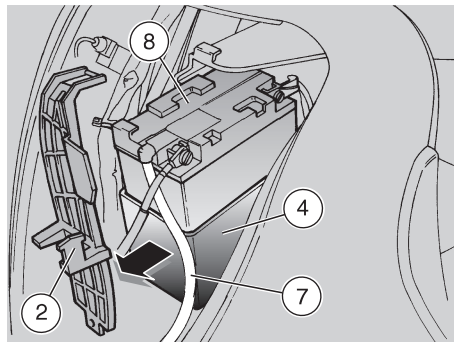

CHECKING AND CLEANING THE TERMINALS

- ◆ Extract the battery case, see beside (EXTRACTING THE BATTERY CASE).
- ◆ Make sure that the cable terminals (5) and the battery terminals (6) are:
 - in good conditions (and not corroded or covered with deposits);
 - covered with neutral grease or Vaseline.

If necessary:

- ◆ Disconnect first the negative (–) and then the positive cable (+).
- ◆ Brush with a wire brush to eliminate any sign of corrosion.
- ◆ Reconnect first the positive (+) and then the negative cable (–).
- ◆ Cover the terminals of the cables and of the battery with neutral grease or Vaseline.

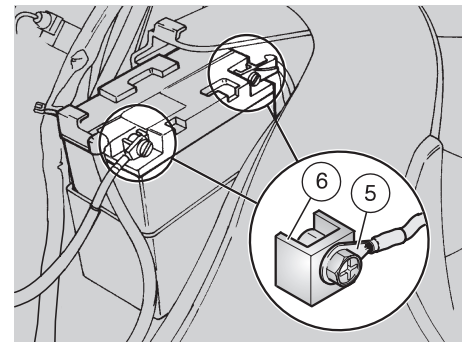

REMOVING THE BATTERY

- ◆ Extract the battery case, see beside (EXTRACTING THE BATTERY CASE)
- ◆ Disconnect first the negative (–) and then the positive cable (+).
- ◆ Remove the battery breather pipe (7).
- ◆ Remove the battery (8) from its compartment and put it on a flat surface, in a cool and dry place.

⚠ WARNING

Once it has been removed, the battery must be stored in a safe place and kept away from children.

- ◆ Put back the battery case, see beside (EXTRACTING THE BATTERY CASE).

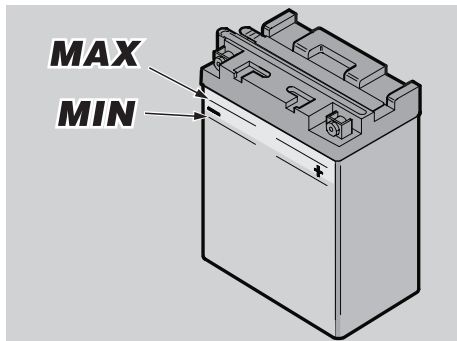

CHECKING THE ELECTROLYTE LEVEL

To check the electrolyte level, proceed as follows:

- ◆ Extract the battery case, see p. 53 (EXTRACTING THE BATTERY CASE).
- ◆ Make sure that the fluid level is included between the two “MIN” and “MAX” notches stamped on the battery side. Otherwise:
- ◆ Remove the element plugs.

⚠ CAUTION

Top up with distilled water only. Do not exceed the “MAX” mark, since the electrolyte level increases during the recharge.

- ◆ Top up by adding distilled water.

RECHARGING THE BATTERY

- ◆ Remove the battery, see p. 53 (REMOVING THE BATTERY).
- ◆ Remove the element plugs.
- ◆ Check the electrolyte level, see beside (CHECKING THE ELECTROLYTE LEVEL).
- ◆ Connect the battery with a battery charger.
- ◆ A recharge with an amperage equal to 1/10th of the battery capacity is recommended.
- ◆ After the recharging operation, check the electrolyte level again and if necessary top up with distilled water.
- ◆ Put back the element plugs.

⚠ CAUTION

Reassemble the battery only 5-10 minutes after disconnecting the recharger, since the battery continues to produce gas for a short lapse of time.

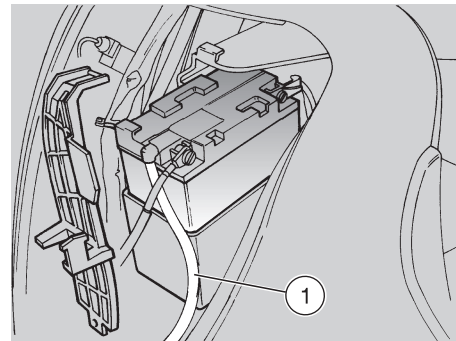

INSTALLING THE BATTERY

- ◆ Extract the battery case, see p. 53 (EXTRACTING THE BATTERY CASE).
- ◆ Put the battery in its container.
- ◆ Connect the battery breather pipe (1).

⚠ CAUTION

Always connect the battery breather pipe, to prevent the sulphuric acid vapours from corroding the electric system, painted parts, rubber elements or gaskets when they exit the breather pipe itself.

- ◆ Connect, in order, the positive (+) and negative (-) cable.
- ◆ Cover the terminals of the cables and of the battery with neutral grease or Vaseline.
- ◆ Put back the battery case, see p. 53 (EXTRACTING THE BATTERY CASE).

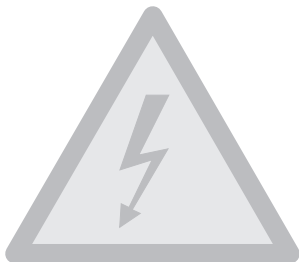

CHANGING THE FUSES

Carefully read p. 37 (MAINTENANCE).

CAUTION

Do not repair faulty fuses.

Never use fuses different from the recommended ones.

The use of unsuitable fuses may damage the electric system or, in case of short circuit, may even cause a fire.

NOTE If a fuse blows frequently, there probably is a short circuit or an overload in the electric system.

In this case it is advisable to consult an **aprilia** Official Dealer.

If an electric component does not work or works irregularly, or if the engine fails to start, it is necessary to check the fuses. Check the 7,5 A and the 15 A fuses first and then the 20A fuse.

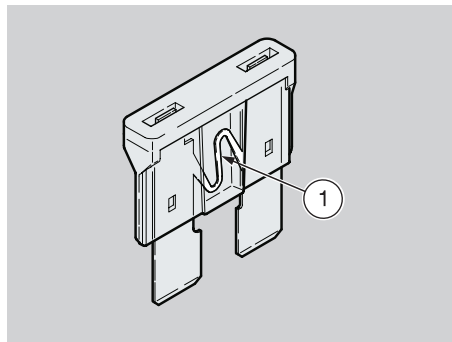

To carry out the checking:

- ◆ Remove the front cover, see see p. 48 (REMOVING THE FRONT COVER).
- ◆ Extract the fuses one by one and check if the filament (1) is broken.
- ◆ Before replacing a fuse, try to find out the cause of the trouble, if possible.
- ◆ Then replace the damaged fuse with a new one having the same amperage.

NOTE If you use one of the spare fuses, put a new fuse in the appropriate seat.

- ◆ Put back the front cover, see see p. 53 (EXTRACTING THE BATTERY CASE).

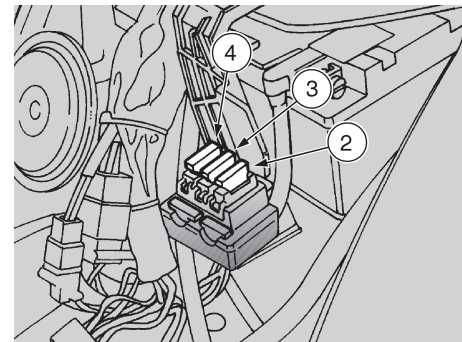

ARRANGEMENT OF THE FUSES

- **7,5A (2) fuse**
From the ignition switch to: ignition.
- **15A (3) fuse**
From the ignition switch to: all light loads and horn.
- **20A (4) fuse**
From the battery to: ignition switch, voltage regulator, electric fan.



CHECKING THE SWITCHES

The vehicle is provided with two switches:

- Stoplight switch on the rear brake control lever.
- Stoplight switch on the front brake control lever.

If you need assistance or technical advice, consult your **aprilia** Official Dealer, who can ensure you prompt and accurate servicing.

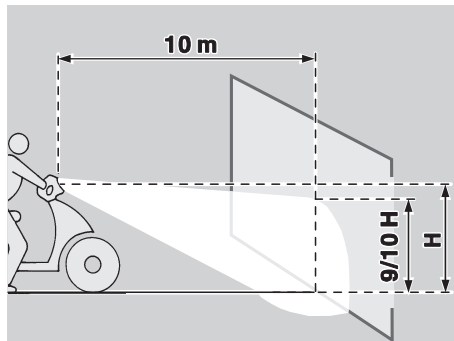

VERTICAL ADJUSTING OF THE HEADLIGHT BEAM

To rapidly check the correct direction of the beam, place the vehicle on flat ground, 10 m away from a wall.

Turn on the low beam, sit on the vehicle and make sure that the beam projected on the wall is slightly under the horizontal line of the headlight (about 9/10th of the total height).

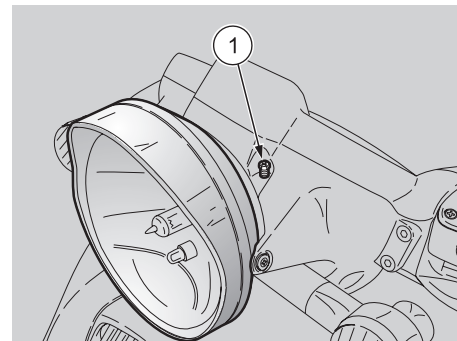

To adjust the headlight beam:

- ◆ Remove the front part of the fairing, see p. 49 (REMOVING THE FRONT PART OF THE FAIRING).
- ◆ Turn the appropriate screw (1) with a screwdriver.

By **TURNING IT CLOCKWISE**, you set the beam upwards.

By **TURNING IT ANTICLOCKWISE**, you set the beam downwards.

BULBS

Carefully read p. 37 (MAINTENANCE).

⚠ WARNING

Risk of fire.

Keep fuel and other flammable substances away from the electrical components.

⚠ CAUTION

Before changing a bulb, move the ignition switch to position “” and wait a few minutes, so that the bulb cools down.

Change the bulb wearing clean gloves or using a clean and dry cloth.

Do not leave fingerprints on the bulb, since these may cause its overheating and consequent breakage.

If you touch the bulb with bare hands, remove any fingerprint with alcohol, in order to avoid any damage.

DO NOT FORCE THE ELECTRIC CABLES.

NOTE Before changing a bulb, check the fuses, see p. 55 (CHANGING THE FUSES).

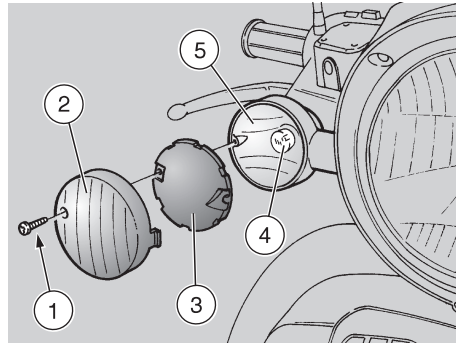

CHANGING THE DIRECTION INDICATOR BULBS

Carefully read beside (BULBS).

To change the bulbs:

NOTE The following information refers to one direction indicator only, but is valid for all of them.

- ◆ Unscrew and remove the screw (1).

⚠ CAUTION

Proceed with care.

Do not damage the tangs and/or their seats.

- ◆ Remove the protection screen (2).
- ◆ Remove the coloured screen (3).

- ◆ Press the bulb (4) slightly and rotate it anticlockwise.

NOTE If the bulb socket (5) goes out of its seat, reinsert it correctly, making the bulb socket opening coincide with the screw seat.

- ◆ Extract the bulb from its seat.

NOTE Insert the bulb in the bulb socket, making the two bulb pins coincide with the relevant guides on the socket.

- ◆ Correctly install a new bulb of the same type.

For the reassembly:

NOTE Upon reassembly, position the coloured screen (3) and the protection screen (2) correctly in their seats.

⚠ CAUTION

Tighten the screw (1) moderately and with great care, in order to avoid damaging the protection screen (2) and the coloured screen (3).

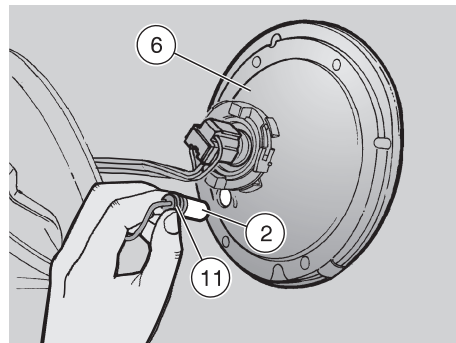
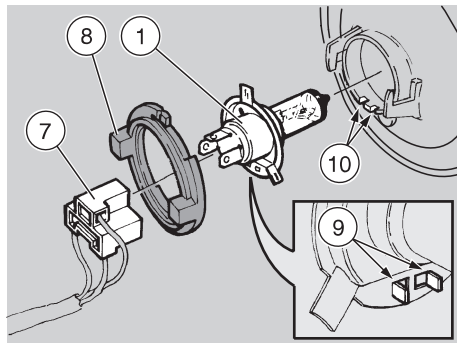
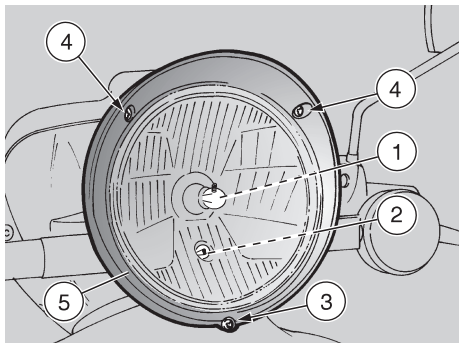

CHANGING THE HEADLIGHT BULBS

Carefully read p. 57 (BULBS).

The headlight contains:

- One low/high beam bulb (1).
- One parking light bulb (2).

To change the bulbs, proceed as follows:

- ◆ Unscrew and remove the screw (1).

NOTE Upon reassembly, take care not to invert the position of the screws (3) and (4).

- ◆ Unscrew and remove the screws (4).
- ◆ Remove the frame (5).
- ◆ Extract the parabolic reflector (6).

NOTE Upon reassembly, install the parabolic reflector (6) correctly, making the insertion seats coincide with the headlight body.

LOW/HIGH BEAM BULB (HALOGEN BULB)

⚠ CAUTION

To extract the bulb electric connector, do not pull its electric wires.

- ◆ Grasp the bulb electric connector (7), pull it and disconnect it from the bulb (1).
- ◆ Rotate the bulb socket (8) anticlockwise and extract it from the reflector.
- ◆ Extract the bulb (1).

For the reassembly:

NOTE Insert the bulb (1) in the reflector, by making the two elements (9) on the bulb coincide with the respective guides (10) on the reflector.

- ◆ Position the bulb socket (8) in the reflector and rotate it clockwise.
- ◆ Connect the bulb electric connector (7).

PARKING LIGHT BULBS

⚠ CAUTION

To extract the bulb socket, do not pull its electric wires.

- ◆ Grasp the bulb socket (11), pull it and take it out of its seat.
- ◆ Extract the parking light bulb (2) and replace it with a new one of the same type.

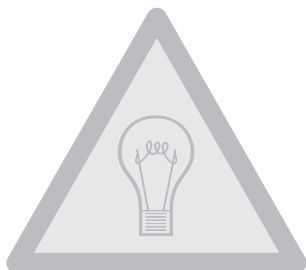

CHANGING THE REAR LIGHT BULB

Carefully read p. 57 (BULBS).

The rear light contains:

- A parking light/stoptight bulb (1).
- One number plate bulb (2).

To change them:

- ◆ Unscrew the screws (3).
- ◆ Remove the protection screen (4).

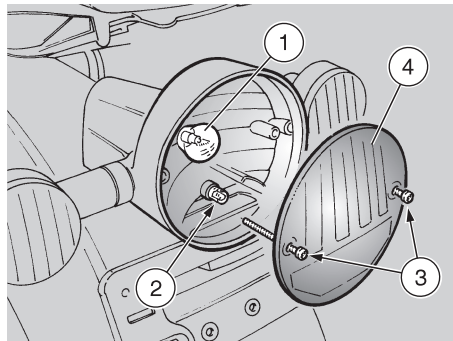

PARKING LIGHT/STOPLIGHT BULB

- ◆ Slightly press the bulb (1) and rotate it anticlockwise.
- ◆ Remove the bulb from its seat.

NOTE Insert the bulb in the socket, making the two bulb pins coincide with the relevant guides on the socket.

- ◆ Correctly install a new bulb of the same type.



NUMBER PLATE BULB

- ◆ Withdraw the bulb (2) and replace it with a new one of the same type.

NOTE Upon reassembly, correctly position the protection screen in its seat.

CAUTION

Tighten the screws (5) carefully, without exerting too much pressure, in order to avoid damaging the protection screen.

⚠ WARNING

Before transporting the vehicle, it is necessary to empty the fuel tank and the carburettor completely, see below (DRAINING THE FUEL TANK) making sure that both are completely dry.

During transport the vehicle must be kept in vertical position and be firmly anchored, in order to avoid any leakage of fuel, oil or coolant.

In case of failure, do not tow the vehicle, but ask for assistance.

DRAINING THE FUEL TANK

Carefully read p. 22 (FUEL).

⚠ WARNING

Risk of fire.
Wait until the engine and the exhaust silencer have completely cooled down. Fuel vapours are noxious for your health.

Before proceeding, make sure that the room in which you are working is properly ventilated.

Do not inhale fuel vapours.

Do not smoke, nor use free flames.

DO NOT DISPOSE OF FUEL IN THE ENVIRONMENT.

- ◆ Position the vehicle on the centre stand.
- ◆ Stop the engine and wait until it has cooled down.
- ◆ Prepare a container with capacity exceeding the fuel quantity present in the tank and put it on the ground on the left side of the vehicle.
- ◆ Remove the filler cap.
- ◆ Empty the fuel tank by means of a manual pump or a similar system.

⚠ WARNING

After draining the tank, tighten the filler cap.

To drain the carburettor completely, proceed as follows:

- ◆ Remove the central inspection cover, see p. 47 (REMOVING THE CENTRAL INSPECTION COVER).

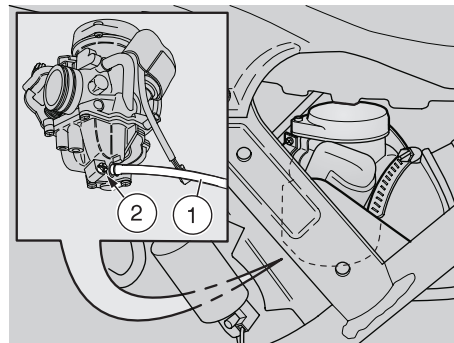

- ◆ Put the free end of the pipe (1) into a receptacle.
- ◆ Working on the front left side of the vehicle, open the carburettor outlet by loosening the drain screw (2) positioned under the float chamber.

When all the fuel has flowed out of the carburettor:

- ◆ Tighten the drain screw (2) completely.

⚠ CAUTION

Tighten the drain screw (2) with care, to avoid fuel leakages from the carburettor during the refuelling.

If necessary, contact an **aprilia Official Dealer.**



Clean the vehicle frequently if it used in particular areas or conditions, such as:

- ◆ Polluted areas (cities and industrial areas).
- ◆ Areas characterized by an high percentage of salinity and humidity (sea areas, hot and humid climates).
- ◆ Particular conditions (use of salt and anti-ice chemical products on the roads during the winter).
- ◆ Avoid leaving deposits of industrial and polluting powders, tar spots, dead insects, bird droppings, etc. on the body.
- ◆ Avoid parking the vehicle under trees, since in some seasons residues, resins, fruits or leaves fall down, which contain substances that may damage the paint.

⚠ WARNING

After the vehicle has been washed, its braking functions could be temporarily impaired because of the presence of water on the grip surfaces. Calculate long braking distances to avoid accidents. Brake repeatedly to restore normal conditions.

Carry out the preliminary checking operations, see p. 30 (PRELIMINARY CHECKING OPERATIONS).

To remove dirt and mud from the painted surfaces use a low- pressure water jet, carefully wet the dirty parts, remove mud and filth with a soft car sponge impregnated with a lot of water and shampoo (2 ÷ 4% parts of shampoo in water). Then rinse with plenty of water and dry with chamois leather.

To clean the outer parts of the engine use a degreaser, brushes and wipers.

⚠ CAUTION

To clean the lights, use a sponge soaked with water and a neutral detergent, rubbing the surfaces delicately and rinsing frequently with plenty of water.

⚠ CAUTION

Polish with silicone wax only after having carefully washed the vehicle.

Do not use polishing pastes on matt paints.

Do not wash the vehicle under the sun, especially during the summer, when the body is still warm, since if the shampoo dries before being rinsed away, it can damage the paint.

Do not use liquids at a temperature exceeding 40°C to clean the plastic components of the vehicle

Do not direct high-pressure water or air jets or steam jets on to the following components: wheel hubs, controls on the right and left side of the handlebar, bearings, brake pumps, instruments and indicators, exhaust pipes, glove/tool kit compartment, ignition switch/steering lock, radiator wings, fuel cap, lights and electric connections.

Do not use alcohol, petrol or solvents to clean the rubber and plastic parts and the saddle: use only water and mild soap.

⚠ WARNING

Do not apply protection waxes onto the saddle, in order not to make it too slippery.

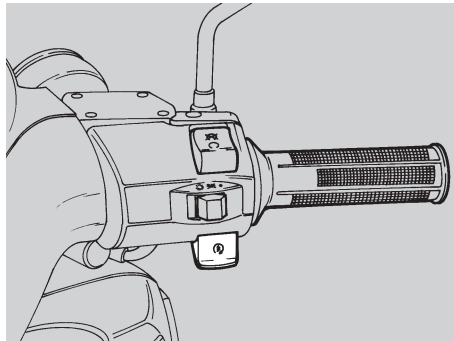
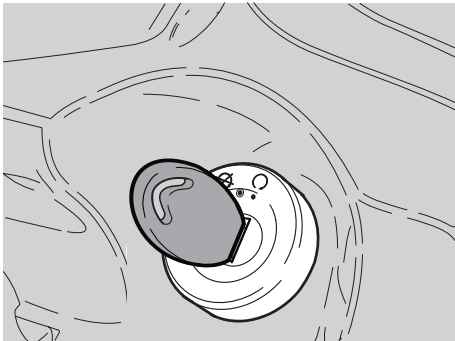

LONG PERIODS OF INACTIVITY

After a long period of inactivity of the vehicle some precautions are necessary to avoid any problem.

Further, it is important to carry out the necessary repairs and a general check up before the period of inactivity, since you could forget to carry them out later.

Proceed as follows:

- ◆ Empty the fuel tank and the carburettor, see p. 60 (DRAINING THE FUEL TANK).
- ◆ Remove the spark plug, see p. 51 (SPARK PLUG).
- ◆ Pour a teaspoon of engine oil (5-10 cm³) into the cylinder.

NOTE Put a clean cloth on the cylinder, near the spark plug seat, in order to protect it from oil sprays.

- ◆ Turn the ignition switch to position “O” and press the engine start push button “Ⓢ” for a few seconds, to distribute the oil evenly on the cylinder surfaces.
- ◆ Remove the cloth.
- ◆ Put back the spark plug.
- ◆ Remove the battery, see p. 53 (REMOVING THE BATTERY) and p. 52 (LONG INACTIVITY OF THE BATTERY).
- ◆ Wash and dry the vehicle, see p. 61 (CLEANING).
- ◆ Polish the painted surfaces with wax.
- ◆ Inflate the tyres, see p. 63 (TECHNICAL DATA).
- ◆ By means of a suitable support, position the vehicle so that both tyres are raised from the ground.
- ◆ Place the vehicle in an unheated, not-humid room, away from sunlight, with minimum temperature variations.

- ◆ Position and tie a plastic bag on the final pipe of the exhaust silencer, in order to prevent moisture from getting into it.
- ◆ Cover the vehicle avoiding the use of plastic or waterproof materials.

AFTER A PERIOD OF INACTIVITY

- ◆ Uncover and clean the vehicle, see p. 61 (CLEANING).
- ◆ Check the charge of the battery, see p. 54 (RECHARGING THE BATTERY) and install it, see p. 54 (INSTALLING THE BATTERY).
- ◆ Refuel, see p. 22 (FUEL).
- ◆ Carry out the preliminary checking operations, see p. 30 (PRELIMINARY CHECKING OPERATIONS).

WARNING

Have a test ride at moderate speed in a low-traffic area.

TECHNICAL DATA

DIMENSIONS	Max. length.....	2075 mm
	Max. width.....	900 mm
	Max. height (front part of the fairing included)...	1225 mm
	Seat height.....	800 mm
	Distance between centres.....	1380 mm
	Min. ground clearance.....	154 mm
	Weight ready for starting.....	148 kg
ENGINE	Model 125	120 S
	Model 150	154 S
	Model 200	177 S
	Type.....	one-cylinder, 4-stroke engine with overhead camshaft
	Number of valves.....	4
	Number of cylinders.....	1
	Total displacement 125	124,91 cm ³
	Total displacement 150	150,95 cm ³
	Total displacement 200	176,3 cm ³
	Bore / stroke 125	56,4 mm / 50,0 mm
	Bore / stroke 150	62,0 mm / 50,0 mm
	Bore / stroke 200	62,0 mm / 58,4 mm
	Compression ratio 125 150	12,5 ± 0,5 : 1
	Compression ratio 200	11,2 ± 0,5 : 1
	Starting.....	electric
Engine idling rpm.....	1600 ± 100 rpm	
Clutch.....	automatic, dry centrifugal clutch	
Change gear.....	automatic	
Lubrication system.....	wet sump lubrication, forced circulation with mechanical pump; oil level check by means of a graduated dipstick	
Cooling.....	liquid cooling, forced circulation with centrifugal pump	
CAPACITIES	Fuel (reserve included).....	9 ℓ
	Fuel reserve.....	2 ℓ
	Engine oil	
	- engine oil change only.....	1050 cm ³
	- engine oil and engine oil filter change.....	1100 cm ³
	- change for engine overhaul.....	1150 cm ³
	Transmission oil.....	110 cm ³
	Coolant.....	1,2 ℓ (50% water + 50% antifreeze with ethylene glycol)
	Front fork oil.....	130 cm ³ (for each rod)
	Seats.....	2
Vehicle max. load (driver + luggage).....	105 kg	
- (driver + passenger + luggage).....	180 kg	

TRANSMISSION	Speed change gear	automatic stepless
	Primary	V-belt
	Secondary	gears
	Total engine/wheel ratio 125	
	- minimum.....	26,88
	- maximum.....	8,06
	Total engine/wheel ratio 150	
	- minimum.....	25,98
	- maximum.....	7,57
TRANSMISSION	Total engine/wheel ratio 200	
	- minimum.....	30,63
	- maximum.....	8,89
CARBURETTOR	Model.....	KEIHIN CVK 26
	Choke tube	equivalent diameter 25 mm
FUEL SUPPLY	Type.....	vacuum pump
	Fuel	Leaded (4 Stars UK) or unleaded premium grade petrol according to the DIN 51600 standard, min. O.N. 95 (N.O.R.M.) and 85 (N.O.M.M.)
FRAME	Type.....	one beam at the front, split in two overlapping cradles at the rear, in steel tubes with high yield point
	Steering inclination angle	27°
	Fore stroke	85 mm
SUSPENSIONS	Front.....	hydraulically operated telescopic fork
	Stroke	110 mm
	Rear.....	hydraulic, double-effect shock absorber with preload adjustment
	Wheel stroke	105 mm
BRAKES	Front.....	disc brake - Ø 260 mm - with hydraulic transmission
	Rear.....	disc brake - Ø 220 mm - with hydraulic transmission
WHEEL RIMS	Type.....	in light alloy
	Front.....	2,50 x 16"
	Rear.....	3,00 x 16"

TYRES	Type	Tubeless
	Front.....	100 / 80 - 16" 50 P
	Rear	130 / 80 - 16" 64 P
STANDARD INFLATION PRESSURE		
	Front.....	190 kPa (1,9 bar)
	Rear	190 kPa (1,9 bar)
INFLATION PRESSURE WITH PASSENGER		
	Front.....	200 kPa (2,0 bar)
	Rear	220 kPa (2,2 bar)
IGNITION	Type	C.D.I. / Inductive
	Spark advance	8° ± 2° - before T.D.C. at 1600 rpm
SPARK PLUG	Standard.....	NGK CR8 E - NGK CR8 E VX
	Spark plug gap.....	0,6 – 0,7 mm
ELECTRIC SYSTEM	Battery.....	12 V - 12 Ah
	Fuses	20 - 15 - 7,5 A
	Generator (with permanent magnet)	12 V - 180 W
BULBS	Low/high beam.....	12 V - 65 W
	Front parking light	12 V - 3 W
	Direction indicators.....	12 V - 10 W
	Rear parking light/stoplight.....	12 V - 5/21 W
	Number plate.....	12 V - 5 W
	Dashboard lighting	12 V - 1,2 W
WARNING LIGHTS	Direction indicators.....	12 V - 2 W
	Engine oil pressure	12 V - 2 W
	Low beam.....	12 V - 2 W
	High beam.....	12 V - 2 W
	Low fuel.....	12 V - 2W

WIRING DIAGRAM KEY - Scarabeo 125 - Scarabeo 150 - Scarabeo 200

- 1) Generator
- 2) Ignition coil
- 3) Starter
- 4) Voltage regulator
- 5) Fuses
- 6) Battery
- 7) Start relay
- 8) Front stoplight switch
- 9) Rear stoplight switch
- 10) Coolant temperature thermistor
- 11) Engine oil pressure sensor
- 12) Right direction indicator warning light
- 13) Fuel level sensor
- 14) Rear left direction indicator
- 15) Rear light
- 16) Rear right direction indicator
- 17) Blinking
- 18) Ignition switch
- 19) Right dimmer switch
- 20) Left dimmer switch
- 21) Complete dashboard
- 22) Low beam warning light
- 23) Dashboard bulbs
- 24) Low fuel warning light
- 27) Coolant temperature instrument
- 28) High beam warning light
- 29) Left direction indicator warning light
- 30) Horn
- 31) Front right direction indicator
- 32) Low/high beam bulb
- 33) Front parking light
- 34) Front left direction indicator
- 35) Engine oil pressure warning light
- 36) Multiple connectors
- 37) Spark plug
- 38) Automatic starter
- 39) Complete headlight
- 40) Fuel level indicator
- 41) Fan
- 42) CDI
- 43) Thermal switch
- 44) Pick up
- 45) Number plate light
- 46) STARTER thermometric switch
- 47) Heating device for the cold start of the engine



CABLE COLOURS

- | | |
|-----------|------------|
| Ar | orange |
| Az | light blue |
| B | blue |
| Bl | white |
| G | yellow |
| Gr | gray |
| M | brown |
| N | black |
| R | red |
| V | green |
| Vi | violet |
| Ro | pink |

LUBRICANT CHART

Engine oil (recommended):  SUPERBIKE 4, SAE 5W - 40 or  Agip 4T FORMULA RACING, SAE 5W - 40.





As an alternative to the recommended oil, it is possible to use high-quality oils with characteristics in compliance with or superior to the CCMC G-4, A.P.I. SG. specifications.

Transmission oil (recommended):  F.C., SAE 75W - 90 or  Agip GEAR SYNTH, SAE 75W - 90.

As an alternative to the recommended oil, it is possible to use high-quality oils with characteristics in compliance with or superior to the A.P.I. GL4 specifications.



Fork oil (recommended):  F.A. 5W or  F.A. 20W fork oil;

as an alternative  Agip FORK 5W or  Agip FORK 20W.

If you need an oil with intermediate characteristics in comparison with the  F.A. 5W and  F.A. 20W or  Agip FORK 5W and  Agip FORK 20W, these can be mixed as indicated below:

SAE 10W =  F.A. 5W 67% of the volume, +  F.A. 20W 33% of the volume or
 Agip FORK 5W 67% of the volume +  Agip FORK 20W 33% of the volume.

SAE 15W =  F.A. 5W 33% of the volume, +  F.A. 20W 67% of the volume or
 Agip FORK 5W 33% of the volume +  Agip FORK 20W 67% of the volume.

Bearings and other lubrication points (recommended):  BIMOL GREASE 481 or  Agip GREASE SM 2.

As an alternative to the recommended product, use high-quality grease for rolling bearings, working temperature range -30°C.... +140°C, dripping point 150°C... 230°C, high protection against corrosion, good resistance to water and oxidation.

Protection of the battery poles: neutral grease or vaseline.

Spray grease for chains (recommended):  CHAIN SPRAY or  Agip CHAIN LUBE.

WARNING

Use new brake fluid only.

Brake fluid (recommended):  F.F., DOT 5 (DOT 4 compatible) or  Agip BRAKE 5.1, DOT 5 (compatible DOT 4).

WARNING

Use only antifreeze and anticorrosive without nitrite, ensuring protection at -35°C at least.

Engine coolant (recommended):  ECOBLU -40°C or  Agip COOL.

NOTE

aprilia

ASK FOR GENUINE SPARE PARTS ONLY

- 
- I APRILIA s.p.a.** via G. Galilei, 1 - 30033 Noale (VE) Italy
 Tel. +39(0)41 5829111 - Fax +39(0)41 441054 - Servizio Clienti **aprilia** +39(0)41 5786269
 - F APRILIA WORLD SERVICE B.V.** Z.A. Central Parc - 255 BLD Robert Ballanger
 B.P. 77- 93421 Villepinte (F) - Tel. (0) 149634747 - Fax (0) 149638750
 - D MOTORRAD GmbH** Am Seestern 3 D-40547 Düsseldorf (D)
 Tel. (211) 59018-00 - Fax (211) 5901819
 - E APRILIA WORLD SERVICE B.V. ESPAÑA** Calle Alcorcon 19 - 28850 Torrejón de Ardoz - Madrid (E)
 Tel. (91) 6778083 - Fax (91) 6778577
 - NL APRILIA NEDERLAND** Nikkelstraat 1 - 4823 AE Breda (NL)
 Tel. (076) 5431640 - Fax (076) 5431649
 - UK APRILIA MOTO U.K. LTD.** Dunragit - Stranraer - Wigtownshire DG9 8PN - Scotland (UK)
 Tel. (01776) 888670 - Fax (01581) 400661
 - USA APRILIA USA Inc.** 110 Londonderry Court, Suite 130 - Woodstock, GA 30188 (USA)
 Tel. 770 592 2261 - Fax 770 592 4878
 - A GINZINGER IMPORT GmbH & CO** Frankenburgerstrasse 19 - 4910 Fied im Innkreis (A)
 Tel. (7752) 88077 - Fax (7752) 70684
 - P MILFA IMPORTAÇÃO EXPORTAÇÃO LDA.** Avenida da Republica 692 - 4450-238 Matosinhos (P)
 Tel. 229382450 - Fax 229371305
 - SF TUONTI NAKKILA OY** P.o.B. 18 - 29250 Nakkila (SF)
 Puh. (02) 5352500 - Fax (02) 5372793
 - B RAD n.v. / s.a.** Industriegebied - Landegemstraat 4 - B - 9031 Drogen-Baarle
 Tel. (09) 2829410 - Fax (09) 2829433
 - GR MOBILITY S.A.** av. Messogion 191 - 11525 Athens (GR)
 Tel. (1) 6728705 - Fax (1) 6728727
 - GR MOBILITY A.E.** Λ. Μεσογειων 191 - 115-25 Αθηνα - Ελλαδα
 Τηλ. (1) 6728705 - Φαξ: (1) 6728727
 - CH MOHAG AG** Bernerstrasse Nord 202 - 8064 Zurich (CH)
 Tel. (1) 4348686 - Fax (1) 4348606
 - DK S T.M.P.** Islandsvej 3 - 7900 Nykøbing Mors (DK)
 Tel 97722233 - Fax 97722133 - E-mail: t_m_p@post4.tele.dk
 - J BOSCO MOTO CO. LTD.** 22-25 Hakunoshima 2 Chome Minoo-Shi 562 Osaka
 562-0012 OSAKA (J) - Tel. (0727) 253311 - Fax (0727) 253322
 〒 562-0012 大阪府箕面市白島 2 丁目 22-25
 電話 : (0727)25-3311 - FAX : (0727)25-3322
 - J 株式会社 ボスコ・モト**
 - SGP IDEAL MOTOR SPORT PTE. LTD.** 20 Mactaggart Road, #01-01 Khong Guan Industrial Building 368079 Singapore (SGP)
 Tel. 2820082 - Fax 2821012

PL MOTO SP. ZOO	Ul. Trakt Lubelski 298 B - 04-667 Warszawa (PL) Tel. (22) 121183 - Fax (22) 121183
IL AVIRAM & GOLDMAN IMPORT & MARKETING CO. LTD.	21, Tushia Street - P.O. BOX 57266 - 61572 - Israel - Tel-Aviv (IL) Tel. (3) 5623951 - Fax (3) 5623950
ROK BIKE KOREA CO., LTD.	YeungSoo BLDG 302 #206-25, Ohjang-dong, Chung-ku, Seoul (ROK) Tel. (02) 2275-6130/1 - Fax. (02) 2275-6132
MAL GENTALI MALAYSIA SDN BHD	Unit B-1-8 Megan Phileo Promenade 189 Jalan Tun Razak - 50400 - Kuala Lumpur (MAL) Tel.(603) 21649800 Fax. (603) 21649700
RCH HARLEY DAVIDSON SANTIAGO	Isidora Goyenechea 2926 - Santiago (RCH) Tel. (2) 2321667 - Fax (2) 2321894
BM EVE'S CYCLES LTD.	114, Middle Road - PG BX Paget (BM) Tel. (441) 2366247 - Fax (441) 2366996
BR APRILIA-BRASIL	Av. Europa, 352 - Jardim Europa - 01449-001 Sao Paulo-SP (BR) Tel. (11) 30691220 Fax. (11) 30691221
AUS JOHN SAMPLE GROUP PTY LTD.	8, Sheridan Close - NSW 2214 - Milperra - Sydney (AUS) Tel. (2) 97722666 - Fax (2) 97742321
RSA MOTOVELO S.A.	Old Pretoria Road - Wynberg - Johannesburg (RSA) Tel. (11) 7868486 - Fax (11) 7868482
NZ MOTORCYCLING DOWNUNDER LTD.	35, Manchester Street - P.o.B. 22416 - Christchurch (NZ) Tel. (3) 3660129 - Fax (3) 3667580
HR ING-KART, d.o.o.	Miroslava Magdalenica, 1 - 10000 Zagreb (HR) Tel. (1) 3491107 / 3491091 - Fax (1) 3491555
SLO AVTO TRIGLAV, d.o.o.	Baragova 5 - 1113 Ljubljana (SLO) Tel. (61) 1883420 - Fax (61) 1883465
M BIKES & COMPANY LTD.	178, Marina Street, Pieta. MSD 08. (M) - Tel. (+356) 236 665 - Fax (+356) 239 368
TR METRO MOTORLU ARACLAR TICARET A.S.	Mihrabat Caddesi Akbeysoyak Yetimoglu Is Merkezi - 81640 - Kavacik-Istanbul (TR) - Tel. (0216) 4251565 - Fax (0216) 3312606
CZ A. SPIRIT A.S.	Cernokostelecka 116 - 10000 Praha 10 (CZ) Tel. (02) 703049 - Fax. (02) 703158
IRL K.D.I. KAWASAKI DISTRIBUTOR IRL. LTD.	17 Wood Street - Dublin 8 (IRL) Tel. (1) 4756046 Fax. (1) 4756461
N MC TEMA A.S.	Kjørbekkdalen 6,3735 Skien, Norway (N) Tel. 35506780 Fax. 35506781

aprilia s.p.a. wishes to thank its customers for the purchase of this vehicle.

- Do not dispose of oil, fuel, polluting substances and components in the environment.
- Do not keep the engine running if it isn't necessary.
- Avoid disturbing noises.
- Respect nature.