

aprilia

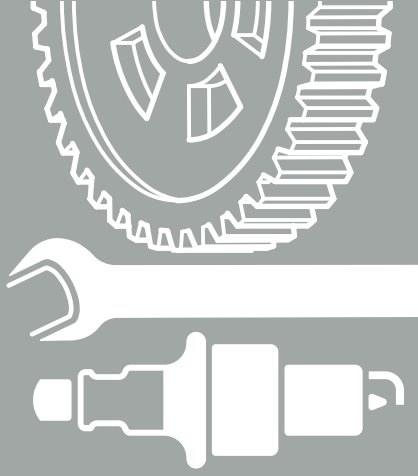

Service and repair manual

aprilia part # 8140222

SR 50 **USA**

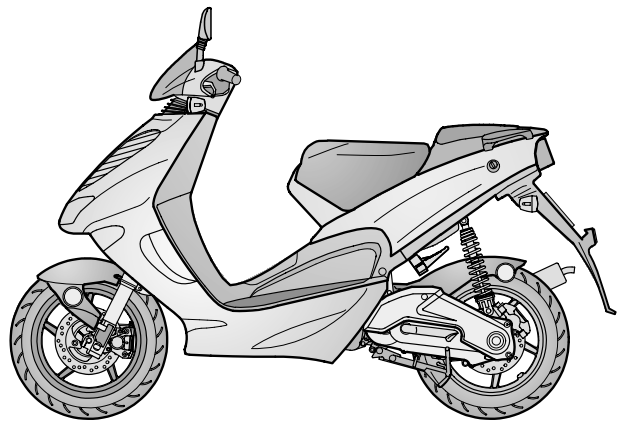

964X

FOREWORD



- This manual contains information covering normal servicing procedures.
- The information and illustrations contained in this manual are current as of the manual's publication. Since **aprilia s.p.a.** strives to always improve the quality and usefulness of its vehicles, changes may be made to the vehicles at any time. Thus, it is imperative that users of this manual understand that some information may be out of date for some vehicles. Be sure that the information in this manual applies to the vehicle that you are servicing before you begin any service operations.
- This publication is intended for **aprilia** dealers and their trained and qualified mechanics. The description of many service and repair operations is intentionally omitted, as it is assumed that the users of this manual have basic mechanical training, basic knowledge of the procedures regarding motor vehicle repair, and have available to them all current information published by **aprilia** concerning the vehicle. Without these things, the repair or servicing of the vehicle could be affected and could lead to a dangerous condition or accident for the servicing mechanic or the operator.

This manual does not describe all of the procedures necessary to repair and service the vehicle in detail. Therefore, it is important to be particularly careful in order to avoid any damage to the vehicle, its parts, or to cause injury to the mechanic or the rider.

Changes in the technical specifications and servicing procedures that become necessary as a result of changes to **aprilia** vehicles will be documented and distributed to all **aprilia** dealers. Therefore, it is necessary that the latest **aprilia** information be kept available to the servicing mechanics.

If you have questions regarding repair and servicing procedures, contact the **aprilia** Consumer Service (A.C.S.). A.C.S. technical counselors will be able to assist you with any problems that you might face.

For further information refer to:

- ENGINE SERVICE AND REPAIR MANUAL # 921 (I-UK-F-D-E);
- ENGINE SPARE PARTS CATALOGUE # 715;
- ENGINE SPARE PARTS CATALOGUE  # 716;
- "CHASSIS PARTS" SPARE PARTS CATALOGUE # 515V.
- "CHASSIS PARTS" SPARE PARTS CATALOGUE  # 516V.

aprilia s.p.a. reserves the right to modify any of its models in any manner at any time.

This manual is protected by copyright in all countries. Reproduction by any means, print or electronic, is prohibited. The mention of products or services supplied by entities other than **aprilia** is made for information purposes only. **aprilia** is not responsible for the performance or use of any product not specifically recommended or endorsed by **aprilia**.

First edition: july 1999

Second edition:

Reprint: june 2000

Produced and printed by:
stp editing division
 Soave (VERONA) - Italy
 Tel. +39 - 045 76 11 911
 Fax +39 - 045 76 12 241
 E-mail: customer@stp.it
 www.stp.it

On behalf of:
aprilia Consumer Service s.p.a.
 via Noalese, 156 - 30036 Santa Maria di Sala (VE) - Italia
 Tel. +39 - 041 57 86 101
 Fax +39 - 041 57 86 100
 www.aprilia.com

INTRODUCTION

This manual is divided into sections, chapters and paragraphs, by subject. The procedures described are laid out in single operation, and each operation is indicated by a .

The numbered parts shown in the figures are identified in the text with the number in parentheses or with the symbol representing them.

Example: (the following text is generic and does not refer to this specific vehicle):

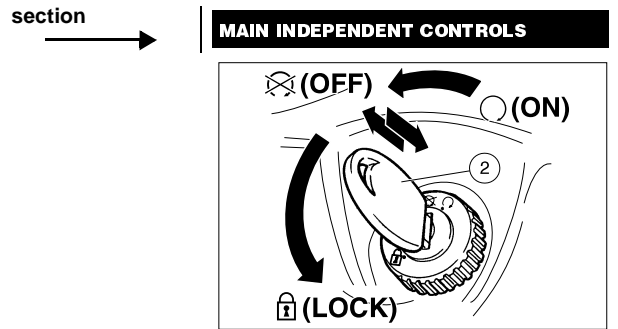

chapter → **STEERING LOCK**

safety warning → **⚠ WARNING**
 Never turn the key to position "⏏" while the vehicle is being operated. If you do so, you will lose control of the vehicle, and a crash will ensue.

paragraph → **OPERATION**
 To lock the steering:

- ◆ Turn the handlebar completely to the left.
- ◆ Turn the key (2) to position "⏏" (OFF) and press it.
- ◆ Release the key and rotate it to position "⏏" (LOCK).
- ◆ Remove the key.

SAFETY WARNINGS

Throughout this manual, you will see the following symbols:

⚠ WARNING

When you find this symbol on the vehicle or in the vehicle, this indicates that a potential for serious personal injury or death exists. Failure to follow this warning may result in serious risk of personal injury or death, of the mechanic working on the vehicle, the operator of the vehicle, or the general public. It also indicates that serious and permanent damage to the vehicle is possible.

⚠ CAUTION

This statement indicates a potential hazard which may result in some personal injury, or damage to the vehicle.

NOTE The word "NOTE" in this manual precedes important information or instructions to which special attention must be given.

GENERAL SAFETY RULES

CARBON MONOXIDE

If it is necessary to let the engine run in order to carry out some work, make sure that the area in which you are operating is properly ventilated. Never run the engine in enclosed spaces.

If it is necessary to work indoors, use an exhaust evacuation system.

⚠ WARNING

The exhaust fumes contain carbon monoxide, a poisonous gas that can cause loss of consciousness and even death.

Run the engine in an open area or, if it is necessary to work indoors, use an exhaust evacuation system.

GASOLINE

Work in a well ventilated area. Keep cigarettes, flames or sparks away from the work area and from the place where gasoline is stored.

⚠ WARNING

Gasoline is extremely flammable and becomes explosive under certain conditions.

KEEP AWAY FROM CHILDREN.

HOT COMPONENTS

⚠ WARNING

The engine and the components of the exhaust system become very hot and remain hot for some time after the engine has been stopped. Before handling these components, wear insulating gloves or wait until the engine and the exhaust system have cooled down.

USED ENGINE OIL

⚠ WARNING

Use latex gloves for the maintenance operations that require contact with used oil. Used engine oil may cause skin cancer if repeatedly left in contact with the skin for prolonged periods. Although this is unlikely unless you handle used oil on a daily basis, it is advisable to thoroughly wash your hands with soap and water after handling used oil.

KEEP AWAY FROM CHILDREN.

BRAKE FLUID

⚠ CAUTION

The brake fluid can damage painted, plastic or rubber parts. When performing maintenance operations on the braking system, put a clean shop towel on these parts.

Always wear goggles when servicing the brake system with brake fluid. Brake fluid is extremely destructive to your eyes. If you should accidentally get brake fluid in your eyes, flush immediately with a large quantity of cool clear water and seek professional medical assistance immediately.

KEEP AWAY FROM CHILDREN.

COOLANT

In certain conditions, the ethylene glycol contained in the engine coolant is flammable: its flame is invisible, but you can be burned anyway.

⚠ WARNING

Avoid spilling the engine coolant on the exhaust system or on the engine components. They may be hot enough to cause the coolant to ignite and burn without a visible flame.

The coolant (ethylene glycol) can cause skin irritation and is poisonous if swallowed.

Engine coolant is extremely attractive to animals and pets, as well as being extremely toxic to them. Do not leave coolant in an open container where animals may be able to drink it.

KEEP AWAY FROM CHILDREN.

Do not remove the radiator cap when the engine is hot. The coolant is under pressure and may cause burns.

BATTERY HYDROGEN GAS AND ELECTROLYTE

⚠ WARNING

The battery gives off explosive gases; keep cigarettes, flames and sparks away from the battery. Provide adequate ventilation when operating or recharging the battery.

The battery contains sulphuric acid (electrolyte). Contact with the skin or the eyes may cause serious burns.

Always wear tight fitting goggles and protective clothing when handling battery electrolyte. It is particularly important for you to protect your eyes, since even a minuscule amount of battery acid can destroy your vision. Should you accidentally get even the smallest amount of battery acid on your skin or eyes, immediately flush with large quantities of clear cool water and immediately seek professional medical attention.

The electrolyte is poisonous.

If the electrolyte is accidentally swallowed, drink large quantities of water or milk and then milk of magnesia or vegetable oil. Seek professional medical attention immediately.

KEEP AWAY FROM CHILDREN.

PRECAUTIONS AND GENERAL INFORMATIONS

Follow with care these recommendations when repairing, disassembling and reassembling the vehicle.

WARNING

The use of naked flames is forbidden for any type of operation.

Before commencing any service or inspection operation on the vehicle, switch off the engine and remove the key, wait until the engine and the exhaust system have cooled down and, if possible, raise the vehicle with the suitable equipment onto firm flat ground.

The brakes also get quite hot in operation. Be sure that the brakes have cooled thoroughly before beginning any service operations.

In order to avoid burns, be careful not to touch any parts of the engine or exhaust systems which have not cooled down completely.

Avoid the temptation to hold any hardware or other part of the vehicle in your mouth while working on the motorscooter.

No part of the motorscooter is edible and some of the coatings, plastics, and platings, etc. are noxious if not outright toxic.

If not expressly described, the reassembly of the units is carried out by reversing the order of operations.

Handle fuel with the greatest caution. See gasoline warning above.

Never use fuel as a solvent for cleaning the vehicle.

Disconnect the negative cable (-) from the battery when electric welding.

When two or more persons are working together, make sure that each is working in safe conditions.

Be sure that all the mechanics working on any one vehicle are thoroughly briefed as what each will be doing, and insure that one mechanic is responsible for insuring that all safety related items, such as tightening torques, are properly considered.

BEFORE DISASSEMBLY

- Remove any dirt, mud, dust and foreign matters from the vehicle before disassembling the components.
- Use, when necessary, the special tools designed for this vehicle.

DISASSEMBLING THE COMPONENTS

- Before disconnecting the joints (pipes, cables, etc.), mark the positions on all of them and mark them with different distinguishing signs.
Each piece must be marked clearly, in order not to have problems during installation.
- Clean and wash carefully any disassembled parts with low inflammability detergents.
- Keep the parts that are used in pairs together, since they have adapted to each other following the normal wear. Some components must be used together or replaced completely.
- Keep away from heat sources.

REASSEMBLING THE COMPONENTS

CAUTION

Never use a circlip twice. When a circlip is removed, it must be replaced with a new one.

When assembling a new circlip be careful not to stretch its ends more than strictly necessary to put it on the shaft.

After installing a circlip, make sure that it is completely and firmly inserted in its seat.

Do not use compressed air to clean the bearings.

NOTE The bearings must rotate freely, without halting or noise otherwise they must be replaced.

- Use only original **aprilia** SPARE PARTS.
- Use the recommended lubricants.
- Always lubricate parts before reassembly.
- When tightening screws, nuts, and bolts, start with the largest diameter fasteners. When several fasteners are arranged in a pattern, start with the innermost fasteners, and tighten diagonally across the pattern. Tighten each fastener successively before applying the final tightening torque.
- Always replace gaskets, grommets, circlips, O-rings and split pins (cotter pins) with new ones.
Before assembling, clean all mating surfaces carefully, removing all traces of the old gasket and gasket sealing compound. Also carefully clean any oil seal you plan to reuse. It is recommended that all oil seals be replaced each time they are disassembled. Gaskets should never be reused.
Apply a thin film of lithium based grease to all oil seals before assembling.
Install oil seals and bearings with the identification mark or serial number facing outward (visible).
Copiously lubricate bearings before installation and before assembly.
- Make sure that each component has been reassembled correctly.
- After any repair or periodic maintenance operation is carried out, the vehicle must be test ridden in an area away from traffic and other hazards.

HOW TO USE YOUR SERVICE AND REPAIR MANUAL

ADVICE FOR CONSULTATION

- This manual is divided into chapters, each one of which corresponds to a category of main components. To consult them, see the general index, p. 8 (TABLE OF CONTENTS).
- If not expressly indicated otherwise, for the reassembly of the units repeat the disassembly operations in reverse order.
- The terms "right" and "left" are referred to the rider seated on the vehicle in the normal riding position.
- For normal maintenance operations and for the use of the vehicle, consult the "USE AND MAINTENANCE" manual.

★ The operations preceded by this symbol must be repeated on the opposite side of the vehicle.



NOTE When asking your Dealer for spare parts, specify the spare parts code indicated on the SPARE PARTS IDENTIFICATION LABEL.

Write down the identification code in the space here below, in order to remember it also in case of loss or deterioration of the label.

The label is stuck on the right beam of the frame; to be able to read it, remove the right inspection cover, see p. 20 (REMOVING THE RIGHT AND LEFT INSPECTION COVERS).

aprilia N°		YEAR		T	V	W	X	Y	
SPARE PARTS CODE NUMBER		I.M.		A	B	C	D	E	
I	UK	A	P	SF	B	D	F	E	GR
NL	CH	DK	J	SGP	PL	IL	ROK	MAL	RCH
BM	USA	AUS	BR	RSA	NZ	CDN	HR	SLO	

In this manual the various versions are indicated by the following symbols:

-  **OPT** optional
-  liquid-cooled version
-  drum brake version

VERSION:

- | | |
|--|---|
|  I Italy |  PL Poland |
|  UK United Kingdom |  IL Israel |
|  A Austria |  ROK South Korea |
|  P Portugal |  MAL Malaysia |
|  SF Finland |  RCH Chile |
|  B Belgium |  BM Bermuda |
|  D Germany |  USA United States of America |
|  F France |  AUS Australia |
|  E Spain |  BR Brazil |
|  GR Greece |  RSA South Africa |
|  NL Holland |  NZ New Zealand |
|  CH Switzerland |  CDN Canada |
|  DK Denmark |  HR Croatia |
|  J Japan |  SLO Slovenia |
|  SGP Singapore | |

ELECTRICAL CONNECTORS

The electrical connectors must be disconnected as follows. Failure to follow these procedures will irreparably damage the connector and wiring.

- ◆ Press in the click tab.

⚠ CAUTION

Do not pull the cables to disconnect the two connectors.

- ◆ Grasp the two connectors and disconnect them by pulling in opposite directions.
- ◆ If dirt, rust, dust, or moisture is seen on the connector, blow out the connector with air.
- ◆ Make sure that the cables are correctly crimped to the terminals positioned inside the connectors.

NOTE The two halves of the connector fit together properly in only one orientation. Ensure that the connector is properly aligned before attempting to assemble it.

- ◆ Press the connectors firmly together, listening for the typical “click” sound for those connectors provided with a click tab. Ensure that both halves of the connectors are firmly pressed together.

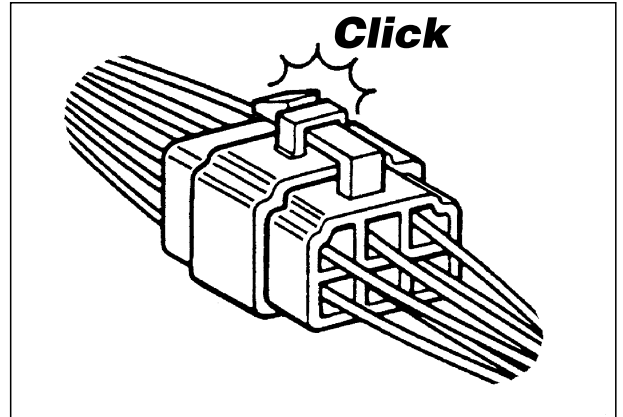

TIGHTENING TORQUES

The table below shows tightening torques for screws and bolts with metric ISO threads, as is used in this vehicle. These are general values to be used if no specific value is given in this manual or other **aprilia** service literature.

Screw or bolt thread	Spanner	Tightening torque	
		ftlb	(Nm)
M 6	10	4.34	6
M 8	12	10.84	15
M 10	14	21.70	30
M 12	17	39.79	55
M 14	19	61.49	85
M 16	22	94.03	130

For specific fasteners, see p. 11 (TIGHTENING TORQUES). If not otherwise indicated, the tightening torques shown should be used for clean and dry threads, at room temperature

NOTE To avoid damage to the threads, tighten screws and bolts as follows:

- ◆ Run up the fasteners finger tight.
- ◆ Applying half the prescribed tightening torque, tighten the fasteners that are diametrically opposite each other: (A) and (B); (C) and (D).
- ◆ Repeat, applying the prescribed tightening torque.

NOTE In this way the pressure exerted by the fastening elements will be uniformly distributed on the joint surface.

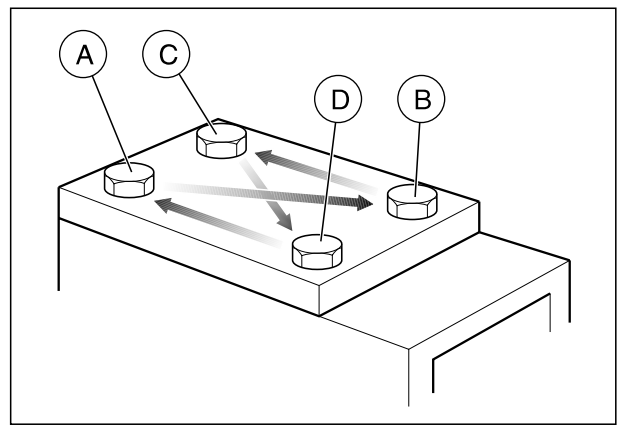



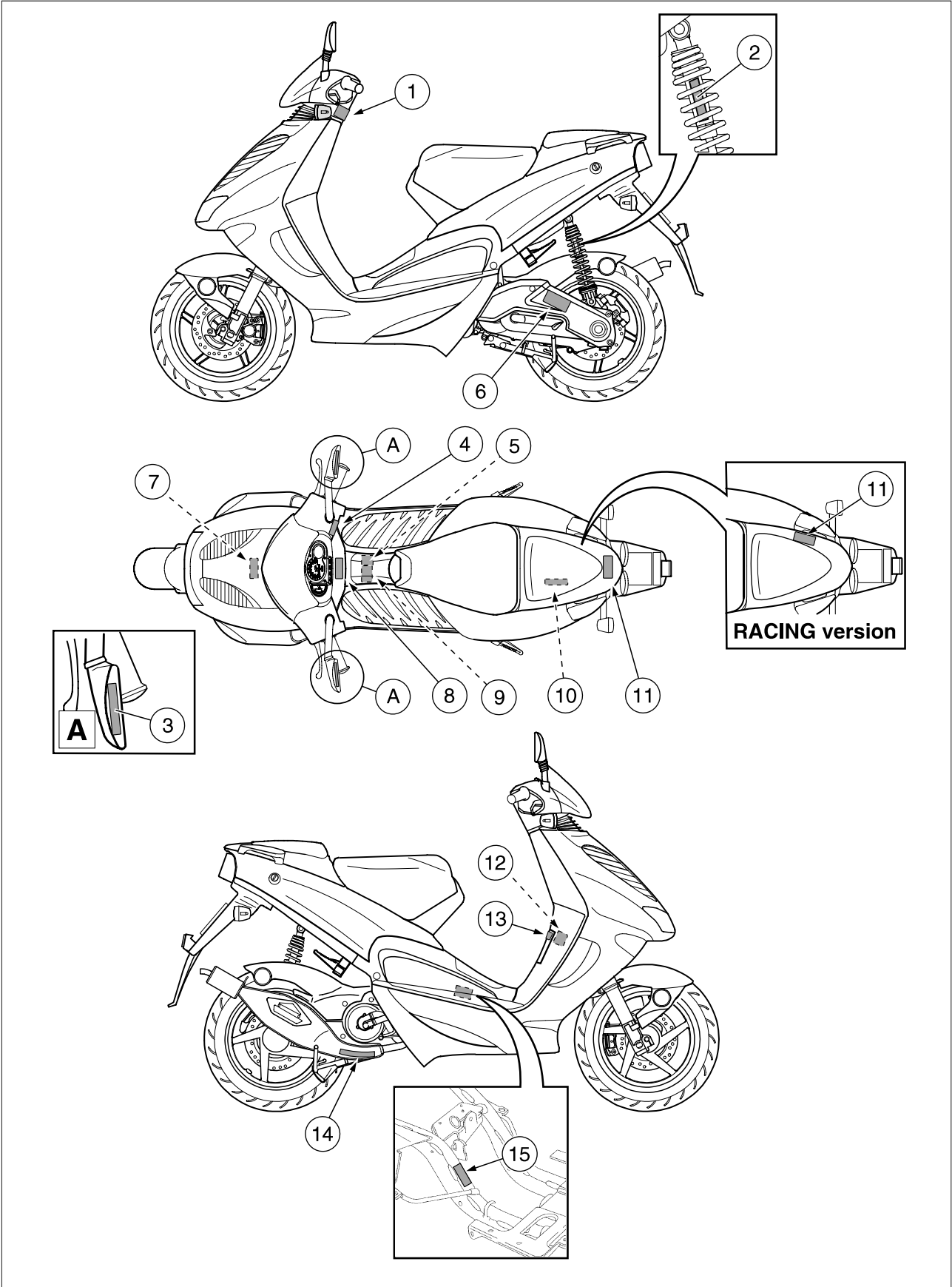















POSITION OF THE WARNING ADHESIVE LABELS



Ref.	Description																																
1	<p>⚠ WARNING!</p> <ul style="list-style-type: none"> •Wear a helmet, eye protection, and bright protective clothing. •Don't ride after consuming alcohol or other drugs. •Slow down on slippery surface, unfamiliar terrain or when visibility is reduced. •Read owner's manual carefully. •Failure to follow these warnings can lead to an accident and serious injuries or death. •USE UNLEADED FUEL RON min 95. •See owner's manual for the correct running in and maintenance of the vehicle. 																																
2	<p>⚠ WARNING!</p> <ul style="list-style-type: none"> •CONTAINS HIGH PRESSURE NITROGEN GAS. •SEE WORKSHOP MANUAL FOR DISPOSAL AND ADJUSTING UNIT. •DO NOT OPEN. DO NOT INCINERATE. INCINERATION, PUNCTURE OR DISASSEMBLY MAY CAUSE THIS UNIT TO EXPLODE. 																																
3	<p>OBJECTS IN MIRROR ARE CLOSER THAN THEY APPEAR.</p>																																
4	<p>ATTENTION! STARTING PROCEDURE</p> <p>With COLD engine set on CHOKE, brakes and push START button without opening throttle.</p> <p>With WARM engine set on brakes and push START button,</p>																																
5	<p>aprilia BATTERY SERVICE</p> <p>⚠ WARNING!</p>  <p>Maintain electrolyte level between the two level marks. Use only distilled water. Always keep the battery charged. Never disconnect the battery or regulator with the engine running. This will destroy the entire electrical system.</p>																																
6	<p>⚠ WARNING!</p> <p>Do not use any tire other than those recommended and approved by Aprilia. Maintain proper tire inflation. So not use any tire with less than 1/8" (3mm) tread remaining. Do not repair any tire, nor use a repaired tire. Do not ride your motorcycle overloaded or with an unbalanced load. Failure to follow these warnings can lead to an accident and serious injuries or death. See owner's manual.</p> <table border="1"> <thead> <tr> <th colspan="2">Tires pressure bar (psi)</th> <th colspan="2">Front tire</th> </tr> <tr> <th>Front tire</th> <th>Rear tire</th> <th colspan="2">Eurosawatech; Dunlop</th> </tr> </thead> <tbody> <tr> <td>1,7 (24,65)</td> <td>1,9 (25,55)</td> <td colspan="2">Pirelli Metzeler; Michelin { 130/60 - 13" 53J</td> </tr> <tr> <td>1,7 (24,65)</td> <td>2,1 (30,45)</td> <td colspan="2">Bridgestone; Cheng Shin</td> </tr> <tr> <th colspan="2">Tires pressure bar (psi)</th> <th colspan="2">Rear tire</th> </tr> <tr> <th>Front tire</th> <th>Rear tire</th> <th colspan="2">Eurosawatech; Dunlop</th> </tr> <tr> <td>1,7 (24,65)</td> <td>2,1 (30,45)</td> <td colspan="2">Pirelli Metzeler; Michelin { 130/60 - 13" 53J</td> </tr> <tr> <td>1,7 (24,65)</td> <td>2,1 (30,45)</td> <td colspan="2">Bridgestone; Cheng Shin</td> </tr> </tbody> </table>	Tires pressure bar (psi)		Front tire		Front tire	Rear tire	Eurosawatech; Dunlop		1,7 (24,65)	1,9 (25,55)	Pirelli Metzeler; Michelin { 130/60 - 13" 53J		1,7 (24,65)	2,1 (30,45)	Bridgestone; Cheng Shin		Tires pressure bar (psi)		Rear tire		Front tire	Rear tire	Eurosawatech; Dunlop		1,7 (24,65)	2,1 (30,45)	Pirelli Metzeler; Michelin { 130/60 - 13" 53J		1,7 (24,65)	2,1 (30,45)	Bridgestone; Cheng Shin	
Tires pressure bar (psi)		Front tire																															
Front tire	Rear tire	Eurosawatech; Dunlop																															
1,7 (24,65)	1,9 (25,55)	Pirelli Metzeler; Michelin { 130/60 - 13" 53J																															
1,7 (24,65)	2,1 (30,45)	Bridgestone; Cheng Shin																															
Tires pressure bar (psi)		Rear tire																															
Front tire	Rear tire	Eurosawatech; Dunlop																															
1,7 (24,65)	2,1 (30,45)	Pirelli Metzeler; Michelin { 130/60 - 13" 53J																															
1,7 (24,65)	2,1 (30,45)	Bridgestone; Cheng Shin																															
7	<p>⚠ WARNING!</p> <p>COOLANT</p> <p>USE ONLY FLUID FOR SEALED CIRCUITS. USE ONLY ANTIFREEZE AND ANTICORROSIVE WITHOUT NITRITE, ENSURING PROTECTION AT -35 C AT LEAST.</p>																																

Ref.	Description																																																
8	<p>MOTORCYCLE NOISE EMISSION CONTROL INFORMATION</p> <p>THIS 1999 ASP21C0049 MOTORCYCLE, 8219457</p> <p>MEETS EPA NOISE EMISSION REQUIREMENTS OF 80 dBA AT 6400 closing r.p.m. BY THE FEDERAL TEST PROCEDURE.</p> <p>MODIFICATIONS WHICH CAUSE THIS MOTORCYCLE TO EXCEED FEDERAL NOISE STANDARDS ARE PROHIBITED BY FEDERAL LAW. SEE OWNER'S MANUAL.</p>																																																
9	<p>⚠ WARNING!</p> <p>Contain sulfuric acid which can cause severe injuries. Avoid contact with skin, eyes or clothing. Antidote: EXTERNAL - Flush with water. INTERNAL - Drink large quantities of water or milk. Follow with milk of magnesia, beaten egg or veg. oil. Call physician immediately. Eyes: Flush with water for 15 minutes and get prompt medical attention.</p> <p>KEEP OUT OF REACH OF CHILDREN.</p> <p>Batteries produce explosive gases. Keep sparks, flames, cigarettes away. Charge only in well-ventilated space. Always wear protective goggles when working around batteries. Always connect the battery vent tube. Failure to heed this warning will cause corrosion of the electrical system.</p>																																																
10	<p>⚠ WARNING!</p> <ul style="list-style-type: none"> •USE UNLEADED FUEL RON min 95 																																																
11	<p>⚠ WARNING!</p> <p>Do not install accessories or replacement parts not approved by Aprilia as original spare parts. Such installation can degrade the handling and safety of your motorcycle and can cause an accident with serious injury or death. See owner's manual.</p>																																																
12	<p>Manufactured by Aprilia s.p.a.</p> <ul style="list-style-type: none"> ○ GVWR: 620 lbs. ○ GAWR: F 200 lbs with 130/60 13" 53 J. tires, E - 13 x 3.50 - DOT - D rim, at 24,6 psi COLD ○ GAWR: R 420 lbs with 130/60 - 53J. tires, E - 13 x 3.50 - DOT - D rim, at 30,5 psi COLD <p>This vehicle conforms to all applicable Federal Motor Vehicle Safety Standards in effect on the date of manufacture shown above.</p> <p>MOTOR DRIVEN CYCLE</p>																																																
13	<p>ATTENTION !</p> <p>THE CERTIFICATION LABEL IS UNDER THE PLASTIC PANEL. TO REMOVE THE PANEL SEE OWNER'S MANUAL.</p>																																																
14	<p>Muffler stamping.</p>																																																
15	<table border="1"> <tr> <td colspan="2">aprilia</td> <td>YEAR</td> <td>T</td> <td>V</td> <td>W</td> <td>X</td> <td>Y</td> </tr> <tr> <td colspan="2">SPARE PARTS CODE NUMBER</td> <td>LM</td> <td>A</td> <td>B</td> <td>C</td> <td>D</td> <td>E</td> </tr> <tr> <td>I</td> <td>UK</td> <td>A</td> <td>P</td> <td>SF</td> <td>B</td> <td>D</td> <td>F</td> </tr> <tr> <td>NL</td> <td>CH</td> <td>DK</td> <td>J</td> <td>SGP</td> <td>PL</td> <td>IL</td> <td>FRK</td> </tr> <tr> <td>BM</td> <td>AUS</td> <td>USA</td> <td>BR</td> <td>RSA</td> <td>NZ</td> <td>CCN</td> <td>HR</td> </tr> <tr> <td></td> <td></td> <td></td> <td></td> <td></td> <td></td> <td>SLO</td> <td></td> </tr> </table>	aprilia		YEAR	T	V	W	X	Y	SPARE PARTS CODE NUMBER		LM	A	B	C	D	E	I	UK	A	P	SF	B	D	F	NL	CH	DK	J	SGP	PL	IL	FRK	BM	AUS	USA	BR	RSA	NZ	CCN	HR							SLO	
aprilia		YEAR	T	V	W	X	Y																																										
SPARE PARTS CODE NUMBER		LM	A	B	C	D	E																																										
I	UK	A	P	SF	B	D	F																																										
NL	CH	DK	J	SGP	PL	IL	FRK																																										
BM	AUS	USA	BR	RSA	NZ	CCN	HR																																										
						SLO																																											

TABLE OF CONTENTS

FOREWORD	1	ADJUSTING THE HEADLIGHT	
INTRODUCTION	1	BEAM VERTICALLY	42
SAFETY WARNINGS	1	ADJUSTING THE HEADLIGHT	
GENERAL SAFETY RULES	2	BEAM HORIZONTALLY	43
CARBON MONOXIDE	2	CHANGING THE HEADLIGHT BULBS	44
GASOLINE	2	REMOVING THE HEADLIGHT	45
HOT COMPONENTS	2	FRONT AND REAR	
USED ENGINE OIL	2	DIRECTION INDICATORS	45
BRAKE FLUID	2	CHANGING THE BULB	45
COOLANT	2	REAR LIGHT	46
BATTERY HYDROGEN GAS AND ELECTROLYTE	2	CHANGING THE BULBS	46
PRECAUTIONS		REMOVING THE REAR LIGHT	46
AND GENERAL INFORMATIONS	3	CHANGING THE LICENSE PLATE BULB	47
BEFORE DISASSEMBLY	3	DASHBOARD	47
DISASSEMBLING THE COMPONENTS	3	CHANGING THE BULBS	47
REASSEMBLING THE COMPONENTS	3	REMOVING THE COMPLETE DASHBOARD	48
HOW TO USE		REMOVING THE DASHBOARD GLASS	48
YOUR SERVICE AND REPAIR MANUAL	4	ELECTRIC CONTROL SUPPORTS	48
ELECTRICAL CONNECTORS	5	REMOVING THE HANDLEBAR CONTROLS	48
TIGHTENING TORQUES	5	BRAKES	49
POSITION OF THE WARNING ADHESIVE LABELS	6	DISC BRAKES	50
TECHNICAL DATA	9	FRONT AND REAR BRAKE	50
TIGHTENING TORQUES	11	CHECKING	51
LUBRICANT CHART	11	TOPPING UP	51
TROUBLESHOOTING	12	REAR DRUM BRAKE 	53
REGULAR SERVICE INTERVALS CHART	14	FRONT WHEEL	54
IDENTIFICATION DATA	15	DISASSEMBLY	54
ARRANGEMENT		CHECKING	55
OF THE MAIN ELEMENTS	15	REASSEMBLY	55
ARRANGEMENT OF THE INSTRUMENTS	16	REAR WHEEL	57
INSTRUMENTS AND INDICATORS	16	DISASSEMBLY	57
THROTTLE	16	GREASING	
CHECKING THE OPERATION		THE REAR BRAKE CAM PIN 	58
OF THE THROTTLE CONTROL	16	BRAKE CALIPERS	59
IDLING ADJUSTMENT	17	REMOVING THE FRONT BRAKE CALIPER	59
ADJUSTING THE THROTTLE CONTROL	18	REMOVING THE REAR BRAKE CALIPER	60
FAIRINGS	19	BRAKE PADS	61
REMOVING		CHECKING WEAR OF THE BRAKE PADS	61
THE PASSENGER GRAB HANDLE	19	CHANGING THE BRAKE PADS	61
REMOVING THE NUMBER PLATE-HOLDER	19	BLEEDING THE BRAKING SYSTEM	62
REMOVING THE LOWER GUARD		BRAKE SHOES 	63
OF THE REAR PART OF THE FAIRING	19	CHECKING THE SHOE WEAR 	63
REMOVING THE REAR PART OF THE FAIRING	19	CHECKING THE THICKNESS	
REMOVING THE RIGHT AND LEFT INSPECTION COVERS	20	OF THE FRICTION MATERIAL 	64
REMOVING THE LOWER SHIELD COVER	20	REPLACING THE SHOES 	64
REMOVING		TRANSMISSION	65
THE COVER SUPPORT ELEMENT	21	CHECKING THE TRANSMISSION OIL LEVEL	65
REMOVING THE FRONT COVER	21	CHANGING THE TRANSMISSION OIL	65
REMOVING THE BATTERY / TOOL KIT COMPARTMENT COVER ...	21	CHECKING THE ENGINE FULCRUM AXIS	66
REMOVING		WHEELS / TIRES	66
THE FRONT INNER SHIELD	22	INSPECTING THE WHEELS	66
REMOVING		TIRES	67
THE REAR-VIEW MIRRORS	22	TIRE PRESSURE	68
REMOVING THE FOOTBOARD	23	FORK HEAD	69
REMOVING THE FRONT MUDGUARD	23	CHECKING THE STEERING	69
REMOVING THE LOWER HANDLEBAR COVER	24	ADJUSTING THE BEARING PLAY	69
PARTIAL REMOVAL OF THE UPPER HANDLEBAR COVER	24	REMOVING THE FORK HEAD BEARINGS	70
REMOVING THE CRASH		FRONT FORK	71
HELMET COMPARTMENT complete with saddle	25	CHECKING THE FORK OIL LEVEL	71
REMOVING THE FRONT SHIELD COVER	25	REMOVING THE COMPLETE FORK	71
REMOVING THE REAR MUDGUARD	26	REMOVING THE LOWER FORK LEG	
INSTALLING THE REAR MUDGUARD EXTENSION	27	(with installed fork)	72
REMOVING THE COVER		DISASSEMBLING THE LOWER FORK LEG	72
OF THE REAR PART OF THE FAIRING	27	REAR SUSPENSION	73
REMOVING THE FRONT OUTER SHIELD	28	REMOVAL	73
REMOVING THE LOWER SHIELD	28	EXHAUST SILENCER	73
FUEL TANK	29	DISASSEMBLY	73
FUEL	29	AIR CLEANER	74
CHECKING THE FUEL VALVE	30	REMOVAL	74
DRAINING THE FUEL TANK	30	CLEANING THE AIR FILTER	74
REMOVING THE FUEL VALVE	31	IGNITION SWITCH / STEERING LOCK	74
CHECKING THE FUEL LEVEL GAUGE UNIT	32	REMOVAL	74
REMOVING THE FUEL LEVEL GAUGE UNIT	32	BATTERY	75
REMOVING THE COMPLETE FUEL TANK	32	BATTERY STORAGE	76
2 STROKE OIL TANK	33	CHECKING AND CLEANING	
CHECKING	33	THE TERMINALS	76
DRAINING	33	REMOVING THE BATTERY	76
REMOVAL	33	CHECKING THE ELECTROLYTE LEVEL	77
BLEEDING THE 2 STROKE OIL TANK	34	RECHARGING THE BATTERY	77
COOLING SYSTEM 	35	INSTALLING THE BATTERY	77
COOLANT 	35	ENGINE	78
CHECKING THE COOLANT LEVEL		REMOVING THE ENGINE FROM THE FRAME	78
AND TOPPING UP 	36	ENGINE 	80
DRAINING THE COOLANT SYSTEM 	37	(liquid-cooled version)	80
CHANGING THE COOLANT 	38	REMOVING	
BLEEDING THE COOLANT SYSTEM 	39	THE ENGINE FROM THE FRAME 	80
REMOVING THE RADIATOR 	40	ENGINE MOUNTING BUSHINGS	81
REMOVING THE COOLANT PUMP 	40	REMOVAL	81
REMOVING THE EXPANSION TANK 	41	ELECTICAL SYSTEM	82
REMOVING THE COOLANT		CONTENTS	82
TEMPERATURE TERMISTOR 	41	CHECKING	
BULBS	42	THE THERMISTOR OPERATION 	94
HEADLIGHT	42		

TECHNICAL DATA



DIMENSIONS	
Max. length	70.47 in (1,790 mm)
Max. length (with rear mudguard extension)	74.02 in (1,880 mm)
Max. width	28.35 in (720 mm)
Max. height (front part of the fairing included)	45.67 in (1,160 mm)
Seat height	32.68 in (830 mm)
Wheelbase	49.21 in (1,250 mm)
Min. ground clearance	6.30 in (160 mm)
Curb weight	207.23 lb (94 kg)
Curb weight 	218.26 lb (99 kg)

ENGINE	
Type	2-stroke with controlled ignition
Number of cylinders	1
Total displacement	3.01 cu in (49.26 cm ³)
Bore / stroke	1.57 in / 1.54 in (40 mm / 39.2 mm)
Compression ratio	12.5 ± 0.5:1
Starting	electric + kick starter
Engine idling rpm	1800 ± 100 rpm
Clutch	automatic centrifugal dry clutch
Change gear	Automatic stepless variator
Cooling	with forced air
Cooling 	liquid cooled

CAPACITY	
Fuel (reserve included)	2.11 US gal (8 ℓ)
Fuel reserve	0.53 US gal (2 ℓ)
Transmission oil	3.72 US fl oz (110 cm ³)
2 stroke oil (reserve included)	1.69 US qt (1.6 ℓ)
2 stroke oil reserve	0.53 US qt (0.5 ℓ)
Coolant 	0.32 US gal (1.2 ℓ) (50% water + 50% antifreeze with ethylene glycol)
Seats	2
Vehicle max. load (driver+passenger+luggage)	396.83 lb (180 kg)
Gross weight limit (GVWR) (*)	620 lb (281 kg)
Permissible wheel loads (GAWR) (*)	
– front	200 lb (91 kg)
– rear	420 lb (190 kg)

(*) These two weights: Gross Vehicle Weight Rating (GVWR) and Gross Axle Vehicle Weight Rating (GAWR); are stamped on the certification plate positioned on the front part of the frame, see pag. 15 (IDENTIFICATION DATA) (FRAME NUMBER).

TRANSMISSION	
Speed change gear	automatic and stepless
Primary	V-belt
Ratios	minimum for stepless change: 2.6 maximum for stepless change: 0.862
Secondary	with gears

CARBURETOR	
Number	1
Model:	standard: DELL'ORTO PHBN 12 alternative: TEI KEI TK3AA
Choke tube	Ø 0.47 in (Ø12 mm)
FUEL SUPPLY	
Fuel	unleaded petrol minimum octane rating (R+M) / 2 method 90
FRAME	
Type	one-beam, split in two at the rear
SUSPENSIONS	
Front	telescopic fork
Wheel stroke	3.54 in (90 mm)
Rear	hydraulic mono-shock absorber
Wheel stroke	2.83 in (72 mm)
BRAKES	
Front	disc brake, Ø 7.48 in (Ø190 mm) with hydraulic actuation
Rear 	drum brake, Ø 4.33 in (Ø110 mm), with mechanic actuation
Rear	disc brake, Ø 7.48 in (Ø190 mm) with hydraulic actuation
WHEEL RIMS	
Type	light alloy
Front	3.50 x 13"
Rear	3.50 x 13"
TIRES	
FRONT	130/60 – 13" – 53J
– inflation pressure for solo rider	24.65 psi [(170 kPa) (1.7 bar)]
– inflation pressure for rider and passenger	24.65 psi [(170 kPa) (1.7 bar)]
REAR	130/60 – 13" – 53J
– inflation pressure for solo rider	27.55 psi [(190 kPa) (1.9 bar)]
– inflation pressure for rider and passenger	30.45 psi [(210 kPa) (2.1 bar)]
IGNITION	
Type	CDI
Spark advance	14° ± 2° before T.D.C.
SPARK PLUG	
Standard	NGK BR7 HS
Standard 	NGK BR8 HS
Spark plug gap	0.020 – 0.024 in (0.5 – 0.6 mm)

ELECTRIC SYSTEM	
Battery	12 V - 4 Ah
Fuse	7.5 A
Generator (with permanent magnet)	12 V - 85 W
BULBS	
Low/high beam	12 V - 35/35 W
Front parking light	12 V - 3 W
Direction indicators	12 V - 10 W
Rear parking light	12 V - 5 W
Rear stoplight	12 V - 21 W
License plate	12 V - 3 W
Dashboard	12 V - 1.2 W
WARNING LIGHTS	
High beam	12 V - 1.2 W
Direction indicators	12 V - 2 W
2 stroke oil reserves	12 V - 2 W
Low fuel	12 V - 1.2 W

TIGHTENING TORQUES	ftlb	Nm
Front wheel pin nut	36.17	50
Rear wheel nut	79.56	110
Connection link-frame fastening screw	36.17	50
Silent-block pin nut	30.38	42
Engine-connection link fastening nut	36.17	50
Handlebar fastening screw	36.17	50
Front brake caliper fastening screw	18.08	25
Rear brake caliper fastening screw	19.53	27
Front wheel fork - pin clamp fastening screw	8.68	12
Brake caliper air valve	2.9-8.68	4-12
Shock absorber fastening upper screw	36.17	50
Shock absorber fastening lower screw	18.08	25
Silencer-cylinder fastening screw	8.68	12
Silencer-engine fastening screw	18.08	25

LUBRICANT CHART

Transmission oil (recommended):  F.C., SAE 75W - 90.

As an alternative to the recommended oil, it is possible to use high-quality oils with characteristics in compliance with or superior to the A.P.I. GL4 specifications.



2 stroke oil (recommended):  GREEN HIT.

Use high-quality oils with characteristics in compliance with or superior to the ISO-L-ETC++, A.P.I. TC++ specifications.

Fork oil (recommended):  F.A. 5W or  F.A. 20W fork oil.

If you need an oil with intermediate characteristics in comparison with the two recommended products, these can be mixed as indicated below:

SAE 10W  F.A. 5W 67% of the volume, +  F.A. 20W 33% of the volume.

SAE 15W  F.A. 5W 33% of the volume, +  F.A. 20W 67% of the volume.

Bearings and other lubrication points (recommended):  AUTOGREASE MP.

As an alternative to the recommended product, use high-quality grease for rolling bearings, working temperature range -30 °C...+140 °C, drop point 150 °C...230 °C, high protection against corrosion, good to water and oxidation resistance.

Protection of the battery poles: neutral grease or vaseline.

Spray grease for chains (recommended):  CHAIN SPRAY.

Brake fluid (recommended):  F.F., DOT 5 (DOT 4 compatible).

WARNING

Use new brake fluid only.

Engine coolant (recommended)  ECOBLU -40 °C.

WARNING

Use only antifreeze and anticorrosive without nitrite, ensuring protection at -35 °C at least.

TROUBLESHOOTING**1.0 ENGINE DOESN'T START OR IS DIFFICULT TO START****CAUSE****1.1 Fuel doesn't reach carburetor.**

- No fuel in the tank.
- Fuel pipe or carburetor filter clogged.
- Needle valve either clogged or blocked.
- Clogged tank bleed plug.
- Fuel valve malfunctions.
- Damaged vacuum pipe.

1.2 Wet spark plug.

- Clogged carburetor float chamber bleed.
- Idling rpm too high (idling mixture too rich).
- Clogged air filter element.

1.3 Ignition spark doesn't flash or is weak.

- Defective spark plug.
- Defective spark plug cable.
- Ignition defective or in short circuit.
- Connecting contacts or terminals loose or defective.

1.4 Engine compression loss.

- Piston rings worn or stuck.
- Damaged head gasket.

1.5 Engine starts, but stops immediately.

- Incorrect ignition timing.
- Broken intake manifold.
- Defective carburetor.

REMEDY

- Check the fuel level in the tank.
- Clean or change the pipe and the filter.
- Clean or release.
- Clean the bleed plug.
- Change.
- Change.
- Clean the bleed.
- Adjust the idling rpm.
- Clean the filter.
- Change.
- Check and, if necessary, change.
- Check and repair.
- Check, tighten and, if necessary, change.
- Change.
- Change.
- Set ignition timing.
- Check and, if necessary, change.
- Check and, if necessary, change.

2.0 ENGINE LACKS POWER**CAUSE****2.1 Wheel doesn't rotate freely.**

- Friction between wheel and brake.
- Wheel bearing worn or damaged.

2.2 Tire pressure too low.

- Punctured tire.
- Defective tire valve.

2.3 Low Power, Poor Acceleration.

- Clogged air filter.
- Limited carburetor flow.
- Clogged silencer.

2.4 Clogged carburetor.

- Service interval too long.

2.5 Dirty spark plug.

- Insufficient spark plug service interval.
- Spark plug heat rating incorrect.

2.6 Engine overheating.

- Heavy deposits in the combustion chamber.
- Fuel quality.
- Too weak fuel-air mixture.

2.7 The engine is noisy (rattles).

- Worn piston rings.
- Insufficient octane fuel.
- Heavy deposits in the combustion chamber.
- Excessively advanced ignition stroke.

REMEDY

- Check the braking system and the alignment of the wheel.
- Change.
- Repair and, if necessary, change.
- Repair and, if necessary, change.
- Clean.
- Clean the carburetor.
- Clean.
- Service more frequently.
- Clean more frequently.
Check the gap between the electrodes.
- Replace with a spark plug with proper heat rating.
- Clean the combustion chamber.
- Use the recommended type of fuel only.
- Adjust the carburation.
- Change.
- Use the recommended fuel.
- Clean the combustion chamber.
- Adjust.

3.0 IRREGULAR FUNCTIONING AT LOW SPEED

CAUSE

- 3.1 Incorrect ignition timing.**
- 3.2 Incorrect adjustment of the carburetor.**
 - Too weak fuel-air mixture.
 - Fuel-air mixture too rich.
- 3.3 Air infiltration in the fuel intake manifold.**
 - Loose carburetor.
 - Defective fuel intake manifold.
- 3.4 Weak or intermittent spark.**
 - Defective stator/coil.

REMEDY

- Set ignition timing.
- Correct the mixture.
- Correct the mixture.
- Tighten properly.
- Change.
- Change.

4.0 IRREGULAR FUNCTIONING AT HIGH SPEED

CAUSE

- 4.1 Limited fuel flow.**
 - No fuel.
 - Clogged fuel pipe.
 - Clogged fuel filter.
 - Fuel valve malfunctions.
 - Damaged vacuum pipe.
- 4.2 Clogged jet.**

REMEDY

- Refuel.
- Clean or change.
- Clean or change.
- Change.
- Change.
- Clean.

5.0 UNSTABLE MANOEUVRABILITY

CAUSE

- 5.1 Heavy steering.**
 - Improper adjustment of the steering head bearing, insufficient clearance (excessive preload).
 - Damaged steering head bearings.
 - Bent fork rod.
- 5.2 One of the two wheels wobbles.**
 - Excessive clearance of the front wheel bearings.
 - Deformed rim.
 - Excessively worn engine pin bearings.
 - Deformed frame.
- 5.3 Vehicle pulls.**
 - Deformed fork stems.
 - Deformed engine connection link.
 - Deformed frame.
- 5.4 Vehicle vibrates.**
 - Check the wear of the connection link silent-blocks.
 - Check the spring at the end of stroke of the connection element

REMEDY

- Loosen and adjust.
- Change.
- Change.
- Change the bearings.
- Change.
- Change.
- Change.
- Change.
- Change.
- Change.
- Change.
- Change.

6.0 ENGINE OVERHEATS

CAUSE

- 6.1 Cooling system defective.**
 - Insufficient coolant.
 - Radiator fin unit clogged by dirt or foreign matters.
 - Coolant passages clogged.
 - Air in the cooling circuit.
 - Coolant pump faulty.
 - Unsuitable coolant.

REMEDY

- Add coolant.
- Clean.
- Clean.
- Bleed the circuit.
- Change.
- Change coolant.

7.0 ENGINE DOES NOT REACH THE RIGHT TEMPERATURE



CAUSE

- 7.1 Particular environmental conditions.**
 - Ambient temperature too cold.
- 7.2 Cooling system defective.**
 - Thermostat locked in total opening position.

REMEDY

- Install protection screen on radiator.
- Clean or change.

REGULAR SERVICE INTERVALS CHART

Component	After running-in [312 mi (500 km)] or 4 months	Every 2,500 mi (4,000 km) or 8 months	Every 5,000 mi (8,000 km) or 16 months
Battery/electrolyte level	C	C	
Spark plug	C	C	S
Air cleaner	C	P	
Brake locking operation	C	C	
Light system	C	C	
Stop light switches		C	
Brake fluid		C	
2 stroke oil level	every 312 mi (500 km): C		
Coolant 	every 1,250 mi (2,000 km): C / every 2 years: S		
Headlight beam direction-operation		C	
Tire pressure	every month: R		
Engine idling rpm	R	C	
Suspension	C	C	
Front and rear brake pad wear	C	every 1,250 mi (2,000 km): C	
Rear brake shoe wear  (check the indicator)	C	C	
Automatic transmission belt			C
Steering bearings and steering	C	C	
Wheel bearings		C	
2 stroke oil filter			P
Braking systems	C	C	
Rear brake cam pin greasing 		C	
Cooling system	C	C	
Brake fluid	every year: S		
Mixer / throttle operation	C	C	
Transmission oil	S	every 1,875 mi (3,000 km): C	every 7,500 mi (12,000 km) or every 2 years: S
Wheels / tires		C	
Nut, bolt, screw tightening	C	C	
Front and rear suspension	C	C	
2 stroke oil reserve warning light	C	C	
Brake fluid bleeding	C		
Fuel pipes	every 2,500 mi (4,000 km): C / every 4 years: S		
Braking system pipes	every 2,500 mi (4,000 km): C / every 4 years: S		
2 stroke oil lines	every 2,500 mi (4,000 km): C / every 4 years: S		

C = check and clean, adjust, lubricate or change, if necessary; **P** = clean; **S** = change; **R** = adjust.
Perform these maintenance operations at one-half of the specified intervals, if your vehicle is often used in rainy or very dusty conditions, or on unpaved roads.

IDENTIFICATION DATA

Please supply the frame number when you purchase spare parts.

NOTE Do not obliterate or alter the identification numbers under any circumstance. This is illegal in all countries. In addition, alteration of the identification numbers invalidates the warranty.

FRAME NUMBER

The frame number is stamped on the central tube of the frame. To be able to read it, it is necessary to remove the cover (1).

NOTE The cover (1) can be inserted in one direction only. The part provided with the tang (2) is the lower part.

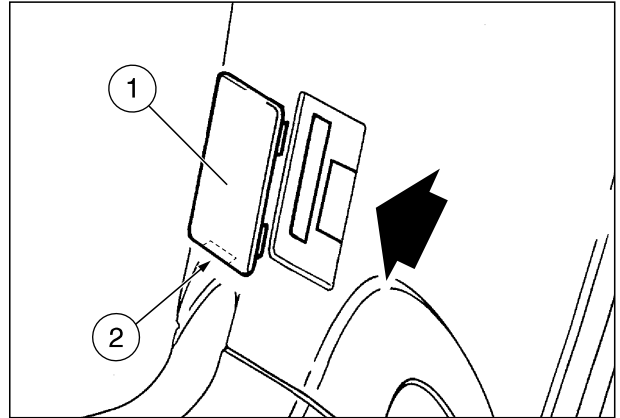

ENGINE NUMBER

The engine number is stamped on the lower support of the rear shock absorber.

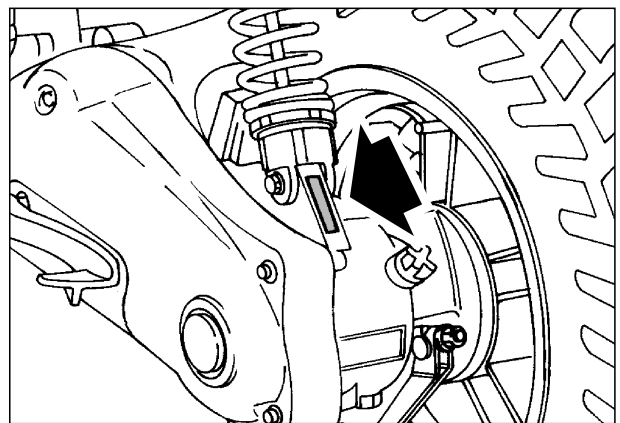

ARRANGEMENT OF THE MAIN ELEMENTS

KEY

- 3) Coolant expansion tank cap
- 4) Bag hook
- 5) Battery/tool kit compartment cover
- 6) Fuel tank
- 7) Fuel filler cap
- 8) Saddle lock
- 9) Kick starter
- 10) Passenger left footrest
- 11) Air cleaner
- 12) Left inspection cover

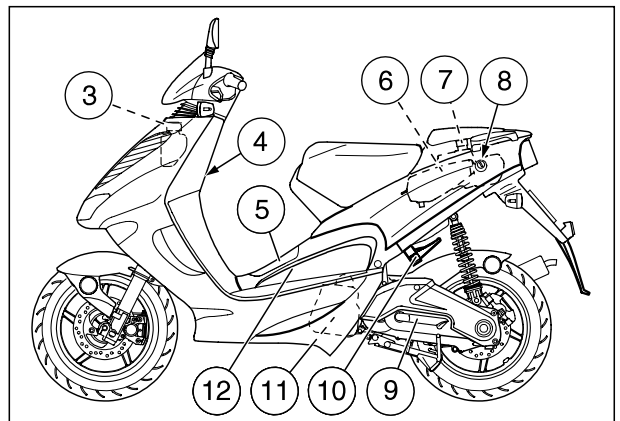

KEY

- 13) 2 stroke oil tank cap
- 14) 2 stroke oil tank
- 15) Ignition switch/steering lock
- 16) Right inspection cover
- 17) Fuse carrier
- 18) Horn
- 19) Battery
- 20) Lower shield cover
- 21) Anti-theft hook (for the **aprilia** "Body-Guard" armored cable **OPTI**).
- 22) Passenger right footrest
- 23) Center stand

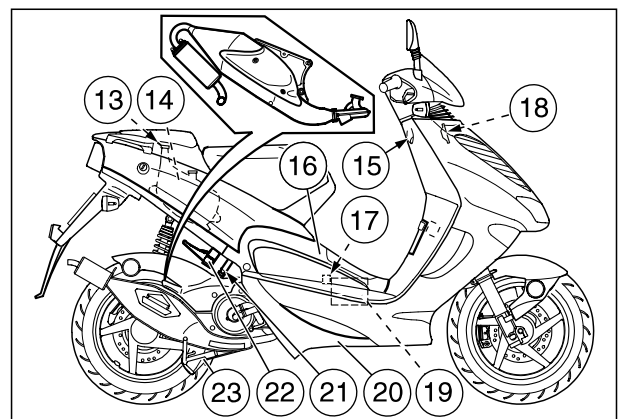

ARRANGEMENT OF THE INSTRUMENTS

KEY

- 1) Electrical controls on the left side of the handlebar
- 2) Cold start lever (L)
- 3) Rear brake lever
- 4) Left rear-view mirror
- 5) Instruments and indicators
- 6) Right rear-view mirror
- 7) Front brake lever
- 8) Throttle grip
- 9) Electrical controls on the right side of the handlebar
- 10) Ignition switch/steering lock (O - X - A)

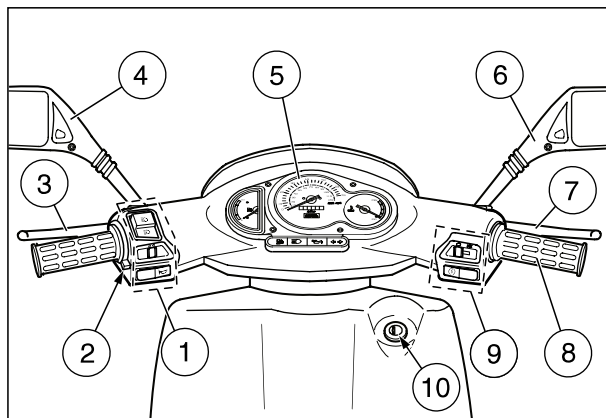

INSTRUMENTS AND INDICATORS

KEY

- 11) Fuel level indicator (M)
- 12) Speedometer
- 13) Total miles odometer
- 14) Coolant temperature indicator (T)
- 15) Green direction indicator warning light (L/R)
- 16) Red 2 stroke oil reserve warning light (OIL)
- 17) Blue high beam warning light (H)
- 18) Amber low fuel warning light (M)

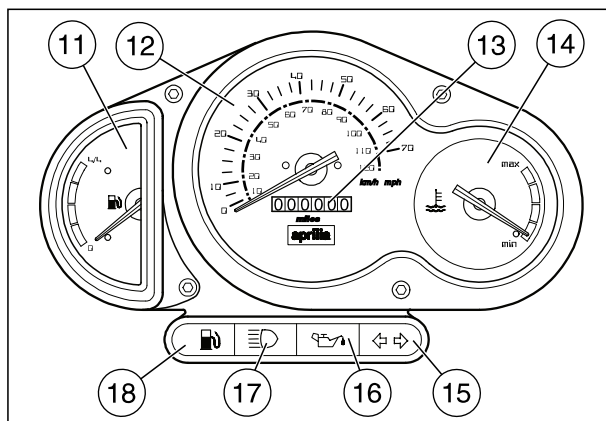

THROTTLE

CHECKING THE OPERATION OF THE THROTTLE CONTROL

Carefully read page 2 (GENERAL SAFETY RULES).

⚠ WARNING

The use of the vehicle with damaged, excessively bent or twisted throttle cable may hinder the regular operation of the throttle and make you lose control of the vehicle while riding. This may lead to an upset with subsequent serious injury or death.

Make sure that the rotation of the front forks does not pull on the throttle cable and change the engine idle speed, and that the throttle grip returns smoothly and automatically to its idle position when released. If it does not:

NOTE For the lubrication of the components use the specific lubricant available on the market.

- ◆ Check the position and lubrication of the following components:
 - throttle cable sheath;
 - throttle grip adjuster (19);
 - carburetor adjuster (20);
 - cable ends;
 - throttle control.
- ◆ Check and adjust the idle speed, see p. 17 (IDLING ADJUSTMENT).

Check the throttle control control adjustment, see above (CHECKING THE OPERATION OF THE THROTTLE CONTROL).

NOTE Use a good grade of vehicle cable lubricant to lubricate the components of the throttle system.

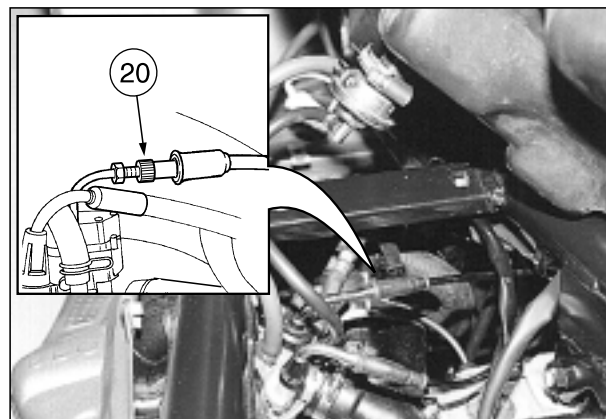
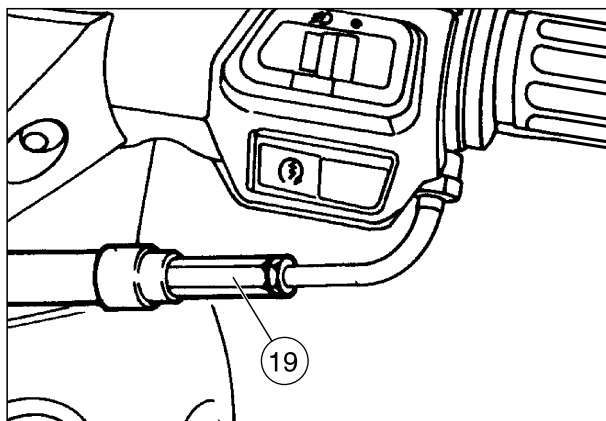

IDLING ADJUSTMENT

Carefully read page 2 (GENERAL SAFETY RULES).

NOTE Before carrying out any operation, check the correct functioning of the throttle control, see p. 16 (CHECKING THE OPERATION OF THE THROTTLE CONTROL).

If the idle becomes irregular, too fast, or too slow, it must be adjusted.

Adjust the idling after the first 312 mi (500 km) and every time it is irregular.

To adjust the idle:

⚠ WARNING

Exhaust gases contain carbon monoxide, which is extremely poisonous if inhaled.

Do not start the engine in closed or badly-ventilated rooms.

Failure to observe this warning may cause loss of consciousness or even lead to death by asphyxia.

- ◆ Ride for a few miles until the engine reaches the normal running temperature, then stop the engine.
- ◆ Place the vehicle on the center stand.
- ◆ Remove the left inspection cover, see p. 20 (REMOVING THE RIGHT AND LEFT INSPECTION COVERS).
- ◆ Connect an electronic revolution counter to the spark plug cable.
- ◆ Start the engine.

The idle speed must be adjusted at 1800 rpm \pm 100 rpm. This is sufficiently fast to keep the engine running smoothly, but sufficiently slow to prevent the transmission from engaging and rotating the rear wheel.

If it does not:

⚠ WARNING

Do not act on the air adjusting screw, to avoid variations of the carburation setting.

- ◆ Adjust the adjusting screw (1) positioned on the carburetor.

By SCREWING IT clockwise, you increase the engine rpm.

By UNSCREWING IT counterclockwise, you decrease the engine rpm.

- ◆ Twist the throttle grip, accelerating and decelerating a few times to make sure that it functions correctly and to check if the idling speed is constant.
- ◆ Stop the engine.
- ◆ Disconnect the electronic revolution counter from the spark plug cable.
- ◆ Replace the left inspection cover, p. 20 (REMOVING THE RIGHT AND LEFT INSPECTION COVERS)

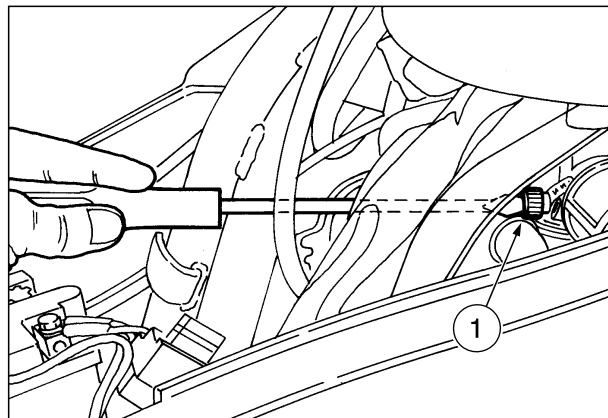

ADJUSTING THE THROTTLE CONTROL

Carefully read page 2 (GENERAL SAFETY RULES).

NOTE Before carrying out any operation, check the correct functioning of the throttle control, see p. 16 (CHECKING THE OPERATION OF THE THROTTLE CONTROL).

⚠ WARNING

If the throttle sticks open, you will lose control of your vehicle and a serious accident could result.

If any fastener in the throttle system becomes loose, likewise you will lose control of your vehicle.

Either situation can lead to an upset or collision with subsequent serious injury or death.

The play of the throttle cable must be between **0.08 – 0.12 in (2 – 3 mm)**, measured at the edge of the grip, see the illustration above.

To adjust the cable:

- ◆ Place the vehicle on the center stand.
- ◆ Pull back the rubber boot (1).
- ◆ Loosen the lock nut (2).
- ◆ Rotate the adjuster (3) in such a way as to restore the prescribed value.
- ◆ After the adjustment, tighten the lock nut (2) and check the play again.
- ◆ Replace the rubber boot (1).

If the play cannot be adjusted to between 0.08-0.012 in (2-3 mm) with the throttle grip adjuster, adjust the carburetor adjuster as follows:

To reach the carburetor adjuster:

- ◆ Partially remove the crash helmet compartment, see p. 25 (REMOVING THE CRASH HELMET COMPARTMENT complete with saddle).

For the adjustment:

NOTE Do not tamper with the protection element of the cold start cable (4).

- ◆ Withdraw the rubber boot (5).
- ◆ Loosen the nut (6).
- ◆ Adjust the carburetor adjuster (7).

After the adjustment:

- ◆ Tighten the nut (6), locking the adjuster (7) and replace the rubber boot (5).

⚠ WARNING

Exhaust gases contain carbon monoxide, which is extremely poisonous if inhaled.

Do not start the engine in closed or badly-ventilated rooms.

Failure to observe this warning may cause loss of consciousness or even lead to death by asphyxia.

⚠ WARNING

After you have adjusted the throttle, rotate the handlebars full left and full right with the engine idling. Check to ensure that the idle sound is not affected by this. Also check that the throttle smoothly and fully closes when released.

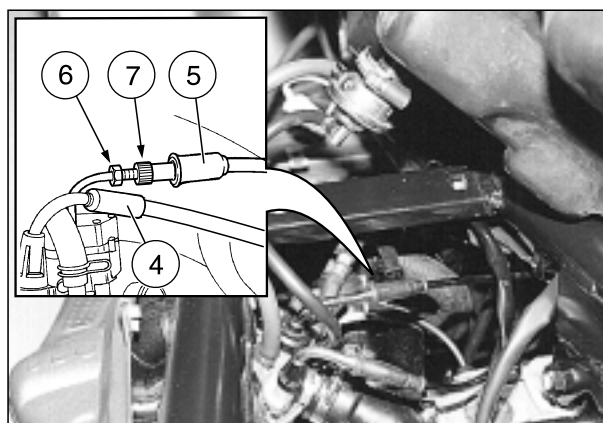
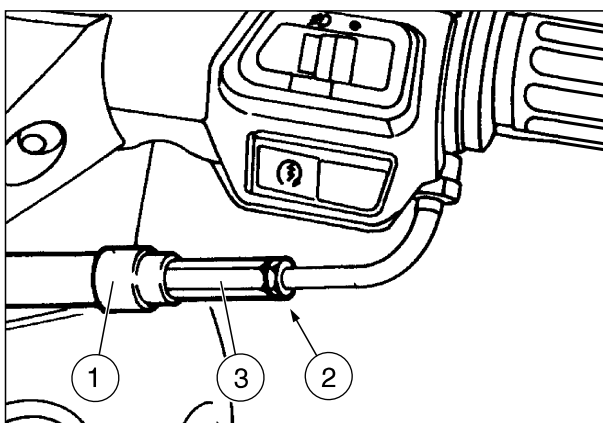
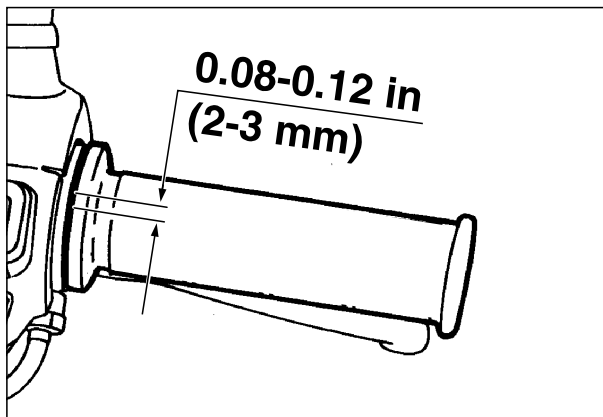

FAIRINGS

Carefully read page 2 (GENERAL SAFETY RULES).

REMOVING THE PASSENGER GRAB HANDLE

- ◆ Place the vehicle on the center stand.
- ◆ Raise the saddle.
- ◆ Unscrew and remove the two screws (1).
- ◆ Unscrew and remove the two screws (2).
- ◆ Remove the passenger grab handle (3).

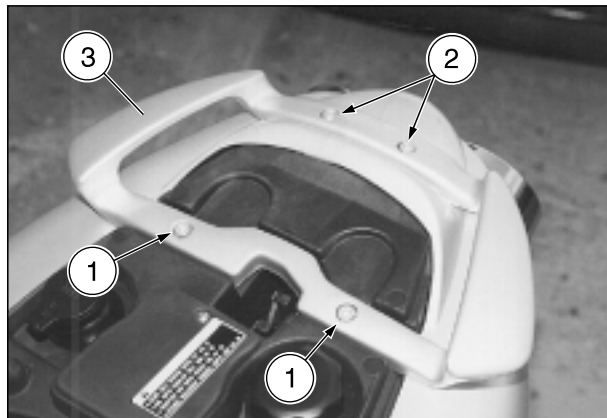

REMOVING THE NUMBER PLATE-HOLDER

- ◆ Place the vehicle on the center stand.
- ◆ ★ Unscrew and remove the two screws (4).
- ◆ Partially remove the number plate-holder. Be careful not to damage or strain the electric wires.

NOTE Do not disconnect the two electric connectors of the direction indicators.

- ◆ Disconnect the main electric connector.
- ◆ Remove the number plate-holder (5) completely, together with the rear light and the rear direction indicators.

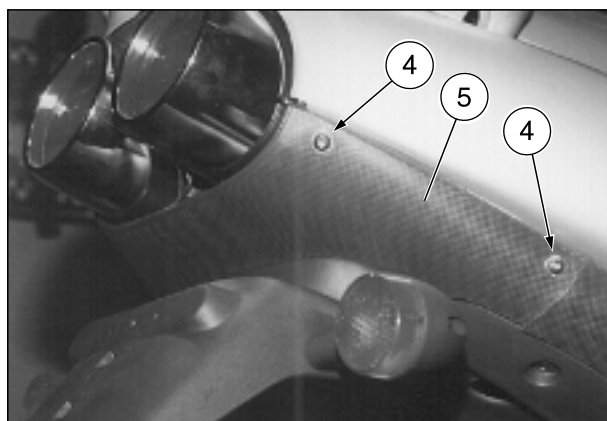

REMOVING THE LOWER GUARD OF THE REAR PART OF THE FAIRING

- ◆ Place the vehicle on the center stand.
- ◆ Remove the number plate-holder, see p. 19 (REMOVING THE NUMBER PLATE-HOLDER).
- ◆ ★ Unscrew and remove the screw (6).

CAUTION

Handle with care. Upon reassembly, insert the tangs (9) and the couplings (8) correctly.

- ◆ Lower the rear part of the guard (7), move it backwards and release it from the couplings (8), then withdraw it from the tangs (9).

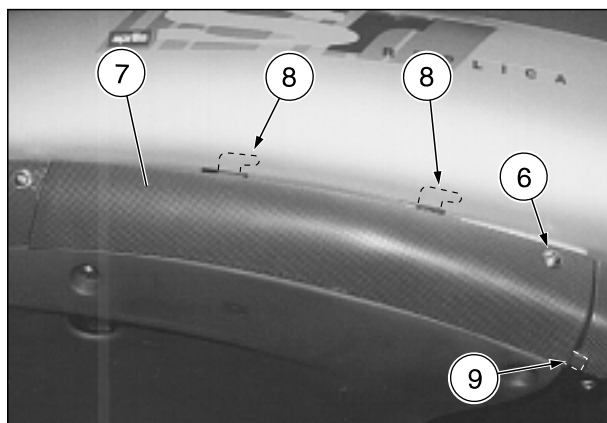

REMOVING THE REAR PART OF THE FAIRING

- ◆ Place the vehicle on the center stand.
- ◆ Raise the saddle.
- ◆ Remove the passenger grab handle, see p. 19 (REMOVING THE PASSENGER GRAB HANDLE).
- ◆ Remove the lower guard of the rear part of the fairing, see p. 19 (REMOVING THE LOWER GUARD OF THE REAR PART OF THE FAIRING).
- ◆ ★ Raise the front part of the rubber guard (10) and remove it.

NOTE Upon reassembly, position the rubber guard correctly.

- ◆ ★ Unscrew and remove the three upper screws (11).

CAUTION

Handle with care. Avoid damaging the plastic or painted components and the two front tangs (12).

- ◆ ★ Withdraw the front tang (12).
- ◆ Slightly separate the front element of the rear part of the fairing, withdraw it from behind and remove it.

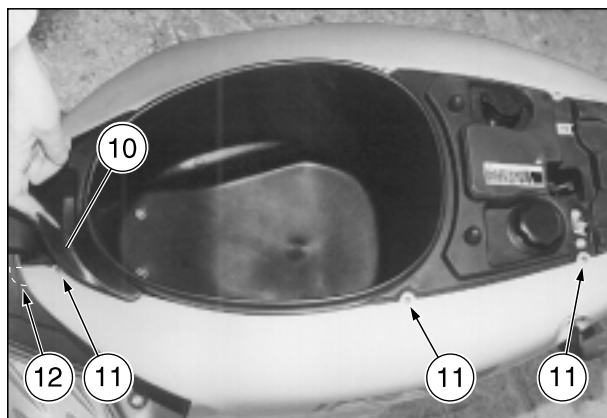

REMOVING THE RIGHT AND LEFT INSPECTION COVERS

Carefully read page 2 (GENERAL SAFETY RULES).

⚠ CAUTION

Handle the plastic or painted components with care and avoid scraping or damaging them.

- ◆ Place the vehicle on the center stand.
- ◆ Remove the battery/tool kit compartment cover (1).
- ◆ Remove the tool kit compartment (2).
- ◆ Unscrew and remove the two screws (3).

NOTE Carry out the following operations on the side of the inspection cover to be removed.

- ◆ Unscrew and remove the screw (4) and the screw (5) of the rear part of the fairing.

NOTE Upon reassembly, fit the screw (5) (with smaller diameter) of the rear part of the fairing in the relevant seat.

- ◆ Slightly raise the inspection cover (6), release it from the footrest and withdraw it sideways.

NOTE Upon reassembly, insert the rear part of the inspection cover in the rear part of the fairing, making the seat (7) coincide with the end of the rear part of the fairing (8).

In points (9) and (10) the left inspection cover must overlap the right inspection cover.

If both inspection covers have been removed, reassemble first the right and then the left cover.

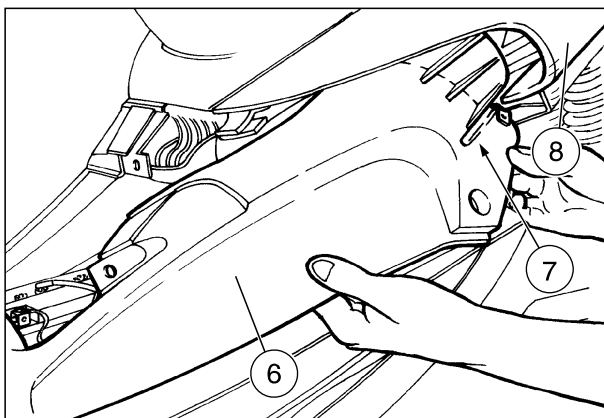
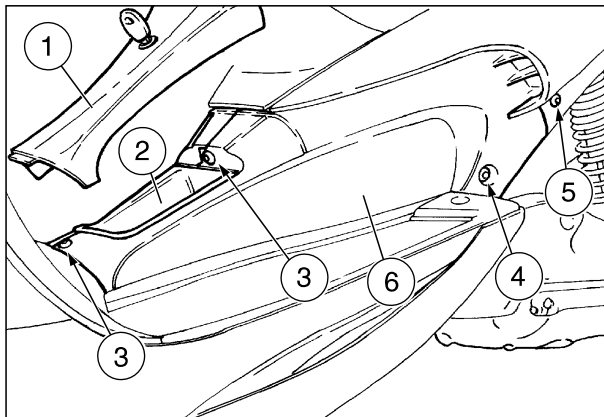

REMOVING THE LOWER SHIELD COVER

Carefully read page 2 (GENERAL SAFETY RULES).

- ◆ Place the vehicle on the center stand.

⚠ WARNING

Before performing the following operations, let the engine and the exhaust silencer cool down until they reach room temperature, in order to avoid burns.

- ◆ Unscrew and remove the screw (11).
- ◆ ★ Lift the rear part of the footboard mat (12).
- ◆ ★ Unscrew and remove the upper screw (13).
- ◆ ★ Unscrew and remove the rear screw (14).
- ◆ ★ Withdraw the side tang (15).
- ◆ Withdraw the two front tangs (16) and remove the lower shield cover.

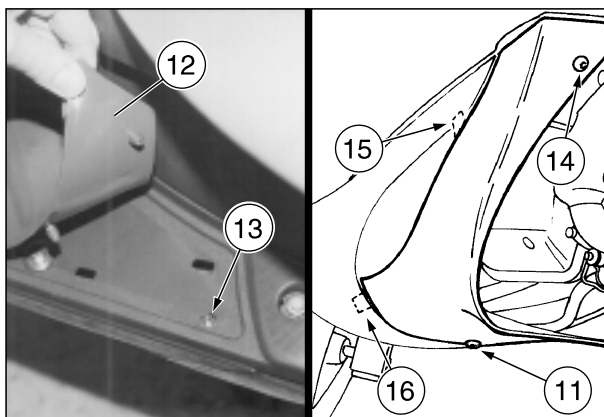
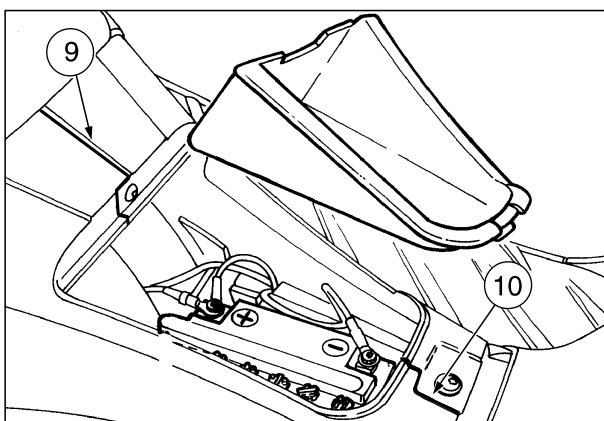

REMOVING THE COVER SUPPORT ELEMENT

Carefully read p. 2 (GENERAL SAFETY RULES) .

- ◆ Place the vehicle on the center stand.
- ◆ Rotate the handlebar completely, unscrew and remove the screws (1).
- ◆ Remove the cover support element (2).

NOTE Upon reassembly, fit the tangs correctly in the appropriate seats.

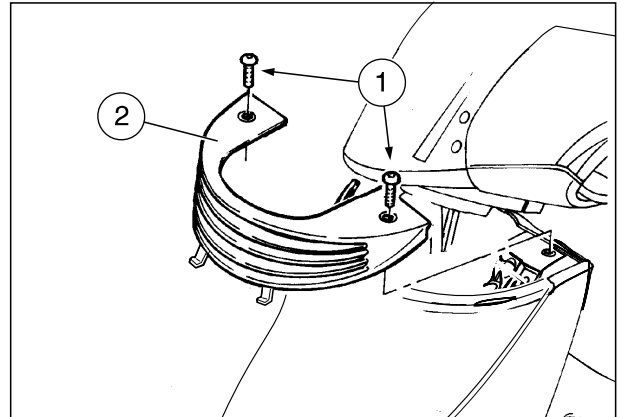

REMOVING THE FRONT COVER

Carefully read p. 2 (GENERAL SAFETY RULES) .

- ◆ Remove the cover support element (2), see above (REMOVING THE COVER SUPPORT ELEMENT).
- ◆ Rotate the handlebar completely, unscrew and remove the screws (3), taking the washers.

CAUTION

Proceed with care.
Do not damage the tangs and/or their seats.
Handle the plastic and painted components with care and avoid scraping or damaging them.

- ◆ Remove the front cover (4), by pulling it upwards.

NOTE Upon reassembly, correctly insert the lower tang (5) and successively the four (two for the version) side tangs (6) in their seats.

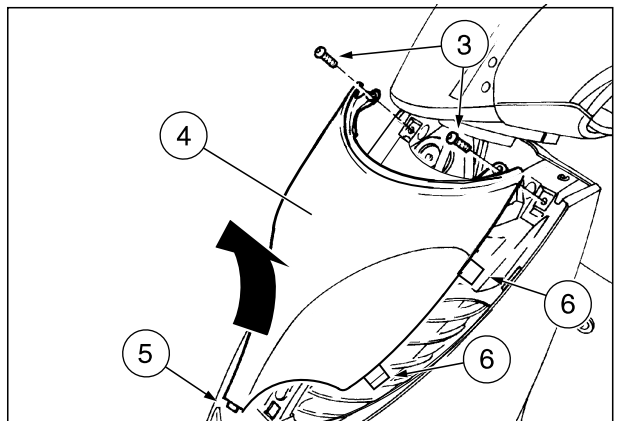

REMOVING THE BATTERY / TOOL KIT COMPARTMENT COVER

Carefully read p. 2 (GENERAL SAFETY RULES) .

- ◆ Insert the key (7) in the lock.
- ◆ Rotate the key (7) clockwise, pull it and remove the cover (8).

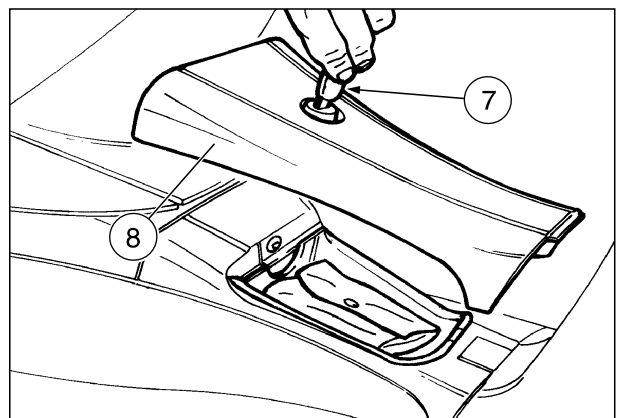
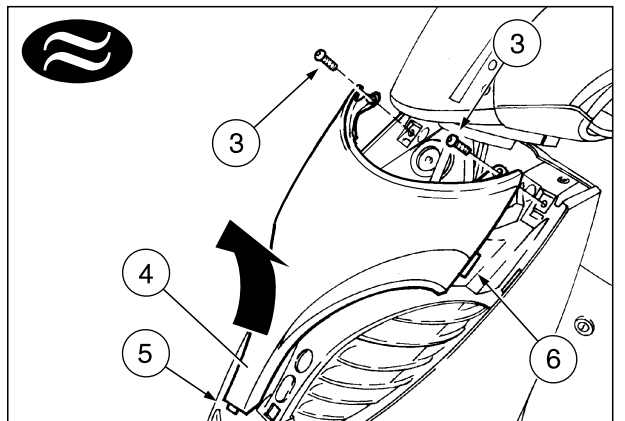

REMOVING THE FRONT INNER SHIELD

Carefully read page 2 (GENERAL SAFETY RULES).

NOTE Remove the key from the ignition switch.

- ◆ Place the vehicle on the center stand.
- ◆ ★ Unscrew and remove the two screws (1).
- ◆ ★ Remove the footrest mat (2).
- ◆ Unscrew and remove the two fastening screws (3) of the bag hook.
- ◆ Remove the bag hook (4).
- ◆ Unscrew and remove the screw (5) with the relevant washer.
- ◆ ★ Unscrew and remove the three screws (6).
- ◆ ★ Unscrew and remove the screw (7).

⚠ CAUTION

Proceed with care.
Do not damage the tangs and/or their seats.

Handle the plastic or painted components with care and avoid scraping or damaging them.

- ◆ Withdraw and remove the front inner shield, rotating it toward the saddle.

REMOVING THE REAR-VIEW MIRRORS

Carefully read page 2 (GENERAL SAFETY RULES).

- ◆ Place the vehicle on the center stand.

NOTE Group the components of the right and left mirror separately.

- ◆ Remove the cover (8).

⚠ CAUTION

Hold the rear-view mirror (9), to prevent it from accidentally falling down.

- ◆ Unscrew the screw (10).
- ◆ Remove the rear-view mirror (9).
- ◆ Remove the gasket (11).

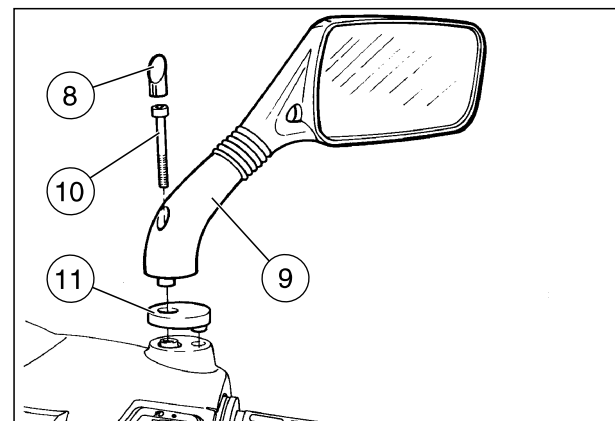
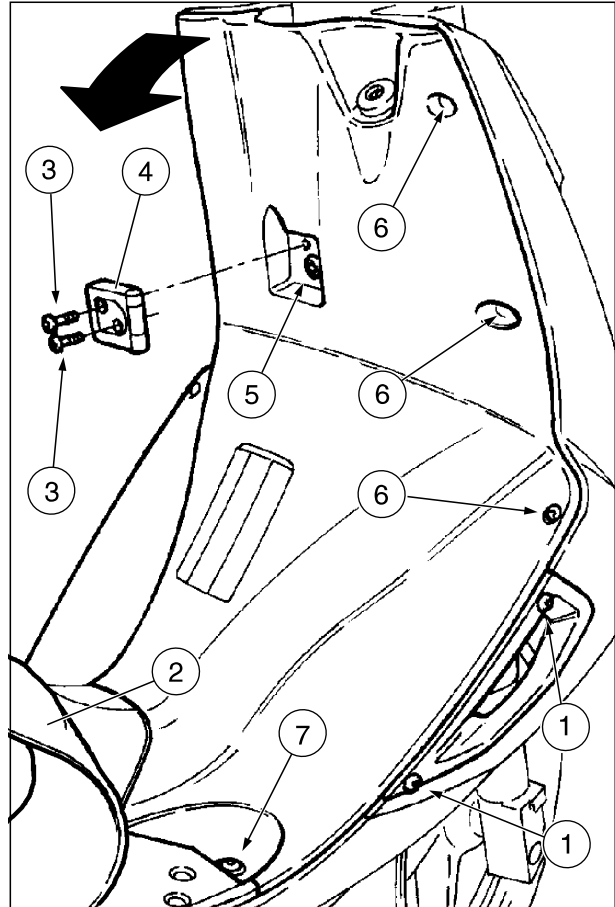

REMOVING THE FOOTBOARD

Carefully read page 2 (GENERAL SAFETY RULES).

- ◆ Remove the inspection covers, see p. 20 (REMOVING THE RIGHT AND LEFT INSPECTION COVERS).
- ◆ Remove the front inner shield, see p. 22 (REMOVING THE FRONT INNER SHIELD).
- ◆ Disconnect first the negative cable (-) and then the positive cable (+) from the battery.

⚠ WARNING

Upon reassembly, connect first the positive cable (+) and then the negative cable (-).

- ◆ Disconnect the battery breather tube.

⚠ CAUTION

Handle the battery with care. Do not overturn it and take care not to let the electrolyte flow out.

- ◆ Extract the battery, see page 77 (CHECKING THE ELECTROLYTE LEVEL).
- ◆ ★ Unscrew and remove the two screws (1), taking the washers.
- ◆ ★ Unscrew and remove the screw (2), taking the bush.
- ◆ ★ Unscrew and remove the screw (3).
- ◆ ★ Unscrew and remove the screw (4) and the rear screw (5).

NOTE Handle with care. Do not force the lower shield.

- ◆ ★ Shift the lower shield as much as necessary, see p. 28 (REMOVING THE FRONT OUTER SHIELD); unscrew and remove the screw (6).
- ◆ Remove the footboard from its seat.

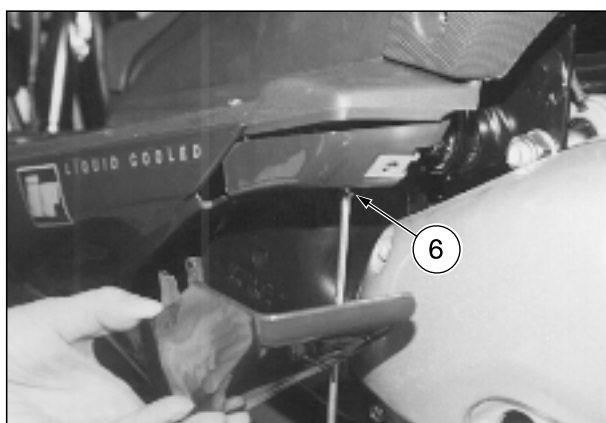
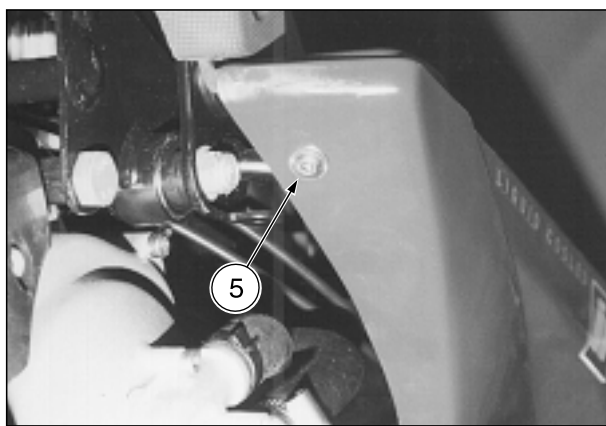
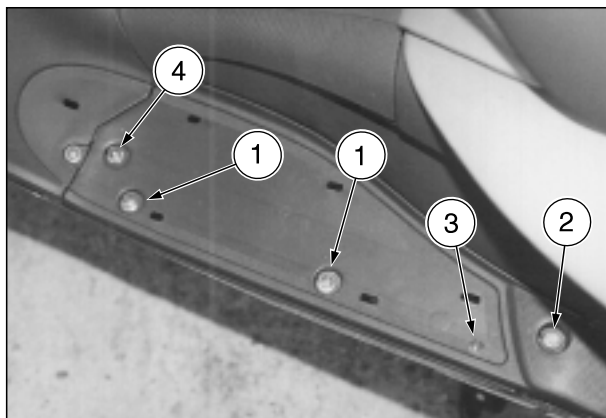

REMOVING THE FRONT MUDGUARD

- ◆ Place the vehicle on the center stand.
- ◆ ★ Unscrew and remove the screw (7).
- ◆ ★ Unscrew and remove the screw (8).

NOTE Upon reassembly, make sure that the nut-holding rubber element on the mudguard is correctly positioned.

- ◆ Remove the rubber element of the front brake pipe and of the odometer/speedometer control cable from the seat on the mudguard.
- ◆ Remove the mudguard by withdrawing it from the front part.

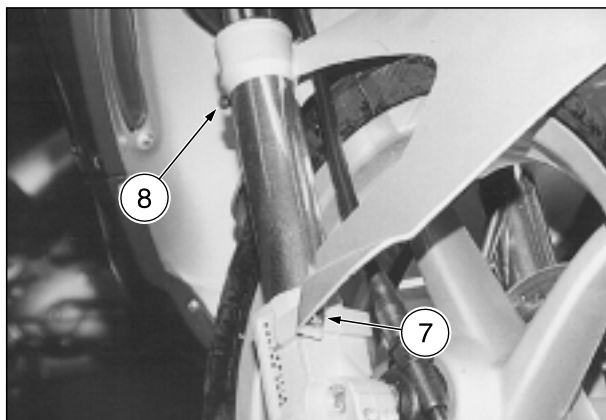

REMOVING THE LOWER HANDLEBAR COVER

Carefully read p. 2 (GENERAL SAFETY RULES) .

- ◆ Remove the cover support element, see p. 21 (REMOVING THE COVER SUPPORT ELEMENT).

NOTE Support the front part of the fairing (1), to prevent it from accidentally falling down.

- ◆ ★ Unscrew and remove the two screws (2).

⚠ CAUTION

Handle the plastic or painted components with care and avoid scraping or damaging them.

- ◆ Remove the rear part of the fairing (1).
- ◆ ★ Unscrew and remove the screw (3).
- ◆ ★ Rotate the handlebar completely clockwise, unscrew and remove the screw (4) (smaller diameter than the other screws) and the screws (5) (6) and (7).

NOTE Upon reassembly, fit the screws (4) (smaller diameter than the other screws) in the relevant seats.

- ◆ Center the handlebar, withdraw the lower handlebar cover (8) from the front, and remove it.

PARTIAL REMOVAL OF THE UPPER HANDLEBAR COVER

Carefully read p. 2 (GENERAL SAFETY RULES) .

- ◆ Remove the rear-view mirrors, see p. 22 (REMOVING THE REAR-VIEW MIRRORS).
- ◆ Remove the lower handlebar cover, see see above (REMOVING THE LOWER HANDLEBAR COVER).
- ◆ ★ Disconnect the two electric terminals (9).

⚠ CAUTION

The upper handlebar cover (10) (complete with switches, instruments and indicators) remains connected with the speedometer cable and with the electric cables, which makes it impossible to remove it completely.

Proceed with care in order to avoid damaging the components.

- ◆ Paying attention to the two switch connections (11), lift the upper handlebar cover and rotate it forwards, then rest it on the front shield.

NOTE Upon reassembly, when positioning the upper handlebar cover, pass the electric terminal cables (9) behind and under the handlebar.

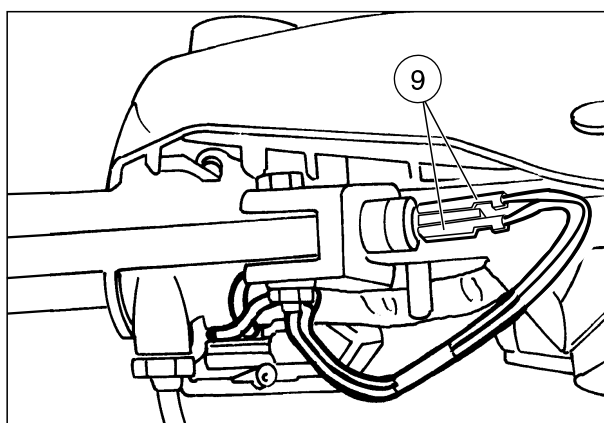
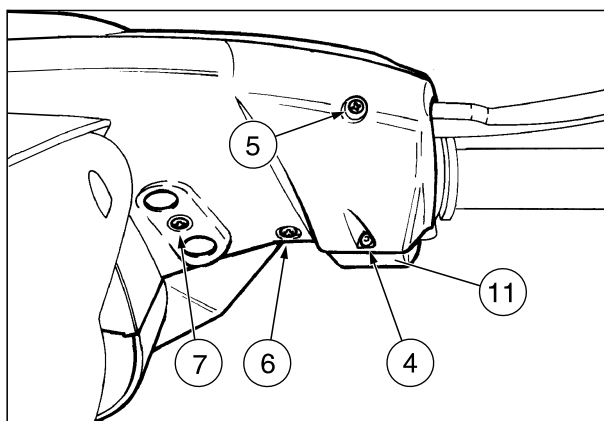
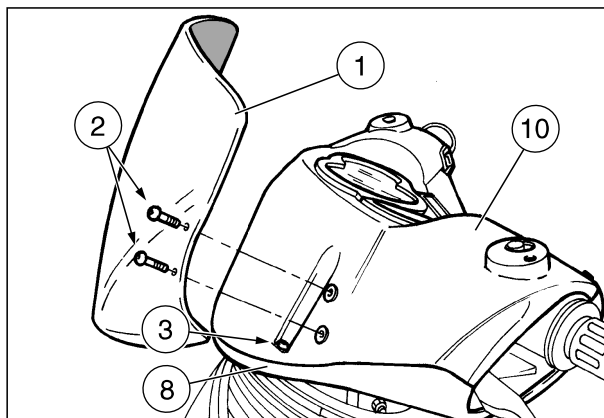

REMOVING THE CRASH HELMET COMPARTMENT complete with saddle

Carefully read page 2 (GENERAL SAFETY RULES).

- ◆ Place the vehicle on the center stand.
- ◆ Raise the saddle.
- ◆ Remove any object from the crash helmet compartment (crash helmet, tool kit, use and maintenance manual, etc.).
- ◆ Remove the rear part of the fairing, see p. 19 (REMOVING THE REAR PART OF THE FAIRING).
- ◆ Unscrew and remove the two screws (1) positioned inside the crash helmet compartment, taking the washer.
- ◆ Unscrew and remove the screws (2).
- ◆ Remove the cover (3) from the fuel level sensor compartment.
- ◆ Withdraw the fuel tank breather pipe (4).
- ◆ Disconnect the electric connector (5) from the fuel level sensor and withdraw it.
- ◆ Release the pipes of the fuel system and of the 2 stroke oil system from the clamp.
- ◆ Lower the saddle.

NOTE The 2 stroke oil tank and the fuel tank remain installed on the crash helmet compartment.

⚠ CAUTION

Proceed with care.

Avoid forcing and damaging the fuel system and 2 stroke oil pipes.

- ◆ Lift the crash helmet compartment (complete with saddle) and remove it partially.

NOTE For the complete removal of the crash helmet compartment (complete with saddle), remove the 2 stroke oil tank, see p. 33 (2 STROKE OIL TANK - REMOVAL), and the fuel tank, see p. 32 (REMOVING THE COMPLETE FUEL TANK).

REMOVING THE FRONT SHIELD COVER

Carefully read page 2 (GENERAL SAFETY RULES).

- ◆ Place the vehicle on the center stand.
- ◆ Unscrew and remove the screw (6).
- ◆ ★ Unscrew and remove the screw (7).
- ◆ Remove the front shield cover (8).

NOTE Upon reassembly, fit the tangs (9) correctly in the appropriate seats.

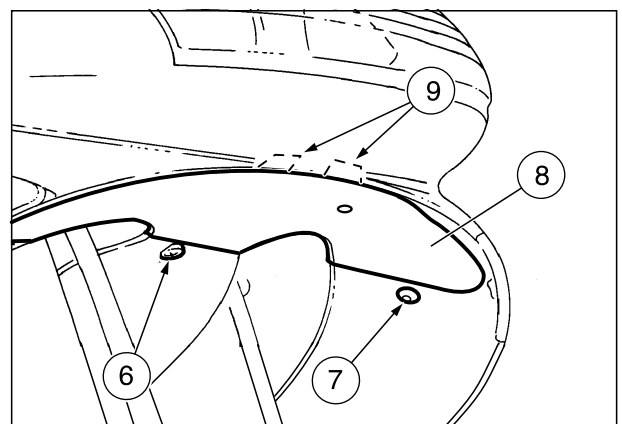
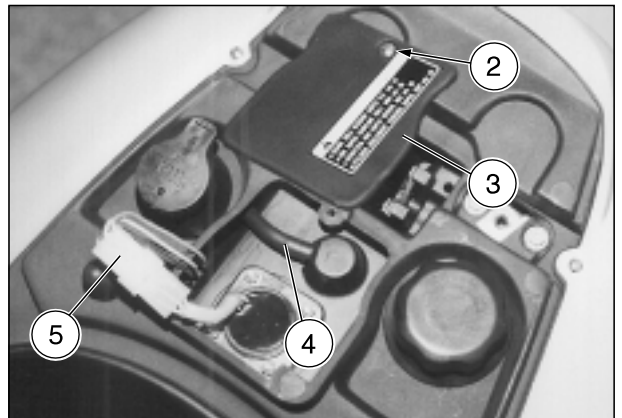
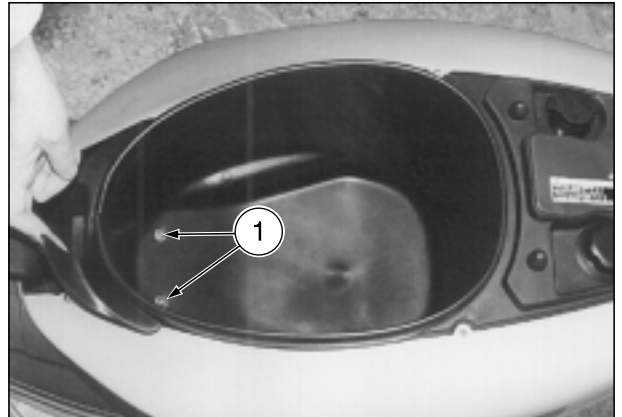

REMOVING THE REAR MUDGUARD

Carefully read page 2 (GENERAL SAFETY RULES).

- ◆ Place the vehicle on the center stand.

⚠ WARNING

Before performing the following operations, let the engine and the exhaust silencer cool down until they reach room temperature, in order to avoid burns.

- ◆ Unscrew and remove the screw (1), taking the two bushes.
- ◆ Unscrew and remove the screw (2), taking the washer and the bush.
- ◆ Unscrew and remove the two screws (3), taking the washers and the bushes.
- ◆ Unscrew and remove the screw (4), taking the special washer.

NOTE Be careful of the position of the special washer of the screw (4), to avoid any problem in the reassembly.

- ◆ Remove the speed variator cover (5).
- ◆ Unscrew and remove the two screws (6).
- ◆ Raise the mudguard, rotate its front part rightwards and remove it.

⚠ CAUTION

Be extremely careful when removing the mudguard support bracket (7).

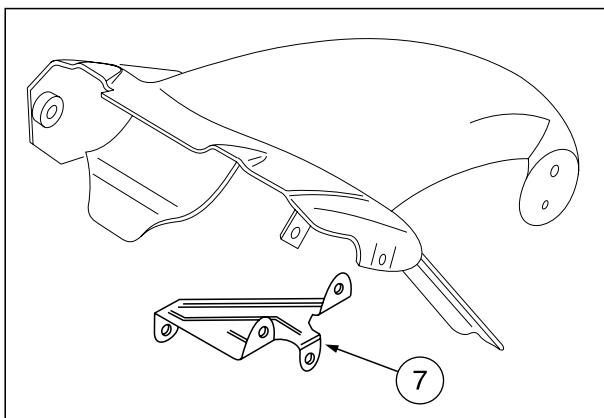
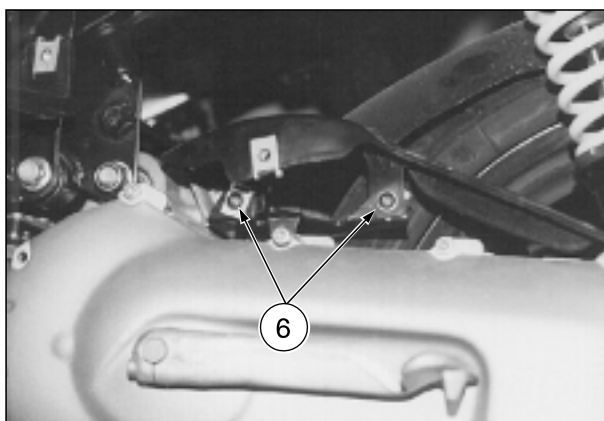
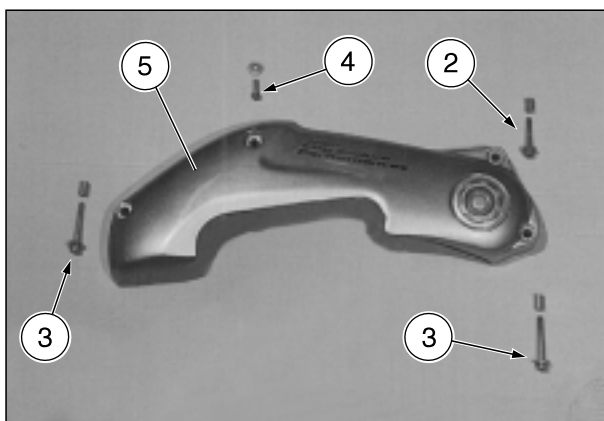
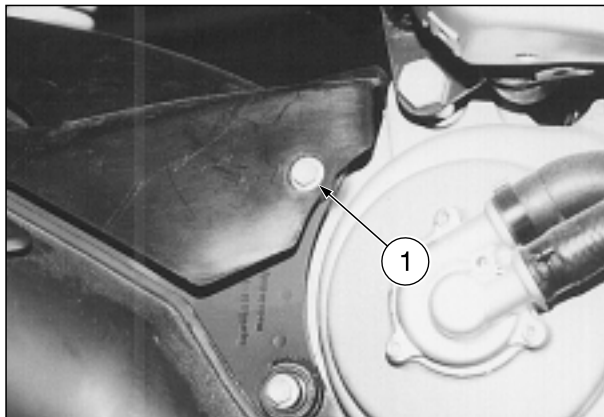

INSTALLING THE REAR MUDGUARD EXTENSION

Carefully read p. 2 (GENERAL SAFETY RULES).

- ◆ Place the vehicle on the center stand.

⚠ WARNING

Before carrying out the following operations, let the engine and the exhaust silencer cool down until they reach room temperature, in order to avoid burns.

- ◆ Grasp the bulb socket (1), pull and take it out of its seat.
- ◆ Release the license plate light cable (2) from the two clips (3).
- ◆ Unscrew and remove the two nuts (4).
- ◆ Remove the license plate light (5).
- ◆ Unscrew and remove the nut (6).
- ◆ Withdraw the screw (7).
- ◆ Position the rear mudguard extension (8) inside the number plate holder support (9).
- ◆ Position the license plate light (5) correctly on the mudguard seat.
- ◆ Screw and tighten finger tight the two nuts (4).
- ◆ Position the bulb socket (1) correctly in its seat.
- ◆ Insert the license plate light cable (2) in the two clips (3).

NOTE We have not ever completely tightened nut (6). It is only finger tightened above.

- ◆ Insert the screw (7) and tighten finger tight nut (6).
- ◆ Make sure that the rear mudguard extension (8) is positioned correctly.
- ◆ Tighten the two nuts (4).
- ◆ Tighten the screw (7).

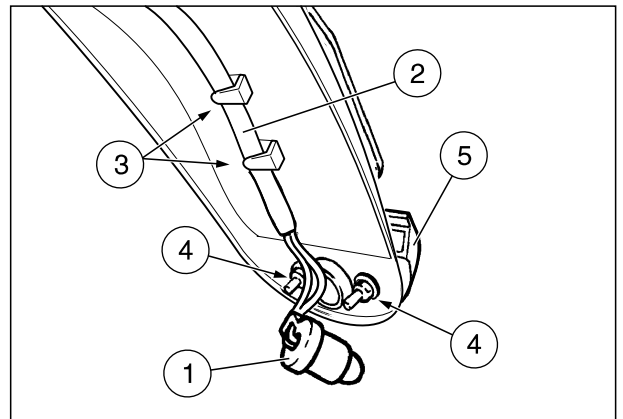

REMOVING THE COVER OF THE REAR PART OF THE FAIRING

Carefully read page 2 (GENERAL SAFETY RULES).

- ◆ Place the vehicle on the center stand.
- ◆ ★ Unscrew and remove the two screws (10).
- ◆ Remove the cover of the rear part of the fairing (11).

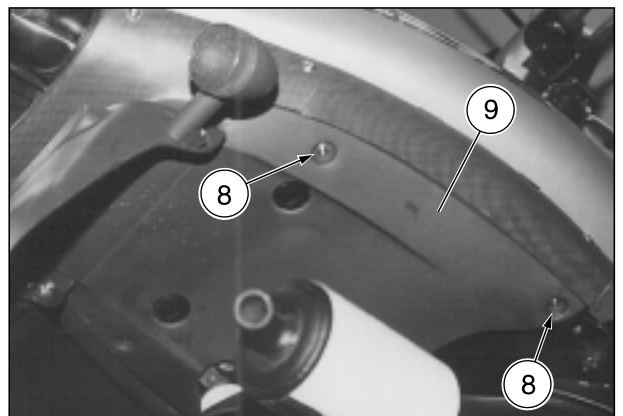
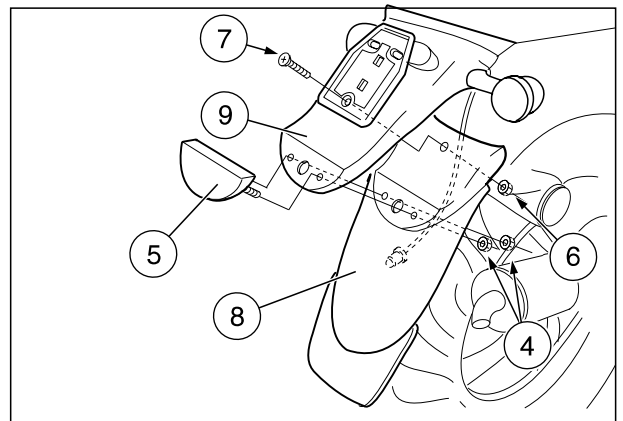

REMOVING THE FRONT OUTER SHIELD

Carefully read page 2 (GENERAL SAFETY RULES).

NOTE For the partial removal, DO NOT PERFORM the operations marked with "X".

⚠ WARNING

X Place a proper support under the vehicle, in order to prevent it from falling down.

- ◆ **X** Position the vehicle on the center stand on a lifting platform, with the front wheel protruding from the platform edge.
- ◆ **X** Raise the platform at 50-60 cm from the ground, in order to be able to withdraw the front outer shield from the fork (after performing the following operations).
- ◆ Remove the front inner shield, see p. 22 (REMOVING THE FRONT INNER SHIELD).
- ◆ ★ Disconnect the two terminals of the front direction indicator.
- ◆ **X** Remove the front wheel, see p. 54 (FRONT WHEEL - DISASSEMBLY).
- ◆ **X** Remove the front mudguard, see p. 23 (REMOVING THE FRONT MUDGUARD).
- ◆ ★ Unscrew and remove the three screws (1).
- ◆ ★ Unscrew and remove the screw (2).
- ◆ ★ Unscrew and remove the screw (3).

⚠ CAUTION

Handle the plastic or painted components with care and avoid scraping or damaging them.

⚠ CAUTION

For the partial removal: put a cloth on the front mudguard to protect it.

- ◆ Partially remove the front outer shield and put it on the cloth.
- ◆ **X** Remove the front outer shield by withdrawing it from the fork.

REMOVING THE LOWER SHIELD

Carefully read page 2 (GENERAL SAFETY RULES).

- ◆ Remove the lower shield cover, see p. 20 (REMOVING THE LOWER SHIELD COVER).
- ◆ ★ Unscrew and remove the three screws (1).
- ◆ ★ Unscrew and remove the screw (2).
- ◆ ★ Unscrew and remove the screw (4), taking the washer.

⚠ CAUTION

Handle the plastic or painted components with care and avoid scraping or damaging them.

- ◆ Remove the lower shield from its seat.

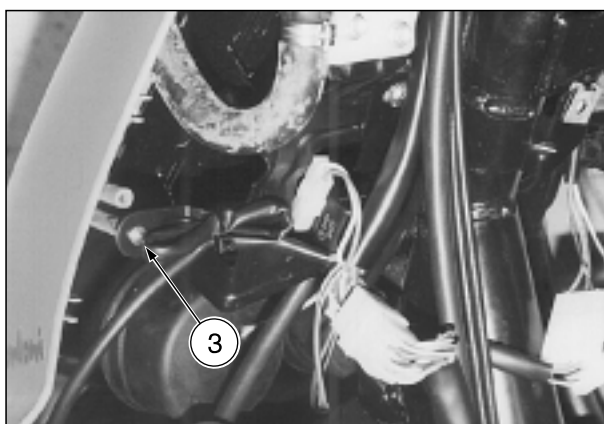
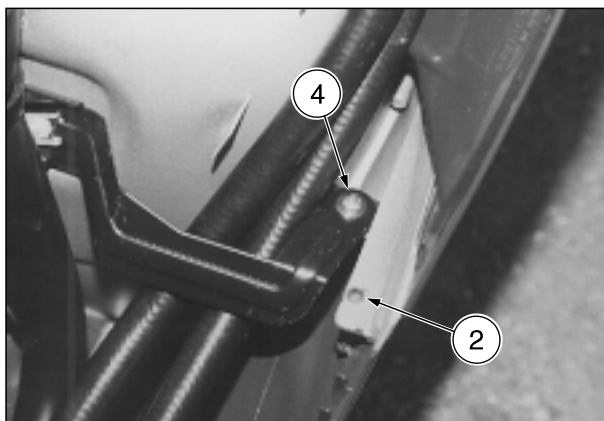
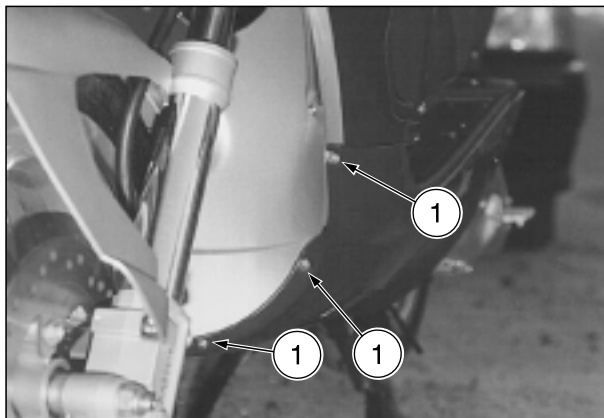

FUEL TANK

Carefully read page 2 (GENERAL SAFETY RULES).

FUEL**⚠ WARNING**

Gasoline is extremely flammable and in some conditions can become explosive.

Therefore, it is necessary to refuel and carry out maintenance operations involving the fuel system in a well-ventilated area with the engine off.

Do not refuel or do any maintenance on the fuel system with the engine running.

Do not smoke while refueling or near fuel vapors.

Never allow any portion of the fuel system to come in contact with naked flames, sparks or other heat sources. Be careful to avoid spilling fuel when you are refueling. Spilled fuel could ignite when it contacts hot engine or exhaust system surfaces. If you accidentally spill some fuel, make sure that it is wiped up or completely evaporated before starting the vehicle.

Since gasoline expands in the fuel tank when the vehicle is sitting in the open sun, never fill the tank completely to the brim. Leave at least one inch of expansion space.

Avoid any contact of the fuel with your skin, and avoid inhalation of fuel vapors. Do not ever attempt to siphon fuel from one container to another using your mouth as suction for a siphon hose.

⚠ WARNING

Gasoline is poisonous and carcinogenic and contains chemical substances that cause birth defects and other reproductive problems. If gasoline should be accidentally spilt on the skin or clothes, immediately wash it off with soap and water and change clothes.

Should you accidentally spill gasoline in your eyes, flush with a large quantity of water and immediately contact a health professional. Should you accidentally get gasoline into your mouth, do not induce vomiting. Drink a large quantity of milk or clear water and immediately contact a health professional.

Never try to siphon gasoline by sucking it with your mouth. Use a manual pump or a similar system.

If your vehicle overturns, it will leak gasoline which is extremely flammable. Flames or sparks may ignite this which will not only destroy the vehicle but also could do serious property damage to surrounding property and cause serious injuries or even death.

ALWAYS KEEP GASOLINE AWAY FROM CHILDREN.

DISPOSE OF UNWANTED GASOLINE PROPERLY, DO NOT DUMP IT INTO STORM SEWERS OR INTO A SINK OR TOILET.



CHECKING THE FUEL VALVE

Carefully read p. 29 (FUEL TANK).

- ◆ Remove the crash helmet compartment, see p. 25 (REMOVING THE CRASH HELMET COMPARTMENT complete with saddle).
- ◆ Disconnect the fuel tube (1) from the carburetor and put its free end into a suitable container.
- ◆ Replace the crash helmet compartment.
- ◆ Leaving the throttle closed, spin the engine with the starter. Check for regular fuel flow.

If the flow is irregular, or if there is no flow:

- A) Check the soundness of the vacuum tube (2) and if necessary clean or replace it.
- B) Check the soundness of the fuel tube (1) and if necessary clean or change it.
- C) Disconnect the vacuum tube (2) from the carburetor, insert a syringe in the free end and suck. The fuel should flow out of the free end of the fuel pipe (1).
- D) Remove the fuel valve (3), see p. 31 (REMOVING THE FUEL VALVE).

⚠ WARNING

Do not attempt to use your mouth for this test. Make sure that the valve filter is free from contamination and, if necessary, clean it.

- ◆ If none of these operations is successful, change the fuel valve.

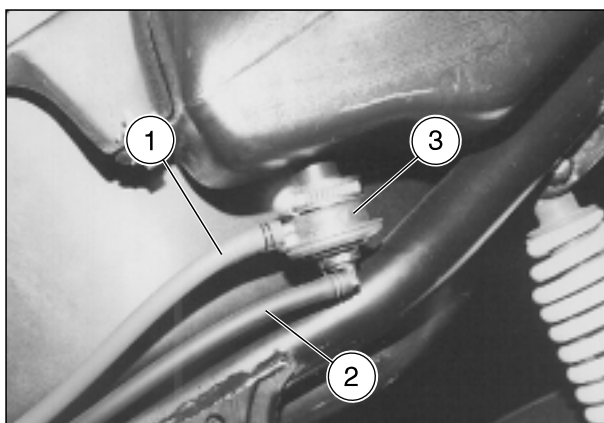
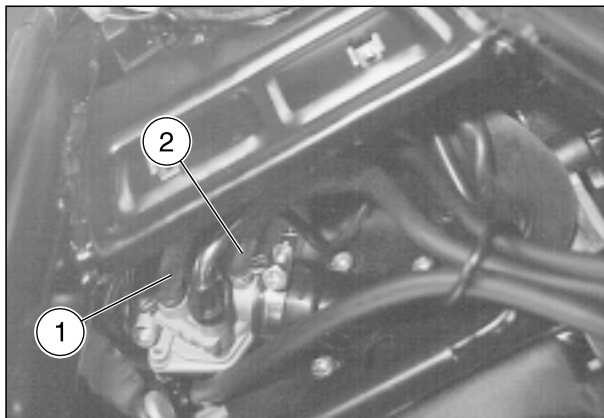

DRAINING THE FUEL TANK

Carefully read page 29 (FUEL).

- ◆ Stop the engine and wait until it has cooled down.
- ◆ Empty the fuel tank by means of a manual pump or a similar system.

To empty the carburetor completely, proceed as follows:

- ◆ Remove the left inspection cover, see p. 20 (REMOVING THE RIGHT AND LEFT INSPECTION COVERS).
- ◆ Remove the filter casing, see p. 74 (AIR CLEANER - REMOVAL).
- ◆ Put the free end of the pipe (4) into a receptacle.
- ◆ Open the carburetor breather by loosening the drain screw (5) positioned under the float chamber.

When all the fuel has flowed out:

- ◆ Tighten the drain screw (5) until the breather shuts.

NOTE Tighten the drain screw (5) carefully, to avoid fuel leaks from the carburetor breather pipe during the refuelling.

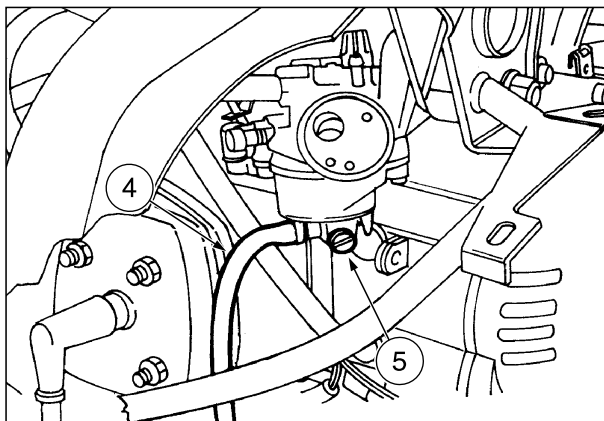

REMOVING THE FUEL VALVE

- ◆ Remove the lower guard of the rear part of the fairing, see p. 19 (REMOVING THE LOWER GUARD OF THE REAR PART OF THE FAIRING).

⚠ CAUTION

Do not dispose of fuel in the environment.

- ◆ Drain the fuel tank completely, see p. 30 (DRAINING THE FUEL TANK).
- ◆ Put the fuel in a container, plug it and store it in a safe place.
- ◆ Disconnect the fuel tube (2) and the vacuum tube (3) from the fuel valve (1).
- ◆ Loosen the clamp (4).

⚠ CAUTION

During disassembly, do not damage the filter on the fuel valve.

- ◆ Withdraw and remove the valve.

NOTE Reassemble the fuel valve in its original position. Take great care to insure that the fuel and vacuum tubes are not crimped or routed where they may be obstructed.

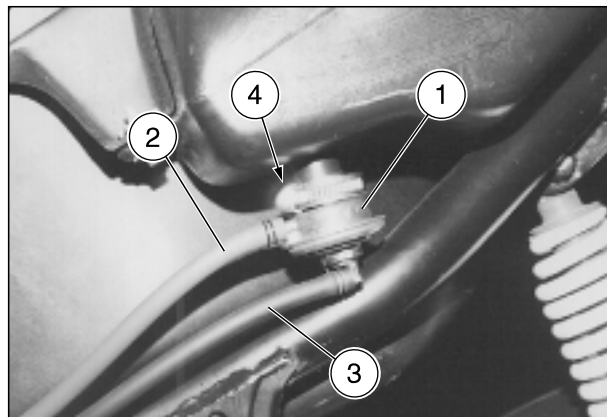

CHECKING THE FUEL LEVEL GAUGE UNIT

For the checking of the fuel level gauge unit, see p. 90 (FUEL LEVEL INDICATOR).

REMOVING THE FUEL LEVEL GAUGE UNIT

Carefully read p. 29 (FUEL TANK).

- ◆ Remove the crash helmet compartment, see p. 25 (REMOVING THE CRASH HELMET COMPARTMENT complete with saddle).
- ◆ Unscrew and remove the screw (1).
- ◆ Remove the cover (2).
- ◆ Disconnect the electric connector of the fuel level gauge unit (3).
- ◆ Unscrew and remove the four nuts and washers (4).

⚠ CAUTION

Handle with care.
Avoid damaging the gauge unit during the removal.

- ◆ Raise the fuel level gauge unit (5) and withdraw it from the tank.

⚠ WARNING

Tape the gauge unit hole on the tank shut with masking tape to avoid contaminating the tank with dust or other foreign matter.

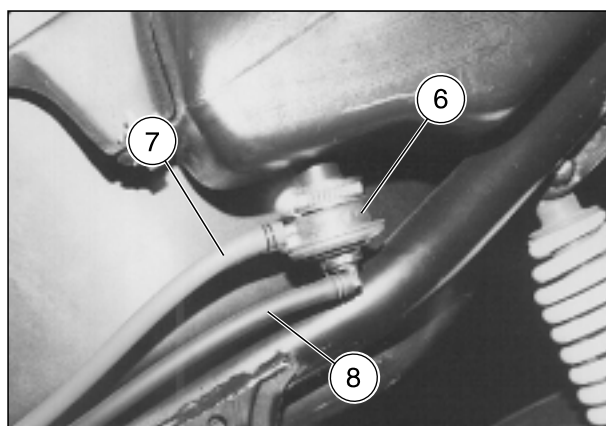
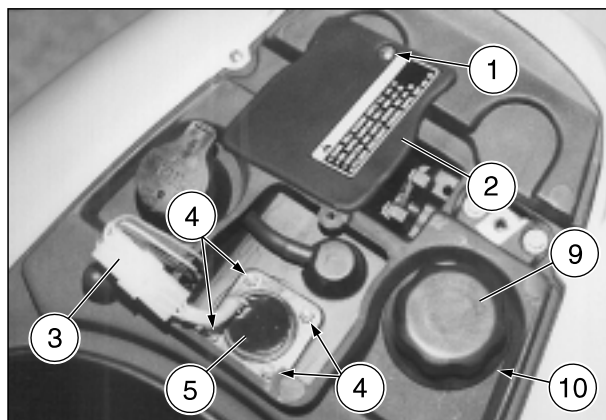

REMOVING THE COMPLETE FUEL TANK

- ◆ Drain the fuel tank completely, see p. 30 (DRAINING THE FUEL TANK).
- ◆ Put the fuel in a container, plug it and store it in a safe place.
- ◆ Disconnect the fuel hose (6) and the vacuum tube (7) from the fuel valve (8).
- ◆ Disconnect the electric connector (3) of the fuel level gauge unit (5).
- ◆ Unscrew and remove the fillercap (9).
- ◆ Withdraw and remove the rubber gasket (10).
- ◆ Unscrew and remove the three screws and washers (11).
- ◆ Partially remove the crash helmet compartment, see p. 25 (REMOVING THE CRASH HELMET COMPARTMENT complete with saddle).
- ◆ Remove the fuel tank.
- ◆ Tighten the fillercap (9).

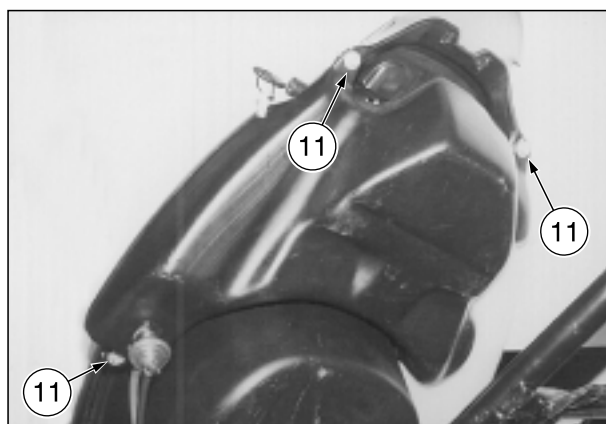

2 STROKE OIL TANK

Carefully read page 2 (GENERAL SAFETY RULES).

⚠ CAUTION

Carefully wash your hands after handling the oil.
Dispose of the oil properly.

KEEP AWAY FROM CHILDREN.

⚠ WARNING

If the 2 stroke oil runs out, the engine may seize. This may cause the overturning of the vehicle or other accidents, with consequent risk of serious injuries or even death.

CHECKING

- ◆ Check the efficiency of the oil level gauge (1), see p. 89 (CHECKING THE OIL LEVEL SENSOR).
- ◆ Check and if necessary wash the filter (2) and the filtering element with petrol, removing any deposit and impurity.

DRAINING

- ◆ Remove the rear part of the fairing, see p. 19 (REMOVING THE REAR PART OF THE FAIRING).
- ◆ Remove the tank cap (3).
- ◆ Place a container of at least 2.11 US qt (2 ℓ) capacity under the filter coupling to catch the oil.
- ◆ Cut the hose clamp (4) which attaches the hose to the filter (2) and remove.

NOTE Upon reassembly, this clamp will be replaced with a screwdriver type worm clamp of the appropriate size. This clamp may be obtained from local sources.

- ◆ Disconnect the filter (2) from the 2 stroke oil tank (5).

⚠ CAUTION

Position and fix the filter (2) vertically, so that the residual oil left in the pipe (6) cannot flow out.

- ◆ Catch the oil in the container.

REMOVAL

- ◆ Drain the 2 stroke oil tank (5) completely, see p. 33 (DRAINING).
- ◆ Disconnect the electric connectors (7) of the 2 stroke oil level gauge (1).
- ◆ Remove the tank cap (3).
- ◆ Withdraw and remove the rubber gasket (8).
- ◆ Unscrew the two screws (9) and remove them along with their washers.
- ◆ Withdraw the tank from the crash helmet compartment and remove it.

⚠ CAUTION

Upon reassembly, fill the tank and bleed the 2 stroke oil, see p. 34 (BLEEDING THE 2 STROKE OIL TANK).

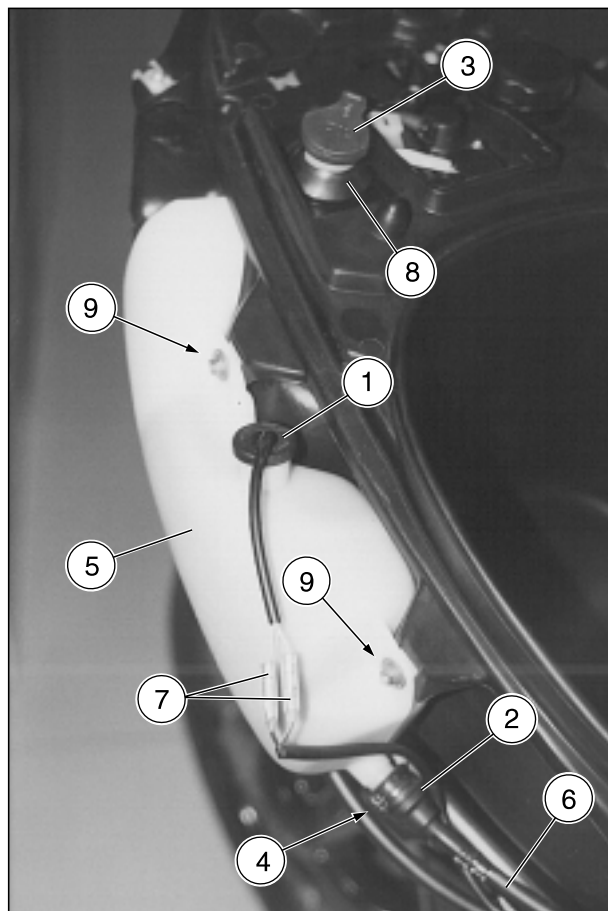



BLEEDING THE 2 STROKE OIL TANK

NOTE Bleed the 2 stroke oil system whenever the 2 stroke oil tank is completely empty or the oil supply pipe is disconnected to remove the tank.

⚠ CAUTION

Carefully wash your hands after handling the oil.
Dispose of the oil properly.

BE SURE TO KEEP THE DRAINED OIL AWAY FROM CHILDREN.

- ◆ Place the vehicle on the center stand.
- ◆ Fill the 2 stroke oil tank completely.
- ◆ Remove the exhaust silencer, see p. 73 (EXHAUST SILENCER).
- ◆ Remove the right inspection cover, see p. 20 (REMOVING THE RIGHT AND LEFT INSPECTION COVERS).
- ◆ Remove the lower shield cover, see p. 20 (REMOVING THE LOWER SHIELD COVER).
- ◆ Unscrew and remove the screw (1), the screw (2) and the screw (3).
- ◆ Remove the air conveyor (4) from its seat.
- ◆  Unscrew and remove the two screws (5).
- ◆  Unscrew and remove the three screws (6).
- ◆  Remove the pump case (7) from its seat.
- ◆ Place a container underneath the vehicle under the oil drain screw to catch all of the drained oil.
- ◆ Unscrew and remove the oil drain screw (8) and wait until the oil flows out of the hole.

⚠ CAUTION

It is important to wait until all the air has come out, since the engine running with air in the 2 stroke oil system can seriously damage the engine itself.

- ◆ When no more air bubbles can be seen in the outflowing oil, screw and tighten the oil drain screw (8).
- ◆ Check the 2 stroke oil level and top up, if necessary.

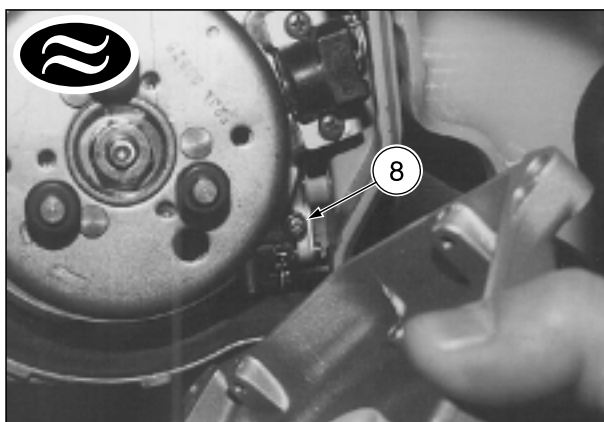
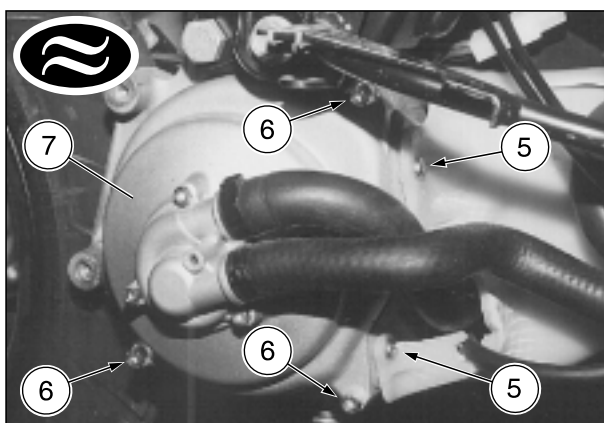
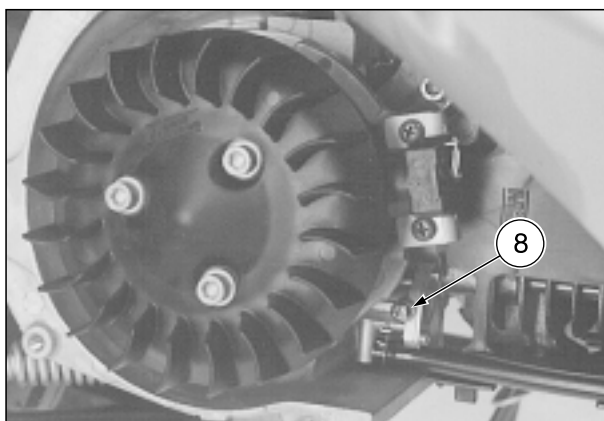
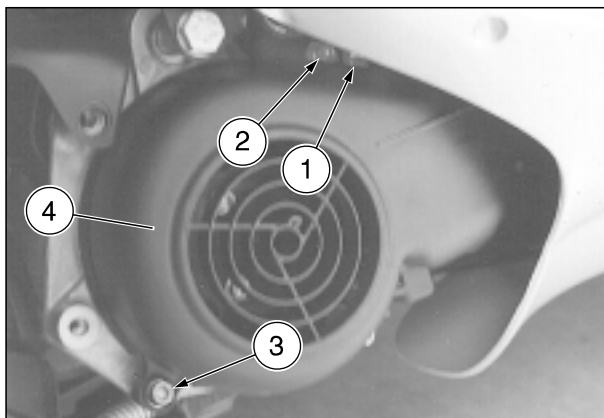

COOLING SYSTEM **COOLANT** **⚠ CAUTION**

Do not use the vehicle if the coolant is below the minimum prescribed level.

Check the coolant level every 1,250 mi (2,000 km) and after long trips; have the coolant changed by your Local aprilia Dealer every 2 years.

⚠ WARNING

Coolant is poisonous! Do not ingest coolant under any circumstance. Should you get coolant in your mouth, rinse with cool water and immediately seek medical attention. Coolant is also very dangerous to your skin and eyes. Should you accidentally get coolant on your clothing or skin, change clothes immediately. Wash coolant from your skin with hot water and soap. Should you get coolant in your eyes, flush with plenty of cool water and seek professional medical help at once. Should someone swallow coolant accidentally, induce vomiting, rinse mouth with water, and immediately seek professional medical attention.

⚠ WARNING

DISPOSE OF THE COOLANT PROPERLY.

BE SURE TO KEEP THE DRAINED COOLANT AWAY FROM CHILDREN AND PETS. IT IS SWEET TASTING, AS WELL AS EXTREMELY POISONOUS, AND IS VERY ATTRACTIVE TO CHILDREN AND PETS.

Use extra caution not to spill the coolant on any hot parts of the engine. It is flammable, and can emit invisible, noxious fumes.

Always wear rubber or latex gloves when servicing the cooling system.

The coolant is made up of 50% water and 50% anti-freeze.

This mixture is ideal for most running temperatures and ensures good protection against corrosion.

It is advisable to keep the same mixture also in the hot season, since in this way losses due to evaporation are reduced and it is not necessary to top up very frequently.

The mineral salt deposits left in the radiator by evaporated water are thus reduced and the efficiency of the cooling system remains unchanged.

If the outdoor temperature is below 0°C, check the cooling circuit frequently and if necessary increase the anti-freeze concentration (up to maximum 60%).

⚠ CAUTION

Use only distilled water when topping off the cooling system. This will reduce damage to the engine.

⚠ WARNING

The coolant is very hot.

Do not remove the filler cap (1) when the engine is hot since the coolant is under pressure and it will splash out violently.

If it gets in contact with the skin or with your clothing, it may cause severe burns.

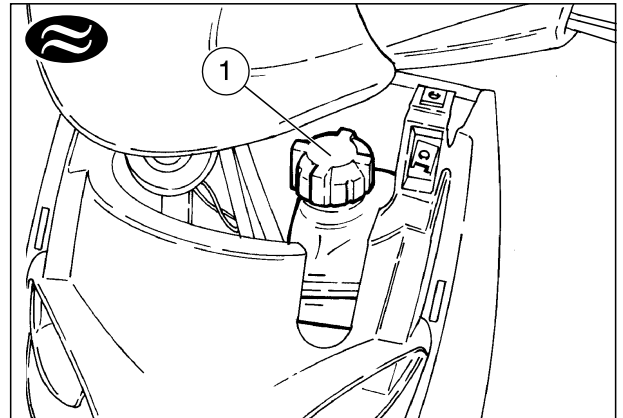

CHECKING THE COOLANT LEVEL AND TOPPING UP

Carefully read page 2 (GENERAL SAFETY RULES) and page 35 (COOLANT).

⚠ WARNING

Be aware of the risk of burns from the coolant.

Check the coolant level and top up the expansion tank only after the engine has thoroughly cooled.

NOTE Position the vehicle on firm and flat ground.

- ◆ Remove the front cover (1), see p. 25 (REMOVING THE FRONT SHIELD COVER).
- ◆ Make sure that the level of the fluid contained in the expansion tank (2) is included between the "MIN" and "MAX" marks.

MIN = minimum level.

MAX = maximum level.

If not, proceed as follows:

- ◆ Loosen the filler cap (3) (by giving it half counterclockwise turn), without removing it.
- ◆ Wait a few seconds in order to release any residual pressure that may be present in the circuit.
- ◆ Unscrew and remove the filler cap (3).

⚠ WARNING

Coolant is poisonous! Do not ingest coolant under any circumstance. Should you get coolant in your mouth, rinse with cool water and immediately seek medical attention. Coolant is also very dangerous to your skin and eyes. Should you accidentally get coolant on your clothing or skin, change clothes immediately. Wash coolant from your skin with hot water and soap. Should you get coolant in your eyes, flush with plenty of cool water and seek professional medical help at once. Should someone swallow coolant accidentally, induce vomiting, rinse mouth with water, and immediately seek professional medical attention.

⚠ WARNING

Do not use your fingers or any other object to check if there is enough coolant.

- ◆ Top up with coolant, see p. 11 (LUBRICANT CHART) until the coolant level reaches approximative the "MAX" notch. Do not exceed this level, otherwise the coolant will flow out while the engine is running.
- ◆ Replace the filler cap (3).

⚠ CAUTION

If an excessive amount of coolant is consumed, or if the expansion tank remains empty, check for leaks in the cooling system.

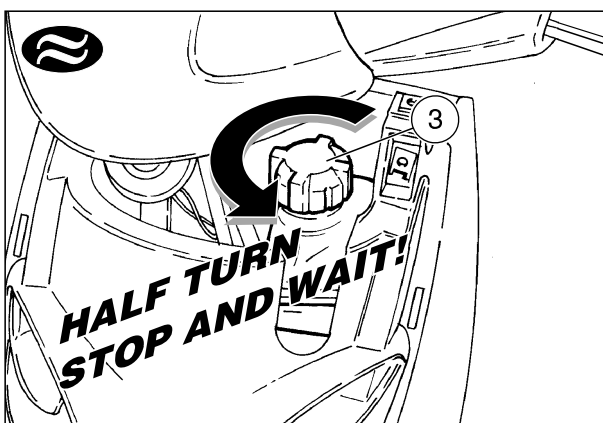
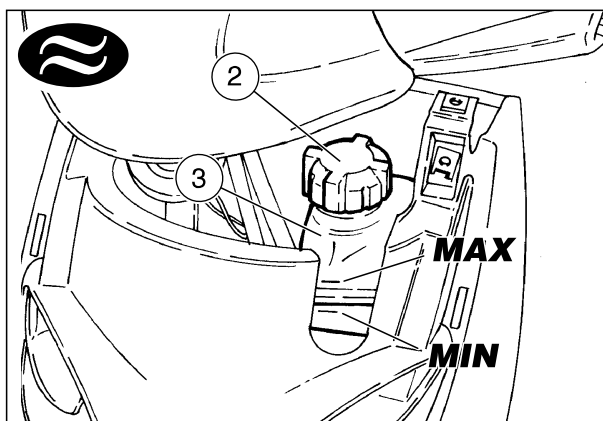
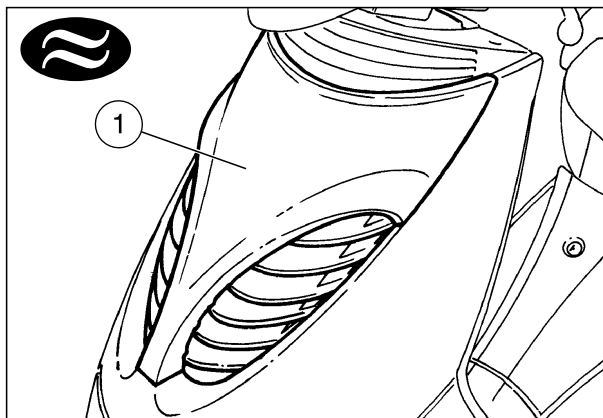

DRAINING THE COOLANT SYSTEM

Carefully read page 2 (GENERAL SAFETY RULES) and page 35 (COOLANT ).

WARNING

Stop the engine and wait until the engine and the exhaust system have cooled down.

- ◆ Place the vehicle on the center stand.
- ◆ Remove the front cover (1), see p. 21 (REMOVING THE FRONT COVER).

WARNING

Do not remove the expansion tank cap when the engine is hot, since the coolant is under pressure and its temperature is high. If it gets in contact with the skin or with clothes, it may cause severe burns and/or damages.

Proceed with care, releasing any residual pressure that may be present in the system.

- ◆ Unscrew and remove the filling cap (3) from the expansion tank (2).
- ◆ Put a container with at least 1.2 ℓ capacity under the hose fitting (4).
- ◆ Remove the original equipment clamp by cutting it with diagonal cutters or a tin snip.
- ◆ Remove the hose (4) and let the coolant drain completely.
- ◆ Store the coolant in a tightly closed container.

WARNING

DISPOSE OF THE COOLANT PROPERLY. BE SURE TO KEEP THE DRAINED COOLANT AWAY FROM CHILDREN AND PETS. IT IS SWEET TASTING, AS WELL AS EXTREMELY POISONOUS, AND IS VERY ATTRACTIVE TO CHILDREN AND PETS.

Use extra caution not to spill the coolant on any hot parts of the engine. It is flammable, and can emit invisible, noxious fumes.

Always wear rubber or latex gloves when servicing the cooling system.

NOTE Obtain screwdriver type worm gear hose clamp to replace the removed original equipment clamp.

- ◆ Replace the clamp (5) with a new clamp.
- ◆ Reconnect the hose (4) to the lower coupling of the coolant pump.
- ◆ Tighten the new hose clamp.

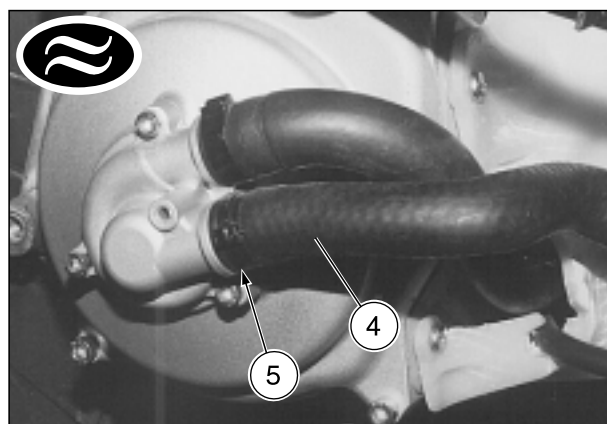
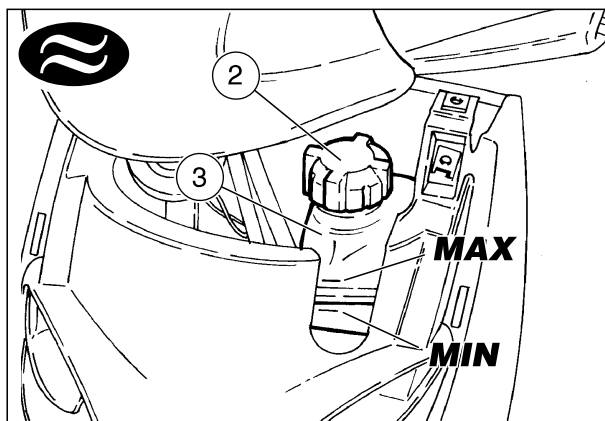
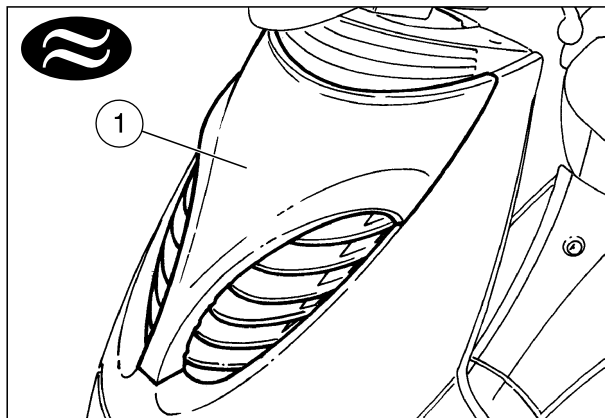

CHANGING THE COOLANT

Carefully read page 2 (GENERAL SAFETY RULES) and page 35 (COOLANT ).

CAUTION

Do not use the vehicle if the coolant is below the minimum prescribed level.

- ◆ Drain the cooling system, see p. 37 (DRAINING THE COOLANT SYSTEM ).
- ◆ Put 1.1 ℓ of coolant in the expansion tank (1), see p. 11 (LUBRICANT CHART).
- ◆ Top up until the coolant reaches the “MAX” level approximately.
- ◆ Do not exceed this level, otherwise the coolant will overflow while the engine is running.
- ◆ Replace the filler cap (2).

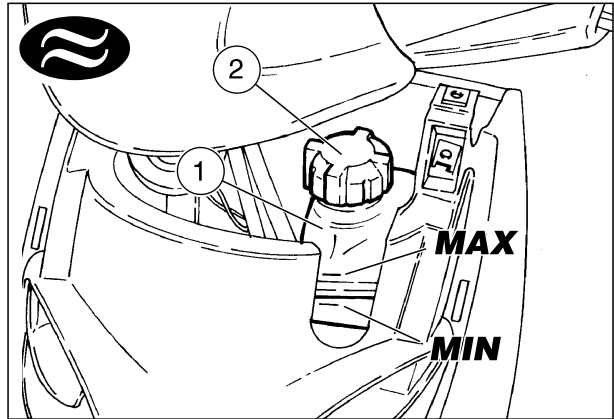

BLEEDING THE COOLANT SYSTEM

Carefully read page 2 (GENERAL SAFETY RULES) and page 35 (COOLANT )

- ◆ Check the coolant level, see p. 36 (CHECKING THE COOLANT LEVEL AND TOPPING UP )
- ◆ Remove the right inspection cover, see p. 20 (REMOVING THE RIGHT AND LEFT INSPECTION COVERS).

WARNING

Exhaust gas is poisonous! Do not let the engine run in closed or poorly ventilated spaces. Failure to heed this warning can lead to serious injury or death. See the General Safety Rules on p.1.

- ◆ Start the engine and let it idle.
- ◆ Put a container under the engine to collect the coolant that flows out of the air screw (1).

WARNING

The coolant is under pressure, therefore loosen the engine head air screw (1) slowly and carefully in order to avoid dangerous splashes.

- ◆ Loosen the engine head air screw (1); let a small quantity of coolant and any air bubble flow out, then tighten the engine head air screw (1).

NOTE For the vehicles provided with warmed carburetor, carry out the operations marked with “★”.

- ◆ ★ Remove the plug (2); let a small quantity of coolant and any air bubbles flow out, then replace the plug (2).

- ◆ Check the coolant level in the expansion tank (3) and top up until it reaches the “MAX” mark. Do not exceed this level, otherwise the coolant will overflow while the engine is running.
- ◆ Replace the right inspection cover, see p. 20 (REMOVING THE RIGHT AND LEFT INSPECTION COVERS).
- ◆ Replace the front cover (4), see p. 21 (REMOVING THE FRONT COVER).

WARNING

If an excessive amount of coolant is consumed, or if the expansion tank remains empty, check for leaks in the cooling system.
The coolant is noxious: DO NOT SWALLOW.

DO NOT DISPOSE OF THE COOLANT IN THE ENVIRONMENT.

KEEP AWAY FROM CHILDREN.

CAUTION

Use only antifreeze and anticorrosive without nitrite, ensuring protection at -35 °C at least.

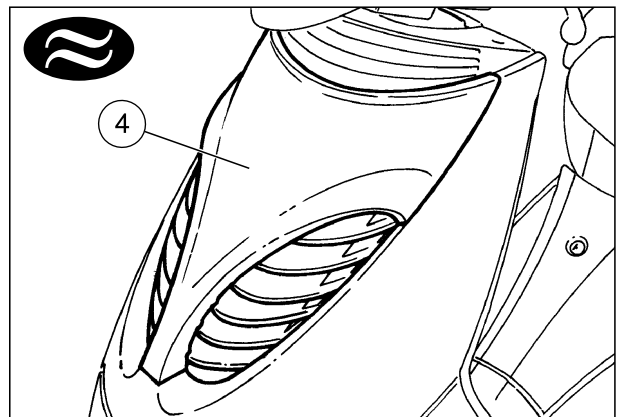
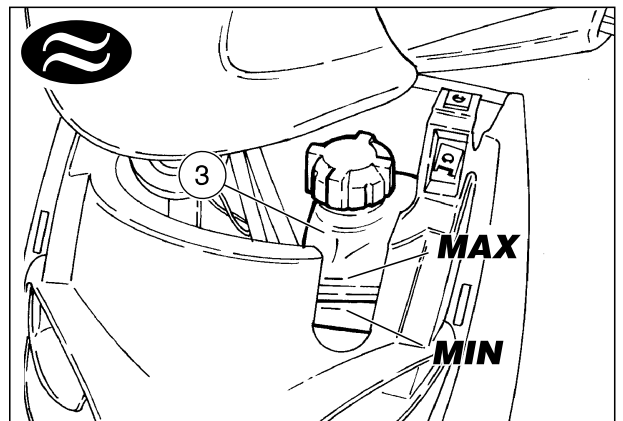
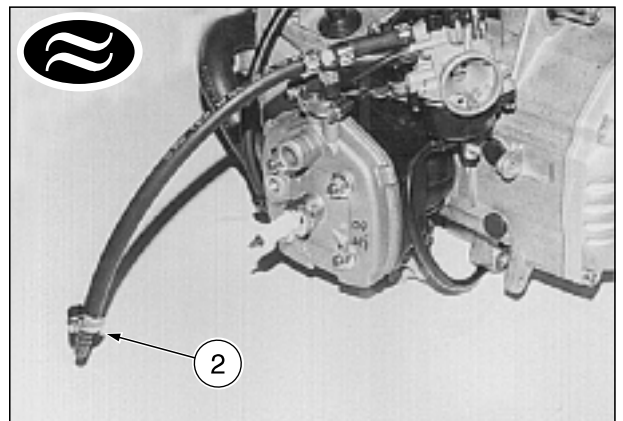
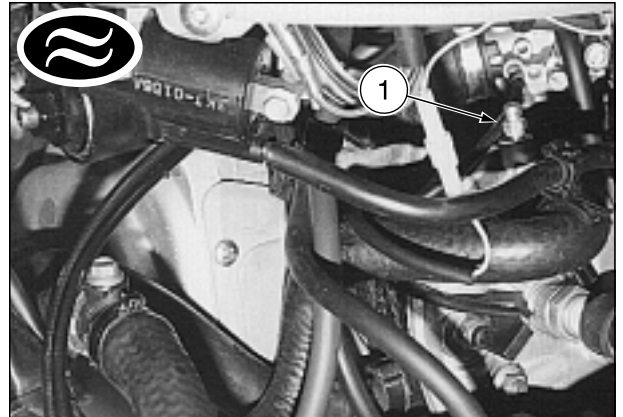

REMOVING THE RADIATOR

Carefully read page 2 (GENERAL SAFETY RULES) and p. 35 (COOLANT ).

- ◆ Drain the coolant completely, see p. 37 (DRAINING THE COOLANT SYSTEM ).
- ◆ Partially remove the front outer shield, see p. 28 (REMOVING THE FRONT OUTER SHIELD).

NOTE Obtain screwdriver type worm gear hose clamp to replace the removed original equipment clamp.

- ◆ Cut the band of the hose clamps (1), (2), (3) and (4).

NOTE Upon reassembly, replace the hose clamps (1), (2), (3) and (4) with new ones.

- ◆ Withdraw the following elements from the radiator couplings:
 - delivery hose (5);
 - return hose (6);
 - breather hose (7);
 - sleeve (8).
- ◆ ★ Unscrew and remove the two screws (9).

CAUTION

Proceed with care.
Do not damage the radiator fins.

- ◆ Remove the radiator (10).

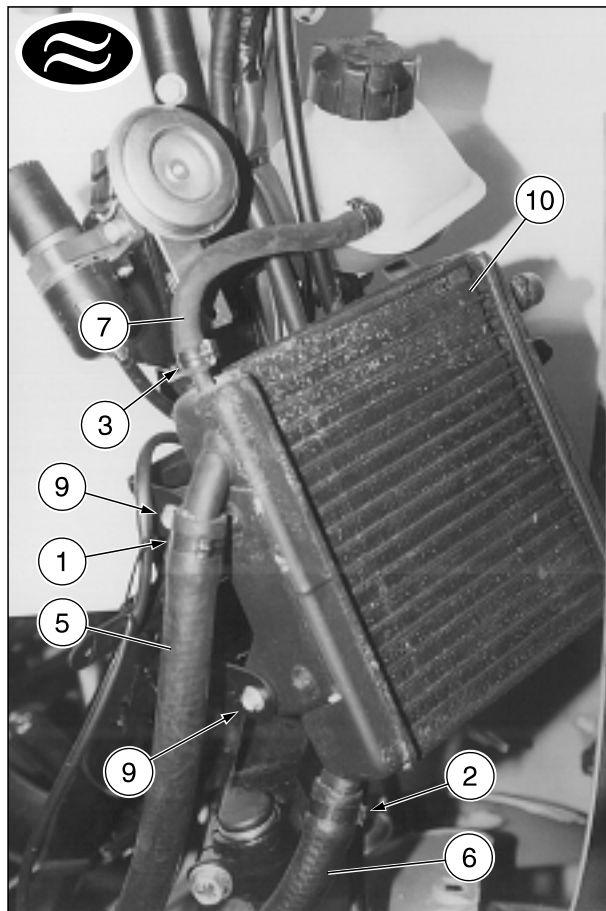

REMOVING THE COOLANT PUMP

- ◆ Drain the cooling system, see p. 37 (DRAINING THE COOLANT SYSTEM ) (excluding the last four operations).

NOTE Obtain screwdriver type worm gear hose clamp to replace the removed original equipment clamp.

- ◆ Cut the clamp head (11).

NOTE Upon reassembly, replace the clamp (11) with a new one.

CAUTION

Mark the hose (12) in order to avoid any confusion during the reassembly.

- ◆ Remove the hose (12) from the pump coupling.
- ◆ Remove the coolant pump, see ENGINE SERVICE AND REPAIR MANUAL # 921 (I-UK-F-D-E).

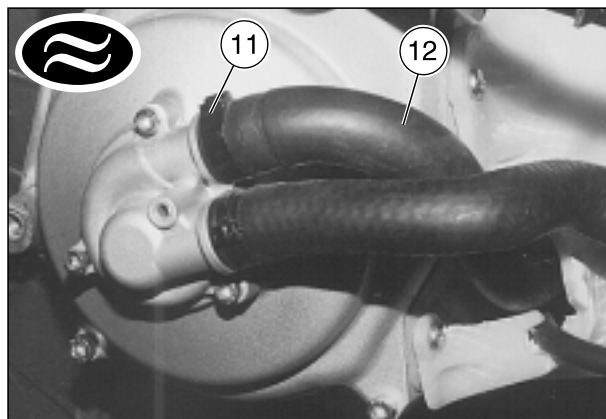
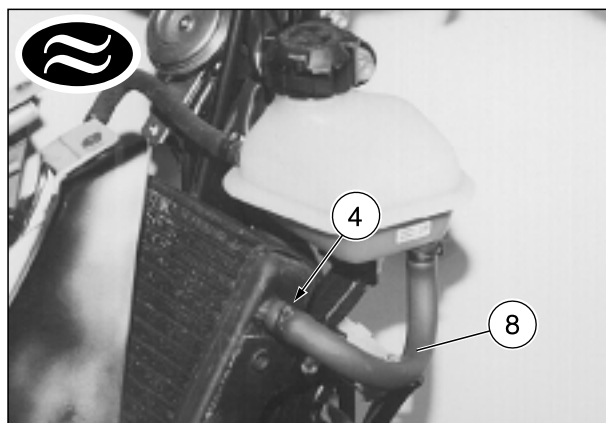

REMOVING THE EXPANSION TANK

Carefully read page 2 (GENERAL SAFETY RULES) and p. 35 (COOLANT ).

- ◆ Place the vehicle on the center stand.
- ◆ Remove the front inner shield, see p. 22 (REMOVING THE FRONT INNER SHIELD).
- ◆ Remove the front cover, see p. 21 (REMOVING THE FRONT COVER).

CAUTION

By withdrawing the sleeve (1), you will make the coolant flow out of the expansion tank (2).

Prepare a container with about 1 ℓ capacity to gather the outflowing coolant.

Put a cloth under the expansion tank, to absorb the coolant that may drip on the floor.

NOTE Obtain screwdriver type worm gear hose clamps to replace the removed original equipment clamps.

- ◆ Cut the head of the clamp (3).

NOTE Upon reassembly, replace the clamp with a new one.

- ◆ Withdraw the sleeve (1) from the expansion tank coupling.
- ◆ Promptly put the container under the expansion tank and gather the coolant.

WARNING

DISPOSE OF THE COOLANT PROPERLY. BE SURE TO KEEP THE DRAINED COOLANT AWAY FROM CHILDREN AND PETS. IT IS SWEET TASTING, AS WELL AS EXTREMELY POISONOUS, AND IS VERY ATTRACTIVE TO CHILDREN AND PETS.

Use extra caution not to spill the coolant on any hot parts of the engine. It is flammable, and can emit invisible, noxious fumes.

Always wear rubber or latex gloves when servicing the cooling system.

- ◆ Cut the head of the clamp (4).

NOTE Upon reassembly, replace the clamp with a new one.

- ◆ Withdraw the breather pipe (5) from the expansion tank coupling.
- ◆ Unscrew and remove the two screws (6), taking the washers.
- ◆ Remove the expansion tank (2).

REMOVING THE COOLANT TEMPERATURE TERMISTOR

- ◆ Drain the cooling system, see p. 37 (DRAINING THE COOLANT SYSTEM ).
- ◆ Remove the right inspection cover, see p. 20 (REMOVING THE RIGHT AND LEFT INSPECTION COVERS).
- ◆ Disconnect the terminal (7) (white/blue (Bi/B) cable) from the thermistor (8).
- ◆ Remove the thermistor (8), see ENGINE SERVICE AND REPAIR MANUAL # 921 (I-UK-F-D-E).

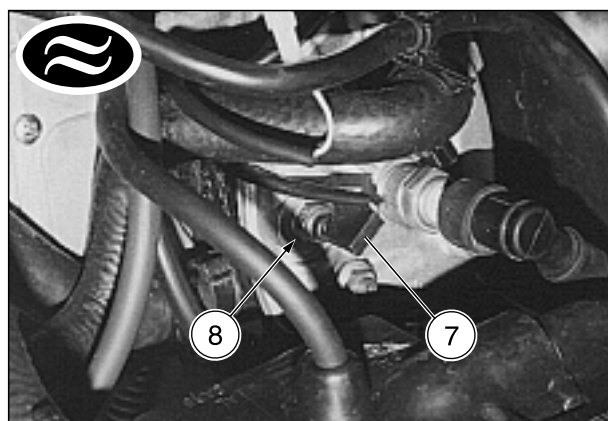
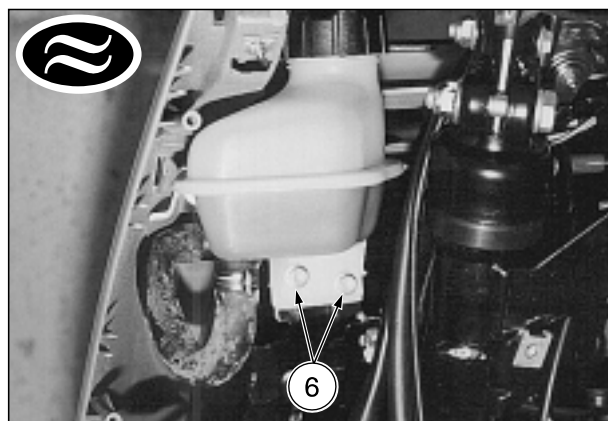
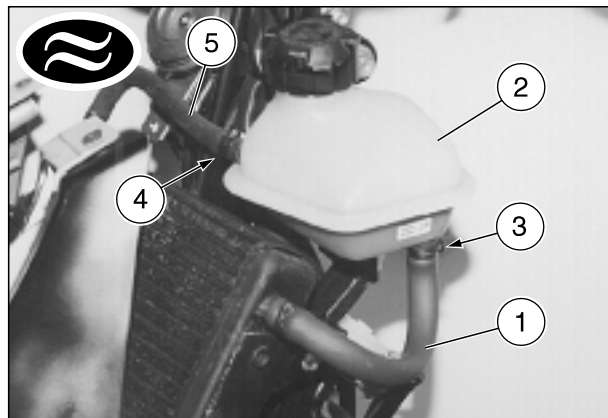

BULBS

Carefully read page 2 (GENERAL SAFETY RULES).

⚠ WARNING

Risk of fire.

Keep fuel and other flammable substances away from the electrical components.

⚠ CAUTION

Before changing a bulb, turn the ignition switch to position "⊗" (OFF) and wait a few seconds in order to allow the bulb to cool down.

Change the bulb wearing clean gloves or using a clean and dry cloth.

Do not leave fingerprints on the bulb, since these may cause its overheating and consequent breakage.

If you touch the bulb with bare hands, remove any fingerprints with alcohol, in order to prevent it from blowing.

TAKE CARE TO AVOID DAMAGING THE ELECTRIC CABLES.

HEADLIGHT**ADJUSTING THE HEADLIGHT BEAM VERTICALLY****⚠ WARNING**

Do not use the vehicle if the lights are not functioning properly.

Do not use the vehicle if the headlight is adjusted incorrectly. This could temporarily blind oncoming cars, and also reduce the rider's ability to see any obstacle along the road while riding at night.

It is always advisable to reduce speed when riding during the night, in such a way as to have the time necessary to avoid any obstacle and to adapt to the poorer visibility that inevitably results from darkness. Failure to observe this warning can cause you to collide with another object, with consequent risk of serious injury or even death.

NOTE The procedure described here is in compliance with the Italian standard that establishes the maximum height of the headlight beam.

For vehicles used in other countries, you must conform with the local regulations.

To rapidly check the correct direction of the beam, place the vehicle on flat ground, **32.81 ft (10 m)** away from a wall.

Turn on the low beam, sit on the vehicle and make sure that the beam projected on the wall is slightly under the horizontal line of the headlight (about 9/10th of the total height).

To adjust the headlight beam:

- ◆ Adjust screw (1) by means of a screwdriver.
 - By **SCREWING IT** clockwise you adjust the beam higher.
 - By **UNSCREWING IT** counterclockwise you adjust the beam lower.

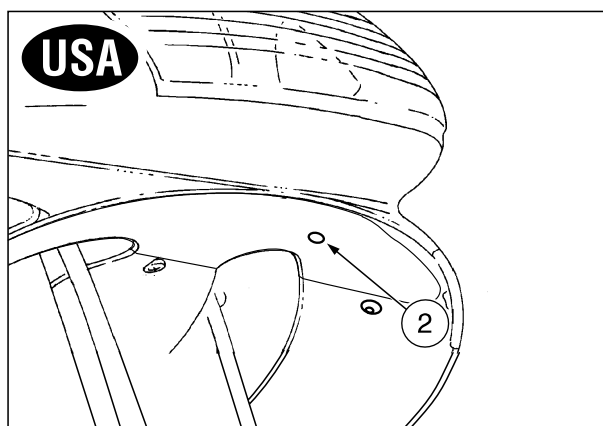
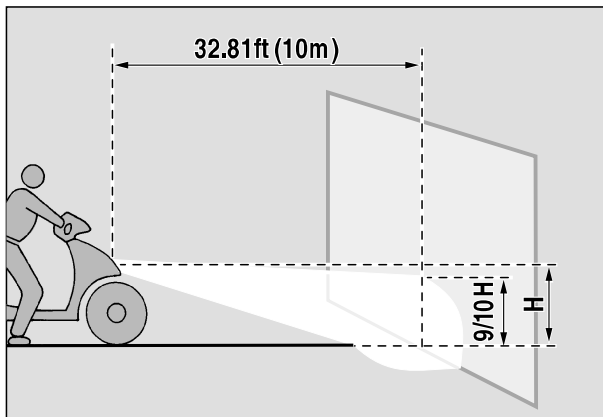

ADJUSTING THE HEADLIGHT BEAM HORIZONTALLY

NOTE The terms “right” and “left” are referred to the rider seated on the vehicle in the normal riding position.

It is possible to adjust the horizontal position both to the right and to the left.

The figures (B excluded) refer to the rightward position.

The adjustment is carried out using shims and adjusting screws which are supplied as a kit. They will be found in the crash helmet / glove compartment.

To adjust the beam:

- ◆ Remove the front shield cover, see p. 25 (REMOVING THE FRONT SHIELD COVER).
- ◆ Remove the front inner shield, see p. 22 (REMOVING THE FRONT INNER SHIELD).
- ◆ Unscrew and remove the screw (1).
- ◆ Unscrew and remove the screws (2).

⚠ CAUTION

Handle with care.
Take care not to damage the electric wires.

- ◆ Loosen the headlight (3).
- There are four groups of shims, for four different degrees of adjustment.

Each shim is marked with the type identification code (for example: UPPER PIV.) and with the group number (for example: 3°) (see table below).

Adjustment degree				
Group	1°	2°	3°	4°
Shim	UPPER PIV. 1°	UPPER PIV. 2°	UPPER PIV. 3°	UPPER PIV. 4°
Screw	4,2 x 20	4,2 x 20	4,2 x 20	4,2 x 20
Shim	UPPER OUT 1°	UPPER OUT 2°	UPPER OUT 3°	UPPER OUT 4°
Screw	4,2 x 20	4,2 x 25	4,2 x 25	4,2 x 30
Shim	LOWER 1°	LOWER 2°	LOWER 3°	LOWER 4°
Screw	4,2 x 20	4,2 x 25	4,2 x 25	4,2 x 30

Depending on the beam adjustment to be carried out, select:

- the group necessary for the adjustment;
- the direction (to the right or to the left).

NOTE Use shims and screws of the same group.

- ◆ Insert the shims in the headlight screw seats as indicated in figures A and B:
 - rightwards (figure A);
 - leftwards (figure B).

- ◆ Position the headlight (3) in its seat.
- ◆ Screw and tighten finger tight the lower left screw (1) (in the seat without shim).

NOTE Replace the screws (2) with the specific screws corresponding to each shim.

Take the screws (2) and keep them in the kit.

- ◆ Screw and tighten finger tight the three screws (specific for each shim) (see table).
- ◆ Tighten the four screws.
- ◆ Make sure that the horizontal adjustment of the headlight beam is correct.
- ◆ Replace the front inner shield, see p. 22 (REMOVING THE FRONT INNER SHIELD).
- ◆ Replace the front shield cover, see p. 25 (REMOVING THE FRONT SHIELD COVER).
- ◆ Make sure that the vertical adjustment of the headlight beam is correct, see p. 42 (ADJUSTING THE HEADLIGHT BEAM VERTICALLY).

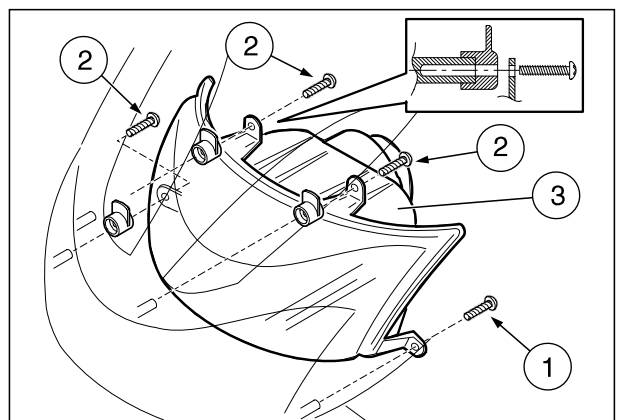
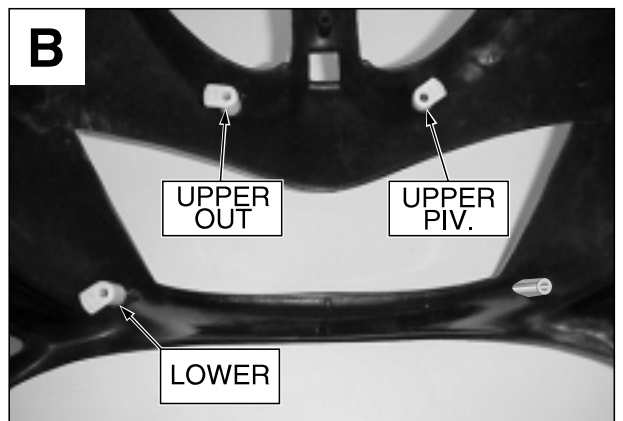
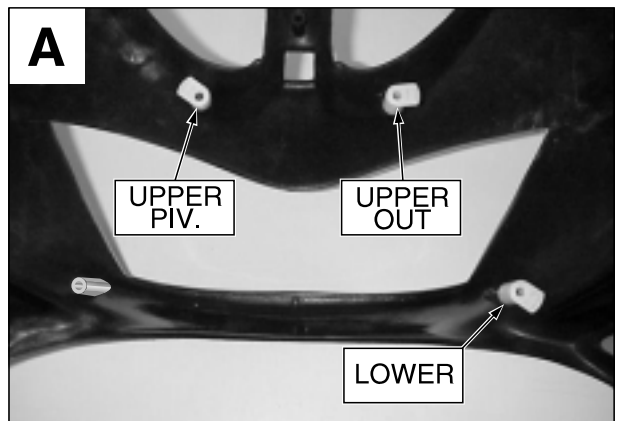
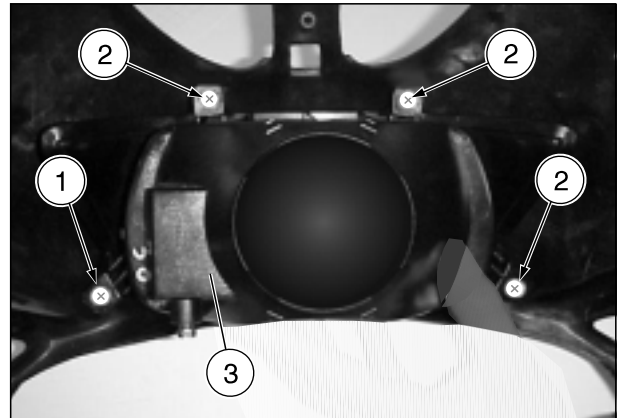

CHANGING THE HEADLIGHT BULBS

Carefully read p. 42 (BULBS).

The headlight contains:

- one parking light bulb (1);
- one low/high beam bulb (2).

To change the bulbs:

PARKING LIGHT BULB

- ◆ Remove the front inner shield, see p. 22 (REMOVING THE FRONT INNER SHIELD).

CAUTION

While removing a bulb socket, do not pull on the wires.

Grasp the bulb socket (3), pull it and remove it from its seat.

- ◆ Remove the parking light bulb (1) and replace it with an identical bulb.

LOW/HIGH BEAM BULB

- ◆ Remove the front inner shield, see p. 22 (REMOVING THE FRONT INNER SHIELD).
- ◆ Pull back the rubber boot (4) with your fingers.
- ◆ Rotate the bulb socket (5) counterclockwise and remove it.
- ◆ Push the bulb (2) toward the back of the socket lightly, and rotate it counterclockwise.
- ◆ Remove the bulb from the seat.

NOTE Be sure to maintain the same orientation as the old bulb when you install the new bulb. Do not force the bulb, it will go easily if it is properly oriented.

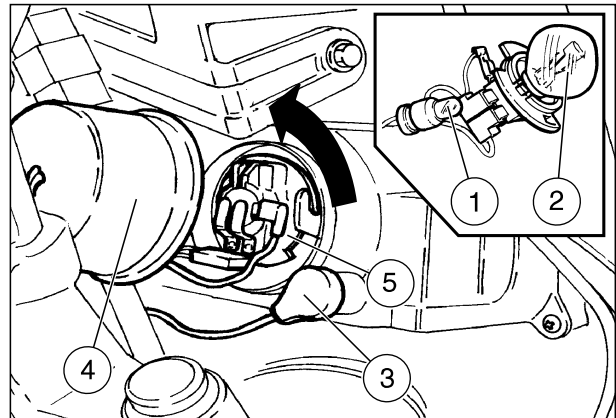

REMOVING THE HEADLIGHT

- ◆ Remove the front inner shield, see p. 22 (REMOVING THE FRONT INNER SHIELD).
- ◆ Unscrew and remove the three screws (1).
- ◆ ★ Pull the rubber boot (2) back out of the way with your hands.
- ◆ ★ Disconnect the electric connectors (3).
- ◆ ★ Unscrew and remove the two screws (4).

NOTE To facilitate this operation, steer the front wheel to the left and work on the left side.

⚠ CAUTION

Handle with care.
Do not damage the protection screen.

- ◆ Remove the headlight (5) complete with bulb socket by withdrawing it from behind.

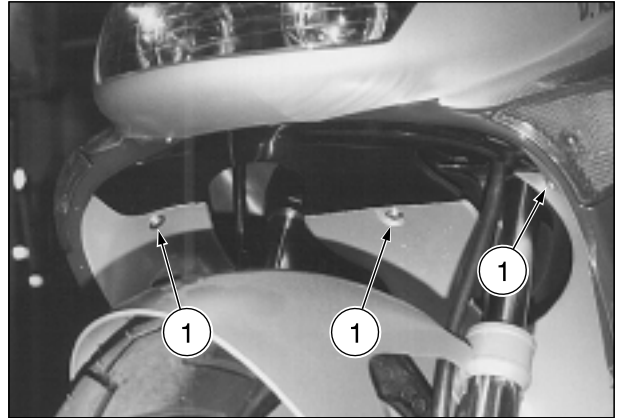

FRONT AND REAR DIRECTION INDICATORS

CHANGING THE BULB

Carefully read p. 42 (BULBS).

NOTE Before changing a bulb, check the fuse.

- ◆ Place the vehicle on the center stand.
- ◆ Unscrew and remove the screw (6).

NOTE While removing the lens, use extra care to be sure that you do not break the key.

- ◆ Remove the lens (7).

NOTE Upon reassembly, position the lens correctly in its seat.

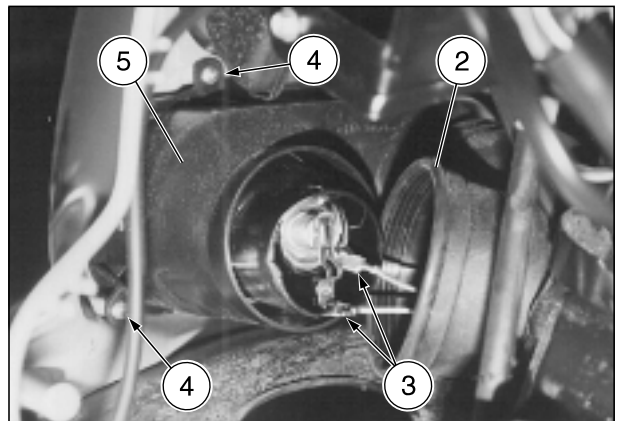

⚠ CAUTION

Tighten the screw (6) moderately and with care to avoid damaging the lens.

- ◆ Push the bulb (8) in slightly and rotate it counterclockwise.
- ◆ Extract the bulb from its seat.

NOTE Insert the bulb in the bulb socket, carefully aligning the two bulb pins with their guides in the socket.

- ◆ Correctly install a new bulb of the same type.

NOTE If the bulb socket (9) has fallen out of its seat, replace it correctly, ensuring that the slot in the reflector aligns with the screw hole in the body of the turn signal lamp.

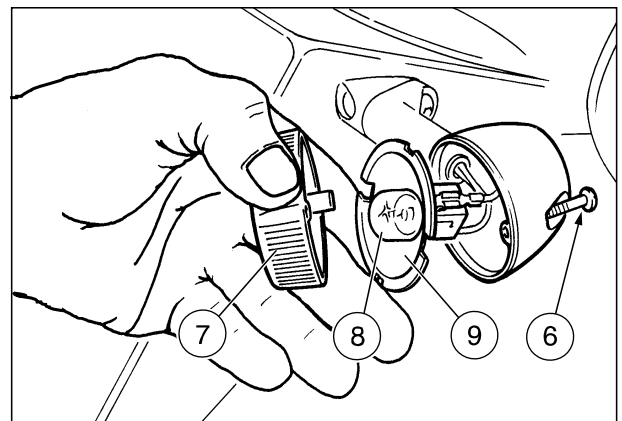

REAR LIGHT

CHANGING THE BULBS

Carefully read p. 42 (BULBS).

⚠ WARNING

Do not ride your vehicle if the tail light and the stoplight are not working properly. The stoplight is particularly important to prevent other vehicles from rearending you. Obviously, failure to comply with these instructions could lead to a serious accident with subsequent injuries or even death.

NOTE Before changing a bulb, check the fuse, also check the operation of the stoplight switches.

The rear light comprises two units. Each unit contains:

- one parking light bulb (1);
- one stoplight bulb (2).

To change them, proceed as follows:

- ◆ Place the vehicle on the center stand.
- ◆ Unscrew and remove the screw (3).

NOTE While removing the lens, use extra care to be sure that you do not break the key.

- ◆ Remove the lens (4).

NOTE Upon reassembly, position the lens correctly in its seat.

⚠ CAUTION

Tighten the screw (3) moderately and with care to avoid damaging the lens.

- ◆ **Only for the stoplight bulb:** push the bulb in slightly and rotate it counterclockwise.
- ◆ Extract the bulb from its seat.

NOTE Insert the bulb in the bulb socket, carefully aligning the two bulb pins with their guides in the socket.

- ◆ Correctly install a new bulb of the same type.

REMOVING THE REAR LIGHT

NOTE The rear light consists of two units.

The following operations refer to one unit only.

- ◆ Remove the number plate-holder, see p. 19 (REMOVING THE NUMBER PLATE-HOLDER).
- ◆ Unscrew and remove the two screws (5).

⚠ CAUTION

Handle with care.

Do not force the electric cables.

- ◆ Partially remove the unit (6).
- ◆ Disconnect the brake light bulb terminals (7).

⚠ CAUTION

To extract the bulb socket, do not pull the electric cables.

- ◆ Grasp the parking light bulb socket, pull and remove it from its seat.
- ◆ Remove the unit (6).

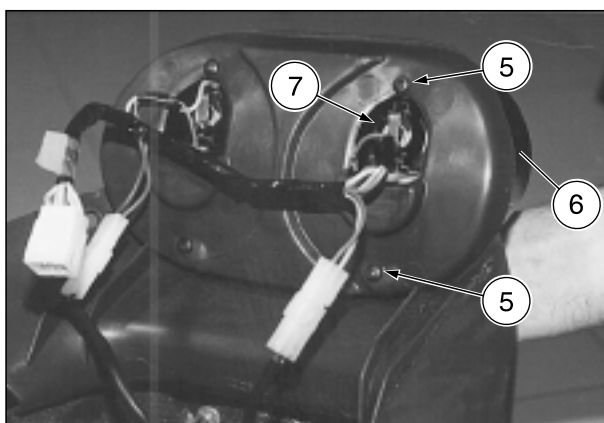
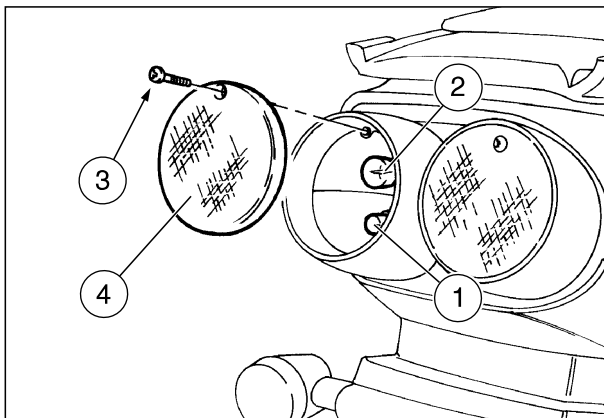

CHANGING THE LICENSE PLATE BULB

Carefully read p. 42 (BULBS).

To change the bulb:

CAUTION

While removing a bulb socket, do not pull on the wires.

- ◆ Grasp the bulb socket (1) from the inside of the rear part of the fairing cover, pull it and remove it from its seat.
- ◆ Remove the bulb (2) and replace it with an identical bulb.

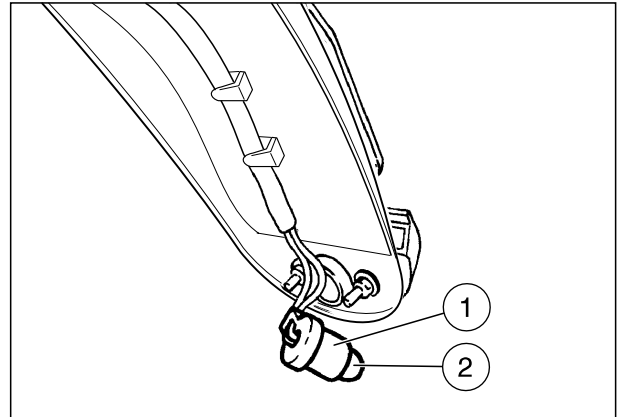

DASHBOARD

CHANGING THE BULBS

Carefully read page 42 (BULBS).

NOTE Before changing a bulb, check the fuses.

The dashboard contains:

- the warning light bulbs;
- the dashboard lighting bulbs.

To change the bulbs:

- ◆ Partially remove the upper handlebar cover, see 24 (PARTIAL REMOVAL OF THE UPPER HANDLEBAR COVER).

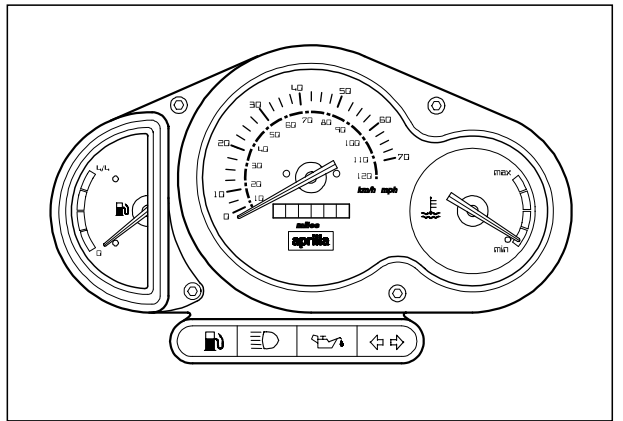

WARNING LIGHT BULBS

NOTE Extract the bulb sockets one by one, in such a way as to avoid positioning them incorrectly during the re-assembly.

- ◆ Extract the relative bulb socket:

Pos	Warning light	Colour
3	Direction indicators (↔)	green
4	2 stroke oil reserve (⚡)	red
5	High beam (≡D)	blue
6	Low fuel (⛽)	amber

- ◆ Extract the bulb and replace it with one of the same type.

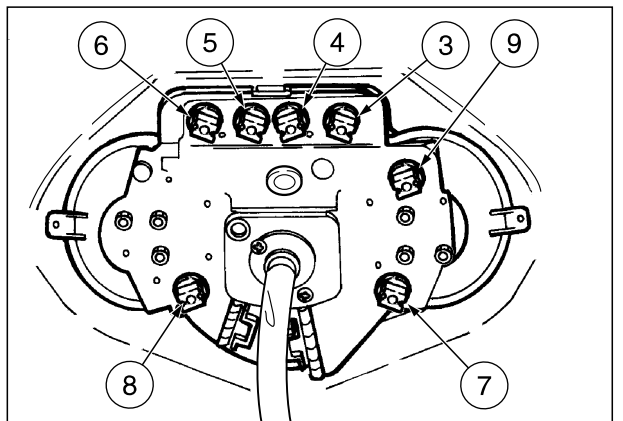

DASHBOARD LIGHTING BULBS

NOTE Extract the bulb sockets one by one, in such a way as to avoid positioning them incorrectly during the re-assembly.

- ◆ Extract the bulb socket of the dashboard part in which there has been a light decrease:

Pos.	Lit part
7	Upper right part
8	Upper left part
9	Lower right part

- ◆ Extract the bulb and replace it with one of the same type.

REMOVING THE COMPLETE DASHBOARD

- ◆ Unscrew and remove the four screws (1) that fasten the dashboard frame (2).
- ◆ Remove the handlebar cover, see p. 24 (REMOVING THE LOWER HANDLEBAR COVER).
- ◆ Disconnect the two electric connectors (3) and (4).
- ◆ Disconnect the speedometer/odometer cable (5) from the dashboard.
- ◆ Unscrew and remove the two screws (6).
- ◆ Remove the complete dashboard (7).

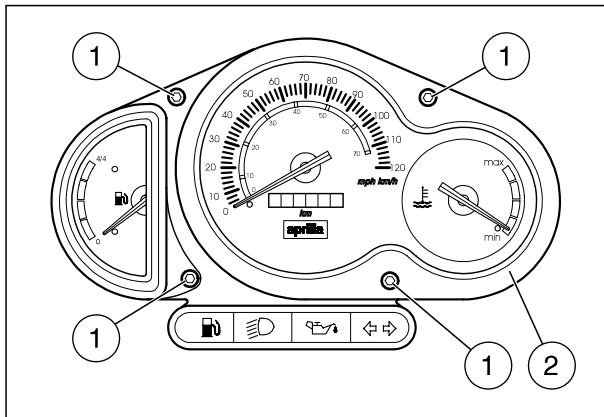

REMOVING THE DASHBOARD GLASS

CAUTION

Handle with care.
Do not damage the glass or the tabs during the disassembly.

- ◆ Press on the two tabs (8) and remove the glass (9).
- NOTE** If necessary, extract the dashboard glass gasket (10) and change it.

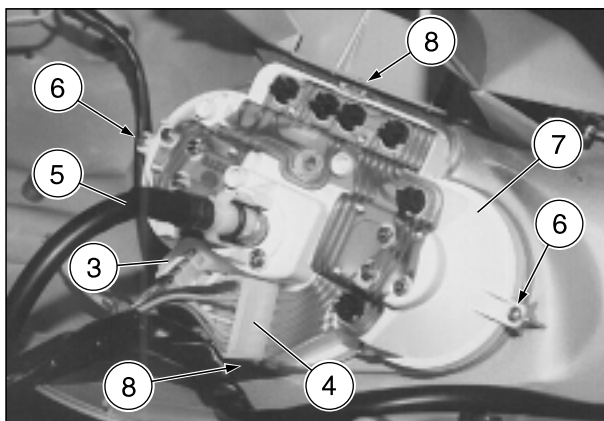

ELECTRIC CONTROL SUPPORTS

REMOVING THE HANDLEBAR CONTROLS

- ◆ Remove the handlebar cover, see p. 24 (REMOVING THE LOWER HANDLEBAR COVER).

NOTE The operations described refer to the removal of one support only.

CAUTION

Mark the electric connectors, on the side on which you are working, in order to be able to reconnect them correctly.

Side	Pos.	Description
left	A	Horn push button (📣)
	B	Direction indicator switch (↔)
	B	Dimmer switch (🔍 - 🔍)
right	C	Starter button (🔌)
	D	Engine stop switch (🛑 - 🛑)

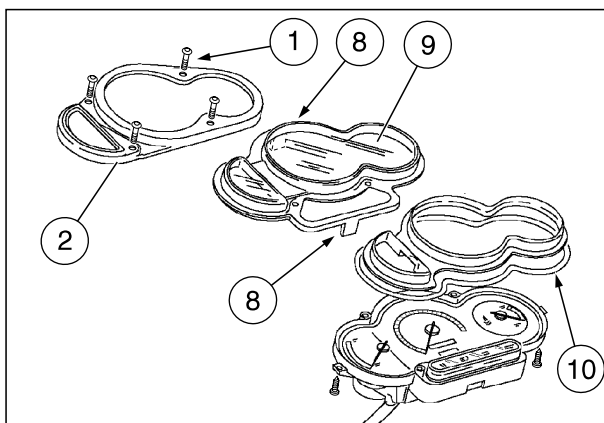

- ◆ Disconnect the two electric connectors (on the side on which you are working).
- ◆ Unscrew and remove the two screws (11).
- ◆ Remove the electric control support complete with controls.

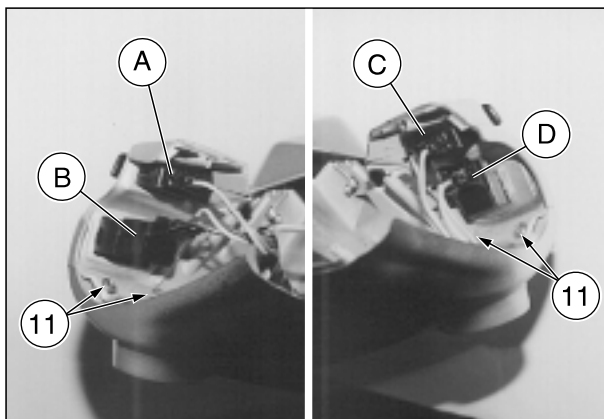

BRAKES**⚠ WARNING**

Do not ride your vehicle with worn or malfunctioning brakes! The brakes are the most important safety system of your vehicle, and using the bike with brakes that are anything less than perfect is very likely to lead to a collision or upset, with consequent risk of serious injury or death.

Check the brake pad wear, as shown on pag. 61 (CHECKING WEAR OF THE BRAKE PADS).

Ⓞ Check the brake shoe wear, as shown on p. 63 (CHECKING THE SHOE WEAR Ⓞ).

⚠ WARNING

Wet conditions seriously degrade the performance of your brakes. When the road is wet from rain, you should plan to use double the normal stopping distances since both the brakes themselves and the traction of the tires on the road are reduced by the presence of water.

Water on the brakes from washing your vehicle, or splashed up from wet roads, or crossing puddles or ditches, can wet the brakes sufficiently to greatly reduce their effectiveness. Failure to heed these warnings may lead to a serious accident with consequent risk of serious injury or even death.

NOTE This vehicle is equipped with front and rear disc brakes with separate hydraulic systems.

The following information may refer to just one braking system but should be observed with regard to both brakes.

NOTE Ⓞ For the version with rear drum brake Ⓞ, the following information refers to the front disc brake only.

⚠ WARNING

The brakes are extremely important for your safety. Do not use the vehicle if the brakes do not work perfectly. Always check the brake efficiency before riding.

⚠ WARNING

Pay special attention to the brake disc and friction material, making sure that they are neither dirty nor oily, especially after maintenance operations or inspections.

Check the brake line, make sure that it is not twisted or kinked, nor leaking.

KEEP AWAY FROM CHILDREN.

DISPOSE OF USED BRAKE FLUID PROPERLY. SEE THE GENERAL WARNINGS AT p. 2 (BRAKE FLUID).



DISC BRAKES

Carefully read page 2 (GENERAL SAFETY RULES) and page 49 (BRAKES).



⚠ WARNING

As mentioned above, the brakes are the most important safety system on your vehicle. For your safety, they must be in perfect repair, so they should be checked every time you ride your vehicle.

Oil or other fluid on a disc will contaminate the brake pads. Dirty pads must be discarded and replaced, a dirty or oily disc must be cleaned with a high quality degreaser.

Arrange to flush the systems and change all of the brake fluid once every two years.

NOTE This vehicle is provided with front and rear disc brakes with separate hydraulic systems.

NOTE  For the version with rear drum brake , the following information refers to the front disc brake only.

When the pads wear out the brake fluid level in the reservoir decreases to automatically compensate for their wear.

The front brake fluid reservoir is located on the right end of the handlebar near the front brake lever (under the upper handlebar cover).

The rear brake fluid reservoir is located on the left end of the handlebar near the rear brake lever (under the upper handlebar cover).

Check the levels of the brake fluid in the reservoirs, see p. 50 (FRONT AND REAR BRAKE). Also, check the wear of the pads, see p. 61 (CHECKING WEAR OF THE BRAKE PADS), every 300 mi (500 km).

⚠ WARNING

Never use your vehicle if any portion of either brake system is leaking.

FRONT AND REAR BRAKE

CHECKING THE SYSTEM

NOTE Carry out these checks only on a firm, flat surface such as a concrete garage floor.

- ◆ Place the vehicle on the center stand.

MIN = minimum level.

- ◆ Rotate the handlebar, so that the fluid contained in the brake reservoir (1) is parallel to the "MIN" mark stamped on the glass gauge (2).
- ◆ Ensure that the fluid contained in the reservoir exceeds the "MIN" mark stamped on the glass gauge (2). If not, top off.

⚠ WARNING

Use only DOT 5 or 4 fluid taken from a clean, sealed container. Never reuse used brake fluid.

⚠ CAUTION

When the disc pads wear out, the level of the fluid decreases progressively to compensate for their wear.

- ◆ Check the brake pad wear, p. 61 (CHECKING WEAR OF THE BRAKE PADS) and the disc wear.

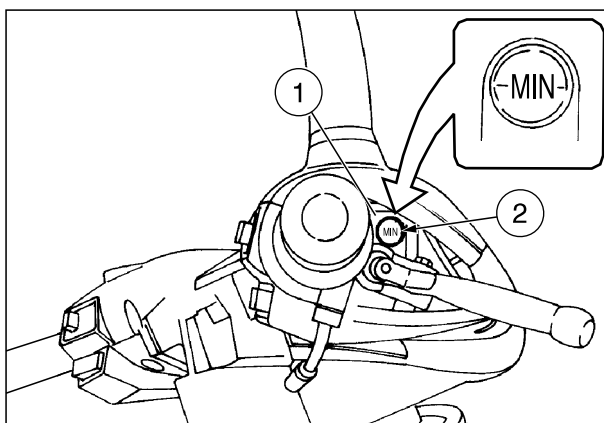

⚠ CAUTION

After servicing the brakes, always check them for function. If the stroke of the lever is excessive, or if you detect that the effectiveness of the brakes is reduced in any way.

It may be necessary to bleed the system see p. 62 (BLEEDING THE BRAKING SYSTEM), or there may be some other problem with the brake system.

Never ride your vehicle in traffic immediately after servicing the brakes.

Always apply the brake lever several times before riding your vehicle. Then, try your vehicle in a parking lot or other safe area with little traffic to ensure that the brakes are working properly. Failure to observe this warning can lead to a serious accident with subsequent serious injury or death.

CHECKING

To check the brake fluid level, proceed as follows:

NOTE Position the vehicle on firm and flat ground.

- ◆ Place the vehicle on the center stand.
- ◆ Rotate the handlebar, so that the fluid contained in the brake reservoir is parallel to the "MIN" mark stamped on the glass gauge (2).
- ◆ Make sure that the brake fluid contained in the reservoir exceeds the "MIN" mark stamped on the glass gauge (2).

If the fluid does not reach the "MIN" mark:

- ◆ Check the brake pad wear, see p. 61 (CHECKING WEAR OF THE BRAKE PADS).

If the pads do not need changing, proceed as follows:

- ◆ Check the brake system to determine the cause of the problem, checking:
 - the condition of the brake lines. Especially inspect for cracks or cuts;
 - the torque on the fittings;
 - the line fittings for leaks;
 - the brake caliper and the reservoir for leaks;
 - the bleed screw for leaks. If any seepage is observed, tighten to the appropriate tightening torque;
 - the reservoir caps for leaks and condition of the gasket.
- ◆ After you have repaired the brake, check and bleed the system.
- ◆ Top up the reservoir with appropriate brake fluid, see p. 52 (TOPPING UP).

TOPPING UP

- ◆ Remove the upper handlebar cover, see p. 24 (PARTIAL REMOVAL OF THE UPPER HANDLEBAR COVER).

⚠ CAUTION

The brake fluid may flow out of the reservoir. Do not operate the brake lever if the screws (3) are loose or, most important, if the brake fluid tank cover has been removed.

- ◆ Unscrew the two screws (3).
- ◆ Remove the cover (4).

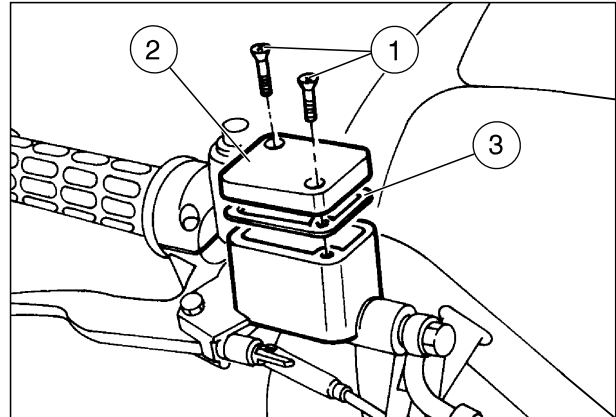
**⚠ WARNING**

Avoid any prolonged exposure of the brake fluid to the air.

The brake fluid is hygroscopic and when in contact with the air it absorbs moisture, which reduces the braking efficiency.

Leave the brake fluid tank open ONLY for the time necessary for topping up.

NOTE In order not to spill the brake fluid while topping up, keep the fluid in the reservoir parallel to the reservoir rim.

- ◆ Remove the gasket (5).

NOTE In order to reach the "MAX" level, top up until covering the glass (2) completely, with the brake fluid reservoir rim parallel to the ground.

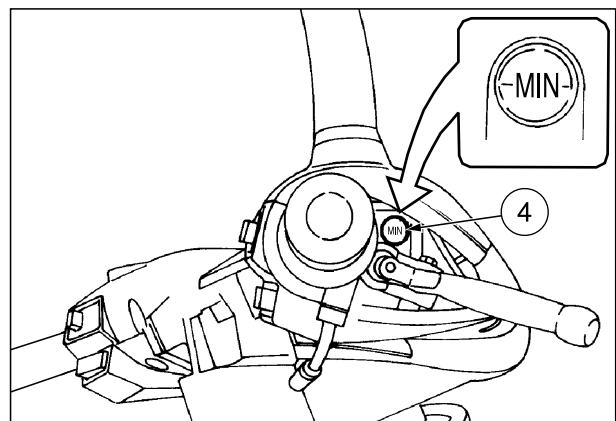
**⚠ CAUTION**

When topping up, never exceed the "MAX" level.

It is advisable to top up until reaching the "MAX" level only with new pads.

When the disc pads wear out, the level of the fluid decreases progressively to compensate for their wear.

Do not overfill the brake reservoir, especially if your scooter has worn pads, since when pads are replaced, this will cause brake fluid to overflow.

- ◆ Fill the tank with brake fluid, see p. 11 (LUBRICANT CHART), until it covers the glass completely.
- ◆ Replace the gasket (5) in its seat correctly.
- ◆ Replace the cover (4).
- ◆ Install and tighten the two screws (3).
- ◆ Replace the handlebar cover.
- ◆ Replace the rear-view mirrors.

REAR DRUM BRAKE (O)

Carefully read page 2 (GENERAL SAFETY RULES).

⚠ WARNING

The brakes are the parts that most ensure your safety and for this reason they must always be perfectly working.

ADJUSTING THE BRAKE

- ◆ Measure the distance covered by the lever before the brake starts its braking action. The idle stroke at the end of the brake lever must be about 0.39 in (10 mm).

To adjust the clearance:

- ◆ Rotate the adjuster (1). Rotating the adjuster nut clockwise decreases the clearance.
- ◆ Apply the brake repeatedly and make sure that the wheel turns freely after the lever has been released.
- ◆ Ride the vehicle, ensure that the rear brake is working properly.

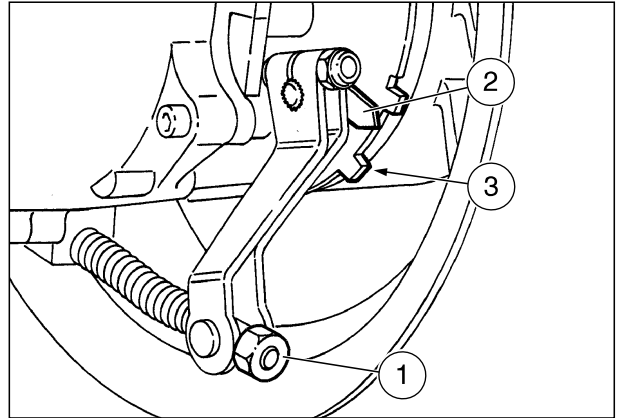

⚠ WARNING

If the adjuster (1) can be screwed completely on the rear brake cable, or the indicator pointer (2) points beyond the reference tooth (3), the brake shoes are worn out. In this case, see p. 63 (CHECKING THE SHOE WEAR (O)).

NOTE Heat that is generated during normal use of the brakes will change the clearance between the brake shoe and the drum. Because of this, you should check the clearance with the brakes at normal operating temperature.

- ◆ Test the brakes after any adjustment to ensure that they function properly.

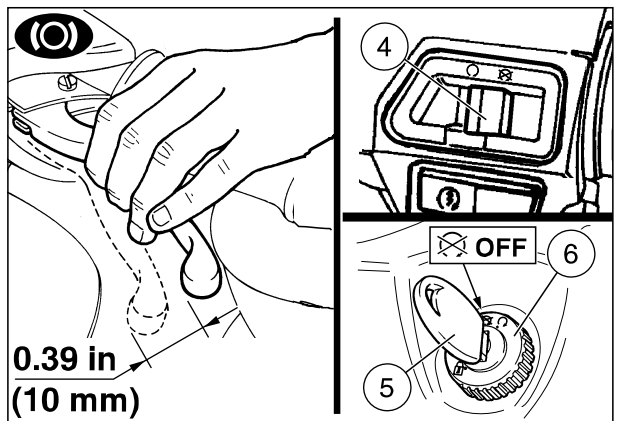

⚠ WARNING

After you have checked the brakes for function, it is necessary to ensure that there is adequate clearance between the brake shoes and the rear wheels.

Carry out this check with the engine at rest.

- ◆ Stop the vehicle.
- ◆ Move the engine stop switch (4) to position "OFF".
- ◆ Rotate the key (5) and move the ignition switch (6) to position "OFF".
- ◆ Place the vehicle on the center stand.

⚠ WARNING

When the engine is hot, be careful not to burn yourself while carrying out the following operations.

- ◆ Working from the left rear side of the vehicle, manually rotate the wheel and ensure that it turns freely.

If necessary:

- ◆ Loosen the adjuster (1), making sure that the wheel turns freely.

⚠ CAUTION

After servicing the brakes, always check them for function. If the stroke of the lever is excessive, or if you detect that the effectiveness of the brakes is reduced in any way, check the brake shoes, see p. 63 (CHECKING THE SHOE WEAR (O)).

Never ride your vehicle in traffic immediately after servicing the brakes. Always apply the brake lever several times before riding your vehicle. Then, try your vehicle in a parking lot or other safe area with little traffic to ensure that the brakes are working properly. Failure to observe this warning can lead to a serious accident with subsequent serious injury or death.

FRONT WHEEL**DISASSEMBLY**

Carefully read page 2 (GENERAL SAFETY RULES).

⚠ WARNING

While disassembling and reassembling the wheel, pay extra care not to damage the brake lines, discs or pads.

Before carrying out the following operations, let the engine and the exhaust silencer cool down until they reach room temperature, in order to avoid burns.

- ◆ Place the vehicle on the center stand.

NOTE Prepare a 200 mm high support (1), the base of which must measure 200 x 200 mm.

- ◆ Place the support (1) under the vehicle and a spongy cloth between them, so that the front wheel can move freely and the vehicle cannot fall down.
- ◆ Place a support (2) under the tire, in such a way as to keep the wheel in its position after loosening it.

⚠ WARNING

Make sure that the vehicle is stable. It may cause damage to bystanders and other property, as well as being damaged itself.

- ◆ Have a helper steady the handlebar in the straight ahead position.

Brake caliper screw (3) tightening torque: 19.53 ftlb (27 Nm).

- ◆ Remove the two screws (3) that fasten the front brake caliper (4).
- ◆ Remove the brake caliper (4) from the disc, leaving it attached to its line (5).

⚠ CAUTION

Never touch the front brake lever after removing the brake caliper from the disc. If you do, the caliper pistons may be pushed out of their seats, and brake fluid will be spilled.

- ◆ Hold the axle (6) from rotating with an appropriate Allen wrench.

Wheel nut (7) tightening torque: 36.17 ftlb (50 Nm).

- ◆ Remove the nut (7) and washer (8).

Screw (9) tightening torque: 8.68 ftlb (12 Nm).

- ◆ Loosen the two axle clamp screws (9), using the appropriate Allen wrench.
- ◆ Push the axle (6) partly out of the front fork by tapping the threaded end with a rubber hammer or wooden drift.

NOTE Observe the arrangement of the speedometer drive (11) and of the spacer ring (10), in order to be able to reassemble them correctly.

- ◆ Support the front wheel and remove the axle manually.
- ◆ Remove the spacer ring (10).
- ◆ Remove the wheel by pulling it forward.
- ◆ Disconnect the speedometer drive (11).

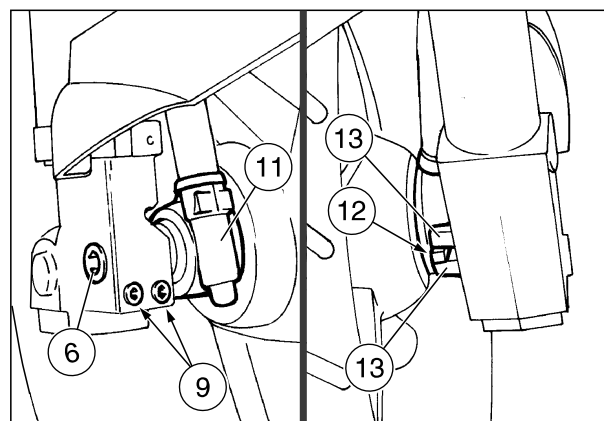
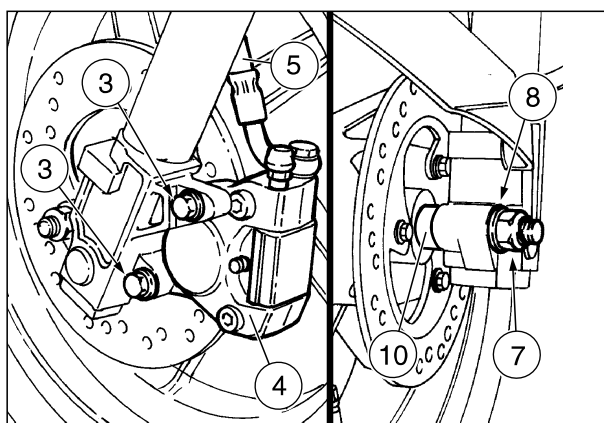
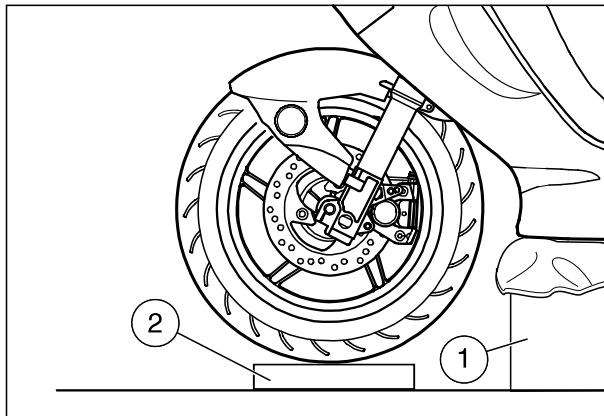

CHECKING

- ◆ Before reassembly, check the condition of the following parts, and if in any way damaged, replace them:
 - spacer (10);
 - bearings (14);
 - speedometer drive (11);
 - spacer (15);
 - brake disc (16), [(minimum thickness 0.118 in (3 mm))];
 - axle (6).
- ◆ Further, check the brake pad wear, see p. 61 (CHECKING WEAR OF THE BRAKE PADS).

REASSEMBLY

Carefully read page 2 (GENERAL SAFETY RULES).

⚠ WARNING

A dirty disc soils the pads, with consequent reduction of the braking efficiency. Dirty pads must be replaced, while dirty discs must be cleaned with a high-quality degreaser.

Riding with damaged rims is dangerous for the rider, the vehicle and other people.

Check the conditions of the wheel rim and have it changed if it is damaged.

While disassembling and reassembling the wheel, pay extra care not to damage the brake lines, discs or pads.

Before carrying out the following operations, let the engine and the exhaust silencer cool down until they reach room temperature, in order to avoid burns.

- ◆ Apply a thin film of lubricating grease, see p. 11 (LUBRICANT CHART) to the:
 - inside of the speedometer drive(11);
 - outer seats of the wheel hub;
 - front axle (6).
- ◆ Position the wheel on the support (2) between the fork legs.
- ◆ Position the boss of the speedometer drive (11) in the appropriate seat on the wheel hub.
- ◆ Position the spacer ring (10) in its seat on the wheel.
- ◆ Move the wheel around until to insert the tooth (12) of the speedometer drive (11) between the two antirotation pins (13) positioned on the fork.

⚠ WARNING

Danger of injury.

Keep your fingers clear. Do not attempt to line up the wheel and the axle clamps with your fingers.

- ◆ Move the wheel around until the axle hole and the axle clamps are aligned.
- ◆ Push in the axle (6) completely.
- ◆ Install the washer (8) and nut (7). Tighten finger tight.
- ◆ Hold the axle (6) from rotating using the Allen wrench.
- ◆ Tighten the nut (7) to its appropriate tightening torque.

Wheel nut (7) tightening torque:
36.17 ftlb (50 Nm).

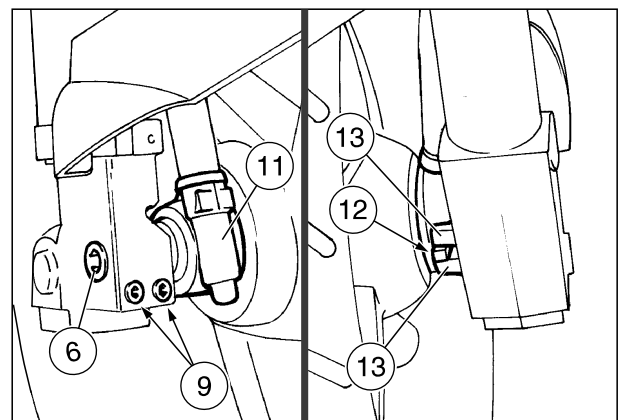
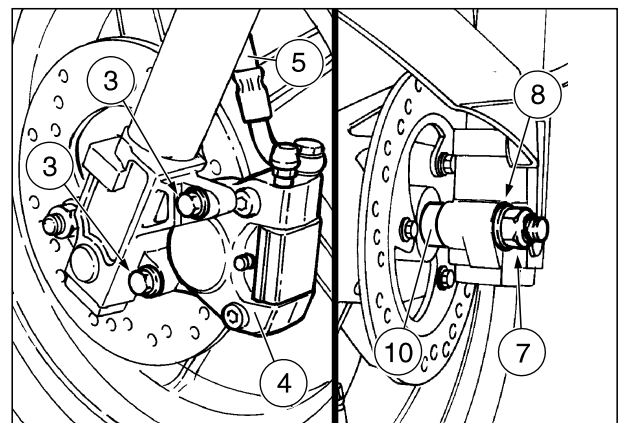
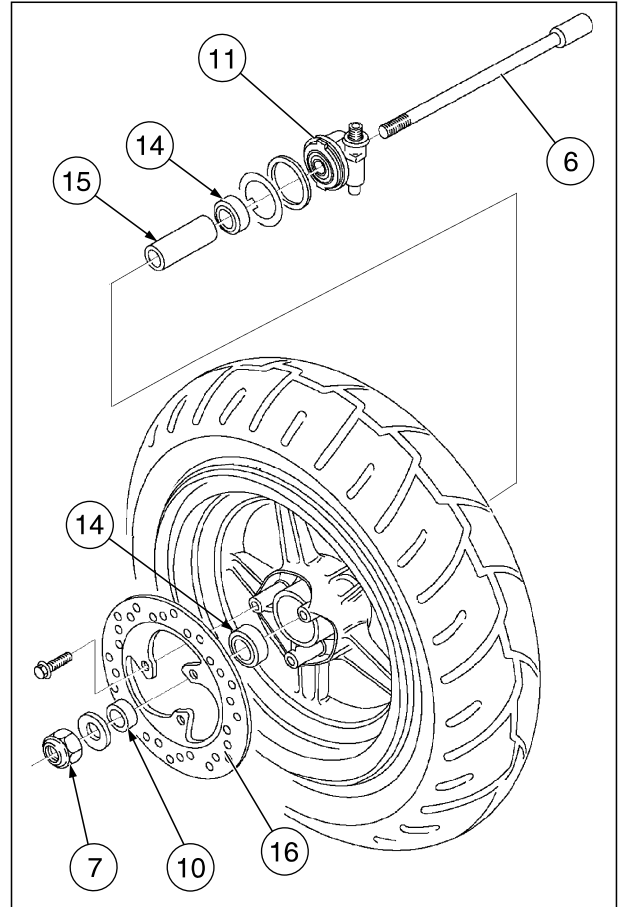

⚠ CAUTION

While reassembling the wheel, be careful not to damage the brake line, the disc and the pads.

- ◆ Insert the brake caliper (4) on the disc and position it so that its fastening holes and the holes on the support are aligned.

NOTE When reassembling the brake caliper, replace the caliper screws (3) with two new screws of the same type.

- ◆ Tighten the two screws (3) to the appropriate torque.
- Brake caliper screw (3) tightening torque: 19.53 ftlb (27 Nm).**
- ◆ Remove the support (2) from under the tire.
- ◆ Remove the support (1) from under the vehicle.
- ◆ Retract the center stand.
- ◆ Apply the front brake lever, and then push down on the handlebars, compressing the fork springs several times. This will align the fork tubes.
- ◆ Place the vehicle on the center stand.
- ◆ Tighten the two axle clamp screws (9).

Screw (9) tightening torque:
8.68 ftlb (12 Nm).

⚠ WARNING

After servicing the brakes, always check them for function. If the stroke of the lever is excessive, or if you detect that the effectiveness of the brakes is reduced in any way, check the brake system, see p. 50 (DISC BRAKES). It may be necessary to bleed the system, or there may be some other problem with the brake system.

Never ride your vehicle in traffic immediately after servicing the brakes. Always apply the brake lever several times before riding your vehicle. Then, try your vehicle in a parking lot or other safe area with little traffic to ensure that the brakes are working properly. Failure to observe this warning can lead to a serious accident with subsequent serious injury or death.

Check the tightening torques, centering and balancing of the wheel, see p. 66 (INSPECTING THE WHEELS). These are critical safety operations, and failure to observe this warning could lead to an upset with subsequent serious injury or death.

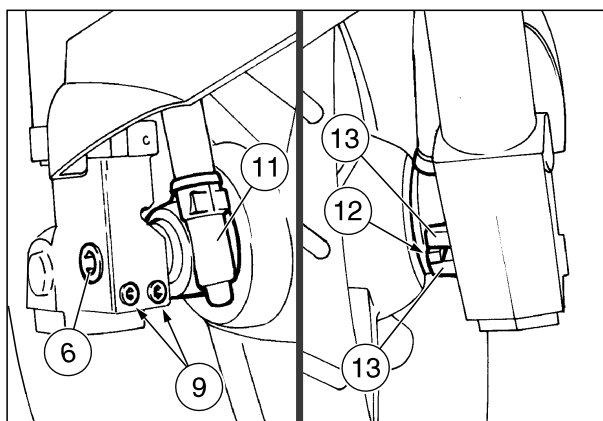
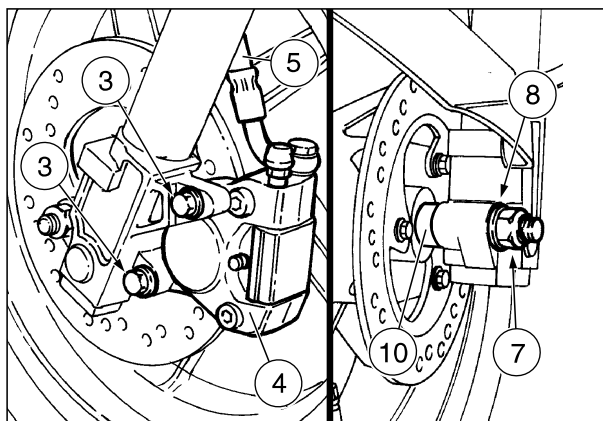
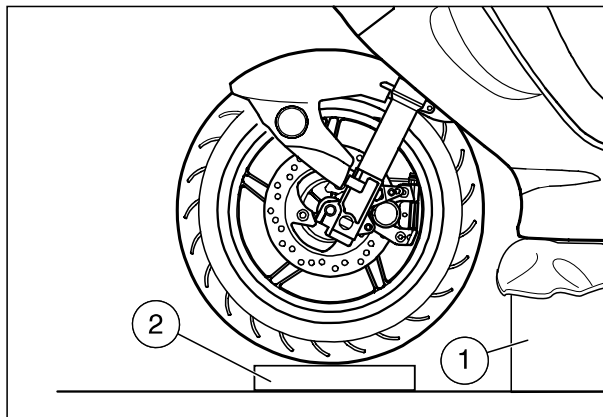

REAR WHEEL

DISASSEMBLY

Carefully read page 2 (GENERAL SAFETY RULES).

⚠ WARNING

A dirty disc soils the pads, with consequent reduction of the braking efficiency. Dirty pads must be replaced, while dirty discs must be cleaned with a high-quality degreaser.

Riding with damaged rims is dangerous for the rider, the vehicle and other people. Check the conditions of the wheel rim and have it changed if it is damaged.

While disassembling and reassembling the wheel, pay extra care not to damage the brake lines, discs or pads.

- ◆ Remove the exhaust silencer, see p. 73 (EXHAUST SILENCER - DISASSEMBLY).

NOTE To unscrew the wheel nut (1), it is necessary to lock the rotation of the wheel.

- ◆ Pull the rear brake lever (2) completely, then put a small piece of cardboard (3) on the grip and keep the rear brake lever pulled by holding it against the grip by means of a plastic band (4).
- ◆ Remove the cover (5).
- ◆ Unscrew and remove the wheel nut (1) and the washer.

NOTE Upon reassembly, use a new wheel nut. Do not reassemble your vehicle using the old wheel nut. This wheel nut is of a special type.

Wheel nut (1) tightening torque:
79.56 ftlb (110 Nm).

- ◆ Remove the plastic band (4) and the cardboard (3).
- ◆ Release the rear brake lever (2).
- ◆  Withdraw the wheel.
- ◆ Remove the rear brake caliper (6), see pag. 60 (REMOVING THE REAR BRAKE CALIPER).
- ◆ Withdraw the wheel.

⚠ WARNING

After servicing the brakes, always check them for function. If the stroke of the lever is excessive, or if you detect that the effectiveness of the brakes is reduced in any way, check the brake system, see p. 50 (DISC BRAKES) it may be necessary to bleed the system, or there may be some other problem with the brake system.

Never ride your vehicle in traffic immediately after servicing the brakes.

Always apply the brake pedal or lever several times before riding your vehicle. Then, try your vehicle in a parking lot or other safe area with little traffic to ensure that the brakes are working properly. Failure to observe this warning can lead to a serious accident with subsequent serious injury or death.

Check the tightening torques, centering and balancing of the wheel, see p. 66 (INSPECTING THE WHEELS). These are critical safety operations, and failure to observe this warning could lead to an upset with subsequent serious injury or death.

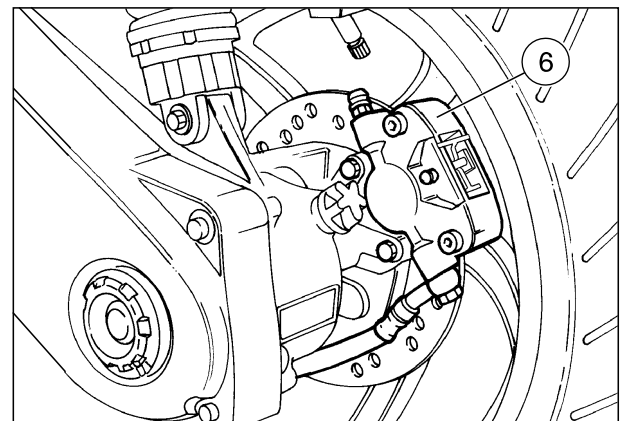
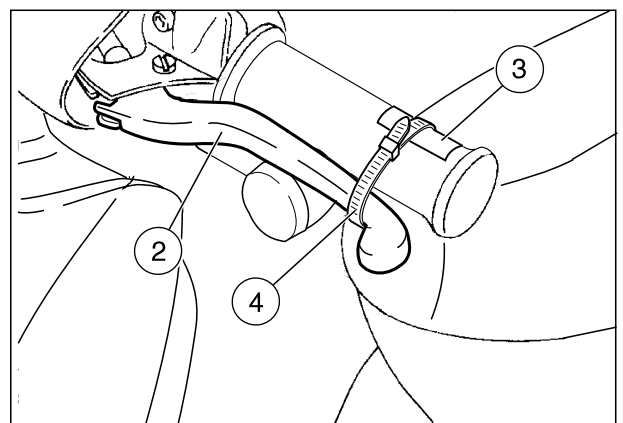
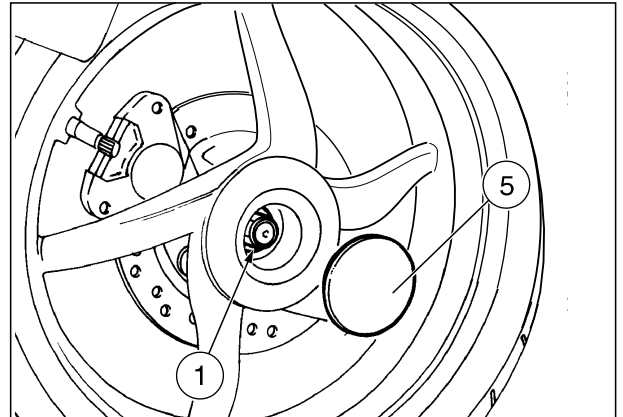

GREASING THE REAR BRAKE CAM PIN

Carefully read page 2 (GENERAL SAFETY RULES).

NOTE Grease the rear brake cam pin every 2,500 mi (4,000 km). If the vehicle is used on dusty roads, this operation must be carried out more frequently.

- ◆ Disassemble the rear wheel, see p. 57 (REAR WHEEL - DISASSEMBLY).
- ◆ Unscrew and remove the adjuster (1).

CAUTION

Be careful not to contaminate the shoes, and the friction material in particular, with grease. This will seriously compromise the braking efficiency of the vehicle.

CAUTION

It will be difficult to remove the shoes as shown in the figure beside because the springs are very strong. Be careful not to pinch or smash your hands or fingers.

Avoid stretching or twisting the springs (2), they can be damaged if you do this.

- ◆ Grasp the inner edge of the shoes(3) near the center, and pull them towards you as shown in the arrows. This operation will be made easier if the brake cam is so positioned as to spread the shoes as far as possible. Be careful not to chip the edge of the shoes, especially on the anchor pin, as you gently pull them from the backing plate.
- ◆ Remove the rear brake cam lever by holding the clamp bolt (4) with an Allen wrench, and unscrewing the nut (5).
- ◆ Remove the rear brake lever (6).
- ◆ Remove the cam pin (7).

CAUTION

Sparingly grease only the part of the cam which passes through the backing plate. Avoid getting excessive grease on the cam or areas around the pin boss, see p. 11 (LUBRICANT CHART).

Upon reassembly:

CAUTION

Do not hit the cam with a hammer, or try to force it into position. It is fit with two O-rings which must be in good condition before reassembly. If they are not, replace the O-rings.

- ◆ Push the cam pin (7) into position, rotating and pushing gently. Insure that it is adequately lubricated before attempting to assemble.
- ◆ Replace the two friction elements (3), coupling the plane ends (8) with the cam pin (7) and the shaped ends (9) with the fulcrum pin (10).

CAUTION

Make sure that the two springs (2) are correctly attached.

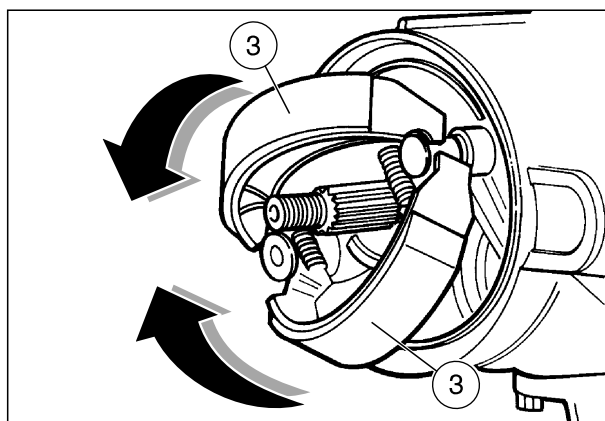
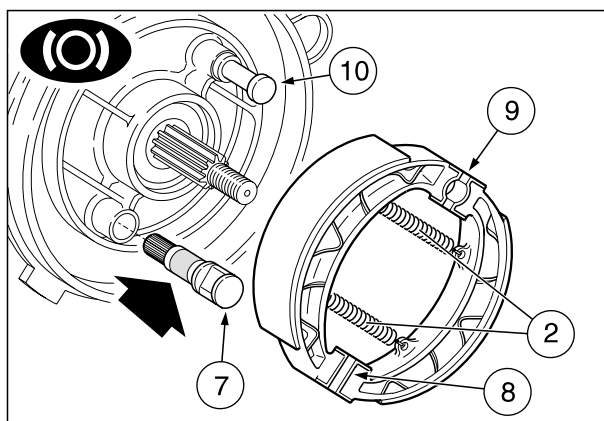
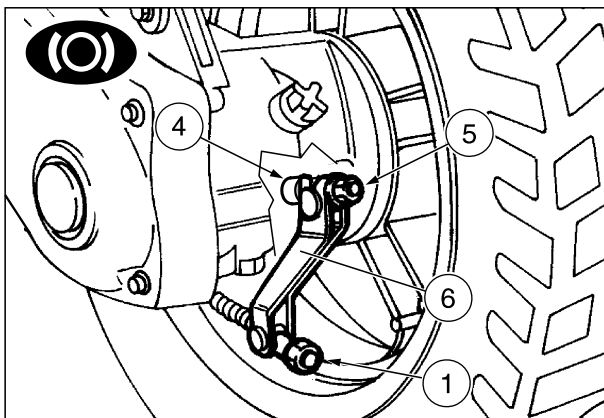

BRAKE CALIPERS

REMOVING THE FRONT BRAKE CALIPER

Carefully read page 2 (GENERAL SAFETY RULES), p. 49 (BRAKES), p. 50 (DISC BRAKES).

⚠ WARNING

A dirty disc soils the pads, with consequent reduction of the braking efficiency. Dirty pads must be replaced, while dirty discs must be cleaned with a high-quality degreaser.

Riding with damaged rims is dangerous for the rider, the vehicle and other people.

Check the condition of the rim and replace it if it is damaged.

⚠ CAUTION

Upon disassembly, be careful not to damage the brake lines, disc and pads.

- ◆ Place the vehicle on the center stand.
- ◆ Unscrew and remove the two screws (1).

Brake caliper screw tightening torque (1):
19.53 ftlb (27 Nm).

⚠ WARNING

Upon reassembly of the brake caliper, replace the caliper fastening screws (1) with two new screws of the same type.

⚠ CAUTION

Never apply the front brake lever after removing the brake caliper. To do so will cause the caliper pistons to fall out of their seats in the caliper. This will cause brake fluid to spill from the caliper.

- ◆ Remove the brake caliper (2), by carefully withdrawing it from the brake disc.

⚠ CAUTION

After reassembly, pull the front brake lever repeatedly and check the correct functioning of the braking system.

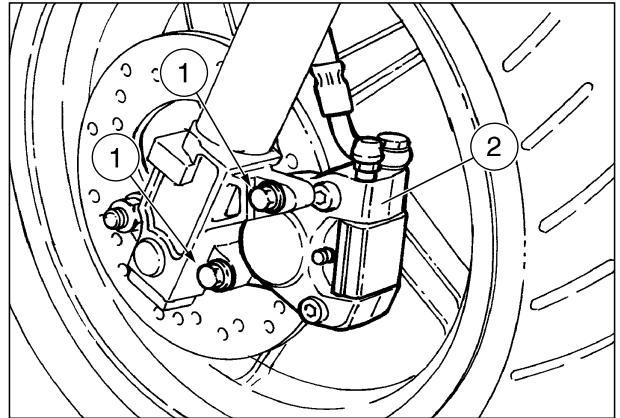

REMOVING THE REAR BRAKE CALIPER

Carefully read page 2 (GENERAL SAFETY RULES), p. 49 (BRAKES), p. 50 (DISC BRAKES).

WARNING

A dirty disc soils the pads, with consequent reduction of the braking efficiency. Dirty pads must be replaced, while dirty discs must be cleaned with a high-quality degreaser.

Riding with damaged rims is dangerous for the rider, the vehicle and other people. Check the condition of the rim and replace it if it is damaged.

CAUTION

Upon disassembly, be careful not to damage the brake lines, disc and pads.

WARNING

Before carrying out the following operations, let the engine and the exhaust silencer cool down until they reach room temperature, in order to avoid burns.

- ◆ Place the vehicle on the center stand.
- ◆ Unscrew and remove the two screws (1).

Brake caliper screw tightening torque (1):
19.53 ftlb (27 Nm).

WARNING

Upon reassembly of the brake caliper, replace the caliper fastening screws (1) with two new screws of the same type.

CAUTION

Never apply the front brake lever after removing the brake caliper. To do so will cause the caliper pistons to fall out of their seats in the caliper. This will cause brake fluid to spill from the caliper.

- ◆ Remove the brake caliper (2), by carefully withdrawing it from the brake disc.

WARNING

After reassembly, pull the rear brake lever repeatedly and check the correct functioning of the braking system.

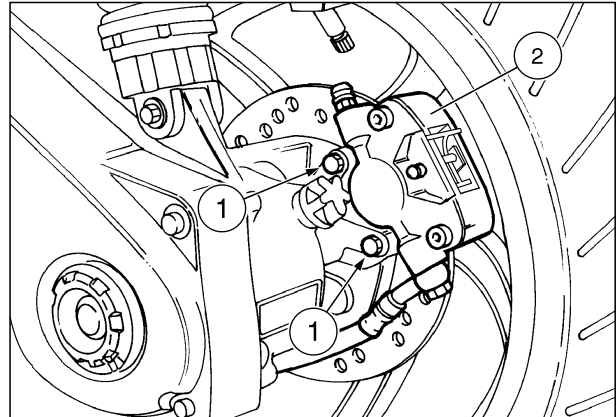

BRAKE PADS

Carefully read page 2 (GENERAL SAFETY RULES), p. 49 (BRAKES), p. 50 (DISC BRAKES).

Check the brake pad wear after the first 300 mi (500 km) and successively every 1,250 (2,000 km).

The amount of wear that the brake pads experience depends on how the vehicle is used, how aggressively it is driven, and the condition of the roads upon which it is operated. Wear will be faster than normal when the vehicle is driven aggressively, or on dusty or wet roads.

CHECKING WEAR OF THE BRAKE PADS

- ◆ Place the vehicle on the center stand.
- ◆ **Only for the front brake caliper:** remove the brake caliper cover (1).

NOTE To check the rear brake pad wear, remove the rear brake caliper (2), see pag. 60 (REMOVING THE REAR BRAKE CALIPER).

- ◆ Perform a visual check of the friction material thickness. Use a flash light.

If the friction material on one pad of a pair, front or rear, is worn to **0.06 in (1.5 mm)** or less, replace both pads.

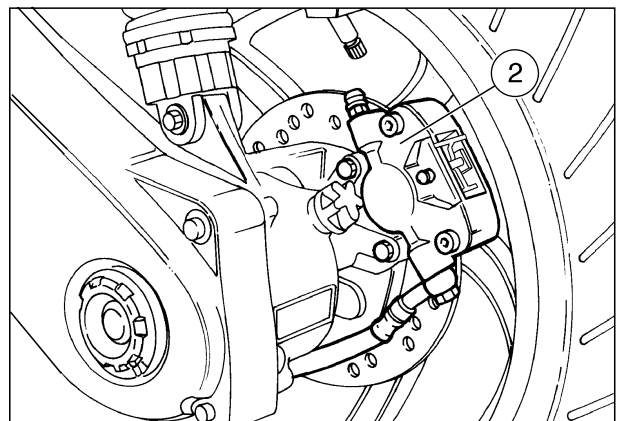
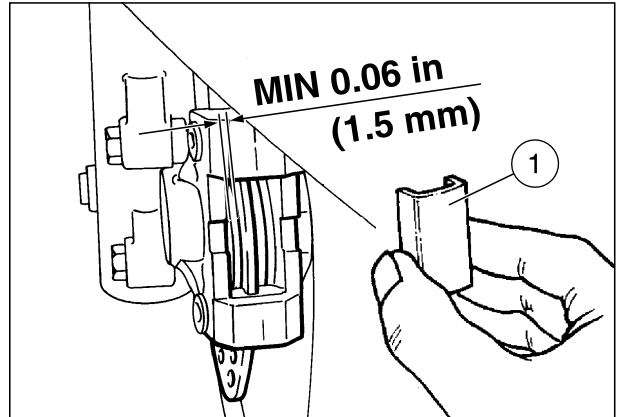

⚠ WARNING

Excessive wear of the friction material would cause the contact of the pad metal support with the disc, with consequent metallic noise and production of sparks from the caliper; braking efficiency and safety will be seriously compromised. This could lead to a crash, with subsequent serious injury or death.

CHANGING THE BRAKE PADS

- ◆ Place the vehicle on the center stand.

Only for the front brake caliper:

- ◆ Remove the brake caliper cover (1).
- ◆ Remove the snap ring (3).
- ◆ Withdraw the pin (4).
- ◆ Remove the spring (5).
- ◆ Extract the pads (6), by withdrawing them one by one.

Only for the rear brake caliper:

- ◆ Remove the antisqueal plates (7).

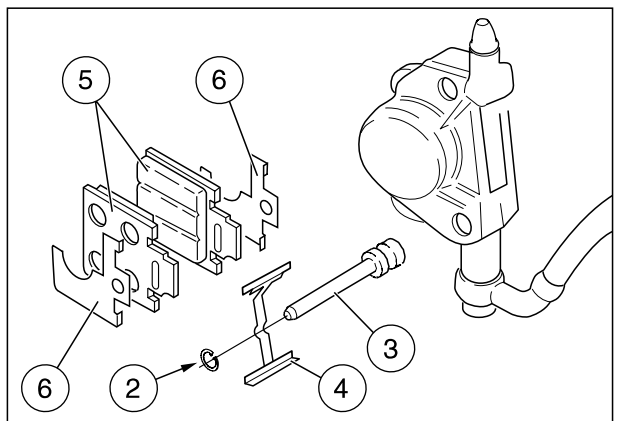

⚠ CAUTION

Never apply the brake levers after removing the brake caliper. To do so will cause the caliper pistons to fall out of their seats in the caliper. This will cause brake fluid to spill from the caliper.

Always change both pads and make sure that they are correctly positioned inside the caliper.

- ◆ Insert two new pads.

Only for the rear brake caliper:

- ◆ Replace the antisqueal plates (7).
- ◆ Insert the spring (3) correctly.
- ◆ Insert the pin (4).
- ◆ Install the snap ring (3).

Only for the front brake caliper:

- ◆ Replace the brake caliper cover (1).
- ◆ Check the brake fluid level, see p. 51 (DISC BRAKES - CHECKING).

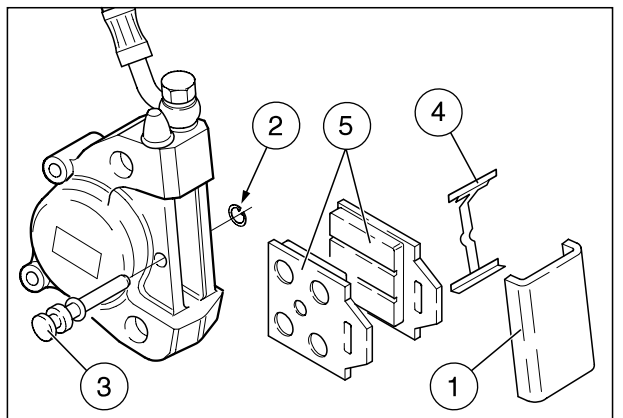

BLEEDING THE BRAKING SYSTEM

Carefully read page 2 (GENERAL SAFETY RULES), p. 49 (BRAKES).

NOTE For the version with rear drum brake , the following information refers to the front disc brake only.

When air is present in the hydraulic system it will absorb most of the force exerted by the brake master cylinder, and thus reduce the effectiveness of caliper action during braking. You can tell if there is air in the system by sponginess in the brake control, and reduced braking efficiency.

⚠ WARNING

Since these conditions would be extremely dangerous for the vehicle and for the rider, it is absolutely necessary to bleed the hydraulic circuit after the reassembly of the brakes and the restoration of the normal conditions of use.

- ◆ Remove the front handlebar cover, see p. 24 (REMOVING THE LOWER HANDLEBAR COVER), to reach the tank (1).
- ◆ Unscrew the two screws (2).
- ◆ Remove the cover (3).

⚠ WARNING

Avoid any prolonged exposure of the brake fluid to the air.

The brake fluid is hygroscopic and when in contact with the air it absorbs moisture, which reduces the braking efficiency.

Leave the brake fluid tank open **ONLY** for the time necessary for topping up.

NOTE It is advisable to keep the fluid in the tank parallel to the tank edge (in horizontal position), in order not to spill it while topping up.

- ◆ Remove the gasket (4).
- ◆ Make sure that the fluid covers the glass (5) completely and top up if necessary.
- ◆ Remove the protection cap (6) from the bleeder nipple (7).
- ◆ Connect a transparent tube (8) to the bleeder nipple (7).

⚠ CAUTION

Do not contaminate the pads or the disc with brake fluid.

- ◆ Put the free end of the transparent tube (8) into a clear container (9).
- ◆ Slowly pull the brake lever through its full travel two or three times, then keep it in a fully pulled position.

⚠ CAUTION

Loosen the bleeder nipple (7) and check the brake fluid level in the reservoir (1). Do not allow the reservoir to become completely empty. This will cause the introduction of more air into the brake system.

- ◆ Loosen the bleeder nipple and check to see if bubbles still appear in the transparent tube.

⚠ CAUTION

Before releasing the brake lever, close the bleeder nipple (7) in order to prevent air from entering the brake system that way.

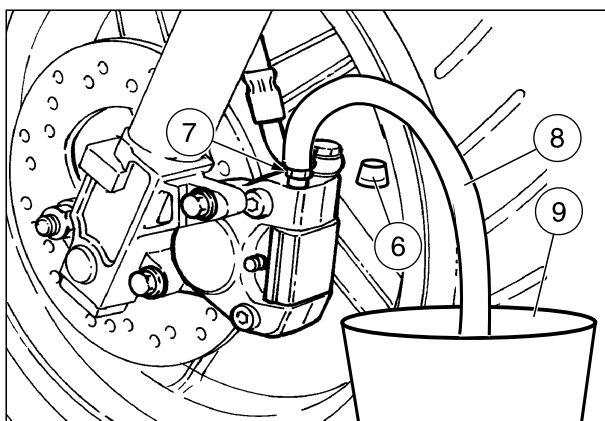
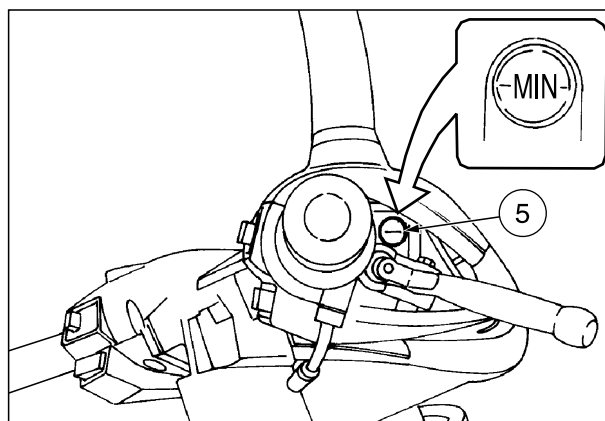
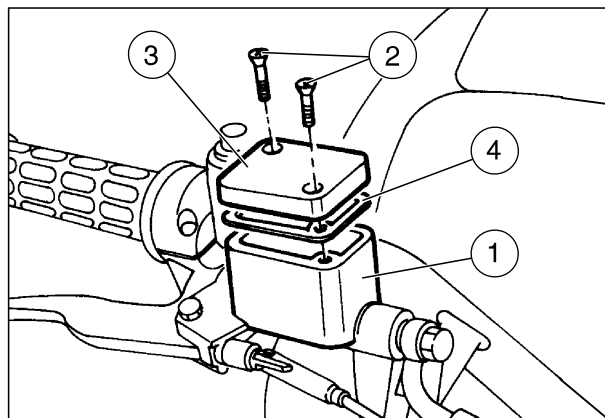

- ◆ When brake fluid flows out clear, without bubbles, this indicates that you have successfully bled the air from the brake system. Close the bleeder nipple snugly, and torque it to 2.90 ÷ 8.68 in (4 ÷ 12 Nm).
- ◆ Replace the bleeder nipple cap.

NOTE Repeat the last three operations until eliminating the air bubbles completely.

- ◆ Check the brake fluid level, see p. 51 (DISC BRAKES - CHECKING).

⚠ WARNING

After reassembly, pull the brake lever repeatedly and check the proper functioning of the braking system.

BRAKE SHOES (C)

Carefully read page 2 (GENERAL SAFETY RULES), p. 53 (REAR DRUM BRAKE (C)).

CHECKING THE SHOE WEAR (C)

Check the wear of the rear brake shoes after the first 312 mi (500 km) and successively every 2,500 mi (4,000 km).

To verify the wear of the rear brake shoes, proceed as follows:

- ◆ Pull the rear brake lever (1) completely and keep it pulled.
- ◆ Check the position of the rear brake shoe wear indicator (2).

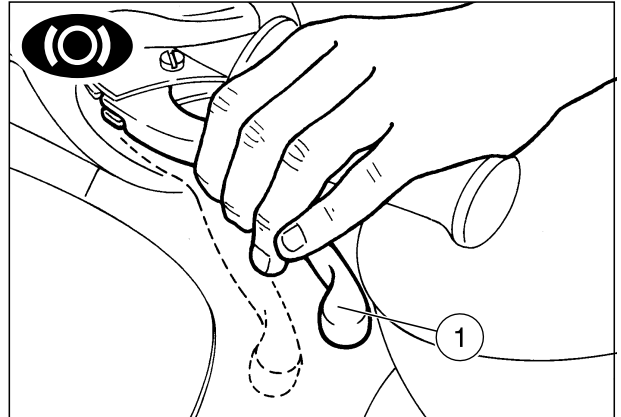

Position	Wear condition
Indicator between the two reference teeth (3) and (4).	Rear brake shoes within the wear limit.
Indicator on or beyond the lower reference tooth (4).	Rear brake shoes worn. To be replaced.

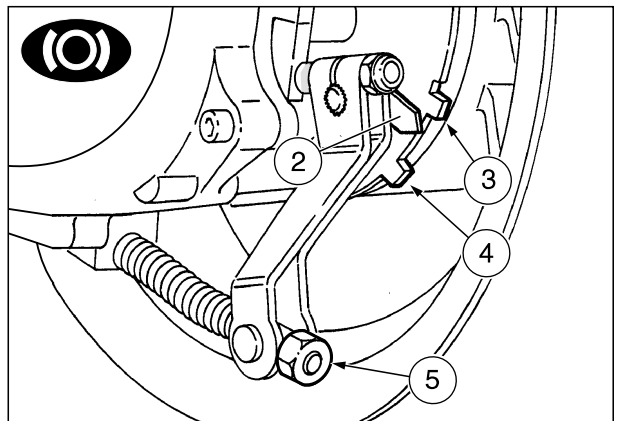

⚠ CAUTION

If the rear brake shoe wear indicator (2) is positioned on or beyond the lower reference tooth (4), must be checking the thickness of the friction material, see p. 63 (CHECKING THE THICKNESS OF THE FRICTION MATERIAL (C)).

CHECKING THE THICKNESS OF THE FRICTION MATERIAL (C)

To check the thickness of the friction material proceed as follows:

- ◆ Remove the rear wheel, p. 57 (REAR WHEEL).
- ◆ At this point it is possible to check the thickness of the friction material, which must never be less than 0.04 in (1 mm). If the minimum allowed limit has been reached, if you notice any roughness in the brake operation, or if any part is damaged, replace the shoes, see p. 64 (REPLACING THE SHOES (C)).

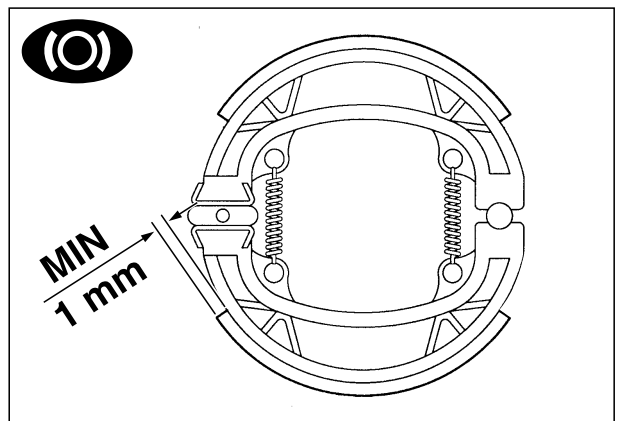

REPLACING THE SHOES

After checking:

- ◆ Unscrew and remove the adjuster (1).

CAUTION

Be careful not to contaminate the shoes, and the friction material in particular, with grease. This will seriously compromise braking efficiency.

CAUTION

It will be difficult to remove the shoes as shown in the figure beside because the springs (2) are very strong. Be careful not to pinch or smash your hands or fingers.

Avoid stretching or twisting the springs (2), they can be damaged if you do this.

To remove the shoes:

- ◆ Grasp the inner edge of the friction elements (3) near the center, and pull them towards you as shown in the arrows. This operation will be made easier if the brake cam is so positioned as to spread the shoes as far as possible. Be careful not to chip the edge of the shoes, especially on the anchor pin, as you gently pull them from the backing plate.
- ◆ Replace the shoes with new ones.

NOTE Replace the two friction elements (3), coupling the plane ends (4) with the cam pin (5) and the shaped ends (6) with the fulcrum pin (7).

CAUTION

Upon reassembly, make sure that the springs (2) are correctly hooked.

- ◆ Reassemble the wheel complete with shoes.
- ◆ Tighten the adjuster (1).
- ◆ Adjust the brake, see p. 53 (REAR DRUM BRAKE  - ADJUSTING THE BRAKE).

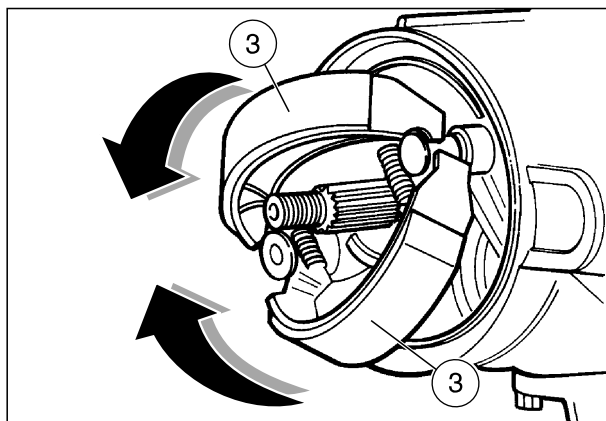
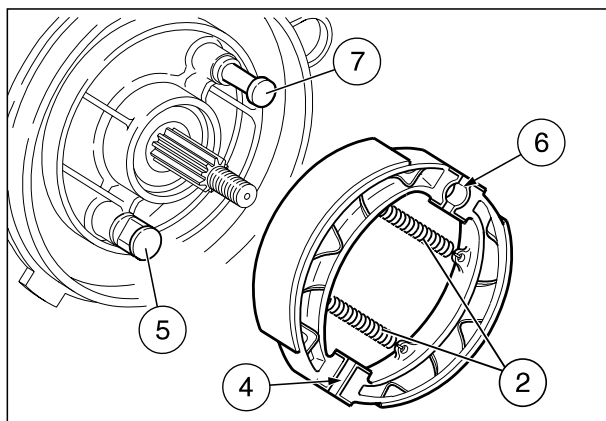
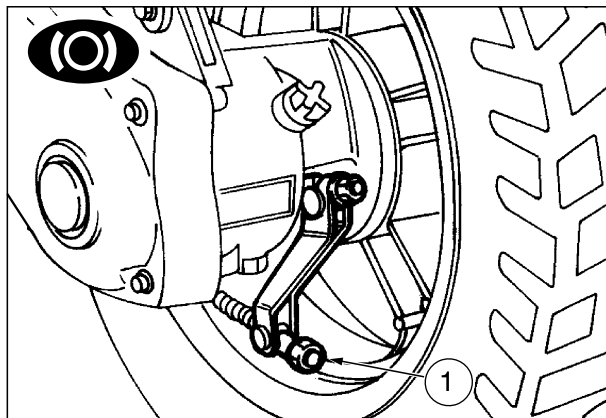

TRANSMISSION

⚠ CAUTION

The oil can cause serious damage to the skin if handled every day and for long periods.
Wash your hands carefully after using the oil.

In case any maintenance operation has to be carried out, it is advisable to use latex gloves.

Dispose of used transmission oil properly. Used oil should be returned to an oil recycling center.

⚠ CAUTION

Tighten the filling cap and the drain plug thoroughly and make sure that there are no oil leaks.
Periodically check that there are no leaks in correspondence with the oil pan cover seal.
Do not use the vehicle with insufficient lubrication or with contaminated or unsuitable lubricants, since this would accelerate the wear of the moving parts and may also cause irreparable failures.

CHECKING THE TRANSMISSION OIL LEVEL

Carefully read page 2 (GENERAL SAFETY RULES) and above (TRANSMISSION).

To check the transmission oil level, carry out the following operations every 1,875 mi (3,000 km) or every 6 months:

- ◆ Ride for a few miles until the engine reaches its normal running temperature, then turn the engine off.
- ◆ Place the vehicle on the center stand.
- ◆ Put a graduated container (1) with at least 120 cm³ capacity under the drain plug (2).
- ◆ Unscrew the filling cap (3) and the oil drain plug (2).
- ◆ Let all the oil flow out of the oil pan, measure the quantity and if it is less than 110 cm³, top up by adding the lacking quantity, see p. 11 (LUBRICANT CHART).
- ◆ Tighten the drain plug (2).
- ◆ Provide for filling up, using the oil collected into the graduated container (1).
- ◆ Tighten the filling cap (3).

CHANGING THE TRANSMISSION OIL

Carefully read page 2 (GENERAL SAFETY RULES) and page 65 (TRANSMISSION).

To ensure the efficiency and long life of the vehicle, it is necessary to change the oil after the first 500 km and thereafter every 7,500 mi (12,000 km) or every 2 years.

Proceed as follows:

- ◆ Drive for a few miles until the engine reaches the normal running temperature, then stop the engine.
- ◆ Place the vehicle on the center stand.
- ◆ Put a graduated container (1) with at least 120 cm³ capacity under the drain plug (2).
- ◆ Unscrew the filling cap (3) and the oil drain plug (2).
- ◆ Let all the oil flow out of the oil pan.
- ◆ Tighten the drain plug and add 110 cm³ of oil, see p. 11 (LUBRICANT CHART).
- ◆ Tighten the filling cap (3).

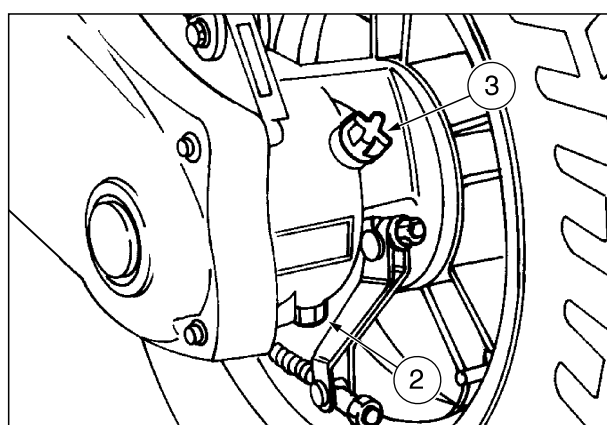
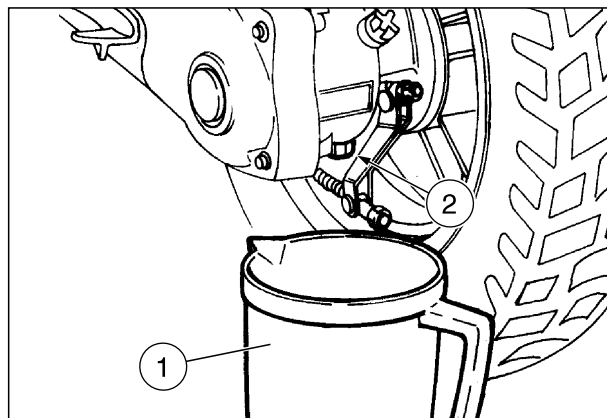

CHECKING THE ENGINE FULCRUM AXIS

Carefully read page 2 (GENERAL SAFETY RULES).

Periodically check the slack existing between the engine pin bushings.

To carry out this operation, proceed as follows:

- ◆ Place the vehicle on the center stand.

⚠ WARNING

Before carrying out the following operations, let the engine and the exhaust silencer cool down until they reach room temperature, in order to avoid burns.

- ◆ Shake the wheel transversally with respect to the riding direction.
- ◆ If any slack is detected, the vehicle must be repaired.

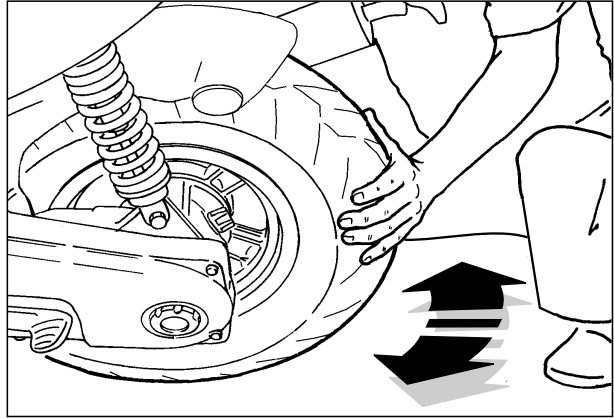

WHEELS / TIRES

Carefully read page 2 (GENERAL SAFETY RULES).

This vehicle is equipped with tubeless tires.

INSPECTING THE WHEELS

- ◆ Make sure that the wheel rims are neither cracked, nor deformed. Change them if necessary.
- ◆ Check the wheel eccentricity.
If it is deformed beyond the tolerance limits, check the rim and the bearings.
If necessary, change the wheel.

Eccentricity limit:

Vertical: 0.07874 in (2mm).

Lateral: 0.07874 in (2mm).

- ◆ Check the wheel balancing.
- ◆ Place the wheel on a balancing stand, and rotate it several times, observing the position in which the wheel stops.

If the wheel is statically balanced, it will not always stop in the same place. If it always stops in the same place, the wheel is out of balance, and must be balanced. Place balancing weights on the lightest side of the wheel until it no longer stops in any one position after being rotated several times.

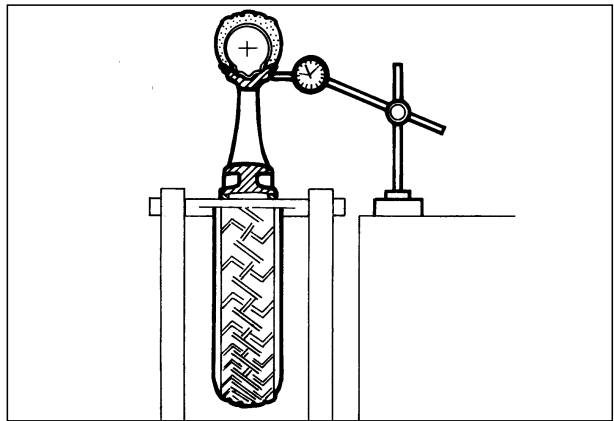

TIRES

Carefully read page 2 (GENERAL SAFETY RULES).

⚠ WARNING

Check the tire inflation at room temperature at least once a week, see p. 9 (TECHNICAL DATA).

Pressure measurement must always be carried out when the tires are cold, as when the tires are warmed up, pressure will increase, and if they are checked at this time erroneous readings will be seen.

If the tire is inflated to too high a pressure, an uncomfortably harsh ride will result, and riding comfort will be compromised. Also, road holding, especially during turns and in wet conditions, will likewise be compromised.

If the tire is underinflated (pressure is too low), the tire may slip on the rim with consequent loss of control. Again, road holding and handling characteristics will be degraded, and brake performance will be reduced.

When the tire is worn to a point where any tread is less than 0.12 in (3 mm) deep, the tire is worn out, and must be replaced. Also, if a tire suffers a puncture that is larger than 0.20 in (5 mm) in its longest dimension, the tire must not be repaired, but should be replaced.

After a tire is repaired, balance the wheels. Use only tires that are listed, see p. 9 (TECHNICAL DATA).

Insure that all tires are equipped with properly installed valve caps.

⚠ WARNING

Change, repair, maintenance and balancing operations are very important and should be carried out by qualified technicians with appropriate tools.

If the tires are new, they may still be covered with a slippery film: drive carefully for the first miles. Do not oil the tires with unsuitable fluids.

Never attempt to treat a tire with any kind of rubber dressing. Particularly avoid contact to the tire with any petroleum fluid as this will cause rapid deterioration of the rubber.

In this case, replace them.

- ◆ Check the tire frequently and make sure that there are neither breakages, nor cuts.
- ◆ Swelling and waving are sign of internal damages requiring the immediate change of the tire.

⚠ WARNING

Some of the original equipment tires for this vehicle, are provided with wear indicators.

There are several kinds of wear indicators.

Contact your dealer to get the necessary information on the wear check procedures.

Visually check the tire wear and if they are worn, have them replaced.

If a tire should go flat while you are riding the vehicle, do not attempt to continue riding. Avoid abrupt braking and steering inputs, and avoid shutting the throttle quickly. Slowly decrease the throttle setting, moving to the side of the road, using the engine compression to slow you to a stop. Non-compliance with these instructions may cause accidents with consequent risk of injuries or even death.



Do not install tires with air tube on rims for tubeless tires and viceversa.

Minimum tread depth is measured as shown above. The minimum tread depth (1) for both the front and the rear tires is 0.12 in (3 mm).

TIRE PRESSURE

Condition	Front	Rear
only rider	24.65 psi [170 kPa (1.7 bar)]	27.55 psi [190 kPa (1.9 bar)]
rider and one passenger (in the countries where this is allowed)	24.65 psi [170 kPa (1.7 bar)]	30.65 psi [210 kPa (2.1 bar)]

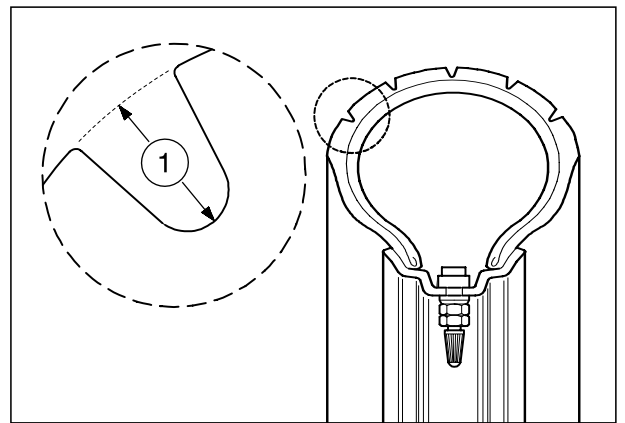

FORK HEAD

Carefully read page 2 (GENERAL SAFETY RULES).

CHECKING THE STEERING

Carefully read p.2 (GENERAL SAFETY RULES).

Occasionally check the steering slack.

To check the steering it is necessary to:

- ◆ Place the vehicle on the center stand.

NOTE Prepare a 7.784 in (200 mm) high support, the base of which must measure 7.874 x 7.874 in (200 x 200 mm).

- ◆ Place the support under the vehicle and a spongy cloth between them, so that the front wheel can move freely and the vehicle cannot fall down.

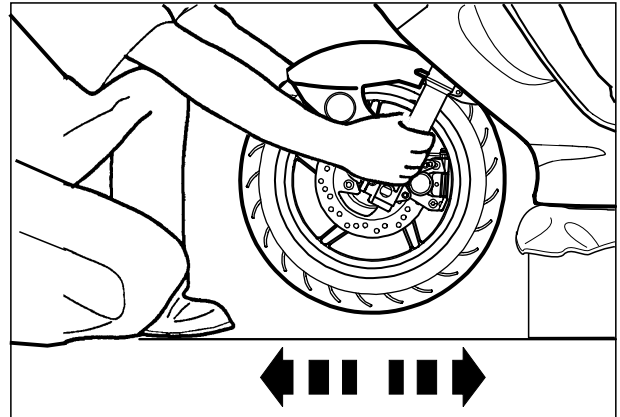

⚠ WARNING

Make sure that the vehicle is stable.

- ◆ Shake the fork in the direction of travel.

NOTE Do not shake the fork excessively, otherwise you may take in consideration the movement of the stand, thus observing an incorrect slack. Repeat the previous operation more than once.

- ◆ Fore and aft slack should be no considerable. If slack at the axle is considerable, the bearing play must be adjusted, see below (ADJUSTING THE BEARING PLAY).

ADJUSTING THE BEARING PLAY

- ◆ Remove the front inner shield, see p. 22 (REMOVING THE FRONT INNER SHIELD).
- ◆ Unscrew and remove the nut (1).
- ◆ Withdraw and remove the screw (2).
- ◆ Loosen the nut (3).

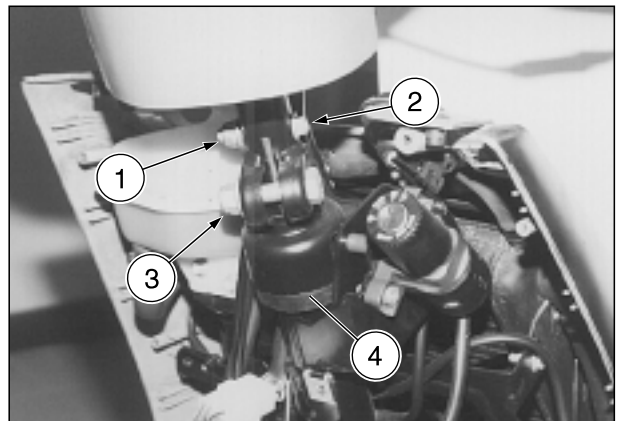

Nut tightening torque (3): 36.17 ftlb (50 Nm) .

- ◆ Raise the handlebars of a few centimetres.
- ◆ Remove the rubber gasket (4).
- ◆ Loosen the lock nut (5).

⚠ CAUTION

Do not over tighten the adjusting nut (6). Over tightening the nut could damage the steering bearings.

- ◆ Tighten the adjusting nut (6) until all the bearing play is removed.
- ◆ Check the play as described above. Make sure that the front fork can move throughout its entire range, stop to stop, in a free and smooth rotation.
- ◆ Hold the adjusting nut (6) in position using the spanner wrench and tighten the lock nut (5). Check the bearing play again after you have tightened the lock nut to insure that the adjustment is maintained.

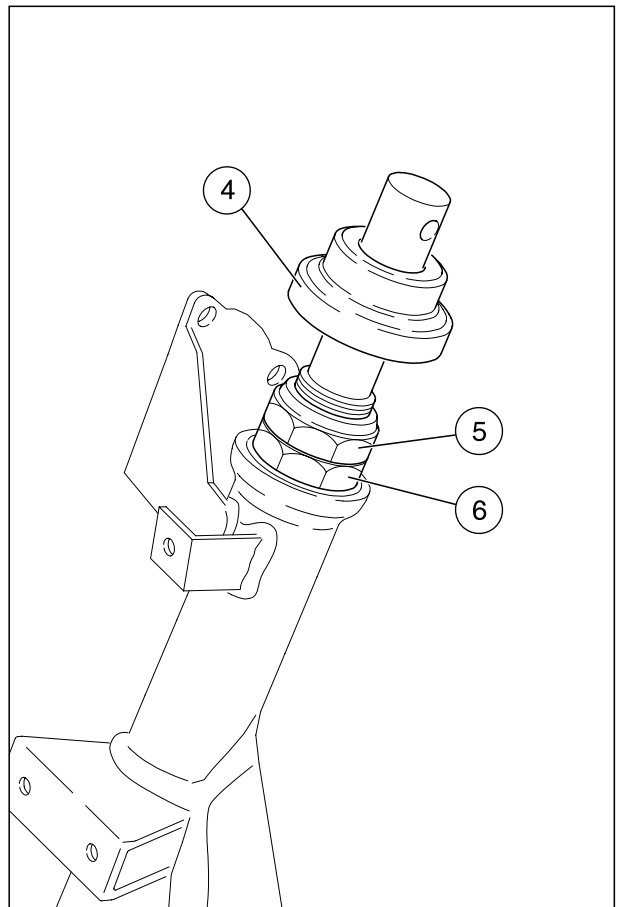

REMOVING THE FORK HEAD BEARINGS

Carefully read p. 2 (GENERAL SAFETY RULES).

⚠ WARNING

Put a proper support under the vehicle, in order to prevent it from falling down.

- ◆ Position the vehicle on the center stand, on a lifting platform, with the front wheel protruding from the platform edge.
- ◆ Lift the platform at 19.69 - 23.62 in (50-60 cm) from the ground, in order to be able to withdraw the fork together with the wheel without problems.
- ◆ Remove the brake line rubber guide and the speedometer cable rubber guide from the fender.
- ◆ Remove the front brake caliper, see p. 59 (REMOVING THE FRONT BRAKE CALIPER).
- ◆ Remove the cover (1).
- ◆ Unscrew the metal ring (2).
- ◆ Disconnect the speedometer cable from the speedometer drive (3).
- ◆ Remove the front inner shield, see p. 22 (REMOVING THE FRONT INNER SHIELD).
- ◆ Unscrew and remove the nut (4).
- ◆ Unscrew and remove the screw (5).
- ◆ Loosen the nut (6).

Nut tightening torque: 36.17 ftlb (50 Nm).

⚠ CAUTION

Do not force the cables, tubes, lines, connectors or wires.

- ◆ Withdraw the handlebars completely from the fork rod.
- ◆ Withdraw and remove the rubber gasket (7).
- ◆ Unscrew and remove the lock nut (8).

⚠ WARNING

Support the fork, in order to prevent it from accidentally falling down.

- ◆ Unscrew and remove the adjusting nut (9).

⚠ CAUTION

When removing the fork, be careful to capture all of the fork head bearing balls. They are not caged, and will fall free as the fork is removed.

- ◆ Remove the fork from the steering tube.
- ◆ Remove the inner race (10) and balls (11) from the upper bearing.
- ◆ Remove the inner race (12) and the balls (14) from the lower bearing.
- ◆ Carefully wash all of the bearing components, including the outer races (13) and (15).
- ◆ Inspect all components for wear, if necessary replace them.
- ◆ Liberally grease all bearing components, holding the balls in place in the outer race with the grease before attempting to assemble the fork by reversing the above procedure.

⚠ CAUTION

Upon reassembly, pay attention to the correct number of balls to be inserted:

- Upper bearing (11): # 21 balls.
- Lower bearing (14): # 25 balls.

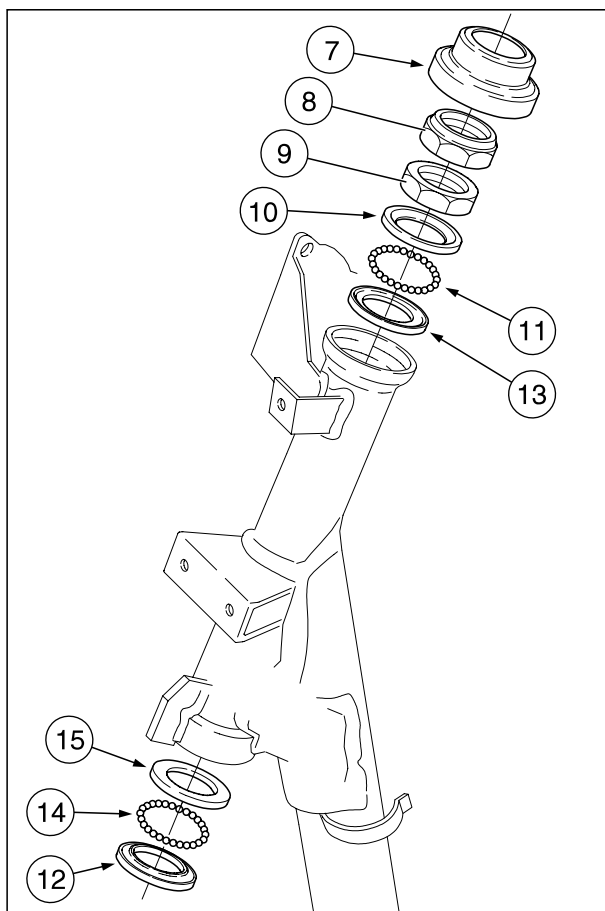
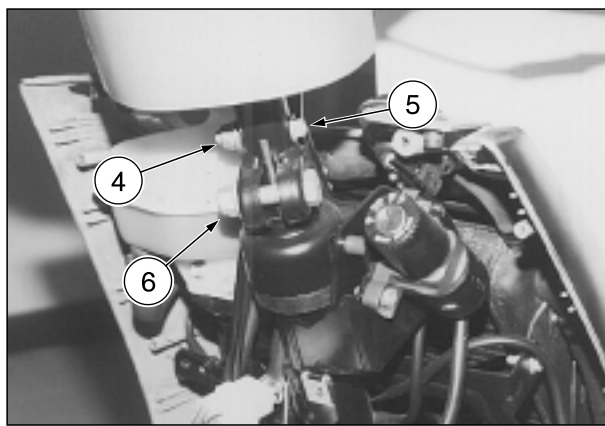
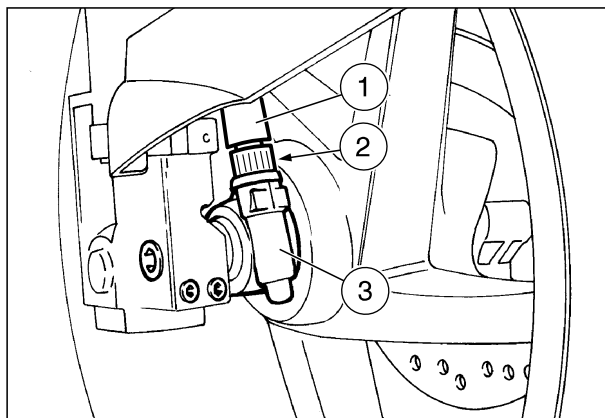

FRONT FORK

CHECKING THE FORK OIL LEVEL

Carefully read p. 2 (GENERAL SAFETY RULES).

The front fork is equipped with a hydraulic damper which depends upon a proper level of front fork oil to function properly and safely. If the fork bottoms during operation on normal roads, it is possible that the front fork oil level is too low. To check the front fork oil level proceed as follows:

- ◆ Place the vehicle on the center stand.
- ◆ Remove the front inner shield, see p. 22 (REMOVING THE FRONT INNER SHIELD).

NOTE To facilitate removing the two seal plugs (3), they both should be removed at the same time.

- ◆ ★ Remove the rubber plug (1).
- ◆ ★ Remove the snap ring (2).
- ◆ Push the fork slowly downwards until the two seal plugs (3), complete with O-rings, come out.

NOTE Check the condition of the O-rings and replace them if they are in any way damaged.

NOTE Check the position of the spring (5) (in its upper part, the diameter and the pitch of the coils must be shorter).

CAUTION

The spring is immersed in oil; let it drip thoroughly before removing it completely. Avoid dripping oil while removing the spring.

- ◆ ★ Remove the spring (5) completely after removing it partially and allowing oil to run from it.
- ◆ Pull the fork to the end of its stroke, and insert a rod or wire into the tube. Note the oil level. The distance between the top of the tube and the oil level should be 3.15 in ± 0,08 in (80±2 mm).
- ◆ If it is lower than this, top up the fork tube's using the lubricant suggested on the LUBRICANT CHART, p. 10.

These operations should be carried out for both tubes.

REMOVING THE COMPLETE FORK

To remove the complete fork (in case of replacement), keep to the instructions of p. 70 (REMOVING THE FORK HEAD BEARINGS);

REPLACE THE THREE OPERATIONS:

- ◆ Lift the protection element (1).
- ◆ Unscrew the metal ring (2).
- ◆ Disconnect the speedometer/odometer cable from the control on the wheel (3).

WITH THE FOLLOWING OPERATION:

- ◆ Remove the front wheel, see p. 54 (FRONT WHEEL - DISASSEMBLY).

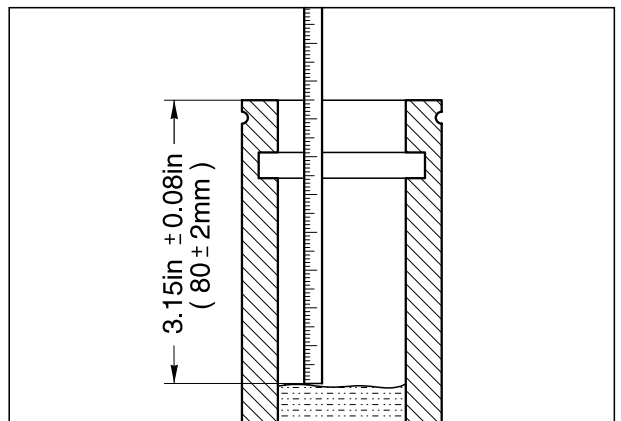
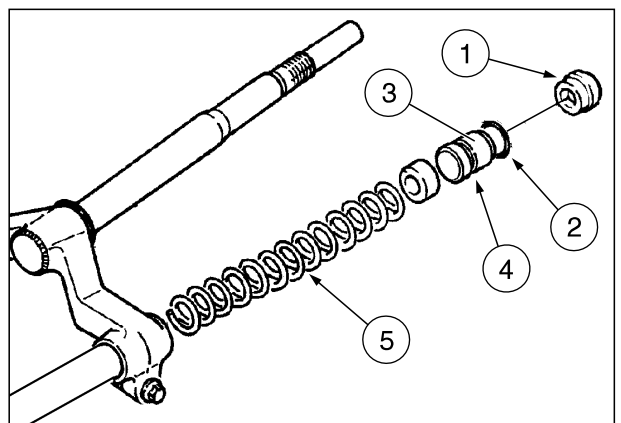
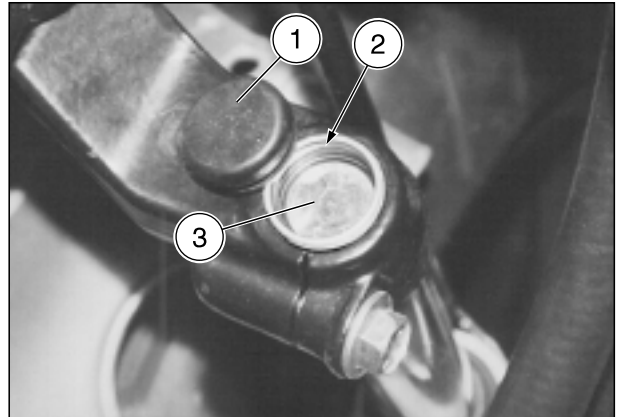

REMOVING THE LOWER FORK LEG (with installed fork)

Carefully read page 2 (GENERAL SAFETY RULES).

- ◆ Place the vehicle on the center stand.

⚠ WARNING

Put a proper support under the vehicle, in order to prevent it from falling down.

- ◆ Remove the front wheel, see p. 54 (FRONT WHEEL - DISASSEMBLY).
- ◆ Remove the front inner shield, see p. 22 (REMOVING THE FRONT INNER SHIELD).
- ◆ Loosen the bolt (6) in the fork head.
- ◆ Lift the fork tube up, displacing it as far as necessary to remove the snap ring (7).
- ◆ Lower the fork tube together with the lower fork leg and remove it completely from the fork head.

DISASSEMBLING THE LOWER FORK LEG

Carefully read p. 2 (GENERAL SAFETY RULES).

- ◆ To disassemble the rubber plug (1), the retaining ring (seeger) (2), the seal plug (3) complete with O-ring (4) and the spring (5), carry out the operations described at p. 71 (CHECKING THE FORK OIL LEVEL), excluding the last two operations (oil level checking), on the lower fork leg that you want to disassemble.

⚠ CAUTION

The lower fork leg is full of oil, which will spill if the leg is turned over or inclined excessively during removal.

- ◆ Remove the lower fork leg unit, see above (REMOVING THE LOWER FORK LEG (with installed fork)).
- ◆ Obtain a graduated container of at least 10.14 US fl oz (300 cm³) capacity.

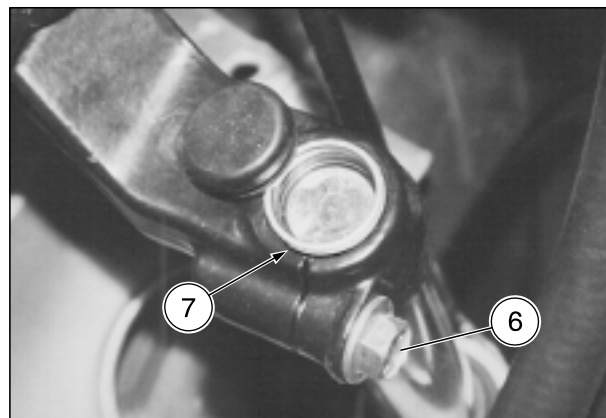

- ◆ Invert the fork tube lower fork leg assembly, open the container, and pump the tube in and out of the lower fork leg. This will cause most of the oil in the unit to drain into the container.

⚠ CAUTION

Check the oil quantity.

If it is less than 3.48 US fl oz (103 cm³) (per side), add make up oil.

- ◆ Remove the screw (8) from the bottom of the lower fork leg, along with the copper washer (9).
- ◆ Remove the fork tube (10) complete with the damper (11).
- ◆ Remove the snubber (13) and the rebound spring (14).
- ◆ Remove the dust seal (15).
- ◆ Remove the retaining ring (16).

⚠ CAUTION

Upon reassembly, position the retaining ring (seeger) (16) with its sharp edge resting against the adjacent elements (see figure).

- ◆ Remove the seal (17).

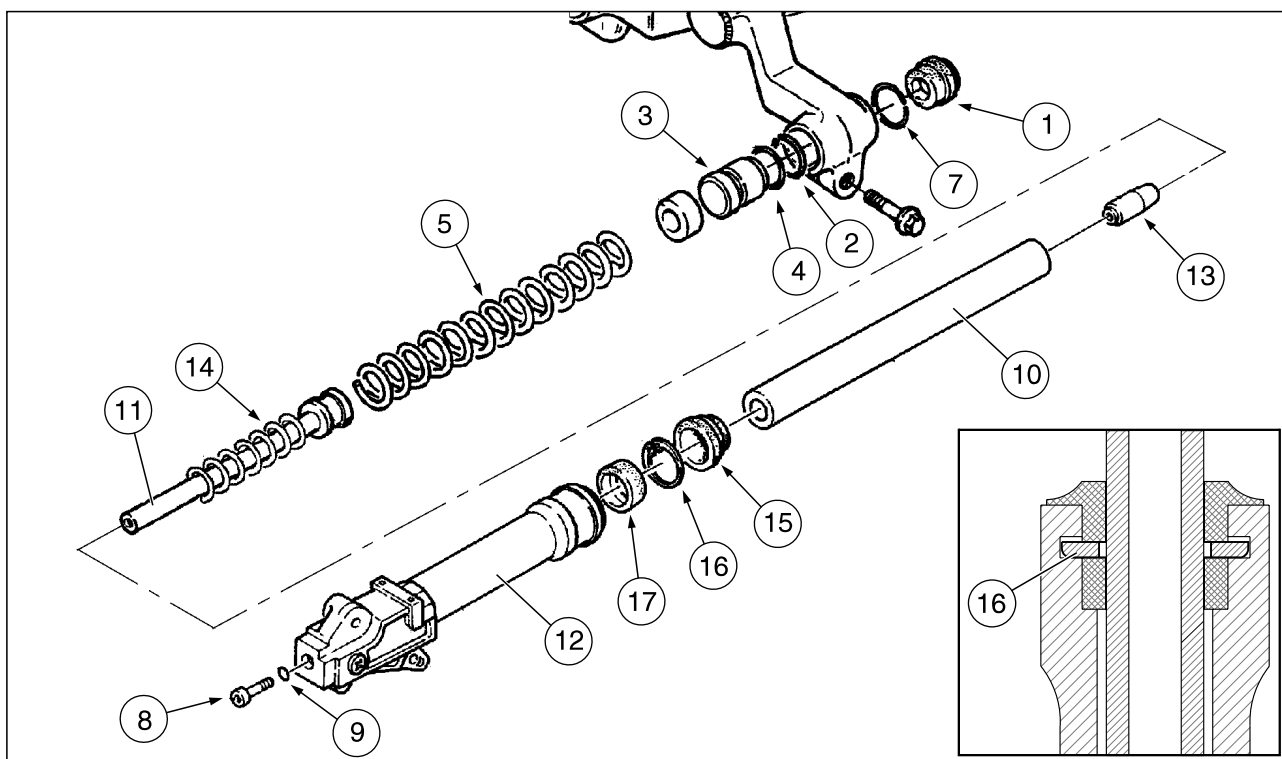

REAR SUSPENSION

Carefully read page 2 (GENERAL SAFETY RULES).

REMOVAL

- ◆ Place the vehicle on the center stand.

⚠ CAUTION

Place a suitable spacer under the rear wheel to prevent it from dropping too far and thus forcing the air cleaner casing into the inspection cover.

- ◆ Remove the cover of the rear part of the fairing, see p. 27 (REMOVING THE COVER OF THE REAR PART OF THE FAIRING).

⚠ WARNING

Support the rear part of the frame to prevent it from dropping during the removal of the shock absorber.

- ◆ Remove the upper screw (2) and washer.
Upper screw tightening torque: 36.17 ftlb (50 Nm).
- ◆ Remove the lower screw (1) and washer.
Lower screw tightening torque: 18.08 ftlb (25 Nm).
- ◆ Remove the shock absorber (3).

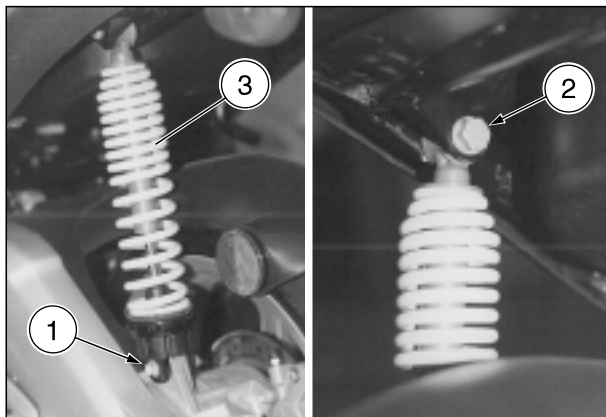

EXHAUST SILENCER

Carefully read page 2 (GENERAL SAFETY RULES).

DISASSEMBLY

- ◆ Place the vehicle on the center stand.

⚠ WARNING

Before carrying out the following operations, let the engine and the exhaust silencer cool down until they reach room temperature, in order to avoid burns.

⚠ CAUTION

If the additional flange (4) is provided, do not unscrew the screws (5) and (6), but follow the procedure described here below.

- ◆ Unscrew and remove the screws (7) and (8).
Screw (7) and (8) tightening torque: 7.23 ftlb (10 Nm).
- ◆ Unscrew and remove the two screws (9) and (10) that fasten the exhaust silencer to the engine.
Screw (9) and (10) tightening torque: 18.08 ftlb (25 Nm).
- ◆ Remove the exhaust silencer.
- ◆ Taking the two bushings of the upper screw (9).

NOTE Upon reassembly, replace the gasket positioned between the exhaust manifold and the silencer with a new one.

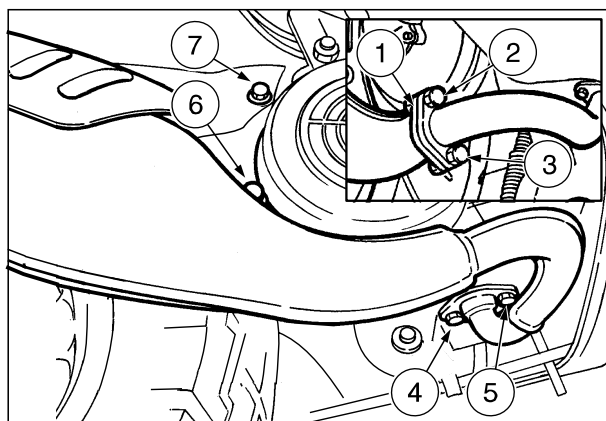

AIR CLEANER

Carefully read page 2 (GENERAL SAFETY RULES).

⚠ WARNING

Do not use gasoline or inflammable solvents to wash the air cleaner, in order to avoid fires or explosions.

Check the conditions of the air cleaner and clean it monthly or every 2,500 mi (4,000 km), depending on the conditions in which the vehicle is used.

If the vehicle is used on dusty or wet roads, the cleaning operations and any replacement should be carried out more frequently.

Before the cleaning operation, it is necessary to remove the air cleaner from the vehicle.

REMOVAL

- ◆ Remove the lower shield cover, see p. 20 (REMOVING THE LOWER SHIELD COVER).
- ◆ Remove the left inspection cover, see p. 20 (REMOVING THE RIGHT AND LEFT INSPECTION COVERS).
- ◆ Remove the screw (1) and the washer and the breather pipe ring (2).
- ◆ Unscrew and remove the screw (3) with the relevant washer.
- ◆ Loosen the screw (4) of the air manifold clamp.
- ◆ Grasp the air manifold complete with the clamp, and pull it away, thus removing the whole air cleaner casing.

CLEANING THE AIR FILTER

- ◆ Unscrew the three screws (5).
- ◆ Remove the filter case cover (6) and remove the filter element.
- ◆ To clean the filter element, rinse it in non-flammable solvent, then allow it to dry thoroughly.
- ◆ Sparingly apply filter oil, or heavy engine oil (SAE 80W-90), then squeeze the filter to eliminate any excess oil.

NOTE The filter must be completely wet with oil, but not dripping.

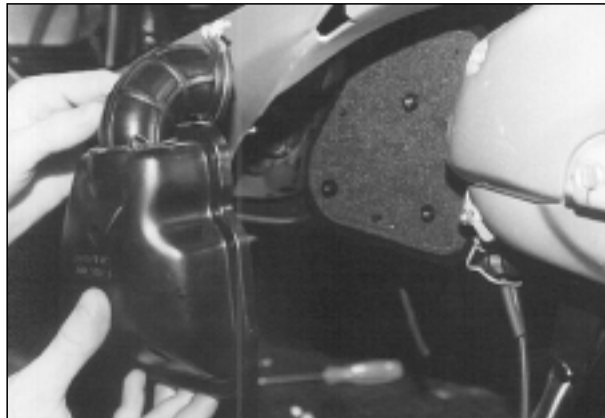
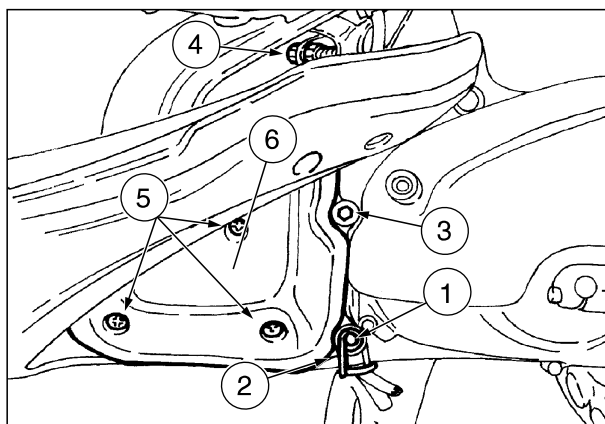

IGNITION SWITCH / STEERING LOCK

REMOVAL

- ◆ Remove the front inner shield, see p. 22 (REMOVING THE FRONT INNER SHIELD).
- ◆ Disconnect the two electric connectors (7) and (8).
- ◆ Unscrew and remove the screws (9).
- ◆ Remove the switch.

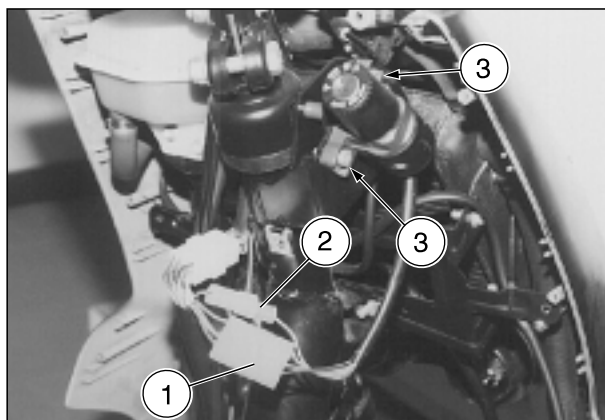

BATTERY

Carefully read page 2 (GENERAL SAFETY RULES).

Check the electrolyte level and the tightness of the terminals after the first 300 mi (500 km) and successively every 2,500 mi (4,000 km) or 8 months.

⚠ WARNING

Batteries, when charged, give off hydrogen gas, which is highly explosive. Therefore, do not smoke while working on or around the battery, and keep naked flames or sparks away from the battery. Keep gasoline and other flammable substances well away from the battery, since a battery spark could easily ignite them and cause a devastating fire.

Battery electrolyte is toxic and caustic and can severely burn your eyes or skin. Always wear tight fitting goggles and protective clothing when handling battery electrolyte. It is particularly important for you to protect your eyes since even a minuscule amount of battery acid could destroy your vision.

Should you accidentally get even the smallest amount of battery electrolyte on your skin or eyes, immediately flush with large quantities of clear cool water and immediately seek professional medical attention.

If someone should accidentally swallow battery electrolyte, drink a large quantity of milk or cool clear water and continue with milk of magnesia or vegetable oil. Seek professional medical assistance immediately.

Since the battery gives off explosive hydrogen gas, especially when it is being charged, when you are charging a battery, make sure that the room is properly ventilated. Do not inhale the gases released during charging. Do not permit any open flames, sparks or cigarettes or any other source of heat anywhere near the battery while it is charging.

KEEP AWAY FROM CHILDREN

Do not tip the vehicle too much, or tip the battery too much, to avoid electrolyte leaking out. Should you accidentally spill battery electrolyte on any part of your vehicle, immediately wash it off with lots of cool clear water. Spills may be neutralized with a mixture of baking soda and water, as well. This is particularly important, as the battery electrolyte will severely corrode metallic parts and destroy the finish of plastic and painted parts.

⚠ CAUTION

Never invert the battery cables. Observe the proper polarity of the battery. Incorrectly attaching the battery to your vehicle will irreparably destroy the electrical system of your vehicle.

Connect and disconnect the battery only with the ignition switch (1) in the "⊗" (OFF) position.

First connect the positive cable (red) (+), then the negative (-).

Disconnect the negative cable (-) first, then the positive (red) (+).

If your battery needs to be charged, use a constant voltage, or "taper" charger, with a current rating no greater than 1/10th the capacity of the battery (i.e., for a 50 amp hour battery, the maximum charging current should be 5 amps). Use of a more powerful charger can not only damage the battery irreparably, but could cause it to overheat and explode.

If your battery is equipped with an overflow tube, always ensure that it is properly installed, and properly routed. Failure to adhere to this instruction can cause corrosive fumes from the battery to cause serious damage to your vehicle.

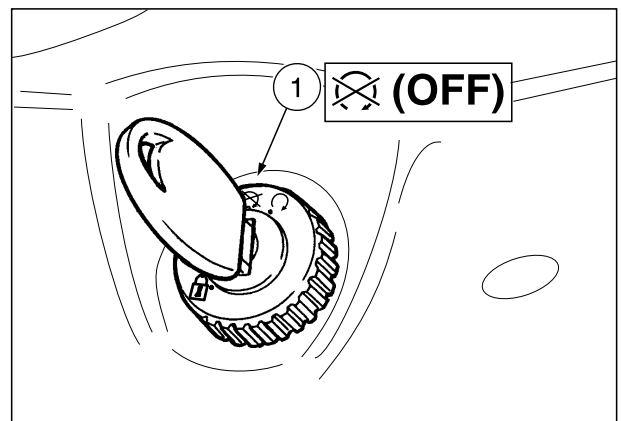
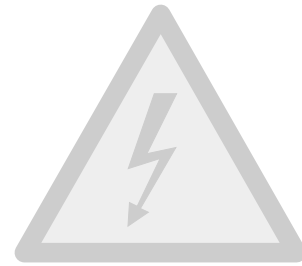

BATTERY STORAGE

If your vehicle remains unused for more than a couple of weeks, it will be necessary to "trickle charge" the battery, to prevent battery damage, see p. 77 (RECHARGING THE BATTERY).

- ◆ Remove the battery, see below (REMOVING THE BATTERY), and put it in a cool, dry place.
- ◆ The best way to prevent battery deterioration is to constantly leave a "trickle" charger with a capacity of about 1/10th amp, attached. These chargers are very economically, and will ensure that the battery always remains in tip top condition.
- ◆ If this cannot be done, charge the battery for about 30 minutes using a battery charger with a current capacity of no greater than 1/10th the capacity of the battery, see p. 77 (RECHARGING THE BATTERY).
- ◆ While we recommend removing the battery from the vehicle, if you must leave it in your vehicle, disconnect both battery cables.

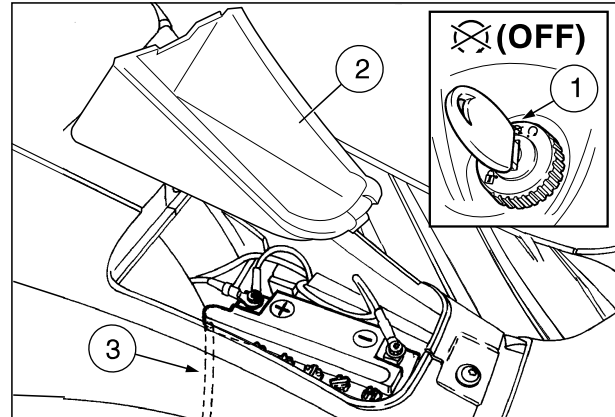

CHECKING AND CLEANING THE TERMINALS

Carefully read p. 75 (BATTERY).

- ◆ Remove the battery/tool kit compartment cover, see p. 21 (REMOVING THE BATTERY / TOOL KIT COMPARTMENT COVER).
- ◆ Remove the tool kit compartment (1).
- ◆ Make sure that the cable terminals (2) and the battery terminals (3) are:
 - in good conditions (and not corroded or covered with deposits);
 - covered with neutral grease or Vaseline.

If it is necessary to clean the battery terminals:

- ◆ Make sure that the ignition switch (4) is in "⊗" (OFF) position.
- ◆ Disconnect first the negative (–) and then the positive cable (red) (+).
- ◆ Brush with a wire brush to eliminate any sign of corrosion.
- ◆ Reconnect first the positive cable (red) (+) and then the negative cable (–).
- ◆ Cover the terminals of the cables and of the battery with neutral grease or Vaseline.

After these operations:

- ◆ Replace the tool kit compartment (1).
- ◆ Replace the battery / tool kit compartment cover, see p. 21 (REMOVING THE BATTERY / TOOL KIT COMPARTMENT COVER).

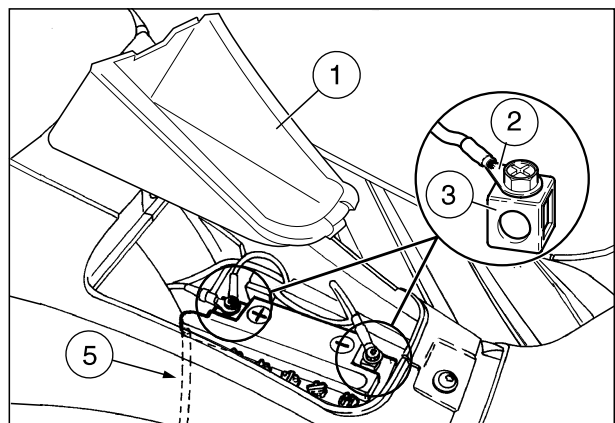

REMOVING THE BATTERY

Carefully read p. 75 (BATTERY).

- ◆ Make sure that the ignition switch (4) is in "⊗" (OFF) position.
- ◆ Remove the battery/tool kit compartment cover, see p. 21 (REMOVING THE BATTERY / TOOL KIT COMPARTMENT COVER).
- ◆ Remove the tool kit compartment (1).
- ◆ Disconnect first the negative (–) and then the positive cable (red) (+).
- ◆ Remove the battery breather tube (5) (breather tubes are not fit to maintenance free batteries).
- ◆ Remove the battery from its compartment and put it on a flat surface, in a cool and dry place.

⚠ WARNING

Once it has been removed, the battery must be stored in a safe place and kept away from children: risk of serious injuries or even death.

- ◆ Replace the tool kit compartment (1).
- ◆ Replace the battery/tool kit compartment cover, see p. 21 (REMOVING THE BATTERY / TOOL KIT COMPARTMENT COVER).

CHECKING THE ELECTROLYTE LEVEL
(ONLY FOR BATTERIES THAT NEED MAINTENANCE)

Carefully read p. 75 (BATTERY).

NOTE The following section does not apply to maintenance free batteries.

Carefully read p. 75 (BATTERY).

To check the electrolyte level, proceed as follows:

- ◆ Remove the battery, see p. 76 (REMOVING THE BATTERY).
- ◆ Make sure that the fluid level falls between the “MIN” and “MAX” notches stamped on the side of the battery. If it does not:
- ◆ Remove the battery plugs.

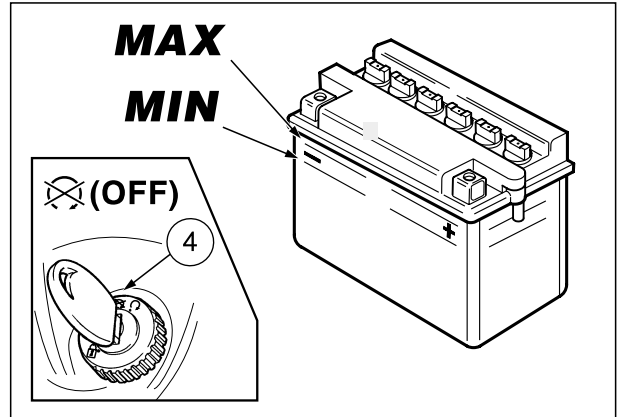

CAUTION

Top up with distilled water only. Do not exceed the “MAX” mark, since the electrolyte level increases during the recharge.

- ◆ Top up by adding distilled water.

CAUTION

After topping up, replace the battery plugs in the correct position.

- ◆ Replace the battery plugs.

RECHARGING THE BATTERY
(ONLY FOR BATTERIES THAT NEED MAINTENANCE)

Carefully read p. 75 (BATTERY).

NOTE The following section does not apply to maintenance free batteries.

Carefully read p. 75 (BATTERY).

- ◆ Remove the battery, see p. 76 (REMOVING THE BATTERY).
- ◆ Remove the battery plugs.

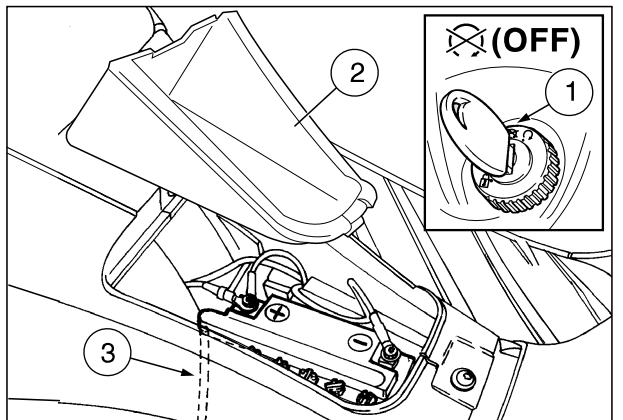

WARNING

The battery gives off noxious and explosive gases; keep it away from flames, sparks, cigarettes and any other source of heat.

During the recharging or the use, make sure that the room is properly ventilated and avoid inhaling the gases released during the recharging.

- ◆ Check the electrolyte level, see above (CHECKING THE ELECTROLYTE LEVEL).
- ◆ Connect the battery charger to the battery.
- ◆ Charge the battery using a battery charger with a current capacity of no greater than 1/10th the capacity of the battery, see p. 9 (TECHNICAL DATA).
- ◆ After the recharging operation, check the electrolyte level again and if necessary top up with distilled water.

CAUTION

Do not replace the battery plugs until 10 minutes after disconnecting the charger, since the battery continues to produce gas after the charger is removed.

- ◆ Replace the battery plugs.

INSTALLING THE BATTERY

Carefully read p. 75 (BATTERY).

- ◆ Make sure that the ignition switch (1) is in the “OFF” position.
- ◆ Remove the battery/tool kit compartment cover, see p. 21 (REMOVING THE BATTERY / TOOL KIT COMPARTMENT COVER).
- ◆ Remove the tool kit compartment (2).
- ◆ Put the battery in its container.

CAUTION

Reconnect the battery breather tube (3), see p. 75 (BATTERY).

- ◆ Connect the battery breather tube (3) (not applicable to maintenance free batteries).
- ◆ Connect, in order, the positive (red) (+) and negative (–) cable.
- ◆ Cover the terminals of the cables and of the battery with neutral grease or Vaseline.
- ◆ Replace the tool kit compartment (2).
- ◆ Replace the battery/tool kit compartment cover, see p. 21 (REMOVING THE BATTERY / TOOL KIT COMPARTMENT COVER).

ENGINE**REMOVING THE ENGINE FROM THE FRAME**

Carefully read page 2 (GENERAL SAFETY RULES).

- ◆ Place the vehicle on the center stand.
- ◆ Remove the rear part of the fairing, see p. 19 (REMOVING THE REAR PART OF THE FAIRING).
- ◆ Remove the inspection covers, see p. 20 (REMOVING THE RIGHT AND LEFT INSPECTION COVERS).
- ◆ Remove the crash helmet compartment, see p. 25 (REMOVING THE CRASH HELMET COMPARTMENT complete with saddle).
- ◆ Withdraw the spark plug cap.
- ◆ Disconnect the electric connectors of the starter (1) and of the CDI (2) and (3).
- ◆ Open the ring (4) as much as necessary and release the wires of the electric connectors (2) and (3).
- ◆ Loosen the intake manifold clamp screw (5).



⚠ CAUTION

Wash your hands carefully after handling the oil. Dispose of oil properly.

- ◆ Drain the 2 stroke oil tank (6) completely. Gather the oil in a container and plug it.
- ◆ Disconnect the filter (7) from the 2 stroke oil tank (6).

⚠ CAUTION

Upon reassembly, fill the tank and bleed the 2 stroke oil, see p. 34 (BLEEDING THE 2 STROKE OIL TANK).

- ◆ Disconnect the 2 stroke oil delivery tube from the carburetor and plug it.
- ◆ Remove the screw (8) and the washer and breather pipe ring (9).
- ◆ Remove the screw (10).
- ◆ Release the carburetor together with the air cleaner from the intake manifold.
- ◆ Remove the rear brake caliper, see p. 60 (REMOVING THE REAR BRAKE CALIPER).
- ◆ Tie the brake caliper onto the vehicle frame.
- ◆  Unscrew and remove the rear brake adjuster (11).
- ◆  Withdraw the brake cable, releasing it completely.

⚠ CAUTION

Put a proper spacer under the rear wheel to prevent it from falling and pushing the air cleaner casing into the frame.

- ◆ Remove the shock absorber lower screw (12) and washer.

Screw tightening torque: 18.08 ftlb (25 Nm).

- ◆ Rotate the shock absorber and tie it to the frame.

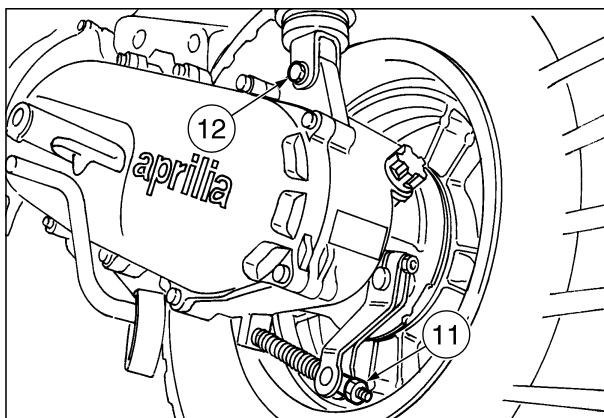
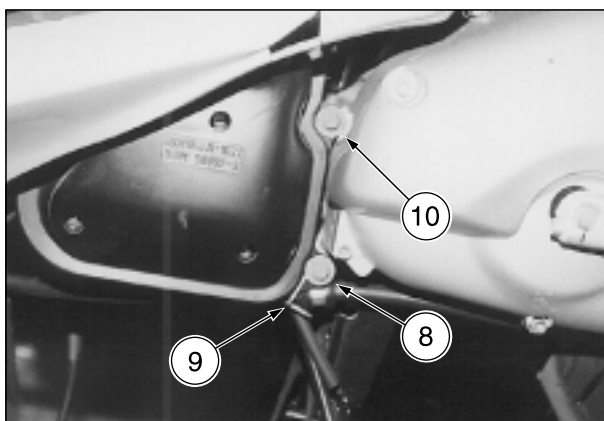
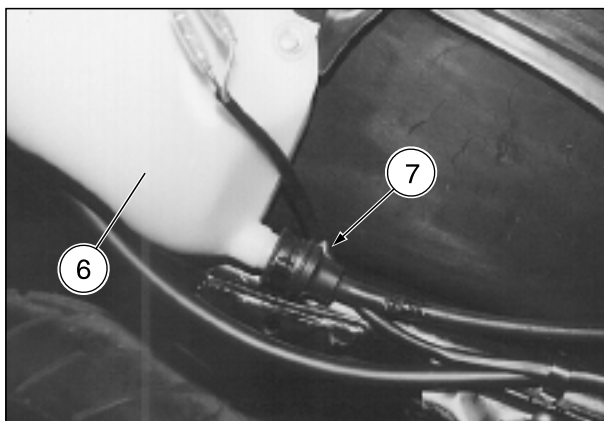
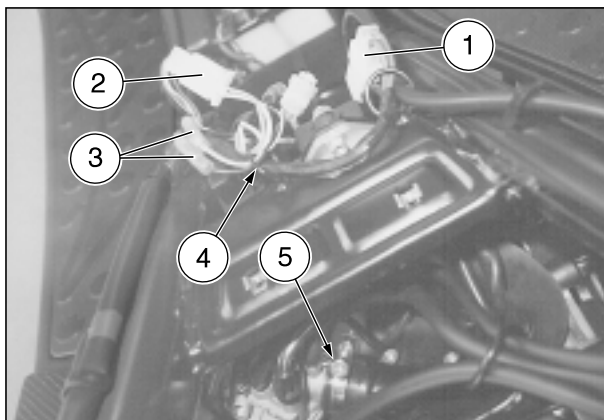

- ◆ Remove the screw (13), washer and bushing.
- ◆ Remove the two screws (14), washers and bushings.
- ◆ Remove the screw (15) and the special washer.
- ◆ Remove the transmission cover (16).
- ◆ Remove the engine fulcrum shaft nut (17) and washer.

Tightening torque of the engine fulcrum shaft nut: 36.17 ftlb (50 nm);

⚠ WARNING

To safely remove the engine, it is necessary to use a special (18) to support the vehicle chassis when the engine, rear wheel, exhaust silencer and center stand have been removed. This special tool is inserted between the frame members which carry the engine fulcrum shaft.

Due to the weight and size of the engine and the chassis, the following operations must be carried out by two people. The following procedure depends upon two mechanics, mechanic "A" and mechanic "B."

Be careful when you lift the vehicle. Its weight and size can cause dangerous unbalance as it is lifted which could cause it to tip over.

Proceed with great care and be sure that you can lift the weight of the vehicle.

- ◆ "A" lift the rear part of the vehicle by lifting on the frame.
- ◆ "B" completely remove the engine fulcrum shaft (19) and washer.

⚠ WARNING

Block the front wheel so it cannot move forward. If the front wheel rolls forward accidentally, it may steer to the side and cause the vehicle to become very unstable, creating a dangerous condition for both mechanics "A" and "B."

- ◆ Both "A" and "B" hold the handlebars and push the vehicle forward as much as necessary to clear the engine unit.
- ◆ "A" support the vehicle.
- ◆ "B" position the support (18) and insert the fulcrum pin (19).
- ◆ "A" lower the vehicle and insure that it is stable.

The engine, complete with engine fulcrum, shaft spacer (20), rear wheel and exhaust silencer will remain on the center stand.

⚠ WARNING

Handle with care. Take care not to crush your fingers, arms and legs. Be careful when lifting and moving the vehicle, since you may crush or bruise your fingers, arms, or legs when the stand returns to its rest position.

⚠ WARNING

Tape closed or plug the engine inlet manifold to prevent any accidental ingress of foreign matter.

- ◆ "A" and "B" Lift the engine complete with wheel, exhaust silencer and center stand and position it on the work bench.

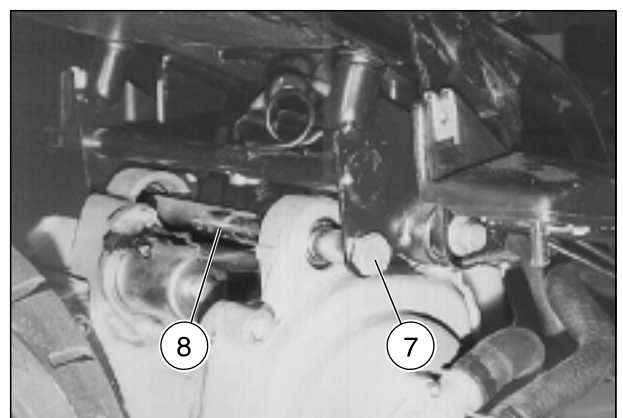
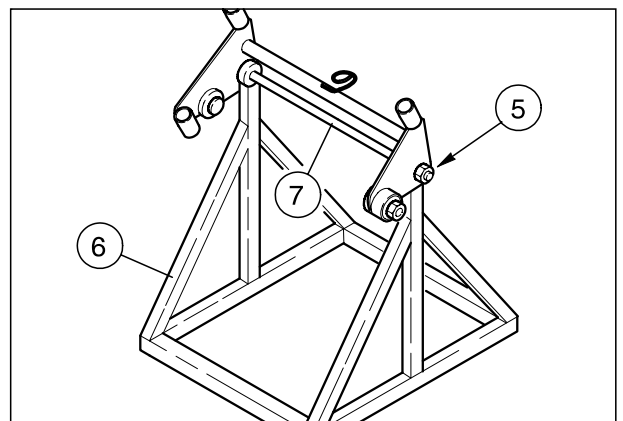
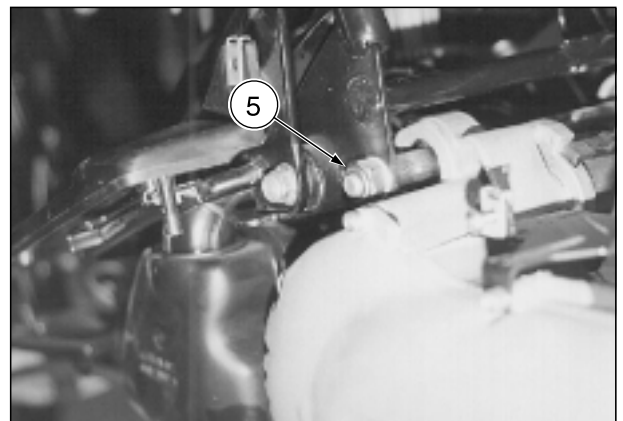
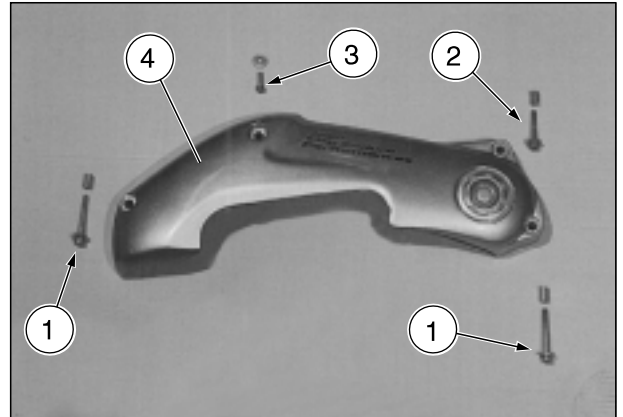

ENGINE (liquid-cooled version)

REMOVING THE ENGINE FROM THE FRAME

Carefully read page 2 (GENERAL SAFETY RULES).

- ◆ Drain the cooling system, see p. 37 (DRAINING THE COOLANT SYSTEM ).

NOTE Upon reassembly, change the coolant, see p. 38 (CHANGING THE COOLANT ).

CAUTION

Mark the pipes (1) and (2) to avoid confusing them during the reassembly.

NOTE Obtain screwdriver type worm gear hose clamp to replace the removed original equipment clamp.

- ◆ Cut the band of the hose clamps (1), (2), (3) and (4).

NOTE Upon reassembly, replace the hose clamps (1), (2), (3) and (4) with new ones.

- ◆ Mark the pipe (2) and withdraw it from the engine coupling.
- ◆ Disconnect the connector (5) of the coolant thermistor cable (6).

NOTE For the vehicles equipped with warmed carburetor, carry out the operations marked with "★".

CAUTION

Mark the pipes (9) and (10) to avoid confusing them during the reassembly.

NOTE ★ Get screwdriver-type pipe clamps, to replace the original ones (special type without screw).

- ◆ ★ Cut the head of the clamps (7) and (8).

NOTE ★ Upon reassembly, replace the pipe clamps (7) and (8) with new ones.

- ◆ ★ Mark the pipes (9) and (10) and withdraw them from the engine coupling.

- ◆ Remove the engine from the frame, see p. 78 (REMOVING THE ENGINE FROM THE FRAME).

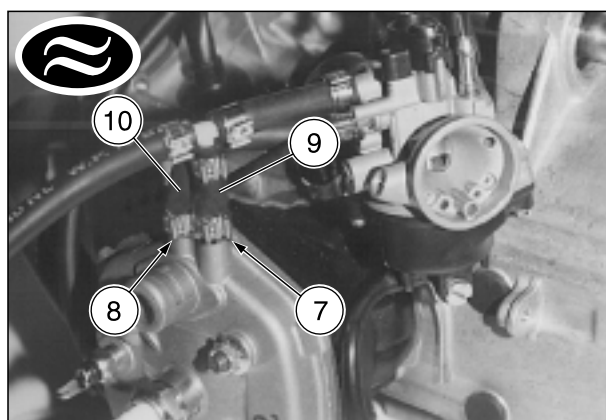
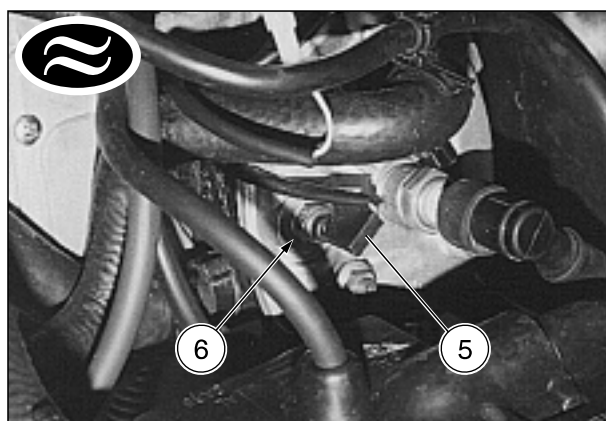
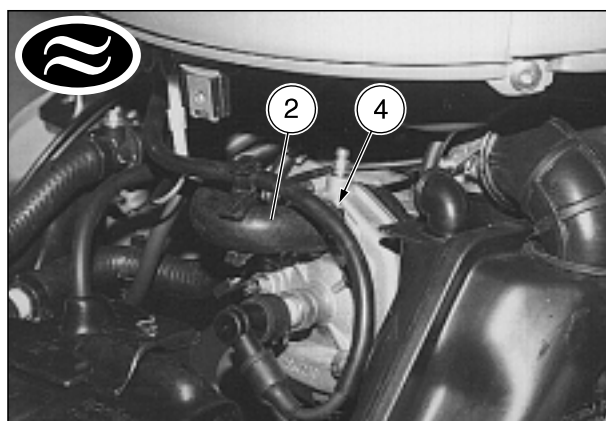
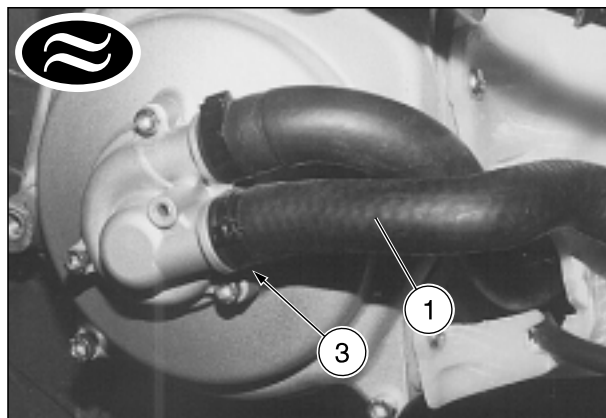



ENGINE MOUNTING BUSHINGS

REMOVAL

Carefully read page 2 (GENERAL SAFETY RULES).

Worn out or damaged bonded rubber engine mounting bushings can cause annoying vibration and unsafe vehicle handling.

To check the condition of the bushings, it is necessary to remove the engine mounting shaft (see figure below).

- ◆ Remove the lower shield, see p. 20 (REMOVING THE LOWER SHIELD COVER).
- ◆ Remove the engine, see p. 78 (REMOVING THE ENGINE FROM THE FRAME).
- ◆  Remove the engine, see p. 78 (REMOVING THE ENGINE FROM THE FRAME ).

⚠ WARNING

After removing the engine, support the vehicle chassis with the special support frame (1).

Position a support (1) [(height 11.81 in (300 mm))] under the central part of the frame.

⚠ WARNING

Check the stability of the vehicle.

- ◆ Remove the mounting shaft nut (2) and washer.

Connection engine mounting shaft nut tightening torque: 36.17 ftlb (50 Nm).

- ◆ Remove the shaft (3) and washer.
- ◆ Remove the support (1).
- ◆ ★ Unscrew and remove the nut (4) from the special bushing bolt (5) and washer.

Bushing nut (4) tightening torque: 30.38 ftlb (42 Nm)

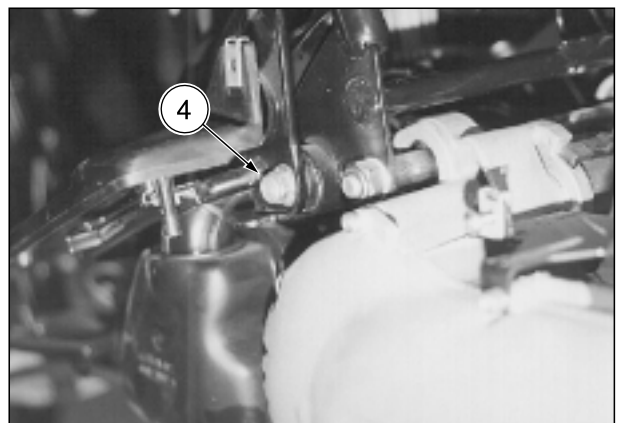
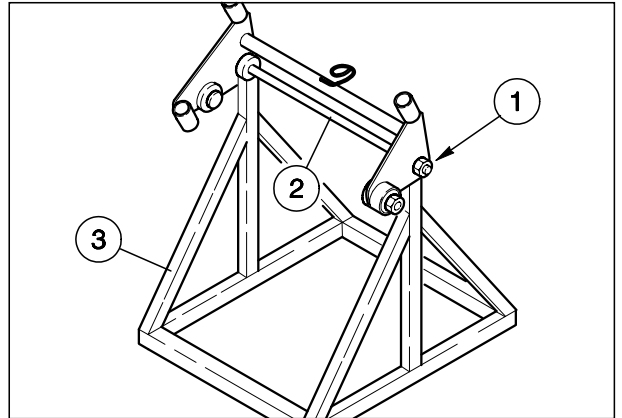

- ◆ ★ Remove the bushing bolt (5).
- ◆ Remove the connection link (6).
- ◆ Check the condition of the connection link (6), springs (7), spring seats (8) and snubbers (9). Replace if they are damage

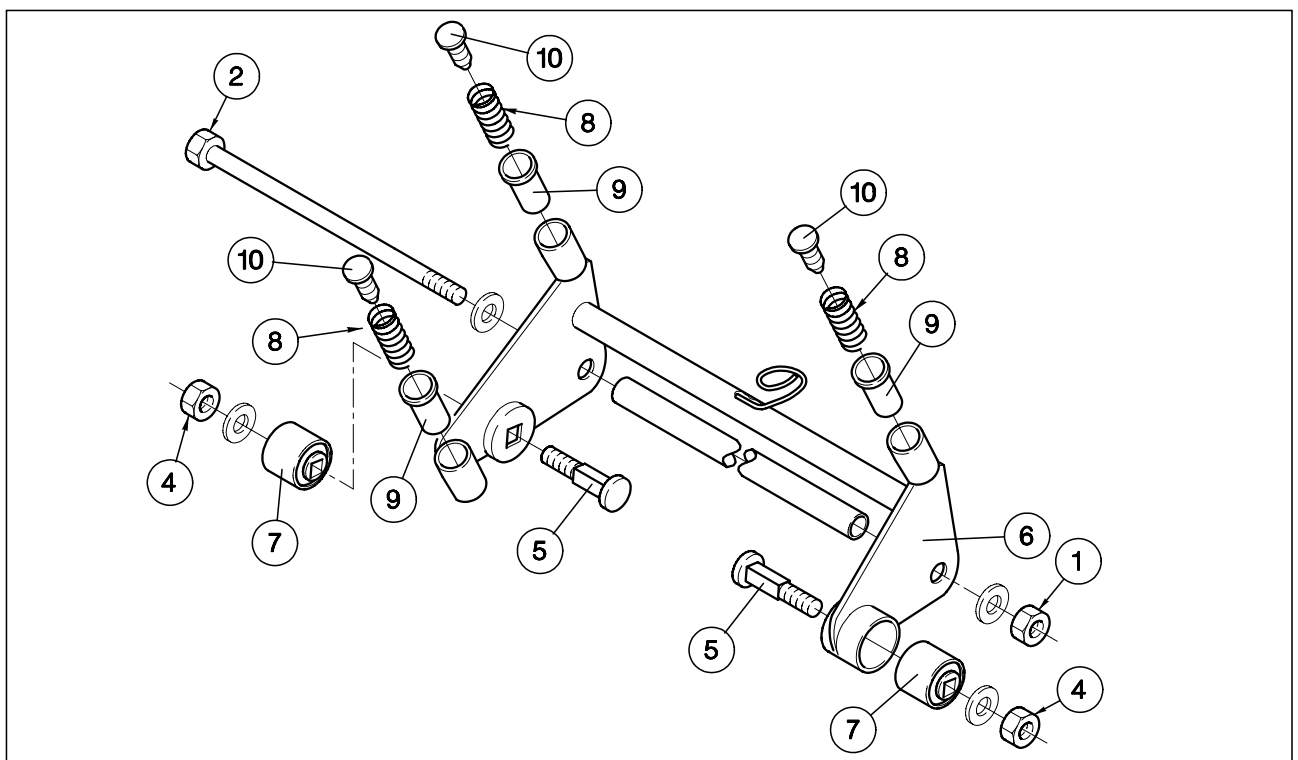



ELECTRICAL SYSTEM**CONTENTS**

A - Recommended equipment.....	82
B - Wiring diagram.....	83
C - Arrangement of the components.....	84
D - Ignition circuit	86
E - Recharge and general power supply circuit.....	87
F - Starting circuit	88
G - Sensor circuit	89
H - Direction indicator circuit.....	90
I - Horn circuit.....	91
J - Stoplight circuit.....	91
K - Lighting circuit.....	92
L - Coolant temperature indicator circuit 	93

A - RECOMMENDED EQUIPMENT

- Tester
- Battery electrolyte densimeter
- Stroboscopic gun for 2-stroke, 10000 rpm engines
- Direct current 0 ÷ 100 A amperometer
- 60 Ω 2 W resistance.

B - WIRING DIAGRAM**WIRING DIAGRAM KEY- SR 50 USA**
(air and liquid-cooled version )

- 1) Generator
- 2) CDI
- 3) Spark plug
- 4) H.T. coil
- 5) Voltage regulator
- 6) Battery
- 7) Starter
- 8) Start relay
- 9) Front stoplight switch
- 10) Rear stoplight switch
- 11) 2 stroke oil reserve switch
- 12) Front parking light bulb
- 13) Fuel level sensor
- 14) Rear right direction indicator
- 15) Rear light
- 16) Rear left direction indicator
- 17) Dimmer switch
- 18) Horn push button
- 19) Ignition switch/steering lock
- 20) Control diode
- 21) Coolant thermistor 
- 22) Blinking
- 23) Dashboard
- 24) Direction indicator warning light
- 25) 2 stroke oil reserve warning light
- 26) Dashboard light
- 27) Fuel level instrument
- 28) Low fuel warning light
- 29) High beam warning light
- 30) Coolant temperature instrument 
- 31) Front right direction indicator
- 32) Front left direction indicator
- 33) Front parking light
- 34) Low/high beam bulb
- 35) Horn
- 36) Pick up
- 37) Fuse
- 38) Multiple connectors
- 39) Rear parking light
- 40) Rear stoplight
- 41) Direction indicator switch
- 42) Starter button
- 43) License plate light
- 44) Engine stop switch

CABLE COLOURS

- | | |
|-----------|------------|
| Ar | orange |
| Az | light blue |
| B | blue |
| Bi | white |
| G | yellow |
| Gr | gray |
| M | brown |
| N | black |
| R | red |
| V | green |
| Vi | violet |
| Ro | pink |

WIRING DIAGRAM SR 50 USA (air and liquid-cooled version)

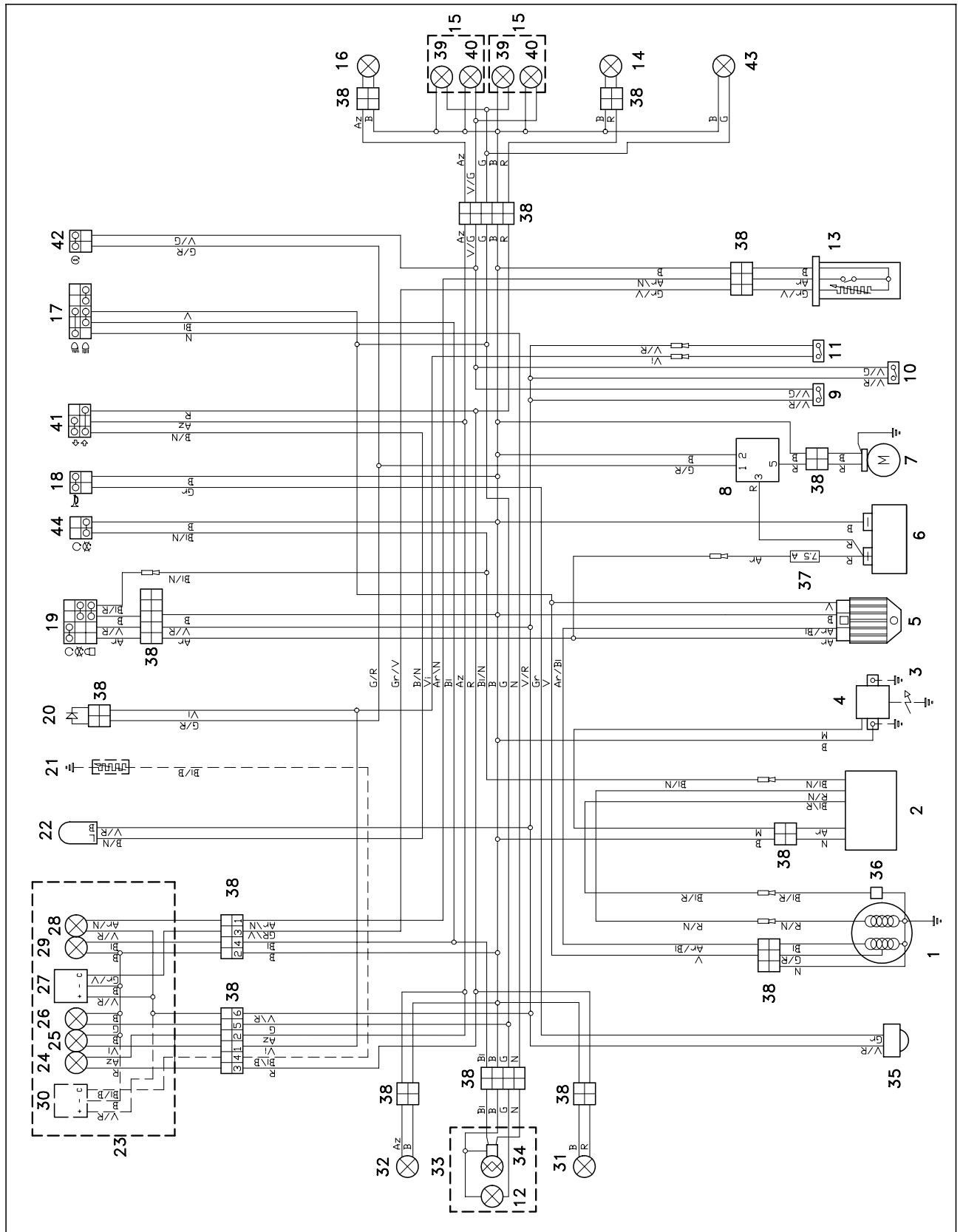

C - ARRANGEMENT OF THE COMPONENTS

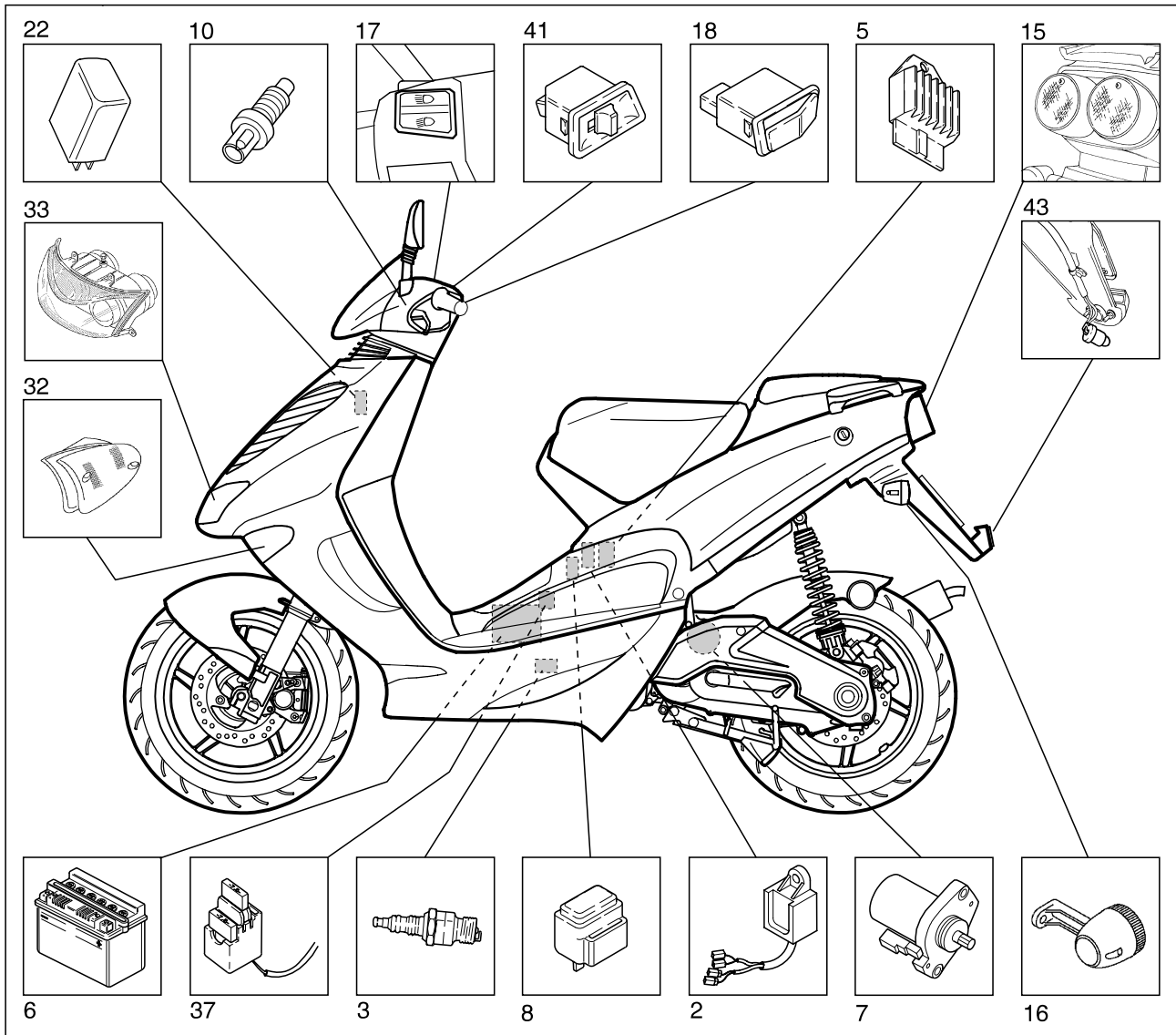
**KEY**

- 2) CDI
- 3) Spark plug
- 5) Voltage regulator
- 6) Battery
- 7) Starter
- 8) Starter relay
- 10) Rear stoplight switch
- 15) Rear light
- 16) Rear left direction indicator
- 17) Dimmer switch
- 18) Horn push button
- 22) Blinking
- 32) Front left direction indicator
- 33) Front parking light
- 37) Fuse
- 41) Direction indicator switch
- 43) License plate light

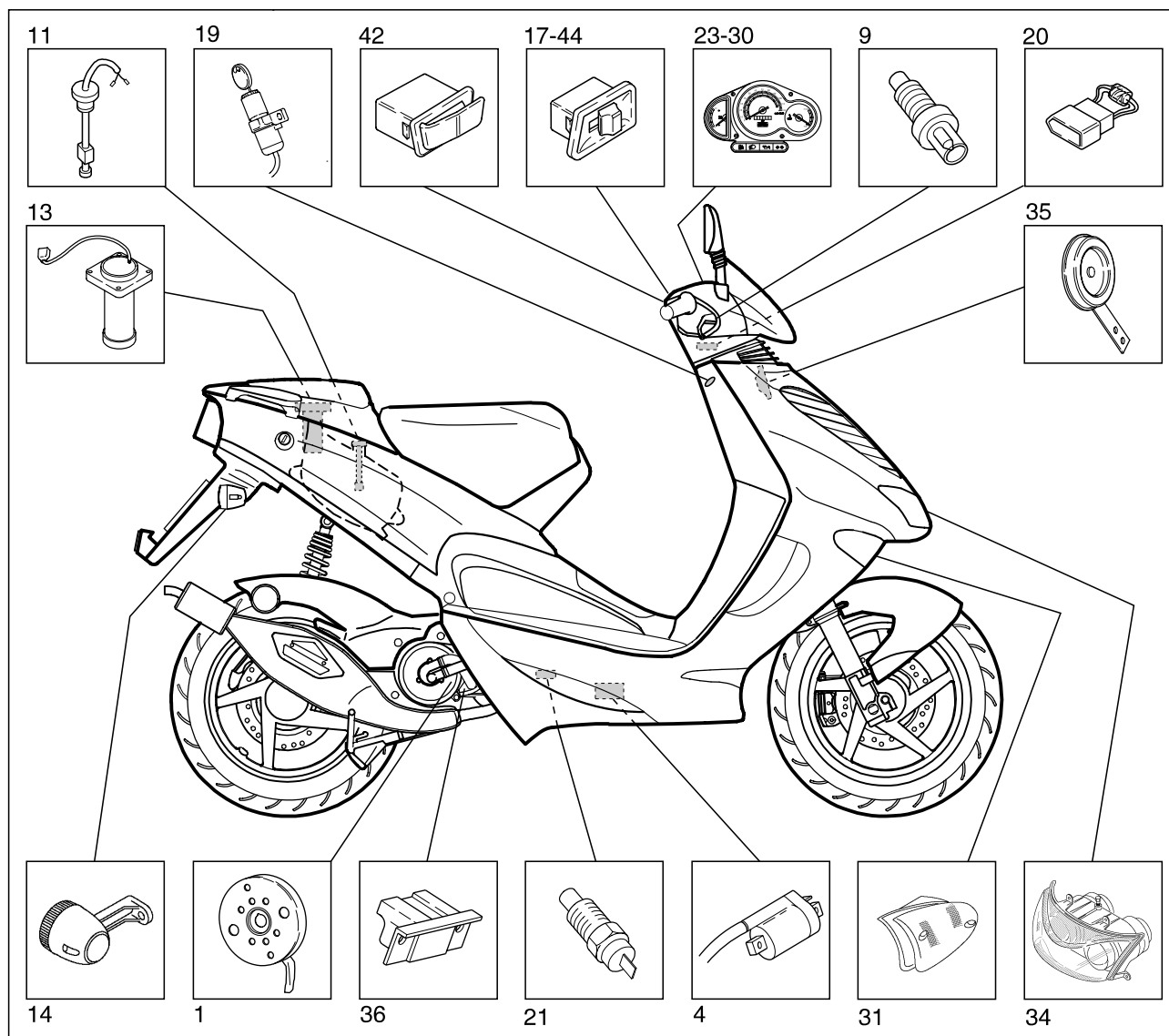

KEY

- 1) Generator
- 4) H.T. coil
- 9) Front stoplight switch
- 11) 2 stroke oil reserve switch
- 13) Fuel level sensor
- 14) Rear right direction indicator
- 19) Ignition switch / steering lock
- 20) Control diode
- 21) Coolant thermistor
- 23) Dashboard
- 27) Fuel level instrument
- 30) Coolant temperature instrument
- 31) Right front direction indicator
- 34) Low/high beam bulb
- 35) Horn
- 36) Pick-up
- 42) Start button
- 44) Engine stop switch

D - IGNITION CIRCUIT

WIRING DIAGRAM

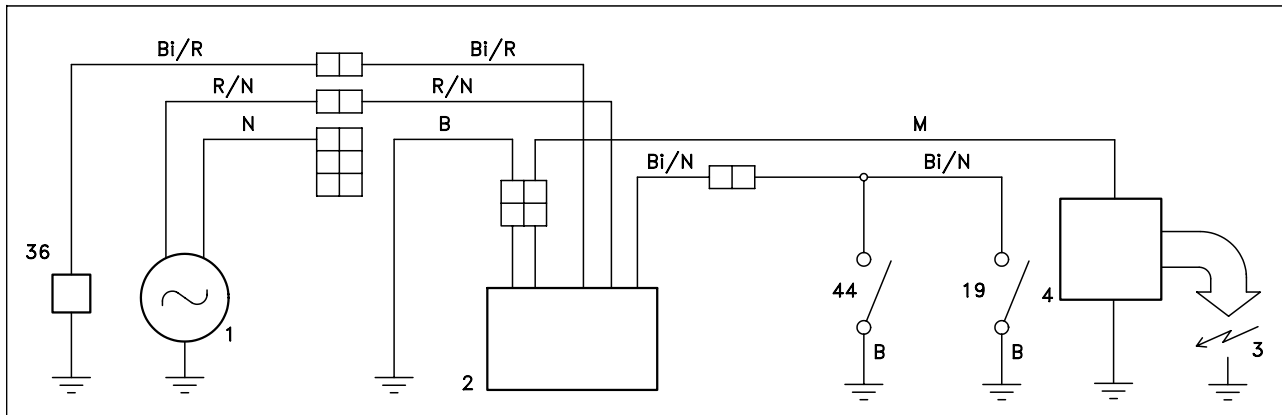

Arrangement of the components:
see p. 84 - 85.

- 1) Generator
- 2) CDI
- 3) Spark plug
- 4) H.T. Coil
- 19) Ignition switch
- 36) Pick-up
- 44) Engine stop switch

TECHNICAL DATA

Spark plug NGK BR7 HS
 Spark plug NGK BR8 HS
 Spark plug gap 0.020-0.024 in
 (0.5-0.6 mm)
 Spark advance 14° ± 2° before TDC
 Ignition CDI

TROUBLESHOOTING

A. ENGINE DOES NOT RUN REGULARLY OR THERE IS NO SPARK

- Check and if necessary replace the spark plug.
- Disconnect the white-black cable from the CDI, making sure that this doesn't accidentally get grounded.
- Check the cable connections.

If the fault persists:

- Check the high voltage cable.
- Check the spark plug cap.
- Check the ignition coil (p. 86).
- Check the ignition flywheel
- Replace the CDI with a new one.

If the fault disappears:

- Check the ignition switch (p. 86).
- Check the stop switch (p. 86).

B. ENGINE DOESN'T STOP

- Check the connection between ignition switch and white-black cable.

SPECIFICATIONS

Using an ohmmeter tester, check the continuity between the various cables. Pay careful attention to indicated polarity.

IGNITION FLYWHEEL

Pick-up coil:
between red/white cable and ground
500 Ω ± 20%.

Condenser charge coil:
between black/red cable and ground 800 Ω ± 20%.

IGNITION SWITCH

- Disconnect the ignition switch connector.
- Using an ohmmeter tester, check the continuity of the various circuits with the ignition switch in each of its positions, see p. 82 (B - WIRING DIAGRAM).

STOP SWITCH

- Disconnect the stop switch connector.
- Using an ohmmeter tester, check the continuity of the cables with the stop switch in OFF and ON positions, see p. 82 (B - WIRING DIAGRAM).

IGNITION COIL

- Primary winding: between spade connector and ground 0.7 ohms ± 20%.
- Secondary winding: between spark plug cable and ground 5 kiloohms ± 25%.

NOTE Before performing the above-mentioned checking, remove the spark plug cap.

E - RECHARGE AND GENERAL POWER SUPPLY CIRCUIT

WIRING DIAGRAM

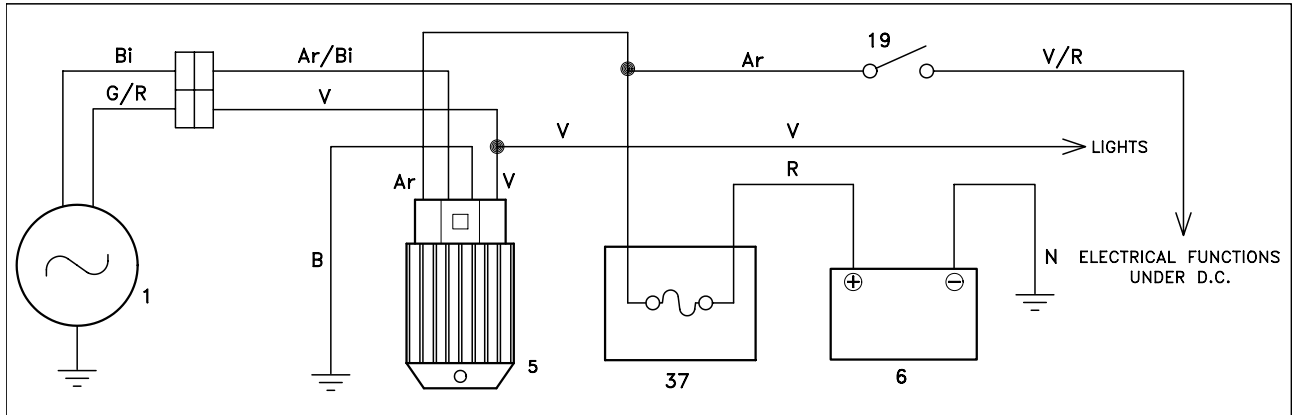

Arrangement of the components:
see p. 84 - 85.

- 1) Generator
- 5) Voltage regulator
- 6) Battery
- 19) Ignition switch/ steering lock
- 37) Fuse

TECHNICAL DATA

Generator 85W a.c. at 6000 rpm
Voltage regulator 12 V a.c.
Battery 4 Ah - 12V
Fuse..... 7.5 A

CHECKING THE CHARGING SYSTEM

- Start the engine.
- Connect a direct current voltmeter-tester to the battery terminals.
- At 6000 rpm voltage must be included between 13.5 and 15 volts, with low beams on.

TROUBLESHOOTING

A. INSUFFICIENT RECHARGE VOLTAGE

- Check the fuse and, if necessary, replace it.
- Check the cable connections on regulator, flywheel, battery and fuse.
- Check the battery (p. 87).
- Check the generator (p. 87).

B. EXCESSIVE RECHARGE VOLTAGE

- Check the voltage regulator (p. 92).
- Check the cable connections.

C. IF NO VOLTAGE REACHES THE LOADS UNDER DIRECT CURRENT (green/red cables)

- Check the fuse and if necessary replace it.
- Check the ground connections on regulator, flywheel, battery and fuse.
- Check the battery (p. 87).
- Check the generator (p. 87).
- Check the ignition switch (p. 86) and its connections.

D. IF THE SYSTEM FUNCTIONS IRREGULARLY

- Check the earth connections.

TEST DATA

GENERATOR

- Disconnect the three-way connector from the generator.
- Start the engine and bring it to 6000 rpm.
- Using an alternating current volt meter tester, measure voltage between:
 - white cable and generator earth = value over 41.2 V.
 - yellow/red cable and generator earth = value over 35 V.
- Using an alternating current ammeter tester, measure current between:
 - white cable and generator earth = value 8 ÷ 10 A.
 - yellow/red cable and generator earth = value 8 ÷ 10 A.

BATTERY

- No-load voltage 12.5 ± 1V.
- Electrolyte density 1.26 at 20 °C
- Check the electrolyte level and if necessary top up with distilled water.
- Make sure that there are no signs of sulphation. Replace if necessary.

F - STARTING CIRCUIT

WIRING DIAGRAM

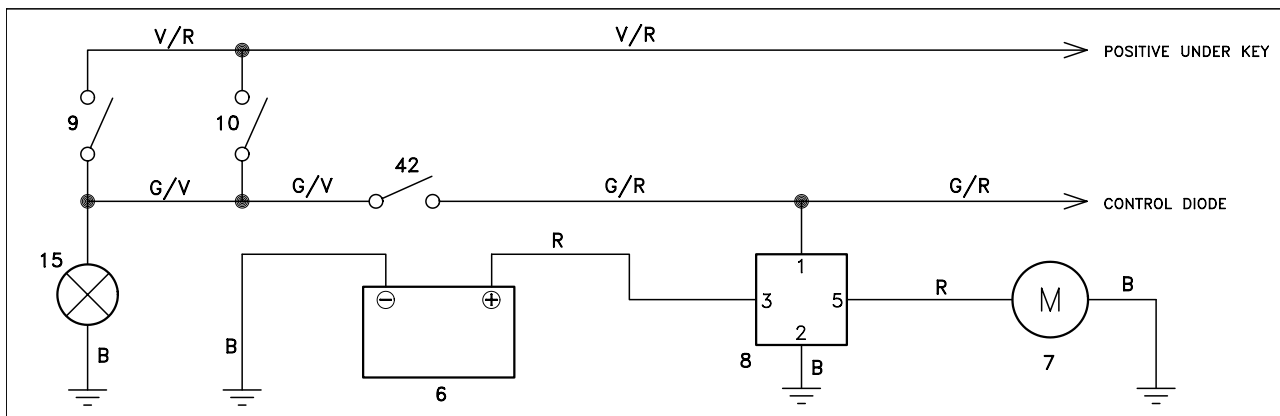

Arrangement of the components:
see p. 84 - 85.

- 6) Battery
- 7) Starter
- 8) Start relay
- 9) Front stoplight switch
- 10) Rear stoplight switch
- 15) Rear light
- 42) Starter button

TECHNICAL DATA

Starter	12 V - 150 W
Brush wear limit	0.9 mm
Start relay.....	12 V - 70 A
Battery.....	12 V - 4 Ah

CAUTION

For safety reasons, to start the engine it is necessary to press the “” push button and to keep one of the brake levers pulled at the same time.

TROUBLESHOOTING

A. STARTER DOESN'T RUN OR RUNS VERY SLOWLY

- Check the battery (p. 87).
- Check the cable connections.
- Check the starter relay (p. 88).
- Check the starter button “” (p. 88).
- Check the stoplight circuit (p. 91).

B. STARTER RUNS, BUT DOESN'T TURN ENGINE OVER

- Check the free wheel of the starter and the gears.

C. STARTER RUNS EVEN IF STARTER SWITCH HAS NOT BEEN DEPRESSED

- Check the cable connections.
- Check the starter relay (p. 88).
- Check the control diode (p. 89).

TEST DATA

STARTER RELAY

- Disconnect all the relay cables.
- Using an ohmmeter tester measure the continuity between terminals 3 and 5.

Exact value: infinite resistance.

- Feed the terminals 1 and 2 with a 12V battery.
- Using an ohmmeter tester measure the continuity between terminals 3 and 5.

Exact value: 0 Ω

STARTER

- Using of an a.c. 0 ÷ 100 A amperometer, check the power absorbed by the starter, after removing the spark plug cap to prevent the engine from starting.
Normal values: 20 A at pickup, 18 A at steady running $\pm 15\%$.
- Using of an ohmmeter-tester, check the resistance between the positive and negative terminals of the starter.
Normal value: 0.5 $\Omega \pm 10\%$.

STARTER BUTTON “”

- Disconnect the starter button connector. Using of an ohmmeter-tester, check the continuity among the contacts in the “pressed” and “released” positions, according to the connections, see p. 82 (B - WIRING DIAGRAM).

G - SENSOR CIRCUIT

WIRING DIAGRAM

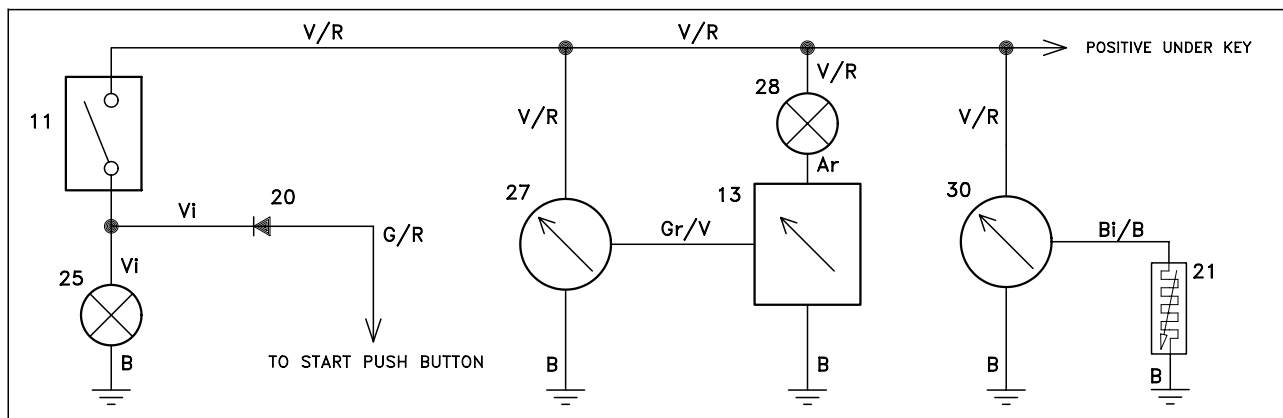

Arrangement of the components:
see p. 84 - 85.

- 11) 2 stroke oil reserve switch
- 13) Fuel level sensor
- 20) Control diode
- 25) 2 stroke oil reserve warning light
- 27) Fuel level instrument
- 28) Low fuel warning light

TECHNICAL DATA

“All-glass” warning
light bulb 12 V - 2W, W2x4.6 d

2 STROKE OIL RESERVE WARNING LIGHT

The 2 stroke oil reserve warning light comes on every time the engine is started, to make sure that the bulb functions correctly.

TROUBLESHOOTING

A. WARNING LIGHT DOESN'T COME ON WHEN OIL LEVEL IS INSUFFICIENT

- Check the bulb.
- Make sure that there is voltage on the green/red cable of the oil level sensor.
- Check the cable connections.
- Check the oil level sensor (p. 89).

B. WARNING LIGHT REMAINS ON EVEN IF OIL LEVEL IS SUFFICIENT

- Check the cable connections.
- Check the oil level sensor (p. 89).

CONTROL DATA

CHECKING THE OIL LEVEL SENSOR

- Disconnect the cables which connect it to the system and remove it from the tank.
- Use an ohmmeter-tester and connect the sensor cables.
- In vertical position, normal value: 0 Ω.
- In reverse position, normal value: infinite resistance.

CONTROL DIODE

- Disconnect it from the system.
- Use a diode tester and connect it as indicated in the figure.

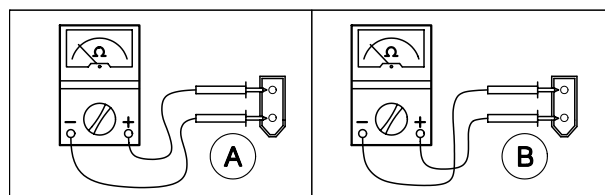

Correct value (measure A): 0 ÷ 1

Correct value (measure B): ∞

If the tester does not include the diode test function, use a 12V battery and a 12V - 2W bulb, connecting the diode as indicated in the figure.

CAUTION

Do not use bulbs over 2W, since the diode may be damaged.

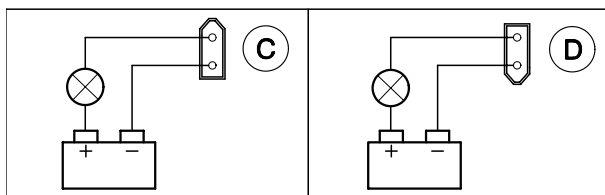

Test (C): the bulb does not light up.

Test (D): the bulb lights up.

FUEL LEVEL INDICATOR

TROUBLESHOOTING

A. INSTRUMENT ALWAYS INDICATES 0 EVEN WITH FULL TANK

- Make sure that there is voltage between the green/red and the blue cable of the instrument.
- Check the cable connections.
- Make sure that the gray/green cable isn't open between the instrument and the sensor.
- Check the instrument (p. 90).
- Check the sensor (p. 90).

B. INSTRUMENT ALWAYS INDICATES "FULL" EVEN WITH EMPTY TANK

- Make sure that the gray/green cable is not grounded.
- Check the instrument (p. 90).
- Check the sensor (p. 90).

C. RESERVE WARNING LIGHT OFF EVEN WITH LESS THAN 1 LITRE FUEL IN THE TANK

- Check the bulb.
- Make sure that there is voltage on the green/red cable of the bulb socket.
- Check the cable connections.
- Check the sensor (p. 90).

D. RESERVE WARNING LIGHT ALWAYS ON EVEN WITH FULL TANK

- Make sure that the orange cable is not grounded.
- Check the sensor (p. 90).

TEST DATA

INSTRUMENT

- Disconnect the three-way connector of the sensor.
- Connect a $5\Omega \pm 10\%$ - 2 W resistance between the gray/green and the blue cable on the main system side.
- If the battery has $13\text{ V} \pm 0.5$ volts, the instrument should read "4/4".
- Connect a 100Ω - 2 W resistance between the gray/green and the blue cable on the main system side.
- If the battery has $13.5\text{ V} \pm 0.5$ volts, the instrument should read "0".

SENSOR

- Make sure that on the three-way connector the entering and exiting cables have the same colours.
- Remove the sensor from the tank.
- Disconnect the three-way connector of the sensor and carry out the following measurements on the sensor side.
- Using an ohmmeter tester measure the following resistances:
 - With gauge in vertical position:
 - between gray/green and blue cable, correct value $\geq 80\ \Omega$.
 - between orange and blue cable, correct value $0\ \Omega$.
 - With gauge overturned in vertical position:
 - between gray/green and blue cable, correct value $10\ \Omega$.
 - between orange and blue cable, correct value $\infty\ \Omega$.

H - DIRECTION INDICATOR CIRCUIT

WIRING DIAGRAM

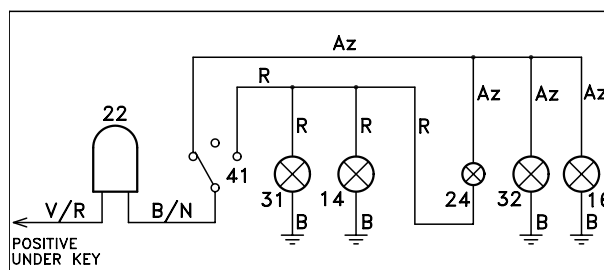

Arrangement of the components:
see p. 84 -85.

- 14) Rear right direction indicator.
- 16) Rear left direction indicator.
- 22) Blinking.
- 24) Direction indicator warning light.
- 31) Front right direction indicator.
- 32) Front left direction indicator.
- 41) Direction indicator switch.

TECHNICAL DATA

Direction indicator bulbs	12V - 10W B.A. 15 S
Blinking	12 V - 2W
Direction indicator warning light bulb-"all-glass"	12V-2W - W2x4.6 d

TROUBLESHOOTING

A. DIRECTION INDICATORS DON'T WORK

- Check the bulbs.
- Check the cable connections.
- Check the direction indicator switch.
- Check the main power supply circuit.
- Replace the flasher.

B. DIRECTION INDICATORS DON'T FLASH, BUT ARE ALWAYS ON

- Check the technical data of the bulbs.
- Check the battery (p. 87).
- Replace the flasher.

TEST DATA

- DIRECTION INDICATOR SWITCH
 - Check the bulb efficiency.
 - Disconnect the switch connector.
- Using an ohmmeter tester, check the continuity among the cables in the various positions, according to the connections, see p. 82 (B - WIRING DIAGRAM).

I - HORN CIRCUIT

WIRING DIAGRAM

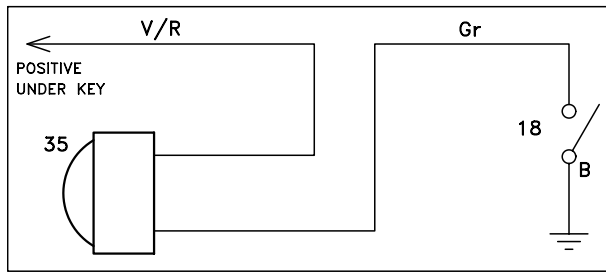

Arrangement of the components:
see p. 84 - 85.
18) Horn push button.
35) Horn.

TECHNICAL DATA

Horn 12 V d.c.

TROUBLESHOOTING

A. HORN DOES NOT SOUND OR IS IRREGULAR

- Check the battery (p. 87).
- Check the cable connections.
- Check the horn push button (p. 91).
- Check the horn (p. 91).

B. HORN KEEPS SOUNDING

- Check the cable connections.
- Check the horn push button (p. 91).

TEST DATA

HORN

- Disconnect the horn and power it directly with a 12 V battery.
- If necessary, adjust the horn adjuster in and out until a satisfactory note is obtained.

HORN PUSH BUTTON

- Disconnect the push button connector.
- Using an ohmmeter tester, check the continuity between the contacts in the "pressed" and "released" positions, see p. 82 (B - WIRING DIAGRAM).

J - STOPLIGHT CIRCUIT

WIRING DIAGRAM

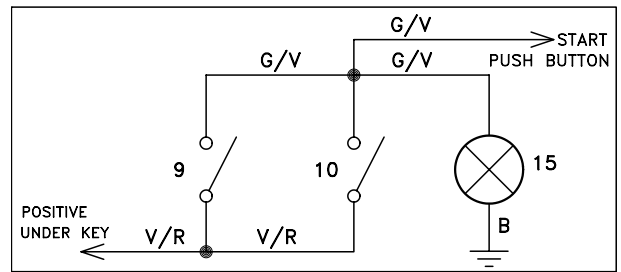

Arrangement of the components:
see p. 84 - 85.
9) Front stoplight switch.
10) Rear stoplight switch.
15) Rear light (rear stoplight bulb)

TECHNICAL DATA

Rear stoplight bulb 12 V - 10 W - BA 15S

TROUBLESHOOTING

A. STOPLIGHT ALWAYS ON

- Check the rear light connections.
- Check the front STOPLIGHT switch (p. 91).
- Check the rear STOPLIGHT switch (p. 91).

B. STOPLIGHT DOESN'T COME ON

- Check the bulb and the bulb socket.
- Check the cable connections.
- Check the general power supply circuit.
- Check the front STOPLIGHT switch (p. 91).
- Check the rear STOPLIGHT switch (p. 91).

TEST DATA

FRONT AND REAR STOPLIGHT SWITCH

- Disconnect the switch cables.
- Put on the brake and, using an ohmmeter-tester, check the resistance between the two cables on the connector:
Normal value with pulled brake: 0 Ω.
Normal value with released brake: infinite resistance.

K - LIGHTING CIRCUIT

LIGHTING CIRCUIT (air-cooled and liquid-cooled version)

WIRING DIAGRAM

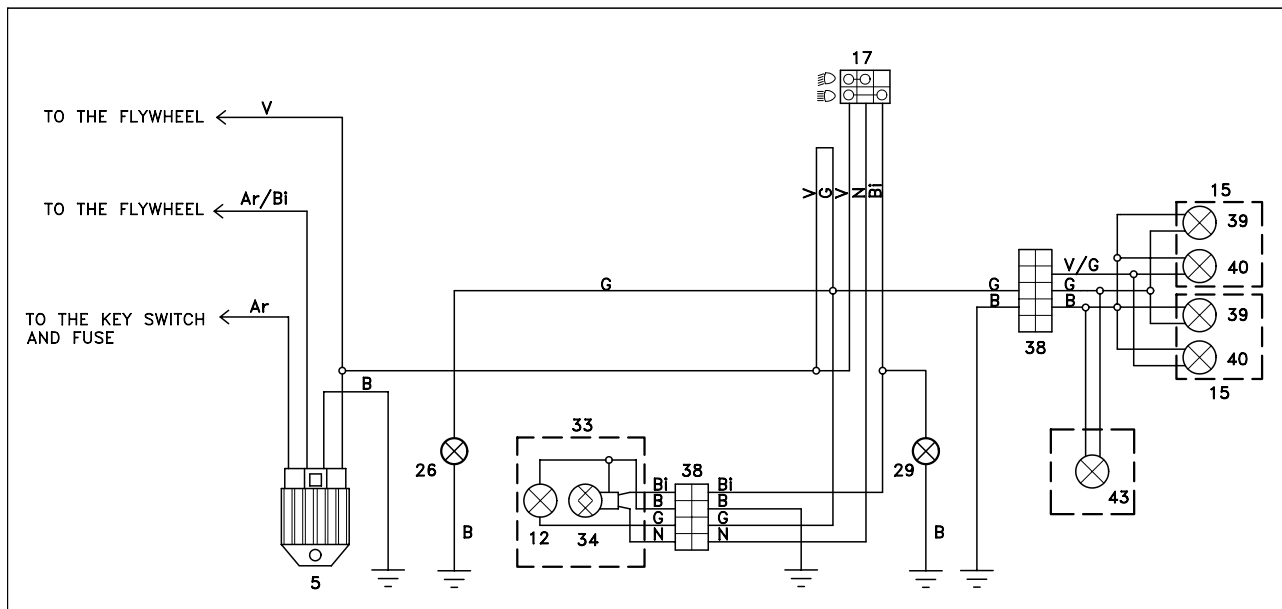

Arrangement of the components:
see p. 84 - 85.

- 5) Voltage regulator.
- 12) Front parking light bulb.
- 15) Rear light..
- 17) Dimmer switch .
- 26) Dashboard light.
- 29) High beam warning light.
- 33) Front parking light.
- 34) Low/high beam bulb.
- 38) Multiple connectors.
- 39) Rear parking light.
- 40) Rear stoplight.
- 43) License plate light.

TECHNICAL DATA

Low beam / high beam light bulb	12V - 35/35 W
Rear parking light bulb	12V - 5W - W 2.1 x 9.5 d
License plate light bulb	12V - 3W - W 2.1 x 9.5 d
Dashboard bulbs.....	12V-1.2 W - W2x4.6 d
	12V-2W W2x4.6 d
	all-glass
High beam warning light bulb	12V-2W W2x4.6 d
	all-glass
Front parking light bulb	12V-3W W2.1x9.5 d
	all-glass

TROUBLESHOOTING

A. ONE BULB DOESN'T WORK

- Check the bulb.
- Make sure that there is voltage on the bulb socket terminals.
- Check the harness connections.

B. NO BULB WORKS

- Check the light switch.
- Check the voltage regulator (p. 92).
- Check the generator (p. 87).

C. BULBS CUT OUT FREQUENTLY

- Make sure that the lights do not vibrate excessively and do not get in contact with the parts of the vehicle which aren't elastically supported.
- Check the cable connections.
- Check the voltage regulator (p. 92).

TEST DATA

VOLTAGE REGULATOR

Change the voltage regulator with a new one.

L - COOLANT TEMPERATURE INDICATOR CIRCUIT

WIRING DIAGRAM

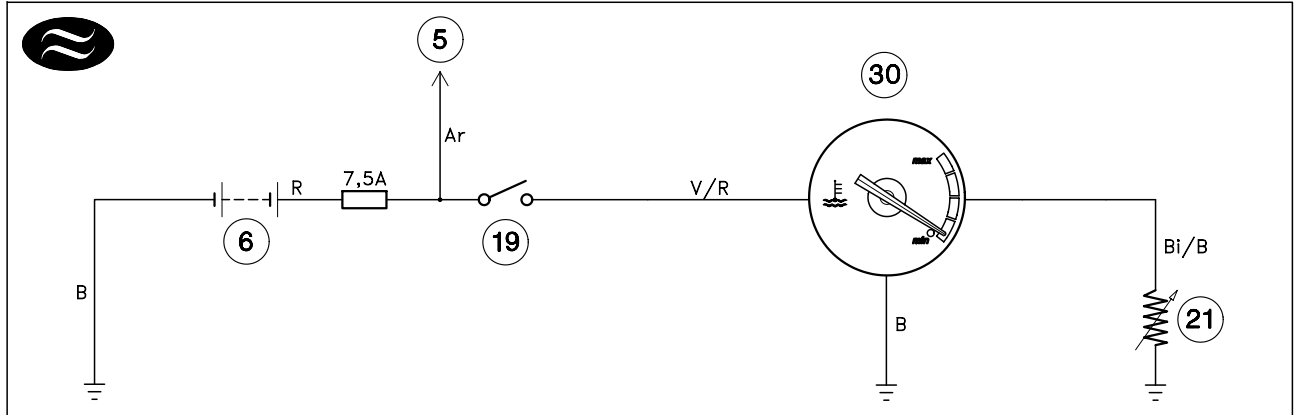

Arrangement of the components: see p. 84 -85.

- 6) Battery
- 5) To voltage regulator
- 21) Coolant thermistor
- 30) Coolant temperature instrument
- 19) Ignition switch / steering lock
- A) Temperature indicator pointer
- B) Terminal
- C) Resistance

TROUBLESHOOTING

⚠ WARNING

Keep fuel and other flammable substances away from the electric components.
Wear a face mask, protective gloves and non-flammable clothes.

A. TEMPERATURE INDICATED TOO LOW

- Check the connections.
- Make sure that the green/red cable of the instrument is powered.
- Check the coolant thermistor (p. 94).
- Check the coolant temperature instrument (p. 93).

B. TEMPERATURE INDICATED TOO HIGH

- Check the cooling circuit.
- Check the connections.
- Check the coolant thermistor (p. 94).
- Check the coolant temperature instrument (p. 93).

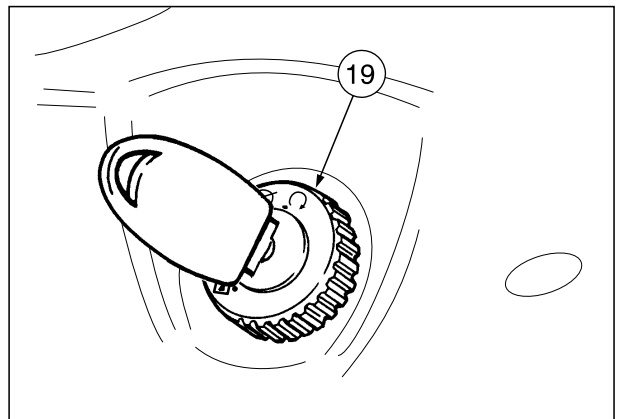
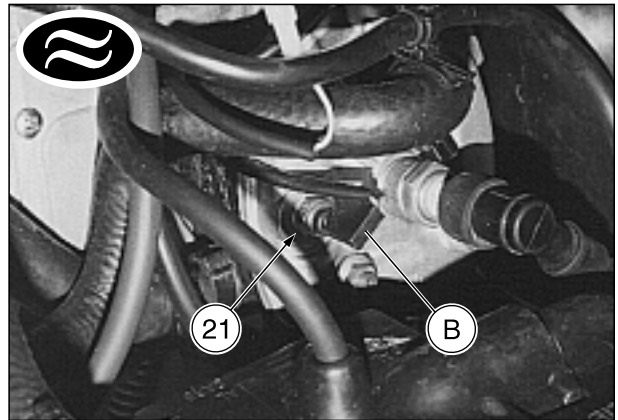

TEST DATA

CHECKING THE COOLANT TEMPERATURE INDICATOR OPERATION

- ◆ Remove the right inspection cover, see p. 20 (REMOVING THE RIGHT AND LEFT INSPECTION COVERS).
- ◆ Disconnect the terminal (B) (white/blue (Bi/B) cable) from the thermistor (21).
- ◆ Connect a 25Ω resistance (C) to the terminal (B).
- ◆ Turn the ignition switch (19) to position "O" (ON).
- ◆ Make sure that the pointer (A) is positioned at the beginning of the red area ("Max") with a tolerance of ± 5°.

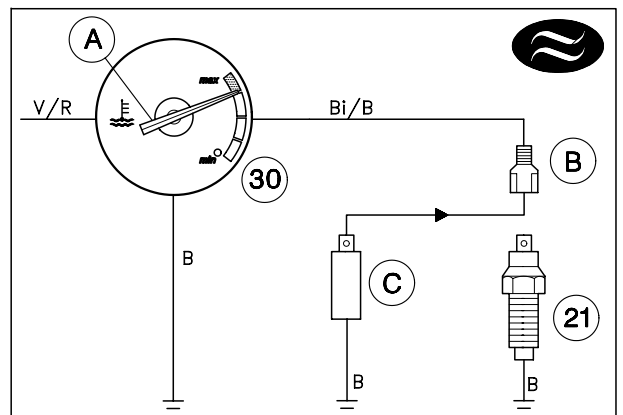

CHECKING THE THERMISTOR OPERATION

WARNING

Keep fuel and other flammable substances away from the electric components.

Wear a face mask, protective gloves and non-flammable clothes.

- ◆ Drain the cooling system, see p. 37 (DRAINING THE COOLANT SYSTEM ).
 - ◆ Remove the left inspection cover, see p. 20 (REMOVING THE RIGHT AND LEFT INSPECTION COVERS).
 - ◆ Disconnect the terminal (B) (white/blue (Bi/B) cable) from the thermistor (21).
 - ◆ Remove the thermistor (21), see ENGINE SERVICE AND REPAIR MANUAL # 921 (I-UK-F-D-E).
 - ◆ Connect a pocket tester (D) (set as an ohmmeter) to the thermistor (21), as indicated in the figure.
 - ◆ Dip the thermistor into a container (F) containing coolant.
 - ◆ Dip a thermometer (E) with range 0÷150 °C into the same container.
 - ◆ Put the container on a burner (G) and slowly warm up the coolant.
 - ◆ Check the temperature indicated by the thermometer and the thermistor value indicated by the tester.
- Make sure that the thermistor varies according to the temperature. as indicated.

Coolant temperature (°C)	Standard values (Ω)
50	about 226 ± 50
115	about 26 ± 10

NOTE If the values do not vary, or if they depart excessively from those indicated in the table, replace the thermistor.

